



# **Superelastic Ball Bearings: Materials and Design to Avoid Mounting and Dismounting Brinell Damage in an Inaccessible Press-fit Application-Part I Design Approach**

Dr. Christopher DellaCorte  
and

Dr. S. Adam Howard  
NASA, Glenn Research Center  
Cleveland, Ohio

*(April 29<sup>th</sup>, 2015)*

*ASTM Rolling Element Bearing Symposium*

*Anaheim, CA*



# Bearing Material: State-of-Art (SOA)

(Current suite of candidates is severely limited)

- **Four general types of bearing materials:**
  - Steels (Corrosion resistant steels, martensitic, austenitic)
  - Ceramics ( $\text{Si}_3\text{N}_4$  balls + steel races, a.k.a., hybrid bearings)
  - Superalloys (e.g., jet turbine blade alloys)
  - Non-ferrous alloys (bronze, nylon etc.)
- **Each of these has inherent shortcomings:**
  - Hard steels are prone to rusting (even “stainless steels” like 440C)
  - Superalloys and austenitic stainless steels (304ss) are soft.
  - Ceramics have thermal expansion mismatch and dent steel races
  - Non-Ferrous materials are weak and lack temperature capabilities
- **No known bearing material blends all the desired attributes:**
  - High hardness, corrosion immunity, toughness, surface finish, electrical conductivity, non-magnetic, manufacturability, etc.



# Superelastic Bearings: NiTi based intermetallics

(Hard but resilient material related to shape memory alloys)

- **60NiTi Basics: market name NiTiNOL 60**
  - W.J. Buehler invented NiTiNOL in the 1950's. Acronym for Ni-Ti-Naval-Ordnance-Laboratory.
  - 60NiTi (60 wt% Ni) is the baseline composition. Alloying with Hf, Zr, and Ta improves microstructure and processing.
  - 60NiTi is not a metal or a ceramic: a weakly ordered inter-metallic compound.
  - Closely related to the shape memory alloys, like NiTiNOL 55, but dimensionally stable.
  - 60NiTi is bearing hard (Rockwell C60) but only half as stiff as steel.
  - Brinell damage threshold load (pounds, kg<sub>f</sub>) is significantly (3-5X) higher than steel.



Highly polished 60NiTi bearing balls

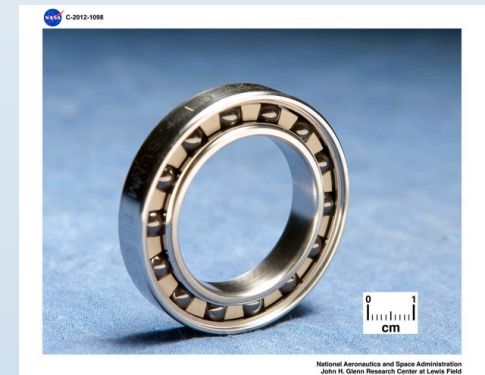

60NiTi-Si<sub>3</sub>N<sub>4</sub> Hybrid Bearing



# Technical Properties Comparison:

Property	60NiTi	440C	Si <sub>3</sub> N <sub>4</sub>	M-50
Density	6.7 g/cc	7.7 g/cc	3.2 g/cc	8.0 g/cc
Hardness	56 to 62 HRC	58 to 62 HRC	1300 to 1500 Hv	60 to 65 HRC
Thermal conductivity W/m-°K	~9 to 14	24	33	~36
Thermal expansion	~11.2×10 <sup>-6</sup> /°C	10×10 <sup>-6</sup> /°C	2.6×10 <sup>-6</sup> /°C	~11×10 <sup>-6</sup> /°C
Magnetic	Non	Magnetic	Non	Magnetic
Corrosion resistance	Excellent (Aqueous and acidic)	Marginal	Excellent	Poor
Tensile/(Flexural strength)	~1000(1500) MPa	1900 MPa	(600 to 1200) MPa	2500 MPa
Young's Modulus	~95 GPa	200 GPa	310 GPa	210 GPa
Poisson's ratio	~0.34	0.3	0.27	0.30
Fracture toughness	~20 MPa/√m	22 MPa/√m	5 to 7 MPa/√m	20 to 23 MPa/√m
Maximum use temp	~400 °C	~400 °C	~1100 °C	~400 °C
Electrical resistivity	~1.04×10 <sup>-6</sup> Ω-m	~0.60×10 <sup>-6</sup> Ω-m	Insulator	~0.18×10 <sup>-6</sup> Ω-m

- ***Modulus is ½ that of steel, yet hardness is comparable.***
- ***Tensile strength akin to ceramics.***
- ***Does not rust. Enhanced static load capacity.***



# 60NiTi: Stress-Strain Behavior

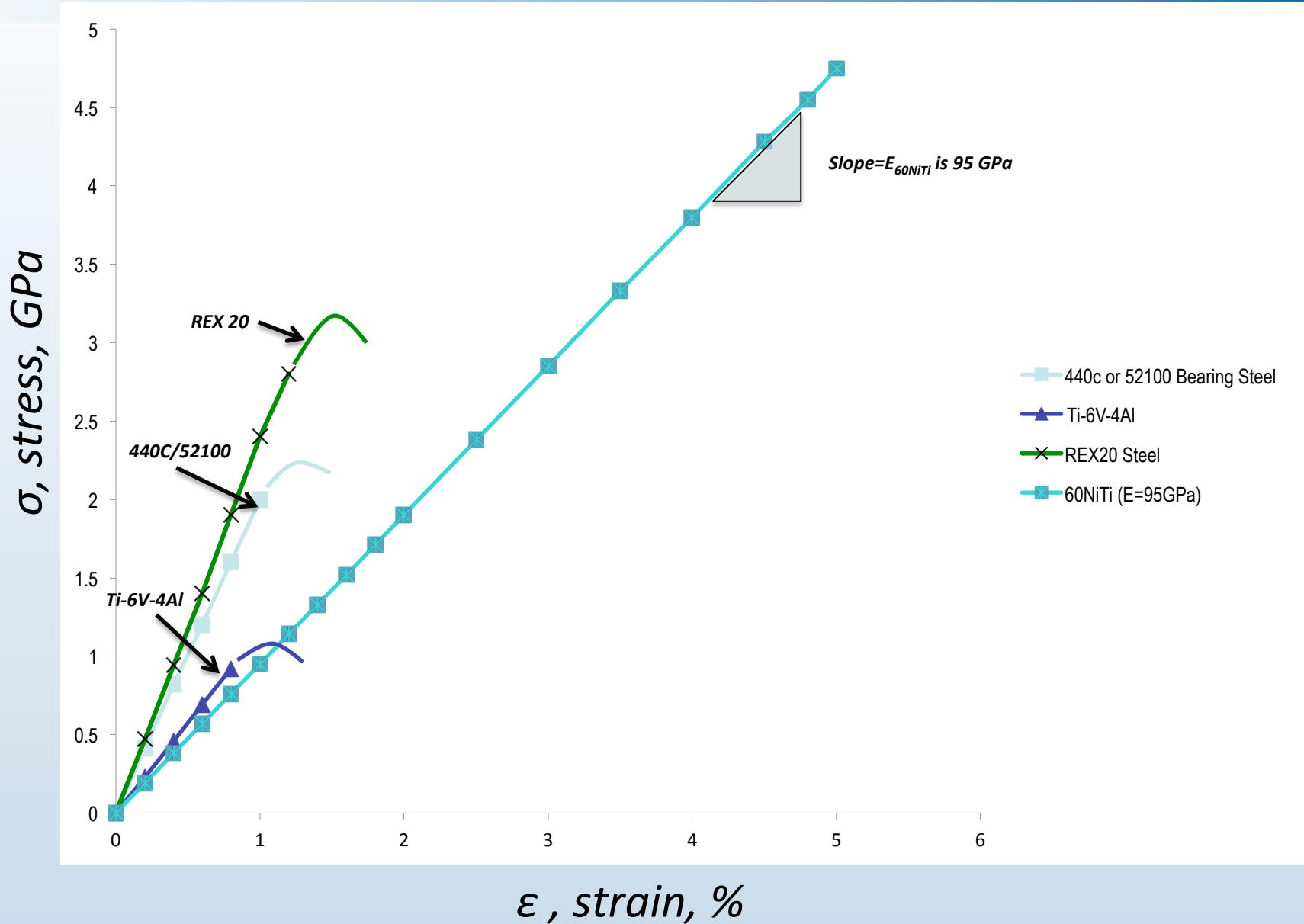



# Contact Engineering: Ball-Race

- **When hard surfaces contact**
  - Forces are transmitted at small, concentrated contact points (Hertz).
  - Resulting stresses cause deformations that help “spread the load”.
  - Contact area is a function of the geometry, material stiffness and load.
  - High stiffness (modulus) inhibits deformations leading to small contact area and high stresses (contrast with a tire contacting the ground).

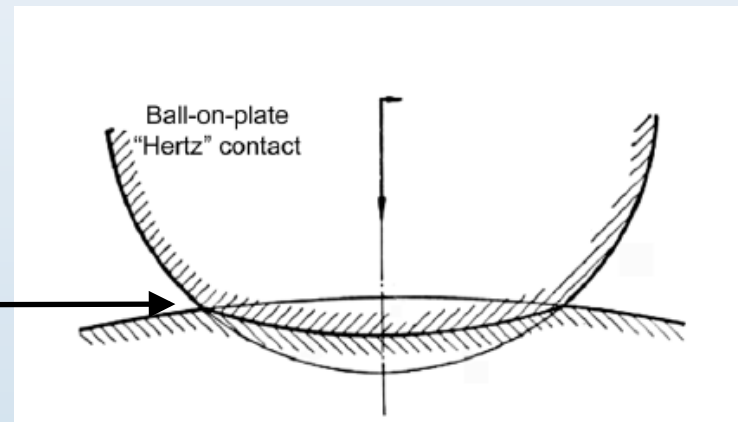
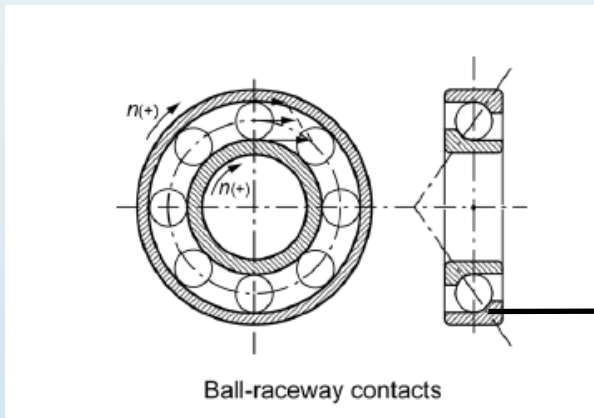

- ***Hard surfaces can dent***
  - *Even modest loads can exceed stress capability limits.*
  - *Bearing raceways are particularly prone to Brinell dent damage.*



# Dent Depth vs. Hertz Contact Stress (12.7 mm diameter $\text{Si}_3\text{N}_4$ ball against 60NiTi plate)

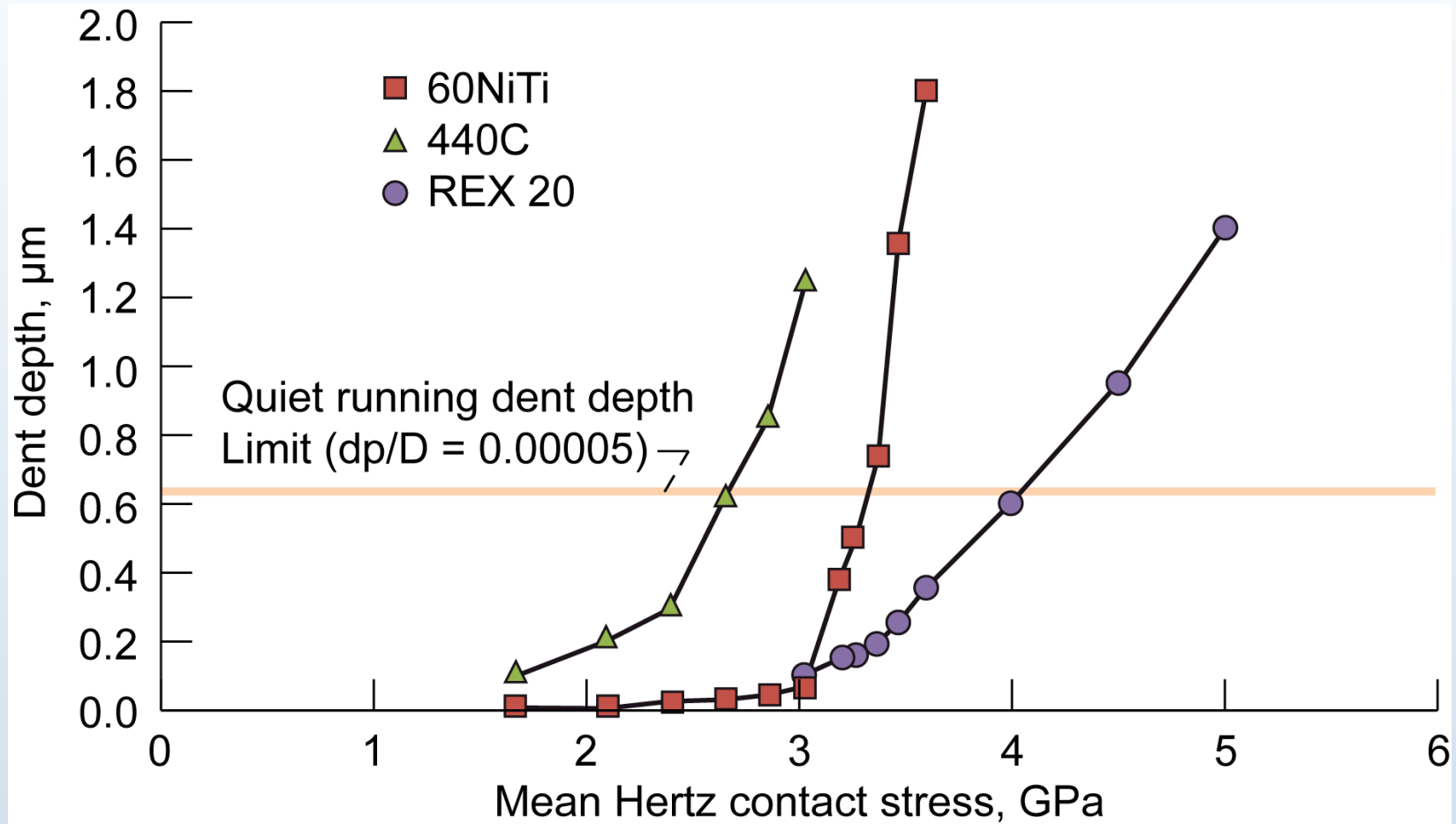

Limit load stress for indentation damage for 60NiTi falls between conventional bearing steels (440C) and high performance tool steels (REX 20).



# Dent Depth vs. Load

( $\text{Si}_3\text{N}_4$  ceramic ball pressed against 60NiTi plate)

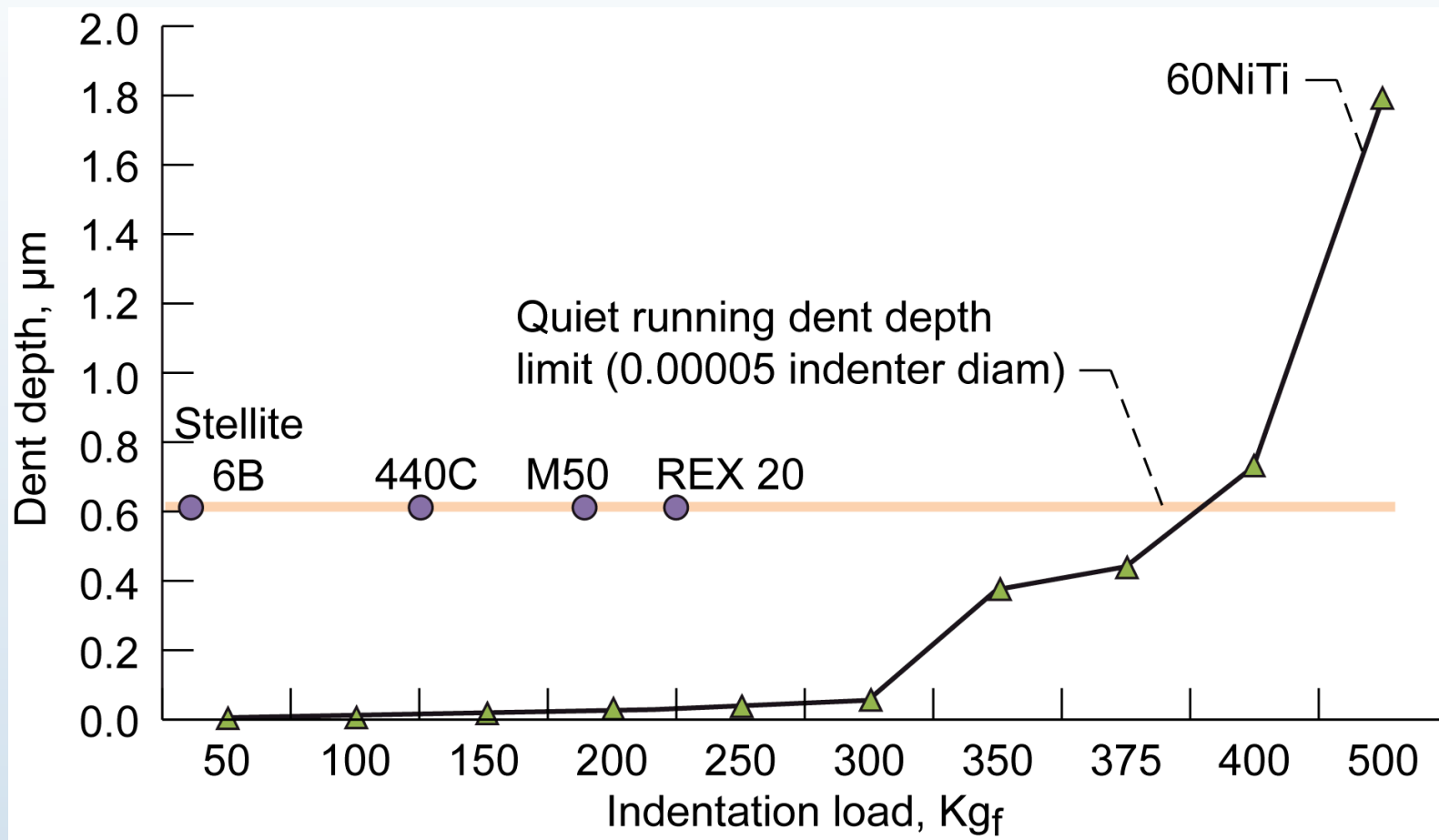

**60NiTi combines high hardness, reduced stiffness and superelasticity to increase load capacity over other steels dramatically. Immunity to rust is an added bonus.**





# Brinell Dent Behavior: Varying Ball Sizes

*Dent Depth vs. Stress: 6.4 to 12.7mm Si<sub>3</sub>N<sub>4</sub> indenter balls*

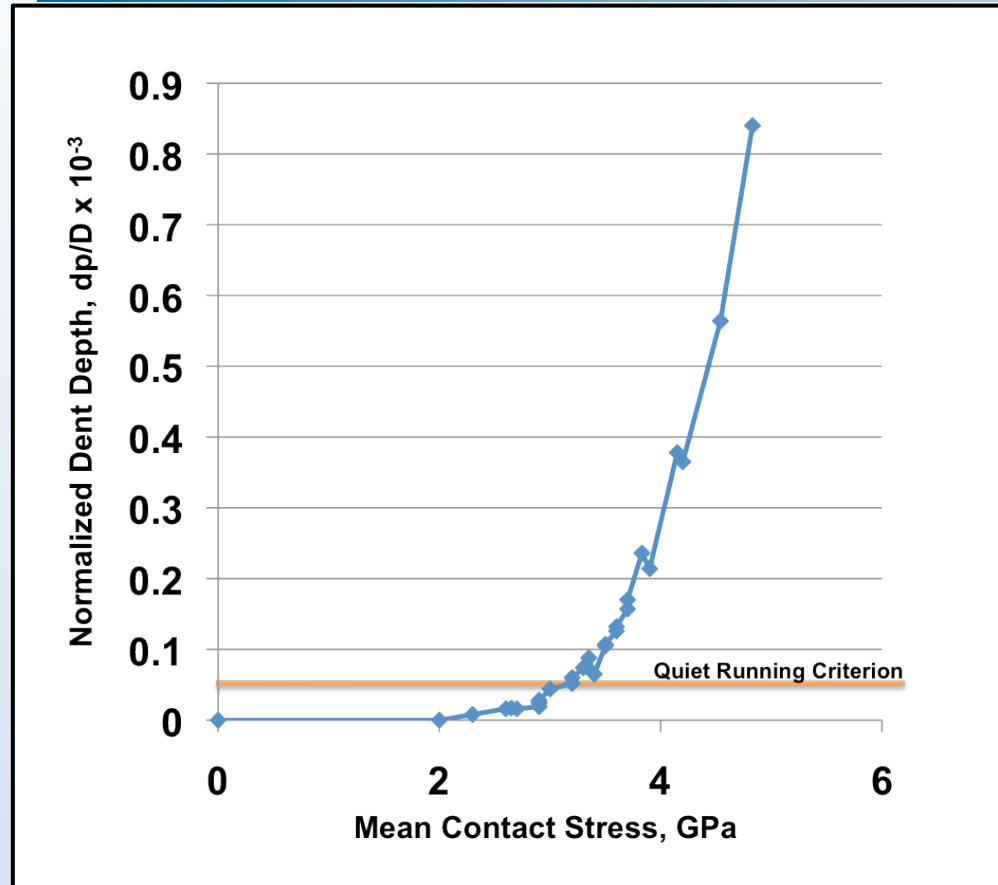

- **Implications**

- *Hertz stress limit for quiet running (~3.0 GPa) is average among bearing steels.*
- *Low modulus + High Elasticity Range + High Hardness = High Load Capability.*



# Dent Depth vs. Stress: On bearing races?

Full scale (50mm bore) bearing inner race. Dented with 8.74mm  $\text{Si}_3\text{N}_4$  ball.

50mm bore 60NiTi-Hybrid Bearing specimens

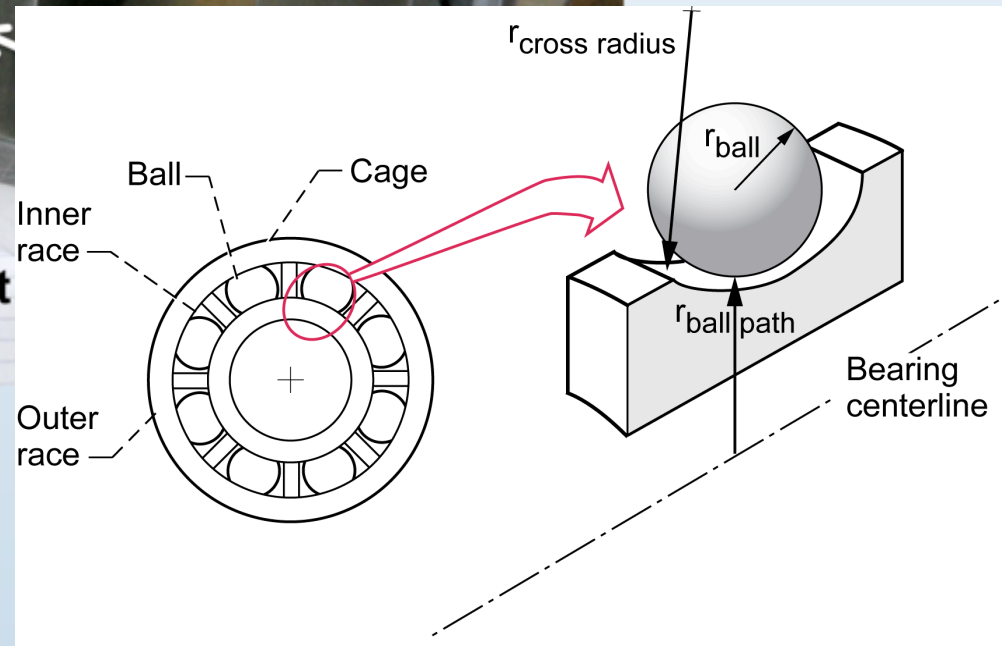
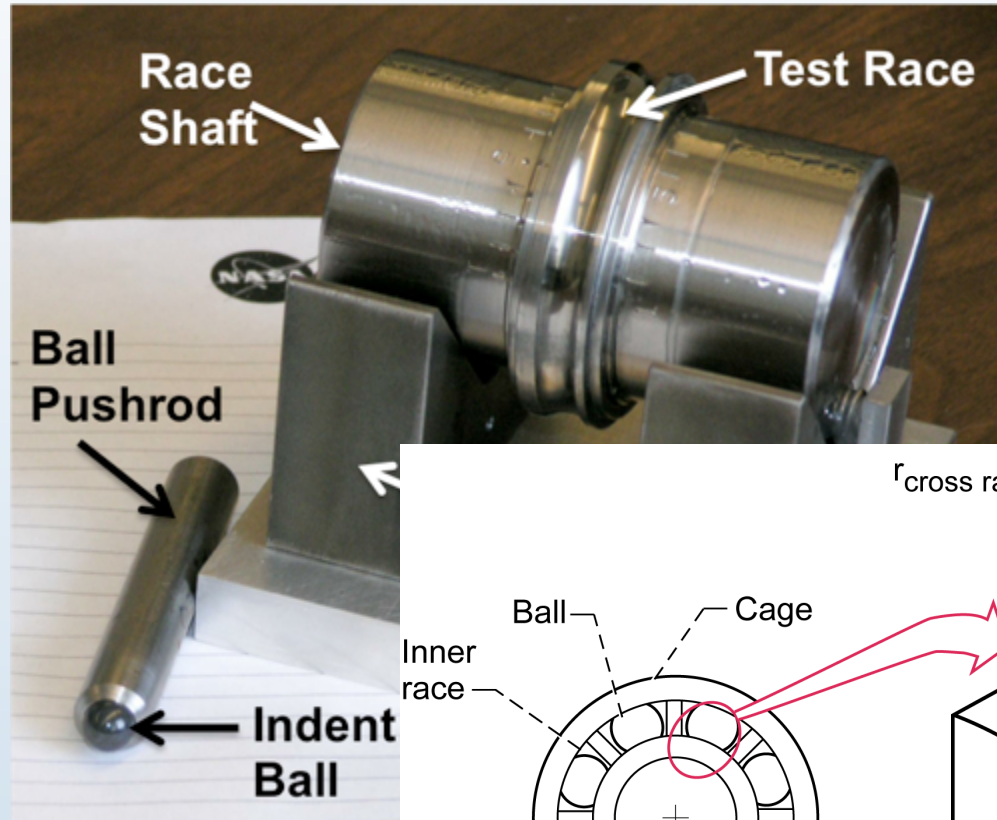



# Dent Depth vs. Stress: Data Plot

## *Normalized Dent Depth Versus Mean Hertz Contact Stress*

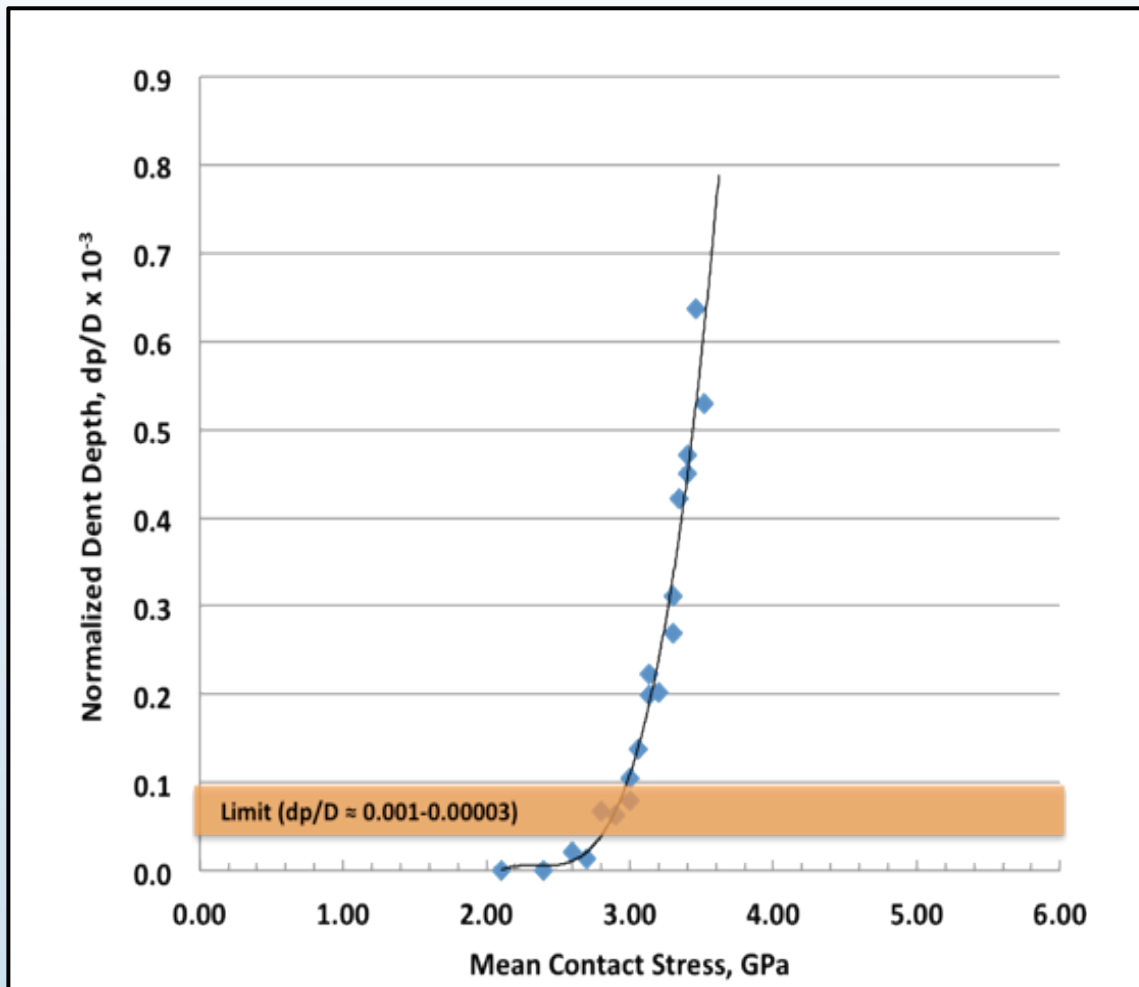

*Exemplary dent resistance applies to real bearing races as well as flat plates.*



# Opportunities: Superelastic Bearings

(ISS Wastewater purifier system offers technology “pull”)

- **Superelastics enabling characteristics:**
  - Impact load tolerance.
  - Intrinsic corrosion resistance (cannot rust)
  - High static load capability.
  - Non-magnetic but electrically conductive
  - Emerging manufacturing (M&P) database.
- **ISS Urine Processor Pathfinder applications:**
  - 50mm bore centrifuge bearings (wet, low speed, low load).
  - Compressor drive gears (dry lubed, damp, low load, high speed).
  - 12.7mm compressor bearings (moderate load, high speed, inaccessible location).

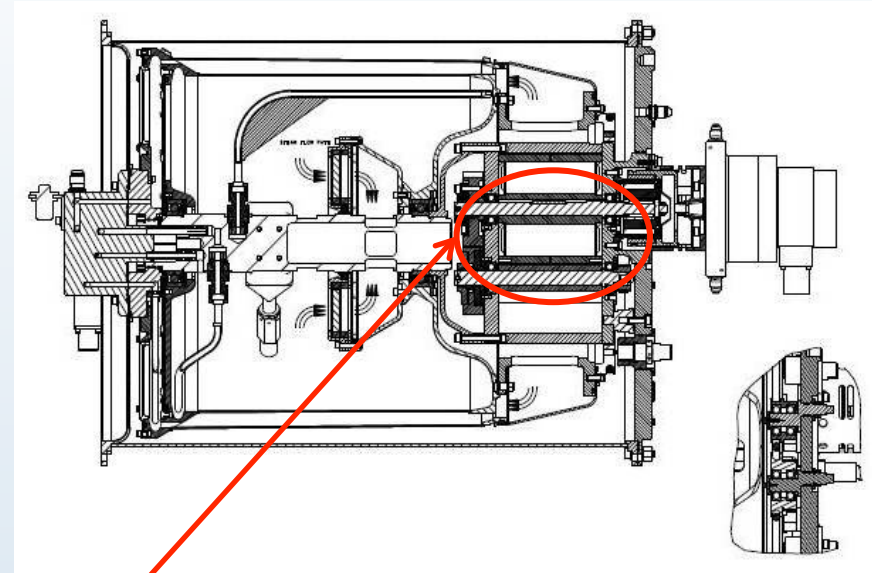

- **Compressor Bearings**
  - *Support roots blower lobes.*
  - *2000 rpm, high precision.*
  - *Moisture exposure.*
  - *Accessible for installation*
  - *Disassembly loads ball-race contact requiring bearing replacement.*



# Bearings 101: Installation Basics

(Source: NTN-SNR Bearing Catalog)

Apply the force on the ring to be installed. This force must not under any circumstances be transmitted through the rolling elements, as this would make dents in the raceways.

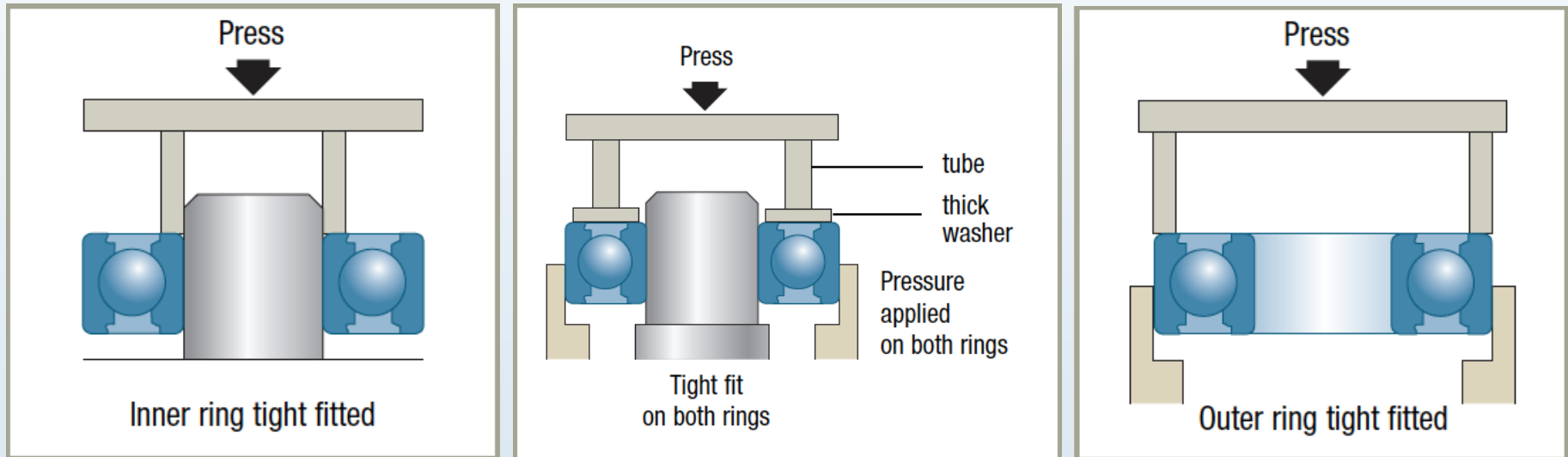

- **Compressor Application**
  - *Installation accomplished by pressing on both rings (center image) against tight fits.*
  - *Disassembly achieved by pulling on housings resulting in scrapped bearings.*
- **ISS Challenge and Opportunity**
  - *Design a bearing impervious to disassembly damage (without altering machine design).*
  - *Nice opportunity to expand NiTi bearing technology to smaller (R8) size.*



# Current Machine Design: Assembly: OK, Removal: Not OK

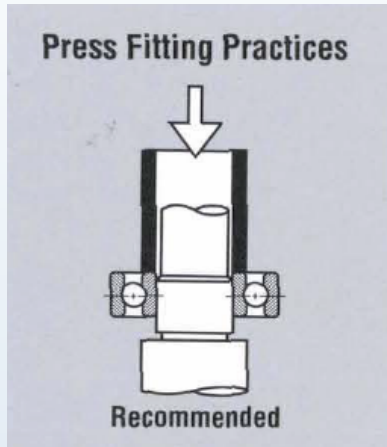

**Acceptable**

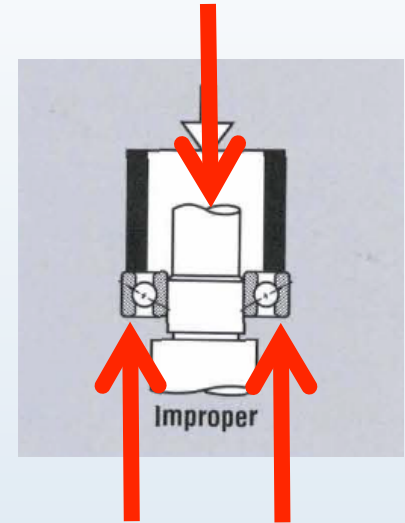
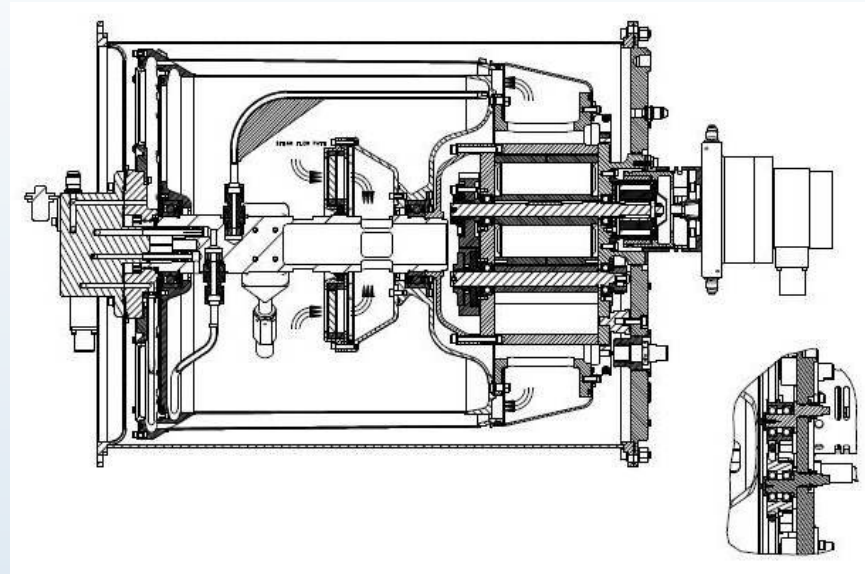

**Unacceptable**

- **Current Bearing: Deep Groove Instrument Design**
  - *Installation accomplished by pressing on both rings against tight fits.*
  - *Disassembly achieved by pulling on housings resulting in scrapped bearings.*





# Design Goal: Blind Disassembly Tolerant Bearing

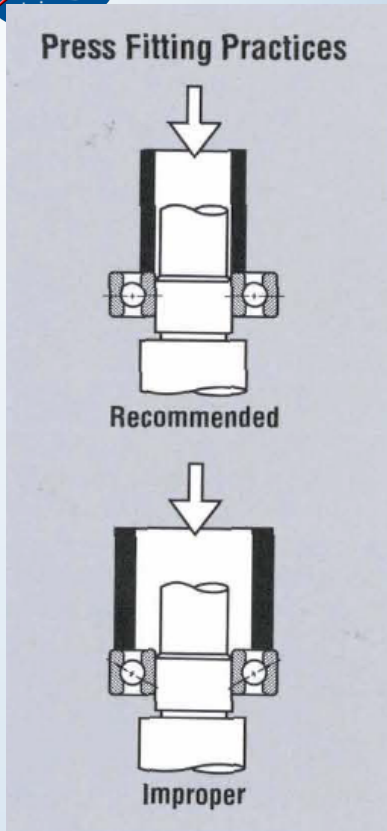

+ **Materials and  
Geometry  
Changes** =

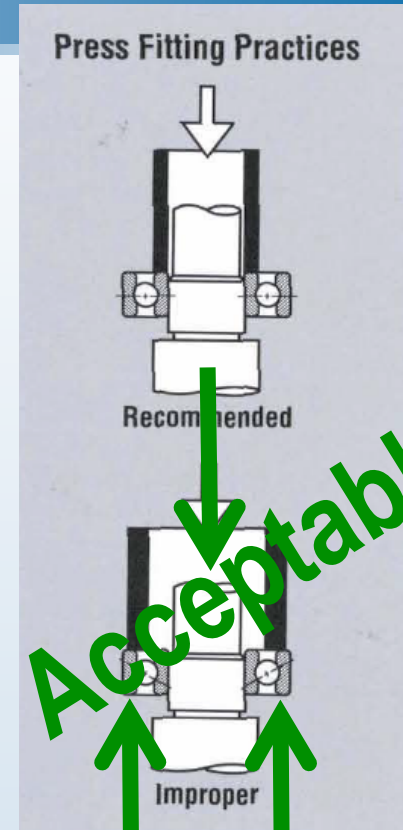

- **Near term:**
  - Reduce machine costs and assembly headaches.
  - Prove fabrication path for small bearings.
  - Verify static axial load capacity.
- **Longer term:.**
  - Expand experience envelope for NiTi bearings.
  - Evaluate new alloys and gather additional design data.



# Design Approach: Reusable NiTi R8 Compressor Bearing

(Leverage geometry and materials)

## • Materials

- 60NiTi has static stress limit of 3.1GPa. ~3x the static load capacity of steel.
- $\text{Si}_3\text{N}_4$  balls match current baseline but reduce load capacity.

## • Operating Conditions

- Moderate speed (2000 rpm), low operating load.
- Moisture exposure, 5000 hour life requirement.
- 1.5-2.2kN installation/removal axial load.

## • Bearing Geometry

- Baseline bearing is deep groove ball bearing with conventional internal geometry.
- Adjust internal design to mimic angular contact bearing for improved axial load capability (w/o race truncation).

60NiTi-Microstructure  
(etched to reveal grains)

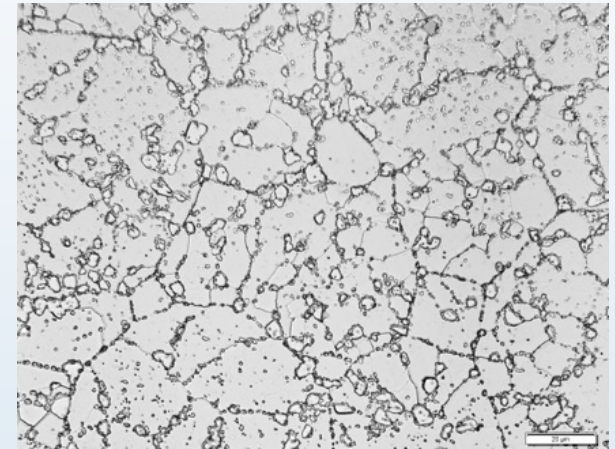

Ball-Race Contact Engineering

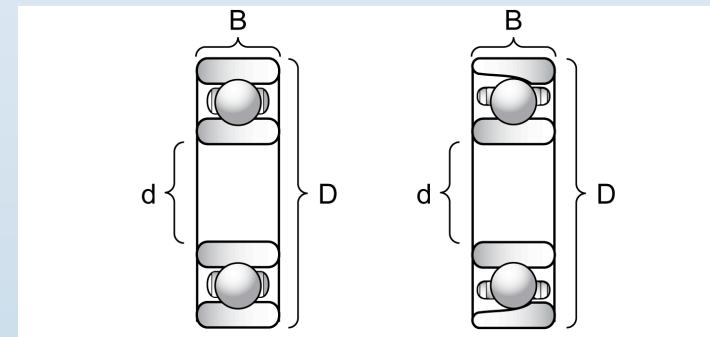





# Design Calculations: Model Single ball-race contact

Property	Value
Outside Diameter, mm (inch)	28.58 (1.125)
Inside Diameter or Bore, mm (inch)	12.70 (0.500)
Width, mm (inch)	3.40 (0.134)
Ball Diameter, mm (inch)	3.969 (0.15625)
Outer Race cross path radius, mm (inch)	2.064 (0.08125)
Outer Race ball path radius, mm (inch)	12.31 (0.4844)
Inner Race cross path radius, mm (inch)	2.064 (0.08125)
Inner Race ball path radius, mm (inch)	8.33 (0.3281)

- **Physical Arrangement**

- **Ball loaded on inner race.**
- **Maximum load to reach damage stress (3.1GPa).**
- **Estimate resulting radial and axial load capacity and compare to catalog values and disassembly requirement.**

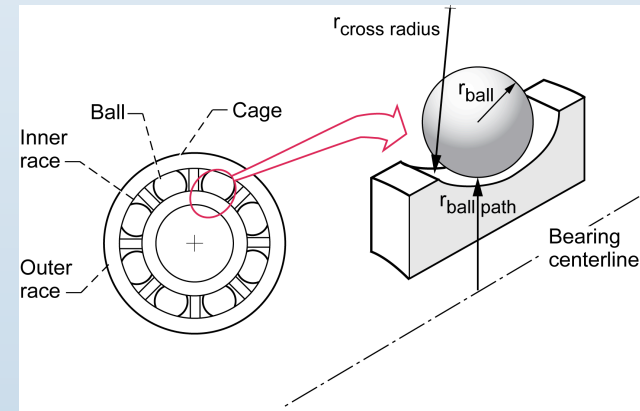



# Single ball and full bearing load capability

Ball/Race Material	Contact Stress Limit, Gpa (ksi)	Single Ball Load Capacity, N (lb)	Bearing Radial Load Capacity, 2 balls, N (lb)	Bearing Axial Load Capacity, 9 balls, N (lb)
440C/440C	2.5 (360)	788 (177)	1576 (354) <sup>+</sup>	7092 (1593)*
Si <sub>3</sub> N <sub>4</sub> /440C	2.5 (360)	579(130)	1158 (260) <sup>+</sup>	5210 (1170)*
Si <sub>3</sub> N <sub>4</sub> /60NiTi	3.1 (450)	2893(650)	5786 (1300)	26037 (5850)*
Si <sub>3</sub> N <sub>4</sub> /REX20	3.8 (550)	1682(378)	3364 (756)	3364 (3402)*

<sup>+</sup>Agrees with catalog value.

\*Exceeds catalog value.

- Data Interpretation

- Hertz stress limit dictates radial load capacity.
- Use of 60NiTi increases radial load capacity.
- Factors other than stress limit (most likely ball-race contact truncation), limits axial load capability.
- More detailed 3-D stress-strain examination needed to close design.



# Summary Remarks: Part I Design Approach

- **NiTi-based materials offer a unique combination of high hardness, low modulus, and extensive elastic deformation range resulting in superior static indentation load capability.**
- **Enhanced static load capability is enabling for bearings used in spacecraft other machinery exposed to shock and vibration.**
- **For the ISS compressor bearing application, the estimated static load capacity based upon contact stress alone exceeds disassembly forces.**
- **More detailed 3-D Finite Element Based analyses are needed to assess whether ball-race overriding occurs during bearing removal.**
- **An experimental test program on 60NiTi R8 ball bearings is currently underway to validate the modeling and analyses presented.**



**Thank You!**