

printout of E-14153 mats

1028716

A POWER CONVERSION CONCEPT FOR THE JUPITER ICY MOONS ORBITER

Lee S. Mason*

National Aeronautics and Space Administration
Glenn Research Center
Cleveland, Ohio 44135

Phone: 216-977-7106, Email: Lee.S.Mason@nasa.gov

ABSTRACT

The Jupiter Icy Moons Orbiter (JIMO) is a bold new mission under development by the Office of Space Science at NASA Headquarters. JIMO is examining the potential of Nuclear Electric Propulsion (NEP) technology to efficiently deliver scientific payloads to three Jovian moons: Callisto, Ganymede, and Europa. A critical element of the NEP vehicle is the reactor power system, consisting of the nuclear reactor, power conversion, heat rejection, and power management and distribution (PMAD). The emphasis of this paper is on the non-nuclear elements of the reactor power system.

The assumed power level for the NEP vehicle was 100 kWe, and a liquid-metal cooled reactor concept was assumed for the study, although both heat-pipe and gas-cooled reactors are possible alternatives. The power conversion system consists of two, independent 100 kWe Brayton cycle converters, providing 100% converter redundancy. The converter design is based on state-of-the-art superalloy hot-end construction permitting turbine inlet temperatures of 1150K and cycle efficiencies in excess of 20%. The only moving part is a single-shaft, radial turbo-compressor which is supported by gas foil bearings. The rotary alternator delivers high voltage, three-phase AC to the PMAD subsystem. The PMAD concept includes two completely redundant modules, each capable of delivering 100 kWe to the spacecraft. Either PMAD module can service the full suite of thruster power processing units, the spacecraft bus, and the power system parasitic loads. The waste heat rejection system includes a pumped liquid-metal heat transport loop and water heat pipe radiator panels. The heat transport loop interfaces with the Brayton gas coolers, allowing either or both Brayton units to utilize the full radiator surface. The radiator consists of two planar wings, each having a series of stair-cased deployable rectangular panels that are contained within the radiation shield half-angle

and provide two-sided heat rejection. This paper discusses some of the key trade-offs considered in arriving at the baseline concept and provides a summary of the power system performance and mass.

INTRODUCTION

The Jupiter Icy Moons Orbiter (JIMO) mission is an element of NASA's Project Prometheus Program. The JIMO mission is studying the potential of Nuclear Electric Propulsion (NEP) to deliver scientific payloads to the Jovian moons of Callisto, Ganymede, and Europa. A NEP vehicle concept was developed, and trade studies were performed, to accomplish JIMO. The power and propulsion module consisted of a 100 kWe reactor power system and a 6800 second specific impulse, ion propulsion system. A general block diagram for the NEP vehicle concept is shown in Figure 1.

The emphasis of this paper is on the non-nuclear elements of the reactor power system including the power conversion, heat rejection, and power management and distribution (PMAD). A liquid-metal (lithium) cooled reactor concept was assumed for the study, although both heat-pipe and gas-cooled reactors are possible alternatives. The reactor includes a truncated conical radiation shield with a 10 degree half angle that attenuates induced radiation levels to 25 krad and 1×10^{11} neutrons/cm² at the payload located 30 meters from the reactor. The reactor also includes a liquid-metal to gas heat exchanger that accommodates the integration of a Closed Brayton Cycle (CBC) power conversion system. The CBC conversion system was selected for the study based on its high efficiency and

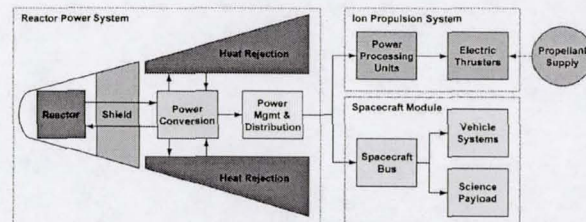

Figure 1. NEP Vehicle Block Diagram

*Research Engineer.

Copyright © 2003 by the American Institute of Aeronautics and Astronautics, Inc. No copyright is asserted in the United States under Title 17, U.S. Code. The U.S. Government has a royalty-free license to exercise all rights under the copyright claimed herein for Governmental purposes. All other rights are reserved by the copyright owner.

suitability for the power level of interest. Stirling and thermoelectric conversion technologies are also under consideration. The heat rejection and PMAD concepts are oriented to CBC power conversion, although aspects of the designs would be applicable to the other conversion options.

TRADE STUDIES

There were many conceptual design trade studies that were conducted related to the power subsystems. System-level studies examined design and off-design operating modes, determined startup requirements, evaluated subsystem redundancy options, and quantified the mass and radiator area of reactor power systems from 20 to 200 kWe. The majority of this activity centered around Brayton cycle analysis and optimization, aimed at defining cycle performance and subsystem interface requirements. In the Brayton converter subsystem, studies were performed to investigate converter packaging options, and assess the induced torque effects on spacecraft dynamics due to rotating machinery. In the heat rejection subsystem (HRS), design trades were conducted on heat transport approaches, material and fluid options, and deployed radiator geometries. In the PMAD subsystem, the overall electrical architecture was defined and trade studies examined distribution approaches, voltage levels, and cabling options.

REACTOR POWER SYSTEM

The power system conceptual design process is iterative and involves technology assessments, systems analysis, subsystem design, and vehicle integration studies. Technology assessments provide a basis for selecting design parameters that are consistent with launch date. Some examples of important design parameters are reactor outlet temperature, radiator panel areal mass (defined as mass per unit area or kg/m^2), and alternator output voltage. These must be selected based on current Technology Readiness Levels (TRL) and realistic projections for technology advancement prior to launch. Systems analysis is conducted using the technology design parameters as inputs to analytical models to arrive at an initial concept. Subsystem design provides further definition and serves to either substantiate or revise the design parameter assumptions. Finally, vehicle integration studies examine the feasibility of the design working within the spacecraft and mission framework. At each stage in the process, new information usually causes the designers to reassess previous assumptions and adjust the overall concept. The sections below describe some of the system-level trades conducted during the study.

Cycle Analysis

The power systems analysis was performed using a Glenn Research Center computer model called

NUCOPT, which accounts for the reactor, power conversion, heat rejection, and PMAD subsystems.¹ The Brayton cycle state point diagram at the conclusion of the study process is shown in Figure 2. The Brayton converter interfaces to the reactor through the heat source heat exchanger (HSHX), to the main radiator through the gas cooler, and to the PMAD through the alternator. An inert gas mixture (HeXe) is used as the Brayton working fluid. The only moving part is a single-shaft, radial turbo-compressor which is supported by gas foil bearings.

The power system design included two independent 100 kWe converters, based on a proposed mission requirement to provide "fail-op" redundancy (defined as continued full power capability after component failure) in the power conversion subsystem. The HSHX gas outlet temperature was set at 1150 K, allowing the use of nickel-based superalloys for the hot-end converter components. Figure 3 reveals an aspect of the cycle optimization process—showing reactor power, radiator area, and power conversion mass sensitivity to compressor inlet temperature. The minimum mass design point occurs at a compressor inlet temperature of 411 K. The cycle analysis assumed component efficiencies of 90% for the turbine, 80% for the compressor, and 92% for the alternator, and the recuperator effectiveness was set at 95%. Bearing and

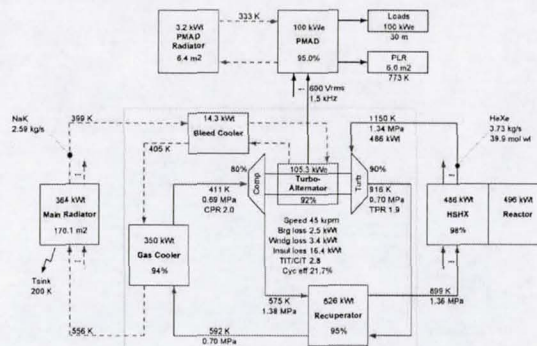

Figure 2. Brayton Cycle Diagram

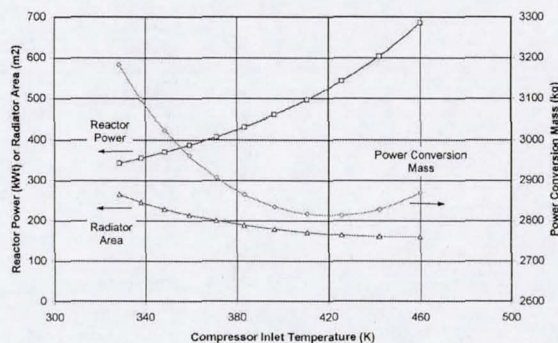

Figure 3. Brayton Cycle Optimization

alternator windage losses were 2.5 and 3.4 kWt, respectively. Insulation losses were estimated at 16.4 kWt. The design point Brayton cycle efficiency was 21.7% and the total end-to-end power system efficiency was 20.2%, resulting in a required reactor thermal power of 496 kWt.

Brayton heat rejection is accomplished with a pumped NaK heat transport loop and a two-sided main radiator having a total surface area of 170 m². The total waste heat load was 364 kWt, comprised of 350 kWt from the gas cooler and 14 kWt from an alternator bleed cooler. The alternator bleed cooler provides waste heat dissipation for bearing, windage, and alternator electromagnetic losses. The radiator area was determined based on an effective sink temperature of 200 K, fin effectiveness of 92%, and surface emissivity of 0.9.

The three-phase alternator produces 105 kWe at 45000 rpm, 600 Vrms line-to-line, and 1.5 kHz. The 95% efficient PMAD system delivers 100 kWe to the loads over a 30 meter transmission distance. The PMAD includes power and control electronics, switchgear, and cabling. Also included is a full power shunt Parasitic Load Radiator (PLR) and a separate PMAD thermal control radiator. The PLR has an effective temperature of 773 K and a surface area of 6 m². The 6.4 m² PMAD radiator maintains an electronics cold-plate temperature at 333 K under a 3.2 kWt heat load.

Operating Modes

Additional cycle analyses were performed to examine off-design operating modes for the Brayton converters. The sizing condition for the Brayton components was based on 100 kWe output, under a "converter-out" condition. Nominally, the two Brayton units would operate at 50% power. This is achieved by operating the units at a lower rotor speed and charge pressure. The lower rotor speed results in an alternator voltage decrease to 400 Vrms line-to-line. The major benefit of operating the units at part power is a reduction in the thermal stresses and bearing loads. However, the reactor thermal power increases to 554 kWt for the nominal operating mode, due to a modest decrease in cycle efficiency. An alternative approach is to operate a single unit and maintain a cold-standby unit.

Another operating mode that was considered was the minimum power coast mode. This mode would be utilized during interplanetary coasting (electric thrusters off) and upon arrival at the Jupiter moon science orbits. The goal was to reduce reactor thermal power and operating temperature to minimize fission product buildup, thermal stress, and material creep. The HSHX gas outlet temperature was set at 950 K. The Brayton unit output power and reactor thermal power was

determined based on the need to maintain the NaK radiator coolant above its freezing temperature of 262 K without re-stowing radiator panels. The resulting cycle analysis, assuming off-design component efficiencies, indicated that the system output power could be reduced to 20 kWe with a corresponding reactor thermal power of 118 kWt. Alternatively, the reactor power system could be operated at full power throughout the mission, and the PLR could be utilized to shunt any excess power not required by the loads.

Startup Power

A representative startup approach was defined for the reactor power system, based on electrical power provided from the spacecraft bus solar arrays and/or batteries. Startup is initiated by energizing the PMAD controller and reactor instrumentation and control (I&C) subsystem. After the reactor is started to 10% thermal power, the first radiator wing is partially deployed and oriented to the sun for heating. The radiator wing is charged with coolant and the pump is started. Then the first Brayton unit is electrically motored (or rotated) to circulate the HeXe working fluid for approximately 15 minutes before a self-sustaining condition is achieved and positive power is being produced. As the reactor power is increased to 50% and full deployment of the first radiator wing is completed, the Brayton unit ramps to nominal operating power. At that point, all of the spacecraft loads would be transferred from the spacecraft bus to the alternator bus. The total time to achieve bus switch-over was estimated at 4 hours, and startup energy for the power system was approximately 1 kW-hr. Deployment of the second radiator wing and startup of the second Brayton unit would be accomplished from the alternator bus.

A hot restart following a Brayton converter shutdown was estimated to require less than 0.2 kW-hr. The large thermal capacitance of the reactor and converter units should permit hot restarts for several hours following an unexpected shutdown, the limiting factor being the freezing of the radiator coolant.

Redundancy Trades

The mass of the Brayton converters, heat rejection, and PMAD for the baseline configuration was estimated at 2818 kg. This mass was based on two 100 kWe Brayton units, two 100 kWe PMAD modules, and a heat rejection subsystem capable of dissipating the waste heat from a single Brayton unit at 100 kWe or two units at 50 kWe each. Alternatives to this configuration were evaluated relative to the full power capacity of the individual subsystems. Table 1 shows the mass differences for several alternative configurations. A single-string architecture would provide a 982 kg mass savings, whereas a configuration with full 100% redundancy in the converters, radiators, and PMAD

would incur a 854 kg mass penalty. Configurations with greater than three Brayton units were not judged practical due to constraints in vehicle packaging and reactor interface piping.

Table 1. Mass Versus Subsystem Redundancy

100 kWe Net	Single-String	JIMT Ref.			Full Redundancy	
Braytons	1x100%	1x100%	2x50%	2x100%	3x50%	2x100%
Radiators	1x100%	2x50%	2x50%	2x50%	3x50%	2x100%
PMAD	1x100%	2x100%	2x50%	2x100%	3x50%	2x100%
Mass (kg)	1836	2178	2362	2818	3543	3672
Ref. Mass (kg)	-982	-640	-456	0	+725	+854

Power Level Scaling

Figure 4 shows the mass and radiator area of the reactor power system for power levels from 20 to 200 kWe, based on the reference configuration. The total reactor power system mass for the 100 kWe design concept was 4115 kg, or 41 kg/kWe. A 20 kWe system has a specific mass of about 100 kg/kWe, while a 200 kWe system has a specific mass of 32 kg/kWe due to the favorable scaling characteristics of reactor-Brayton technology. Radiator area is relatively linear over this power range, since the basic cycle temperatures were not varied.

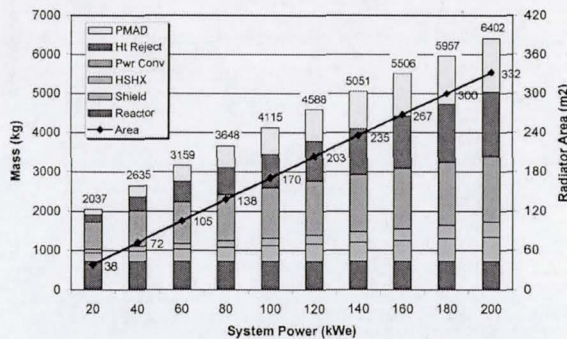

Figure 4. System Mass Versus Power

BRAYTON SUBSYSTEM

The Brayton cycle analysis discussed previously provides the basis for the Brayton subsystem design. The input design parameters are derived from previous converter development activities such as the 10 kWe Brayton Rotating Unit (BRU), 2 kWe mini-BRU, and 25 kWe Space Station Freedom (SSF) Solar Dynamic Power Module.²⁻⁴ Despite over 30 years of NASA technology development, Brayton power converters have never been operated in space. The BRU system, including the Brayton Heat Exchanger Unit (BHXU) recuperator/cooler, represents the longest duration ground test of a CBC conversion system at

38000 hours. Both the BRU and mini-BRU units were fabricated using nickel-based superalloys for the hot-end components which allow turbine inlet temperatures of about 1150 K. Scaling these designs to the 100 kWe-class seems achievable within the anticipated development timeline. However, life validation prior to launch will be a significant challenge. The proceeding sections discuss some of the Brayton-specific trades conducted during the study.

Converter Packaging

The Brayton converter subsystem consists of the turboalternator, recuperator, and gas cooler. Several converter layout options were considered as shown in Figure 5. The "stacked" layout approach was preferred based on a smaller cross-sectional diameter. This allowed the Brayton units to be located closer to the reactor to minimize interface piping length without adversely effecting shield half angle and shield mass. The overall assembly with the two 100 kWe units was 1.8 m in cross-section diameter and 2.6 m in length.

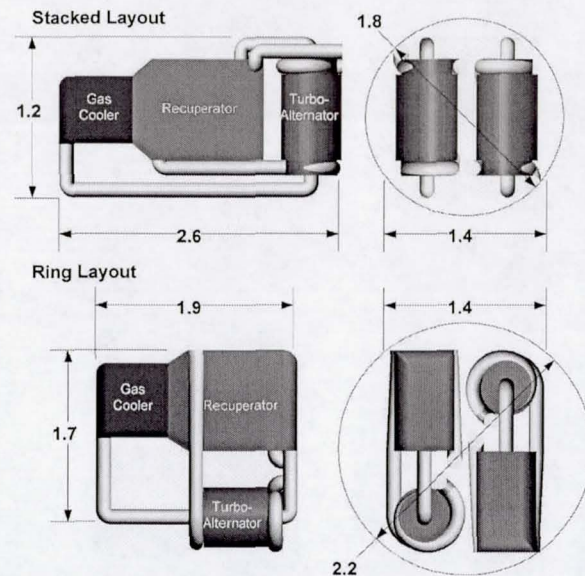

Figure 5. Converter Layout Options

Torque Effects

A first-order analysis was performed using SIMULINK to understand the effects of induced torque from rotating machinery on NEP vehicle dynamics.⁵ The analysis considered a representative 100 kWe NEP vehicle with dual Brayton units. Each Brayton unit includes a 53 cm long, 23 kg rotating assembly with two radial journal bearings and one axial thrust bearing. Primary variables included bearing stiffness (soft and hard), rotor orientation (parallel and transverse to vehicle truss), and operating scenarios (counter and co-rotating). Startup and shutdown events were also analyzed.

Table 2. Torque Study Summary

Two co-rotating Brayton units Rotor axis parallel with vehicle truss 2000 lb/in bearing stiffness	S/C Axis	Max Torque (N*m)	Max Accel (g's)
Steady State Net Bias Torque	R/P/Y	0	0
Steady State Cyclical Torque (Due to assumed rotor imbalance)	Roll	0.04	6×10^{-7}
	P/Y	26	3×10^{-5}
Single Unit Startup Transient Torque (Nominal case, 0 to 50 krpm in 10 sec)	Roll	20	3×10^{-4}
	P/Y	17	2×10^{-5}
Single Unit Shutdown Transient Torque (Worst case, 50 krpm to 0 in 1 sec)	Roll	196	3×10^{-3}
	P/Y	17	2×10^{-5}

Spacecraft moment of inertia very preliminary and conservative
Roll = 5000 Kg-m², Pitch/Yaw=574,000 Kg-m²

A sampling of the results is provided in Table 2. The net bias torque during steady-state operation is zero. Some low level cyclical torque is possible due to an assumed (very slight) rotor imbalance. A nominal 10 second rotor spin-up resulted in a 20 N-m transient torque. A worst-case, 1 second rotor shutdown resulted in a 196 N-m transient torque. These temporary torques would have to be countered by the vehicle's reaction control system. Parallel versus transverse mounting had no significant effect on vehicle dynamics. Counter versus co-rotating also had no significant effect. However, counter-rotating pairs would minimize gyroscopic precession effects on vehicle maneuvers.

Turbine Inlet Temperature

The Brayton turbine inlet temperature (or HSHX gas outlet temperature) is a key parameter that influences performance. Higher temperatures allow increases in cycle efficiency or decreases in radiator area, or a combination of both. However, the higher operating temperatures tend to increase mission risk since more advanced materials are required to handle the higher thermal stress. The baseline turbine inlet temperature was 1150 K. Temperatures above about 1200 K would require refractory alloys for the hot-end components. Figure 6 shows power conversion system mass and radiator area as a function of turbine inlet temperature. A turbine inlet temperature of 1450 K would provide a 20% reduction in mass and a 55% reduction in radiator area relative to the 1150 K reference.

HEAT REJECTION SUBSYSTEM

The HRS dominates the NEP vehicle layout, due to the large size of the radiator surface. However, a precedent exists for large space radiators with the International Space Station (ISS) Photovoltaic Radiator (PVR).⁶ The PVR is a pumped ammonia heat rejection system with deployable radiator panels. A radiator assembly includes seven 2-sided panels in series, each measuring 1.82 by 3.35 meters, for a total surface area of approximately 85 m². The aluminum honeycomb radiator panels are deployed using a scissor mechanism,

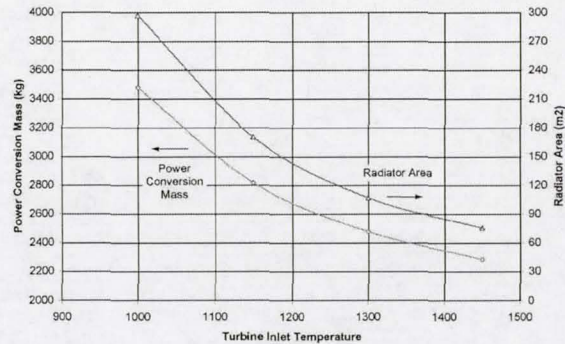

Figure 6. Mass and Area Versus Turbine Inlet Temperature

and the total heat rejection (panels, fluid loop, deployment mechanism) areal mass is 8.8 kg/m² (based on total surface area). The individual radiator panels are approximately 1.8 cm thick with an areal mass of about 2.75 kg/m² (based on total surface area).

During the SP-100 Space Reactor Program,⁷ advanced radiator studies were performed by four different contractor teams. The studies addressed radiator designs for operating temperatures of 600 and 875 K. One contractor completed a successful fabrication and test of a high temperature radiator element utilizing a potassium heat pipe and carbon-carbon fin structure.⁸ The condensing section was approximately 91 cm long and 7.5 cm wide with a 2.5 cm diameter Nb-1Zr heat pipe. The integrated heat pipe and fin assembly had an areal mass of 2.1 kg/m² (based on total surface area).

The HRS for the NEP concept study included heat transport, radiator panels, and deployment mechanism. Both the ISS radiator and the SP-100 advanced radiator studies were leveraged in arriving at the design concept. Some of the HRS design trades are discussed below.

Heat Transport Approach

A significant challenge for the heat rejection subsystem was to develop a heat transport approach to accommodate the dual-redundant Brayton power converter architecture. In order to maintain "fail-op" redundancy in the conversion system and avoid the need to carry twice the required radiator area, a cross-strapped pumped heat transport loop was devised as shown in Figure 7. The two Brayton gas coolers serve as the thermal interface to the coolant loops. Each coolant loop has dual redundant electromagnetic pumps. Each gas cooler includes two independent liquid passages, or cores, and one gas passage. During nominal operation, when both Brayton units are operating at 50% power, the liquid coolant flows through one of the liquid passages where the full waste heat load is transferred to the coolant. The coolant is

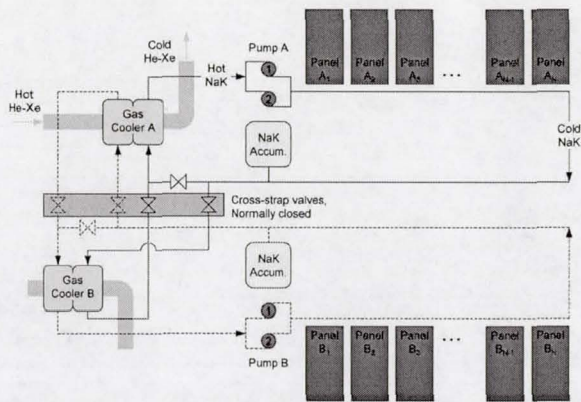

Figure 7. Radiator Heat Transport Loop

then pumped through manifolds along a series of interconnected radiator panels, forming a radiator wing assembly. The waste heat is transferred through heat pipes to the two-sided radiator surface where it is rejected to space. Each radiator wing assembly is sized to reject one-half of the total waste heat load.

In the event of a converter outage, the two pumped coolant loops continue to operate as before: coolant flow rates and operating temperatures are maintained at near-nominal conditions. However, a series of cross-strapping valves are actuated that allow both coolant loops to service the remaining gas cooler. The gas cooler heat load is increased by approximately a factor of two as the operating converter's power output is doubled to maintain full system power. Both coolant loops continue to transfer the heat to their respective radiator assemblies, which continue to dissipate one-half of the total waste heat load.

Fluids and Materials

The reference HRS design uses NaK coolant and water heat pipes. NaK provides a high specific heat coolant over a wide temperature band suitable to the Brayton cycle conditions. Alternative coolant options include hydrocarbons, fluorocarbons, organics, and water. The coolant loop containment material is stainless steel. The water heat pipes interface to the NaK coolant through evaporator sections that are contained in the fluid loop. Heat pipes provide an efficient means of spreading the heat across the radiator surface with minimal temperature drop. The heat pipes also provide greater fault tolerance than a system with pumped loop radiator panels, since the failure of an individual heat pipe would have minimal system performance impacts. The use of high-pressure water as the heat pipe fluid provides good heat transfer at suitable temperatures with relatively low risk. The heat pipe fluid containment material is stainless or nickel-based.

The radiator panels are constructed of a composite material such as carbon-carbon. Composite materials provide low mass, high conductivity and reasonable stiffness. The assumed areal mass of the heat pipe radiator panels was 2.75 kg/m² (based on total surface area). The total HRS areal mass including radiator panels, pumped coolant loop, and deployment system was 5 kg/m² (based on total surface area). The mass of the pumped coolant loop was calculated based on estimates for piping lengths, pump capacity, accumulator size, and fluid volume. The mass of the deployment system was calculated based on 30% of the radiator panel mass.

Radiator Geometry and Deployment

The main power conversion radiators have a total surface area of 170 m². Several options were considered in packaging the radiators on the NEP vehicle as shown in Figure 8. An important constraint is the reactor radiation shield cone angle. Components that are outside the shielded cone are subjected to considerably higher induced radiation levels. Since the radiators are expected to have materials and fluids that might degrade from radiation, a decision was made to maintain the full radiator surface within the shield cone angle. Maintaining the radiator panels within the cone angle also reduces the potential for reactor radiation scattering at the payload end of the vehicle.

The layouts in Figure 8 assume a 10° shield half angle and a 9 meter total axial length for the "up-front" equipment: reactor, shield, Brayton units, coolant pumps and accumulators, and truss canister. The deployable truss has a square cross-section with a 0.7 meter side. The upper layout was selected for the reference concept. This configuration uses a "stair-case" geometry consisting of ten 1.5 meter panels per wing with a 10 cm gap between panels. The first panel has a deployed height of 1.5 meters, while the last panel has a deployed height of about 4.1 meters. The advantage of this geometry is the relatively short overall length of the radiator panels (16 meters) which helps to reduce the mass of the radiator piping, truss, and power cabling.

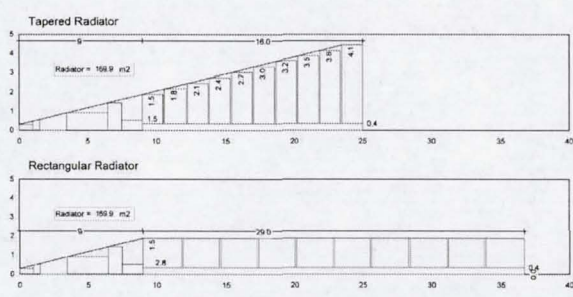

Figure 8. Radiator Geometry Options

The lower layout utilizes ten identical 1.5 by 2.8 meter panels per wing. This geometry offers greater simplicity in panel fabrication and radiator deployment, but results in a significantly greater overall radiator length (29 meters).

Deployment of the panels is accomplished with a scissor mechanism, similar to the ISS radiators, that is attached to the panels along the truss edge. Each radiator wing is assumed to have its own deployment mechanism, allowing the wings to be deployed separately and independently from the truss. The separate radiator deployment permits greater flexibility for power system startup, as described previously. It also removes the complexity of coincident truss deployment and reactor startup.

Figure 9 shows the effect of shield half angle on radiator length and relative shield mass for a range of radiator areas from 100 to 250 m². The curves assume a 9 meter "up-front" equipment length and the "staircase" radiator geometry with 10 panels per wing. An increase in the shield half angle from 10 to 15° would reduce the overall radiator length by about 25%. However, the relative shield mass would increase by about 50%.

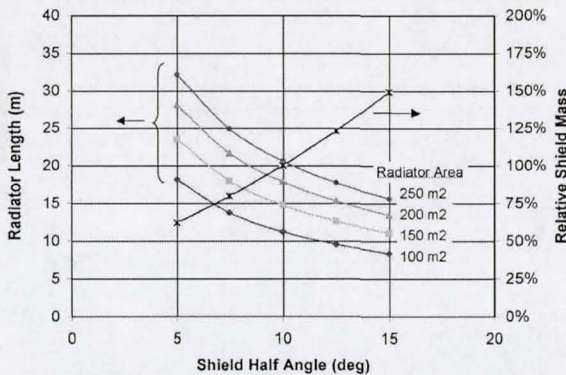

Figure 9. Shield Half Angle Sensitivities

POWER MANAGEMENT AND DISTRIBUTION

The PMAD subsystem is an often overlooked, but highly critical element of the reactor power system. This is particularly true for NEP systems that include high voltage electric thruster loads. The PMAD subsystem accepts the electrical output of the converters, modifies it as required by the bus, and distributes the power to the loads. In addition, PMAD provides control and health monitoring for the power conversion subsystem.

Similarly to the HRS, the International Space Station provides a useful reference for the PMAD concept. The ISS represents the largest power system ever developed

for space, with power levels approaching 100 kWe at assembly complete. The ISS uses a 120 Vdc primary bus architecture with modular channels. The ISS PMAD system includes several components which provide a notional starting point for NEP designs, including remote power controllers, switchgear, and shunts. Additional PMAD technology efforts are pursuing higher voltage space-rated electronic components including relays, fuses, and switchgear for 270 Vdc.

A significant challenge for the PMAD subsystem for the JIMO mission is the reactor-induced radiation environment, coupled with the severe natural radiation environment at Jupiter. Total cumulated gamma dose at the electronics dose plane for the JIMO mission is estimated at approximately 4.3 Mrad, while total neutron dose is estimated at 6×10^{12} neutrons/cm² (based on 100 mil aluminum shielding of the electronics). The contribution of the reactor to the total dose levels anticipated at the electronics is 25 krad and 1×10^{11} neutrons/cm². This radiation environment is well beyond the present state-of-the-art in radiation tolerant high power PMAD components.

The PMAD subsystem concept was developed from a bottoms-up approach. The study included analysis of power electronics, switchgear, electrical control, thermal control, and power cabling. The proceeding sections describe some of the PMAD-specific trades conducted during the study.

PMAD Architecture

Before any comparative analysis could be performed on the PMAD subsystem, an electrical architecture was required. Figure 10 shows the basic block diagram. Each of the two Brayton alternators has its own dedicated PMAD module, sized for 100 kWe. The alternator power is delivered to a 400 Vac, 1 kHz PMAD bus within the PMAD module. A buck transformer is provided at the input of the PMAD bus to reduce alternator voltage from 600 to 400 Vac, for the off-nominal case when a single alternator is providing the full 100 kWe system power. Additional work is needed to assess the PMAD performance for the minimum power coast mode condition, with two Brayton units at 10 kWe each.

From the PMAD bus, power is distributed to switchgear for the electric thruster PPU's, the spacecraft bus, the PLR controller, and the power system auxiliary loads. The PMAD module also includes a start inverter for motoring the alternator during startup and a computer processor for overall PMAD control. A 333 K cold-plate provides a thermal control interface for the PMAD radiator.

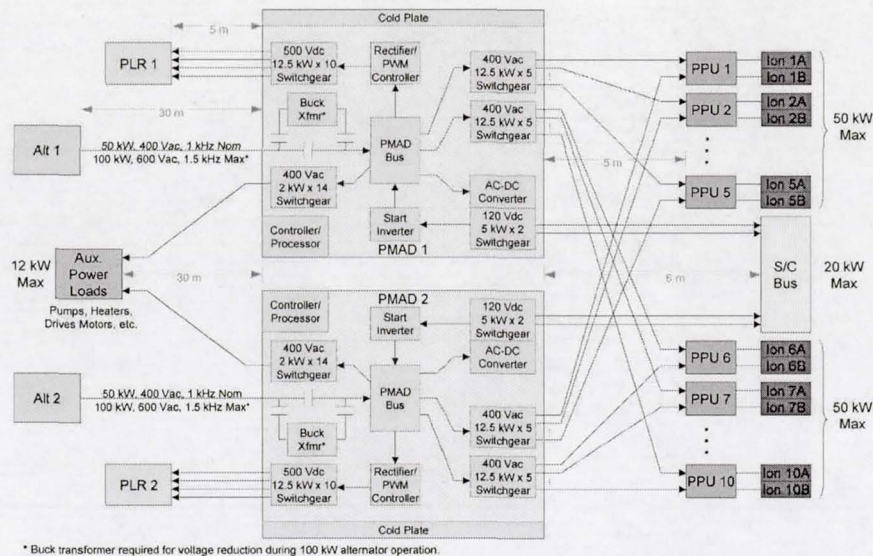

* Buck transformer required for voltage reduction during 100 kW alternator operation.

Figure 10. PMAD Architecture

The Electric Propulsion (EP) system includes ten PPUs and two ion thrusters per PPU. The PPU power distribution approach provides considerable redundancy and fault tolerance. The EP design concept includes a complete second set of thrusters to accommodate wear-out of the first set, and two redundant thrusters per set. A maximum of eight thrusters can be operated at any one time. A single PMAD module provides power switching to all ten PPUs at 400 Vac and 12.5 kWe per channel. During full power EP operation (i.e. 100 kWe) with both Brayton units operating at 50 kWe, each PMAD module powers only four of the ten PPU channels. If a single Brayton unit is operating at 100 kWe, eight of the ten PPU channels are powered. The PPU converts the 400 Vac to 4000 Vdc via a transformer/rectifier/filter for the main beam power supply load. Lower power ancillary thruster loads (cathodes, heaters, etc.) are supplied via a 120 Vdc AC-DC converter in the PPU.

The PMAD subsystem delivers 120 Vdc, and up to 20 kWe to the spacecraft bus. Each PMAD module can provide up to 10 kWe in two 5 kWe channels. The spacecraft bus delivers secondary power, at lower voltages if necessary, to all the vehicle subsystems (e.g. communications, avionics, etc.) and to the science instrument payload. The 400 Vac PMAD bus power is converted to 120 Vdc via an AC-DC converter. The PMAD switchgear interface with the spacecraft bus also serves as a power feed to the start inverter for alternator motor startup.

The PLR controller provides pulse-width modulated (PWM) switching of the PLR resistor elements to maintain constant alternator speed and load regardless

of external power demands. This approach has been successfully implemented on previous Brayton systems.⁹ Each PMAD module includes a dedicated 500 Vdc PLR load bank sized to dissipate up to 100 kWe at 773 K.

The power system auxiliary load bus provides electrical power for coolant pumps, heaters, drive motors and instrumentation using a 400 Vac distribution system. The switchgear and cabling was sized for up to fourteen 2 kW loads, assumed to be located in the general vicinity of the Brayton units.

Equipment Layout and Cabling Distance

The cabling distances indicated in Figure 10 represent a reference power distribution layout for the study. The reference layout has the PMAD subsystem located at the payload end of the vehicle, with 30 meters of cabling provided between the Brayton alternators and PMAD. The PMAD modules are within close proximity (≤ 5 meters) of the electric thruster PPUs, spacecraft bus, and PLR. The auxiliary load bus is co-located with the Brayton units at the reactor end of the vehicle. The location of the PMAD modules at the payload end of the vehicle allows the electronic equipment to share shielding with other electrical systems. This helps to minimize the spot shielding required for vehicle electronics.

The power cabling assumed for the study was tin-coated, copper conductor with Tefzel insulation, similar to what is used on the ISS, rated for 600 Volts and 150 °C. Table 3 provides a summary of the cable sizes. All of the cables were de-rated for current carrying capacity per MIL-STD-975L, for operating

temperature, and for bundling. The total power cabling mass for the five cable assemblies (alternator-to-PMAD, PMAD-to-PPU, PMAD-to-bus, PMAD-to-PLR, and PMAD-to-aux) associated with one PMAD module was 77 kg. Prior to arriving at the final power distribution layout, several alternatives were considered including locating the PMAD near the Brayton alternators. The cabling mass penalty was relatively small at about 10%, but the radiation shielding mass penalty was projected to be significant.

Table 3. PMAD Cable Sizing

	P (kW)	Volts	Ncond	Amps	AWG	L (m)
Alt-PMAD	100	600 Vac	6	53	4	30
PMAD-PPU	125	400 Vac	30	20	10	5
PMAD-Bus	10	120 Vdc	4	42	6	5
PMAD-PLR	125	500 Vdc	20	25	6	5
PMAD-Aux	28	400 Vac	42	3	20	30

Alternator Voltage

The alternator-to-PMAD cable represents the heaviest of the cable assemblies due to its long length and large wire size. The alternator power and operating voltage dictates the conductor current rating. For a given power level, higher alternator voltage results in a lower current rating and mass for the power cabling. However, the higher alternator voltage creates other concerns relative to space-rated electronic parts availability (switchgear, etc.) and corona arcing.

Figure 11 shows alternator-to-PMAD cable mass as a function of alternator voltage assuming 100 kW distribution and 30 meter transmission distance. The reference case at 600 Vac alternator output is shown at the "knee" of the cable mass curve. A 100 Vac alternator voltage would result in a 260 kg cable mass penalty. If the alternator voltage was doubled to 1200 Vac, the resulting cable savings would only be 24 kg, and additional concerns would be raised with respect to corona and parts availability.

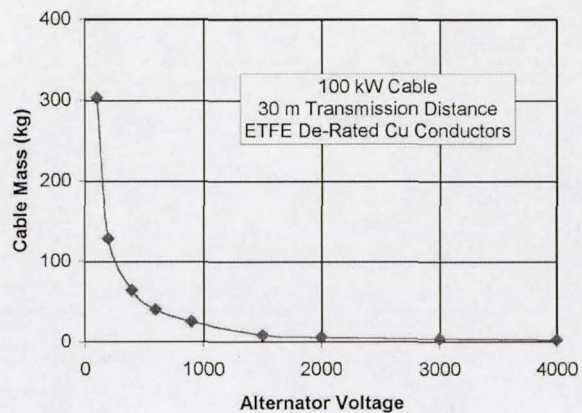

Figure 11. Cable Mass Versus Alternator Voltage

MASS AND EQUIPMENT LIST

Table 4 presents the power conversion mass and equipment list. The total mass was 2818 kg, or 28 kg/kWe. The mass fractions for the Brayton units, HRS, and PMAD are approximately 45, 30, and 25%, respectively. The reactor and shield subsystem adds about 1300 kg for a total power system mass of 4115 kg, or 41 kg/kWe. The table shows the approximate location of the equipment on the vehicle: forebody (reactor end), truss, or aftbody (payload end). A short description of the equipment is provided in the right-hand column.

CONCLUSION

The Jupiter Icy Moons Orbiter mission is currently under study by the Office of Space Science under the Project Prometheus Program. JIMO is examining the use of NEP to carry scientific payloads to three Jovian moons. A potential power system concept includes dual 100 kW Brayton converters, a deployable pumped loop heat rejection subsystem, and a 400 Vac PMAD bus. Many trades were performed in arriving at this

Table 4. Power Conversion Mass List

Power Conversion (kg)	Location			2818	100 kWe system
Brayton Power Generation				1280	1.2x1.4x2.6 m total assembly
Turboalternators	Forebody	2	136	272	50 kWe nominal, 100 kWe max per unit
Recuperators	Forebody	2	243	486	HeXe to HeXe, cross-flow, Inconel
Gas Coolers	Forebody	2	178	355	HeXe to NaK, counter-flow, stainless steel
Gas Ducting	Forebody	-	15%	167	15% of components, Inconel and stainless steel
Heat Rejection System				854	
Main Radiator Wings	Truss	2	234	468	2-sided, 85 m ² per wing, C-C panels w/HPs, 2.75 kg/m ²
Radiator Fluid Pumps	Forebody	4	24	96	2-string, redundant EM pumps
Radiator Plumbing	Truss	2	75	150	NaK-78, stainless steel piping, accumulator
Deployment Mech. & Structure	Truss	-	30%	140	30% of panels, scissor mechanism (i.e. ISS)
Power Management & Distribution				684	
Controls, Electronics, Switchgear	Aftbody	2	193	386	2 channels in one 50x50x75 cm box
Parasitic Load Radiator	Aftbody	2	36	72	6 m ² total surface area, 500°C
Alt to PMAD Cabling	Truss	2	44	88	2X 100 kW, 600 Vac, 30 m (incl cntl, ground wires)
PMAD to PPU Cabling	Aftbody	2	7	14	2X 125 kW, 400 Vac, 10 ch, 5 m
PMAD to Bus Cabling	Aftbody	2	3	6	2X 10 kW, 120 Vdc, 5 m
PMAD to PLR Cabling	Aftbody	2	14	28	2X 125 kW, 500 Vdc, 5 m
PMAD to Aux Cabling	Truss	2	9	18	2X 28 kW, 400 Vac, 30 m (pumps, heaters, motors)
PMAD Radiator	Aftbody	2	36	72	6 m ² total surface area, 60°C

candidate power system concept. System-level studies examined design and off-design operating modes, determined startup requirements, evaluated subsystem redundancy options, and quantified the mass and radiator area of reactor power systems from 20 to 200 kWe. In the Brayton converter subsystem, studies were performed to investigate converter packaging options, and assess the induced torque effects on spacecraft dynamics due to rotating machinery. In the HRS, design trades were conducted on heat transport approaches, material and fluid options, and deployed radiator geometries. In the PMAD subsystem, the overall electrical architecture was defined and trade studies examined distribution approaches, voltage levels, and cabling options.

ACKNOWLEDGMENTS

This work was performed for NASA Headquarters, Office of Space Science (Code S) under the Project Prometheus Program. The study was supported by personnel from the Jet Propulsion Laboratory, Glenn Research Center, Marshall Space Flight Center, Los Alamos National Laboratory, Sandia National Laboratory, and Oak Ridge National Laboratory. The PMAD concept was developed principally by the Electrical Systems Development Branch at GRC, and in particular James Soltis, Arthur Birchenough, and Greg Kinnach. The ion propulsion concept was developed under the guidance of Steve Oleson with support from the GRC On-Board Propulsion Branch.

REFERENCES

1. Mason, L.S., "A Comparison of Brayton and Stirling Space Nuclear Power Systems for Power Levels from 1 Kilowatt to 10 Megawatts," NASA/TM—2001-210593, January 2001.
2. Davis, J.E., "Design and Fabrication of the Brayton Rotating Unit," NASA CR-1870, March 1972.
3. Dobbler, F.X., et al., "Analysis, Design, Fabrication and Testing of the Mini-Brayton Rotating Unit (Mini-BRU)," NASA CR-159441, April 1974.
4. Staff of the Solar Dynamic Power Systems Branch, "Solar Dynamic Power System Development for Space Station Freedom," NASA RP-1310, July 1993.
5. Yu, A., Hewston, A., and Le, D.K., "Preliminary Torque Analysis of Closed Brayton Cycle Rotordynamics on a Conceptual Nuclear Electric Propulsion Vehicle," NASA TM, in process.
6. Lockheed Martin Missiles and Fire Control Website, November 2002.
http://www.missilesandfirecontrol.com/our_products/productdevelopment/SPACESTATION/product-spacestation.html
7. Truscello, V.C. and Rutger, L.L., "The SP-100 Power System," American Institute of Physics Conference Proceedings 246. 9th Symposium on Space Nuclear Power Systems. Albuquerque, NM, 1992.
8. Juhasz, A.J., "Design Considerations for Lightweight Space Radiators Based on Fabrication and Test Experience With a Carbon-Carbon Composite Prototype Heat Pipe," NASA/TP—98-207427/REV1, September 2002.
9. Mason, L.S., Shaltens R.K., and Espinosa, W.D., "Experimental Data for Two Different Alternator Configurations in a Solar Brayton Power System," NASA TM-107509, July 1997.