

CdTe focal plane detector for hard X-ray focusing optics

Paul Seller^a, Matthew D. Wilson^a, Matthew C. Veale^a, Andreas Schneider^a, Jessica Gaskin^b, Colleen Wilson-Hodge^b, Steven Christe^c, Albert Y. Shih^c, Andrew Inglis^{c,d}, Marco Panessa^{c,d}
^aRutherford Appleton Lab, Oxford, UK, OX110QX, ^bNASA Marshall Space Flight Center, Huntsville, AL 35812, ^cNASA Goddard Space Flight Center, 8800 Greenbelt Road, Greenbelt, MD 20771, ^dThe Catholic University of America, Washington, DC, 20064.

Abstract

The demand for higher resolution x-ray optics (a few arcseconds or better) in the areas of astrophysics and solar science has, in turn, driven the development of complementary detectors. These detectors should have fine pixels, necessary to appropriately oversample the optics at a given focal length, and an energy response also matched to that of the optics. Rutherford Appleton Laboratory have developed a 3-side buttable, 20 mm x 20 mm CdTe-based detector with 250 μm square pixels (80x80 pixels) which achieves 1 keV FWHM @ 60 keV and gives full spectroscopy between 5 keV and 200 keV. An added advantage of these detectors is that they have a full-frame readout rate of 10 kHz. Working with NASA Goddard Space Flight Center and Marshall Space Flight Center, 4 of these 1mm-thick CdTe detectors are tiled into a 2x2 array for use at the focal plane of a balloon-borne hard-x-ray telescope, and a similar configuration could be suitable for astrophysics and solar space-based missions. This effort encompasses the fabrication and testing of flight-suitable front-end electronics and calibration of the assembled detector arrays. We explain the operation of the pixelated ASIC readout and measurements, front-end electronics development, preliminary X-ray imaging and spectral performance, and plans for full calibration of the detector assemblies. Work done in conjunction with the NASA Centers is funded through the NASA Science Mission Directorate Astrophysics Research and Analysis Program.

Keywords: HERO, CdTe, X-ray optics, X-ray imaging, focal plane array

1. INTRODUCTION

Recent breakthroughs in the fabrication and coating of x-ray grazing incidence optics promises leaps in capability in the not too distant future. The common goal of these developments, which are being pursued by multiple groups, is the fabrication of lightweight optical elements with precise reflective surfaces, to enable a new class of suborbital and in-space X-ray observatories. These observatories demand large effective areas combined with high angular resolution across the soft and hard X-ray (HXR) regime, to be able to address the outstanding science questions that follow on the heels of existing observatories. As the quality of these optics continues to improve, there is likewise a need to develop a complementary class of detectors that can support them by sufficiently oversampling the optics at a given focal length with good efficiency. This is particularly true in the HXR band (10 keV to \sim 100 keV), where an order of magnitude improvement in the angular resolution for X-ray optics over current state-of-the-art is becoming feasible.

Supported through the NASA Astrophysics Research and Analysis, the Rutherford Appleton Laboratory (RAL) is working with the NASA Goddard Space Flight Center (GSFC), and the Marshall Space Flight Center (MSFC) to prepare multi-pixel, fine-pitch (250 μm), 3-side abutable CdTe detector arrays for use on a suborbital (and eventually satellite) HXR observatories. These detectors are made possible by the development of the HEXITEC (short for High Energy X-ray Imaging Technology) ASIC developed at RAL. Detector systems including the HEXITEC ASIC are being used regularly in a laboratory environment. This ASIC is unique in that it combines fine spatial resolution with fast readout capability (10k frames per second) and efficient spectroscopy in the HXR band.

Science drivers

There are multiple science topics that are only achievable from a HXR observatory with high angular resolution (\sim 5 arcsecs). The primary reasons for improved angular resolution are (1) resolving extended sources on fine spatial scales, (2) mitigating source confusion in crowded fields, and (3) for efficient observing through increased sensitivity. In this section we will focus on two main science applications, astrophysics and solar physics.

Astrophysics

NASA's Nuclear Spectroscopic Telescope Array (NuSTAR), which is an orbiting HXR telescope, has opened up the field of HXR astrophysics with discoveries ranging from asymmetrical explosion of supernova through detailed titanium-44 mapping, to determining the covering factor of Compton-thick Active Galactic Nuclei (AGN)¹. A HXR telescope that makes use of focusing optics is also ideal for probing the centre of the Milky Way, which is rich in HXR due to its high concentrations of stars, intense star formation activity, and the presence of its supermassive black hole Sgr A*². Recent observations with NuSTAR of the inner 10 parsecs of the Galactic Centre has detected the presence of a HXR component (20 keV - 40 keV range) which might indicate the presence of larger than expected population(s) of a variety of sources (e.g. accreting white dwarfs, low-mass X-ray binaries or millisecond pulsars, etc.). The presence of these sources provides new insight into the evolution and dynamics of the Galactic Centre³. Other sources that would benefit from such an observatory are: pulsar wind nebula, which are expected to have detailed structure and extended emission resulting from the magnetized stellar wind interacting with the surrounding medium; supernova shock regions to determine the acceleration process by studying the emission morphology⁴; and luminous X-ray binaries in our Galaxy and in the Large and Small Magellanic Clouds.

This new view of the universe is currently defined by an angular resolution of just under 1 arcminute Half-Power Diameter (HPD); meaning that half the reflected flux from a point source falls within this angular diameter. A hard X-ray observatory with an angular resolution that is at least 10x better than that of NuSTAR would enable a new class of science that is on-par with the soft X-ray regime (<10 keV), where existing observatories have comparable (and better) angular resolution.

Solar physics

The Sun is the most energetic natural particle accelerator in the solar system, producing ions up to tens of GeV and electrons to hundreds of MeV. Large solar flares are the most powerful explosions in the solar system, releasing up to 10^{32} – 10^{33} ergs within 10^2 – 10^3 s. Observations show that flare-accelerated >20 keV electrons and >1 MeV/nucleon ions can contain a significant fraction, up to ~ 10 – 50% of this energy⁵, indicating that the particle acceleration and energy release processes are intimately linked. While it is clear that the energy released in these events must be stored in the magnetic field, the particle-acceleration processes are not well understood. HXR observations of bremsstrahlung X-rays from energetic electrons are vital to understanding energy release and particle acceleration in low-density plasmas at the Sun and in astrophysical settings.

HXR observations are a powerful diagnostic tool, providing quantitative measurements of flare-accelerated electrons. Since bremsstrahlung emission depends on the density of the ambient medium, electron beams moving in the relatively tenuous solar corona suffer very few collisions, losing little energy and producing faint HXR emission that is directly related to the electron spectrum. It is only when electron beams enter the higher-density chromosphere that they produce relatively intense HXR emission and lose energy quickly. Subsequently, heated thermal plasma fills the flare loops and produces HXR thermal emission up to ~ 30 keV in the largest flares.

Due to the limited sensitivity and dynamic range of current HXR instruments (e.g. RHESSI⁶), observations generally show us only where energetic electrons are stopped, but not where they are accelerated, nor their path through the corona or how they sometimes escape from the acceleration site. RHESSI (and all past solar HXR) observations are limited in three ways: (1) low effective area, (2) large non-solar background, and (3) limited dynamic range due to indirect imaging⁷. The rare RHESSI observations of coronal HXR sources that do exist have provided tantalizing evidence of the unusual efficiency of the acceleration mechanism or the inadequacy of our current models⁸. In order to observe accelerated electrons directly in the acceleration site in the corona and get a complete picture of solar flare electron acceleration and transport, new observations using direct X-ray imaging with high angular resolution are needed.

Relevant missions

There are several mission concepts that are actively being funded or are under study that would benefit from higher resolution optics and matching detectors.

One active suborbital program that uses focusing optics is the HXR telescope HEROES⁹ (High Energy Replicated Optics to Explore the Sun), balloon borne observatory. The HEROES payload is based on the HERO (High Energy Replicated Optics) program, which was developed at MSFC under the leadership of Dr. Brian Ramsey¹⁰ and has a long heritage of successful flights (4 over 6 flight campaigns). The HEROES telescope consists of 8 X-ray optics assemblies, each of which houses 13 or 14 individual optics, with a measured angular resolution of ~26 arcsec (HPD). These assemblies are mounted on a carbon-fibre optical bench 6-m from a matching array of focal-plane detectors. The detectors are in-house-fabricated imaging gas-scintillation proportional counters (GSPCs) with performance typical for this type of detector: absorption efficiency ranges from 98% at 20 keV to 80% at 70 keV; energy resolution at 60 keV is < 5% FWHM; measured spatial resolution of 400 μm at 30 keV is just sufficient for a 26 -arcsec, 6-m-focal length system.

Another successor to the HERO program is the solar-dedicated sounding rocket program, FOXSI, (Focusing Optics X-ray Solar Imager). FOXSI consists of 7 mirror modules each with 7 nested shells with a two meter focal length^{12, 13, 14}. This focal length is mainly constrained by the sounding rocket platform and it provides coverage from 4 to ~15 keV. The detectors are 500 μm thick double-sided silicon strip detectors. The angular resolution achieved in this mission was about 20 arcsec (HPD), 5 arcsec FWHM, made possible by new advances in alignment between shells.

A follow-on proposed payload to both HEROES and FOXSI is the SuperHERO HXR telescope¹⁵. The SuperHERO balloon mission would, similar to HEROES, observe astronomical objects as well as the Sun during the same flight. The SuperHERO payload will employ the same optical mounting scheme as used for FOXSI to improve the optics assemblies' angular resolution. Improved angular resolution necessitates improved detector requirements that are satisfied by the HEXITEC detectors. This includes: 250 μm pixel pitch and 160 x 160 pixels, with good energy resolution and quantum efficiency over all energies and the high rate capabilities needed for solar observations.

With the experience from this balloon payload, the HEROES/HERO flights, and the FOXSI flights, future space missions are currently being planned both for astrophysics and solar physics.

Regarding Astrophysics space-based missions, MSFC investigators are defining a SuperHERO NASA Medium Explorer (MIDEX) orbiting payload concept. SuperHERO-orbiter would have improved optics with ~5 arcsec resolution and 20-m focal length. As the focal length is extended over that of SuperHERO-suborbital instrument, the improvement in the optics does not necessitate a change of the detector requirements.

In addition to the SuperHERO-orbital mission, there are two stand-alone probe-class mission concepts that were submitted to the Physics of the Cosmos, 2011 RFI "Concepts for the Next NASA X-ray Astronomy Mission". Probe-class missions are defined as NASA missions costing less than \$1B, but more than \$200M (i.e. the cost of a NASA MIDEX). These two missions are the BEST (Black Hole Evolution and Space Time) Observatory, led by H. Krawczynski at Washington University in St. Louis, and the HEX-P (High Energy X-ray Probe), which is led by F. Harrison at California Institute of Technology¹⁶. BEST, combines a HXR imaging spectrometer (5-70 keV) with a broadband X-ray polarimeter (2-70 keV). The BEST imaging detectors are designed to have a pixel pitch of 240 μm , and should have good energy resolution (1.5 keV FWHM) over the relevant band-pass. HEX-P, is an X-ray imaging spectrometer similar to NuSTAR, but with larger effective area and a broadband (0.1-200 keV) response. The HEX-P detectors are a hybrid of Si CCD and pixelated CdTe detectors. In order to minimize the need for detectors with finer pixels than NuSTAR and achieve their desired angular resolution of 15 arcsec, HEX-P proposes to have a focal length of 20 m (compared to that of NuSTAR, which is 10 m). To better match its optics with higher performance (i.e. better than 10 arcsec angular resolution), a finer pixel detector or longer focal length would be necessary.

On the solar side, the recent Heliophysics Decadal Survey¹⁷ recommended the SEE 2020 mission. Short for the Solar Eruptive Events (SEE) mission, it's primary goal is to image electron and ion acceleration in SEEs with "unprecedented" resolution. This was rated as the highest priority for a Living With a Star strategic mission and it's primary goal include (1) investigate how magnetic energy is suddenly released to produce both flares and coronal mass ejections and (2) investigating how flares accelerate electrons with high efficiency. Both of these goals are addressed by a grazing incidence focusing X-ray imager called FOXSI at the end of a 10 m boom. The panel also recommended that this instrument would be appropriate as a stand-alone SMEX mission. This concept is currently being studied by GSFC. It consists of 3 optics modules with a 15-m boom. At this distance the HEXITEC detectors pixel scale corresponds to 3.4

arcsec which oversamples the 5 arcsec FWHM of the optics. A 2x2 configuration (160x160 pixels) of the HEXITEC detectors provides a field of view 9 by 9 arcminutes. Combined, these telescopes would provide up to 300 cm² of effective area from ~3 to 40 keV a factor of ten better than has been available and like a factor of 100 times better sensitivity.

X-ray focusing optics developments

The X-ray optics for the aforementioned missions are typically in a Wolter Type I configuration. To focus incoming X-rays, two reflections are required; first from a parabolic surface and then from a hyperbolic surface. This configuration has been described in detail in the literature¹⁸.

The focus here will be on the optics development at MSFC, as these optics are currently a factor of two better resolution than any other HXR optics either currently in use, or being fabricated¹⁹. The MSFC mirror fabrication method uses a single highly polished mandrel which is then electro-coated to produce many individual mirrors. Such mirrors do not need to be polished since they retain the finish and shape of the polished mandrel. In order to provide significant energy coverage and effective area, many single shells with different radii are nested using a spider mount to form a telescope module. Although many mandrels are necessary to create a telescope module, a set of mandrels can be used repeatedly to produce many telescope modules at low cost. Single optics shells fabricated in this way have been measured to have better than 15 arcsec resolution (HDP). Useful total collecting area is achieved by employing multiple shells nested within each other forming individual mirror modules. The HERO/HEROES mirror modules have an average angular resolution of ~26 arcsecs, mainly due to assembly errors. However, we know that this can be improved to 20 arcsecs HPD by using a new assembly technique that was successfully used for the FOXSI sounding rocket payload.

The problem of how to produce lightweight X-ray optics while maintaining good angular resolution has yet to be completely resolved. Many groups have made significant progress in these areas. MSFC, for example, is actively developing the capability to directly figure and polish full-shell glass and metal optics as well as novel approaches for assembling very-thin shell optics. The goal is to develop light-weight full-shell optics with ~ 5 arcsec HPD angular resolution. This full-shell optics can be further improved with another active in-house development involving a differential deposition process. In this process, coatings are selectively deposited on the surface of the optic to further improve its figure²⁰.

To complement this significant improvement in angular resolution, a HXR detector with matching performance is desired. Specifically, this detector should have a large number of fine pixels of sufficient size to adequately sample the telescope PSF over the entire field of view, with good energy resolution and efficiency over the HXR band. An appropriate level of over-sampling is to have 2-3 pixels within the HPD. Excessively over-sampling the PSF will increase readout noise and require more processing with no appreciable increase in image quality.

CdTe and CZT detector benefits

One intrinsic advantage of high atomic number solid-state detectors for space based missions is that high X-ray detection efficiencies can be achieved with a small active volume so that the background flux is minimized. This improves the background rejection efficiency and reduces the size of anti-coincidence screens and can reduce the mass of the detectors while keeping the same focal plane area. The inherent stability and ease of containment of the solid state detectors is also a major advantage. CdTe detectors have now been proved to give excellent spectroscopic performance particularly in small pixel readout format. The advantages of small pixel readout is that the intrinsic capacitance of the pixel is low which reduces noise and leakage current and also the increased numbers of channels improves throughput, circumventing pileup issues. The other significant advantage achievable with pixel detectors is the so called 'small pixel' effect which turns the readout into a single carrier device where the slower moving holes do not play a part in signal generation. This can mitigate some signal artefacts seen in single element devices.

Now that the interconnection and readout technology of small pixel CdTe detectors has been demonstrated in several instruments, the intrinsic advantages can be utilised in future balloon and space-based instruments.

2. INSTRUMENT REQUIREMENTS

Hard X-Ray telescope configurations for future missions

Two example HXR telescope configurations are discussed. The first pertains to the SuperHERO suborbital payload and the second to a SuperHERO-orbiting payload. The SuperHERO suborbital payload optics is expected to have 20 arcsecs (HPD) over a 6-m focal length, which converts to $\sim 580 \mu\text{m}$ resolution at the focal plane. A detector with a pixel size of $250 \mu\text{m}$ will oversample the optics by 2.3 times, which is within the desired range. Of course, the detectors must also have high efficiency in the HXR region, good energy resolution, low background, low power requirements, and low sensitivity to radiation damage²¹. The ability to handle higher counting rates is also necessary for solar observations. The SuperHERO orbiting, or MIDEX, payload would consist of 3 modules, each with 45 nested mirror shells, with an angular resolution as good as 10 arcsecs (5 arcsecs goal) and 20-m focal length²². This converts to $\sim 970 \mu\text{m}$ ($485 \mu\text{m}$ goal) at the focal plane, and so a detector with $250 \mu\text{m}$ will oversample the optics by roughly 3.9 times (2.0 times).

Detector needs & HEXITEC capability

In order to achieve the angular resolution described above, the focal plane array geometry needs to have $250 \mu\text{m}$ pixels and a focal plane area of $40 \text{ mm} \times 40 \text{ mm}$. This necessitates arraying 4 detector modules into a 2×2 array (each detector module has 80×80 pixels). For obvious imaging performance reasons the pixels in each of the modules need to be aligned precisely to one another in the 4 detector array, Figure 1. The geometry of the current focal plane devices is described below.

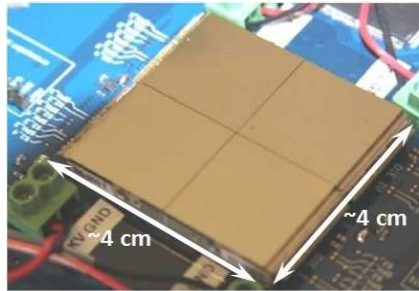

Figure 1. Four modules mounted together in a prototype system.

The pixels on a single module are photo-lithographically produced with a resolution below $1 \mu\text{m}$ so the precision of pixels within one module is not an issue. The alignment of the modules with relation to each other and precisely to the rest of the instrument has been more challenging and has required a unique solution. The CdTe detectors are bump bonded to the ASICs with gold studs on the ASIC aligned to silver glue on the detector. After this process is completed, only the back of the ASIC and the back of the detector are visible. Neither of these have alignment features. The only way to align the pixels from one module to one another is to use the edges of each module.

Each of the modules has two accurate apertures in the back of the aluminium base of the module. One is round and one is a slot. These are used to mount the modules accurately on an alignment block with better than $50 \mu\text{m}$ precision. The detectors are accurately positioned on the aluminum module base by using a custom mounting jig to align them. First the base is inserted in the jig using 2 dowels and matching holes. The jig has 2 precision sides which are machined accurately with reference to the dowel holes. The detector and ASIC assembly is glued to the module base while making sure the edge of the detector is pressed against the 2 precision edges of the jig. When the glue is set, the edge of the detector is thus precisely aligned to the dowels used to position it. This method of alignment requires that the edges of the detector are aligned to the pixels. In the case of our CdTe this is accurate to of order $10 \mu\text{m}$.

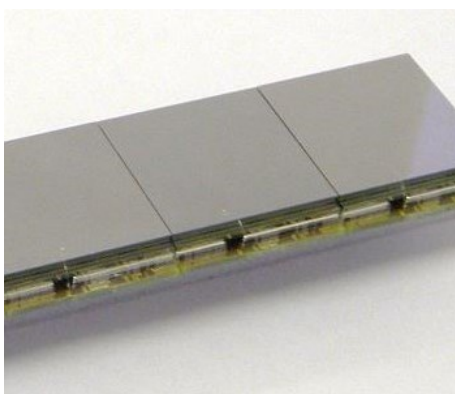

Figure 2. Modules mounted on an alignment plate.

Each module is fully electrically tested and used to image radiation before it is mounted together with the other modules. We have test systems which can cool, power and readout the modules while applying ^{241}Am characteristic decay radiation. After testing, the modules are accurately placed on an alignment cooling plate again using the same 2 dowels and holes. Using this method we can align the modules very accurately with $170\ \mu\text{m}$ gaps (less than one pixel) between the modules as shown in Figure 2.

3. READOUT DESCRIPTION

Detector module and electronic readout description

Over the past seven years RAL has been developing a readout system for pixelated CdTe and CZT X-ray detectors. While good spatial resolution is important for imaging applications, the unique design driver of the system was to have very good energy resolution over the whole region where CdTe detectors have good efficiency. The ‘Hyperspectral imaging’ concept is to measure the energy of every individual photon interacting in the CdTe conversion material²³. This technique is used to provide the best energy resolution and efficiency in the region of 5- 200 keV photon energy.

The current assembly uses a 1 mm thick piece of CdTe that is bump bonded to an Application Specific Integrated Circuit (though it is important to note that thicker CdTe can be supported). This HEXITEC ASIC reads out the charge deposited in each $250\ \mu\text{m} \times 250\ \mu\text{m} \times 1\ \text{mm}$ voxel of the CdTe. In order to achieve the best energy resolution and efficiency, all the pixels are read out all of the time, with a very low-noise amplifier in each pixel. If the absorbed photon produces charge that is shared between two pixels, these signals are summed together in post processing software. The advantage of this method is that there is no artificial lower threshold of operation and all the data is available for analysis to investigate subtle effects in the data. Also, different charge sharing correction algorithms can be compared. The efficiency is high due to $> 95\%$ absorption of photons up to 60 keV with the 1 mm of CdTe, and also there is approximately only a 1% deadtime in the system due to readout of the data frames. The frames are readout at 10 kHz which allows dynamic imaging with a time stamp on the photons of 100 microseconds. Combining this dynamic performance with the X-ray spectroscopic performance and the 20 mm x 20 mm active area, the Hexitec ASIC and detector represents a good match for hard X-ray focusing optics in the range up to 80 keV.

The central component of the readout system is the Hexitec ASIC. This has an 80×80 array of pixels each with a preamplifier followed by a signal shaper and then a peak-track-and-hold circuit and then a rolling shutter readout system. Each preamplifier is connected via a $55\ \mu\text{m}$ bond pad to the CdTe detector. The preamplifier detects any charge induced on the pad by the movement of charge carriers in the CdTe. One electron-hole pair is produced by every 4.5 eV deposited in the CdTe. This charge is drifted by an applied field across the detector and it is this drift which induces the charge signal. The $250\ \mu\text{m}$ pixels create a field distribution in the detector so that only the electrons are sensed by the circuit (small pixel effect). This charge is collected on a 15 fF feedback capacitor which produces a large voltage gain in

the system. After the preamplifier, a 2 microsecond shaper is used to AC couple the circuit and to filter high and low frequency noise. The maximum peak value in a frame time is stored on a further capacitor for readout. If there is a low value signal in a frame time this will be overwritten by a higher value, so there is an inherent maximum occupancy in the system. All 80 x 80 amplifiers perform this measurement continuously. The rolling shutter readout selects a row of 80 held peak output voltages and transfers them to a multiplexer. The multiplexer shifts the analogue voltages to an output driver and off of the ASIC. There are 4 multiplexers, each of which handles 20 columns to speed up the output process. 14 bit ADCs are used to digitize these serial streams of data at 20 MHz. This data is then packaged by an FPGA and sent directly to computer storage. In some systems we use Camera link and others we send to Gigabit Ethernet. For flight systems the raw pixel data will have to be analysed and probably compressed into spectrum-per-pixel format.

The FPGA control also has to supply clocking signals to sequence the readout of the ASIC and to control several housekeeping functions. The detector and the ASIC have to be held at a fixed temperature to alleviate drifts in output voltage. We have a Peltier controlled system to stabilize the temperature to 1 degree C. There is a temperature sensor integrated on the ASIC to readout the temperature which has to be held between 0 and 15 C for best operation of the CdTe.

A high voltage supply of 300 V to 500 V is incorporated to bias the detector and in order to operate this at low temperature we have an electronic dehumidifier in the system. CdTe detectors have an artefact called polarization. The effect of this is that the active volume in the detector decreases if the detector is left biased for too long. This effect is dependent on the material quality, the material thickness, the temperature of operation and the exact detector structure. A related effect is that the leakage current of the device, which is predominantly due to the edges of the device, increases with time. At some point, this increased leakage causes the detector to become unstable and produce high noise. To mitigate these effects, we have to periodically turn off the bias to the detector for a few seconds. Depending on a number of factors, including the temperature, this has to be done every few minutes to few hours depending on the criteria above. This requires the system to have a pulsed power supply.

All these features have been successfully integrated and there are stand-alone systems ranging from a compact (210 mm x 55 mm x 55mm) unit with a single 20 mm x 20 mm active area detector, up to a system with 100 mm x 100 mm active area with 5x5 modules. RAL has a reliable gold-stud and silver-glue bump bonding technique in order to bond the 80 x 80 pixel array without affecting the performance of the CdTe. The essential feature of this is that it does not apply pressure to the CdTe and the temperature does not exceed 120°C. Preliminary vibration tests at NASA GSFC have shown that this bonding will be robust for balloon flights but more vigorous tests are needed to confirm space flight compliance.

Charge sharing is a big issue with 250 µm pixels in a 1 mm thick detector. If adjacent pixels have signals in the same frame it is assumed there is charge sharing. At typical operating conditions for 1mm thick CdTe, 36% of events show signal divided into to two pixels. The two signals can either be added together and allocate to the pixel with the higher signal or both signals can be rejected. Adding the signals increases efficiency but does not produce quite as good spectra as charge shared discrimination. This processing is performed on the digital data stored in computer memory. Both algorithms can be performed on the data and the best selected depending on the most important criteria for the science.

4. CdTe MODULE MEASURED PERFORMANCE

Detector module performance

As part of the development of the HEXITEC spectroscopic imaging technology at the STFC RAL, a large number of CdTe small pixel detectors from Acrorad (Japan) have been characterized. These CdTe detectors were 1 mm thick and were fabricated with aluminium Schottky pixels to reduce leakage currents. Recently a large area tiled array (10 cm x 10 cm) of 25 HEXITEC devices has been produced^{24, 25} which required 40 of these CdTe modules to be assembled and tested.

Across this sample of 40 detectors differences were observed in electrical and spectroscopic performance at an operating temperature of 20°C. Variation in the resistance of the edges of each CdTe crystal, due to wafer dicing²⁶, meant that the optimum operating bias voltage for each detector was different. In the 10 cm x 10 cm system a common supply is used

to provide the bias to each module. A bias voltage of - 300 V was found to be optimal and produced stable leakage currents and high resolution spectroscopy at an operating temperature of 20°C.

As described above, the use of small pixel geometry means that significant numbers of interactions will involve charge sharing between multiple pixels²⁷. As the HEXITEC detector records both the position and precise energy deposited for each interaction this allows different charge sharing correction algorithms to be applied to the data in post-processing. Figure 3 compares the spectroscopic performance of a CdTe detector flood illuminated with an ²⁴¹Am gamma ray source at -300 V, each spectra shows the effect of the different charge sharing correction algorithms on the detector performance. If no correction is applied to the data (a) then a large background of low energy events is observed that reduces the spectroscopic performance of the detector at energies lower than the main photo-peak (60 keV). In spectrum (b) events where charge is detected in neighbouring pixels during the same frame are not included in the spectrum improving the overall performance. In the final spectrum (c), those events suspected of involving charge sharing are summed together with the event assigned to the pixel with the largest proportion of the detected charge.

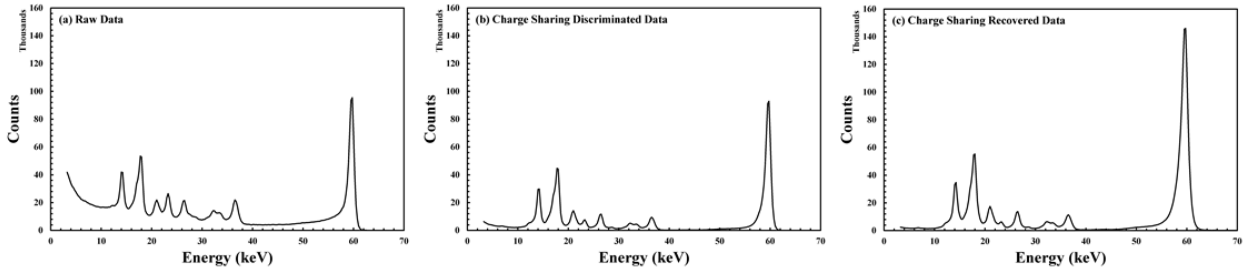

Figure 3: The summed ²⁴¹Am spectrum from an entire HEXITEC CdTe detector biased at -300 V at a temperature of 20°C. The spectra are shown with (a) no correction for charge sharing, (b) with charge sharing events removed and (c) with charge sharing events recombined.

Under these operating conditions a total of 51 % of events were found to involve charge sharing. Table 1 compares the effect of each of the charge sharing correction techniques in terms of the FWHM and peak-to-valley (P2V) ratio of the primary photo-peak at 59.5 keV and the associated neptunium fluorescence peak at 13.9 keV. The use of the discrimination algorithm that removes shared events produces the highest resolution spectroscopy but, under these conditions, removes over 50 % of events. By recovering the charge sharing events the peak-to-valley ratio improves compared to the raw data but there is a broadening of the main photo-peak due to the addition of noise in individual pixels.

Table 1: A comparison of the performance of different charge sharing correction algorithms on the performance of a CdTe detector operated with a bias voltage of - 300 V at 20°C.

Algorithm	FWHM _{@14keV} (keV)	P2V _{@14keV}	FWHM _{@60keV} (keV)	P2V _{@60keV}
None	1.3	1.7	1.1	3.5
Discrimination	0.9	3.1	1.1	13.8
Addition	0.9	3.5	1.6	11.2

The performance of the 10 cm x 10 cm system containing 25 modules was characterized using the ²⁴¹Am sealed source. The detector was operated at - 300 V at 20°C and the spectroscopic performance per pixel evaluated from the FWHM of the 60 keV photo-peak after the removal of charge sharing events, see Figure 4. Measurements showed that 91% of pixels achieved a FWHM of 2 keV or better while only 3% of pixels were found to be non-spectroscopic. The poor pixels were due to a variety of issues including bond failures, the presence of crystalline defects and damage at the crystal edges that occur during fabrication and assembly.

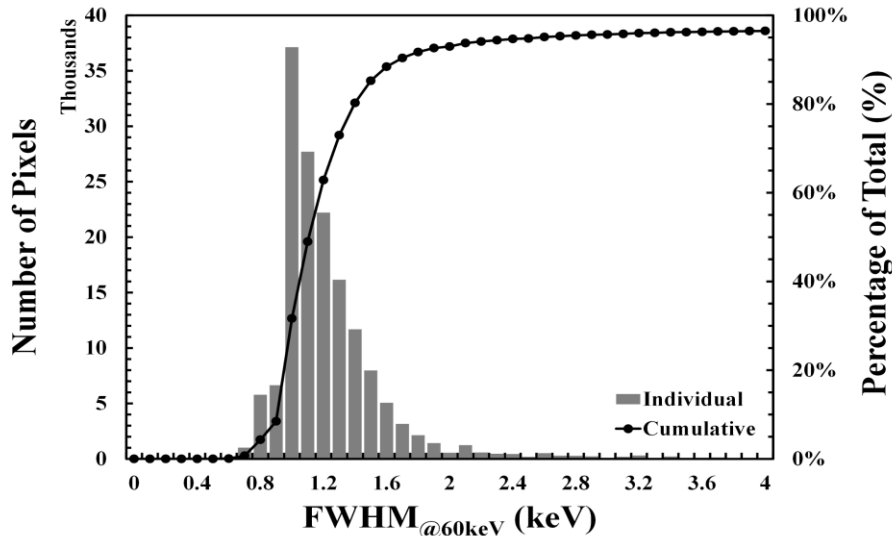

Figure 4: The distribution of FWHM values of the 60 keV photopeak across all 160,000 pixels of a 10 cm x 10 cm CdTe detector system based on the HEXITEC technology.

The smaller area (4 cm x 4 cm) of the detector required for the SuperHERO project means that it is feasible to operate the detectors at lower temperatures; this will allow the operating bias voltage to be increased closer to the values used in single module HEXITEC systems. Increasing the bias voltage will improve the charge sharing collection efficiency and will reduce the proportion of charge sharing events within the detectors. Operated under these conditions, single module systems have been shown to achieve FWHM of < 1 keV at 60 keV²⁸.

5. Results with flight compliant parts

A collaboration between GSFC, MSFC, and RAL is currently being funded by the NASA Astrophysics Research Program (APRA) to develop and qualify the HEXITEC detectors for suborbital and space-flight missions. The primary metric for assessing the maturity of a technology for space flight is the technology readiness level²⁹. The primary fundamental goal of this effort is to develop a HEXITEC-based detector system which includes read-out electronics that have the appropriate TRL level for a satellite-based mission (generally TRL-6). A preliminary laboratory read-out system is currently being tested which includes commercially available parts that are equivalent to TRL 6 or higher. Referred to as PRAXIS, this single board consists of a Field Programmable Gate Array (FPGA), amplifier, digitization circuitry, a memory unit, a USB test interface, voltage regulation, and temperature reading. The FPGA collects the digitized data from the ASICs, performs X-ray detection, and reports detected X-ray data including time and pixel number. X-ray detection is performed by the instrument because the raw digitized data are generated at a rate far beyond what can be stored or transferred. ADCs similar to the RHF1401 were chosen. A ProASIC3-3000 FPGA was chosen for these tests which are similar to a RT-ProASIC3-3000 or RTAX-2000 which can be supplied in a space-qualified version.

X-ray detection is performed by the FPGA because the raw digitized data are generated at a rate far beyond what can be stored or transferred. ADCs similar to the RHF1401 were chosen. A ProASIC3-3000 FPGA was chosen for these tests which is similar to a RT-ProASIC3-3000 or RTAX-2000 which can be supplied in a space-qualified version.

Preliminary results have been obtained from the Praxis board, operating at a temperature of approximately 25°C. For these tests the detector was placed in the presence of an ²⁴¹Am source, which features a photo-peak emission line at 59.5 keV. With the low rate source available a total exposure time of 4 hours was used in order to generate sufficient counts to investigate spectra on a pixel-by-pixel basis. For these tests, a software threshold of approximately 30 keV was set in order to focus solely on the emission from the strong ²⁴¹Am 59.5 keV photo-peak.

Analysis of the individual pixel spectra revealed the presence of the 59.5 keV in almost all pixels. To characterize the peak, a Gaussian model was fit to the spectral data in the vicinity of the emission peak for each pixel. From this the

distribution of peak positions and widths can be derived. For this preliminary dataset, we find substantial variation in the peak position, primarily due to gain variation between different detector segments. The peak width distribution is centred at ~ 1.4 keV, with a FWHM of approximately 1 keV. As charge-sharing has not been taking into account these results are consistent with those shown in Figure 4.

These preliminary results show that similar performance can be achieved using space-qualified parts. Future work is planned to address charge-sharing and a cooling system is currently being designed to cool the detector to -10 C which should enable even better performance.

6. FUTURE DEVELOPMENTS AND TIME SCALES

These preliminary laboratory tests have shown that the HEXITEC detector system has promise for space applications. With this knowledge, a full detector system is being designed for space-based observations. The major considerations in this new design are mechanical and thermal constraints. In addition, the readout system must read-out four detector ASICs rather than just one. This requires that the PRAXIS card electronics must be distributed onto two cards: an Analog Front End (AFE) card that is housed very close to the ASICs, and an Instrument Card that sits further away where it has more space and its heat will not couple into the detector. In order to pack more digital processing capability into the same footprint, new integrated circuit technology is being leveraged. For example, this design includes a new FPGA from Microsemi (RTG4). The RTG4 builds upon the RT-ProASIC3, but is a much more powerful and will be useful in handling four times the amount of data. A more advanced ADC from Texas Instrument (ADS5272), which is being space-qualified is also being considered in this design. The ADS5272 is an 8-channel 65-MHz ADC. Compared to the RHF1201 has a smaller footprint yielding mass and power savings. Figure 5 is our planned instrument electronics architecture.

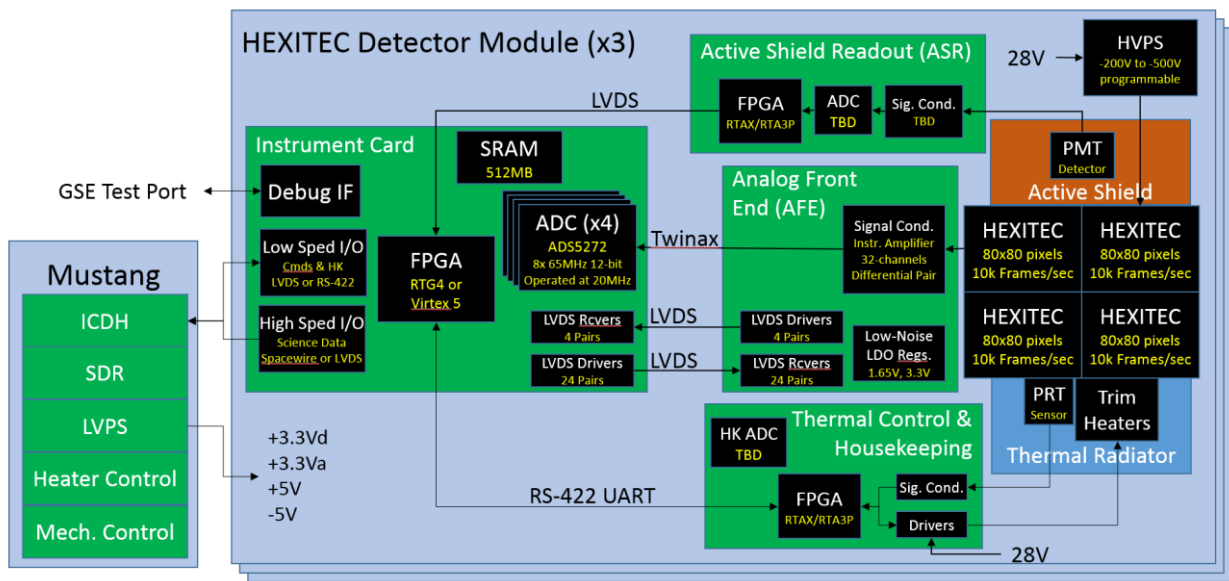

Figure 5: System overview of PRAXIS readout.

7. SUMMARY

Rutherford Appleton Laboratory (RAL) is working with NASA Goddard Space Flight Center (GSFC), and Marshall Space Flight Center (MSFC) to prepare multi-pixel, fine-pitch ($250 \mu\text{m}$), 3-side abutable CdTe detector arrays for use on a suborbital and space-based HXR telescopes. This work, supported through the NASA Astrophysics Research and Analysis, will develop an electronic readout chain and mechanics suitable for use with the HERO and SuperHERO focussing optics configurations. The $250 \mu\text{m}$ pitch CdTe detector can deliver the required ~ 5 to ~ 10 arcsec resolution

with the necessary focal length. This collaboration has demonstrated ~1 keV FWHM over the X-ray spectrum from 5 keV to 80 keV which suits the requirements for the astrophysics and solar-physics observations cited.

Acknowledgements

Part of this work is supported by NASA under the grant NNN13ZDA001N-APRA: Astrophysics Research and Analysis (APRA). We would like to thank Louis Kaluzienski, X-ray Astrophysics APRA Program Manager, and as well as Michael Garcia, the APRA lead for funding this work.

References

- [1] www.nustar.caltech.edu
- [2] Genzel, R., Eisenhauer, F. and Gillessen, S., “The Galactic Center massive black hole and nuclear star cluster,” *Rev. Mod. Phys.* 82, 3121–3195 (2010).
- [3] Perez, K., Hailey, C. J., Bauer, F. E., Krivonos, R. A., Mori, K., Baganoff, F. K., Barrière, N. M., Boggs, S. E., Christensen, F. E., Craig, W. W., Grefenstette, B. W., Grindlay, J. E., Harrison, F. A., Hong, J., Madsen, K. K., Nynka, M., Stern, D., Tomsick, J. A., Wik, D. R., Zhang, S., Zhang, W. W., Zoglauer, A., “Extended hard-X-ray emission in the inner few parsecs of the Galaxy,” *Nature* 520, 646-649 (30 April 2015).
- [4] Schure K., Bell A., O’C Drury L. and Bykov A., “Diffusive shock acceleration and magnetic field amplification,” *SSR*, 173(1-4), 491-519 (07 Apr 2012).
- [5] Emslie, G., Dennis, B., Shih, A. Y., Chamberlin, P. C., Mewaldt, R. A., Moore, C. S., et al., “Global Energetics of Thirty-eight Large Solar Eruptive Events,” 759(1), 71 (2012). <http://doi.org/10.1088/0004-637X/759/1/71>
- [6] Lin, R. P., Dennis, B., Hurford, G., Smith, D. M., Zehnder, A., Harvey, P. R., et al., “The Reuven Ramaty High-Energy Solar Spectroscopic Imager (RHESSI),” *Solar Physics*, 210(1), 3–32 (2002). <http://doi.org/10.1023/A:1022428818870>
- [7] Hurford, et al., “The RHESSI Imaging Concept,” *Solar Physics*, Volume 210, *Issue 1-2*, pp 61-86 (Nov 2002).
- [8] Krucker, S., Hudson, H. S., Glesener, L. E., White, S. M., Masuda, S., Wuelser, J. P., & Lin, R. P., “Measurements of the coronal acceleration region of a solar flare,” *Astrophysical Journal*, (2) (2010) <http://doi.org/10.1088/0004-637X/714/2/1108>
- [10] Gaskin J. A., Apple, J., Chavis, K.S., Dietz, K., Holt, M., Koehler, H., Lis, T., O’Connor, B., Otero-Rodriguez, M., Pryor, J., Ramsey, B., Rinehart-Dawson, M., Smith, L., Sobey, A., Wilson-Hodge, C., Christe, S., Cramer, A., Edgerton, M., Rodriguez, M., Shih, A., Gregory, D., Jasper, J., Bohon, S., "High Energy Replicated Optics to Explore the Sun: Hard X-ray balloon-borne telescope," *IEEE Aerospace Conference*, 1-11 (2013).
- [11] Ramsey, B. D., Alexander, C. D., Apple, J. A., Benson, C. M., Dietz, K. L., Elsner, R. F., Engelhaupt, D. E., Ghosh, K. K., Kolodziejczak, J. J., O’Dell, S. L., Speegle, C. O., Swartz, D. A., Weisskopf, M. C., “First images from HERO, a hard X-ray focusing telescope,” *ApJ*, 568, 432-435 (2002).
- [12] Krucker, S., Christe, S., Glesener, L., Ishikawa, S., Ramsey, B., Gubarev, M., Saito, S., Takahashi, T., Watanabe, S., Tajima, H., Tanaka, T., Turin, P., Glaser, D., Fermin, J., Lin, R. P., “The focusing optics x-ray solar imager (FOXSI): instrument and first flight,” *Proc. SPIE 8862, Solar Physics and Space Weather Instrumentation V*, 88620R (September 26, 2013).
- [13] Krucker, S., Christe, S., Glesener, L., Ishikawa, McBride, S., Glaser, D., Turin, P., Lin, R. P., Gubarev, M., Ramsey, B., Saito, S., Tanaka, Y., Takahashi, T., Watanabe, S., Tanaka, T., Tajima, H., Masuda, S., “The Focusing Optics X-ray Solar Imager (FOXSI),” *Proc. SPIE 8147, Optics for EUV, X-Ray, and Gamma-Ray Astronomy V*, 814705 (October 03, 2011).
- [14] Krucker, S.; Christe, S.; Glesener, L.; Ishikawa, S.; Ramsey, B.; Takahashi, T.; Watanabe, S.; Saito, S.; Gubarev, M.; Kilaru, K.; Tajima, H.; Tanaka, T.; Turin, P.; McBride, S.; Glaser, D.; Fermin, J.; White, S.; Lin, R. P., *ApJ*, 2014, 10.1088/2041-8205/793/2/L321
- [15] Gaskin, J. A., Elsner, R. F., Ramsey, B. D., Wilson-Hodge, C. A., Tennant, A. F., Christe, S. D., Shih, A. Y., Kilaru, K., Swartz, D. A., Seller, P., Wilson, M. D., Stuchlik, D. W., Weddendorf, B., “SuperHERO: Design of a New Hard X-Ray Focusing Telescope,” *IEEE Aerospace Conf., Big Sky, MT* (2015).
- [16] <http://pcos.gsfc.nasa.gov/studies/x-ray-mission.php>
- [17] <http://www.nap.edu/catalog/13060/solar-and-space-physics-a-science-for-a-technological-society>
- [18] Gorenstein, P. “Focusing x-ray optics for astronomy,” *X-Ray Optics and Instrumentation*, 2010 (ID 109740), 19 pages (2010).

- [19] Koglin, J. E., Chen, H.C., Christensen, F. E., Chonko, J., Craig, W. W., Decker, T.R., Jimenez-Garate, M. A., Hailey, C. J., Harrison, F. A., Jensen, C. P., Sileo, M., Windt, D. L. and Yu, H., "Development of Precision Hard X-ray Multilayer Optics with Sub-Arcminute Performance," Proc. SPIE 4851, 673-683 (2003).
- [20] Kilaru, K., Ramsey, B. D., Gubarev, M. V., Gregory, D., "Differential deposition technique for figure corrections in grazing-incidence x-ray optics," *Opt. Eng.* 50(10), 106501 (September 28, 2011)
- [21] Ramsey, B. D. "(Fine-Pixel) imaging CdZnTe arrays for space applications." Nuclear Science Symposium Conference Record, 2001 IEEE. 4 (2001).
- [22] Gaskin, J.A., Christe, S. D., Elsner, R. F., Kilaru, K., Ramsey, B. D., Seller, P., Shih, A. Y., Stuchlik, D. W., Swartz, D. A., Tennant, A. F., Weddendorf, B., Wilson, M. D., Wilson-Hodge, C. A., "SuperHERO: the next generation hard x-ray HEROES telescope," Proc. SPIE 9144, Space Telescopes and Instrumentation 2014: Ultraviolet to Gamma Ray, 91443Z (July 25, 2014).
- [23] Jones, L., et al., 2009, NIM A, 604, 34-37
- [24] Seller et al., "Pixellated Cd(Zn)Te high-energy X-ray instrument, 9th international conference on position sensitive detectors," 12–16 September 2011, Aberystwyth, U.K.
- [25] M. Wilson et al, IEEE, TNS, 2015, Under Review
- [26] D. D. Duarte et al, Journal of Instrumentation, 8, 2013, P10018, doi:10.1088/1748-0221/8/10/P10018]
- [27] Veale et al, NIMA, 767, 2014, 218-226 doi:10.1016/j.nima.2014.08.036.
- [28] P. Seller et al, JINST, 6, 2011, C12009, doi:10.1088/1748-022/6/12/C12009.
- [29] TRL, see <https://www.nasa.gov/content/technology-readiness-level/>.