

Investigation of the Makeup, Source, and Removal Strategies for Total Organic Carbon in the Oxygen Generation System Recirculation Loop

Elizabeth M. Bowman, Ph.D.¹
The Boeing Company, Huntsville, AL, 35824

Joyce Carpenter²
Hamilton Sundstrand Space Systems International (HSSSI), A UTC Aerospace Systems Company, Windsor Locks, CT, 06096

Robert J. Roy³
Hamilton Sundstrand Corporation, A UTC Aerospace Systems Company, Windsor Locks, CT, 06096

Steve Van Keuren⁴
Anadarko Industries, L.L.C., Houston, TX, 77058

and
Mark E. Wilson⁵
The Boeing Company, Houston, TX, 77058

Since 2007, the Oxygen Generation System (OGS) on board the International Space Station (ISS) has been producing oxygen for crew respiration via water electrolysis. As water is consumed in the OGS recirculating water loop, make-up water is furnished by the ISS potable water bus. A rise in Total Organic Carbon (TOC) was observed beginning in February, 2011, which continues through the present date. Increasing TOC is of concern because the organic constituents responsible for the TOC were unknown and had not been identified; hence their impacts on the operation of the electrolytic cell stack components and on microorganism growth rates and types are unknown. Identification of the compounds responsible for the TOC increase, their sources, and estimates of their loadings in the OGA as well as possible mitigation strategies are presented.

Nomenclature

<i>ACTEX</i>	=	Activated Carbon/Ion Exchange
<i>CDRA</i>	=	Carbon Dioxide Reduction Assembly
<i>ISS</i>	=	International Space Station
<i>GC-MS</i>	=	Gas Chromatography-Mass Spectroscopy
<i>mg/L</i>	=	milligrams per liter
<i>µg/L</i>	=	micrograms per liter
<i>ppb</i>	=	parts per billion, equivalent to µg/L in dilute aqueous solutions

¹ Lead Chemist & Technical Lead Engineer, Boeing Huntsville Laboratories, Boeing Research & Technology, 499 Boeing Blvd. JN-06, Huntsville, AL 35824.

² Staff Engineer, Hamilton Sundstrand Space Systems International (HSSSI), A UTC Aerospace Systems Company, One Hamilton Road, M/S 1A-2-W66, Windsor Locks CT 06096.

³ Research Engineer, Hamilton Sundstrand Corporation, A UTC Aerospace Systems Company, One Hamilton Road, M/S 1A-2-W66, Windsor Locks, CT 06096

⁴ ECLS Systems SME, Anadarko Industries, L.L.C., 1322 Space Park Drive, Suite #A256, Houston, TX 77058

⁵ Associate Technical Fellow, Boeing Research & Technology, 13100 Space Center Blvd., MC HB3-20, Houston, TX 77059.

<i>ppm</i>	=	parts per million, equivalent to mg/L in dilute aqueous solutions
<i>OGA</i>	=	Oxygen Generation Assembly
<i>OGS</i>	=	Oxygen Generation System
<i>ORU</i>	=	Orbital Replaceable Unit
<i>RSA</i>	=	Rotary Separator Accumulator
<i>SA</i>	=	Sabatier Assembly
<i>TOC</i>	=	Total Organic Carbon
<i>UPA</i>	=	Urine Processor Assembly
<i>V</i>	=	Volts
<i>WPA</i>	=	Water Processor Assembly
<i>WRS</i>	=	Water Recovery System

I. Introduction

THE Oxygen Generation Assembly (OGA) located within the Oxygen Generation System (OGS) rack utilizes cathode feed water electrolysis to form oxygen and hydrogen gases. The oxygen is vented directly to the ISS cabin atmosphere for crew respiration while the hydrogen is sent along with carbon dioxide to the Sabatier Assembly (SA) through the Carbon Dioxide Reduction Assembly (CDRA) to make water to improve the overall water balance on the vehicle. When the Sabatier is unavailable, hydrogen is discarded overboard by through the external vent to space. On the ground, water electrolysis is a source of hydrogen which can be used, for example, as fuel for alternative energy vehicles. However, the energy required to drive water electrolysis is great enough that it is rarely used except for particular point of use applications, as there are cheaper alternative sources of hydrogen. In contrast, in the confined and remote atmosphere of ISS, the premium cost of delivering oxygen to station makes oxygen generation by water electrolysis an attractive option, even when hydrogen is vented overboard. The value of water electrolysis increased with the addition of the CDRA and SA to utilize hydrogen.

First operated to produce oxygen on ISS in July of 2007, the OGA was initially fed Shuttle fuel cell water from 10-liter bags through a pressurized accumulator bellows tank mounted on the OGS rack. In 2008, the Water Recovery System racks (WRS-1 and WRS-2) were installed and on-orbit, which include both the Urine Processor Assembly (UPA) and the Water Processor Assembly (WPA). The UPA extracts water from pretreated urine as urine distillate, which is combined with water condensate from the ISS air conditioners in a waste water accumulator. The WPA system purifies the waste water via adsorbent and resin based Multifiltration (MF) Beds, Particulate Filters and a Catalytic Reactor. Finally, recovered water is passed through an ion exchange resin bed which releases low levels of iodine to inhibit microbial growth, resulting in potable water for crew consumption, water for the Waste & Hygiene Compartment (WHC), and water for the OGA. Before entering the OGA, the potable water passes through an Inlet Deionizing Bed (Inlet DI Bed) ORU, which removes the iodine and coalesces entrained gas. If gas bubbles are detected by a gas sensor downstream, the feed water is shunted to the waste water bus, preventing any oxygen that may be present from mixing with the generated hydrogen. In the OGA, water is electrolyzed to yield oxygen and hydrogen gases in the Hydrogen Dome ORU, which contains the electrolysis cell stack, sensors, valves and a Rotary Separator Accumulator (RSA). The RSA separates the cathode (water) side product hydrogen gas from the water. Water is recirculated by the positive displacement Pump ORU through filters, an ACTEX-311 ion exchange bed, delta-pressure sensors, and a heat exchanger that sends waste heat to an ISS Internal Thermal Control System (ITCS) loop. The hydrogen dome provides multiple leakage barrier protection in the event of a failure. Figure 1 shows a simplified OGA diagram, including the water recirculation loop. As water is consumed, make up water is added batch-wise to the recirculation loop. The OGA was designed to operate with WPA potable water as a feed source. As of March 1, 2015, over 8275 pounds of oxygen (and over 1034 pounds of hydrogen) have been produced for crew on ISS.

During the operation of OGA on ISS, the recirculation loop water chemistry has experienced some changes, upsets, and recoveries. A previous reduction in pH and recovery to neutral pH has been described elsewhere^{1,2}. In early 2011, acidic byproducts from degradation of the cell stack membrane drove the recirculation loop pH well below neutral. Near neutral pH was recovered via ISS crew installation of a mixed resin deionizing bed (ACTEX-311) in the recirculation loop in May 2011. The ACTEX-311 removes the acidic byproducts of cell stack membrane degradation to keep the loop water pH near neutral which helps to minimize metallic corrosion and membrane degradation. Metallic corrosion products can jeopardize OGA operation by contaminating the cell membranes, which degrades water transport across the membranes. Although the feed water from the WPA has typically been below the nominal 3 ppm TOC limit (occasional excursions have been allowed), the the OGA recirculation loop water is currently experiencing a rise in measured Total Organic Carbon (TOC) as high as 19 ppm. The investigation and identification

of the TOC constituents, their possible effect on the OGA, and proposed remediation strategies are the subjects of this paper.

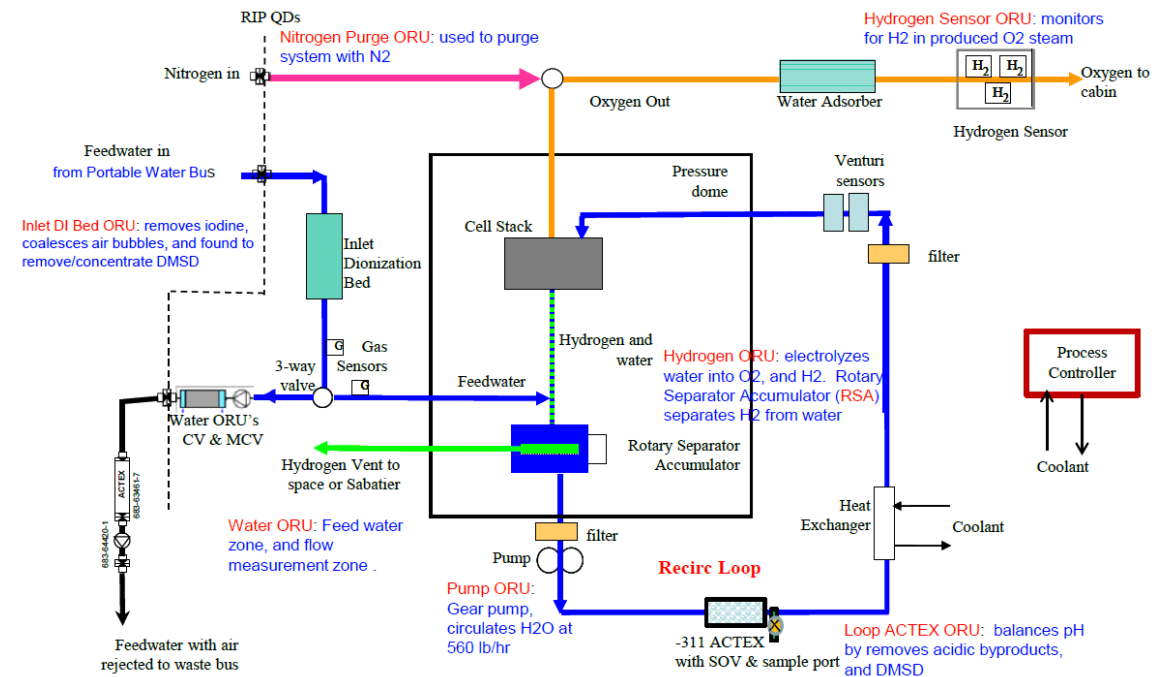

Figure 1. Simplified Oxygen Generation Assembly (OGA) diagram.

II. History of TOC in the OGS Recirculation Loop Water

TOC, as measured by a Dohrmann TOC Analyzer, is one of several measurements routinely performed on OGA recirculation loop samples periodically collected by crew and returned to ground for analysis. Sample volumes ranging from 45 mL to 120 mL volume are returned approximately every six months in Teflon® sample bags for chemical, particulate and microbial analyses. Analysis results help determine when TOC remediation should be implemented to avoid the risk of irreversible contamination damage to the OGA cell stack Membrane Electrode Assemblies (MEAs). Return-to-ground sample analysis also monitors recirculation loop pH to ensure the ACTEX-311 is still functioning properly, ensures no flow channel bypass, validates effective ion exchange, monitors non-ionic loading, and monitors microbial load and predominant species to quantify risk for biofouling in the recirculation loop components. Low but measurable TOC levels were first detected in a recirculation loop water sample in February of 2010. In July 2010 OGA Hydrogen Dome ORU's cell stack suffered a high voltage failure and was replaced using various contingency hoses and adapters to flush the remaining volume of the recirculation loop with clean deiodinated water to remove corrosion products and to restore the loop water to near neutral pH.

The TOC dropped below detectable limits in the October, 2010 due to the crew flush and replacement of the Hydrogen Dome ORU along with minimal OGA operation. Beginning with a sample in July, 2011, TOC levels increased beyond a few ppm. Additionally, an unusual peak shape in the TOC measurement was observed starting with samples from July, 2011. The peak shape varies in its extremity – that is, not all samples experience the same amount of tailing or deformation of the peak. The reason for the unusual peak shape was never identified, although many possibilities were considered and tested in the laboratory, including microbial detritus, dimethylsilanediol (DMSD), dimethylsulfone (DMSO₂), and large molecular weight molecules (dissolved or suspended polymers). One limitation of return to ground samples is volume, and it was speculated that there might be a small amount of a large molecular mass molecule present causing the unusual peak shape, but the limited sample volume (45 mL to 120 mL) made verification of this difficult. A plot of TOC as measured in the recirculation loop samples is shown in Figure 2.

Figure 2 also includes a timeline showing installation or removal and replacement of the ion exchange resin bed in the recirculation loop (ACTEX-311) and of the Multifiltration (MF) Beds in the WPA. The timeline includes the start and end of each observed TOC increase in the WPA product water to date.

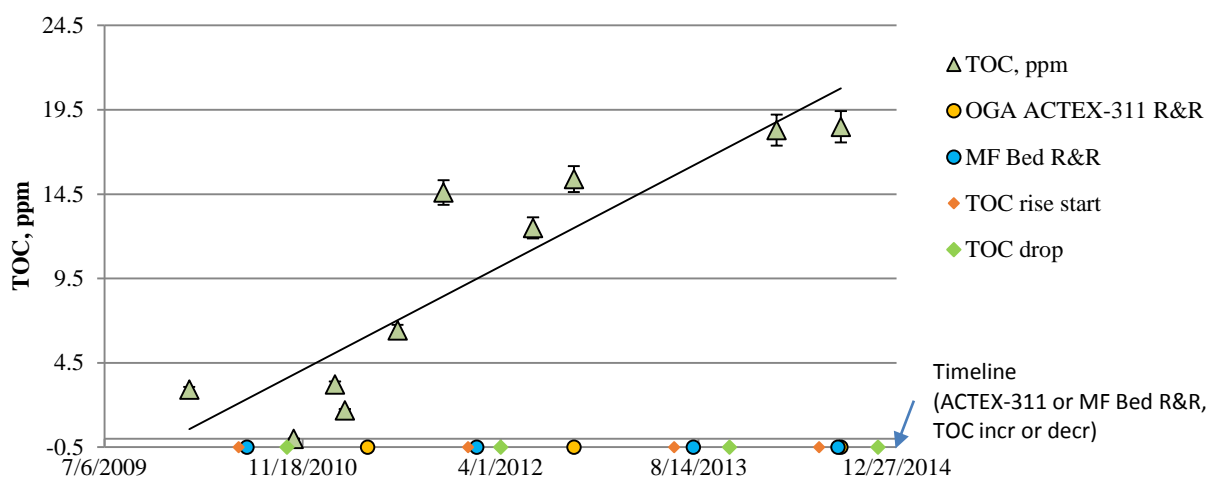

Figure 2. Plot of Total Organic Carbon measured in ppm for recirculation loop samples returned to ground with timeline for hardware install and replacement and for WPA TOC rise and drop.

III. Identification and Quantitation of TOC Constituents in the Recirculation Loop

A. Chemical Analysis of TOC Constituents in Returned to Ground Samples

Several possible sources of the increasing TOC in the OGA recirculation loop were considered. One early hypothesis was that the TOC in the OGA loop was caused by the same compound responsible for the TOC increase in the WPA product water (DMSD or dimethylsilanediol). However, the TOC in the OGA loop does not appear to have a correlation in time with the onset and resolution of TOC peaks from the WPA, the removal and replacement of MF Beds in the WPA, or the installation and removal and replacement of the ACTEX-311 in the OGA recirculation loop, as shown in Figure 2. Measurement of DMSD in the recirculation loop samples confirmed that the contribution to TOC by DMSD was low, typically accounting for only a few percent of the total TOC. Another question raised was whether the ACTEX-311 itself (an ion exchange bed) might be the source of TOC, especially since the samples from July, 2011, to October, 2012, showed an unusual TOC peak shape that is often associated with a large molecule that is difficult to chemically digest. However, the timing of TOC increases did not seem to correlate to ACTEX-311 installation or changeout. Additionally, the ACTEX-311 resin is used in a number of other applications on ISS without any evidence of organic leachate. (Although, in the closed OGA recirculation loop, there is arguably more potential for a buildup of low level contaminants as water is consumed by hydrolysis.) Early samples were also more volume limited (≤ 90 mL), making some exploratory tests more difficult to perform as most of the volume was consumed with other critical tests (particulates, ion chromatography, pH, conductivity, etc.)

The compound making up most of the TOC was identified as dimethylsulfone (DMSO₂, also known as methylsulfonylmethane, MSM, or sulfonylbis methane) via liquid-liquid extraction of the water samples followed by concentration and GC-MS analysis. Taking into account the rather large errors that can be associated with this method, agreement between predicted TOC based on the measured amount of DMSO₂ and measured TOC is reasonable (Figure 3). Additionally, a new measurement method was developed that allowed much better quantitation of DMSO₂, as shown in the final sample plotted in Figure 3. The measured concentrations of each compound and the calculated contributions to TOC are also tabulated in Table 1.

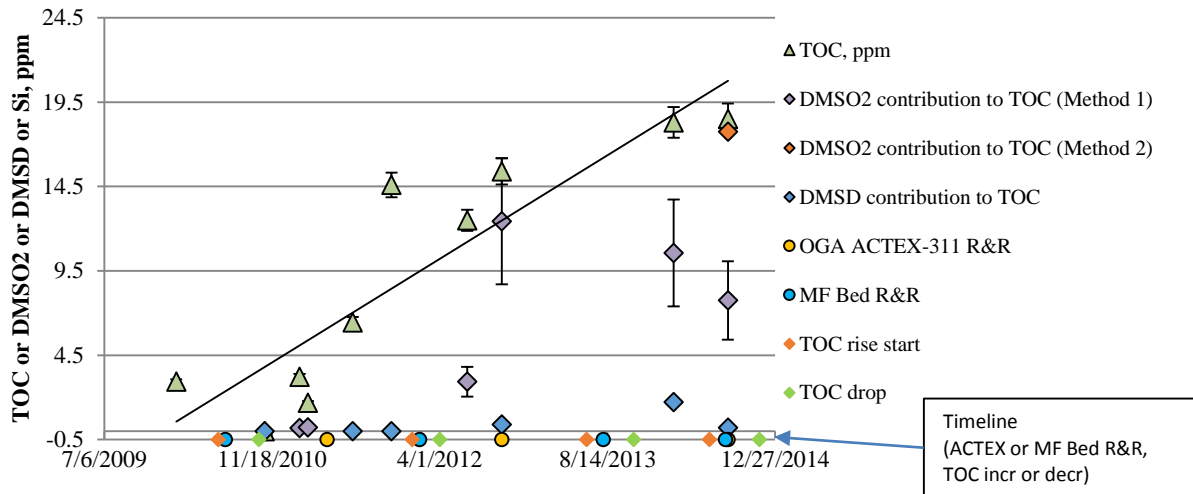

Figure 3. Measured TOC plotted with calculated contributions to TOC from measured DMSO₂ (two methods) and from measured DMSD.

Table 1. TOC and organic constituents data from return-to-ground samples from the OGS recirculation loop (shaded cells were not measured, typically due to sample volume restrictions). Includes calculated contribution to TOC for major constituents. The measured and calculated TOC values are plotted in Figure 3.

Date Collected	TOC, ppm	DMSO ₂ , ppm (Method 1)	DMSO ₂ contribution to TOC (Method 1)	DMSO ₂ , ppm (Method 2)	DMSO ₂ contribution to TOC (Method 2)	DMSD, ppm	DMSD contribution to TOC
2/5/2010	2.93			Prior to method development and implementation.			
10/27/2010	< 1.0					<LOD	0.000
2/8/2011	3.23	0.7	0.178				
3/5/2011	1.69	0.9	0.229				
7/16/2011	6.44					<LOD	0.000
11/9/2011	14.6					<LOD	0.000
6/22/2012	12.5	11.5	2.93				
10/3/2012	15.4	48.8	12.4			1.5	0.390
2/27/2014	18.3	41.4	10.6			6.6	1.72
8/8/2014	18.5	30.4	7.75		69.6	17.7	0.78

Note: add latest 2/4/2015 water sample results when available

B. Summary of Microbial Analysis of Returned to Ground Samples

Bacterial analysis results are shown in Figure 4 (enumeration) and in Table 1 (predominant organisms). Analysis for fungi is typically not performed on the OGS recirculation loop samples as historical data indicate fungi are unlikely to be present. In Figure 4, the hold time in days for each sample is also shown. Hold times are primarily due to on-orbit storage of samples before return. The return process is very efficient; typically chilled samples are delivered to the lab within 72 hours or so of return to ground. It is notable that neither the enumeration nor the predominant organisms for the sample with the longest hold time (177 days) stand out as unusual. This does not imply that hold time has no effect on the sample, however, as there may have been loss of biodiversity, for example (samples both before and after that sample yielded a larger number of organisms). *Ralsonia pickettii* remains a consistent, predominant organism throughout the sampling history. All organisms have also been isolated from other ISS systems, indicating that the OGA recirculation group does not harbor unique organisms. In terms of the topic of this

paper, the main concerns with microbial growth are the possibility of the compounds making up the TOC becoming a food source and any possible effect on the OGA system operation (primarily the electrolysis cell stack) of byproducts or breakdown products of the TOC compounds.

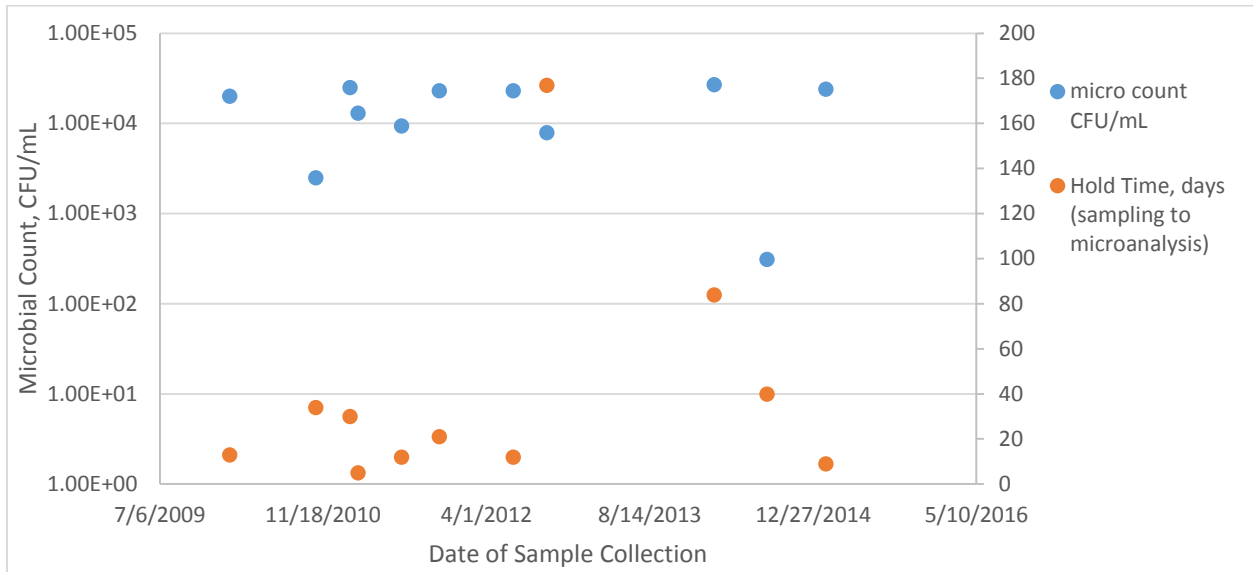

Figure 4. Bacterial counts in CFU/mL versus date of sample collection. Also shown in the hold time in days from sample collection to the date that microbial analysis was initiated.

Table 2. Predominant organisms isolated from OGS recirculation loop returned to ground water samples.

Date Collected	Julian Day	Return	Hold Time, days (sampling to microanalysis)	Enumeration CFU/mL	Predominant Organisms
2/5/2010	36	0	13	2.00E+04	<i>R. picketii</i>
10/27/2010	300	S23	34	2.50E+03	<i>R. picketii</i>
2/8/2011	39	0	30	2.50E+04	<i>R. picketii</i>
3/5/2011	64	0	5	1.30E+04	<i>R. picketii</i> , <i>Microbacterium sp</i>
7/16/2011	197	ULF 7	12	9.40E+03	<i>Microbacterium chocolateum</i> , <i>R. picketii</i>
11/9/2011	313	27S	21	2.30E+04	<i>R. picketii</i>
6/22/2012	158	S29	12	2.30E+04	<i>R. picketii</i> , <i>Acinetobacter baumannii</i> , <i>unidentified Flavobacterium</i>
10/3/2012	277	31S	177	7.90E+03	<i>R. picketii</i> , <i>unidentified Flavobacterium</i>
2/27/2014	58	SPX-3	84	2.70E+04	<i>R. picketii</i> , <i>unidentified Flavobacterium (2)</i> , <i>unidentified Phyllobacterium-like</i> , <i>Sphingomona yanoikuyae</i>
8/8/2014	220	38S	40	3.10E+02	<i>R. picketii</i>

Note: add latest 2/4/2015 water sample results when available

IV. TOC Sources and Risks

A. Dimethylsulfone Source and Risks

The most likely source for dimethylsulfone (DMSO₂) in the OGA recirculation loop is urine distillate from the Urine Processor Assembly (UPA). DMSO₂ is commonly found in urine and is a stable molecule. The human body passes DMSO₂ unchanged, and the closely related molecule dimethylsulfoxide (DMSO) is also oxidized to DMSO₂. Dimethylsulfone and dimethyl sulfoxide are naturally occurring components in many foods. Due in part to its inert nature and low affinity for many sorbents including those used in the WPA, DMSO₂ passes through the WPA at a relatively constant low concentration around 100 ppb, well below TOC limits for the water produced by the WPA. DMSO₂ also seems to persist relatively unchanged and unretained through the transport into the OGA and throughout the water electrolysis process. Consequently, as water is consumed to produce oxygen and replenished, the DMSO₂ remains in the recirculation loop, and its concentration slowly builds up over time. Estimates of expected DMSO₂ based on the amount of WPA water fed to the OGA and the average concentration of DMSO₂ based on analysis of returned to ground WPA product water samples agreed well, considering the necessity of estimating the concentration of DMSO₂ in the feed water to the OGA. This reinforces the suspicion that DMSO₂ passes through the WPA and OGS systems with little breakdown or removal on various sorbents and ion exchange beds.

As mentioned above, one potential risk in the build up of DMSO₂ is that it may become a nutrient source for microbial growth. And if DMSO₂ is consumed as a nutrient, the byproducts could potentially include reduced sulfur species (sulfides) that would be undesirable for cell stack operation as they could poison the catalyst in the OGA cell stack required for the electrolysis of water.

A second potential risk is the electrochemical reduction of DMSO₂ to generate reduced sulfur species. However, the cell stack is operated in such a way that the voltage available on the wet side of the stack should be near zero. Under these circumstances, it is unlikely that reduction of DMSO₂ will take place as it is a non-spontaneous process and would need to compete with the reduction of hydrogen ion to hydrogen gas, which takes place at around 0 V. Some similar (but larger) compounds require voltages greater than 0.5 V for reduction, and estimates for the reduction of dimethylsulfone itself range from +0.34 V to +0.7 V.³

A third potential risk with DMSO₂ is sorption into the polymer membranes in the electrolytic cell stack. It is unknown if or how this might affect cell stack function at these concentrations. If DMSO₂ were to diffuse into the polymer film, it would increase the likelihood of reduction to a potentially harmful reduced sulfur species. In general, the presence of TOC of any kind is undesirable for these kind of membrane systems.

While the authors and the OGA team acknowledges these risks, the stability of the DMSO₂ molecule and the fact that estimated DMSO₂ levels are close to measured DMSO₂ indicate that none of these processes are occurring to an appreciable degree. However, as the concentration of DMSO₂ rises, these risk levels increase. So it is prudent to develop and implement removal strategies.

B. Dimethylsilanediol Source and Risks

The other compound that has often been observed as a minor contributor to the TOC in the OGA recirculation loop is dimethylsilanediol (DMSD). DMSD is now understood to be a breakdown product of siloxanes introduced into the WPA from the Cabin Condensing Heat Exchangers (CCHX) located throughout ISS. It is notable that the concentration of DMSD has not shown a monotonic increase in the OGA recirculation loop.

DMSD was first observed in an OGA recirculation loop water sample collected in October of 2012. Ion exchange resins, and anion exchange resins in particular, have a low affinity to bind DMSD that can be easily overcome by any competing ions. As DMSD in the WPA product water is delivered to the OGA, it passes first through a relatively large Inlet Deionizing Bed (Inlet DI Bed), which was installed to prevent iodide from entering the OGA recirculation loop. DMSD may also be retained on this bed's mixed resin, and, if retained, it can be subsequently desorbed by anions such as iodide (present as a product of iodine added to disinfect drinking water) and bicarbonate (present as a result of CO₂ diffusion from ISS atmosphere through Regen ECLS Teflon[®] flex hoses into the water). It is relatively easy to estimate the maximum amount of iodide based on the known amount of iodine added. It is more difficult to estimate the amount of CO₂ present, as it is dependent on the flow rate (which affects the diffusion rate) and the kinetics of conversion from CO₂ to carbonic acid (Schwarzenbach, 2003)(conversion from carbonic acid, H₂CO₃, to bicarbonate ion, HCO₃⁻, is rapid). It is likely that any dissolved CO₂ (not converted to bicarbonate) in the OGA recirculation water is removed with the product hydrogen gas or permeates through cell stack membranes into the product oxygen gas at a combined rate competitive with its permeation in through the Regen ECLS flex hoses. Additionally, measured "capacity" of ion exchange resins for DMSD can be misleading because it binds very weakly and is easily desorbed, and the measured capacity in a laboratory setting is not consistent with what is observed on orbit. In practice, simply watching for the presence of DMSD in the recirculation loop is the best indicator that the

Inlet DI Bed mixed resin capacity for DMSD has been exceeded. For the currently installed Inlet DI Bed, this happened sometime between November, 2011, and October, 2012, when DMSD was first observed in the recirculation loop sample returned to ground for analysis.

Subsequent OGA recirculation loop water samples have shown small increases and decreases in DMSD concentration. One possible explanation is the change out of the ACTEX-311 ion exchange resin bed approximately every two years, which, like the much larger Inlet DI Bed, can reversibly absorb DMSD. Installation of a new ACTEX-311 would be expected to take up DMSD and then release it again as other ions (fluoride and bicarbonate are the most likely anions) are picked up by the ion exchange resin. The ACTEX-311 is a mixed ion exchange bed, so cations are also taken up, but the adsorption and desorption of DMSD seems to be primarily a function of anion exchange resins. Effects of pH, cations, temperature, etc. on the retention of DMSD by the mixed resin in either the Inlet DI Bed or the ACTEX-311 have not been specifically studied. Again, in practice, presence of DMSD indicates breakthrough of DMSD for that particular system.

The risks presented by DMSD, in contrast to those for DMSO_2 (most of which include the risk for catalyst poisoning), are related to the possibility of DMSD adhering to surfaces and/or recombining to form larger siloxane molecules which could inhibit the transport of water from the bulk recirculation water loop to the membrane surfaces of the water electrolysis cell stack.

C. Monitoring OGS Function for Early Indication of Failures

After identification of the TOC constituents and their possible risks, it was desirable to better understand and quantify those risks. Consequently, testing on the ground for deleterious effects of DMSD and DMSO_2 was considered. However, developing an appropriate test setup to accurately model materials and the microgravity environment on ISS proved difficult. An alternative approach was taken to monitor the health of the on-orbit system.

One way to monitor the function of the OGS is via chemical and microbial analysis of the return-to-ground samples, as outlined above. Several parameters such as pH and ion content are monitored in addition to the level of TOC and TOC constituents. As described above, evaluating the history of these measurements and comparing to estimated values where possible (as well as to analysis results for WPA product water samples) gives a good picture of the recirculation loop health at the time of sampling. However, these samples are only collected every six months, at best.

Another indicator of the health of the OGA are periodic cell stack polarization scans, and this can be done much more quickly if needed since receipt of the data does not rely on a return-to-ground sample and is accomplished by ground command. The cell stack polarization scan automatically increases the current density to the cell stack membranes during oxygen production. A plot of the corresponding voltage at the highest production rates is evaluated for any curve shifts, which can indicate contamination within the cell stack membranes and / or catalyst. By evaluating the voltage during a polarization scan of the cell stack and comparing to historical data, the health of the cell stack and the OGS can be monitored. Changes such as cation contamination in the cell stack membranes produce characteristic changes in the polarization scan. Cationic contamination of the cell stack is detrimental as it results in a loss of cell membrane ion exchange sites and a reduction in membrane water content (both of which result in increased resistance to proton transfer), and reduction in water permeability, which results in reduced water transport from the cathode feed water to the anode where electrolysis is initiated.

Together, the analysis of return to ground samples and cell stack polarization scans provide a good, periodic picture of the functioning health of the OGA.

V. Remediation Strategies

Remediation strategies can be targeted at the specific TOC constituents (e.g. adsorbents) or general in nature.

To remove the specific constituents (DMSD and DMSO_2), two different approaches are likely needed. DMSO_2 builds up in the OGA recirculation loop precisely because it is poorly retained and chemically stable. None of the adsorbents currently used on orbit were very effective at removing DMSO_2 . Fortunately, during candidate adsorbent testing for better removal of DMSD and siloxanes and for use in the WPA MF Beds, a particular adsorbent (Ambersorb® 4652) was identified as having both excellent capacity and irreversible binding for DMSO_2 . This adsorbent linearly removed over 85% of DMSO_2 from an aqueous test solution containing up to 600 ppm DMSO_2 , well above current levels in the recirculation loop.⁴ Although there was understanding that the primary constituent of the TOC in the recirculation loop was indeed DMSO_2 , there was no feasible way to remove the DMSO_2 from the loop

water prior to the identification of this adsorbent. Current work is underway to analyze the resin from an expended and returned OGA loop ACTEX-311 to determine remaining ion exchange capacity and DMSD loading at the Boeing laboratories in Huntsville, AL. Based on the remaining capacity, a fraction of the mixed resin in the ACTEX-311 cartridge may be replaced with the new adsorbent and the new ACTEX version submitted for flight certification and installation in the OGA recirculation loop for DMSO₂ removal.

Removal of DMSD is partially accomplished by the ion exchange resins currently used in the Inlet DI Bed and the ACTEX-311, as described above. But the ultimate remediation strategy for DMSD is to prevent its formation much further upstream. As has been discussed elsewhere, DMSD is generated in the breakdown of siloxanes in the CCHX and WPA systems. Removal of siloxanes from the air, before they get to these systems, is far superior to attempting to remove DMSD downstream in the WPA and the OGA. This development activity is currently in work at Boeing and NASA. In the interim, the ACTEX-311 and, to some extent, the Inlet DI Bed, provide partial protection for the OGA from the buildup of DMSD within the recirculation loop. Additionally, the Ambersorb[®] 4652 has limited affinity for irreversible binding of DMSD, and residual DMSD or DMSD that persists after air scrubbing may be removed from the loop with the next version of ACTEX.

More general remediation strategies include “bleed and feed” and recirculation loop scrubbing. In principle, these differ primarily in degree and speed. The current OGS and OGA designs do not provide for easy replacement of water in the recirculation loop and may risk high water quantities within the OGA RSA, which can prevent OGA reactivation. Given that ECLS systems include complex chemical recycling systems with many opportunities for the collection or concentration of even low level constituents, including a ground commandable, automated water flush or refresh capability with bypass to the waste water bus in future systems would be prudent.

Bleed and feed is a process by which this small amount of water is removed (bleed) from the recirculation loop as new water is added (feed) over some period of time. From a practical standpoint, any on orbit bleed and feed activity must be accomplished with as little crew time and as little upset to the crew activities and cabin environment as possible. Ground test of an on-orbit capable, front of the OGS rack mounted effluent bag with flex hoses, a throttle valve and adapters (all parts are currently on-orbit except for one small adapter), which will allow for crew to setup a 1 L/hr maximum bleed off of the recirculation loop water while OGA is in Standby producing a small amount of oxygen. This bleed procedure will safely remove approximately 80% of contaminants from the recirculation loop over a 40 hour period without creating any safety hazards or risking too much RSA water quantity. Crew can continue to exercise within Node 3 since the OGS rack doors are closed and the effluent bag is located in a unobstructed area of the cabin. By providing a single adapter and water line to an available water container, it is possible to accomplish a rather thorough bleed and feed over a couple of days that will replace the water in the recirculation loop without requiring any major repositioning of OGS hardware and while still allowing normal operations in the vicinity of the OGS rack. A ground test of this procedure is scheduled for March 2015 to establish reproducible maximum bleed flow rates and measure throughput flow rate and pressure, after which it will be available for use on orbit.

A complete “scrub” of the recirculation loop would occur when the entire volume is flushed or replaced. A partial scrub occurred during replacement of the Hydrogen Dome ORU in July, 2010. This is a rare occurrence and not a desirable approach to mitigate TOC on orbit as the current OGS was not designed for periodic loop flushing.

VI. Conclusion

Since July 2007, the OGS on board the ISS has been producing oxygen for crew respiration via water electrolysis. As water is consumed and makeup water is supplied by the ISS potable water bus, two compounds have contributed to a rise in the TOC concentration beginning in February, 2011. Two TOC constituents were identified. Dimethylsulfone, or DMSO₂, is introduced with urine distillate, passed at low concentration through the WPA, and subsequently concentrates in the dead end of the OGA recirculation loop. Dimethylsilanediol, or DMSD, is a product of the breakdown of siloxanes and is passed periodically through the WPA to the potable water bus supplying feedwater to the OGA. The potential risks of both of these TOC compounds has been considered, and the OGA is monitored on-orbit for any changes in performance so that any degradation in performance can be identified as early as possible. Three primary remediation strategies were discussed, two of which are targeted at the specific compounds identified, and one of which can be applied to the build up of any contaminant in the recirculation loop. Ideally, future systems would incorporate some method for monitoring and periodically replacing the water in a recirculation loop to avoid the build up of any chemical or microbial constituent.

Acknowledgments

The authors wish to acknowledge the excellent work by Eric Cramblit, Natalee Weir, and Danielle Bowman of Boeing. This work was accomplished by NASA and Boeing and its subcontractors under the International Space Station contract NAS15-10000.

References

¹Carpenter, J., Gentry, G., Diderich, G., Roy, R., Golden, J., VanKeuren, S., Steele, J., Rector, T., Varsik, J., Montefusco, D., Cole, H., Wilson, M., and Worthy, E. S., "Investigation into the High-Voltage Shutdown of the Oxygen Generation System Aboard the International Space Station," 42nd International Conference on Environmental Systems, AIAA, San Diego, CA, AIAA 2012-3613.

²VanKeuren, S., Ghariani, A., et al, "Advancing the Oxygen Generation Assembly Design to Increase Reliability and Reduce Costs for a Future Long Duration Mission," 45th International Conference on Environmental Systems, Bellevue, WA, 2015.

³Schwarzenbach, R. P., Gschwend, P. M., Imboden, D. M. *Environmental Organic Chemistry*, 2nd ed., John Wiley & Sons, Hoboken, New Jersey, 2003, Chap. 14.

⁴Rector, T., Metselaar, C., Peyton, B., Steele, J., Michalek, W., Bowman, E., Wilson, M., Gazda, D., and Carter, D. L., "An Evaluation of Technology to Remove Problematic Organic Compounds from the International Space Station Potable Water," 44th International Conference on Environmental Systems, Tucson, AZ, 2014, Paper Number 135.