

Update on Advection-Diffusion Purge Flow Model

Thermal & Fluids Analysis Workshop

August 3-7, 2015

DoubleTree Hotel, Silver Spring, MD

Lubos Brieda

Particle In Cell Consulting LLC



What is purge?

- Purging is the process of continuously flowing clean gas into a sensitive electronic or optical equipment to maintain internal cleanliness
 - Typically Grade B or Grade C gaseous nitrogen is used
- Common on spacecraft instruments:
 - Used on MMS and GOES-R missions
 - Both missions utilize microchannel plates (FPI on MMS and MPS-LO on GOES-R), highly sensitive to molecular contamination
 - GOES-R also contains UV (SUVI) and optical (ABI and GLM) instruments which are also sensitive to molecular contamination
- The working assumption is gas flow “volume exchanges” clean up internal environment, and that positive pressure prevents infiltration of ambient environment
- Purge is also assumed to prevent infiltration of “dust” particulates

Impact on Design and I&T

- There are also drawbacks to purging:
 - Purge ports must be added to instruments
 - Flight-ready purge plumbing must be installed on the spacecraft if T-0 purge used
 - Purge can be a contaminant source if not designed right
 - Purge carts must be designed and built – often a non-trivial exercise due to use of high-pressure K-bottles
 - Analysis is required to determine necessary purge flow rates and time-off purge
 - Time off purge can become a driving factor in I&T activities
- Purge can also sometimes lead to false sense of security
 - Due to complex internal multi-cavity geometry, purge gas may flow out of the device without passing over the sensitive component

What purge flow rate is needed and how much time off purge can an instrument tolerate?

Analytical Model

- Scialdone introduced a simple model in “Preventing Molecular and Particulate Infiltration in Confined Volume”, *SPIE 2784*, 1999.

- Follow up to 1978 NASA TP-1172, “Water-Vapor Pressure in C.V.”

- Start with mass conservation law

$$V \frac{dP}{dt} = C(P_0 - P) - Q(P - P_u)$$

- Can be obtained from $\frac{\partial \rho}{\partial t} + \nabla \cdot \vec{u} = 0$ assuming $\frac{dT}{dt} = 0$

- Integrate using integration factor to yield

$$P = k \exp\left[-\frac{C + Q}{V} t\right] + \frac{CP_0 + QP_u}{C + Q}$$

- Where k is found from $P(0) = P_i$

$$P = \left[\frac{C(P_i - P_0) + Q(P_i - P_u)}{C + Q} \right] \exp\left(-\frac{C + Q}{V} t\right) + \frac{CP_0 + QP_u}{C + Q}$$

- If $Q = 0$ (no purge) and $P_u = 0$ (clean gas), the above reduces to

$$P = (P_i - P_0) \exp\left(-\frac{C}{V} t\right) + P_0$$

- Scialdone also experimentally studied the aperture conductance and found that

$$\tau_v \equiv \frac{V}{C} = 0.42 * 24 * \left(\frac{V}{A}\right) \text{ (but doesn't agree with graph)}$$

P (internal partial pressure of contaminant)

P_0 ambient pressure of contaminant

C conductance through aperture

Q flow rate of purge gas

Research Objectives

- Scialdone's model is easy to use but:
 - The model is 0D, does not take into account details of internal geometry
 - Pressure differential or total pressure not used
 - C/V ratio applicable only to thin apertures
- The objective of this study is to investigate the simple model in more detail:
 - It seems too simple to be true. But maybe it is?

**Simple models can be used by engineers to quickly obtain answers.
On the other hand, they can result in false findings or an overly simplified
model**

Research Summary

- Performed a combined experimental and numerical effort to investigate purging in more detail: **SPIE-2014**
- A cylindrical enclosure purged with GN2
 - Instrumented with multiple miniature humidity and pressure sensors
 - Included internal flow obstructions
 - Axial symmetry desired in order to allow RZ simulation
- Sensors used to measure rate of water infiltration after purge was stopped
- Numerical tools developed to simulate evolution of contaminant density with or without gas flow
 - Combined **advection/diffusion** and **incompressible Navier Stokes** solver
- Main topics:
 1. Spatial and temporal variation
 2. Geometry impact (vortices, future work)
 3. Impact on particulates

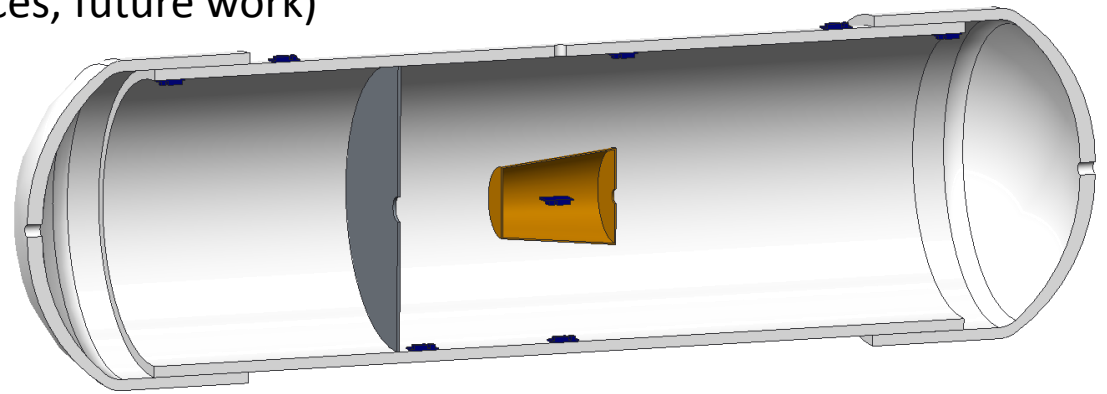

PART I: EXPERIMENTAL EFFORT

Experimental Setup

- Experiment consisted of a size 10 PVC pipe capped on both ends with size 10 end caps, 3.3 feet long
- 0.43" diameter holes were drilled in the center of both end caps
 - One was connected to a purge system, consisting of a pressure regulator, and a flow meter
 - The other was left open to the atmosphere
- Purge gas was provided by Grade C K bottle or by using a boil-off dewer house gas
- Testing was performed at GSFC propulsion lab



Internal Setup

- Performed series of tests:
 - Empty internal cavity with 2scfh (~1L/min), 4scfh (~2L/min), and 1scfh (~0.5 L/min)
 - Baffle @ 2scfh
 - Secondary volume @ 2scfh
- Baffle constructed from ESD bagging
- Internal volume constructed by wrapping a coffee cup in foil

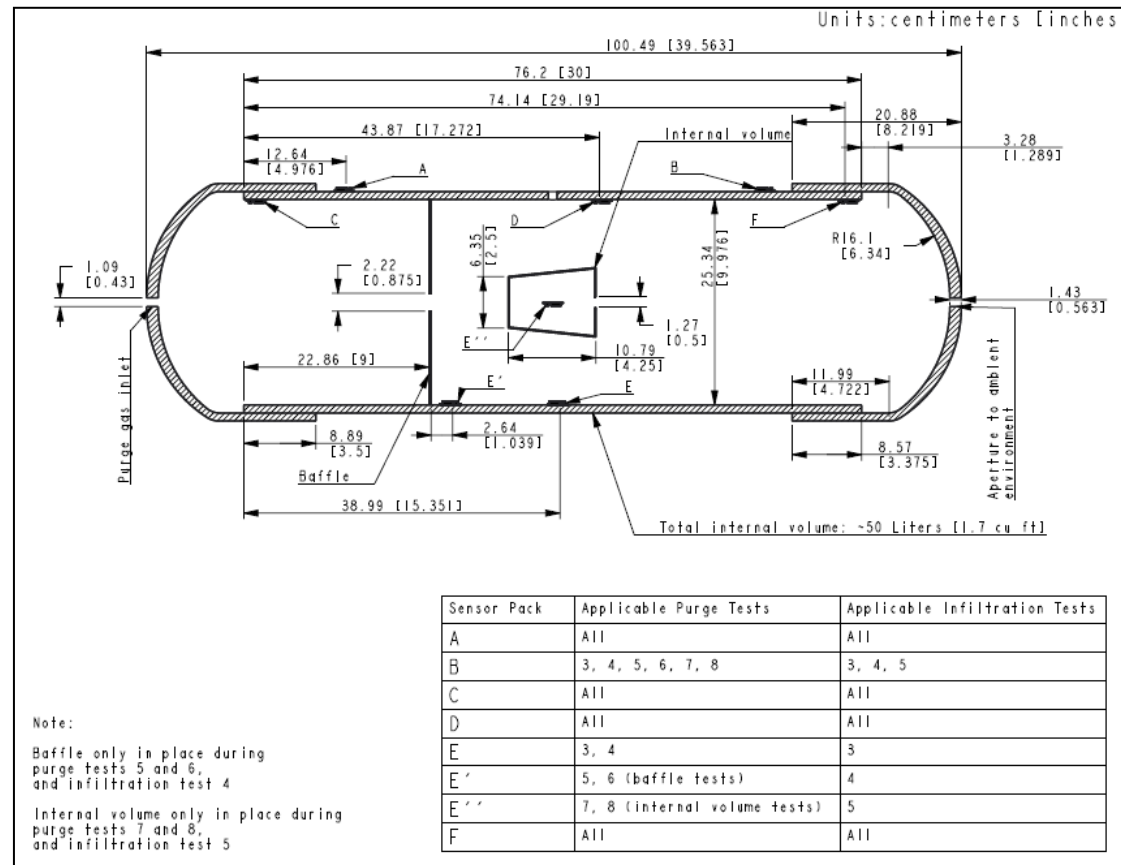

Sensors and Data Acquisition

- Used Arduino Mega for a data collection
- Sensors:
 - Honeywell HIH-5030 capacitive relative humidity sensor capable of measuring from 0 to 100% RH
 - Freescale Semiconductor MPXHZ6130A piezoresistive transducer with analog ratiometric output used to measure absolute pressure
 - Analog TMP36 sensor used to measure temperature
- Sensors mounted on a breakout board connected to a harness
- Typically six sensors were used: four internal, two external
- Java program to sample sensors every 10 seconds

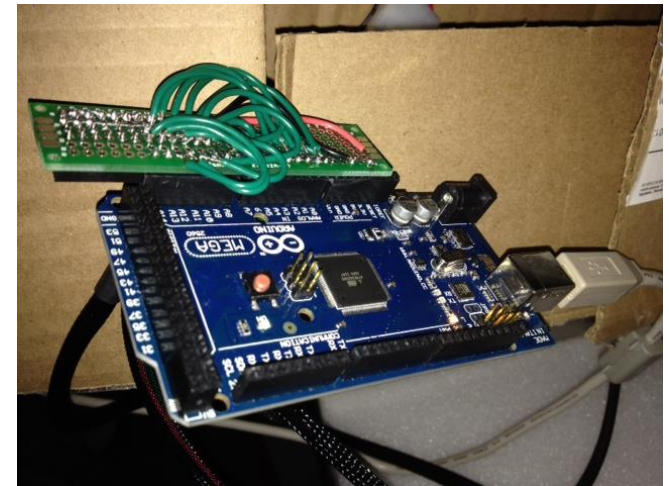

Typical Results (2 L/min)

- Negligible variation in internal humidity for empty cavity

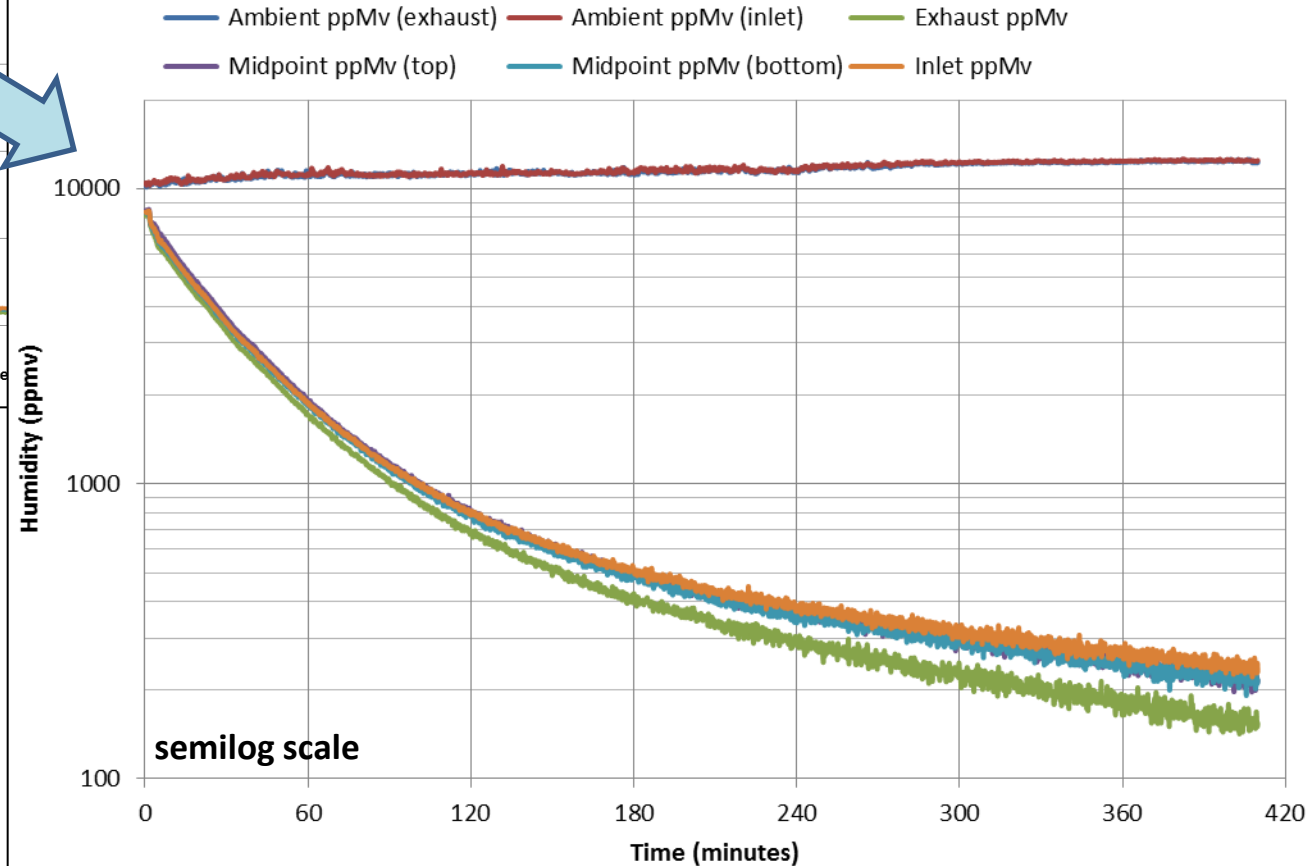
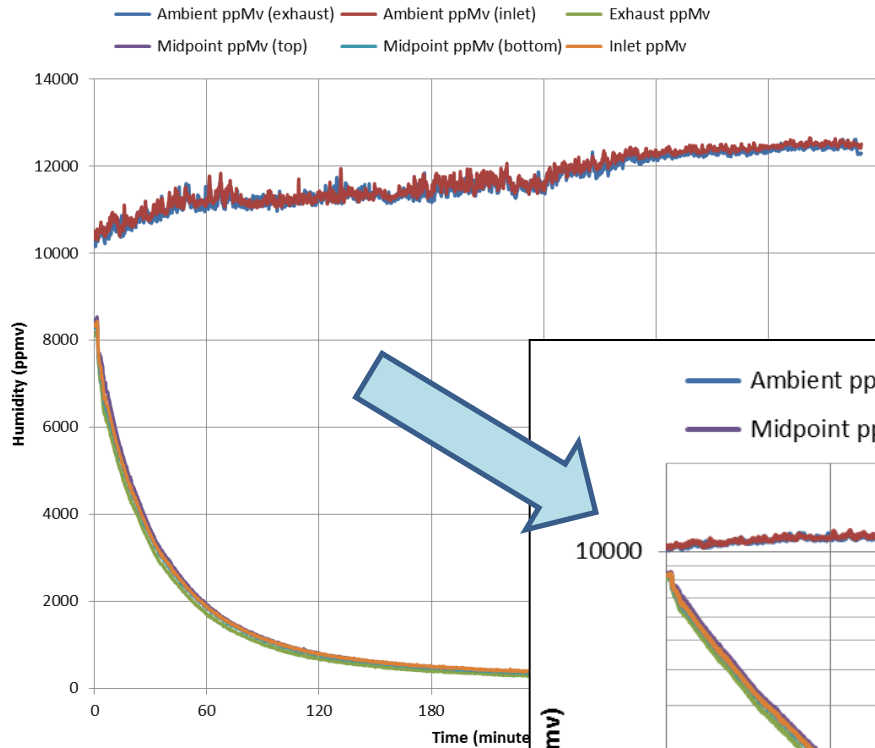

Temperature and Pressure

- No impact on pressure or temperature from purge activation

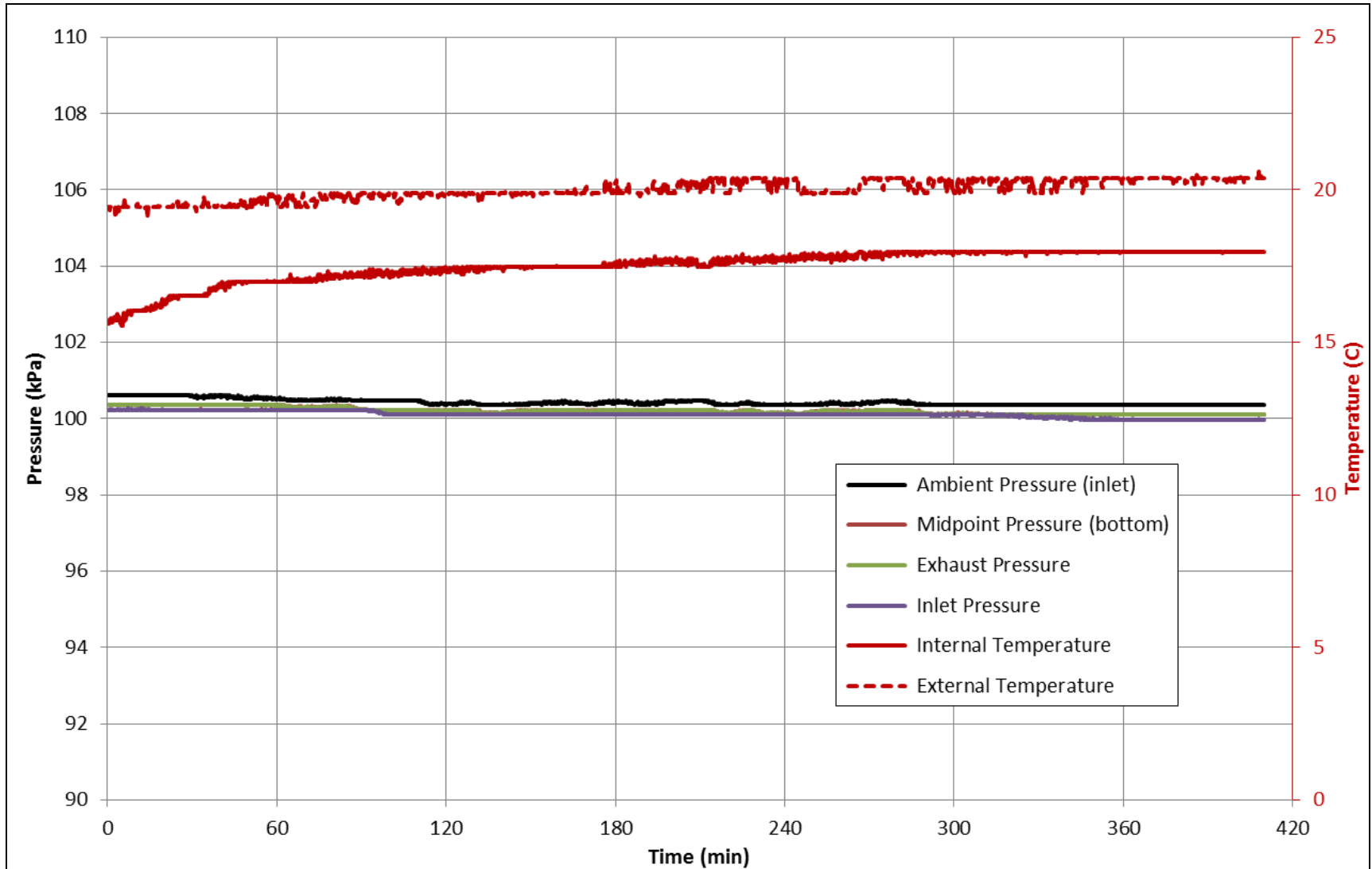

Comparison with Model

1. Double exponential results in better fit than a single exponential
2. Significant difference with known values for Q, V, and C
3. Concentration continues to drop while model predicts asymptotic behavior

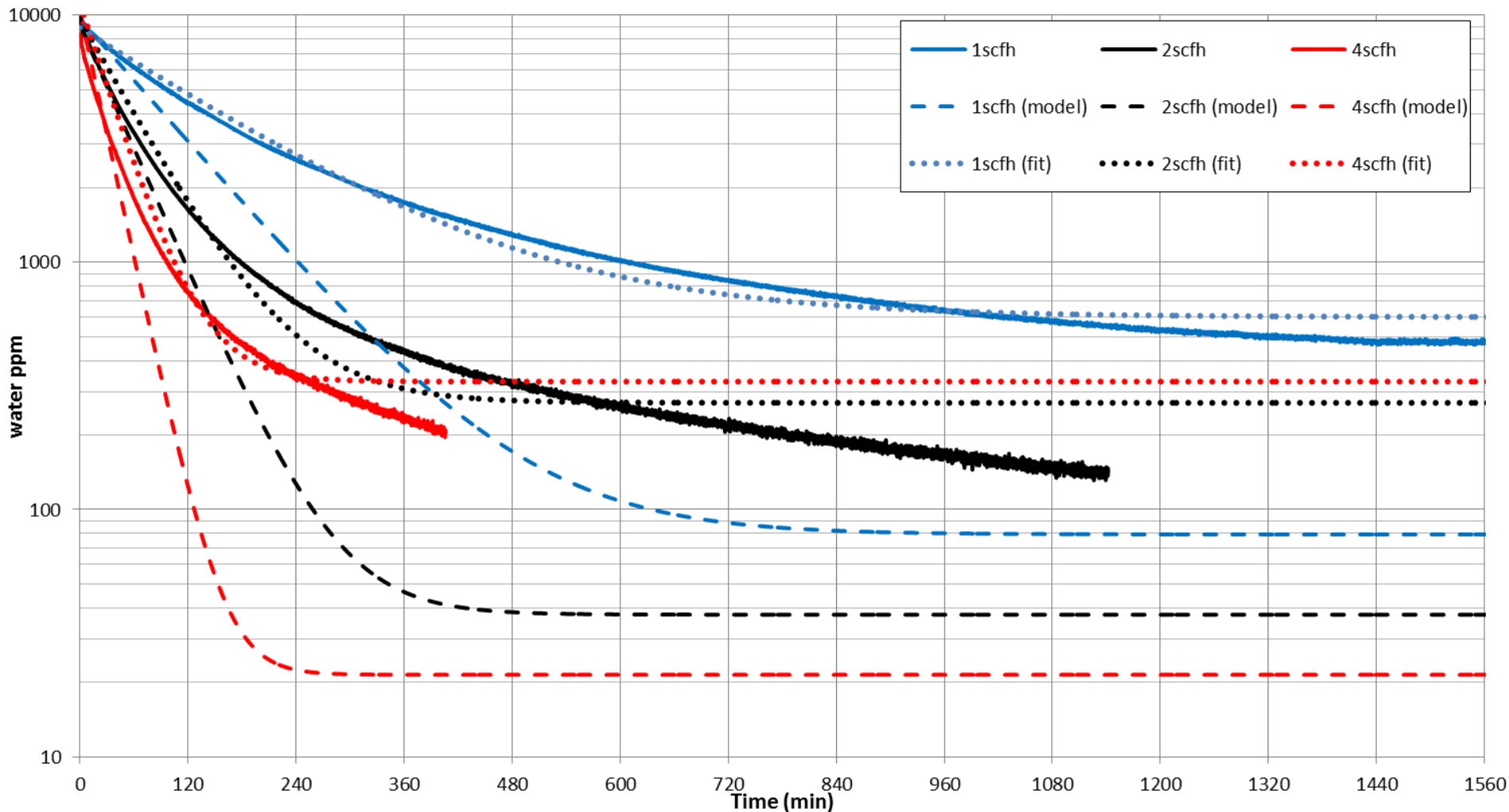

Internal Variation

- Adding internal obstacles results in a non-uniform internal concentration

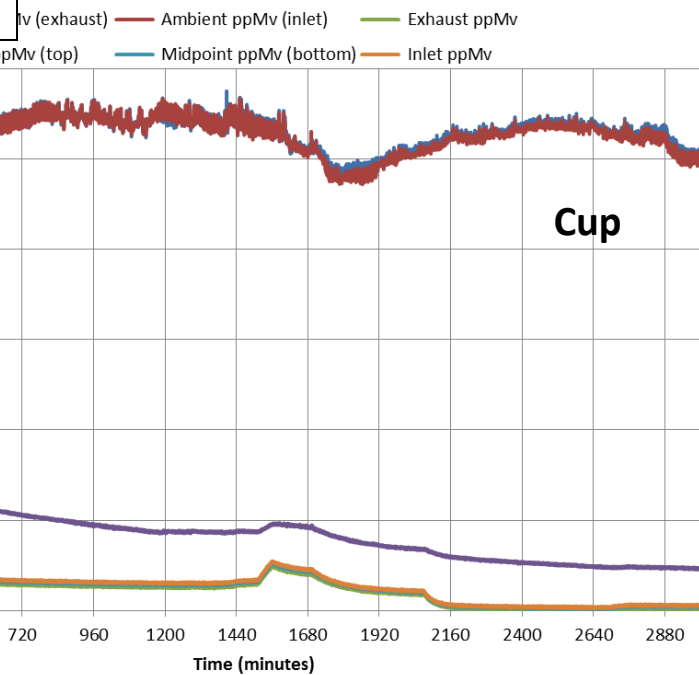
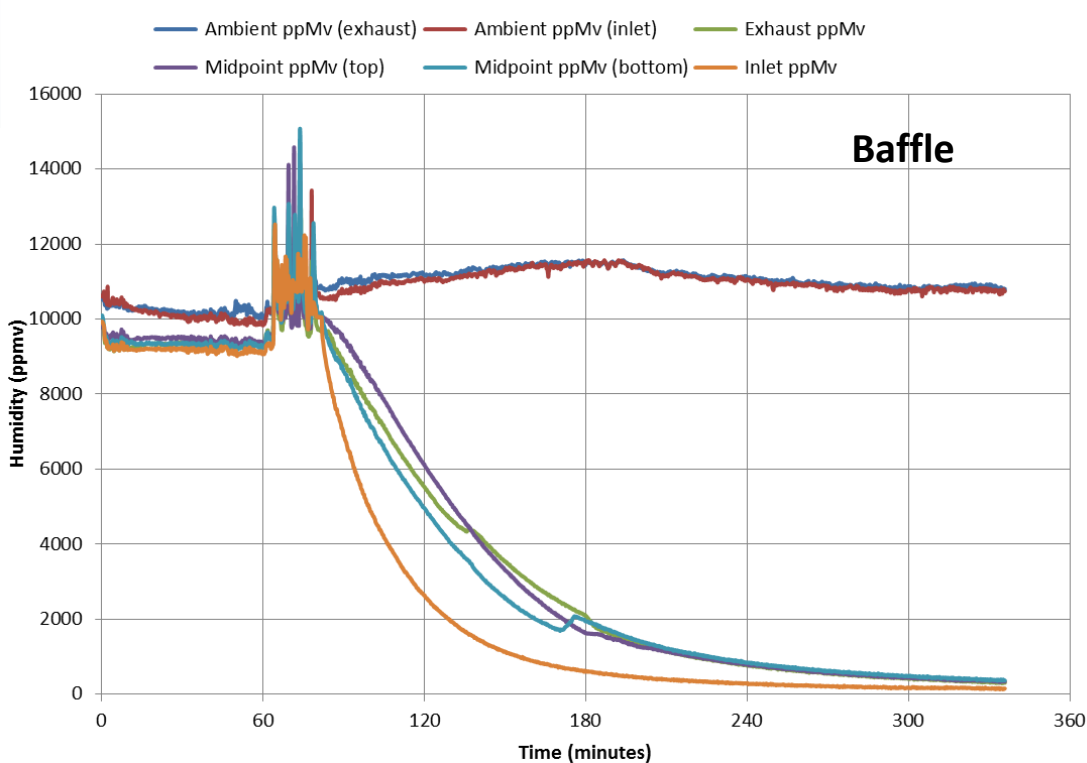

Water Infiltration

- After the completion of each purge run, flow was stopped, and water was allowed to diffuse back into the cavity
- Plots below shows typical response
 - Internal humidity leveled off at approximately 75% of external value after 6 days – **thick orifice effect**
 - Internal sensors reached ambient values when cap was removed

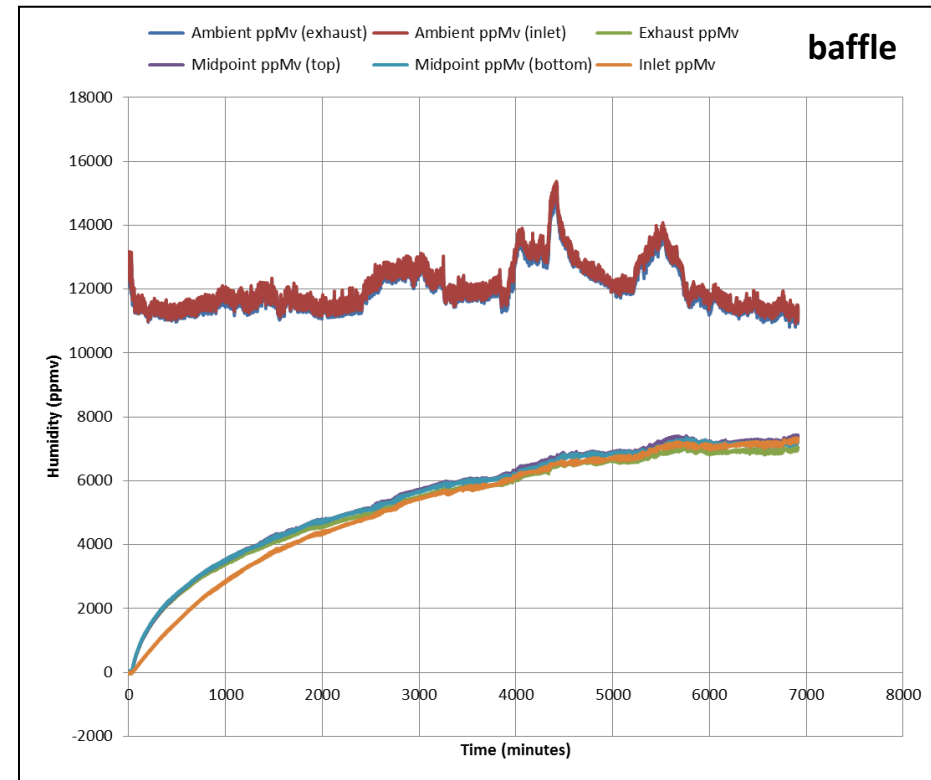
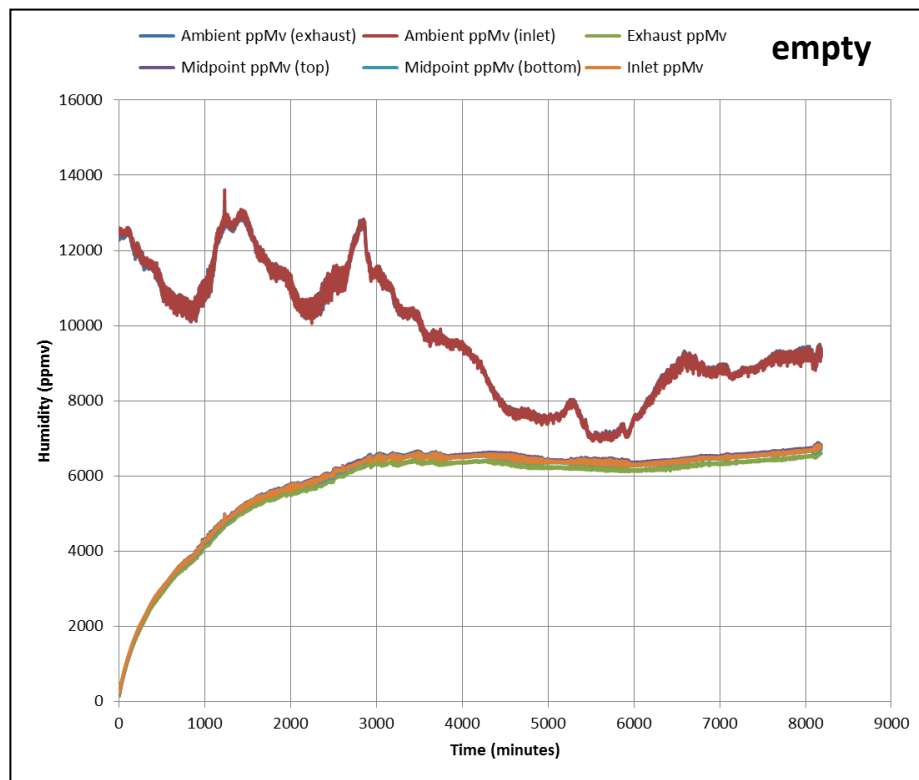

PART II: NUMERICAL MODEL

Numerical Model

- Java code developed to study flow in more details
- Advection-diffusion equation for water density

$$\frac{\partial n_w}{\partial t} + \nabla \cdot (-D\nabla n_w + \vec{u}n_w) = R$$

- Incompressible Navier Stokes solver to obtain gas velocity

$$\left(\frac{\partial \vec{u}}{\partial t} + \vec{u}\nabla \cdot \vec{u} \right) = -\frac{1}{\rho} \nabla p + \frac{\mu}{\rho} (\nabla^2 \vec{u})$$

- Solution strategy:
 - Integrate NS equations, independent of water density
 - Use new velocity field to update water density
- Implied assumptions:
 - Water density has no impact on flow solution
 - The only source of water is the ambient environment (for now...)
 - Turbulence not modeled (also for now)

Advection Diffusion Solver

- Solution obtained on a staggered grid:
 - Water density known at cell centers
 - Velocity known at centroids of cell edges
- Assumed axial symmetry, results in an axisymmetric (RZ) code
- No flux through walls implies $(D\nabla n_w + n_w \vec{u}_w) \cdot \hat{n} = 0$ along boundaries
 - Also true along axis of rotation, $r = 0$
- Sugar-cubing used to mark solid cells
- Ambient density varied based on experimental data

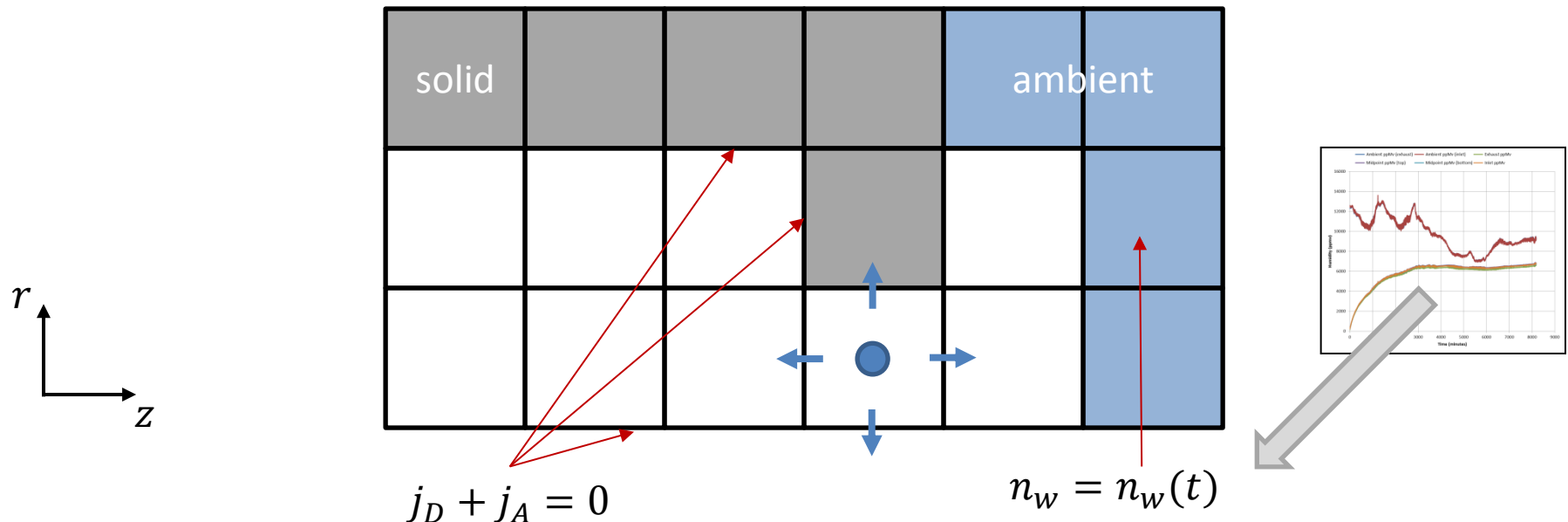

Incompressible NS Solver

- Solved using projection method. Velocity integration split to part due to advection/viscosity, and to part due to pressure

$$\frac{\vec{u}^t - \vec{u}^k}{\Delta t} = -\vec{u}\nabla \cdot \vec{u} + \nu(\nabla^2\vec{u})$$

$$\frac{\vec{u}^{k+1} - \vec{u}^t}{\Delta t} = -\frac{1}{\rho}\nabla p$$

- “Temporary” velocity found from $\vec{u}^t = \vec{u}^k - \Delta t(\vec{u}\nabla \cdot \vec{u} + \nu\nabla^2\vec{u})$
- Mass conservation $\nabla \cdot \vec{u}^{k+1} = 0$ used in equation 2 to obtain for pressure

$$\nabla^2 p = \frac{\rho}{\Delta t} \nabla \cdot \vec{u}^t$$

- New velocity then found from

$$\vec{u}^{k+1} = \vec{u}^t - \frac{\Delta t}{\rho} \nabla p$$

- Same grid as AD solver
 - Pressure at centers, velocity at edges
 - Guard cells used to set tangential velocity
- No slip condition used on solid faces
 - $\partial u / \partial n = 0$ used on open face
- Forward difference for time integration

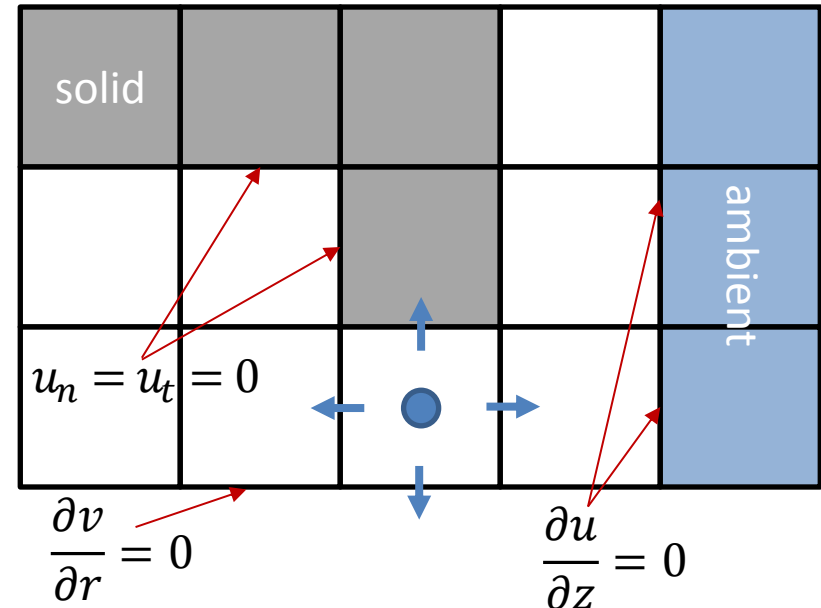

Water Infiltration (Diffusion only)

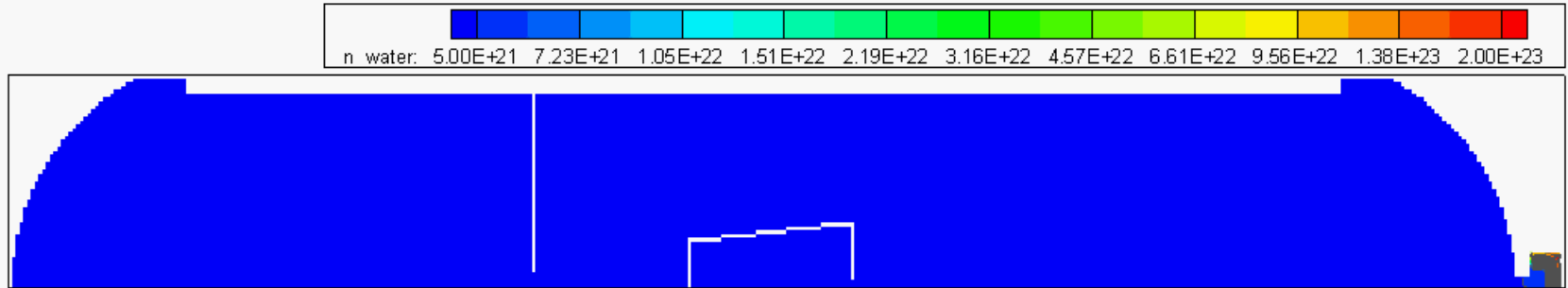

- Above animation shows water infiltration for a hypothetical test with both the baffle and the internal volume
- Plot on right is a close up of the aperture
 - Highlights typical concentration gradient
 - Also shown is the mesh resolution
- Diffusion-only cases took several hours on a workstation
 - Advection required much smaller steps to retain convergence

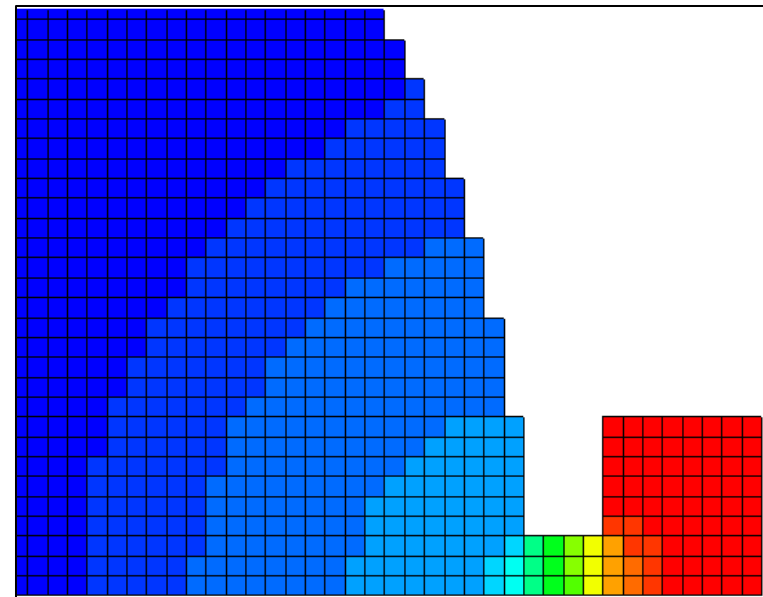

Comparison with Experiment

- Used virtual sensors to collect pressure and humidity

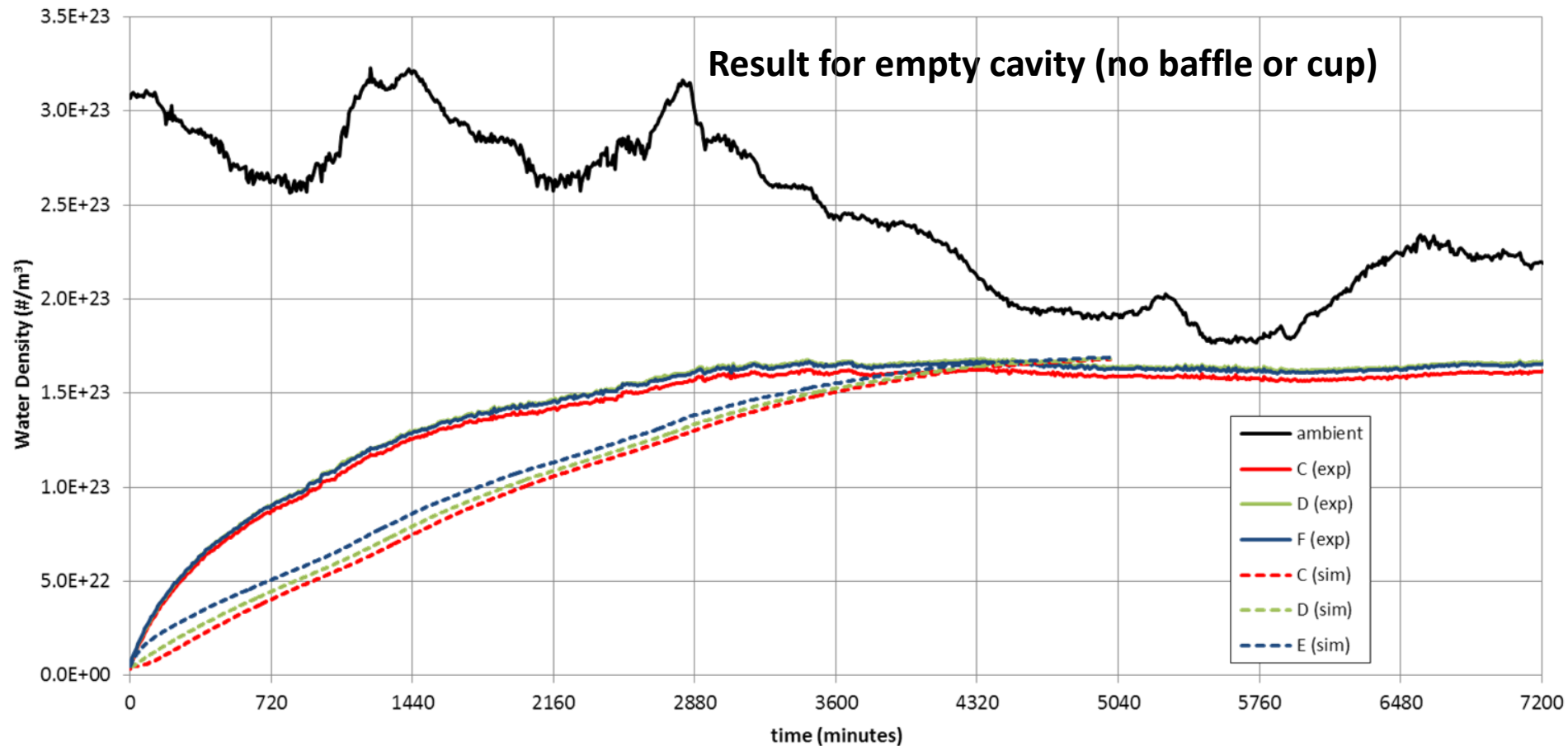
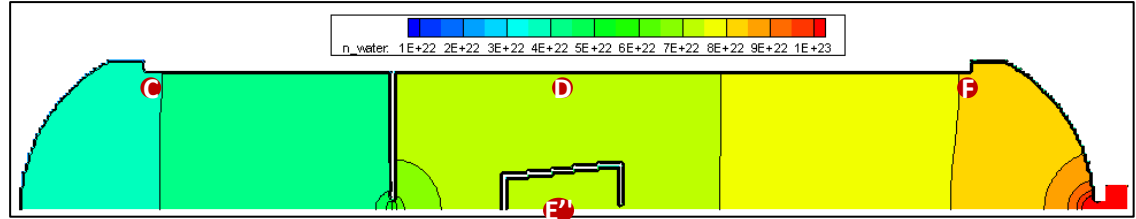

Preliminary AD+NS Results

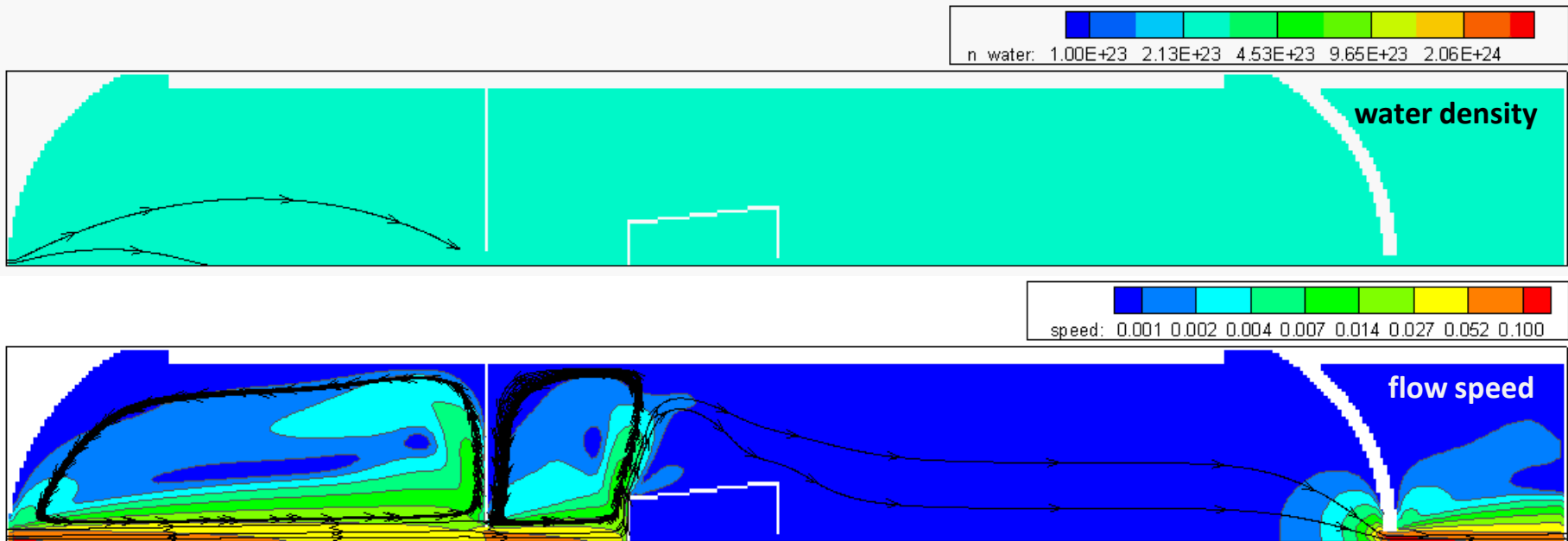

- Advection solver needed a flux limiter: numerical error or Δt too large?
- Velocity streamlines show complex internal flow profile
 - As predicted by Reynolds number, turbulent in the tube and laminar through aperture
 - Areas inside a vortex have a higher water concentration
 - Water from internal volume primarily removed by diffusion due to a concentration gradient

Numerical density limiter results in non-physical mass increase: to be fixed in future work. Also, need turbulent model.

PART III. IMPACT ON PARTICULATES

Numerical Model

- **What is the effect of purge on particulate contamination?**
 - Can use particle tracing code to investigate in details
- Simulation particles traced according to $x^{k+1} = x^k + v^{k+0.5} \Delta t$
 - Particle aspect ratio and area varies randomly
- Particles injected with small random velocity
- Drag Force: $F_d = \frac{1}{2} \rho v^2 C_d A$
 - Drag coefficient $C_d = \frac{24.0}{Re} + \frac{6.0}{1+\sqrt{Re}} + 0.4$
 - Assumed ellipsoidal particles, $A = \pi ab$
- Also gravity: $F_g = mg$, acting in $-z$ direction

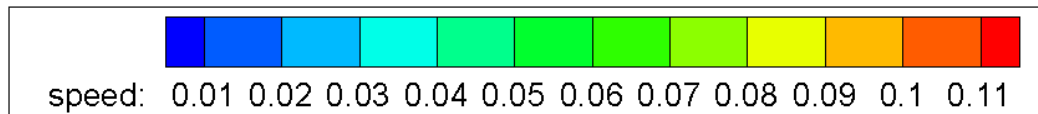

Particle initial position
and **view on next page**



Results

No flow

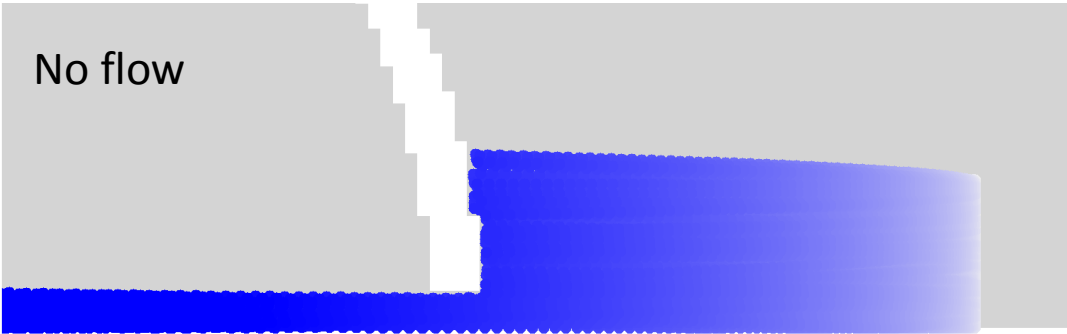

10Å

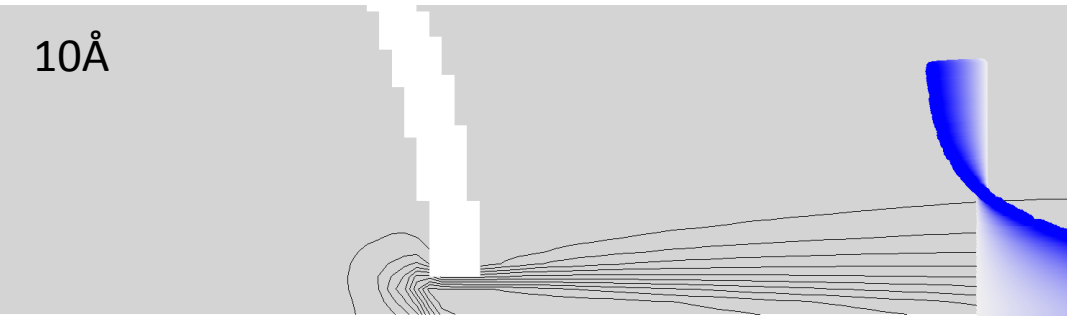

250Å

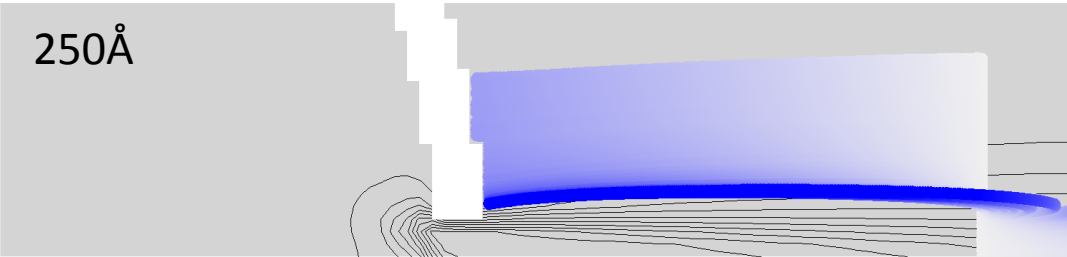

2000Å



- As can be verified by analysis, purge is effective in preventing infiltration of light particulates
- This particular purge not effective for heavy particulates (>2000Å)

Conclusion

- **Performed a dual experimental and numerical effort to study purge and water infiltration**
- Experimental Effort:
 - The variation in internal sensors was less significant than anticipated
 - Adds credence to the simple 0D model if no internal geometry
 - Water density followed exponential decays (as predicted by the simple model), however, a double exponential resulted in a better fit
 - However, the fit parameters differed from analytical values
- Numerical Study:
 - The combined Advection/Diffusion and incompressible NS approach seems as a viable way to study purge and water infiltration in more detail
 - Results show generally good agreement with experiment but additional work is needed:
 - Density limiter was needed with advection term, resulted in mass increase
 - Performed particle tracing study
- Future work: **(1)** turbulent model, **(2)** incorporate detailed surface adsorption/desorption model, **(3)** perform detailed study using parallel resources

Acknowledgements

- The authors would like to acknowledge the following individuals:
 - John Newcome (GOES-R engineering co-op) for building sensors and the experimental setup, and for assisting with data collection and reduction
 - Therese Errigo (MMS project) for providing funding for the initial experimental effort
 - Gregory Bennett (GOES-R engineering co-op) for performing initial research on pressure and humidity sensors and John Fiorello and Zoe Dormuth (GOES-R engineering interns) for supporting data collection activities
 - Steve McKim, Hal Baesh, and the rest of GSFC propulsion lab for making the testing possible
 - Rob Studer at GOES-R, and Mark Secunda, David Hughes, Mike Woronowicz and Evelyn Lambert at GSFC contamination branch for fruitful discussions on purge testing and analysis
- This work was supported by GOES-R and MMS projects, under Contract NG07CA21C (MSES IIA)

Questions?