

# Stage-by-Stage and Parallel Flow Path Compressor Modeling for a Variable Cycle Engine

**NASA Advanced Air Vehicles Program – Commercial Supersonic  
Technology Project - AeroServoElasticity**



**George Kopasakis**

NASA Glenn Research Center  
Cleveland Ohio

**Joseph W. Connolly** – NASA Glenn

**Larry Cheng** - University of Washington  
Seattle, Washington

**51<sup>st</sup> AIAA Joint Propulsion Conference  
July 27 – 29, 2015  
Orlando, FL**



# Outline

- **Background**
- **Stage-by-Stage Compressor Model**
- **Parallel Flow Path Model**
- **Results**
- **Conclusions**



# Background - AeroPropulsoServoElasticity (APSE) Goals

- Develop dynamic propulsion system and aero-servo-elastic/aerodynamic models, and integrate them together with atmospheric turbulence to study the dynamic performance of supersonic vehicles for ride quality, vehicle stability, and aerodynamic efficiency.
- Supersonic vehicles are slender body with more pronounced AeroServoElastic (ASE) modes, which can potentially couple with propulsion system dynamics to present performance challenges.
- Approach for Propulsion System:
  - Develop 1-Dimensional (1D) component models and 2D models where appropriate to be comparable in frequency range to ASE models.
  - Integrate Propulsion with ASE to form a closed-loop dynamic system model to study performance.

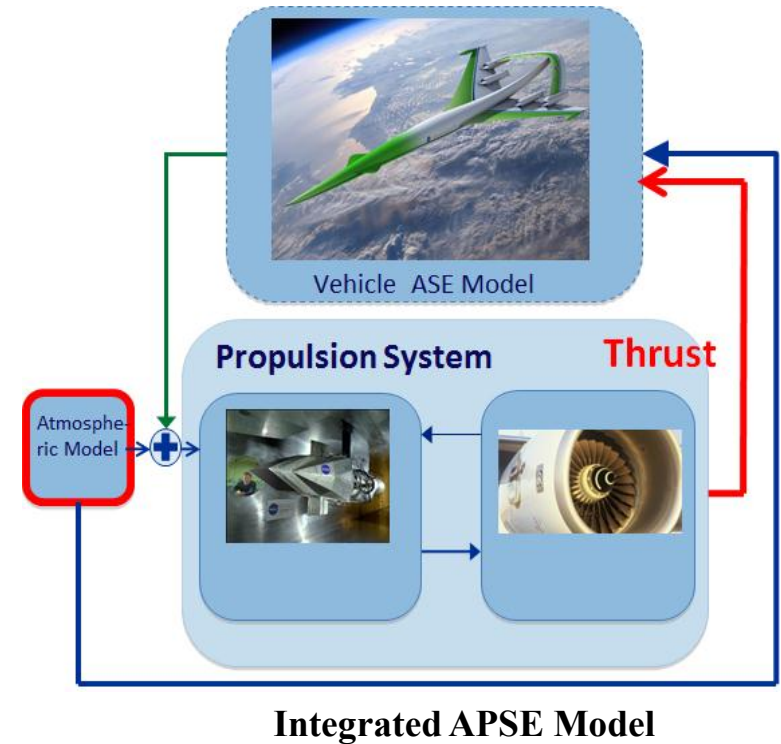

# Background

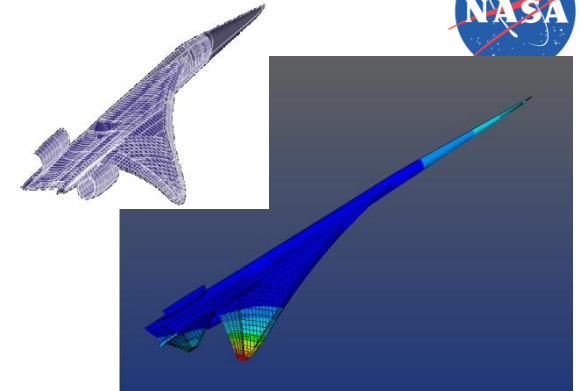

Vehicle Structure – CFL3D/FUN3D & State Space Modeling

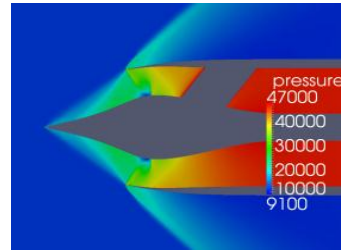

Inlet & Nozzle quasi-1D, 2D/3D Modeling

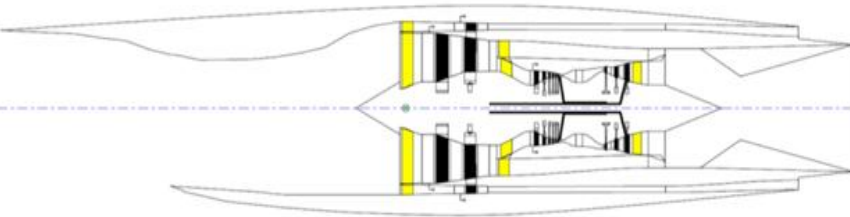

Propulsion System Quasi-1D and lump volume component modeling

## APSE Component Modeling

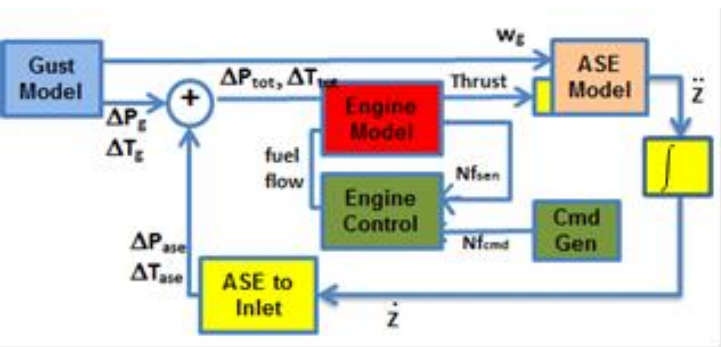

Integrated APSE (propulsion & structure) vehicle modeling in MATLAB/Simulink

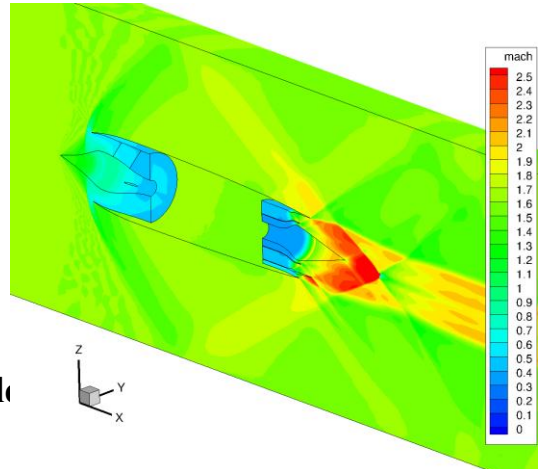

FUN3D Propulsion Model

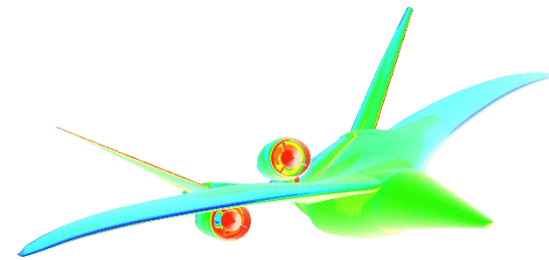

Integrated FUN3D Vehicle Model

## APSE Integrated modeling

Presented here – Extension of engine component modeling to address vehicle response to flow distortion



# Background - Propulsion System Dynamic Modeling

- Modeling all the components with lump volume dynamics and performance characteristics, and adding combustor and shaft dynamics and variable geometry (Inlet Guide Vanes), with lump or quasi-1D inlet and nozzle models
- Higher fidelity models include 2D/3D inlet & nozzles, stage-by-stage for compressors and turbines, and parallel flow path modeling.

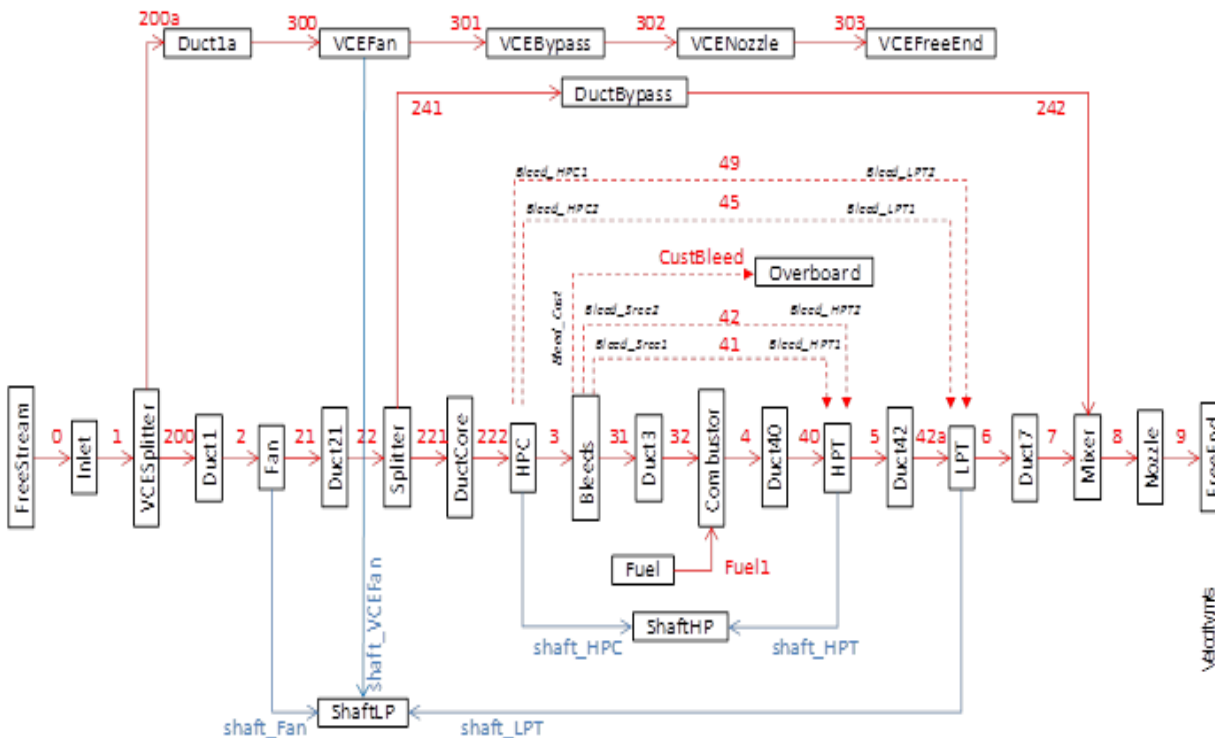

**Variable Cycle Engine (VCE) Model**

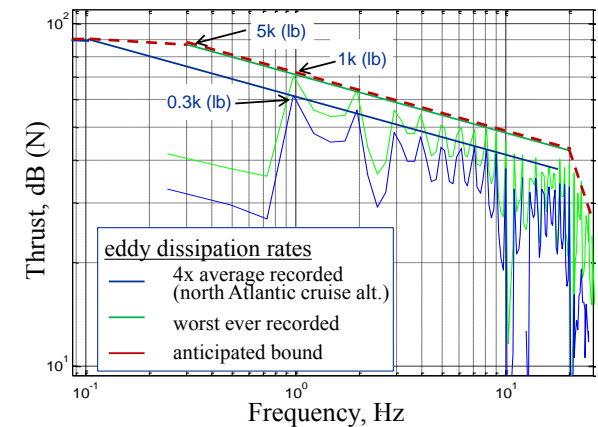

**Open Loop thrust spectral Densities**

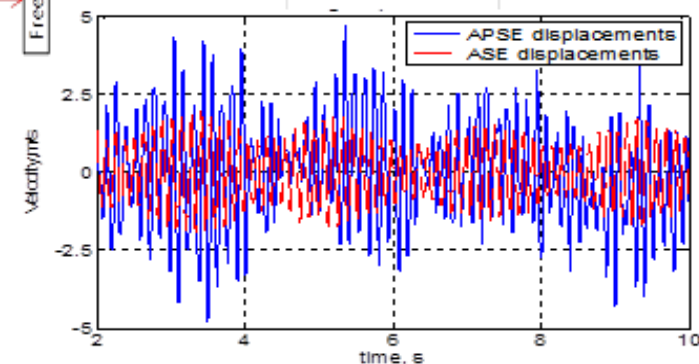

**Closed loop vehicle displacements**

# Stage-by-Stage Compressor Model

**What is it about:** The stage-by-stage model is taking the lump volume compressor model w/ variable geometry and breaking it down into multiple volumes – one for each compressor stage

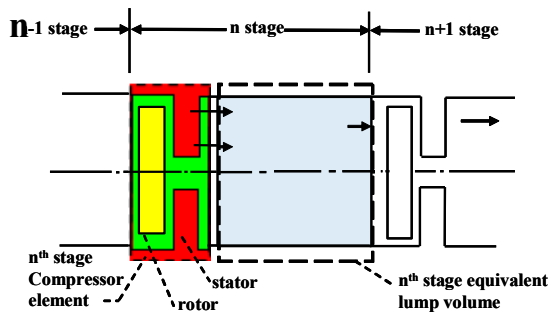

Compressor stage

$$\frac{d}{dt} \rho_{sv,n} = \frac{1}{V_n} (\dot{W}_{c,n} + \dot{W}_{c,n+1} - \dot{W}_{b,n})$$

$$\frac{d}{dt} \dot{W}_{c,n} = \frac{A_n g}{l_n} (P_{tc,n} - P_{tv,n}) \left( 1 + \frac{\gamma_{cp} - 1}{2} M_{mv}^2 \right)^{\frac{-\gamma_{cp}}{\gamma_{cp} - 1}}$$

$$\frac{d}{dt} (\rho_{sv,n} T_{tv,n}) = \frac{\gamma_{cp}}{V_n} (T_{tc,n} \dot{W}_{c,n} - T_{tv,n} \dot{W}_{c,n+1} - T_{tv,n} \dot{W}_{b,n})$$

$$P_{tv,n} = \left( 1 + \frac{\gamma_{cp} - 1}{2} M_n^2 \right)^{\gamma_{cp} - 1} \rho_{sv,n} R T_{tv,n}$$

Stage Volume Dynamics

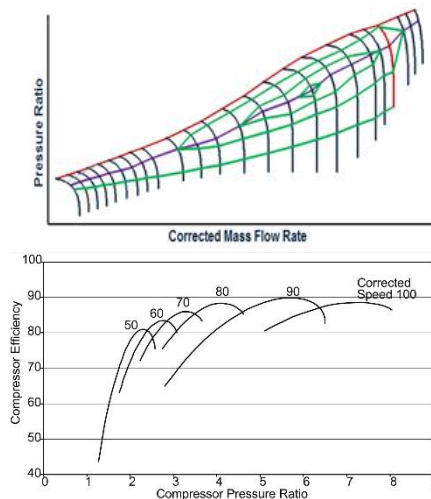

Stage Maps

- Purpose:** (1) Develop higher fidelity compressor model  
 (2) Precursor for developing parallel flow path compressor model

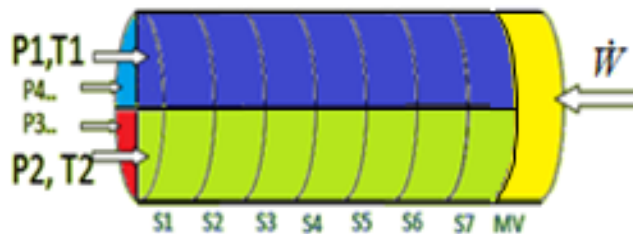

Parallel flow Path compressor model



# Stage-by-Stage Compressor Model Methodology



## Scaling:

- Lump Volume parameters are scaled by the root or the by the reciprocal of the number of stages, ex.  $P_{r,st} = \sqrt[J]{P_{r,imp}}$  for pressure, and  $l_{st} = (1/J) l_{imp}$  for length.
- Scaling is done in successive steps, like  $3/4$ ,  $1/2$ ,  $1/3$  ... in order to develop the final stage size by reiterating and substituting final conditions for initial conditions. Because initial conditions are too far off to converge in a single step.

## Stacking Compressor Stages:

- **Problem:** Stacking stages in one step causes unmatched conditions for stage Mach no's, cross section areas, and flow conditions – unstable response.

- **Solution:** Disconnect Mach no. estimator and stack one stage at a time – calculate stage Mach no. and each successive stage cross section area by,  $M_n = M_{in} - \frac{n}{J} (M_{in} - M_{out})$ ,

and  $A_n = \frac{\dot{W}_{c,n}}{\rho_{sv,n} M_n \sqrt{\gamma R T_{s,n}}}$  and reiterate by substituting final flow conditions for initial conditions and refine area calculations.

- Reconnect Mach no. estimator, fine tune stage operating point, ex.  $N_{c,n} = \frac{N}{N_{d,n}} \sqrt{T_{ref}/T_{tv,n-1}}$ , and stack next downstream stage to repeat process until all stages connected.

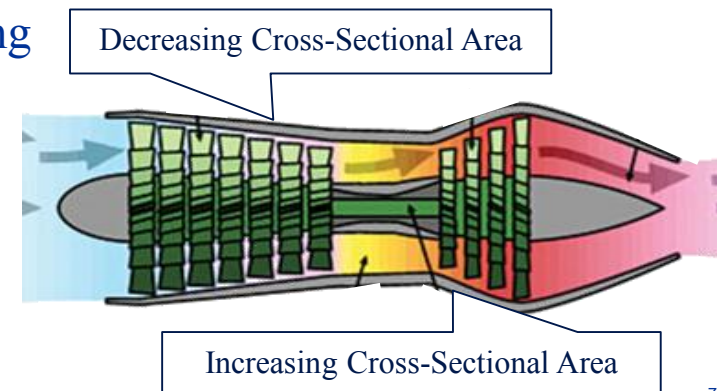

# Parallel Flow path Compressor Model Methodology

**What is it about:** Starting from stage-by-stage model subdivide each stage into multiple sectors of same or different size to allow both axial and rotational flow to address flow distortion on the compressor stall dynamics and propulsion/APSE dynamics.

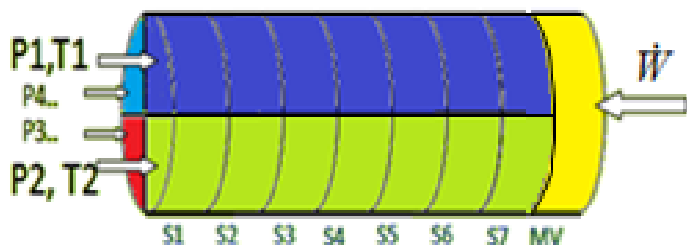

**Parallel flow Path Compressor Model (MV is a mixing volume where flow combines – Variable Guide Vane not shown)**

$$\frac{d}{dt} \rho_{s,mv} = \frac{1}{V_{mv}} (\dot{W}_{mv} - \dot{W}_{cb})$$

$$\frac{d}{dt} \dot{W}_{mv} = \frac{A_{mv} g}{l_{mv}} \left[ \sum_{m=1}^q (\beta_m P_{tm,n=k}) - P_{t,mv} \right] \left( 1 + \frac{\gamma_{cp} - 1}{2} M_{mv}^2 \right)^{\frac{-\gamma_{cp}}{\gamma_{cp} - 1}}$$

$$\frac{d}{dt} (\rho_{s,mv} T_{t,mv}) = \frac{\gamma_{mv}}{V_{mv}} \left[ \dot{W}_{mv} \sum_{m=1}^q (\beta_m^2 T_{tm,n=k}) - \dot{W}_{cb} T_{t,mv} \right]$$

## Mixing Volume Dynamics

-- Nozzle Plug Model also developed to calculate mass flowrate at the exit boundary and run compressor as a test rig in simulation

$$\frac{\partial \rho_s}{\partial t} = -\frac{\partial(\rho_s u)}{\partial x} - \frac{1}{r} \frac{\partial(\rho_s w)}{\partial \varphi}$$

$$\frac{\partial(\rho_s u)}{\partial t} = -u \frac{\partial(\rho_s u)}{\partial x} - \frac{w}{r} \frac{\partial(\rho_s u)}{\partial \varphi} - \frac{\partial P_s}{\partial x}$$

$$\frac{\partial(\rho_s w)}{\partial t} = -u \frac{\partial(\rho_s w)}{\partial x} - \frac{w}{r} \frac{\partial(\rho_s w)}{\partial \varphi} - \frac{1}{r} \frac{\partial P_s}{\partial \varphi}$$

$$\frac{\partial}{\partial t} \left( \frac{P_s}{\gamma - 1} + \frac{\rho V^2}{2} \right) = -\frac{\partial}{\partial x} \left[ \left( \frac{\gamma P_s u}{\gamma - 1} + \frac{\rho u^3}{2} \right) \right] - \frac{1}{r} \frac{\partial}{\partial \varphi} \left[ \left( \frac{\gamma P_s w}{\gamma - 1} + \frac{\rho w^3}{2} \right) \right]$$

## Volume Dynamics of Stage Sector

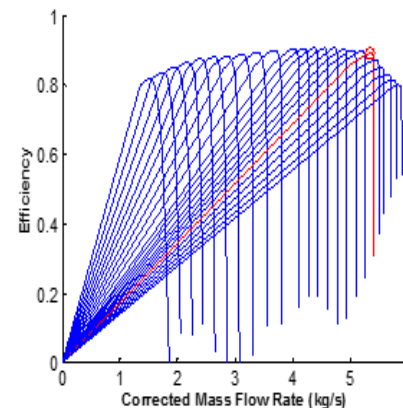
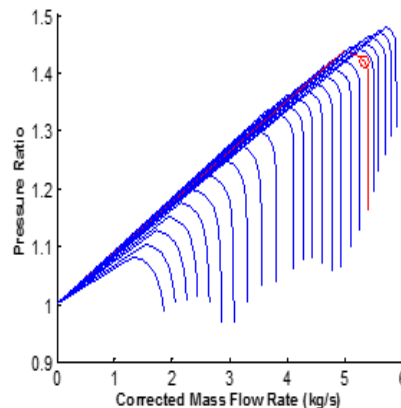

## Maps of Stage Sector Extended to Stall Region



# Results



- Previously lump volume dynamic modeling of engine components, including compressor, were verified against experimental results.
- The stage-by-stage model is an extension of the lump volume with respective stage volume dynamics and matches steady state performance

- This model qualitative compared to a stage-by stage compressor model found in literature (different no. of stages and potentially diff. geometry)

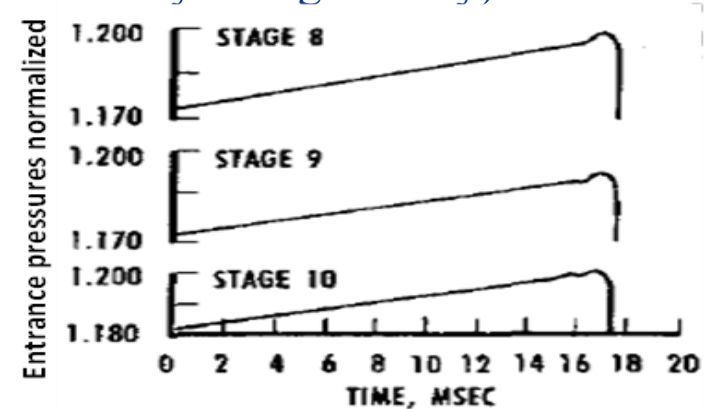

**Table 1. Stage-by-stage and lumped volume compressor model steady state comparison**

Compressor	Stage-by-Stage	Lump Volume	Percent Error
Pres. Out (Pa)	1,219,493	1,219,867	0.031%
Temp. Out (K)	855.19	856.59	0.163%
Massrate In (kg/s)	18.43	18.43	0%

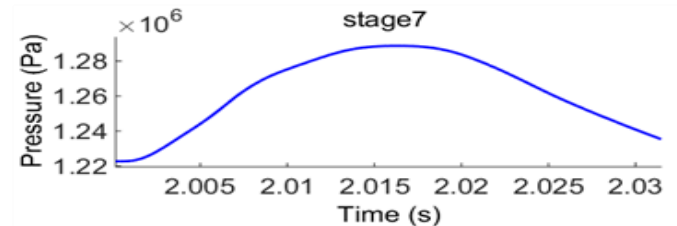
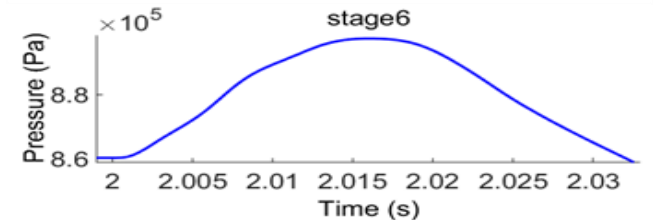

Qualitative comparisons (top DYNTECC, bottom This model. Onset of stall ~ the same, stall behavior slower – choice of time constant

# Results – Response to Flow Distortion Pulse

-- Pressure distortion pulse applied to path 1, which primarily effects path 1 & 3.

-- Flow uniformity is not achieved by the time flow reaches compressor exit as originally assumed.

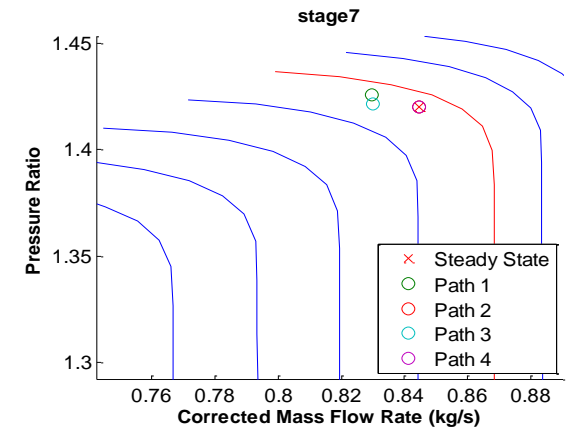
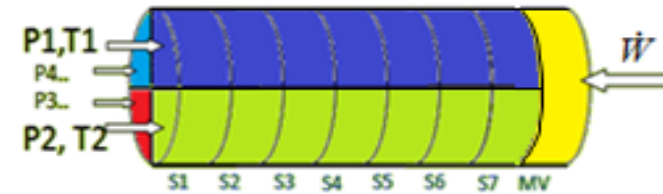
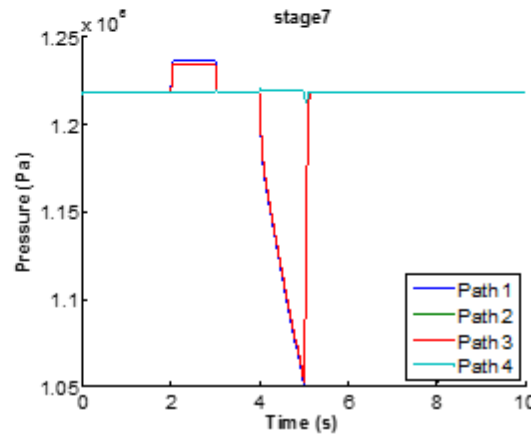
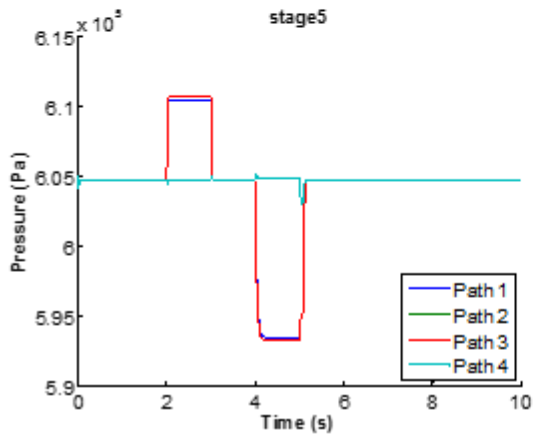
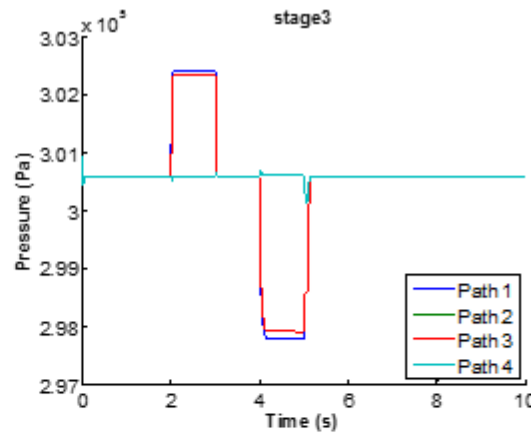
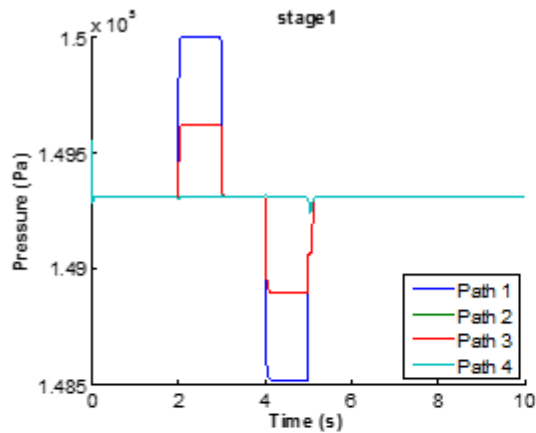

**Stage 7 shift in its operating conditions due to relative light distortion applied to path 1**



-- Pressure distortion pulse applied to path 1, sufficiently large to cause stall

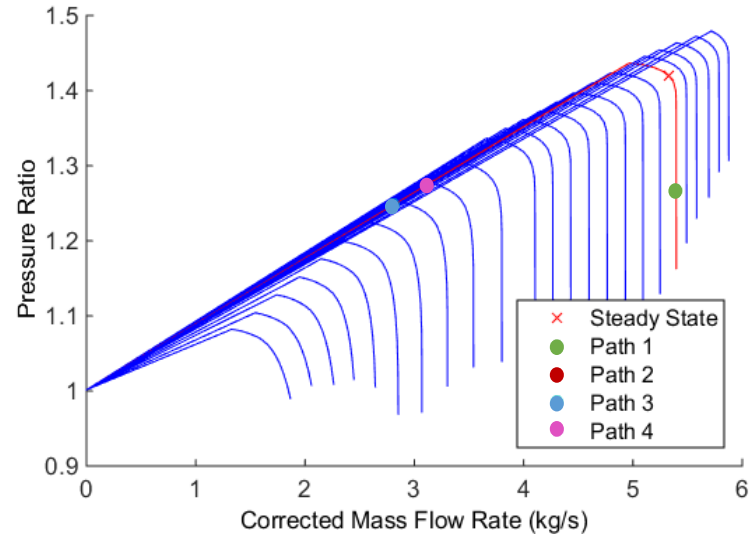
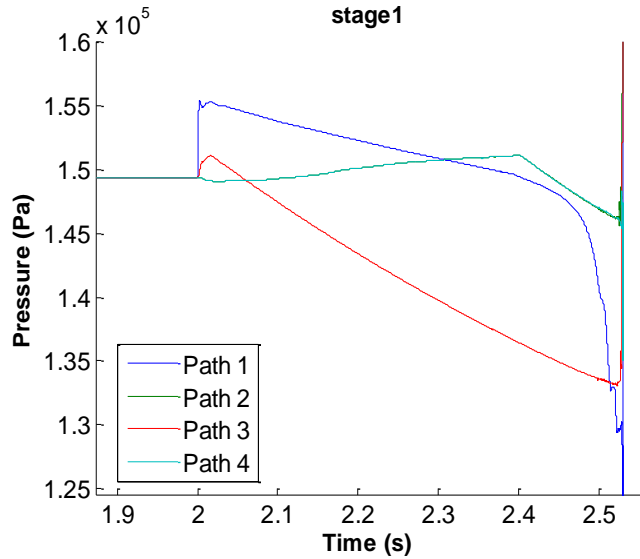

**Snap shot of stage 7 as its sectors transition into stall conditions**

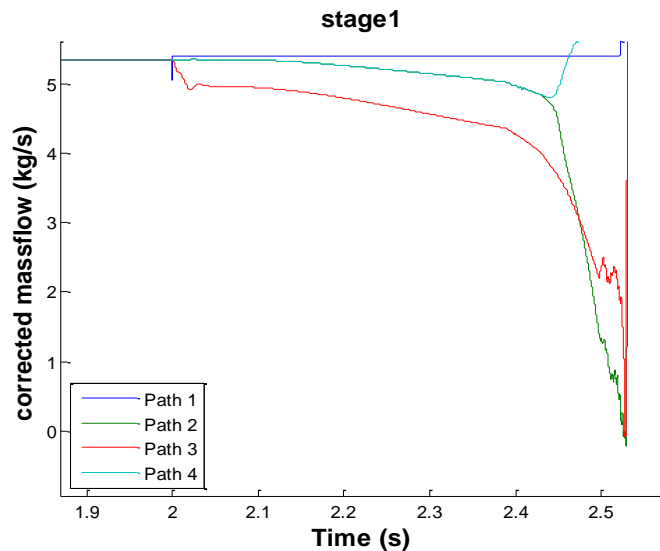



# Results – Rotational Velocity & Frequency Response Comparisons

-- While distortion on path 1 primarily effects axial flow of path 1 & 3, it effects rotational flow of path 2 & 4.

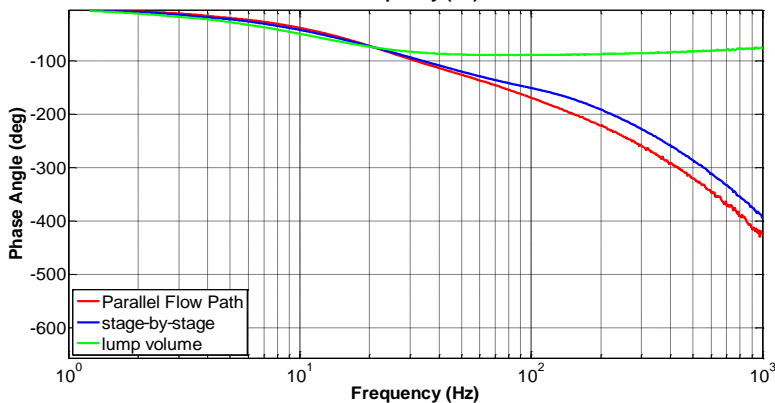
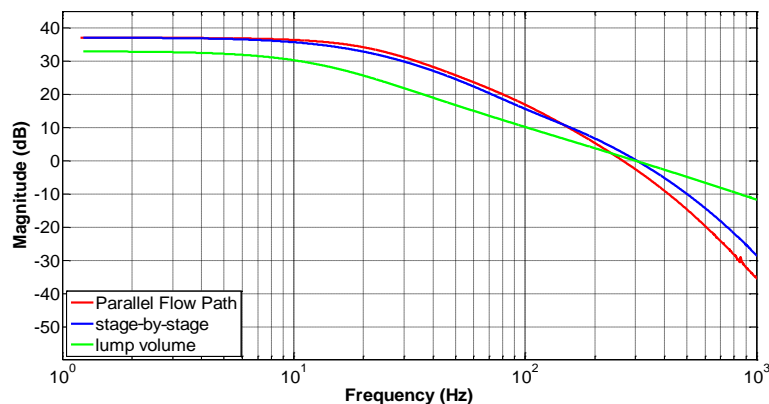

**Pressure frequency response comparisons for the three Compressor Models**

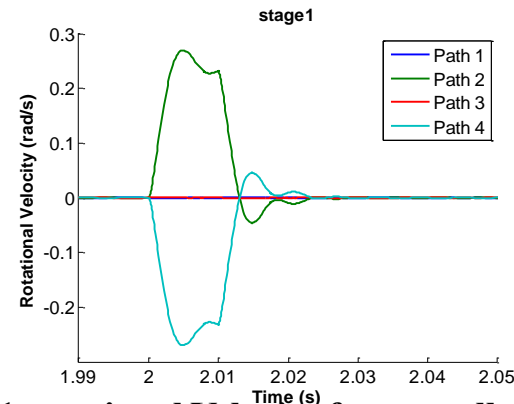

**Stage 1 rotational Velocity for a small non-stalling pressure pulse applied to path 1**

- The frequency response of the stage-by-stage and parallel flow path compressor models deviate significantly from that of the lump volume model
- This difference would be significant for propulsion and APSE dynamics
- The difference between stage-by-stage and parallel flow path models is less significant, but could be important for phase ( $\sim 10^0$  difference at 60 Hz) could be significant.
- This comparison is for non-stall, but the stall dynamics would be expected to be significant



# Why Propulsion Dynamics are important- Frequency Range

- ASE modes extend to about 60 HZ when about half the modes are included in the model.
- For that reason propulsion system dynamics need to extend up to approximately 600 Hz in order to also take into account the phase contribution of the propulsion dynamics for the closed loop system.

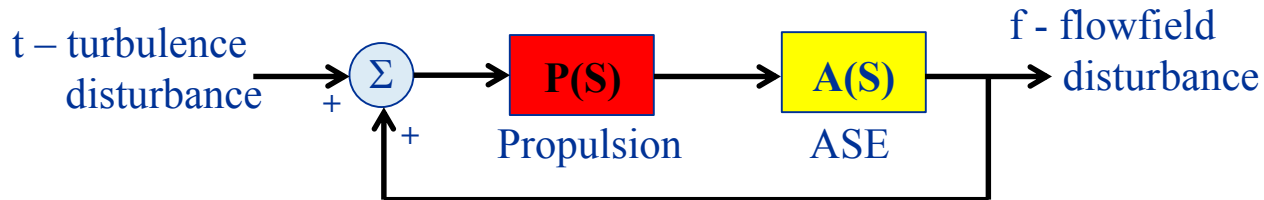

$$\frac{F(s)}{T(s)} = \frac{P(s)A(s)}{1 - P(s)A(s)}$$

Simplified Closed-loop representation of APSE dynamic coupling

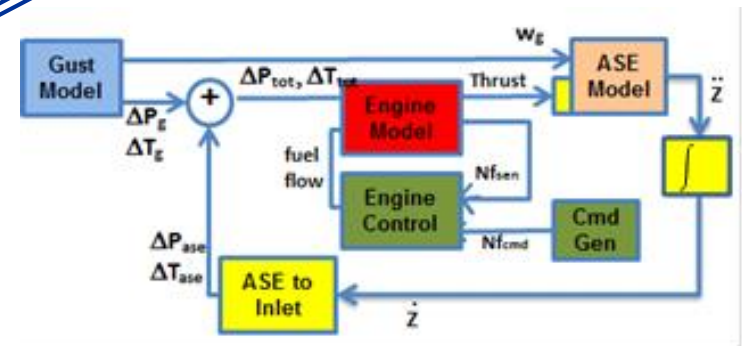

Closed-loop diagram of APSE simulation



# Conclusions

- **Methodologies developed for stage-by-stage and parallel flow path dynamic modeling for Variable Cycle Engine compressor – methodologies generally Applicable for compressor modeling and other engine components.**
- **Established framework for propulsion component modeling to address flow distortion due to vehicle maneuvers.**
- **Stall dynamics are incorporated in this compressor model**
- **Steady state performance verified - modeling dynamics verified to some degree – more work may be needed.**
- **Results show that dynamics of stage-by-stage and parallel flow path models differ significantly from that of the lump volume dynamics, which justifies higher fidelity modeling for propulsion and APSE**
- **Assumption that flow becomes more uniform as it propagates down the compressor stages may need to be relaxed – influences boundary conditions and may influence some results**