



# NASA Fuel Tank Wireless Power and Signal Study

Garrick Merrill

Electronics Design Branch/Space Systems Department

Marshall Space Flight Center

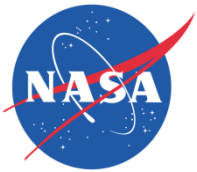

# Overview

Hydro Technologies has developed a custom electronics and mechanical framework for interfacing with off-the-shelf sensors to achieve through barrier sensing solutions. The core project technology relies on Hydro Technologies Wireless Power and Signal Interface (Wi $\psi$ ) System for transmitting data and power wirelessly using magnetic fields. To accomplish this, Wi $\psi$  uses a multi-frequency local magnetic field to produce magnetic fields capable of carrying data and power through almost any material such as metals, seawater, concrete, and air. It will also work through layers of multiple materials.



# Terrestrial Applications

- Initial uses of the Wi $\psi$  system:
  - Oil and gas industry for pipelines
  - US Navy for through hull applications





# Space Applications

- Eliminate protrusions into fuel/oxidizer tanks for sensor wiring helps simplify tank design, reduces leakage, and increases safety.
- Avoiding the use of batteries by powering the sensor externally increases the shelf life and reliability of wireless sensors
- Any vehicle stage or on-orbit fuel depot could greatly benefit from this technology





# Marshall Study

In 2014 we received funding to adapt the Wi $\psi$  system for use with fuel/oxidizer tanks. We worked with Hydro Technologies to determine modifications needed for cryogenic applications. In early 2015 Hydro Technologies delivered the prototype system.

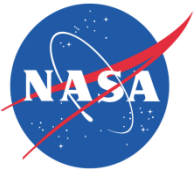

# Marshall Prototype

- Active digital system with two custom-made magnetic core sets, one for power and one for data. Basic temperature sensors were used.
- Passive analog system that eliminates active electronic components inside the tank. Basic temperature sensors were used.
- Sealed aluminum container made with same aluminum alloy and thickness as SLS core stage oxidizer tank.
- Initial functional testing at Hydro Technologies, followed by duplicate testing at MSFC.
- Cryogenic temperature testing using Liquid Nitrogen in Test Area at Marshall Space Flight Center.

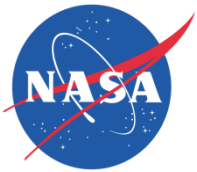

# Active System

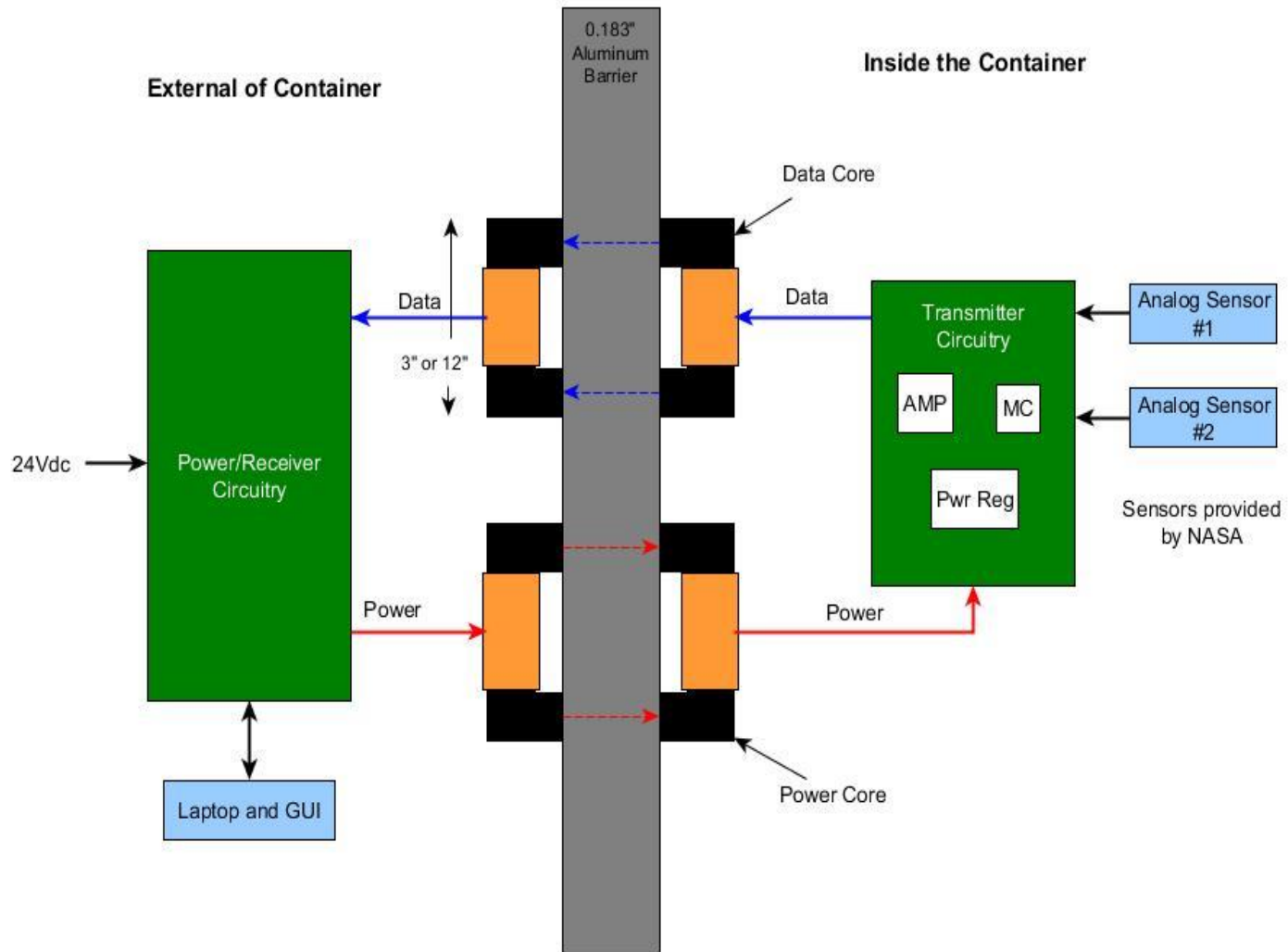

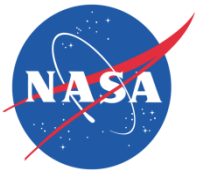

# Active System

Exterior Electronics

Exterior Power and Data Coils

Interior Power and Data Coils

Interior Electronics in Thermos

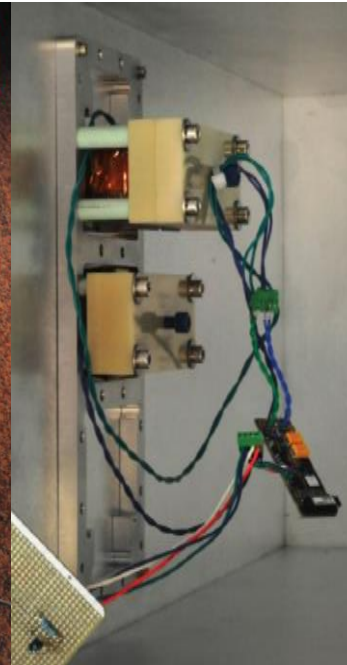
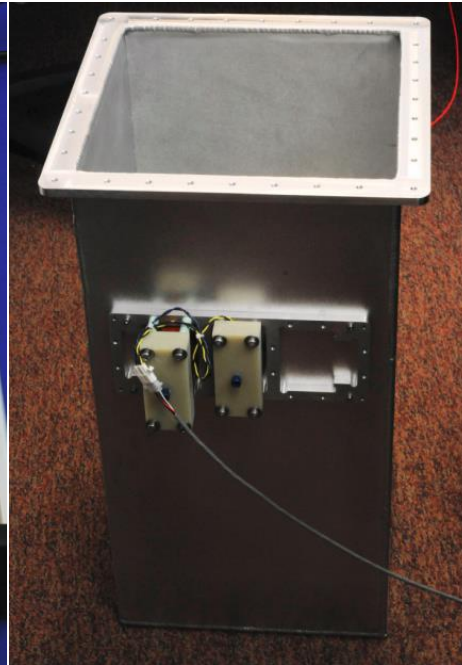
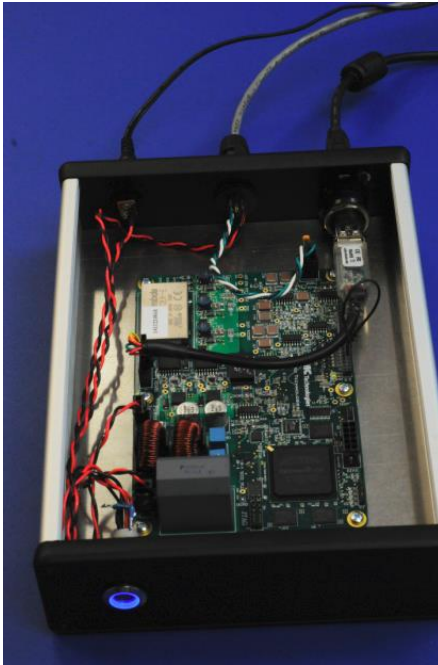



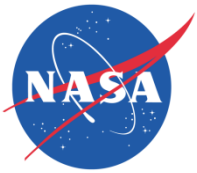

# Passive System

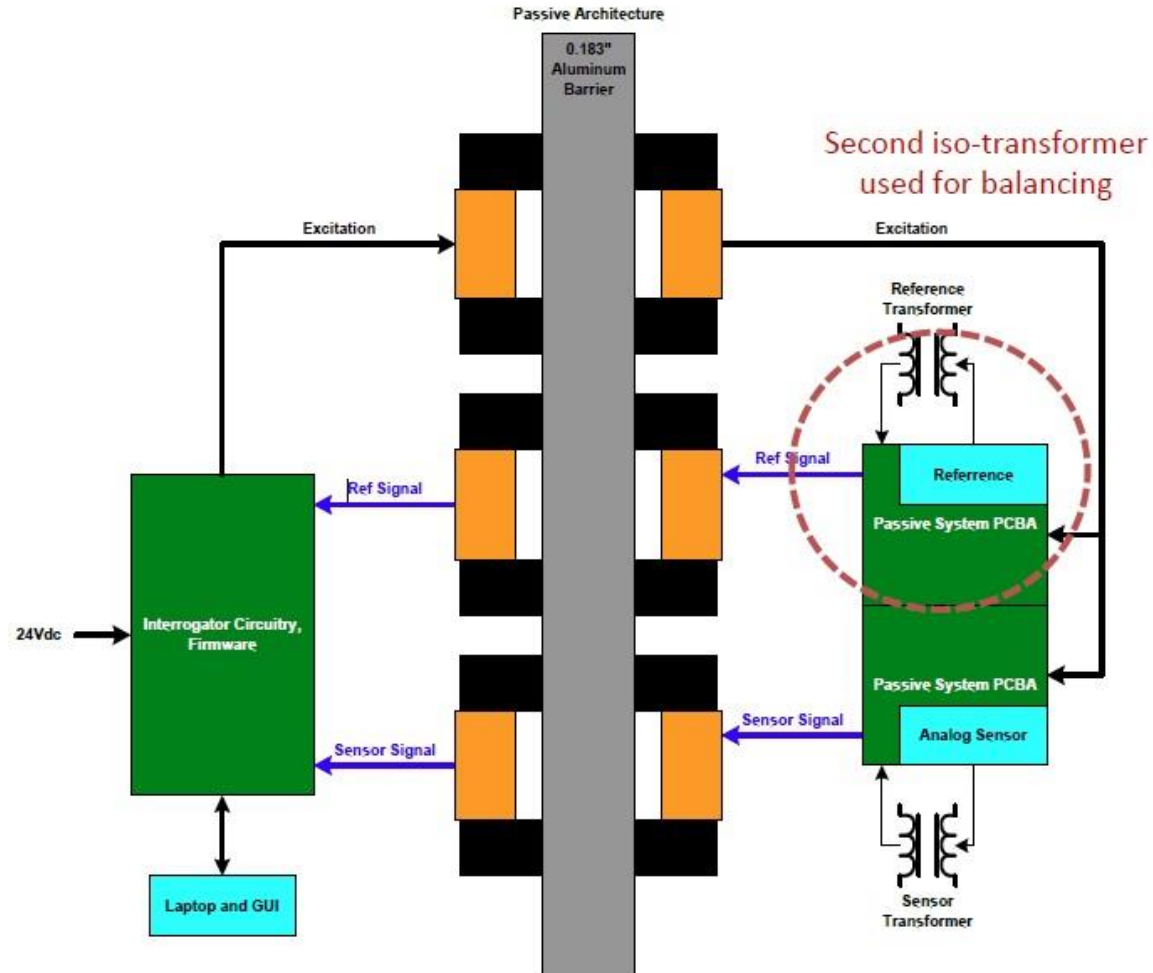

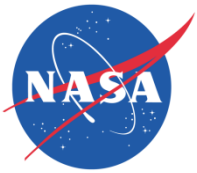

# Passive System

Exterior Electronics



Interior Electronics

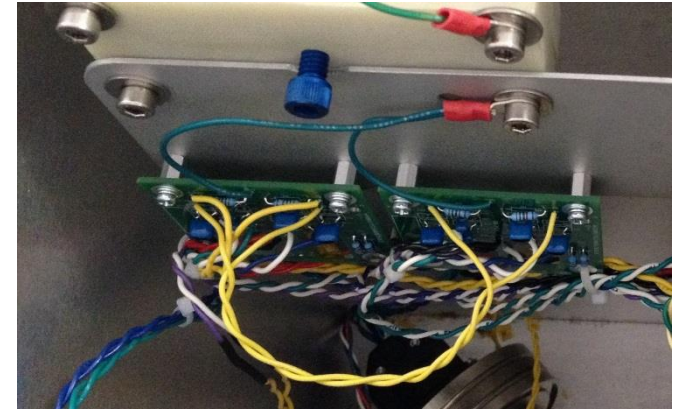

Exterior Coils



Interior Coils



# Simulated Geometry

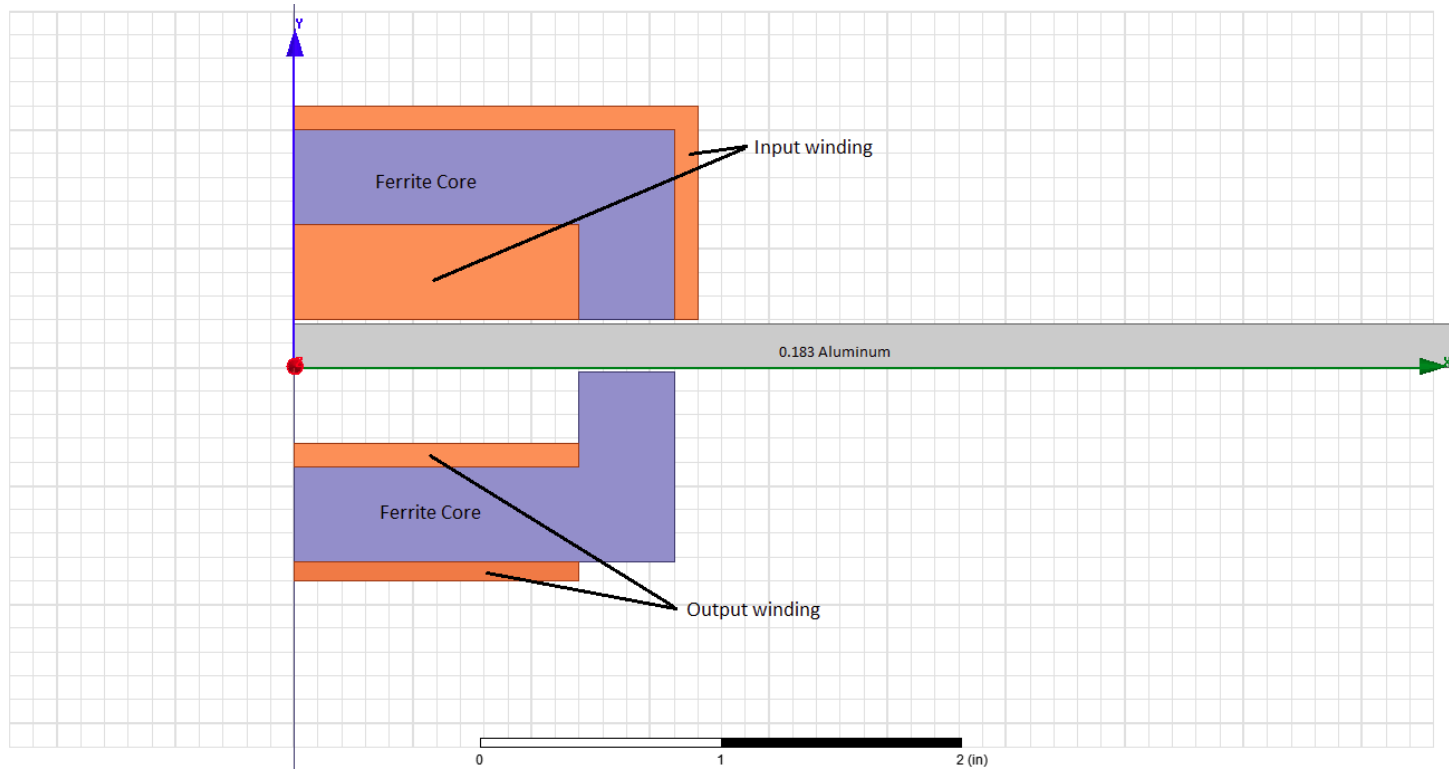

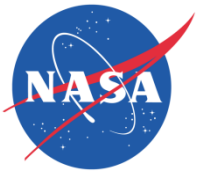

# Magnetic Fields

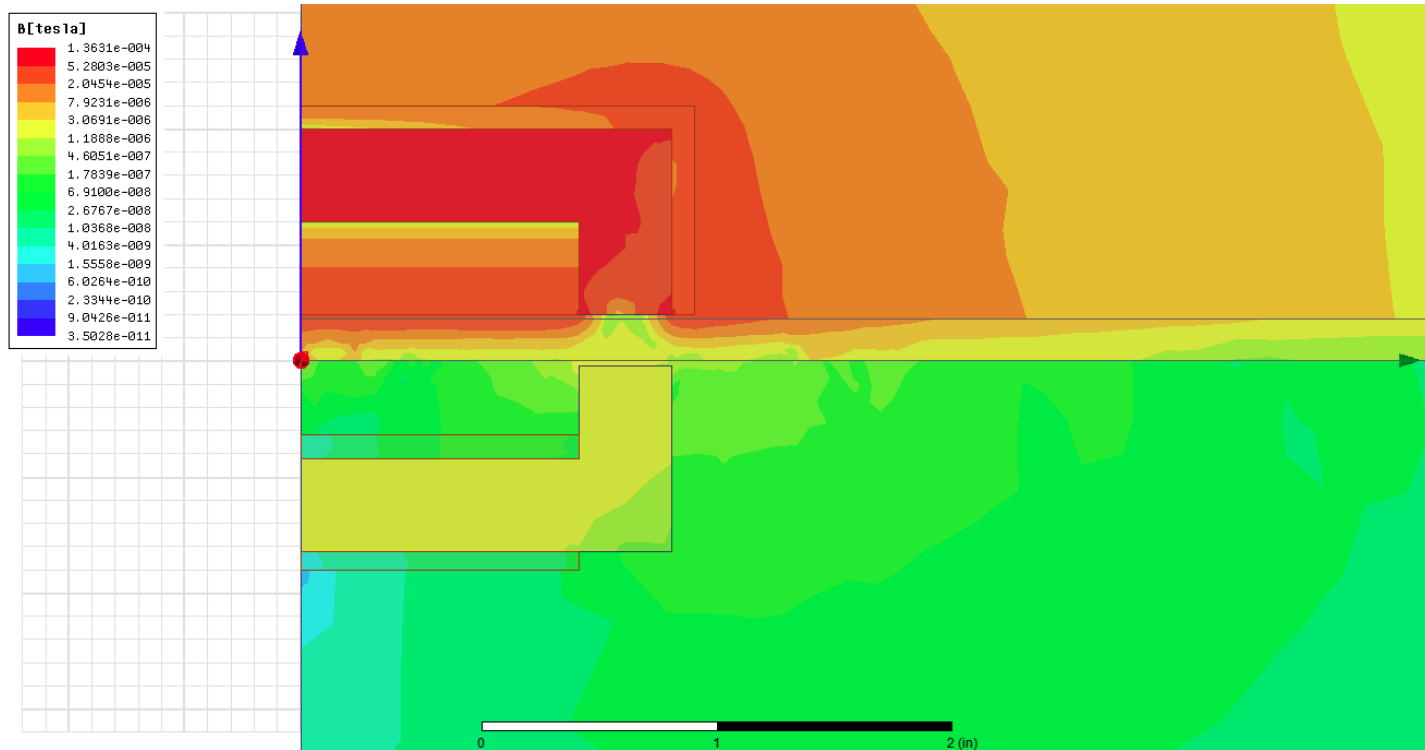

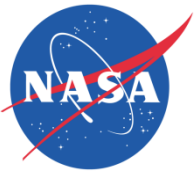

# Sealed Testing

- Solid lid was bolted on and testing verified that 2.4GHz RF signals could not penetrate the tank.
- Both systems performed as expected and transmitted power and data for several hours.





# Sealed Testing

## Passive System

## Active System

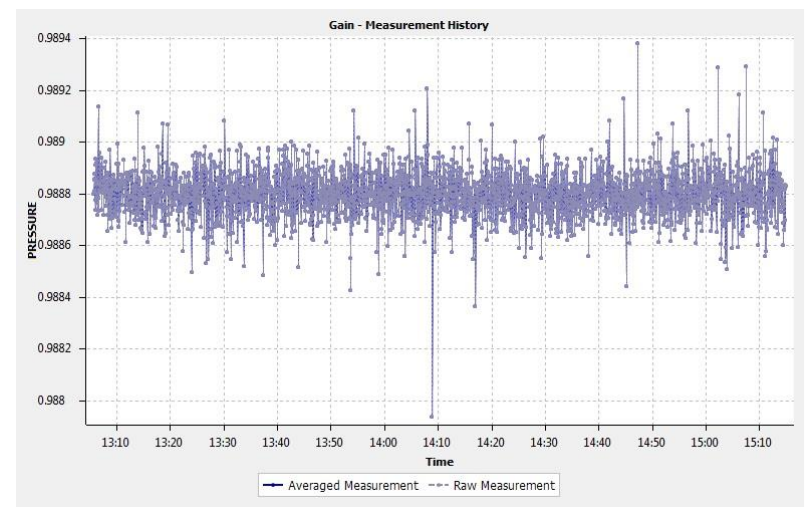
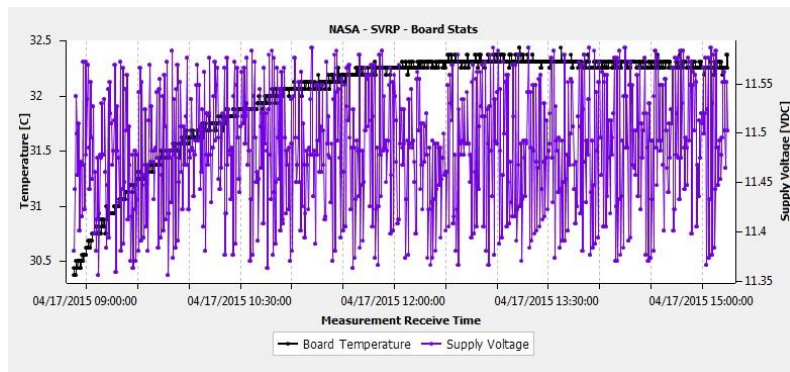
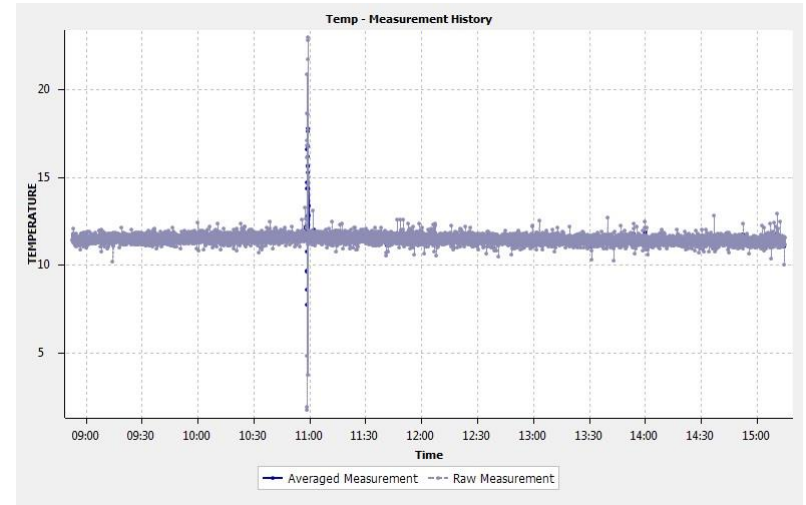
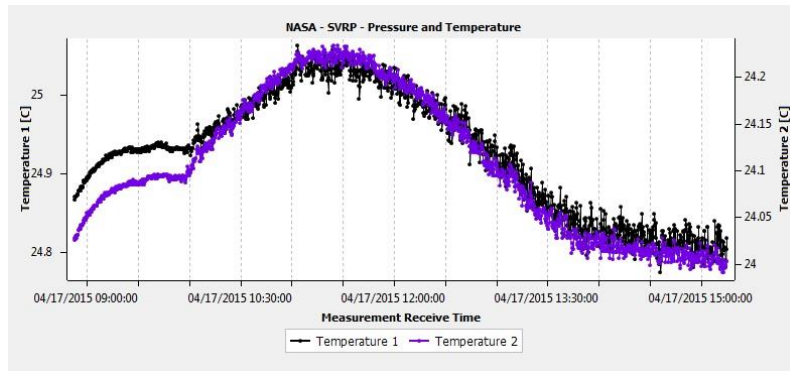





# 1<sup>st</sup> LN Test

- Tank was wrapped and sealed in R6 foil insulation as well as R30 fiberglass insulation to simulate spray foam insulation
- Active system internal electronics were kept out of the tank to allow for extended testing of other components
- Test ran until outside electronics got to -150C and reached equilibrium.

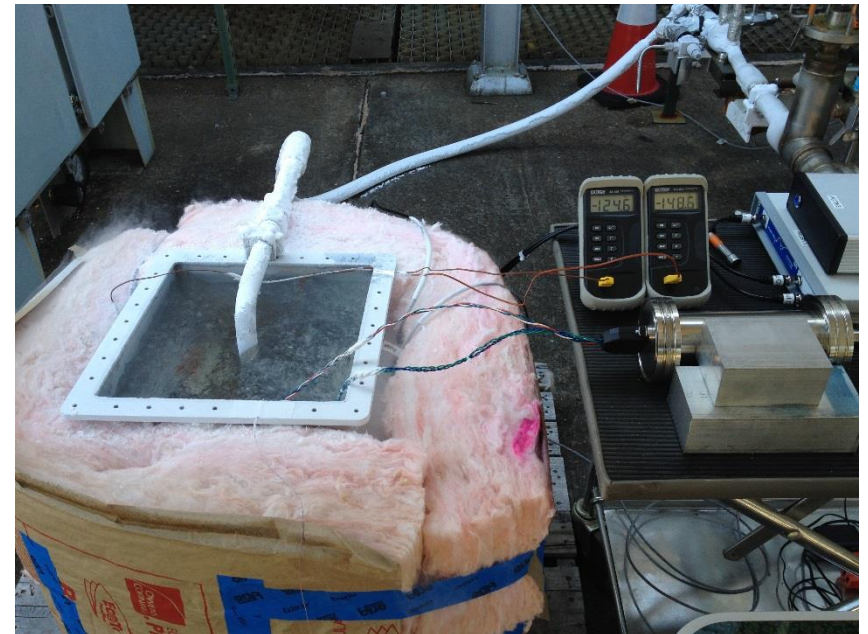

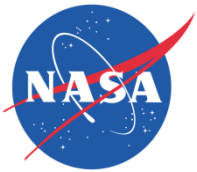

# 1<sup>st</sup> LN Test

## Passive System

## Active System

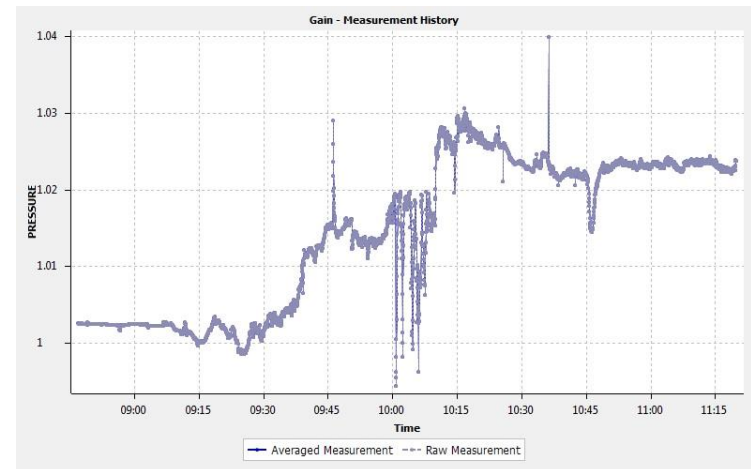
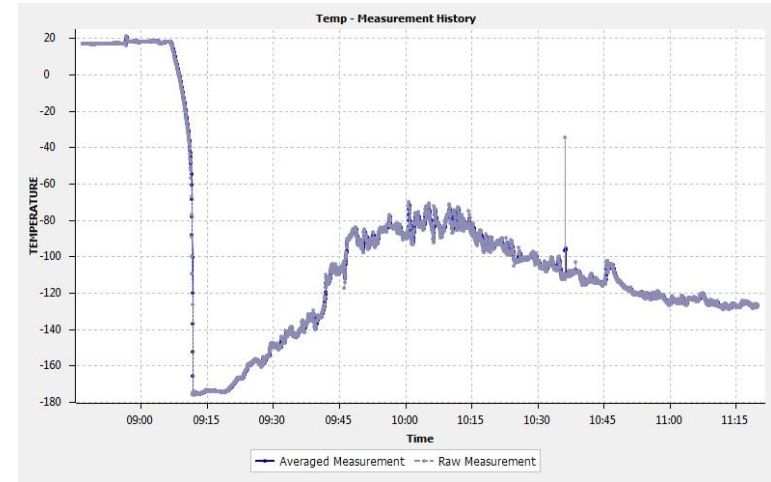
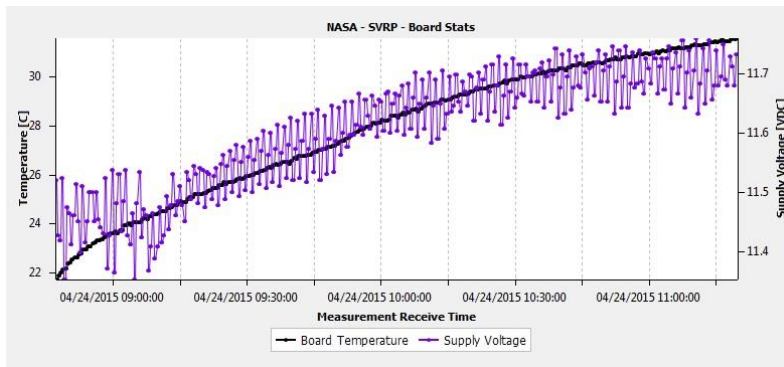
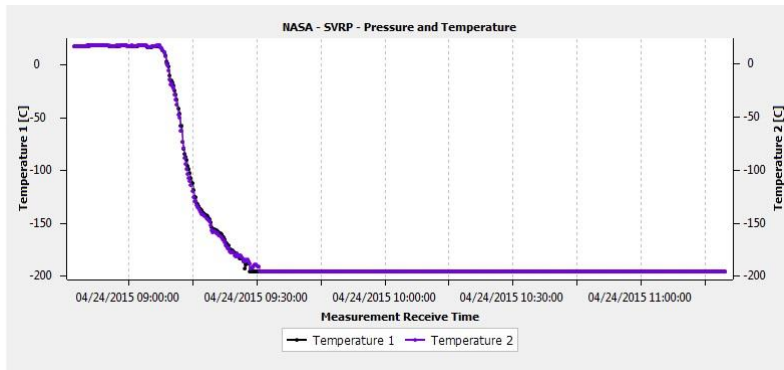



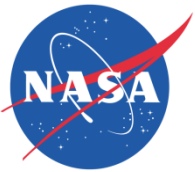

# Post 1<sup>st</sup> LN Test

- Following LN testing inspection revealed cracking and disintegration of coating over coils and corrosion on metal cores
- Passive system had a large offset in temperature readings which may indicate the internal electronics board was affected

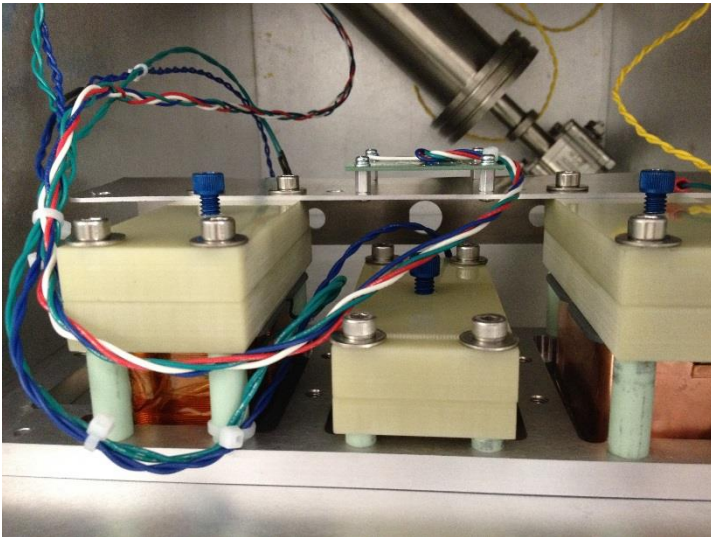

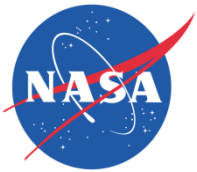

# Post 1<sup>st</sup> LN Test

## Active System

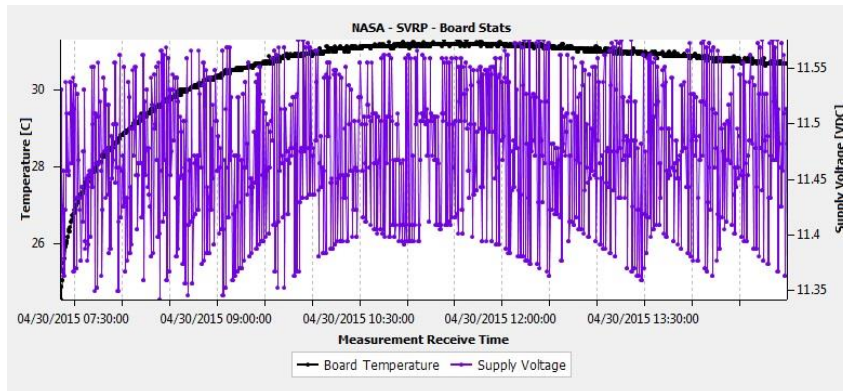
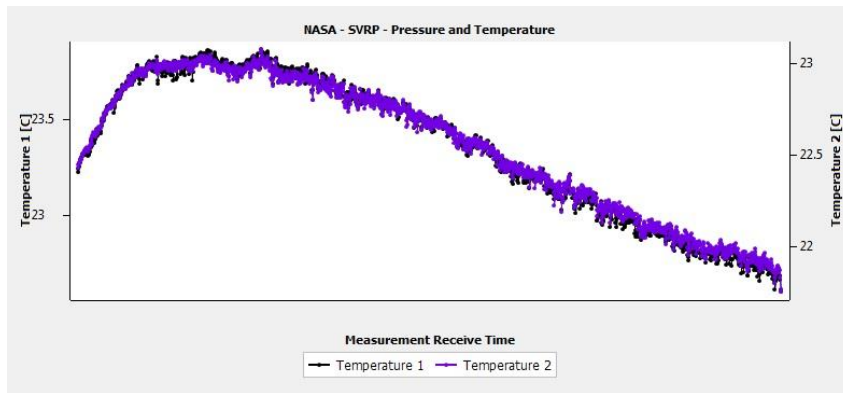

## Passive System

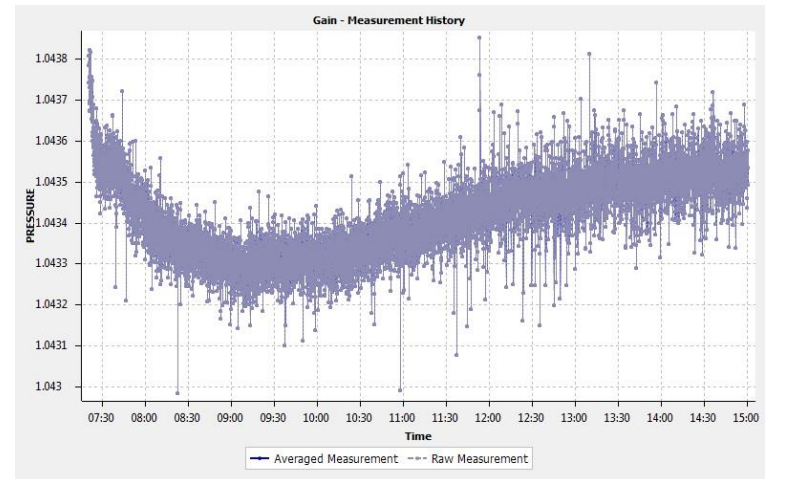
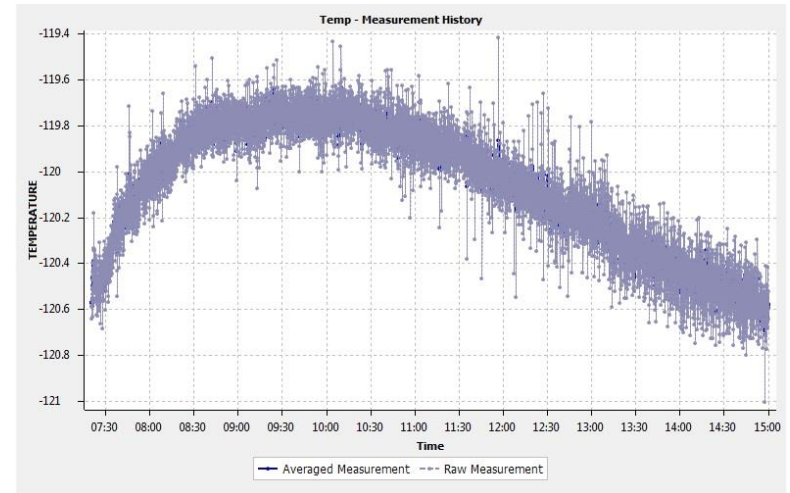



## 2<sup>nd</sup> LN Test

- Tank was wrapped and sealed in R6 foil insulation as well as R30 fiberglass insulation to simulate spray foam insulation
- Active system internal electronics were placed in the tank without any insulation
- LN was added until internal electronics stopped working (-140C) and then tank allowed to slowly warm

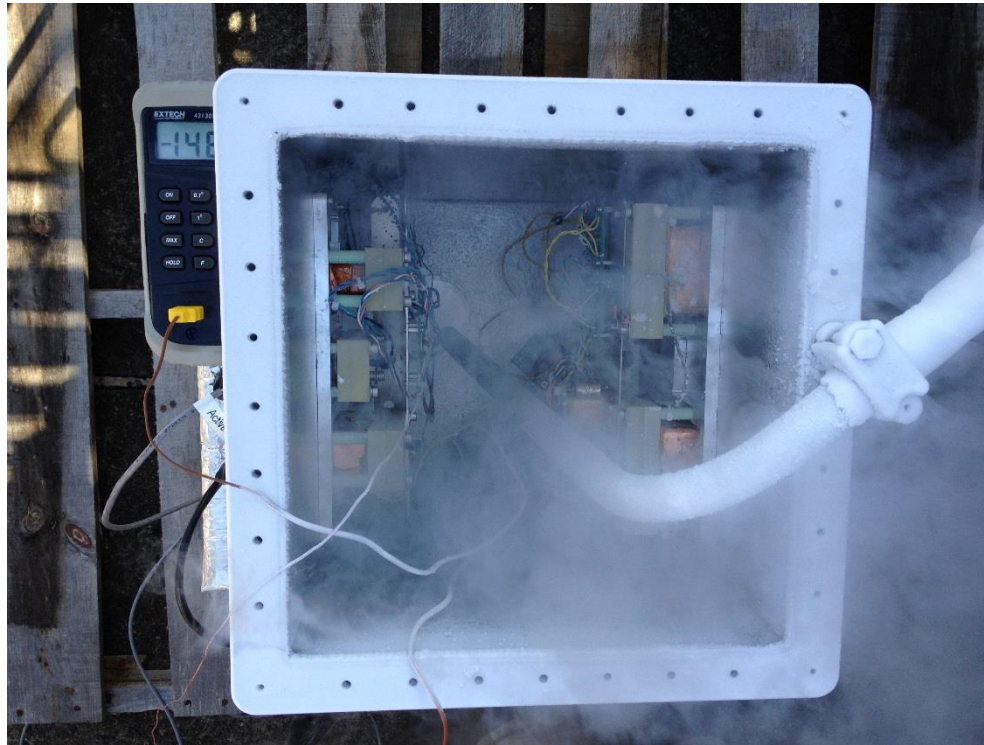



# 2<sup>nd</sup> LN Test

## Active System

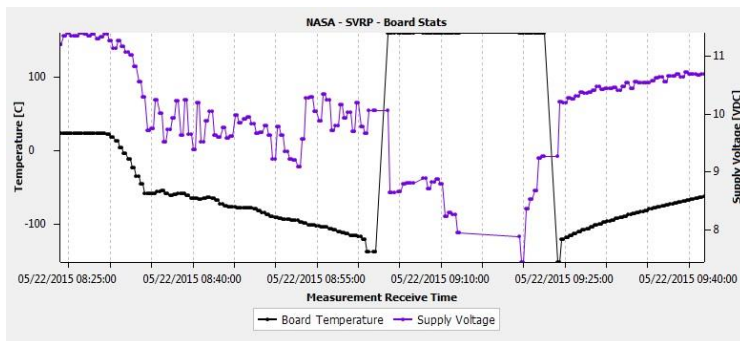
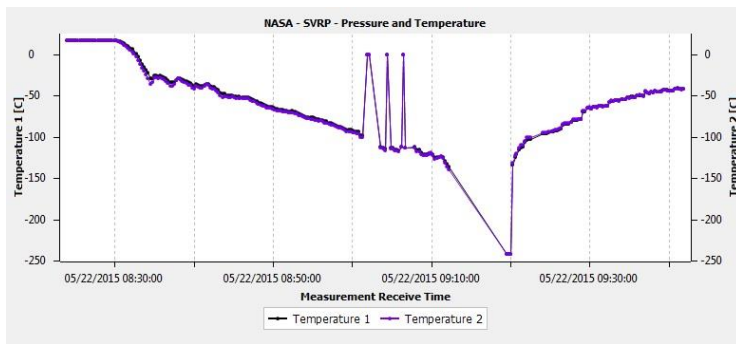

## Passive System

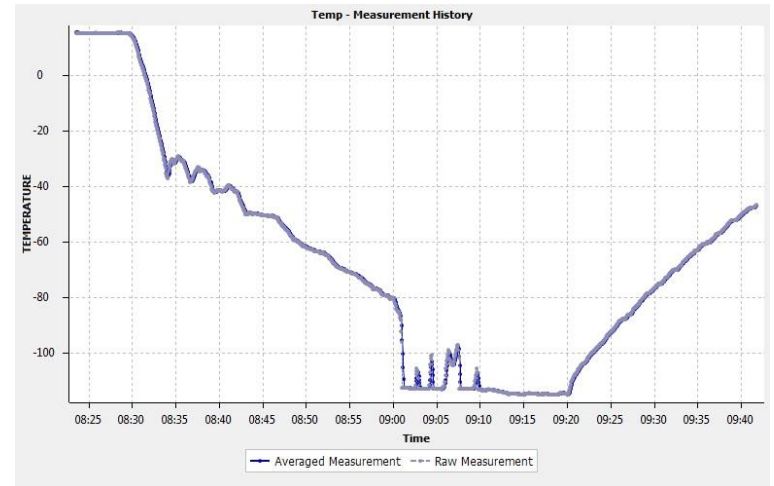





# Post 2<sup>nd</sup> LN Test

- Following LN testing inspection revealed further cracking and disintegration of coating over coils and corrosion on metal cores
- Active system internal electronics seemed unaffected by the test and operated as normal afterwards.

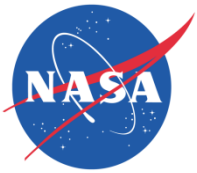

# Post 2<sup>nd</sup> LN Test

## Active System

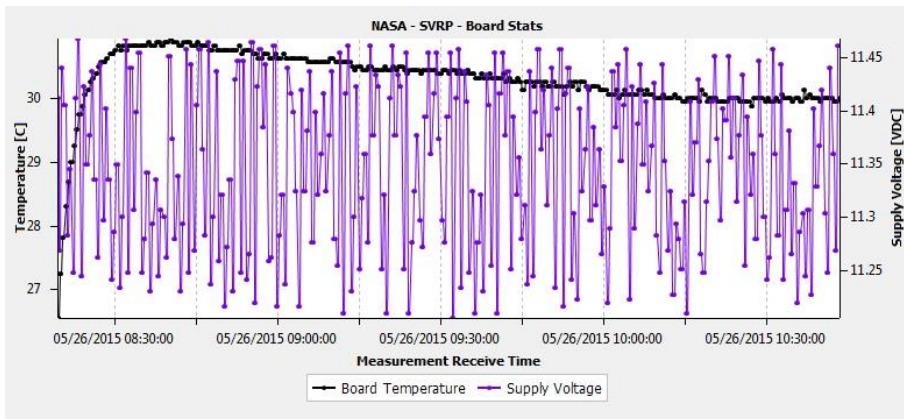
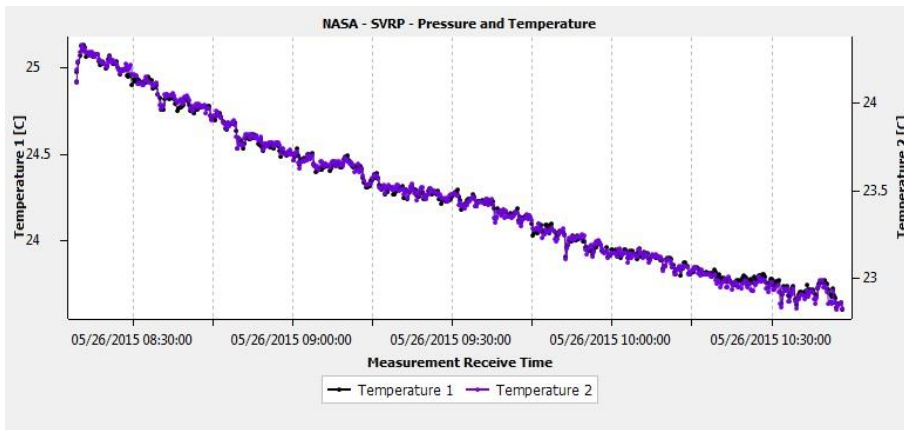

## Passive System

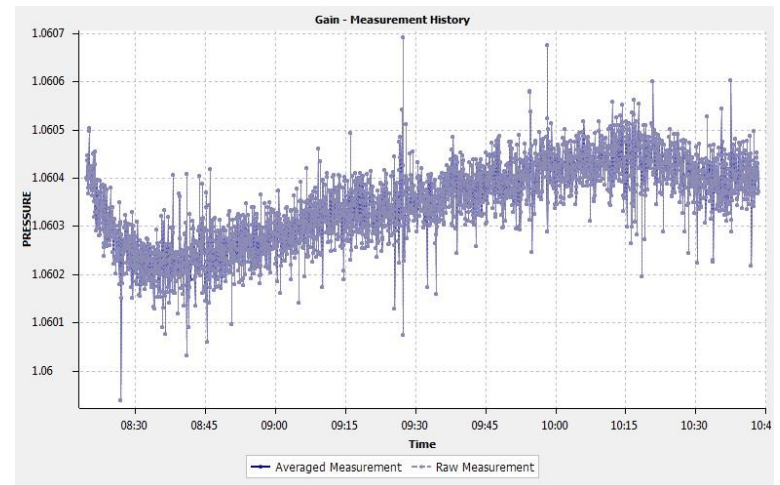
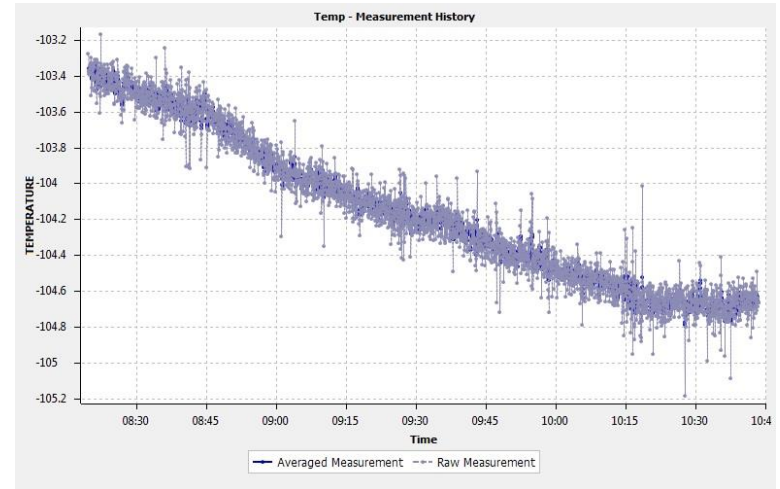

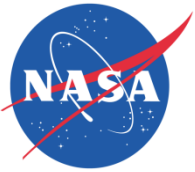

# Conclusion

- Active System performance was unaffected by the LN testing and gave accurate readings down to the LN temperature.
- Active system requires internal electronics to be insulated and heated to maintain -70C or higher temperature, but operated down to -140C without insulation or heating
- Active system, when below operating temperature, failed to a known value, so a failure can be detected and invalid data ignored
- Passive System readings became inaccurate below -175C and a large offset was present in post LN testing.
- Passive system is has a much lower signal to noise ratio and is affected by movement of metal near the system.
- Active system is more resilient and reliable. Further development of this system is planned for 2016.



# Future Plans

- A second Marshall Study has been funded for 2016. The focus will be on a Wiψ system that has a path to flight.
  - Increasing Data Rate
  - Reducing Size and Weight (sacrificing efficiency)
  - Improving electronics insulation
  - Use SLS sensors
- We plan to test down to Liquid Hydrogen temperatures using a mixture of Liquid Nitrogen and Liquid Helium