

Science & Technology Office  
ZP22

**X-ray & Cryogenic Facility  
(XRCF)  
Handbook**

APPROVAL

Name

\_\_\_\_\_  
Original signed by Jeff Kegley

Title

XRCF Manager

Org

ZP22

Date

3/10/16

<b>Marshall Space Flight Center X-ray and Cryogenic Facility</b>		
<b>Title- XRCF Handbook</b>	<b>HNBK-FA-XRC-650</b>	<b>Baseline</b>
	<b>Date: March 10, 2016</b>	<b>Page 2 of 32</b>

**DOCUMENT HISTORY LOG**

<b>Status (Baseline/ Revision/ Canceled)</b>	<b>Document Revision</b>	<b>Effective Date</b>	<b>Description</b>
Baseline		3/10/2016	Initial Release

Marshall Space Flight Center X-ray and Cryogenic Facility		
Title- XRCF Handbook	HNBK-FA-XRC-650	Baseline
	Date: March 10, 2016	Page 3 of 32

## XRCF HANDBOOK

### 1. INTRODUCTION

#### 1.1 Purpose

The *X-ray & Cryogenic Facility (XRCF) Handbook* is a guide for planning operations at the facility. A summary of the capabilities, policies, and procedures is provided to enhance project coordination between the facility user and XRCF personnel. This handbook includes basic information that will enable the XRCF to effectively plan and support test activities. In addition, this handbook describes the facilities and systems available at the XRCF for supporting test operations.

#### 1.2 General Facility Description

The XRCF was built in 1989 to meet the stringent requirements associated with calibration of X-ray optics, instruments, and telescopes and was subsequently modified in 1999 & 2005 to perform the challenging cryogenic verification of Ultraviolet, Optical, and Infrared mirrors. These unique and premier specialty capabilities, coupled with its ability to meet multiple generic thermal vacuum test requirements for large payloads, make the XRCF the most versatile and adaptable space environmental test facility in the Agency. XRCF is also recognized as the newest, most cost effective, most highly utilized facility in the portfolio and as one of only five NASA facilities having unique capabilities.

The XRCF is capable of supporting and has supported missions during all phases from technology development to flight verification. Programs/projects that have benefited from XRCF include Chandra, Solar X-ray Imager, Hinode, and James Webb Space Telescope. All test programs have been completed on-schedule and within budget and have experienced no delays due to facility readiness or failures. XRCF is currently supporting Strategic Astrophysics Technology Development for Cosmic Origins.

Throughout the years, XRCF has partnered with and continues to maintain positive working relationships with organizations such as ATK, Ball Aerospace, Northrop Grumman Aerospace, Excelis (formerly Kodak/ITT), Smithsonian Astrophysical Observatory, Goddard Space Flight Center, University of Alabama Huntsville, and more.

<b>Marshall Space Flight Center X-ray and Cryogenic Facility</b>		
<b>Title-</b> XRCF Handbook	<b>HNBK-FA-XRC-650</b>	<b>Baseline</b>
	<b>Date: March 10, 2016</b>	<b>Page 4 of 32</b>

**Aerial View**



**Location**



NASA, Marshall Space Flight Center  
 X-ray & Cryogenic Test Facility – Building 4718  
 Redstone Arsenal  
 Huntsville, AL 35812

<b>Marshall Space Flight Center X-ray and Cryogenic Facility</b>		
<b>Title-</b> XRCF Handbook	<b>HNBK-FA-XRC-650</b>	<b>Baseline</b>
	<b>Date: March 10, 2016</b>	<b>Page 5 of 32</b>

## **OPERATIONAL HISTORY**

### **X-ray Optics/Telescopes History**

- Original XRCF construction in mid 1970s for HEAO-B
- Rebuilt for Chandra X-ray Observatory (AXAF) from 1989-1991
- Chandra Calibration completed in 1997
- Other x-ray telescopes testing (SXI series, Hinode) from 1997-2005

### **Cryogenic/Cryo-Optical History**

- Cryo-optical test modifications for Next Generation Mirror System Demonstrator (NMSD) in 1999
- NMSD / SBMD tests performed 1999 - 2002
- Cryo-optical test modifications - Small cryo-chamber commissioned in 2001
- Advance Mirror System Demonstrator (AMSD) performed in 2003
- Modified for James Webb Space Telescope (JWST) in 2005
- JWST Backplane Structure advanced to Technology Readiness Level 6 in 2006
- JWST Integrated Science Instrument Module design validation in 2007
- Primary Mirror Segment Assemblies (PMSAs) verified from 2008 – 2011
- JWST Center of Curvature Optical Assembly (CoCOA) functionally tested in 2012
- JWST Backplane Structure Critical Interface Points verified in 2013

<b>Marshall Space Flight Center X-ray and Cryogenic Facility</b>		
<b>Title-</b> XRCF Handbook	<b>HNBK-FA-XRC-650</b>	<b>Baseline</b>
	<b>Date: March 10, 2016</b>	<b>Page 6 of 32</b>

## Quick-Look Salient Features

<p><b>Specialty Capabilities:</b></p> <ul style="list-style-type: none"> <li>• X-ray calibration and performance testing of large, grazing-incidence x-ray optics, detectors, and telescopes</li> <li>• Cryogenic (&lt; -400F) optical metrology of large direct-incidence optics and structures (<math>\pm 1 \mu</math>radian line of sight stability)</li> </ul> <p><b>Vacuum Volumes:</b></p> <ul style="list-style-type: none"> <li>• 20ft dia x 60ft horizontal cylindrical test volume</li> <li>• 5ft dia x 1728ft illumination beam line</li> </ul> <p><b>Vacuum Levels:</b></p> <ul style="list-style-type: none"> <li>• <math>10^{-8}</math> Torr via cryogenic and turbomolecular pumps</li> <li>• <math>10^{-3}</math> Torr helium partial pressure to augment heat transfer</li> </ul> <p><b>Thermal Environments:</b></p> <ul style="list-style-type: none"> <li>• Entire test volume from -200F to +200F (55 zones)</li> <li>• Two enclosures from -424F to +120F <ul style="list-style-type: none"> <li>– 10ft x 8ft x 30ft</li> <li>– 31ft x 16.5ft dia</li> </ul> </li> </ul> <p><b>Clean Rooms:</b></p> <ul style="list-style-type: none"> <li>• 6000 sq ft Class 1,000 (ISO 6)</li> <li>• 2000 sq ft Class 10,000 (ISO 7)</li> </ul>	<p><b>Helium Refrigeration</b></p> <ul style="list-style-type: none"> <li>• Two closed-loop gaseous helium expansion cycle refrigerators each capable of 1kW at 20K</li> </ul> <p><b>X-ray Generators:</b></p> <ul style="list-style-type: none"> <li>• Energy range from 0.1 to 10 keV</li> <li>• Other ranges available at MSFC</li> </ul> <p><b>Optical Metrology</b></p> <ul style="list-style-type: none"> <li>• Leica laser Absolute Distance Meter</li> <li>• 4D PhaseCam, AOA Wavescope, IPI</li> </ul> <p><b>Optical View Port</b></p> <ul style="list-style-type: none"> <li>• 10.8 inch dia clear aperture N-BK-7 tiltable window</li> </ul> <p><b>Metrology Alignment Stages</b></p> <ul style="list-style-type: none"> <li>• Physik Instrumente Hexapod precision motion stage</li> <li>• Aerotech XYZ translation stage</li> </ul> <p><b>Test Article Alignment Stages</b></p> <ul style="list-style-type: none"> <li>• 6 Degree of Freedom Stage – cryogenic and vacuum capable</li> <li>• Five Axis Mount – vacuum capable</li> </ul>
---	---

<b>Marshall Space Flight Center X-ray and Cryogenic Facility</b>		
<b>Title-</b> XRCF Handbook	<b>HNBK-FA-XRC-650</b>	<b>Baseline</b>
	<b>Date: March 10, 2016</b>	<b>Page 7 of 32</b>

### 1.3 X-ray Test Capability

The x-ray source system, used to simulate emissions from distant celestial objects, is located on the west end of the 518+ meter x-ray guide tube. The source system produces a 1.46 meter diameter x-ray beam at the chamber entrance. X-ray detectors 120 feet downrange from the source monitor the x-ray beam and provide feedback to the x-ray generator. An adjustable optical mount on a moveable stage at the instrument chamber entrance maps the incoming x-ray beam. Focal plane detectors also are mounted on motion stages, allowing them to be moved in or out of focus and/or to scan across the x-ray image. An array of pinholes and slits can be remotely inserted between the detectors and the mirror under test to redirect x-ray beams as needed. More than 20 x-ray mirror, instrument and telescope calibrations have been completed since 1991, including Chandra, five Solar X-ray Imagers for a series of National Oceanic and Atmospheric Administration meteorological satellites, and Hinode's X-ray Telescope — a project that is exploring the magnetic fields of the sun.



- 518.2m long stainless steel  $10^{-7}$  Torr vacuum vessel
- Guide tube section dimensions
  - 1.52m diameter x 112.8m
  - 1.22m diameter x 100.6m
  - 0.91m diameter x 304.8m
- Mates to chamber through 1.52m diameter vacuum gate valve
- Baffles to control X-ray scatter – allows 1.46m diameter unvignetted x-ray test beam at chamber entrance
- X-ray flux monitors located 37.4m from x-ray sources in flux monitor building
- Cryogenic pumps

<b>Marshall Space Flight Center X-ray and Cryogenic Facility</b>		
<b>Title-</b> XRCF Handbook	<b>HNBK-FA-XRC-650</b>	<b>Baseline</b>
	Date: March 10, 2016	Page 8 of 32

#### 1.4 Cryogenic & Optical Test Capability

The X-ray and Cryogenic Facility is equipped with helium-cooled enclosures capable of providing stable test conditions ranging from ambient to less than minus 424 F (20 Kelvin). Two each 1kW helium refrigerators cool the enclosure by expansion of pre-cooled helium gas. The inside of the enclosure has provisions to hold a test article that is isolated from the vibration of the enclosure walls and the chamber ( $\pm 1 \mu$ radian line of sight). The facility has a variety of enclosures that can be plumbed to the refrigerators for multiple configurations. Temperature set points can be controlled in 0.1 Kelvin increments from 300 to < 20 Kelvin.

Optics as large as 13.12 feet (4 meters) in diameter can be tested at the XRCF. Two interferometers, instruments for optically measuring structural distortions that occur during cryogenic testing of telescope mirrors, are available which offer fast, quantitative surface figure measurement that is relatively insensitive to the effects of vibration. More than 30 cryogenic test operations have been completed since 1999 — most in development or direct support of the James Webb Space Telescope. The JWST cryo-optical test configuration is shown below.

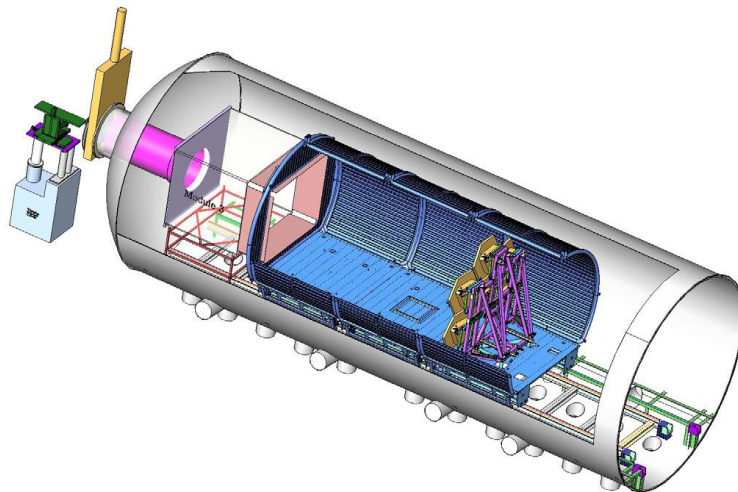
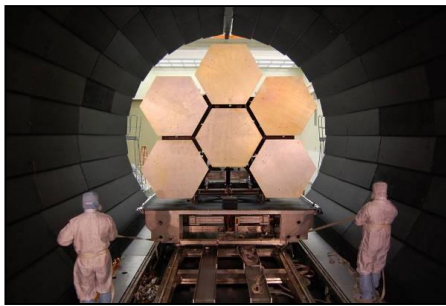
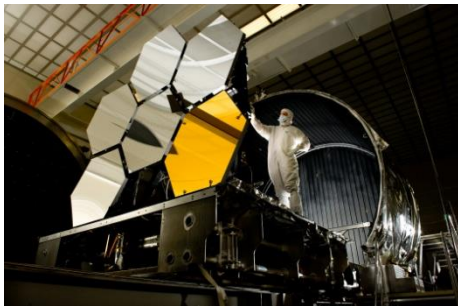



<b>Marshall Space Flight Center X-ray and Cryogenic Facility</b>		
<b>Title-</b> XRCF Handbook	<b>HNBK-FA-XRC-650</b>	<b>Baseline</b>
	<b>Date: March 10, 2016</b>	<b>Page 9 of 32</b>

### 1.5 Additional Capabilities

In addition to the large vacuum chamber, the facility has a smaller cryogenic optical testing chamber. The helium-cooled test volume in the small chamber is a horizontal cylinder 40 inches in diameter and 88 inches deep. This chamber achieves test pressures and temperatures comparable to those of the large chamber in approximately one-tenth of the time. It uses control and data acquisition systems similar to those of the larger chamber and accommodates the same interferometer systems. More than 30 cryogenic test operations have been completed in the small chamber since it was commissioned in 2001.



Hardware pre-conditioning is also possible in a 4' diameter x 8' long horizontal cylinder equipped with lamps and a cold plate. This chamber is used for time and temperature bake-outs (up to ~ 300 deg F) to ensure contamination control requirements can be satisfied.

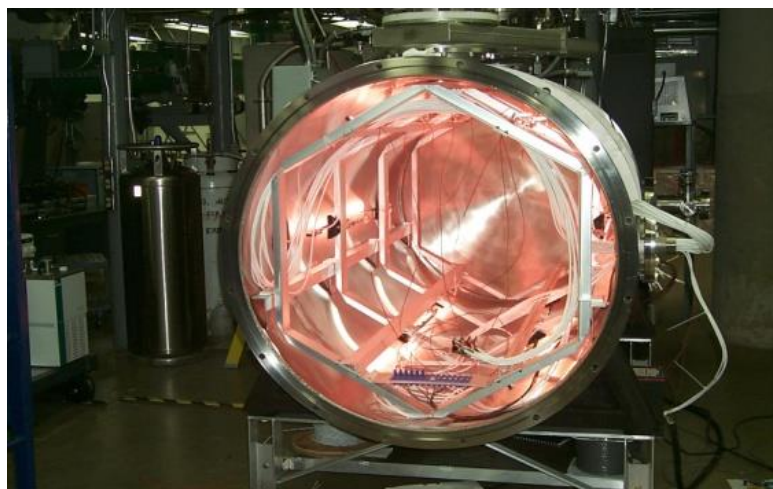

<b>Marshall Space Flight Center X-ray and Cryogenic Facility</b>		
<b>Title-</b> XRCF Handbook	<b>HNBK-FA-XRC-650</b>	<b>Baseline</b>
	<b>Date: March 10, 2016</b>	<b>Page 10 of 32</b>

## **2. APPLICABLE DOCUMENTS**

Revision levels of documents are not shown. The latest revision shall be used unless otherwise required by contractual requirements or other regulations. In this case the revision letter of the document shall be given.

MPD 1280.1 Marshall Management Manual  
MPR-1050.1 Agreement Selection Process  
MPR-1280.4 Corrective Action System  
MPR-1440.2 MSFC Records Management Program  
MPR-3410.1 Training  
MPR-4000.1 Control of Customer Supplied Product  
MPR-8715.1 Marshall Safety, Health, and Environmental Program  
MPR-8730.1 Inspection and Testing  
MPR-8730.3 Control of Nonconforming Product  
MPR-8730.5 Control of Inspection, Measuring and Test Equipment  
MSFC-RQMT Requirements for Electrostatic Discharge Control -2918  
MWI-6410.1 Packaging, Handling, and Moving Program Critical Hardware (PCH)  
MWI-6430.1 Lifting Equipment & Operations  
MWI-3410.1 Personnel Certification  
MWI-8621.1 Mishap and Close Call Reporting and Investigation Program  
MWI-8715.2 Lockout/Tagout Program  
MWI 8715.15 Ground Operations Safety Assessment Program  
NASA-STD-8719.9 Standard For Lifting Devices and Equipment  
MPR 6410.1 Handling, Storage, Packaging, Preservation, and Delivery (HSPPD)  
NPR 1441.1 NASA Procedural Requirements/NASA Records Retention Schedules  
SMS-OI-VP01.2 Authorization and Control of OI's

<b>Marshall Space Flight Center X-ray and Cryogenic Facility</b>		
<b>Title-</b> XRCF Handbook	<b>HNBK-FA-XRC-650</b>	<b>Baseline</b>
	<b>Date: March 10, 2016</b>	<b>Page 11 of 32</b>

### 3. FACILITY SYSTEMS

<b>Primary Facility Systems</b>
High Vacuum – Cryopumps High Vacuum – Turbopumps Facility Control Vacuum Instrumentation Data Acquisition Helium Refrigeration Helium Cooled Enclosures LN2 Cooled Forward Intercept Helium Injection

#### 3.1 High Vacuum – Cryopumps

The XRCF vacuum chamber and x-ray tube are equipped with six each CVI Torrmaster TM500 valved cryogenic high vacuum pumps. These pumps, which are inherently clean since they operate as capture pumps, are used for evacuation from  $25 \times 10^{-3}$  Torr to high vacuum. In addition, the chamber is equipped with four each 60 inch diameter unvalved cryogenic pumps providing additional pumping speed when necessary. The x-ray tube is also equipped with sixteen each CVI Torrmaster TM450 cryogenic pumps spaced along the length of the tube.

#### 3.2 High Vacuum – Turbopumps

Two Osaka TG2000M turbomolecular / molecular drag hybrid high vacuum pumps are installed on the XRCF vacuum chamber with their primary function being the evacuation of helium.

#### 3.3 Facility Control

Programmable Logic Controller (PLC) based network allows monitoring and control of remote facility systems. Embedded PLC ladder logic provides interlocks to prevent undesired facility operational conditions, ensures fail safe operation of remote systems, and allows safe shutdown of pumps, valves, and other facility hardware.

<b>Marshall Space Flight Center X-ray and Cryogenic Facility</b>		
<b>Title-</b> XRCF Handbook	<b>HNBK-FA-XRC-650</b>	<b>Baseline</b>
	<b>Date: March 10, 2016</b>	<b>Page 12 of 32</b>

### **3.4 Vacuum Instrumentation**

Several types of pressure gauges are utilized for the instrument chamber and x-ray tube. Ambient pressure down to  $10^{-4}$  Torr is monitored largely with Granville Phillips Convectron® gauges. A MKS capacitance manometer provides feedback for repressurization control from  $10^{-2}$  Torr to ambient. MKS Spinning rotor and cold cathode gauges as well as Granville Phillips Stabil-Ion® gauges provide for high vacuum readings and interlocks. Corona interlocks are provided by a Convectron® gauge at 20 Torr and a Stabil-Ion® gauge at  $5 \times 10^{-4}$  Torr.

### **3.5 Data Acquisition**

Data acquisition server computers and associated client machines acquire facility data, provide real-time client displays, and archive facility system data to disk. Alarm conditions are monitored, and audible control room alerts along with alphanumeric pages are generated.

### **3.6 Helium Refrigeration**

The twin XRCF Cryogenic Cooling Systems are closed-loop gaseous helium expansion cycle refrigeration systems each with a capacity of 1 kW at 20 Kelvin. A compressor provides helium at 250 psig to the heat exchangers and expansion cycle refrigerator. The expanded cold gas (< 15 psig) flows through the helium-cooled enclosure in the chamber and returns to the refrigerator where it is warmed before returning to the compressor at ambient temperature.

### **3.7 Helium Cooled Enclosures**

Helium cooled enclosures can provide the thermal environment for a test article. Enclosures are cooled via the helium refrigeration systems from ambient to minus 414 F (25 Kelvin). A variety of enclosure configurations are possible to support specific test requirements.

### **3.8 LN<sub>2</sub> Cooled Forward Intercept**

A liquid nitrogen-cooled cylinder serves as an extension from helium cooled enclosure to the aperture. The cylinder “intercepts” heat from chamber wall that would be incident upon the inside of the helium cooled enclosure while actively cooling the area around the aperture.

### **3.9 Helium Injection**

A mass flow controller is used to bleed small amounts of Grade 5 bottled helium gas into the chamber vacuum to augment heat transfer from test article – usually at temperatures below 100K.

Marshall Space Flight Center X-ray and Cryogenic Facility		
Title- XRCF Handbook	HNBK-FA-XRC-650	Baseline
	Date: March 10, 2016	Page 13 of 32

Supporting Systems
HPA GN2 LN2 Cooling Water Regeneration Vacuum Chamber Thermal Control Facility Power HVAC Rough Vacuum

### 3.10 High Purity Air (HPA)

Cross-country HPA provides the following: (1) actuation / control air to all remote actuated facility valves (2) actuation air to chamber dome & manway clamps, (3) actuation air to chamber room monorail hoist switch, and (4) various use points in the clean rooms.

### 3.11 Gaseous Nitrogen System (GN<sub>2</sub>)

Cross-country GN<sub>2</sub> provides the following: (1) purge gas to Rough Vacuum System, (2) purge gas to chamber LN<sub>2</sub> cryogenic panels, (3) regeneration purge gas to cryogenic vacuum pumps, (4) pressurant gas to LN<sub>2</sub> Storage Tanks, and (5) various use points in the clean rooms.

### 3.12 Liquid Nitrogen System (LN<sub>2</sub>)

Locally stored LN<sub>2</sub> (56,000 gallon capacity) is used for the following: (1) contamination control during rough vacuum operations and chamber high vacuum operations (2) thermal control assistance (chamber shroud and LN<sub>2</sub>-cooled forward intercept) and (3) helium refrigerator heat exchanger operation.

### 3.13 Cooling Water

Cooling water is supplied to remove heat of compression from rough vacuum pumps, cryogenic pumps, and helium compressors via potable and chilled water systems.

### 3.14 Regeneration Vacuum

Oil-free vacuum pumps are used to regenerate valved cryogenic pumps.

### 3.15 Chamber Thermal Control

The chamber thermal control system provides positive thermal control of the primary chamber test volume (outside the helium-cooled enclosure) from -200F to +200F. The system consists of resistive strip heaters bonded to aluminum plates and grouped into 55 individually controllable zones producing a uniform and stable thermal environment in the 20ft dia x 60ft test volume.

<b>Marshall Space Flight Center X-ray and Cryogenic Facility</b>		
<b>Title-</b> XRCF Handbook	<b>HNBK-FA-XRC-650</b>	<b>Baseline</b>
	<b>Date: March 10, 2016</b>	<b>Page 14 of 32</b>

### **3.16 Facility Power**

Two main power distribution feeds supply the XRCF main building. Power from Switch Board A (SB-A) is distributed throughout most of the facility with the exception of the clean room. An 800 KW generator supports the operation of loads from SB-A. A 50 KVA Uninterruptible Power Supply (UPS) is also fed from SB-A to critical loads. Once the backup generator comes online, UPS batteries begin to recharge and operations continue as if normal power is provided. Power is distributed through Switch Board B (SB-B) for the clean room and supporting systems. Circuits attached to SB-B have no built-in backup power.

### **3.17 Heating, Ventilation, and Air Conditioning (HVAC)**

The HVAC systems provide heating, cooling, pressure, and humidity control in non-critical areas. Critical areas such as the clean rooms and metrology areas are supplied by the same type of environmental control system, but additional sensors and alarms are installed to ensure critical conditions are monitored and maintained.

### **3.18 Rough Vacuum**

Seven Stokes 1722 Rough Vacuum pump systems are used to evacuate the chamber and x-ray tube from 760 Torr to  $25 \times 10^{-3}$  Torr. Four of these pumps serve the chamber and/or the x-ray tube; three are dedicated to the x-ray tube. These systems incorporate redundant liquid nitrogen cold traps to prevent pump oil migration to the chamber and x-ray tube.

<b>Marshall Space Flight Center X-ray and Cryogenic Facility</b>		
<b>Title-</b> XRCF Handbook	<b>HNBK-FA-XRC-650</b>	<b>Baseline</b>
	<b>Date: March 10, 2016</b>	<b>Page 15 of 32</b>

<b>Test Support Equipment / Systems</b>
Optical Test System Test Article Motion Stages Clean Rooms Contamination Control & Monitoring X-ray Source System X-ray Detector System

### **3.19 Optical Test System**

Two vibration isolated piers are available for mounting optical metrology, which may include motion stages and optical test equipment. A clean tent with fans to circulate air can be positioned around the metrology test area. The floor load capacity is approximately 40 lbs/ft<sup>2</sup> (office space floor loading specification). As a general rule, no more than four people should enter the area.

The following hoists for hardware handling are available for OTS hardware installation:

- 1) 2000 lb monorail hoist on second floor – moves hardware from first to second floor through a 77"X54" opening and transports hardware on second floor and
- 2) 6000 lb gantry crane with two 3000 lb hoists (manual & electric) which is used to install hardware in the metrology test area.

A tilt window with the following specifications is installed on the facility optical axis to provide a view of the test article:

- Material: Schott N-BK-7,
- Glass Dimensions: 12" diameter x 1.7" thick
- Clear Aperture Diameter: 10.8"
- Coating: Atmosphere side - AR coated, Vacuum side - Gold coated
- Tilt Capability: ±6° in both pitch & yaw

Two smaller, off-axis windows are also in place for use during testing.

- Material: Fused Silica
- Glass Dimension: 6" diameter x 0.37" thick
- Clear Aperture Diameter: 5.38"
- Coating: Atmosphere & Vacuum sides - AR coated

<b>Marshall Space Flight Center X-ray and Cryogenic Facility</b>		
<b>Title-</b> XRCF Handbook	<b>HNBK-FA-XRC-650</b>	<b>Baseline</b>
	<b>Date: March 10, 2016</b>	<b>Page 16 of 32</b>

Facility provided motion stages can be utilized to support optical metrology in the test area.

The following stages are available:

- (1) Physik Instrumente (PI) M-850K036 Hexapod, 6 degree of freedom precision stage
  - Range (lateral/vertical):  $\pm 50$  mm/ $\pm 25$  mm
  - Range (roll & pitch/yaw):  $\pm 15^\circ/\pm 30^\circ$
  - Min Step Size (lateral/vertical): 1  $\mu$ m/0.5  $\mu$ m
  - Min Step Size (angular): 5  $\mu$ rad (1 arc-sec)
  - Repeatability (lateral/vertical): 2  $\mu$ m/1  $\mu$ m
  - Repeatability (angular): 10  $\mu$ rad (2 arc-sec)
  - Load:  $\leq 200$  kg
- (2) Aerotech XYZ Stages
  - Range:  $\pm 150$  mm
  - Resolution: 0.02  $\mu$ m
  - Min Step Size: 0.2  $\mu$ m
  - Accuracy: 5  $\mu$ m
  - Load:  $\leq 158$  kg

The following facility provided optical metrology equipment is available:

- (1) 4D PhaseCam Interferometer
- (2) AOA Wavescope
- (3) ADE PhaseShift Instantaneous PhaseShifting Interferometer
- (4) Leica Absolute Distance Meter

### **3.20 Test Article Motion Stages**

Precision motion, angular and translation, is provided by two motion stages.

- (1) 6 Degree of Freedom Motion Stage – acceptable for use at cryogenic temperatures
  - Range (focus/ transverse & vertical):  $\pm 25.4$  mm/ $\pm 21.6$  mm
  - Range (roll/pitch & yaw):  $\pm 2^\circ/\pm 3^\circ$
  - Resolution (focus, transverse & vertical):  $\pm 0.00254$  mm
  - Resolution (roll, pitch, & yaw): 1 arc-sec
  - Load:  $\leq 1270$  kg
- (2) Five Axis Mount – not equipped to support cryogenic operation
  - Range (focus/ transverse/vertical):  $\pm 123$ mm/ $\pm 158$ mm/ $\pm 160$ mm
  - Range (roll/pitch & yaw):  $\pm 1.5^\circ/\pm 9^\circ$
  - Resolution (focus, transverse & vertical):  $\pm 0.0005$  mm
  - Resolution (roll, pitch, & yaw): .5 arc-sec
  - Load:  $\leq 1000$  kg



<b>Marshall Space Flight Center X-ray and Cryogenic Facility</b>		
<b>Title-</b> XRCF Handbook	<b>HNBK-FA-XRC-650</b>	<b>Baseline</b>
	<b>Date: March 10, 2016</b>	<b>Page 17 of 32</b>

### **3.21 Clean Rooms**

Clean rooms provide temperature, humidity, pressure, and particle control. Critical clean rooms include the Receiving Clean Room – Class 10K, the Instrument Chamber Clean Room – Class 1K, and the Equipment Clean-up Area – Class 10K.

### **3.22 Contamination Control & Monitoring**

Control and monitoring of vacuum system cleanliness is critical for facility operations. Controls include preconditioning hardware, material evaluation/testing, use of an LN2 getter panel, and controlled repress rates. Monitoring in a vacuum environment can include active or passive plates or wafers, TQCMs, CQCMs, and RGAs. Portable particle counters for non-vacuum applications are also available.

### **3.23 X-ray Source System**

The x-ray source system is located on the end of the x-ray guide tube 518m from the vacuum chamber and consists of a Point Electron Impact Source, a Penning Gas Discharge Source, two Rotating Anode Sources (RAS), a High Resolution Erect Field Spectrometer (HiREFS), and a Double Crystal Monochromator (DCM). The Point Electron Impact Source impinges an electron beam on a pure or composite metal producing x-ray energies dependent upon the target metal used. The Penning Gas Discharge Source utilizes ionized argon with aluminum cathodes to produce x-rays. The RAS are similar to the Point Electron Impact Source. The HiREFS uses two concave mirrors to focus and tune the x-ray beam from a source. The DCM uses two crystals to magnify RAS x-rays. Each x-ray source has its own vacuum system and is mounted on a translation table for movement into the test position on the facility optical axis. All sources produce different fluxes over different energy ranges. Energies from 0.1 to 10 keV and fluxes from 1 to 10<sup>14</sup> photons/second/cm<sup>2</sup> can be produced. Combinations of filters can be remotely inserted into the x-ray beam just “downstream” of the source to further discriminate the x-rays reaching the mirror under test. The x-ray source system generates a 1.46m (57.5”) diameter unvignetted beam at the chamber entrance.

### **3.24 X-ray Detector System**

The x-ray detector system is comprised of x-ray instrumentation located near the x-ray source, at the entrance to the chamber, and at the focal plane. Flow Proportional Counters (FPCs) and a Solid State Detector (SSD) near the x-ray source can be used to monitor the x-ray beam and provide feedback to the x-ray generator. An FPC mounted on a 2-D translation stage located at the entrance to the chamber is used to map the incoming x-ray beam. Detectors in the focal plane include FPCs, an SSD, a High Speed Imager, and a CCD. These instruments are mounted on motion stages to allow them to be moved in/out of focus and/or scan across the x-ray image. An array of pinholes and slits can be remotely inserted into the focal plane between the FPCs and the mirror under test.

<b>Marshall Space Flight Center X-ray and Cryogenic Facility</b>		
<b>Title-</b> XRCF Handbook	HNBK-FA-XRC-650	<b>Baseline</b>
	<b>Date:</b> March 10, 2016	<b>Page 18 of 32</b>

## 4. POLICIES & REQUIREMENTS

### 4.1 Safety and Mission Assurance

All test activities will be conducted in accordance with safety policy and criteria established in MPR-8715.1D, Marshall Safety, Health, and Environmental Program. S&MA personnel will support test operations as required to provide the following: (1) summary safety assessment of test activities (2) hazard analysis or job hazard analysis (JHA) which identifies all risks and hazards to test article, test facility, or personnel and (3) summary of hazard mitigation and/or control measures for the acceptability of residual risk.

### 4.2 Test Operations

Test requests may be received from the project manager, project engineer, a representative from another organization within the Science & Technology Office, or an external organization. A determination is made regarding the capability and resources available within the organization to perform the proposed test. If it is determined that test performance is not feasible due to lack of capability or resources, the test request is denied and reasons explained to management and to the potential customer.

Agreements with groups outside MSFC include Cooperative Agreements, Space Act Agreements, Non-reimbursable Agreements, Reimbursable Agreements, Intra-Agency Agreements, and Inter-Agency Agreements. Customer Agreements internal to MSFC include Center Task Agreements, and Collaborative Work Commitments (CWC). A memorandum which includes a clear understanding of the basic test requirements may be used to document simple tests.

After an agreement is established with the customer, an XRCF test director shall be assigned by the XRCF Manager. The test director and supporting team are responsible for reviewing all available project documentation, including but not limited to verification plans, end item specifications, science requirements, hazard analysis, ground support equipment, and instrument interface agreements. This information shall be utilized to compile a full set of test requirements. The test director shall identify a series of tests which will fulfill all customer requirements and shall identify all responsible persons for coordinating any required ground support equipment, special test equipment, and facility modifications.

A test readiness review (TRR) shall be conducted for each test. The TRRs level of detail shall be determined by Test Director and project representative.

#### Criteria for Demonstrating an Acceptable Level of Test Readiness

- Test Objectives and Test Requirements
  - Assure test objectives and requirements have been clearly defined and documented

<b>Marshall Space Flight Center X-ray and Cryogenic Facility</b>		
<b>Title-</b> XRCF Handbook	HNBK-FA-XRC-650	<b>Baseline</b>
	Date: March 10, 2016	Page 19 of 32

- Verify test matrix, test conditions, and expected test results have been defined
- Test Article Configuration
  - Assess the as-built vs. as-designed configuration of test article
  - Review any waivers or deviations to assure that test article configuration is appropriate to meet test requirements.
- Test Procedures and Documentation
  - Determine the status of test operation procedures and related test preparation and facility activation documentation
  - Assure that test procedures have been properly reviewed and approved
- Test Facility Configuration and Activation
  - Assure that test facility, Special Test Equipment (STE), and other supporting systems and equipment has been reviewed against documented requirements
  - Verify that the test facility and STE configuration is adequate to meet test requirements
- Test Team Personnel Certification and Training
  - Review test team staffing and any special personnel qualification and certification requirements to assure that full complement of certified test team personnel will be available to support test operations
- Hazard Analysis
  - Review summary of hazard analysis or JHA to assure that appropriate controls have been implemented to mitigate risk to an acceptable level
  - Assure that S&MA has assessed mitigating controls for adequacy and acceptability.
- Test Redlines, Operational Parameter, Limits, and Controls
  - Review redlines, operational parameters, and test control limits to assure that proper limits have been defined and implemented to safely control test operations and prevent unacceptable risk to test article
  - Review and assess shutdown modes and sequences for adequacy.
- Open Work and Constraints
  - Review status of all remaining open work including any actions imposed by previous boards or committees
  - Assure that adequate procedures are in place to ensure closure of all test constraining open work before start of test operations

### **4.3 Scheduling**

The XRCF Test Director is responsible for establishing and maintaining a schedule of test activities. This responsibility includes publishing schedules and summaries while resolving scheduling conflicts between project requirements and resources. Every effort is made to resolve conflicts between programs in a manner that permits each program to be successfully completed on an acceptable schedule.

<b>Marshall Space Flight Center X-ray and Cryogenic Facility</b>		
<b>Title-</b> XRCF Handbook	HNBK-FA-XRC-650	<b>Baseline</b>
	<b>Date:</b> March 10, 2016	<b>Page 20 of 32</b>

## **5. ADMINISTRATION & LOGISTICS**

### **5.1 Access**

Marshall Space Flight Center (MSFC) maintains 24-hour security for all facilities. Personnel who do not possess a current NASA security badge must be entered into the Visitor Management System (VMS) to obtain center access. Visits to the XRCF must be coordinated with test personnel to enter the facility via keycard.

### **5.2 Working Hours**

The normal workday for XRCF is 0700 to 1530 Monday through Friday. Coordination of the work schedule with the Test Director is necessary to ensure access to required facilities and the availability of necessary technical personnel and resources. Support outside of the normal workday is often required for test activities, and XRCF personnel routinely work long days, nights, and weekends, if required.

### **5.3 Cafeteria**

Marshall Space Flight Center (MSFC) manages cafeteria services in Buildings 4203 and 4708 at the following times: Breakfast: 7-10 a.m. - Lunch main line: 11 a.m. - 1 p.m. - Grill: 11 a.m. – 1:30 p.m.

### **5.4 Communication Services**

Telephone and fax service is available. There are no restrictions on pagers and cell phones. The Agency Consolidated End-User Services (ACES) contractor can provide Internet access via an ACES provided machine (with associated cost) or a wireless Guest Network connection (at no cost). Non-ACES full internet access would require going through the entire NASA computer IT security process with the sponsor vouching for any individual using the machine. The XRCF is equipped with wireless network coverage.

### **5.5 Industrial Safety**

Industrial safety procedures are typical of those enforced at other U.S. Government facilities. In addition, personnel are expected to obey all control signals and roadblocks.

### **5.6 Fire Protection**

Fully trained firefighters man the fire stations 24 hours a day. Emergency medical technicians are also available on-site from 0700-1700 on normal work day hours.

### **5.7 Medical Facilities**

A medical center is available for limited medical services in the event of an emergency during working hours. Emergency medical technicians and ambulance services are also available for transportation to a local hospital.

<b>Marshall Space Flight Center X-ray and Cryogenic Facility</b>		
<b>Title-</b> XRCF Handbook	HNBK-FA-XRC-650	<b>Baseline</b>
	<b>Date:</b> March 10, 2016	<b>Page 21 of 32</b>

## 5.8 Shipping and Receiving

Various shipping services, including United Parcel Service and Federal Express have access to MSFC for pickup and delivery at Building 4631 (Central Receiving). The XRCF user should use the following information when mailing correspondence or shipping equipment for official project business:

Mail Address:  
Name/MSFC Mail Code (ZP22)  
NASA Marshall Space Flight Center  
Huntsville, AL 35812

Freight Destination Address:  
Name/ MSFC Mail Code (ZP22)  
Building 4631 Central Receiving  
NASA Marshall Space Flight Center  
Huntsville, AL 35812

Over-the-road freight truck deliveries are received at MSFC via Gate 1 of Redstone Arsenal. After a truck inspection is performed, deliveries can be made directly to the XRCF. MSFC also has access to marine and air transportation when special delivery considerations are required.

## 5.9 Hazardous Material

All hazardous material must be packaged to conform to applicable Department of Transportation regulations. A Material Safety Data Sheet (MSDS) must accompany all hazardous materials shipped to MSFC. All hazardous materials shall be disposed of in accordance with the center regulations. Radioactive sources require approval from the MSFC Radiation Safety Officer prior to arrival, and the customer must provide the proper forms requesting the use of a radioactive material at MSFC / XRCF, including license information, to the Test Director at least 90 days prior to the shipment/arrival of the source.

<b>Marshall Space Flight Center X-ray and Cryogenic Facility</b>		
<b>Title-</b> XRCF Handbook	<b>HNBK-FA-XRC-650</b>	<b>Baseline</b>
	<b>Date: March 10, 2016</b>	<b>Page 22 of 32</b>

## 5.10 Material Handling Equipment

A variety of material handling and transportation equipment is available. These include forklifts, overhead hoists, and material moving equipment. The XRCF Test Director will work closely with the customer to plan, organize, and execute the handling and movement of hardware.

### XRCF Material Handling Equipment

- 20-ton overhead crane – 2K clean room
- 3-ton overhead crane – 10K clean room
- 20-ton lift platform – Receiving area
- 3-ton overhead crane – 2<sup>nd</sup> floor instrument chamber room (access to 1<sup>st</sup> floor available)
- 3-ton gantry crane – 2<sup>nd</sup> floor instrument chamber room
- 2-ton gantry crane – 1<sup>st</sup> floor instrument chamber room
- Class 5 (3600 lb capacity) propane forklift
- Class 5 (3600 lb capacity) electric forklift – 10K clean room
- Pallet jacks

## 5.11 Contact Information

Facility Manager – Jeff Kegley (256)-544-2291 [jeff.kegley@nasa.gov](mailto:jeff.kegley@nasa.gov)

Electrical & Control Systems – Richard Siler (256)-544-0643 [richard.d.siler@nasa.gov](mailto:richard.d.siler@nasa.gov)

Instrumentation & Data Systems – Ernie Wright (256)-544-8988 [ernie.wright@nasa.gov](mailto:ernie.wright@nasa.gov)

Cryogenic Cooling Shroud – Harlan Haight (256)-544-3064 [harlan.haight@nasa.gov](mailto:harlan.haight@nasa.gov)

<b>Marshall Space Flight Center</b> <b>X-ray and Cryogenic Facility</b>		
<b>Title-</b> <b>XRCF Handbook</b>	<b>HNBK-FA-XRC-650</b>	<b>Baseline</b>
	<b>Date: March 10, 2016</b>	<b>Page 23 of 32</b>

## APPENDIX

**FACILITY LAYOUT / BASIC HARDWARE FLOW**  
**X-RAY GUIDE TUBE DETAILS**  
**CRYOGENIC TEST CONFIGURATION**  
**6 DEGREE-OF-FREEDOM MOTION STAGE**  
**CRYOGENIC ENVIRONMENT INSTRUMENTATION & PLUMBING**  
**MIRROR TEST CAPABILITY**  
**CONTAMINATION CONTROL: MATERIAL SELECTION GUIDELINES**  
**X-RAY SOURCES & DETECTORS**

<b>Marshall Space Flight Center X-ray and Cryogenic Facility</b>		
<b>Title-</b> XRCF Handbook	<b>HNBK-FA-XRC-650</b>	<b>Baseline</b>
	<b>Date:</b> March 10, 2016	<b>Page 24 of 32</b>

**FACILITY LAYOUT / BASIC HARDWARE FLOW**

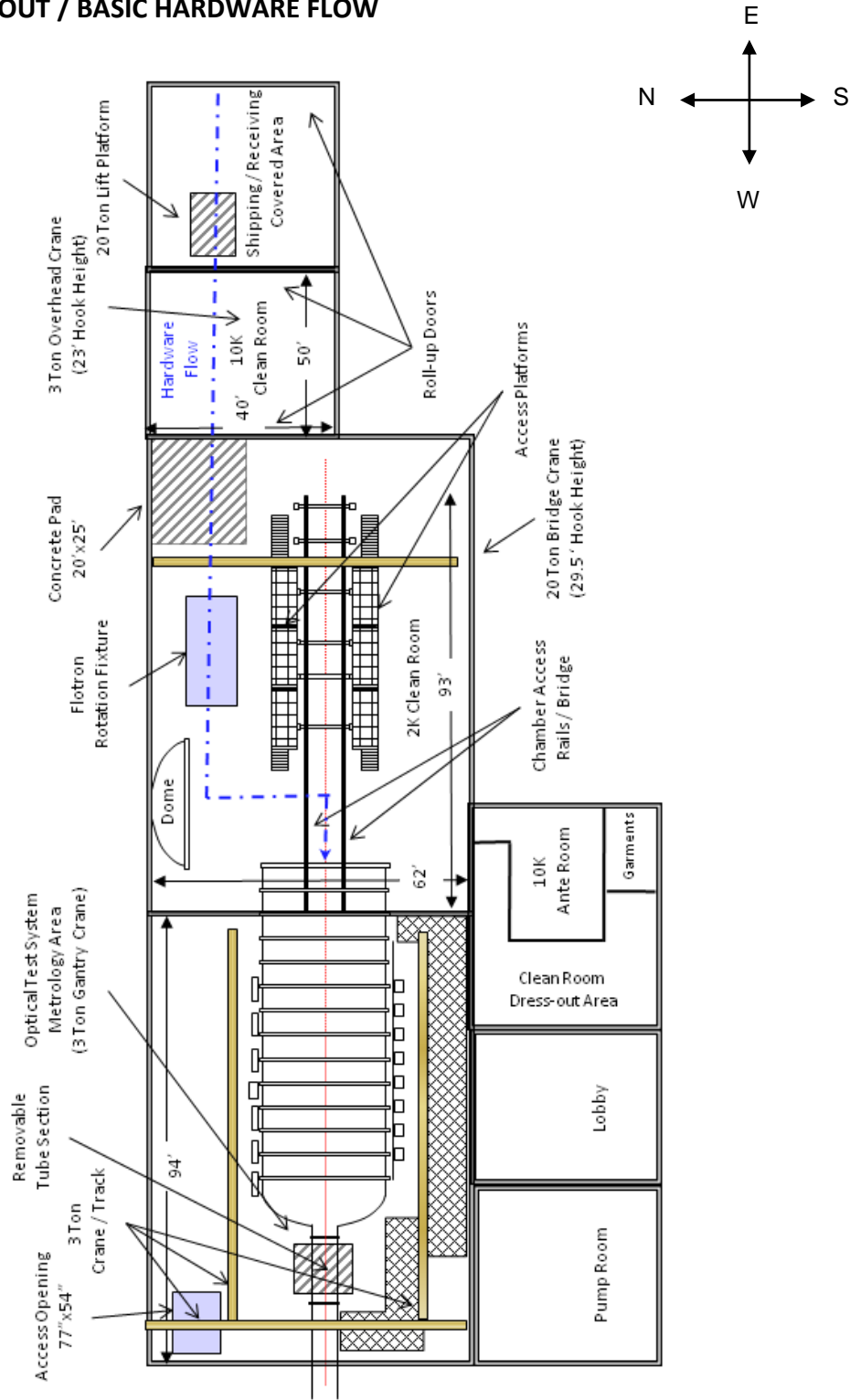



Marshall Space Flight Center X-ray and Cryogenic Facility		
Title- XRCF Handbook	HNBK-FA-XRC-650	Baseline
	Date: March 10, 2016	Page 25 of 32

### X-RAY GUIDE TUBE DETAILS

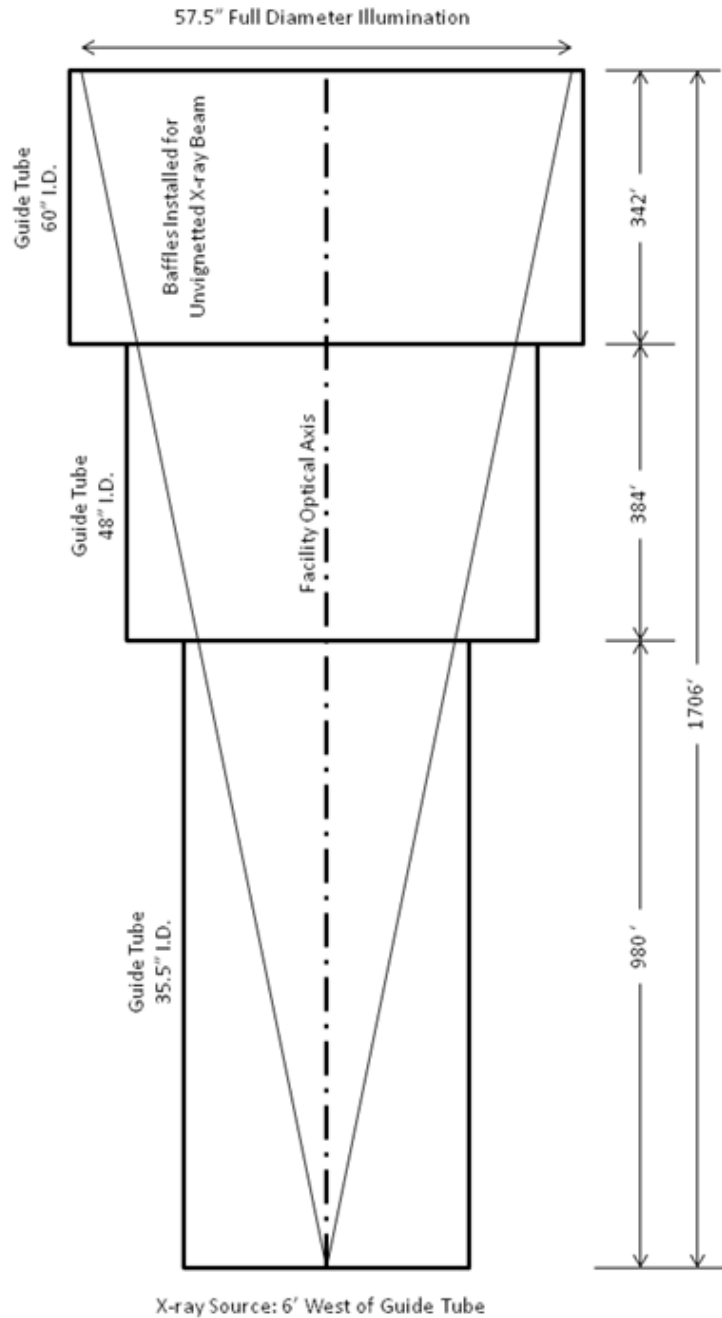

Marshall Space Flight Center X-ray and Cryogenic Facility		
Title- XRCF Handbook	HNBK-FA-XRC-650	Baseline
	Date: March 10, 2016	Page 26 of 32

**AN EXAMPLE CRYOGENIC-OPTICAL TEST CONFIGURATION**

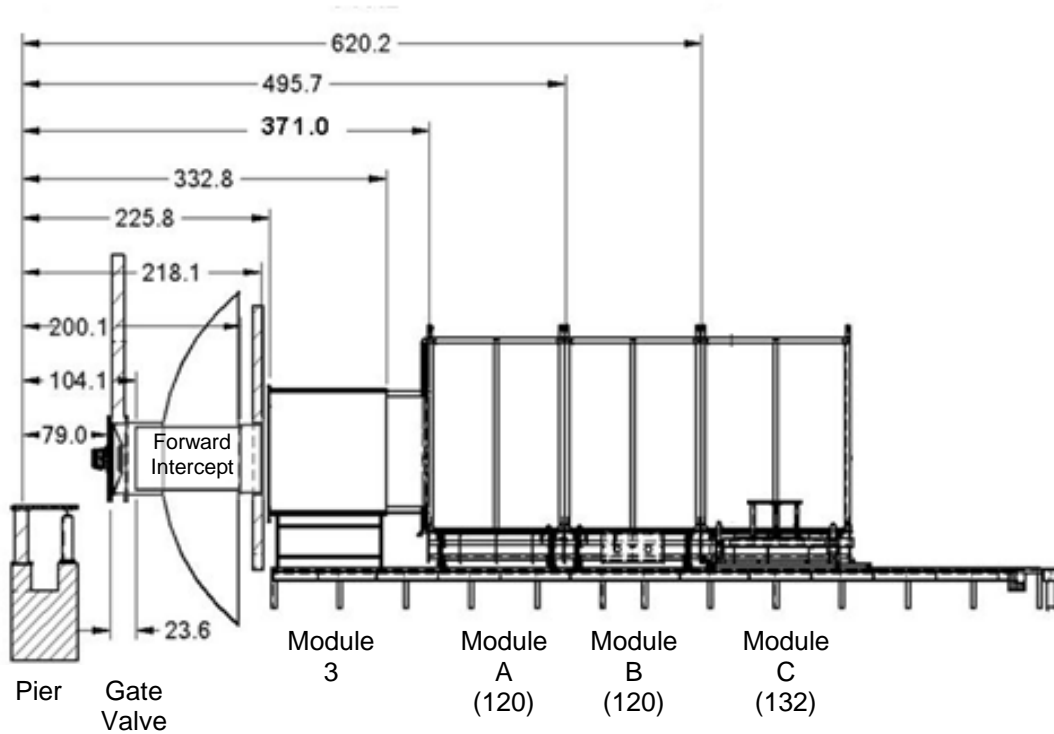

(Dimensions – inches)

To easily locate east-west distances in the facility, a “station number” (STA xx.x) appears on the drawings. This station number is the x-coordinate of the y-z plane corresponding to the location in inches. STA 0 is defined as the centerline of the western pier on the vibration isolation column.

## 6 DEGREE-OF-FREEDOM MOTION STAGE

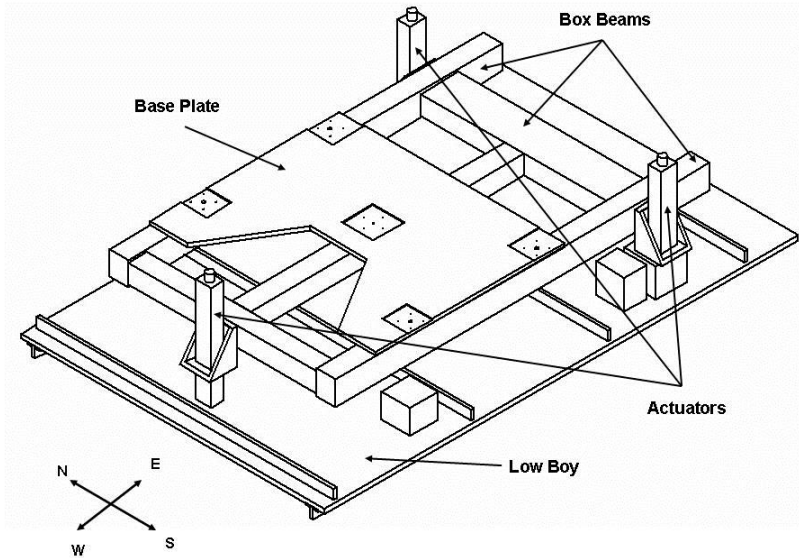

**6 DoF Motion Stage with Base Plate**

Direction	Range	Resolution**
<b>X focus</b>	+/- 1 inch	.0001 inches
<b>Y transverse</b>	+/- .85 inches	.0001 inches
<b>Z vertical</b>	+/- .85 inches	.0001 inches
<b>Θx (roll)</b>	+/- .2 degrees *	1 arc-sec
<b>Θy (pitch)</b>	+/- .3 degrees*	1 arc-sec
<b>Θz (yaw)</b>	+/- .3 degrees*	1 arc-sec

**Motion Stage Performance**

The base plate will serve as the interface between the test article(s) and the six degree-of-freedom positioning stage. Five legs penetrate the cryogenic shroud with a table top for mounting a test article (load capacity <1270 kg)

Marshall Space Flight Center X-ray and Cryogenic Facility		
Title- XRCF Handbook	HNBK-FA-XRC-650	Baseline
	Date: March 10, 2016	Page 28 of 32

**AN EXAMPLE OF CRYOGENIC ENVIRONMENT INSTRUMENTATION & PLUMBING**

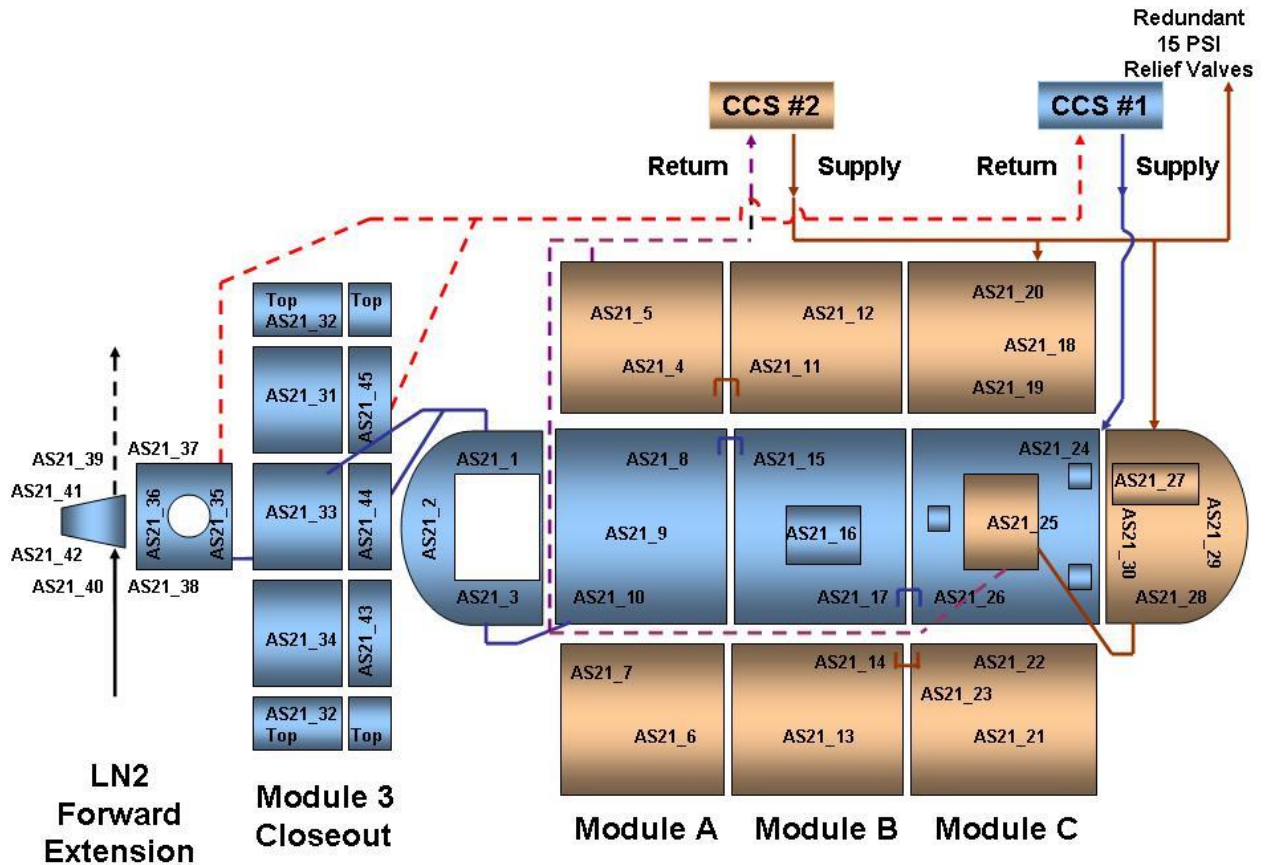

1/08

Lakeshore DT-670C silicon diodes (+/- 1K accuracy from 2K to 305K) will be used for facility temperature monitoring of the helium enclosure environment. An Agilent Model 34970A data acquisition/switch unit will be utilized to acquire facility thermal data via in-house custom software. Figure 3-22 illustrates diode locations on the helium shroud. Facility data is typically recorded on 30 second intervals and provided to the customer at 24 hour intervals.

Marshall Space Flight Center X-ray and Cryogenic Facility		
Title- XRCF Handbook	HNBK-FA-XRC-650	Baseline
	Date: March 10, 2016	Page 29 of 32

## MIRROR TEST CAPABILITY

Currently mirrors that fit inside the green and blue box can be accommodated at XRCF for temperatures from Ambient to < 20 Kelvin. (For temperatures from -200F to +200F the maximum diameter increases to 5.3 meters)

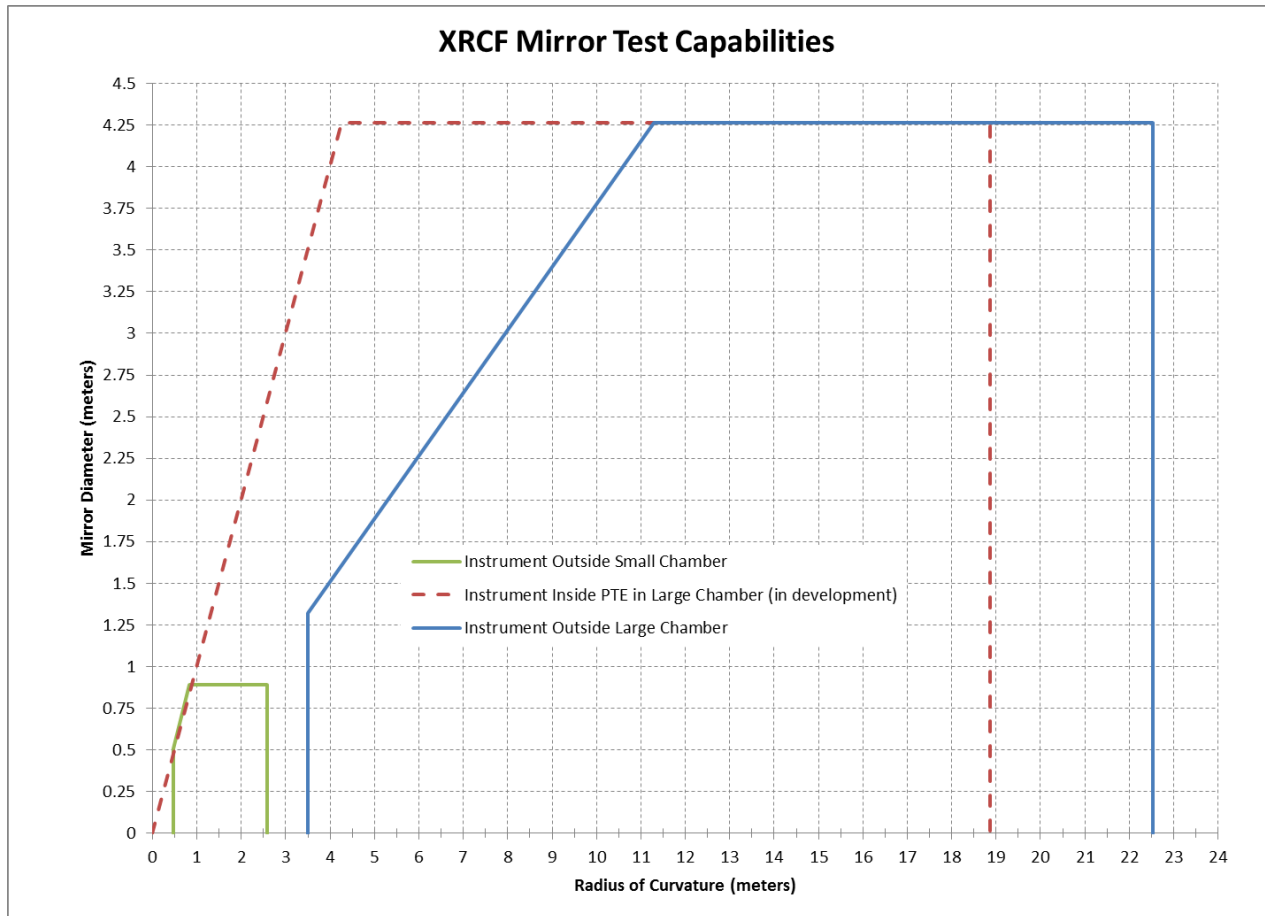

Marshall Space Flight Center X-ray and Cryogenic Facility		
Title- XRCF Handbook	HNBK-FA-XRC-650	Baseline
	Date: March 10, 2016	Page 30 of 32

## CONTAMINATION CONTROL: MATERIAL SELECTION GUIDELINES

### Material Selection Guidelines for Temporary Test Items Used in the X-Ray Calibration Facility (XRCF) Vacuum System at Ambient Temperature and Below

**Objective-** To provide the minimum requirements for materials that will be used to support testing in the XRCF vacuum system at ambient temperature and less. One of the outstanding features of the XRCF is the cleanliness of the vacuum system. These requirements are directed toward preventing unrecoverable contamination to this system. Stricter requirements apply to permanently installed facility items since these items can affect the ability to meet advertised performance criteria. Some programs may require stricter requirements to prevent contamination to the test article.

**Project Material List-** A complete list of materials must be submitted to XRCF at the beginning of the project. The list should include a description of the material, manufacturer, part number, lot number (if applicable), and the quantity used. Include TBD's since they need to be tracked and identified as early as possible. A product description sheet from the manufacturer may be helpful. Include information concerning cure conditions and mix ratios where applicable.

**Metal Items** - Metals with a high vapor pressure such as cadmium, zinc, and mercury shall not be used in the vacuum system. Stainless steels, bare aluminum, aluminum with a non-dyed sulfuric acid conversion coating, OFHC copper, and other suitable corrosion free metals with simple shapes may be used in the chamber following cleaning (see Precision Cleaning section). A structure that has holes, crevices, thread inserts, weldments or other features that could trap contaminants may need to be cleaned and baked (see Thermal Vacuum Bake section). Carbon and alloy steels can be plated with nickel or chromium to render them suitable for temporary use in the vacuum system.

**Glass** - Clean (see Precision Cleaning section).

**Ceramic** - Clean and bake porous ceramics (see Thermal Vacuum Bake). Clean nonporous ceramic (see Precision Cleaning section).

**Non-metallic Items-** Use MSFC-SPEC-1443, ASTM E595, or other approved material list to select materials. It is important to note the test temperature and preconditioning that was performed on the test sample when selecting a material. The use temperature must be less than the tested temperature. Items with large surface areas should be baked (see Thermal Vacuum Bake). Avoid materials such as Polyvinyl Chloride that contain plasticizers. Avoid materials that might produce particulate matter such as cable lacing.

<b>Marshall Space Flight Center X-ray and Cryogenic Facility</b>		
<b>Title-</b> XRCF Handbook	<b>HNBK-FA-XRC-650</b>	<b>Baseline</b>
	<b>Date: March 10, 2016</b>	<b>Page 31 of 32</b>

**Coated Surfaces, Tapes, and Epoxies** - Same as Non-metallic Items above. Some paints and epoxies are suitable to use without a thermal vacuum bakeout if properly air baked and/or time cured.

**Insulated Wire, MLI** - Specify suitable insulation such as Teflon or Kapton insulated wire. Bare or nickel/silver plated wire is fine. Clean and bake (see Thermal Vacuum Bake) at 380° C

**Lubricants** - Only baked and certified Braycote 600 series or Molub-Alloy 2115 lubricants may be used in the vacuum system. Silicone lubricants shall not be used in the vacuum system.

**Motors, Assemblies** - Motors and other assemblies should be selected so that the above requirements are met. Particular attention should be applied to the complete removal of improper lubricants, re-lubrication using acceptable lubrication (see Lubricant section), and the use of proper wire insulation. Motors should have thermal protection to prevent overheating. If the limitations of the material testing specification prevents adequate testing of all components of an assembly, then the item should be cleaned and baked (see Thermal Vacuum Bake). The bake temperature of an assembly must exceed the maximum expected temperature of the item.

**Thermal Vacuum Bake** - Generally, the hotter and longer the item can be baked, the better the chance that the item will not contaminate the chamber and or test article. Items are typically baked at 50°C, < 5X 10<sup>-6</sup> torr for at least 48 hours unless otherwise noted. Visible degradation of the material during bakeout will obviously result in the rejection of the material. Some materials must be qualified for use by monitoring the outgassing levels during the bake.

**Precision Cleaning** - Mil-Std-1246, Level 500A or equal.

**Others and exceptions** - Items not covered by these guidelines or exceptions must be noted and agreed to before start of test. XRCF reserves the right to reject the use of any material at any time due to concern of potential contamination to the XRCF vacuum system.

Marshall Space Flight Center X-ray and Cryogenic Facility		
Title- XRCF Handbook	HNBK-FA-XRC-650	Baseline
	Date: March 10, 2016	Page 32 of 32

## X-RAY SOURCES & DETECTORS

### X-Ray Sources & Detectors

#### Sources (0.1 to 10 keV):

- Electron Impact Point Source
- Penning Inert Gas Discharge Source
- Rotating Anode Sources
- High Resolution Erect Field Spectrometer
- Double Crystal Monochrometer

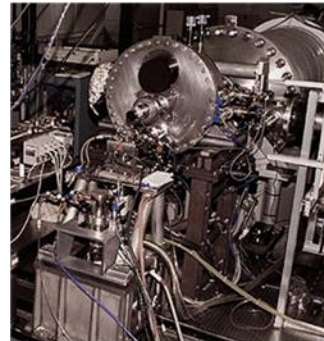

X-ray Point Source

#### Detectors:

- Flow Proportional Counters
- Solid State Detectors
- High Speed Imager
- CCD



Focal Plane X-ray Detector System

X-ray illumination systems located 525m from chamber capable of 0.1 to 10keV. Beam diameter = 1.46m. Beam monitoring and focal plane x-ray detectors and imaging systems.