

A Miniaturized Variable Pressure Scanning Electron Microscope (MVP-SEM) for the Surface of Mars: An Instrument for the Planetary Science Community

J. Edmunson¹, J. A. Gaskin², G. Danilatos³, I. J. Doloboff⁴, M. R. Effinger², R. P. Harvey⁵, G. A. Jerman², R. Klein-Schoder⁶, W. Mackie⁷, B. Magera⁷, and E. L. Neidholdt⁴

¹Jacobs ESSA Group/NASA Marshall Space Flight Center, ²NASA Marshall Space Flight Center, ³Environmental SEM Research Laboratory, ⁴Jet Propulsion Laboratory, California Institute of Technology, ⁵Case Western Reserve University, ⁶Creare LLC, ⁷Applied Physics Technologies, Inc.

INTRODUCTION

The Miniaturized Variable Pressure Scanning Electron Microscope (MVP-SEM) project, funded by the NASA Planetary Instrument Concepts for the Advancement of Solar System Observations (PICASSO) Research Opportunities in Space and Earth Science (ROSES), will build upon previous miniaturized SEM designs for lunar and International Space Station (ISS) applications [1, 2] and recent advancements in variable pressure SEM's [e.g., 3] to design and build a SEM to complete analyses of samples on the surface of Mars using the atmosphere as an imaging medium. By the end of the PICASSO work, a prototype of the primary proof-of-concept components (i.e., the electron gun, focusing optics and scanning system) will be assembled and preliminary testing in a Mars analog chamber at the Jet Propulsion Laboratory will be completed to partially fulfill Technology Readiness Level to 5 requirements for those components. The team plans to have Secondary Electron Imaging (SEI), Backscattered Electron (BSE) detection, and Energy Dispersive Spectroscopy (EDS) capabilities through the MVP-SEM.

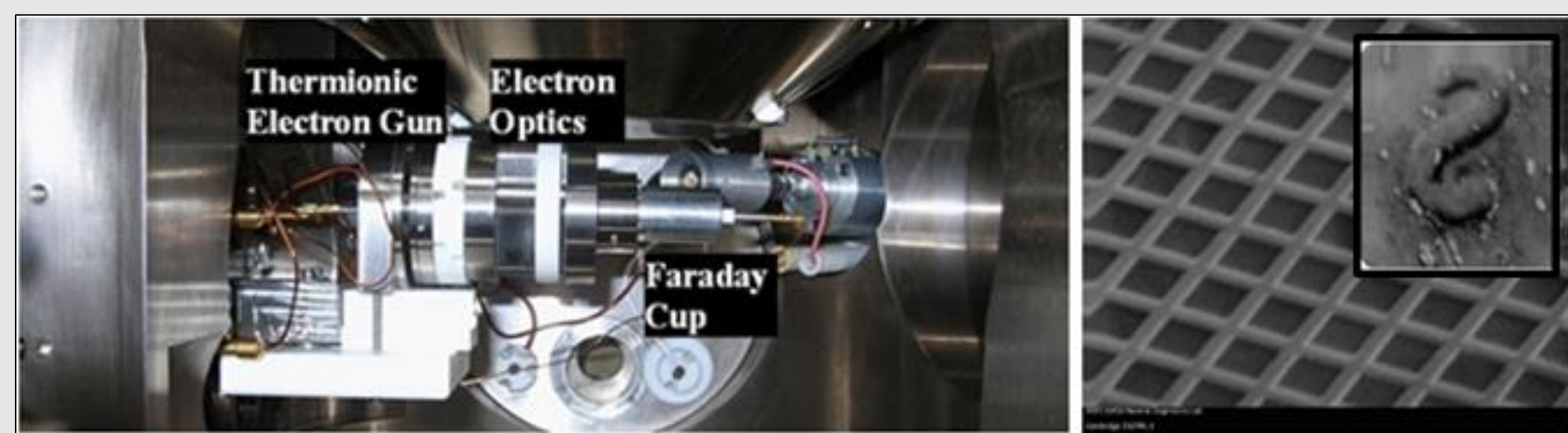

Figure 1: (Left) Lunar Miniaturized Scanning Electron Microscope attached to a commercial-off-the-shelf (COTS) electron gun. A Faraday cup was attached to measure beam current, which was later replaced with a scanning coil assembly for imaging. (Right) The instrument's images of a copper grid standard and the letter "S" on a penny. (Credit: NASA/J. Gaskin)

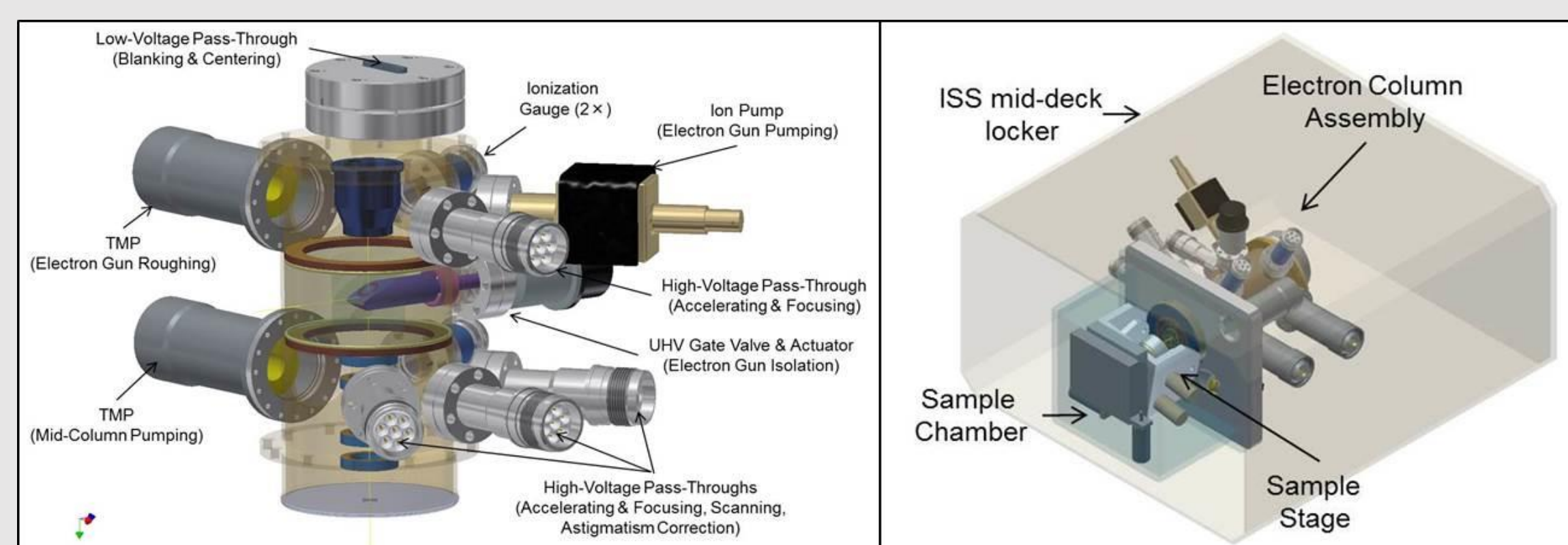

Figure 2: (Left) ISS miniaturized SEM electron column layout. This layout includes the electron column, pumps, vacuum gauges, and high voltage pass-throughs. The main assembly is slightly larger than a 12oz soda can. (Right) Diagram on the electron column assembly inside of a mid-deck locker on the ISS as shown. A sample chamber has been designed to allow for manual sample insertion. (Credit: Creare/R. Klein-Schoder and reproduced with permission)

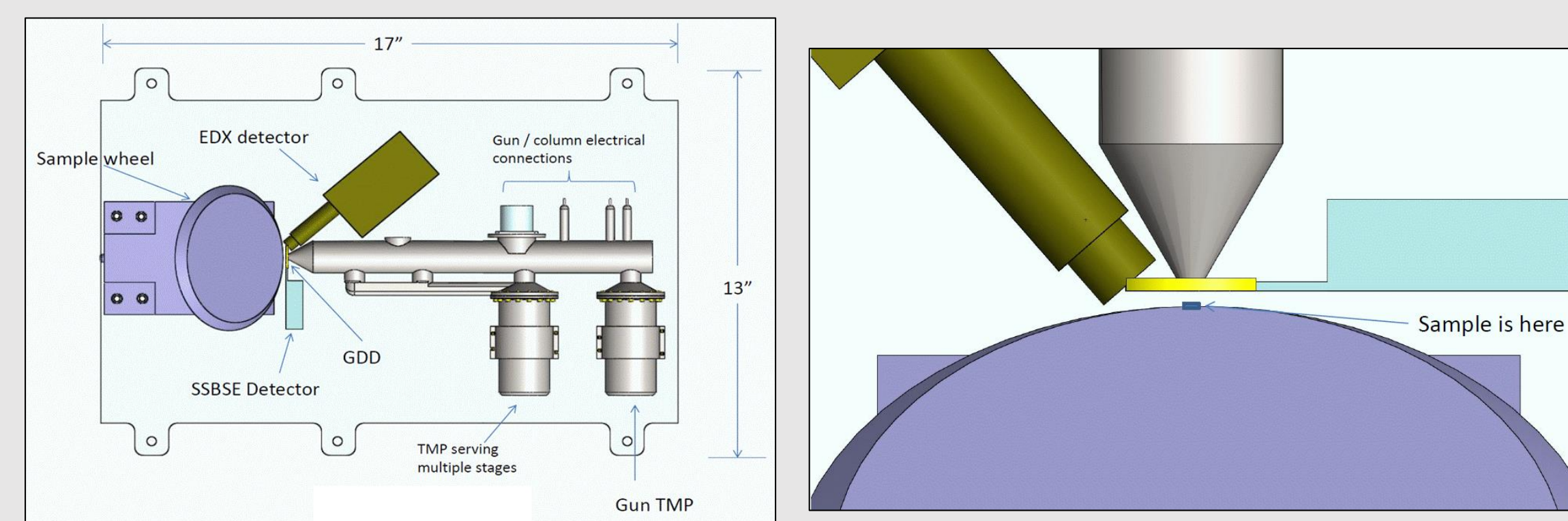

Figure 3: (Left) Preliminary feasibility concept for the MVP-SEM. The current concept has roughly a 17" x 13" footprint. (Right) Zoomed-in drawing of the sample region. The detectors shown are a combination of COTS and custom and are meant to allow for conceptual visualization. This design will change as the instrument requirements solidify and the development progresses. (Credit: JPL-Caltech/E. Neidholdt)

SCIENCE GOALS & REQUIREMENTS

It is the desire of the MVP-SEM team to engage the planetary science community in setting the science goals and requirements of the instrument. The original defined science requirements were presented in [4], were fairly general, and focused primarily on petrology. Refined requirements are expected to yield greater constraints on the instrument and its capabilities. For example, data needs for the calculation of stoichiometry and the identification of reduced or oxidized forms of minerals will require greater precision for EDS for specific elements. The team is looking for inputs from the planetary science community to define a data set that will be useful to the majority of the community. Therefore, all contributions are welcome. A refined set of requirements for the instrument will be produced from the gathered information.

A Science Traceability Matrix (table below) shows the flow-down of the NASA Strategic Goals to the functional requirements of the instrument. Many of the Mars Exploration Program Analysis Group (MEPAG) investigations require both geomorphology and geochemistry of the samples. Remaining testing to define the capabilities of the instrument include EDS sensitivity in the CO₂-rich atmosphere and the amount of beam current needed at the sample for precise results.

MVP-SEM Science Traceability Matrix									
NASA 2014 Strategic Plan Goal 1	MEPAG Goals	MEPAG Objectives	Scientific Measurement Requirements		Instrument Functional Requirements	Projected Performance	Mission Functional Requirements (Top Level)		
			Physical Parameters	Observables					
Expand the frontiers of knowledge, capability, and opportunity in space (Ascertain the content, origin, and evolution of the solar system and the potential for life elsewhere – Strategic Objective 1.5)	1. Determine if Mars ever supported life	1A. Determine if environments having high potential for prior habitability and preservation of biosignatures contain evidence for past life	Combined geological analyses such as: Mineral and phase geochemistry Mineral and phase morphology Biological morphology Grain size and shape Location of concentrations of elements (x-ray mapping)	Geochemistry	Characteristic X-rays	Detection precision (major elements) using Energy Dispersive Spectroscopy	2 weight percent or better	TBD – EDS testing underway	<ul style="list-style-type: none"> Operation in the martian surface environment Little to no sample preparation Capability to analyze multiple samples
		1B. Determine if environments with high potential for current habitability and expression of biosignatures contain evidence of extant life			Backscattered Electrons	Sufficient contrast to note mineral and phase chemical zoning	Required emitter current?	?	
	3. Understand the origin and evolution of Mars as a geological system	3A. Document the geologic record preserved in the crust and interpret the processes that have created that record	Geochemistry	Imaging, Topography	Resolve uncoated objects	Environmental SEM mode	Sample Chamber Pressure Control to <1 Torr Electron Gun Chamber Pressure Control to <1x10 ⁻⁶ Torr	1mm	<ul style="list-style-type: none"> Low vibration for increased imaging resolution Automated survey software and feature identification subroutines
		3B. Determine the structure, composition, and dynamics of the martian interior and how it has evolved			FOV	1mm or greater	100nm in size or better	20nm	
4. Prepare for human exploration	4B. Obtain knowledge of Mars sufficient to design and implement a human mission to the martian surface with acceptable cost, risk, and performance					Magnification	20X to 5000X or better	25,000X	<ul style="list-style-type: none"> Data made available to the public through the Planetary Data System

TESTING & MODELING

This phase in the development of the MVP-SEM involves testing and modeling for the proof-of-concept design. The current focus of the team has been on the following testing and modeling efforts:

- Determining the applicable operating conditions and parameters for imaging using a SEM with the martian atmosphere as the sample chamber gas. For this study, a FEI Quanta 600 Field Emission Gun SEM at NASA's Marshall Space Flight Center is used. This involved systematically changing operating parameters such as beam accelerating voltages, beam current, environmental distance, sample chamber pressure, and magnification. Results are summarized in [4].
- Determining the appropriate electron gun for the environment with sufficient lifetime for mission success. Some types of electron guns are better suited for operation on Mars than others. Emitter lifetime can be cut short by evaporation caused by oxidation. Testing was completed, in which a CO₂ atmosphere was slowly leaked into the electron gun chamber, mimicking the variable pressure aspect of an environmental SEM. No difference was found in the lifetime of the electron gun in a CO₂-rich atmosphere compared to an N₂-rich (common terrestrial) atmosphere.
- Modeling the electron optics. The electron optics need to be able to achieve better than 100 nm resolution (20 nm is predicted) and accommodate the required magnifications and field-of-view (FOV) necessary to satisfy the science requirements. This mini-column will need to be fairly compact and will mate to the electron gun and sample chambers.
- Modeling the overall instrument geometry, as it will be affected by the size of the electron gun, the focusing optics, vacuum system, and sample system. The sample region will need to accommodate three detectors (for SEI, BSE, and EDS) and integrate to a sample wheel (or other delivery mechanism). Ideal characteristics for this delivery mechanism include allowing for samples to be translated under the electron beam, unlimited sample number, and accommodating sample caching and pass-offs to other instruments. A current concept of the MVP-SEM detector geometry is presented in Figure 3.

FUTURE WORK

At the end of this PICASSO effort, the team will continue development of the instrument through the Maturation of Instruments for Solar System Exploration (MatISSE) ROSES opportunity.

The team would like to thank the PICASSO program and reviewers for supporting our project!

REFERENCES

- [1] Gaskin J. A. et al. (2012) *IEEE Aerospace*, doi: 10.1109/AERO. 2012.6187064. [2] Thaisen et al. (2009) LPSC XL, Abstract #1697. [3] Fitzek H. et al. (2015) *J. Microscopy*, doi: 10.1111/jmi.12347. [4] Edmunson et al. (2016) 47th LPSC, Abstract #2301.

What would YOU study if you had a SEM on Mars?

Let us know!

www.surveymonkey.com/r/VBNZNDZ

- No personally identifiable information (PII) required.
- Any PII voluntarily provided will be deleted from contributions.
- The contributed information will not be published.
- The goal is to identify useful information for the planetary community that can be obtained via specific SEM studies or instrument requirements.