

# The NASA Electronic Parts and Packaging (NEPP) Program: NEPP Overview - Automotive Electronics

**Kenneth A. LaBel**  
[ken.label@nasa.gov](mailto:ken.label@nasa.gov)  
301-286-9936

**Michael J. Sampson**  
[michael.j.sampson@nasa.gov](mailto:michael.j.sampson@nasa.gov)  
301-614-6233

**Co- Managers, NEPP Program**  
**NASA/GSFC**  
<http://nepp.nasa.gov>

Acknowledgment:  
This work was sponsored by:  
NASA Office of Safety & Mission Assurance

*Open Access*



*Sundown Villa Grazioli, Frascati, Italy, Mike Sampson*

# Acronyms

Acronym	Definition
AEC	Automotive Electronics Council
AECQ	Automotive Electronics Council Qualified
Aero	Aerospace
AFRL	Air Force Research Laboratory
BME	Base Metal Electrode
BOK	Body of Knowledge
CBRAM	Conductive Bridging Random Access Memory
CCMC	Community Coordinated Modeling Center
CDH	Central DuPage Hospital Proton Facility, Chicago Illinois
CMOS	Complementary Metal Oxide Semiconductor
CNT	Carbon Nanotube
COP	Community of Practice
COTS	Commercial Off The Shelf
CRÈME	Cosmic Ray Effects on Micro Electronics
DC	Direct Current
DLA/DSCC	Defense Logistics Agency Land and Maritime
EEE	Electrical, Electronic, and Electromechanical
ELDRS	Enhanced Low Dose Rate Sensitivity
EP	Enhanced Plastic
EPARTS	NASA Electronic Parts Database
ESA	European Space Agency
FPGA	Field Programmable Gate Array
FY	Fiscal Year
GaN	Gallium Nitride
GSFC	Goddard Space Flight Center
HUPTI	Hampton University Proton Therapy Institute
IBM	International Business Machines
IPC	International Post Corporation
IUCF	Indiana University Cyclotron Facility
JEDEC	Joint Electron Device Engineering Council
JPL	Jet Propulsion Laboratories
LaRC	Langley Research Center
LEO	Low Earth Orbit
LLUMC	James M. Slater Proton Treatment and Research Center at Loma Linda University Medical Center
MGH	Massachusetts General Hospital

Acronym	Definition
MIL	Military
MLCC	Multi-Layer Ceramic Capacitor
MOSFETS	Metal Oxide Semiconductor Field Effect Transistors
MRAM	Magneto resistive Random Access Memory
MRB	Material Review Board
MRQW	Microelectronics Reliability and Qualification Working Meeting
MSFC	Marshall Space Flight Center
NASA	National Aeronautics and Space Administration
NAVY Crane	Naval Surface Warfare Center, Crane, Indiana
NEPAG	NASA Electronic Parts Assurance Group
NEPP	NASA Electronic Parts and Packaging
NPSL	NASA Parts Selection List
PBGA	Plastic Ball Grid Array
POC	Point of Contact
POL	Point of Load
ProCure	ProCure Center, Warrenville, Illinois
QML	Qualified Manufacturers List
QPL	Qualified Product List
RERAM	Resistive Random Access Memory
RF	Radio Frequency
RHA	Radiation Hardness Assurance
SAS	Supplier Assessment System
SEE	Single Event Effect
SEU	Single Event Upset
SiC	Silicon Carbide
SME	Subject Matter Expert
SOC	Systems on a Chip
SOTA	State of the Art
SPOON	Space Parts on Orbit Now
SSDs	Solid State Disks
TI	Texas Instruments
TMR	Triple Modular Redundancy
TRIUMF	Tri-University Meson Facility
VCS	Voluntary Consensus Standard
VNAND	Vertical NAND

# Overview - Automotive Electronic Parts

- In US, supplied in accordance with Automotive Electronics Council (AEC) specifications
- AEC URL: <http://www.aecouncil.com/> Documents are FREE
- NEPP evaluation objectives:
  - Procure sample parts and evaluate as received performance and parametric compliance
  - Perform burn-in and life test to evaluate reliability
- Naval Surface Warfare Center (NSWC) Crane Indiana, providing test capabilities
- Parts selected:
  - chip capacitors, ceramic and dry slug tantalum
  - discrete semiconductors
  - microcircuits
- Initial results on capacitors showed unexpected behavior
- Finding subtle, non obvious differences, COTS to Aerospace Hi Rel and COTS to COTS
- Typically auto is just one grade of COTS offered

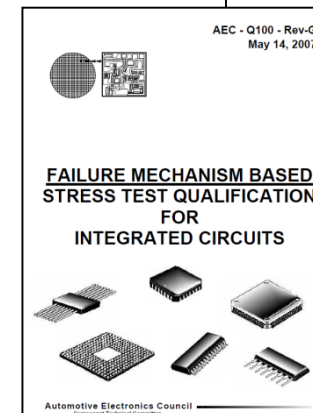

# **You May Think the “Big Three” Would Directly Oversee US Standards for Automotive Grade EEE Parts, But...**

**Chrysler**

**Ford**

**GM**

# Automotive Electronics Council (AEC) Controls the AEC “Q” Specifications for Automotive EEE Parts

## Sustaining Members



## Technical, Associate and Guest Members

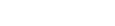
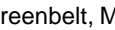
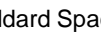
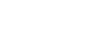

# So Why Automotive Parts for Space?



- Parts from manufacturers that are qualified to the AEC Q specifications have advantages
  - Designs meet basis AEC qualification requirements (quite rigorous)
  - Produced in high volumes using sophisticated processes
  - Reliability problems more likely to become public knowledge than similar problems for general purpose commercial (large, homogenous market)
- They are cost competitive to catalog COTS

# Cost Comparison Data and Discussion

- Automotive parts are inexpensive but large minimum order quantity purchases can be required - into the thousands.
- Cost comparisons with MIL, medical and commercial parts found AECQ parts similar to catalog commercial and between 5% and 15% of the cost of MIL and medical
- No radiation data available for AECQ parts
- Additional screening costs (including radiation assurance) may be required to meet mission requirements before automotive parts can be used in low risk space applications
- Need to consider full cost of ownership if COST is the driver



# Automotive Electronic Parts

In US, Automotive Grade EEE Parts are **qualified** in accordance with Automotive Electronics Council (AEC) specifications “AEC Q”

## AEC Q-100 Microcircuits

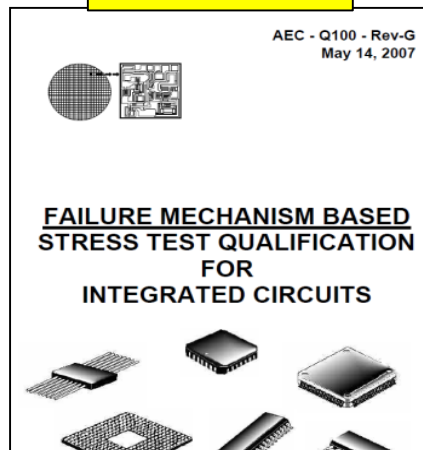

## AEC Q-101 Discrete Semiconductors



## AEC Q-200 Passives



Grade	Temperature Range	AEC 100 Microcircuits	AEC 101 Discrete Semiconductors		AEC 200 Passives
			Except LEDs	LEDS	
0	-40°C to +150°C	X	—	—	X
1	-40°C to +125°C	X	X	—	X
2	-40°C to +105°C	X	—	—	X
3	-40°C to +85°C	X	—	X	X
4	0°C to +70°C	X	—	—	X

# AEC Specification System

## A Brief Overview

- AECQ Documents describe **Qualification** requirements
- **Screening** is an acknowledged option but AECQ documents impose no requirements or guidance
- **Common Misunderstandings:**
  - A document called a Production Part Approval Process (PPAP) is required by the AEC specifications
  - The PPAP is required by ISO/TS 16949\*
  - The PPAP must include AEC qualification data
  - There is a rigid format and content for a PPAP

- The PPAP is a process used in the automotive supply chain to improve communication between supplier and customer
- Keyword searches found no substantive cross-referencing of the PPAP or 16949 in the AECQ specifications or between 16949 and the PPAP

**There are no formal relationships between, AEC, PPAP and 16949 although PPAP content is “aligned” with ISO 9001:2008**

**\*ISO TS 16949 Quality management systems — Particular requirements for the application of ISO 9001:2008 for automotive production and relevant service part organizations**

# ISO TS 16949

TECHNICAL  
SPECIFICATION

ISO/TS  
16949

Third edition  
2009-06-15

- A Quality Management System specifically for automotive production
- Certification by a third party
- Augmented by periodic audits by the automobile manufacturers and their sub-system suppliers

---

---

**Quality management systems —**

**Particular requirements for the application  
of ISO 9001:2008 for automotive production  
and relevant service part organizations**

*Systèmes de management de la qualité —*

*Exigences particulières pour l'application de l'ISO 9001:2008 pour la  
production de série et de pièces de rechange dans l'industrie automobile*

# So what is a Production Part Approval Process (PPAP)?

- A PPAP is a data package in accordance with the PPAP manual published by the Automotive Industry Action Group ([AIAG](#))
- The current revision is the 4<sup>th</sup> edition, dated June 2006
- The PPAP consists of 18 elements
  - No standard format; depth of content varies widely between manufacturers
  - Manufacturer decides elements to make readily available versus “on-site” only
- Examples of the elements:
  1. Design records
  2. Engineering Change Documents
  3. Design Failure Modes and Effect Analysis (DFMEA)
  4. Process Flow Diagram
  5. Process Failure Modes Effect Analysis (PFMEA)
  6. Control Plan
  7. Records of Material/Performance Tests
  8. Initial Process Studies
  9. Qualified Laboratory Documentation
  10. Sample Production Parts
  11. Customer-specific requirements
  12. Parts Submission Warrant (PSW)

PPAP Levels	PPAP Submission Requirements
1	Product Submission Warrant only (and for designated appearance items, an Appearance Approval Report) submitted to customer
2	Product Submission Warrant with product samples and limited supporting data submitted to customer
3	Product Submission Warrant with product samples and complete supporting data submitted to customer.
4	Product Submission Warrant and other requirements as defined by customer.
5	Product Submission Warrant with product samples and complete supporting data reviewed at organization's manufacturing location.

# NEPP Evaluation of Automotive EEE Parts

## The Plan

- Procure sample Automotive Grade EEE parts
  - Procure via authorized distribution or direct from manufacturer
  - Parts advertised by supplier to meet “AECQ” requirements
  - Ceramic chip capacitors (base metal electrode from 3 different suppliers)
  - Discrete semiconductors (2 diodes, 1 transistor, 1 transient voltage suppressor)
  - Microcircuits (1 digital, 1 linear)
  - Later added some tantalum chip capacitors, a precious metal electrode ceramic chip sample and also obtaining one more base metal ceramic chip
- Evaluate **as received performance and parametric compliance**
  - Perform burn-in and life test to evaluate reliability
  - Naval Surface Warfare Center (NSWC) Crane Indiana provides testing

# Testing Summary: NEPP Evaluation Automotive Parts Ceramic Capacitors

*Parts were purchased through distributors as Automotive Electronics Council (AEC) Q-200 Automotive Grade*

Commodity	Test	Status	Comments
<b>0805 Size</b> 0.47uF, 50V  3 Different Mfrs  All Use BME Technology	Construction Analysis	Complete	<ul style="list-style-type: none"> <li>All 3 Lots use BME Technology</li> <li><b>At their own discretion a manufacturer supplied devices made with "flexible termination"</b></li> </ul>
	Initial Parametric Measurements	Complete	<ul style="list-style-type: none"> <li>No Failures</li> <li>DWV known to produce negative cap shift                             <ul style="list-style-type: none"> <li>Mfrs recommend bake-out to restore cap</li> </ul> </li> </ul>
	Life Test* (2x Vrated, 125°C)	> 8000 Hrs Complete (Progressing to 10k hours)	<ul style="list-style-type: none"> <li>1 lot exhibits <b>8 catastrophic short life test failures (120pc)</b></li> <li>2 fail @ 3.1k hrs; 3 fail @ 4.7khrs; 1 fail @ 6.2khrs; 2 fail @7khrs</li> <li>2 other lots starting to exhibit IR degradation after 7.5khrs</li> </ul>
<b>0402 Size</b> 0.01uF, 16V  3 Different Mfrs  2 BME & <u>1 PME</u>	Construction Analysis	In Process	<ul style="list-style-type: none"> <li>2 Suppliers advertise BME and 1 advertises PME</li> </ul>
	Initial Parametric Measurements	Complete	<ul style="list-style-type: none"> <li>No Failures</li> </ul>
	Life Test* (2x Vrated, 125°C)	> 2000 Hrs Complete (Progressing to 10k hours)	<ul style="list-style-type: none"> <li>No Catastrophic Failures</li> <li>PME lot has most stable IR through 2k hrs</li> <li>Both BME lots showing initial signs of Hot IR degradation at ~500 Hrs</li> </ul>

\* MIL requires 2000hrs, 0 failures for qualification

BME = Base Metal Electrode  
 DWV=Dielectric Withstanding Voltage  
 IR = Insulation Resistance  
 PME = Precious Metal Electrode

# Testing Summary: NEPP Evaluation Automotive Parts ICs and Discrete Semiconductors

Parts were purchased through distributors as Automotive Electronics Council (AEC) Q-100 and Q101

Commodity	Test	Status	Comments
<b>Integrated Circuits</b> 2 Different Mfrs  1 Diff Bus Transceiver 1 Comparator	Construction Analysis	In Process	<ul style="list-style-type: none"> <li>• <b>Mold Flash and/or FOD on Terminals "As-Received" (Linear IC)</b></li> <li>• Tg measurements complete</li> <li>• CSAM complete for digital IC</li> <li>• CA to be performed at end of life test</li> </ul>
	Initial Parametric Measurements	Complete	<ul style="list-style-type: none"> <li>• <b>No Failures</b></li> </ul>
	Burn-In & Life Test*	In Process	<ul style="list-style-type: none"> <li>• <b>Differential Bus Transceiver Life Test RESTART Pending. Initial Life Test Aborted due to Insufficient Decoupling Capacitance.</b></li> <li>• <b>Comparator Burn-In Complete. Life Test Pending</b></li> </ul>
<b>Discrete Semiconductors</b>  1 Bipolar transistor (dual) 1 Switching diode 1 Transient Voltage Suppressor 2 Schottky Diodes	Construction Analysis	In Process	<ul style="list-style-type: none"> <li>• Tg measurements complete</li> <li>• CA to be performed at end of life test</li> </ul>
	Initial Parametric Measurements	In Process	<ul style="list-style-type: none"> <li>• No Failures for bipolar transistor</li> <li>• Switching diode to be tested 07/15</li> </ul>
	Burn-In & Life Test*	In Process	<ul style="list-style-type: none"> <li>• <b>Bipolar transistor – 3500 hours of life test completed (20 pcs) – No Failures To Date, 5500 hours read point pending</b></li> <li>• Switching diode test start delayed due to parts ordering issue</li> </ul>

Manufacturer	Lot Code	Description	Quantity on Test	Life Testing Status	Comments
A	1302	Ceramic Chip Capacitor, 0805, 0.47uF, 50V	120	10khrs	120 pcs on test. 17 catastophic life test failures with first occurring ~3.1khrs
B	1304		120	10khrs	120 pcs on test. IR degradation noticed @7.5khrs; 3 catastophic failures beyond 8khrs of test
C	1131		120	10khrs	120 pcs on test. No Catastrophic Life Test Failures
D	201028	Ceramic Chip Capacitor, 0402, 0.01uF, 16V	78	>2k Hrs	few devices exhibit reduced IR (non-catastrophic)
E	TBD		80	>2k Hrs	few devices exhibit reduced IR (non-catastrophic)
F	1247		79	>2k Hrs	Stable IR thus far. Note: Precious Metal Electrode
G	TBD	Microcircuit, Transceiver	50	Not yet started	Initial Electricals in Progress
H	1152	Microcircuit, Comparator	50	Not yet started	Initial Electricals in Progress
I	1341	Microcircuit, Op Amp	50	Not yet started	Test Program in Development
J	unknown	Dual small signal NPN Bipolar transistor (similar to 2N2919 and 2N2920 MIL-PRF-19500/355)	20	>4.5k Hrs	1 failure at 1k Hrs. Failure may be handling related. Life test has completed 4.5khrs with no additional failures. Life test continuing to 5.5khrs or until a failure occurs
K	1339	Switching diode (similar to 1N4148, MIL-PRF-19500/116)	20	Not yet started	Radiography completed. Initial electrical testing completed. High Temp Reverse Bias burn-in will be starting soon
L	unknown	Transient Voltage Suppressor, 36V minimum breakdown voltage, 400 watt peak pulse power	20	Not yet started	Parts Procured. Test Plan is being reviewed at Crane. Electrical test and life test boards to be fabricated

# AECQ Ceramic Chip Capacitors, Insulation Resistance at 125°C

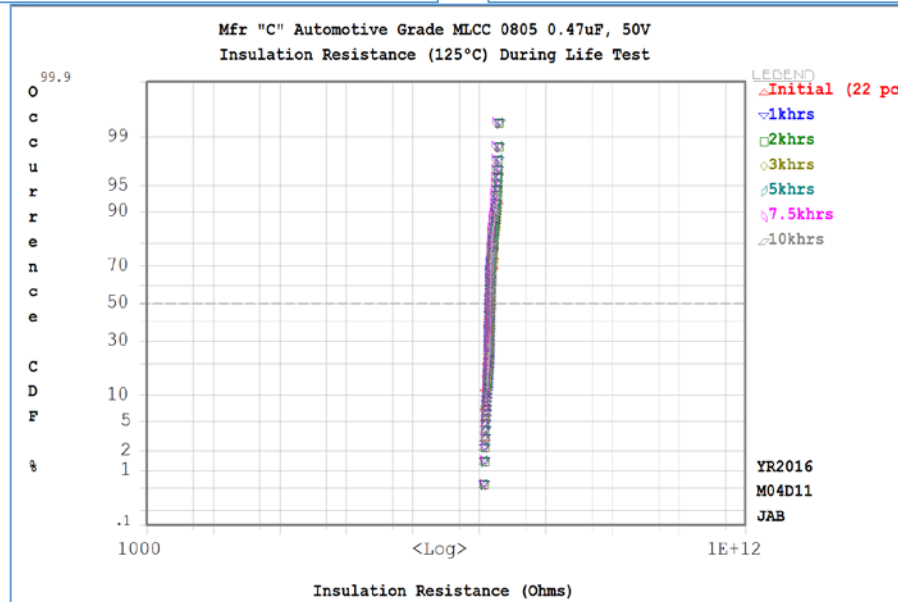
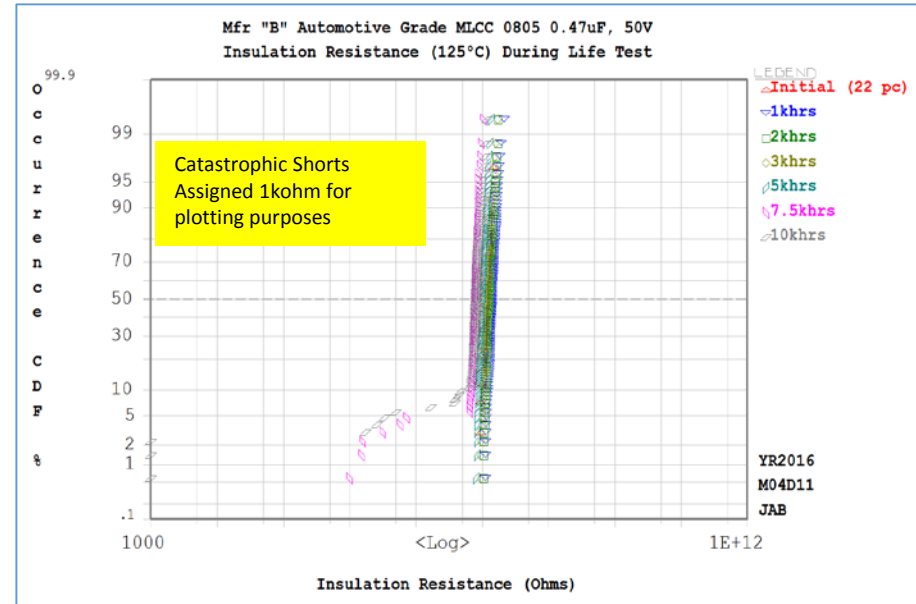
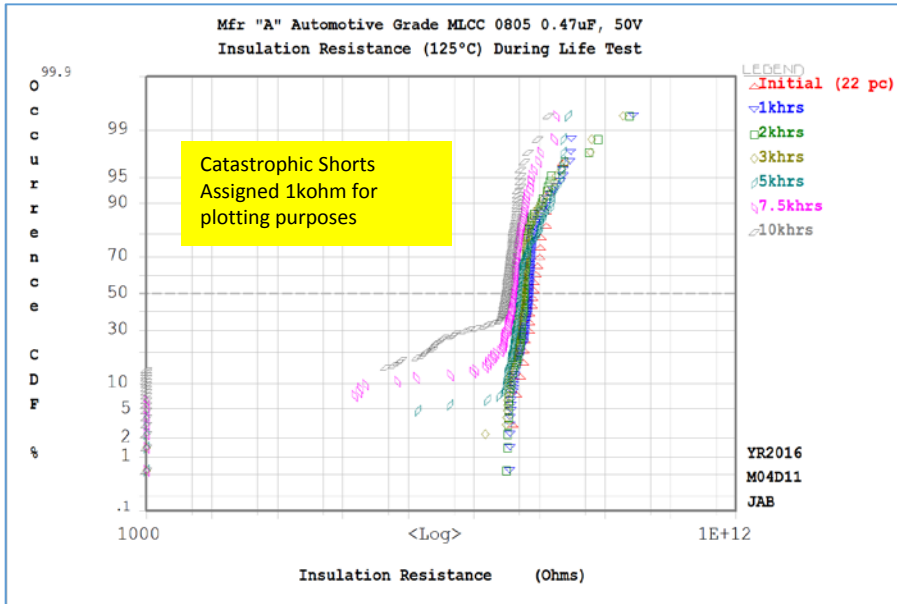

# Example of Catastrophic Life Test Failure

## Mfr "A" Ceramic Chip Capacitor - Short Circuit

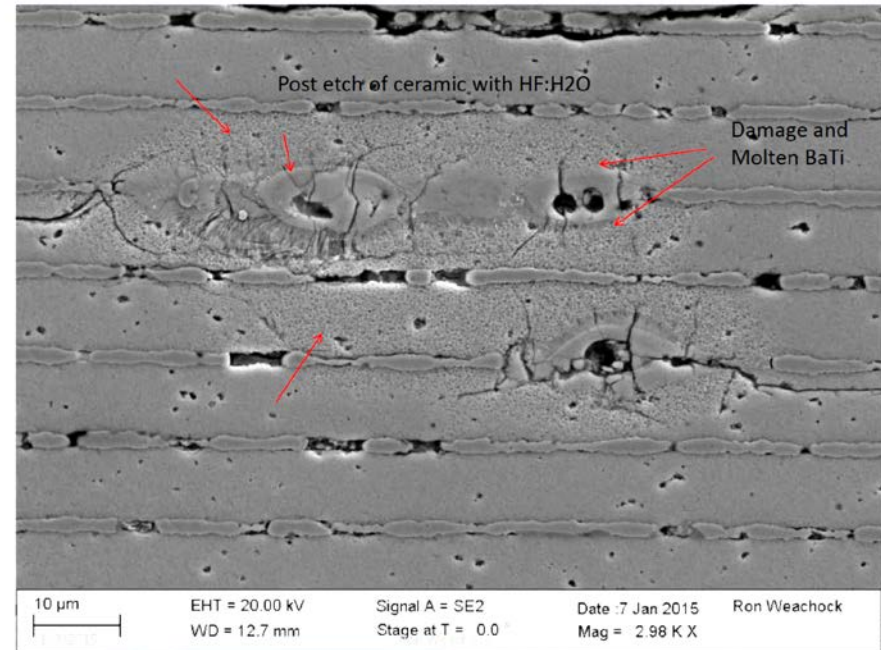
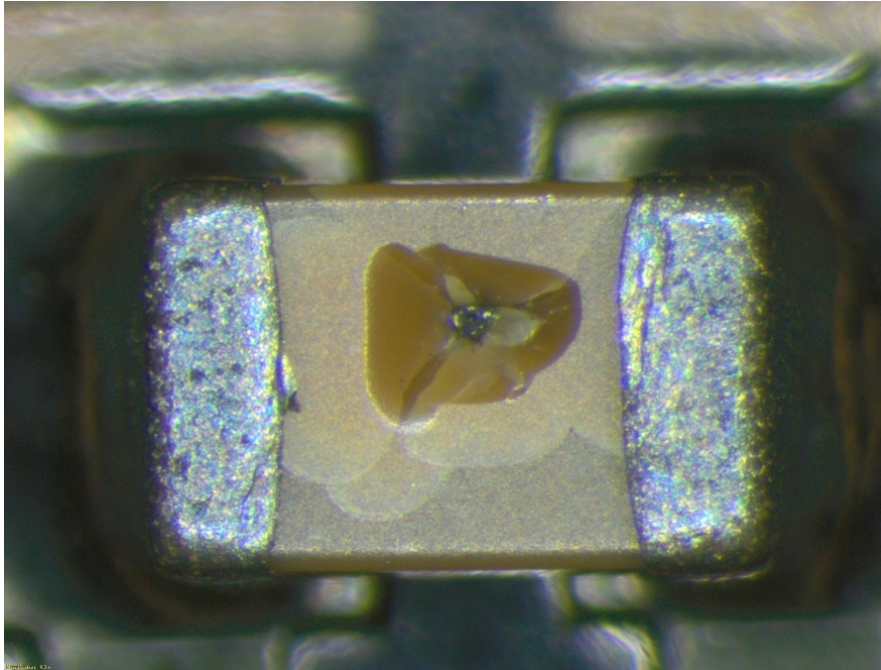

A total of 8 similar appearing catastrophic failures observed through 7500 hours of testing

# Bipolar Transistor Failure Initial Analysis Results

- X-ray Top View Showing Fused Open Bond Wire
- Testing hook-up error suspected
- Electrical over-stress likely
- Learning lessons about how to test as well as how well parts perform!!!

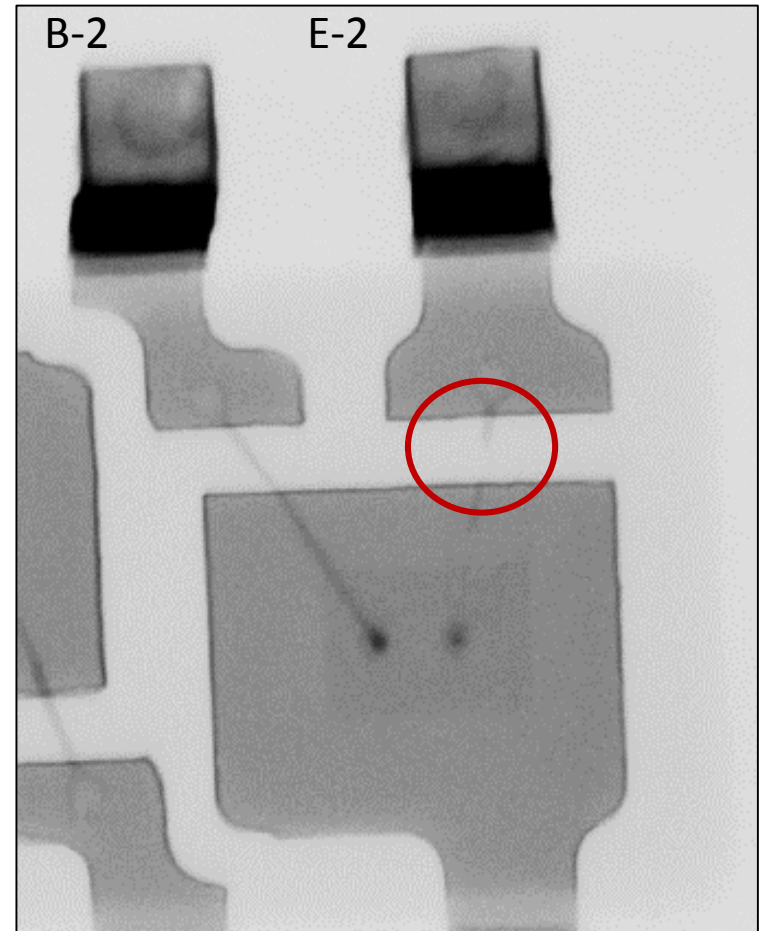

# Observations from Receiving Inspection FOD\* on IC Terminations “As-Received”

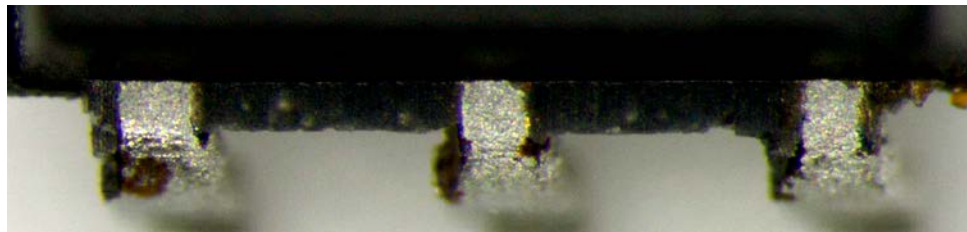
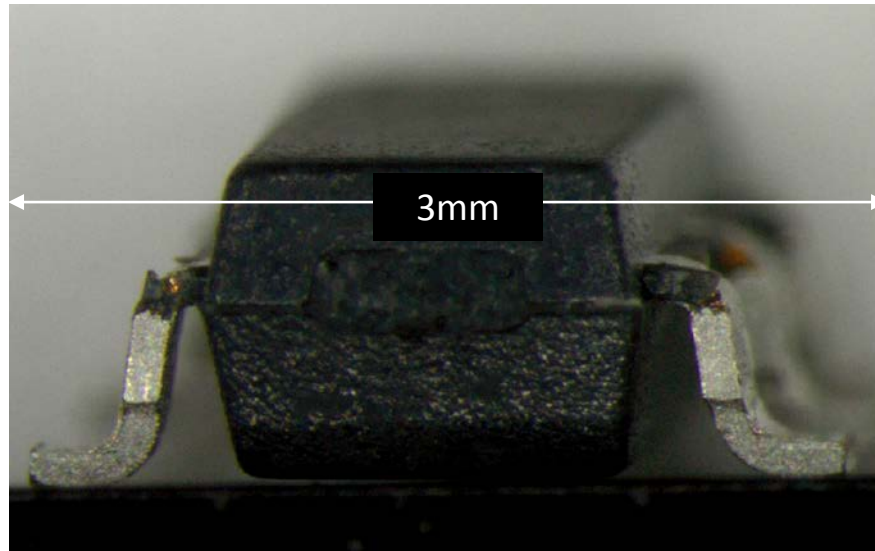

\* Excess molding compound escaping between mold halves and mold to leadframe interfaces. Small size makes it difficult to remove this flash automatically. **Considered acceptable for automotive users, NASA would normally reject to a Materials Review Board (MRB) for disposition, so NASA accept/reject criteria probably need review.**

# Digital Microcircuit Initial Failure Analysis

- Hi Speed Comparator
- All parts failed dynamic burn-in soon after turn-on
- Investigation complete
- **Parts Overstressed**
- Combination of test frequency and temperature used, exceeded part rating and led to thermal runaway
- Human Error/Learning Curve

# Lessons Learned

# Procurement of Automotive EEE Parts

## Lessons Learned (1)

- Anybody can buy catalog “AEC Q” parts via authorized distributors
- However, many large volume automotive electronic system manufacturers DO NOT buy “catalog” automotive grade EEE parts
  - Instead, they procure via internal SCDs based on “AEC Q” catalog items
  - SCDs are used to tailor and control specific needs (e.g., unique test requirements, internal part numbers)
- Some distributors demonstrated no knowledge of AEC components and suggested other parts they had in stock as replacements
- Traceability needs careful control – distributor documentation may not have same details as the manufacturer’s (such as lot codes)

# Procurement of Automotive EEE Parts Lesson Learned (2)

- Some AEC Q ceramic chip capacitors may be supplied with either “flexible termination” or “standard termination” at the discretion of the supplier.
- **Manufacturer decided to sell an equivalent part “better than” the one ordered, both were AEC qualified**
- **Not just an issue for capacitors, potential for all part types**

Mfr “A” - Flexible termination

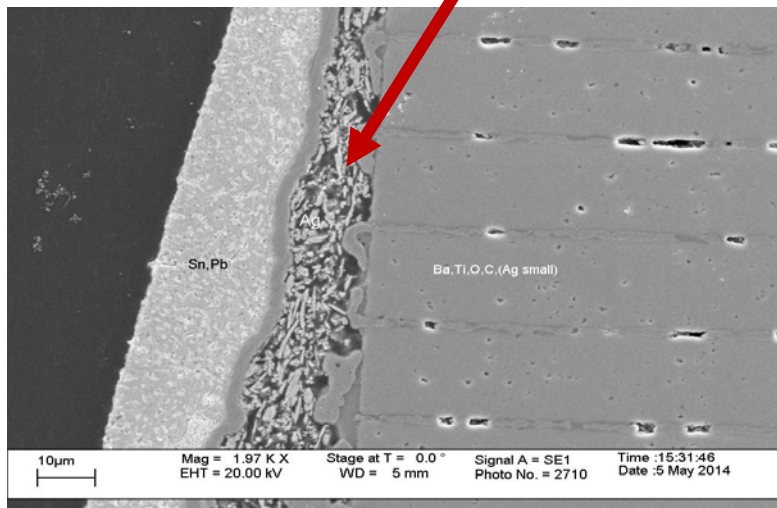

Mfr “C” - Standard termination

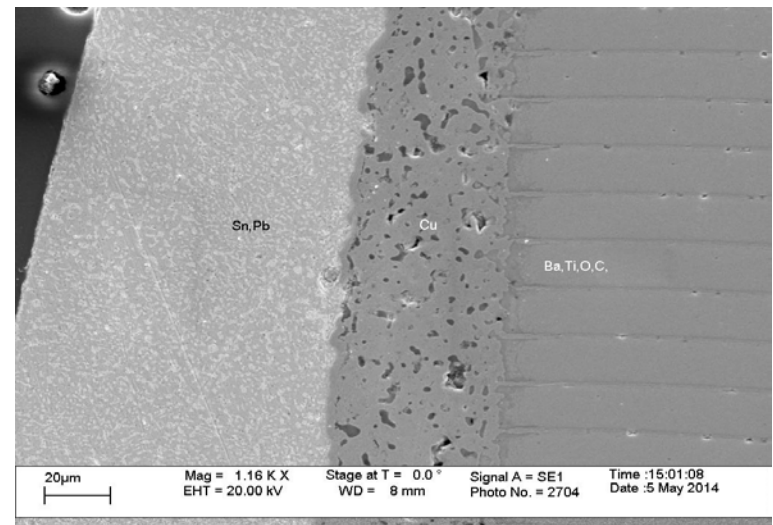

# Lessons from Testing

- So far, all parts tested, passed datasheet limits as received (basic electricals)
- Capacitor testing showed need for a bake out after DWV to “reset” capacitance
- 0805 Capacitor DPA showed different termination materials
- Many PEM's had glass transition temperatures below 125C
- Baseline electricals for 0402 were established after mounting to reduce handling of small parts
- Datasheet for digital part gave a typical value for only one electrical parameter at high temperature and testing showed actuals were about 2x this “typical” value

# General Lessons Learned

- Most AEC parts are non-hermetic but a few manufacturers provide hermetic automotive grade devices
- Device packaging is typically molded plastic, “Green Molding Compound”.
- Automotive and commercial AEC Q101 devices have implemented the use of copper bond wires instead of gold bond wires.
- Purchase costs of AEC and catalog COTS are around the same
- Pure tin finishes are allowed (possible tin whisker risk)
- Some or all manufacturing steps likely to occur in China

# Conclusions

- So far, some issues have been found and some lessons learned but no “showstoppers”
- Automotive grade EEE parts are rated for automobile environment (in cabin or under hood) – not space! However, the underlying qualification system provides a strong foundation
- The PPAP provides valuable information but content is dependent on diligence and influence of the customer
- Overall, results so far are encouraging
- The overall automotive approach to assurance of EEE parts is designed to operate with a close, two-way customer – supplier relationship

The NEPP Program acknowledges and appreciates the support to this endeavor provided by the Naval Surface Warfare Center, Crane, Indiana



# BACK-UP

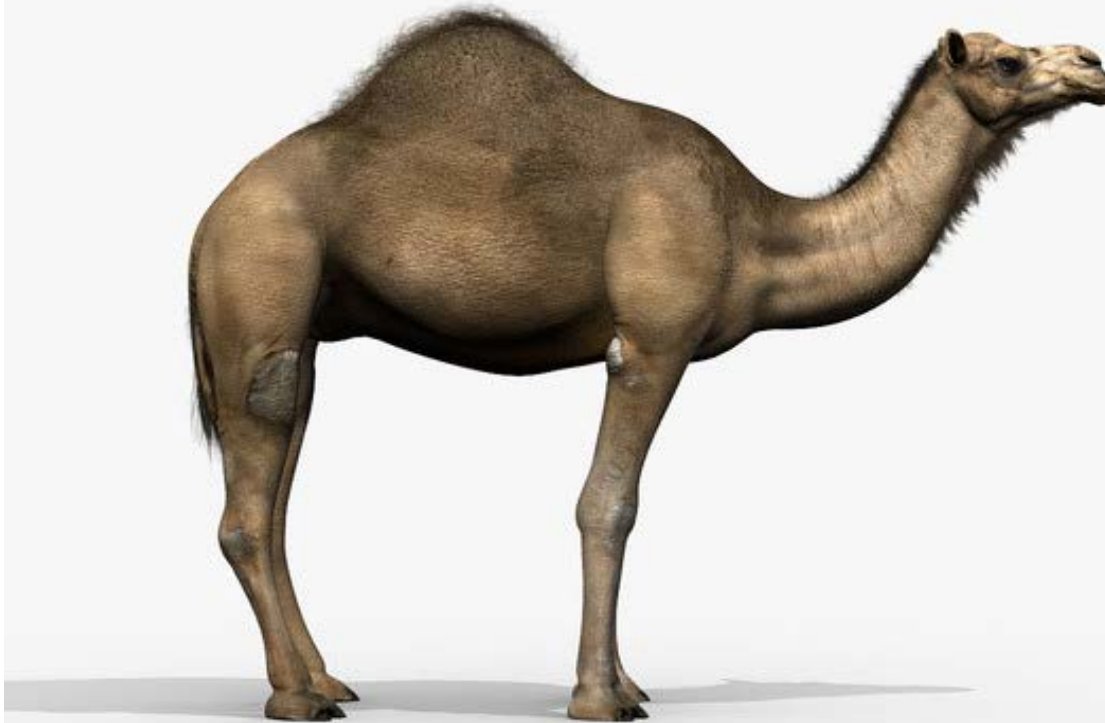

# Automotive Electronics Council (AEC)

<http://www.aecouncil.com/>

- Established early 1990s by Ford, GM, Chrysler
- Purpose to establish ***common EEE part-qualification and quality-system standards*** for use by major automotive electronics manufacturers
- Driven by desire to restore the attention given by EEE parts supplier which was declining due to the decreasing market share of automotive electronics
- Originally comprised of two committees
  - **AEC Component Technical Committee**
  - Quality Systems Committee ← **No Longer Active**

# Beyond AEC Q –

## What do SOME Automotive EEE Parts Customers Require?

- Manufacturer should be ISO TS 16949 certified (or equivalent) for Quality Management Systems for Automotive Production
  - Third party audits
  - Full assessment typically every 3 years
  - Partial assessment typically every 1 year (optional every 6 months)
- Manufacturer should follow the Automotive Industry Action Group (AIAG) Production Part Approval Process (PPAP).
- Customer audits
  - May perform an Initial Audit before adding supplier to their approved vendors lists
  - Subsequent audits may only occur when “problems arise”
- Customer-specific requirements – SCDs for automotive grade “plus”
  - Unique qualification tests
  - Unique screening tests

# Size Comparison 50V Ceramic Chip Capacitors

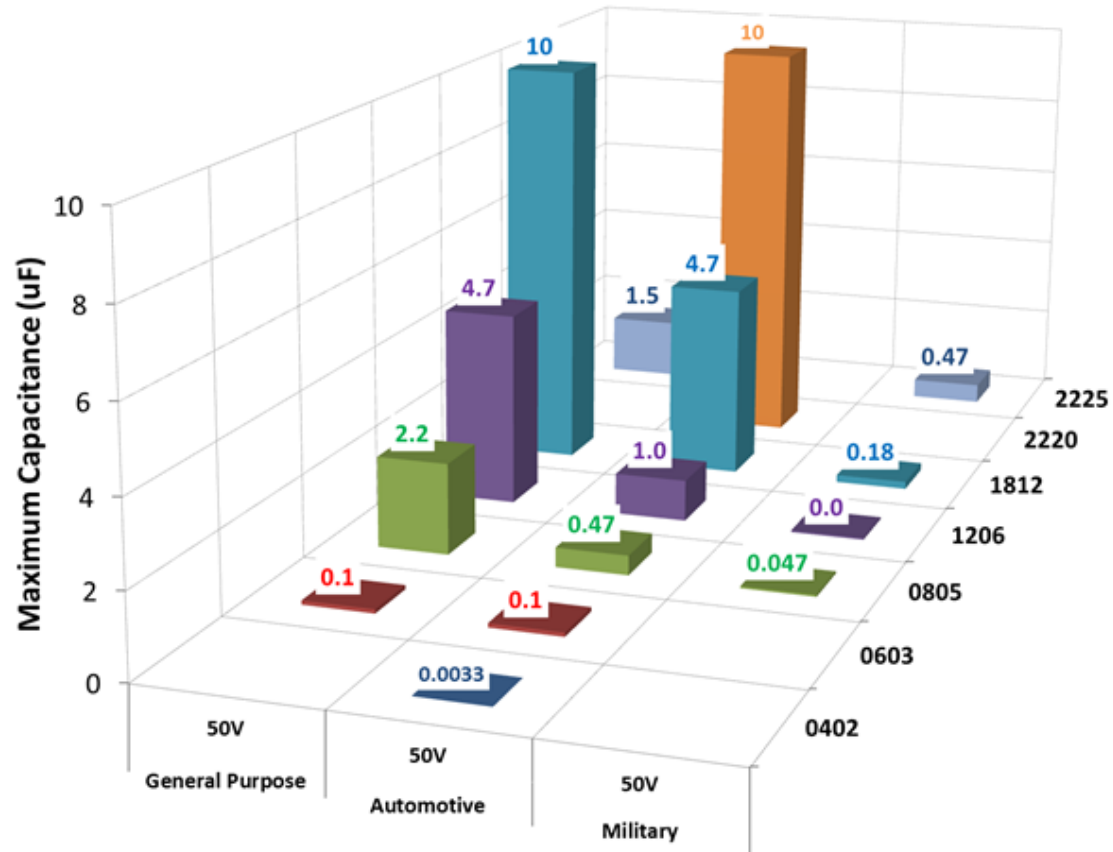

# Tantalum Chip Capacitors



## Tantalum Chip Capacitors - AVX Series (A/B/C/D/E Sizes)



AVX Catalog S-TL0M714-C

# Ceramic Chip Caps

**Ceramic Capacitor / Multilayer / Chip / SMD**  
**TDK**  
**YAGEO HCV Series**  
**YAGEO HV Series**

AVX Catalog S-MLCC0414-C

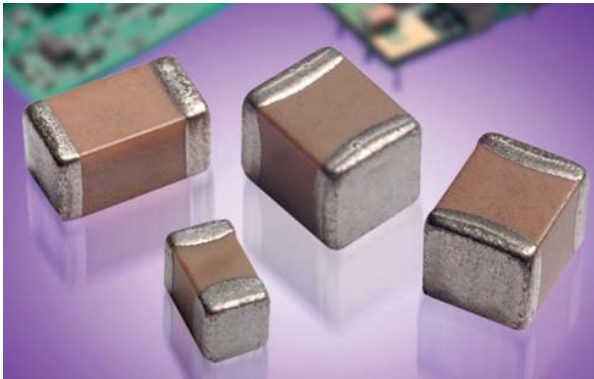

# Tantalum Chip Capacitors

## Normalized Cost Comparison for Selected Ratings

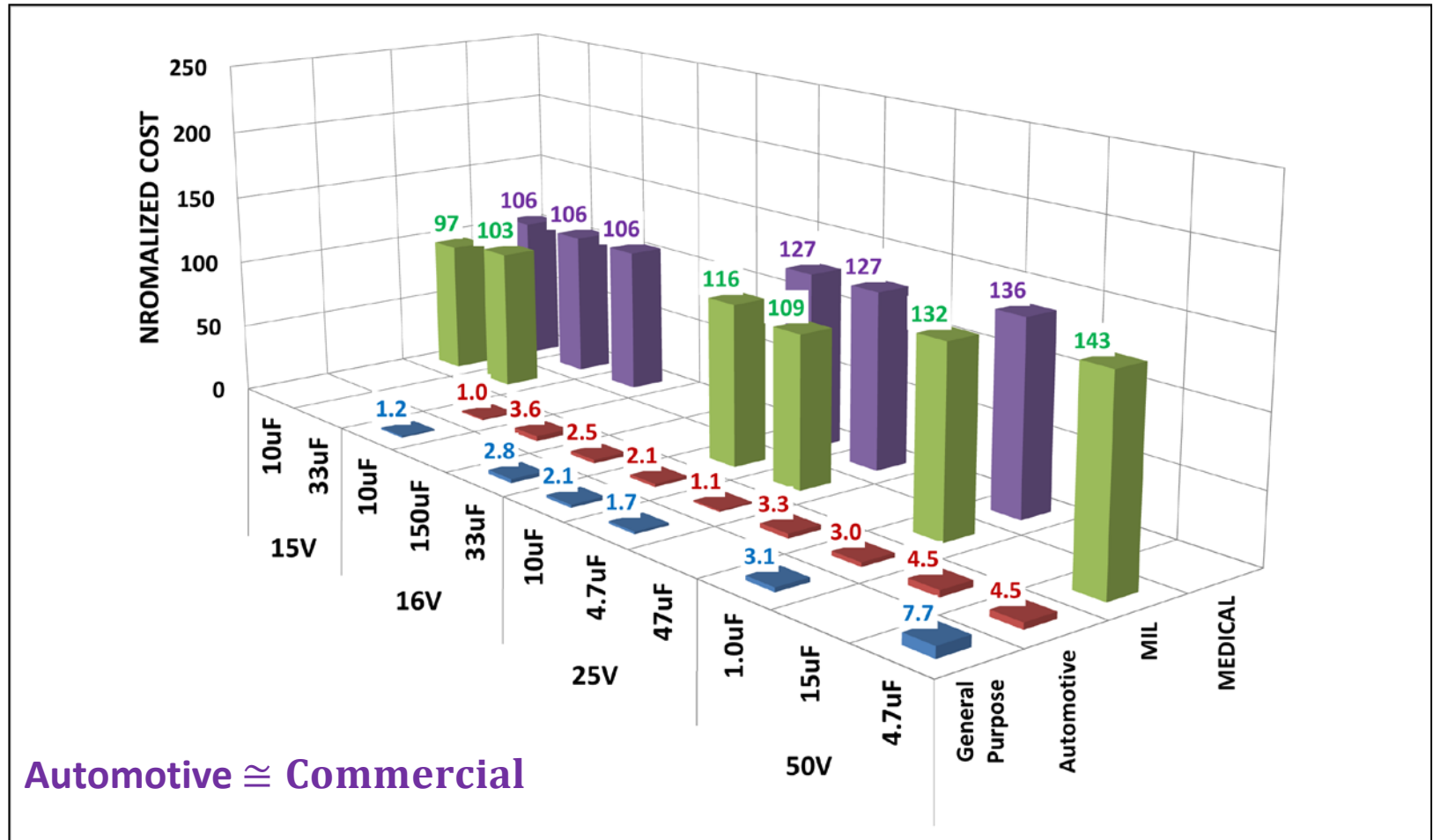

# Ceramic Chip Capacitors

Normalized Cost Comparison for Selected Ratings

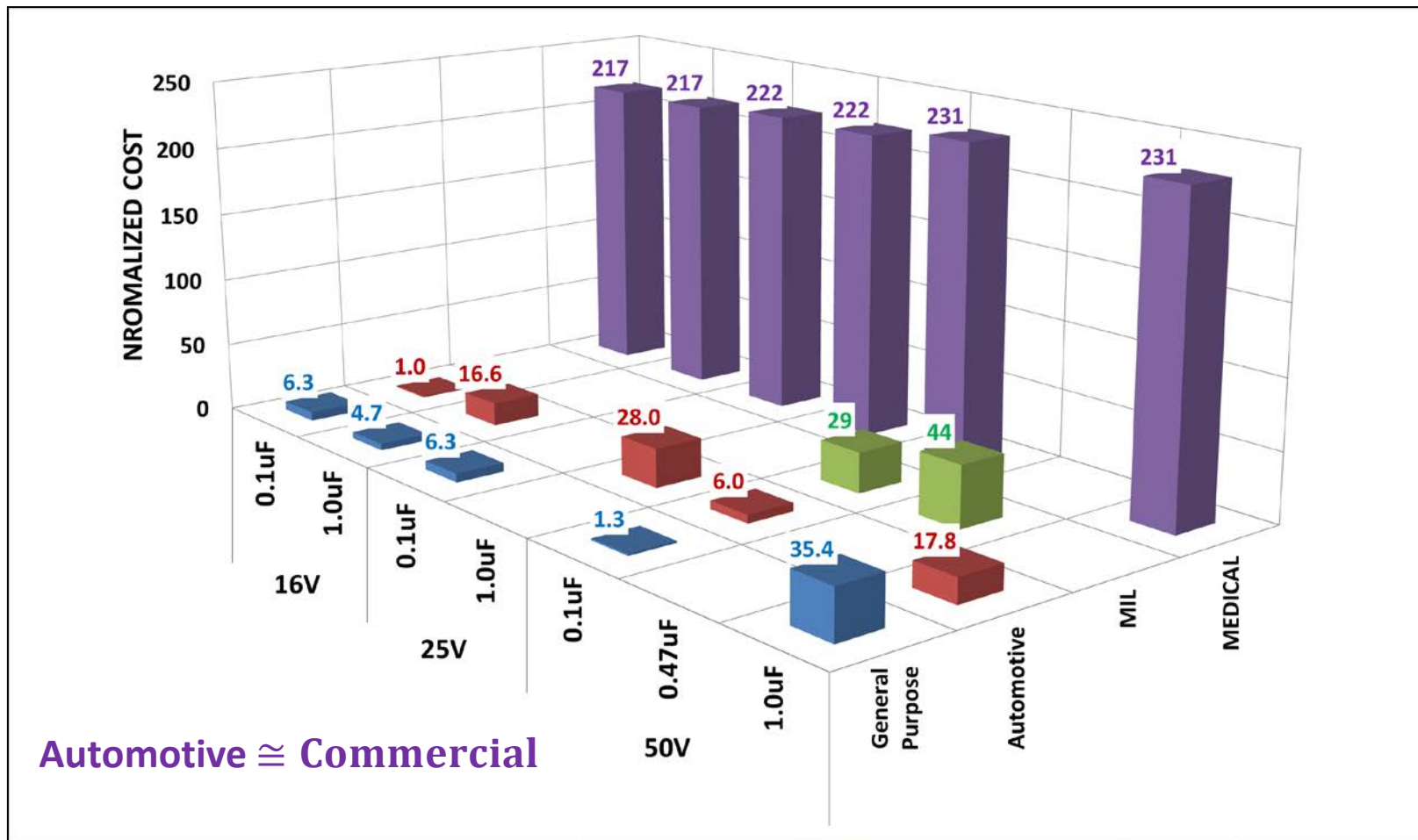

# Package Examples for 2N2222 Bipolar Transistor

## Automotive Grade

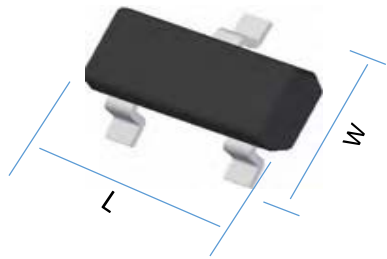

W = 2.5 mm/0.098 inch  
 H = 1.1 mm/0.043 inch  
 L = 3.0 mm/0.1181 inch

SOT-23

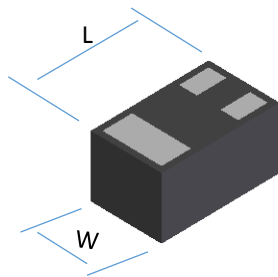

W = 0.65 mm/0.0255 inch  
 H = 0.4 mm/0.0157 inch  
 L = 1.05 mm/0.0413 inch

X2-DFN-1006-3

## Commercial Grade

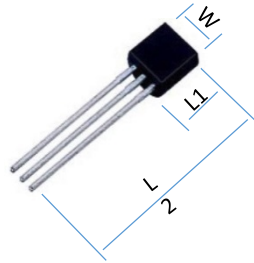

W = 5.20 mm/0.205 inch  
 H = 4.19 mm/0.165 inch  
 L1 = 5.33 mm/0.210 inch  
 L2 = 17.02 mm/0.67 inch

Plastic TO-92

## Military/Space Grade

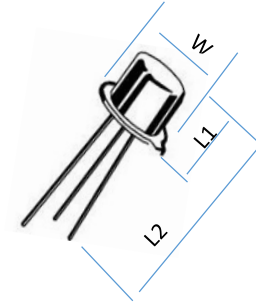

W = 5.84 mm/0.230 inch  
 L1 = 5.33 mm/0.210 inch  
 L2 = 24.384 mm/0.96 inch

Hermetic TO-18

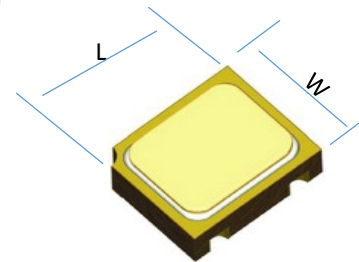

W = 5.84 mm/0.230 inch  
 H = 5.33 mm/0.210 inch  
 L = mm/ inch

Hermetic CerSOT – UB

# Package Examples for Switching Diode

## Automotive Grade

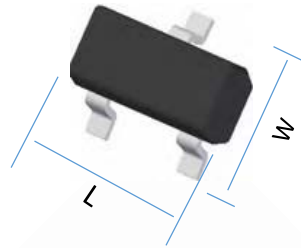

W = 2.5 mm/0.098 inch  
H = 1.1 mm/0.043 inch  
L = 3.0 mm/0.1181 inch

SOT-23

## Commercial Grade

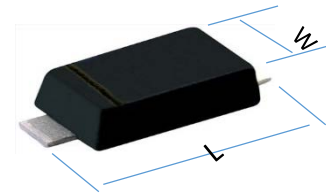

W = 0.152 mm/0.006 inch  
H = 1.1 mm/0.043 inch  
L = 3.0 mm/0.1181 inch

SOD-123

## Military/Space Grade

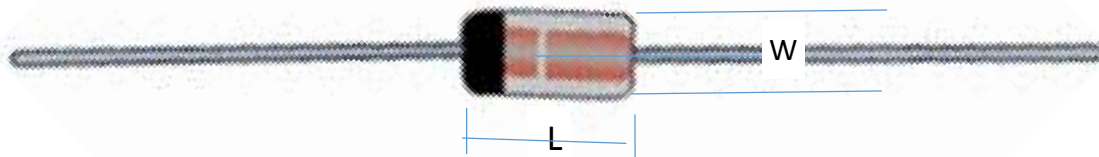

W = 1.91 mm/0.075 inch  
L = 4.57 mm/0.181 inch

DO-35

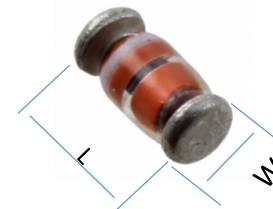

W = 1.70 mm/0.067 inch  
L = 3.71 mm/0.146 inch

UR – surface mount

# Package Examples for Schottky Barrier Diode

## Automotive Grade

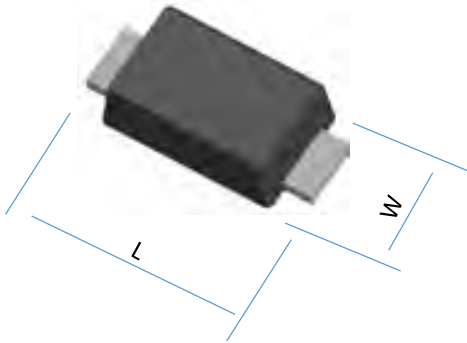

W = 1.91 mm/0.039 inch  
H = 1 mm/0.076  
L = 3.90 mm/0.1535 inch

Powerdi123

## Commercial Grade

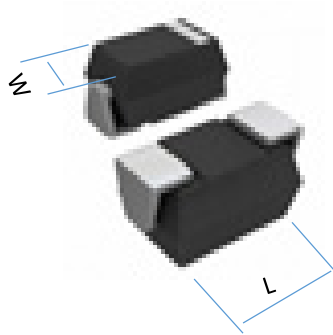

W = 2.84 mm/0.112 inch  
H = 3.15 mm/0.124  
L = 4.57 mm/0.18 inch

DO-214AC

## Military/Space Grade

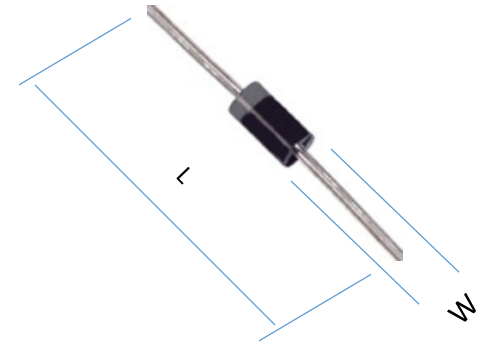

W = 1.91 mm/0.075 inch  
L = 78.10 mm/3.075 inch

DO-41



W = 2.67 mm/0.105 inch  
L = 5.21 mm/.205 inch

DO-213AB – surface mount

# What do AEC Q Specifications contain?

AEC Q specifications are Qualification Requirements Only, Focused on:

- A One-Time INITIAL QUALIFICATION of a Device Family
  - Periodic Qualification Verification NOT REQUIRED
  - Guidance is given to define what constitutes a “Device Family”
  - Specifies # of lots, qualification tests to perform and sample sizes
  - “Generic Data” may be used provided relevance of data can be demonstrated (e.g., less than 2 years old for passives)
- Requirements for REQUALIFICATION
  - Provides recommendations for requalification tests in the event certain kinds of materials or process changes are made after initial qualification
- Requirements for process change notification to automotive customers (sub-system suppliers to automotive manufacturers)
- **THEY DO NOT PROHIBIT PURE TIN – Whisker mitigation recommended**

# What do the AEC “Q” Specs *NOT* Provide?

- ***No Qualifying Activity*** to certify manufacturer meets qualification requirements
  - *Manufacturers “Self Certify” their compliance to AEC “Q”*
  - *Each User responsible to review the qualification data to verify compliance to AEC “Q”*
- **Does Not Require Supplier Quality Audits**
  - In practice, most EEE component manufacturers are certified to ISO TS 16949
  - Does Not Require SCREENING to remove infant mortality or quality defects
  - *Screening is at discretion of each manufacturer and as such is Not Standardized across the manufacturer base and may also be customer specific*
- **Does Not Provide Standard Specifications nor Part Numbers for Procurement**
  - Manufacturers choose their “automotive grade” designs and part numbers