

Kennedy Space Center

Dynamic Gas Flow Effects on the ESD of Aerospace Vehicle Surfaces

Michael D. Hogue, PhD, NASA Kennedy Space Center

Jayanta Kapat, PhD, University of Central Florida

Kareem Ahmed, PhD, University of Central Florida

Rachel E. Cox, NASA, Kennedy Space Center

Jennifer G. Wilson, NASA, Kennedy Space Center

Luz M. Calle, PhD, NASA, Kennedy Space Center

Jaysen Mulligan, University of Central Florida



Kennedy Space Center

Agenda

- Introduction
- Theoretical Development
 - Paschen's Law
 - Paschen's Law derived with the Mach number
 - Paschen's Law derived with the Mach number and dynamic pressure terms
 - Paschen's law derived with dynamic pressure terms only
 - A hypothesized effective discharge distance
- Proposed Experiment
 - CATER wind tunnel
 - Electrode and test section design
 - Progress to date
- Future work
- Summary

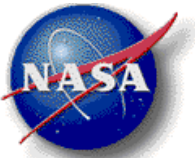

Kennedy Space Center

Introduction

- The purpose of this work is to develop a form of Paschen's law that takes into account the flow of gas past electrode surfaces.
- In 2010 the Electrostatics and Surface Physics Laboratory (ESPL) at the Kennedy Space Center performed an electrostatic safety analysis on the flight termination system (FTS) antenna for the Ares I rocket.
- Paschen's law, derived by Friedrich Paschen in 1889, does not take into account the effects of flowing gas on the concentration of electron – ion pairs between the electrodes.
- The safety of the FTS housing to triboelectric charging was shown only after extensive laboratory testing.

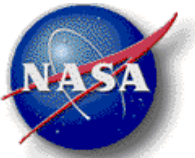

Kennedy Space Center

Introduction

- Potential benefits of a form of Paschen's law that considers gas velocity.
 - Possible relaxation of electrostatic launch criteria. Launch aborts cost around a million US dollars.
 - Better anti-static coatings may be developed from this data.
- This work is being performed under a NASA Science Innovation Fund (SIF) project at the Kennedy Space Center.

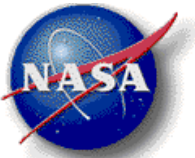

Kennedy Space Center

Theoretical Development

- We have theoretically derived three candidate versions of Paschen's law.
- One is using a Mach number formulation.
- Another is a Mach number formulation with dynamic pressure terms.
- The third is a formulation that uses dynamic pressure terms only.
- This theoretical effort is a first approximation at a generalized form of Paschen's law to include gas velocity.

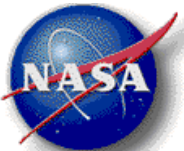

Paschen's Law

Kennedy Space Center

- Paschen's law

$$V_s = \frac{\frac{V_i}{LP_{atm}} Pd}{\ln(Pd) - \ln \left[LP_{atm} \ln \left(1 + \frac{1}{\gamma} \right) \right]}$$

- Nomenclature:
 - V_s Sparking discharge voltage (V)
 - V_i Ionization potential of the ambient gas (V)
 - P Gas pressure (torr)
 - d Electrode separation (cm)
 - P_{atm} Atmospheric pressure at sea level (760 torr)
 - L Mean free path at sea level (6.8×10^{-6} cm)
 - γ Secondary electron emission coefficient of the electrode metal

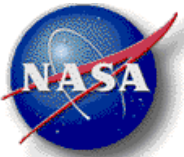

Mach Number Formulation

Kennedy Space Center

- Hypothesis: The loss of electron – ion pairs due to gas velocity can be expressed by a dimensionless aerodynamic term such as the Mach number.
- The model equation must revert to Paschen's law when $v_{xm} = 0$.
- The Mach number is the ratio of the mean gas velocity to the speed of sound, $M_N = v_{xm}/c$. Here $c = 319$ m/s at sea level.

$$V_s = \frac{\frac{V_i}{LP_{atm}}(Pd)}{\ln(Pd) - \ln\left[LP_{atm} \ln\left(1 + \frac{1}{\gamma}\right)\right] - M_N}$$

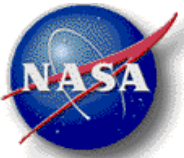

Comparison Graph of Paschen's Law and the First Model Equation (Mach Number term)

Kennedy Space Center

Gap: 1.0 cm, Gas: air, Gas velocity: Mach 1.9 (600 m/s), Electrodes: Aluminum ($\gamma = 0.035$)

Paschen Curve (Air with Al Electrodes, Mach 1.9)

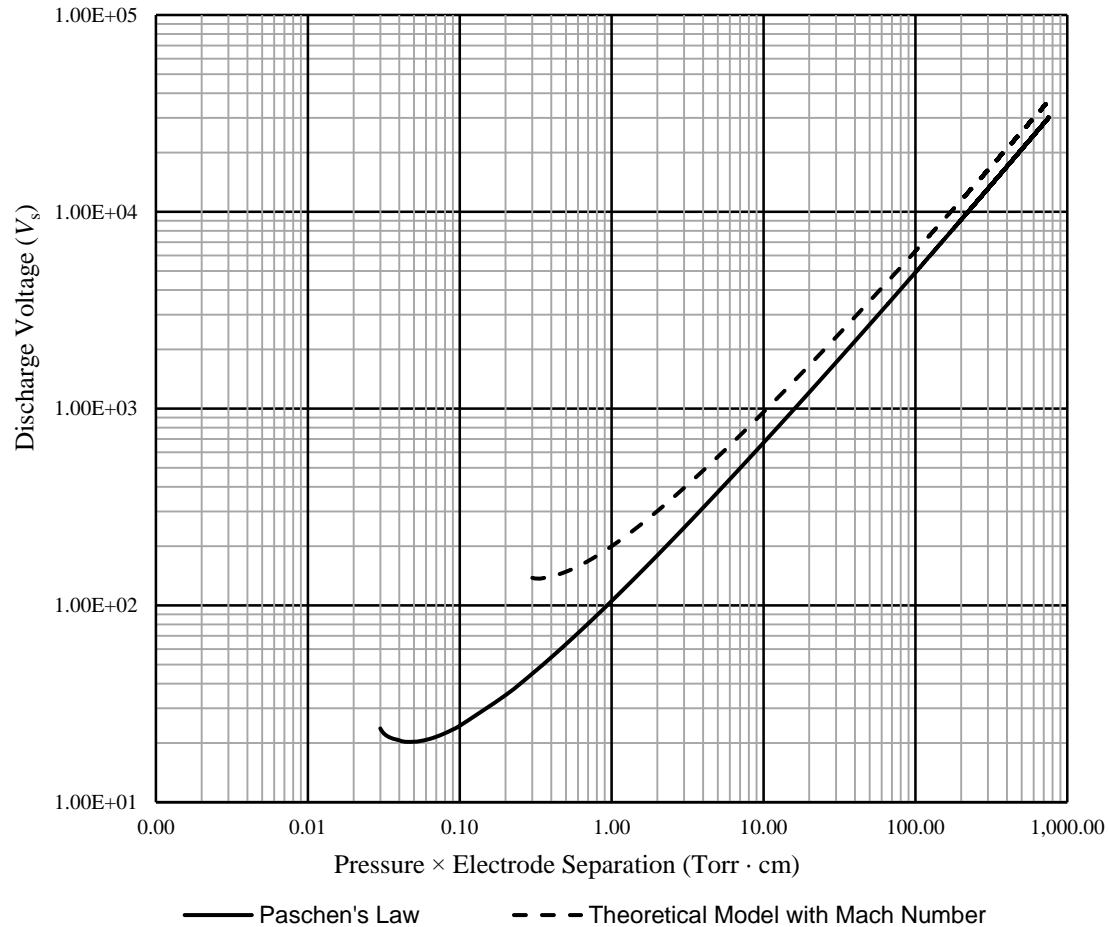

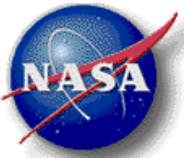

Mach Number and Dynamic Pressure Formulation

Kennedy Space Center

- For moving vehicles, pressure has two components

- Static pressure: P_0

- Dynamic pressure: $P_D = \frac{1}{2} \rho v_{xm}^2$

- Total pressure

$$P = P_0 + P_D = P_0 + \frac{1}{2} \rho v_{xm}^2$$

- Use the ideal gas law:

$$P_0 \nabla = nRT \quad \longrightarrow \quad P_0 \nabla = \left(\frac{W}{M} \right) RT \quad \longrightarrow \quad \frac{P_0 M}{RT} = \frac{W}{\nabla} = \rho$$

Where M is the molecular weight and $W = nM$ (mass of gas).

- This gives for the total pressure

$$P = P_0 + \frac{1}{2} \frac{P_0 M}{RT} v_{xm}^2 = P_0 \left(1 + \frac{1}{2} \frac{M}{RT} v_{xm}^2 \right)$$

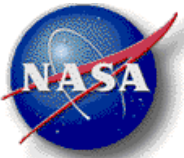

Mach Number and Dynamic Pressure Formulation

Kennedy Space Center

- Substituting in the total pressure in the model equation gives

$$V_s = \frac{\frac{V_i}{LP_{atm}} \left(1 + \frac{1}{2} \frac{M}{RT} v_{xm}^2 \right) P_0 d}{\ln \left[\left(1 + \frac{1}{2} \frac{M}{RT} v_{xm}^2 \right) P_0 d \right] - \ln \left[LP_{atm} \ln \left(\frac{1}{\gamma} + 1 \right) \right] - M_N}$$

- This equation also meets the criteria that Paschen's law is returned when the mean gas velocity is zero.



Comparison of Paschen's Law to the Model Equation with Mach Number and Dynamic Pressure Terms

Kennedy Space Center

Gap: 1.0 cm, Gas: air, Gas velocity: Mach 1.9 (600 m/s), Electrodes: Aluminum ($\gamma = 0.035$)

Paschen Curve M_N & Dynamic Pressure (Air with Al Electrodes, Mach 1.9)

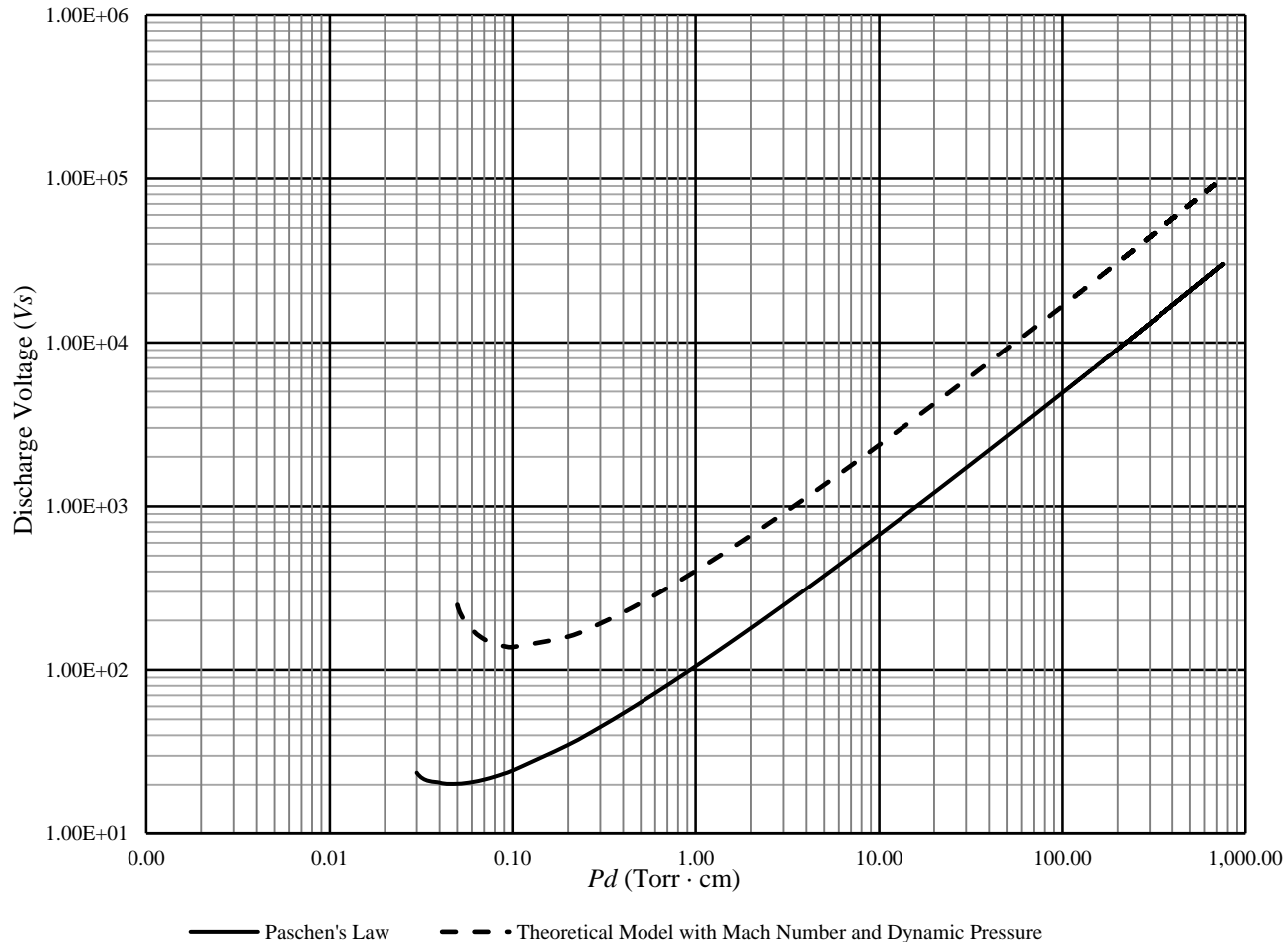

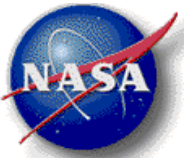

Mach Number and Dynamic Pressure Formulation

Kennedy Space Center

- Paschen's law is a function of the product of P and d .
- The model equation with Mach number and dynamic pressure terms is a function of P , d , v_{xm} , and T .

$$V_S = f(P, d, v_{xm}, T)$$

- The graph shows a larger separation between Paschen's law and the model equation with Mach number and dynamic pressure terms.
- This larger separation will be more difficult to test since at atmospheric pressure the model equation calculates a sparking voltage of $\sim 90\text{kV}$.

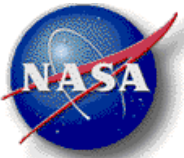

A Hypothesized Effective Discharge Path

Kennedy Space Center

Gap: 4.4 cm, Gas: air, Gas velocity: Mach 1.9, Temperature: 300 K

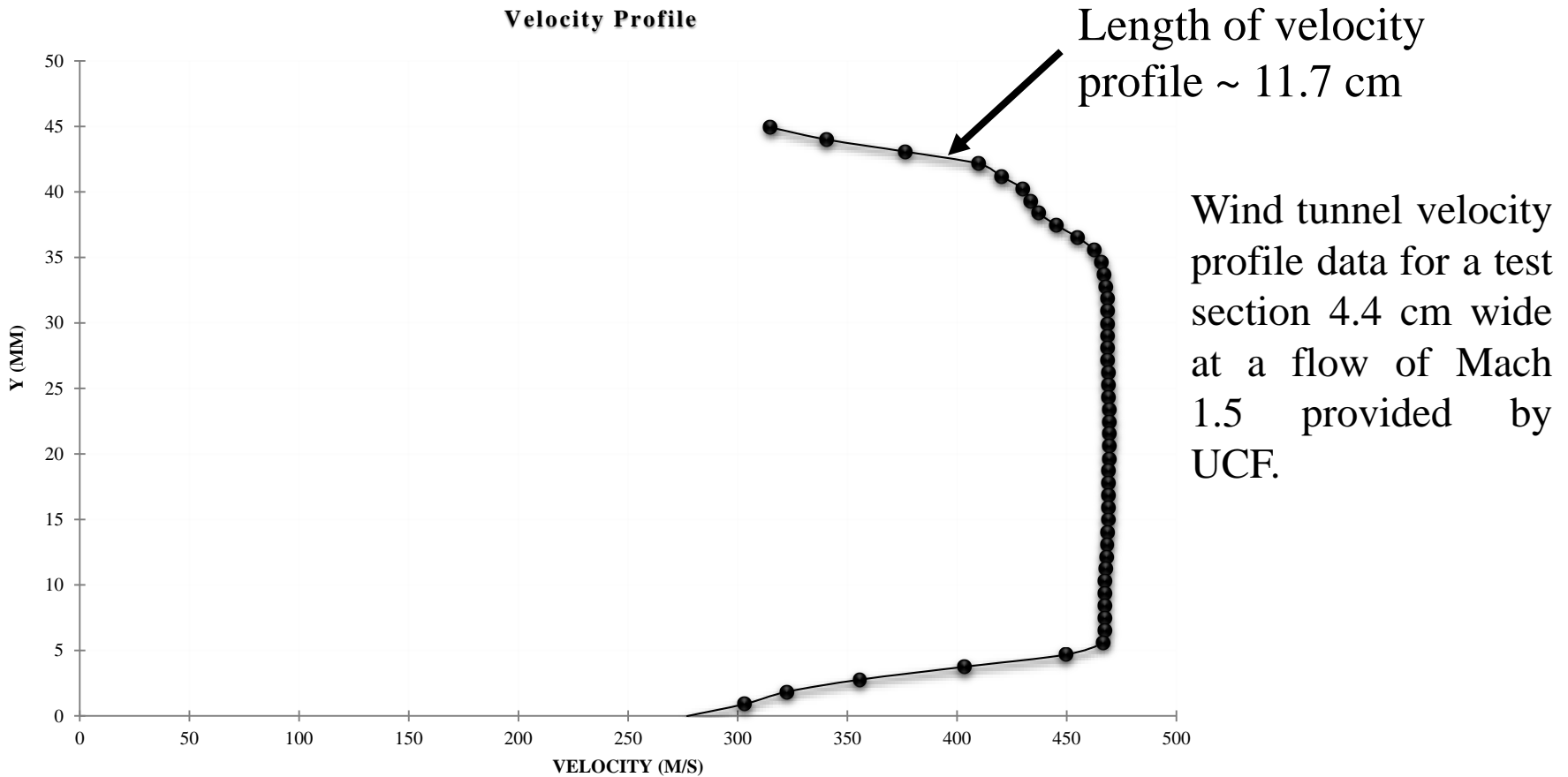

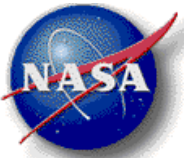

Paschen Curve Comparison, Mach Number & Dynamic Pressure Terms with Velocity Profile Data

Kennedy Space Center

Gas: air, Gap: 4.4 cm, Mean velocity: Mach 1.5, T: 300 K

Paschen Curve Comparison, Mach Number & Dynamic Pressure Terms

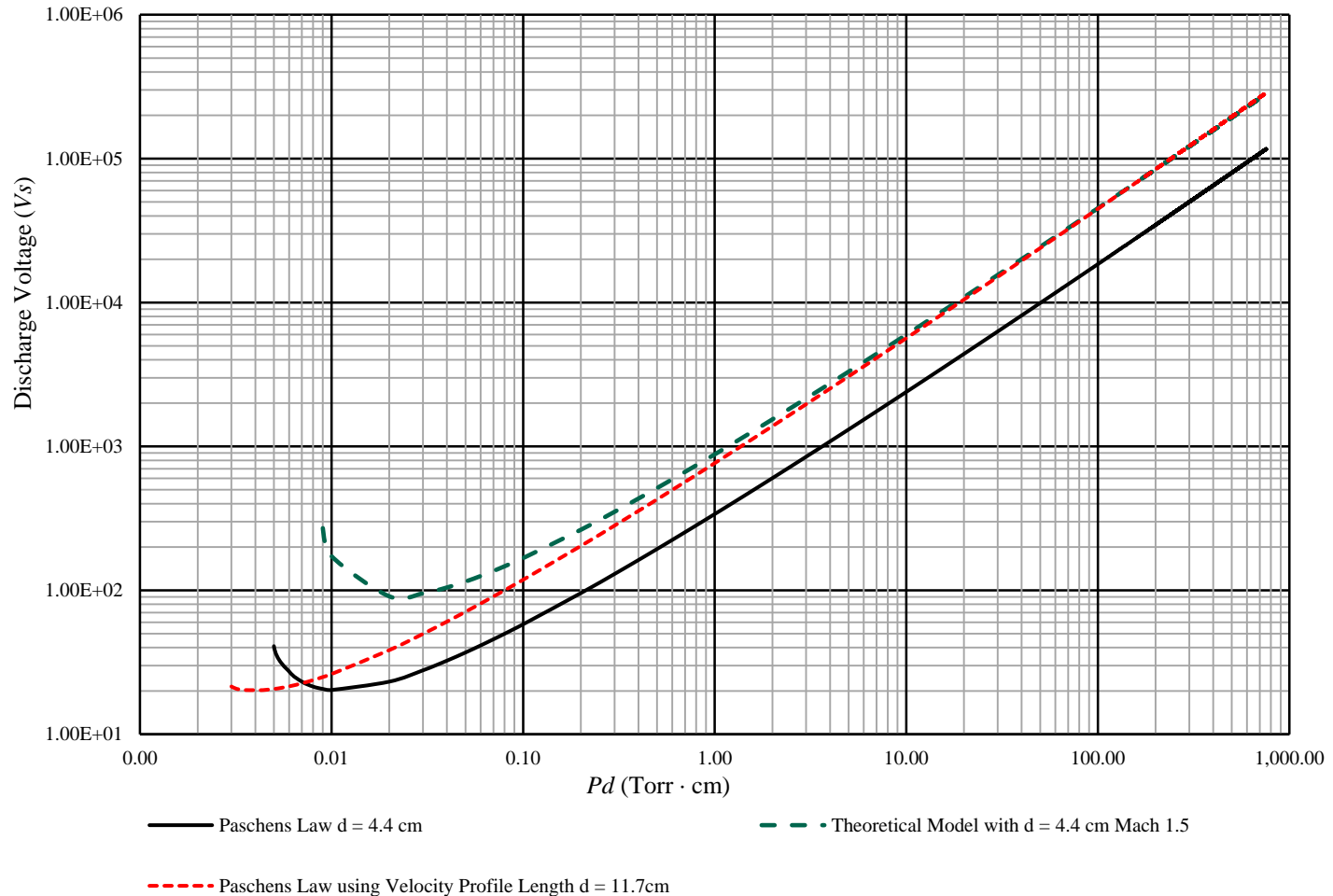

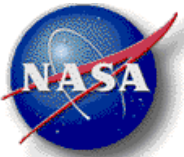

Kennedy Space Center

Model Equation with Dynamic Pressure Terms Only

- The model equation was revised to have only dynamic pressure terms.

$$V_s = \frac{\frac{V_i}{LP_{atm}} \left(1 + \frac{1}{2} \frac{M}{RT} v_{xm}^2 \right) P_0 d}{\ln \left[\left(1 + \frac{1}{2} \frac{M}{RT} v_{xm}^2 \right) P_0 d \right] - \ln \left[LP_{atm} \ln \left(\frac{1}{\gamma} + 1 \right) \right]}$$

- This equation was plotted with Paschen curves for gaps of 4.4 cm and 11.7 cm.

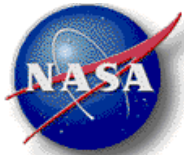

Kennedy Space Center

Comparison of Paschen Curves with the Model Equation with Dynamic Pressure Terms only.

Paschen Curve Comparison, T = 300K

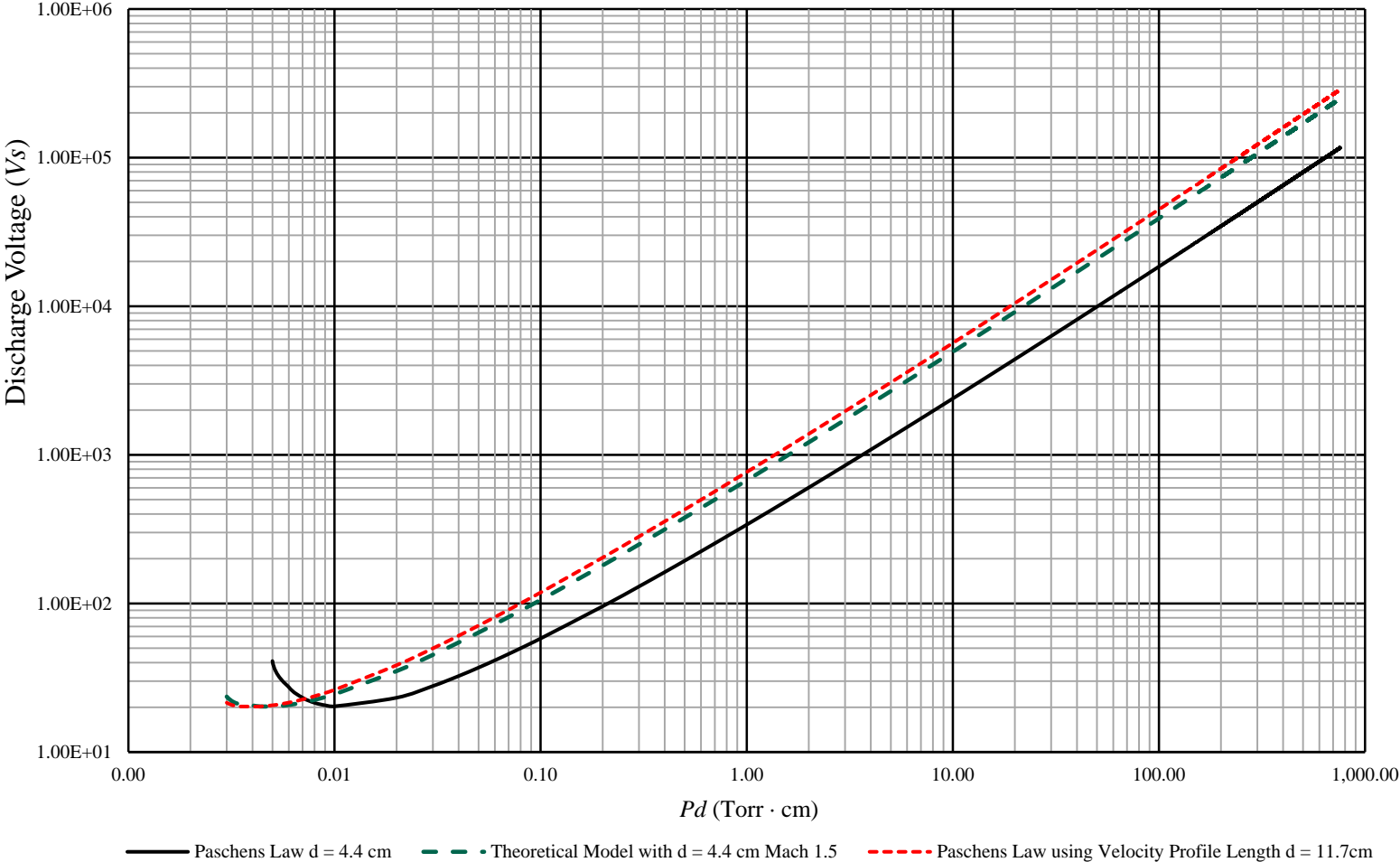

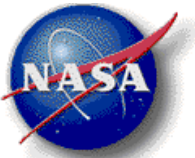

Kennedy Space Center

Effective Discharge Distance

- From inspection of the model equation with dynamic pressure terms only, we hypothesize an effective discharge distance due to the gas velocity.

$$d' = \left(1 + \frac{1}{2} \frac{M}{RT} v_{xm}^2 \right) d$$

- More wind tunnel data for different test section widths and Mach numbers is needed to analyze this result adequately.

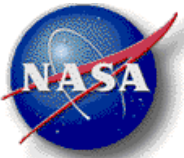

Proposed Experiment

Kennedy Space Center

The Center for Advanced Turbomachinery and Energy (CATER) at UCF.

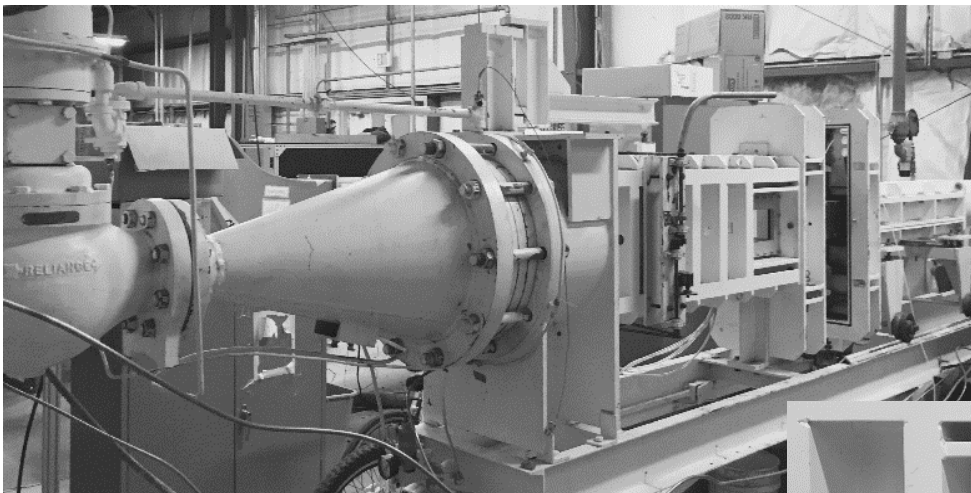

Wind tunnel is capable of low Mach number operation.

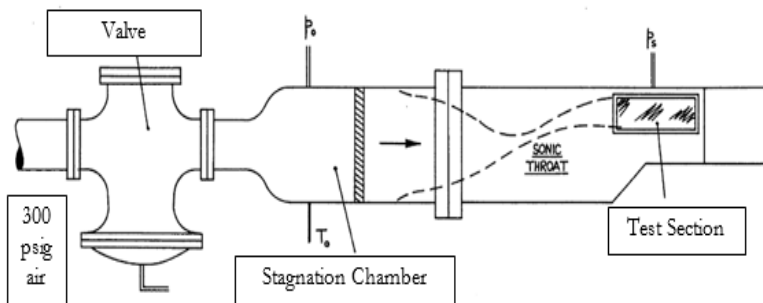

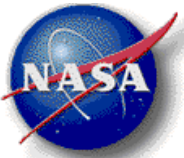

Proposed Experiment

Kennedy Space Center

High level schematic of the CATER wind tunnel experiment to measure the electrical discharge of high speed gas flow past electrodes.

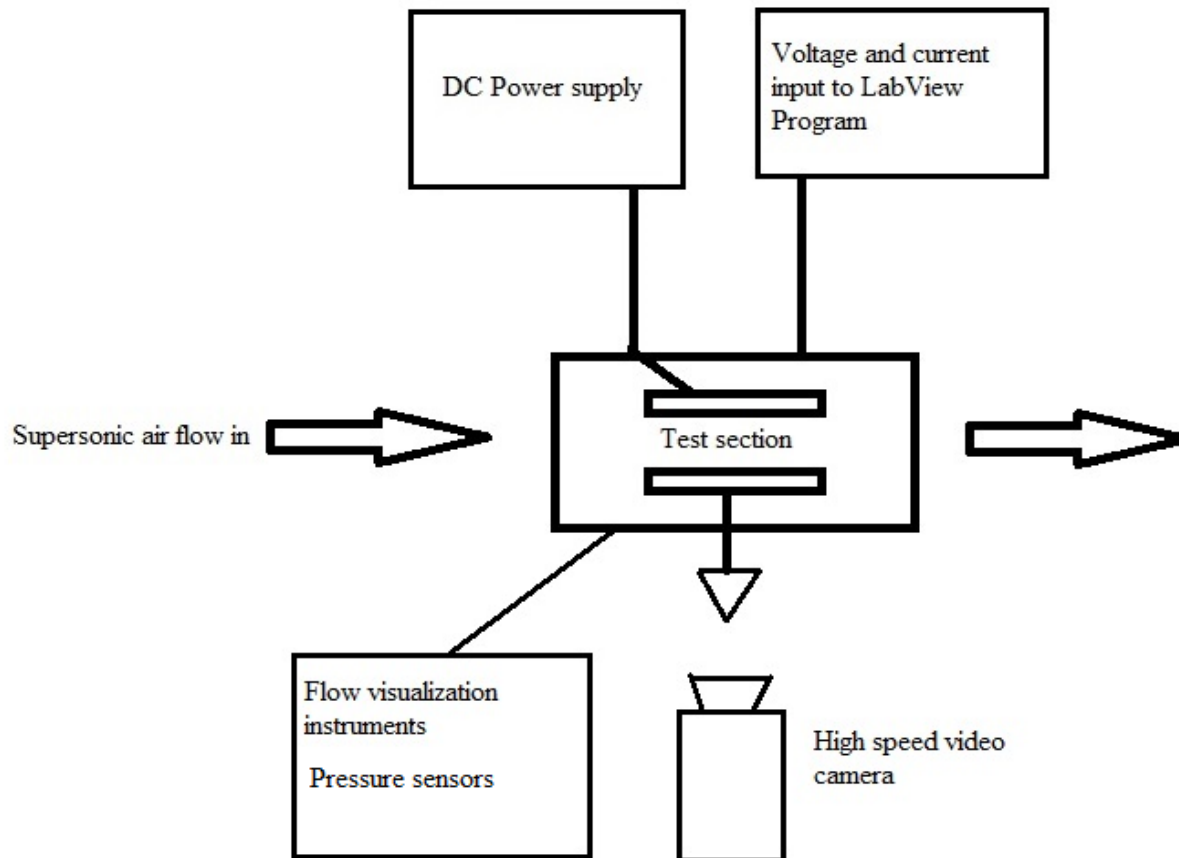

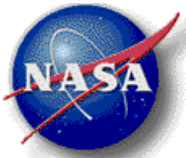

Proposed Experiment

Kennedy Space Center

Preliminary experimental concept showing test section and electrode placement.

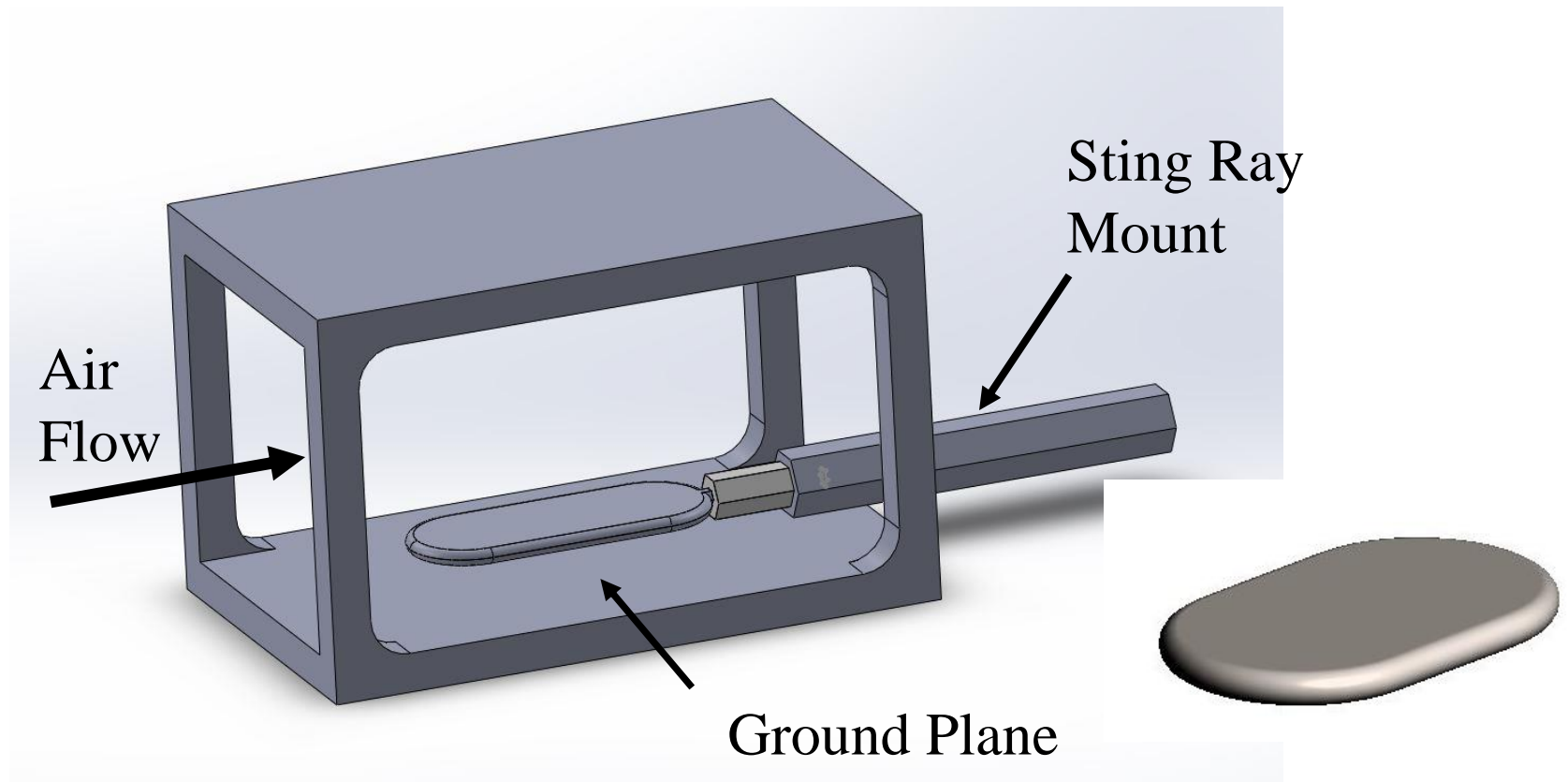

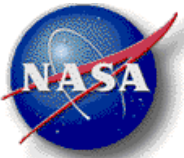

Future Work

Kennedy Space Center

- Investigate pressure dependence of the speed of sound.

- $\gamma_a = C_p/C_v = 1.4$.

- ρ is the gas density.

$$c = \sqrt{\gamma_a \frac{p}{\rho}} = \sqrt{\frac{\gamma_a RT}{M}}$$

- Velocity profiles require a pressure gradient to exist or dP/dy .
- Further analyze the hypothesis that dynamic pressure terms in the model equation are an effective discharge path between the electrodes.

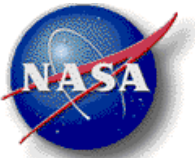

Kennedy Space Center

Summary

- Three model equations based on Paschen's law were developed to account for the effect of gas flow on the sparking voltage.
- An effective discharge distance due to gas velocity was hypothesized based on preliminary theoretical models and wind tunnel test data.
- A wind tunnel experiment is being developed to test the model equations.