

# Space Synthetic Biology Project

## Project Manager(s)/Lead(s)

David Howard/FP10  
(256) 544-5169

Monsi Roman/FP10  
(256) 544-4071

James (Matt) Mansell/ES62  
(256) 544-8297

## Sponsoring Program(s)

Space Technology Mission Directorate  
Game Changing Development

## Project Description

Synthetic biology is an effort to make genetic engineering more useful by standardizing sections of genetic code. By standardizing genetic components, biological engineering will become much more similar to traditional fields of engineering, in which well-defined components and subsystems are readily available in markets. Specifications of the behavior of those components and subsystems can be used to model a system which incorporates them. Then, the behavior of the novel system can be simulated and optimized. Finally, the components and subsystems can be purchased and assembled to create the optimized system, which most often will exhibit behavior similar to that indicated by the model.

The Space Synthetic Biology project began in 2012 as a multi-Center effort. The purpose of this project was to harness Synthetic Biology principals to enable NASA's missions. A central target for application was to Environmental Control & Life Support (ECLS). Engineers from NASA Marshall Space Flight Center's (MSFC's) ECLS Systems Development Branch (ES62) were brought into the project to contribute expertise in operational ECLS systems.

Project lead scientists chose to pursue the development of bioelectrochemical technologies to spacecraft life support. Therefore, the ECLS element of the project became essentially an effort to develop a bioelectrochemical ECLS subsystem. Bioelectrochemical systems exploit the ability of many microorganisms

to drive their metabolisms by direct or indirect utilization of electrical potential gradients. Whereas many microorganisms are capable of deriving the energy required for the processes of interest (such as carbon dioxide (CO<sub>2</sub>) fixation) from sunlight, it is believed that subsystems utilizing electrotroths will exhibit smaller mass, volume, and power requirements than those that derive their energy from sunlight.

In the first 2 years of the project, MSFC personnel conducted modeling, simulation, and conceptual design efforts to assist the project in selecting the best approaches to the application of bioelectrochemical technologies to ECLS. Figure 1 shows results of simulation of charge transport in an experimental system. Figure 2 shows one of five conceptual designs for ECLS subsystems based on bioelectrochemical reactors. Also during the first 2 years, some work was undertaken to gather fundamental data (conductivities, overpotentials) relevant to the modeling efforts.

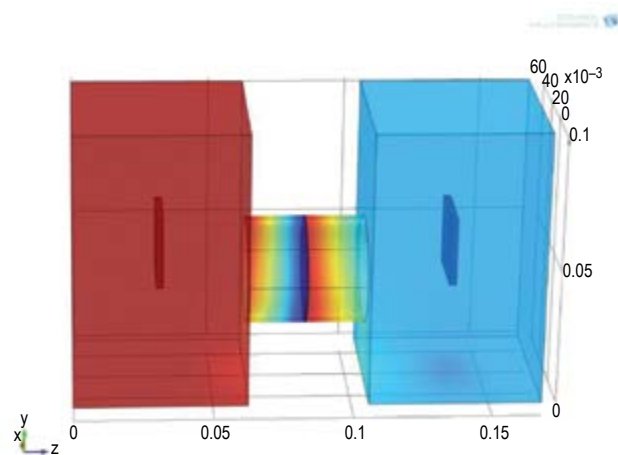

**Figure 1: Results of a simulation showing proton concentration in a bioelectrochemical test cell.**

In fiscal year 2014, MSFC personnel proposed to conduct development efforts on critical components of the bioelectrochemical ECLS subsystem which had not yet been investigated but which would be critical to operation of the subsystem. (All of the focus of the technical development efforts of the project to this point had been on the reactor itself.) Drawing on the conceptual design efforts of the first 2 years, MSFC identified three

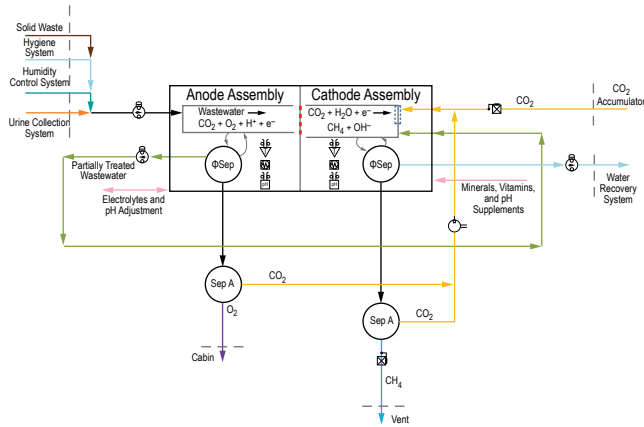

**Figure 2: A process diagram of a concept design for a bioelectrochemical ECLS subsystem.**

critical components and elected to develop technologies for CO<sub>2</sub> injection, i.e., an efficient, microgravity-compatible method of dissolving CO<sub>2</sub> into the aqueous electrolyte so that the CO<sub>2</sub> can be reacted to useful products in the reactor.

Project personnel at MSFC proceeded to design a test system to evaluate technologies for the CO<sub>2</sub> injection component, and the system was assembled in the ECLS Systems Laboratory, Bldg. 4755. Considerable effort was required to a methodology for sampling and analyzing to quantify dissolved carbon. Ultimately, a procedure involving preparation of sealed dilution vials, sample collection via syringe, and analysis in a total organic carbon analyzer was developed. This method proved less accurate than desirable, but was sufficient to provide some degree of comparison of performance under differing conditions.

A gas-liquid contact membrane was tested by exposing an aqueous solution of known composition, at known temperature, pressure, and flow rate, to CO<sub>2</sub> gas at known pressure across the contactor. Gas pressure, liquid pressure, and liquid flow rate were varied between trials. Results were plotted as curves, and reported, in order to guide sizing of such a technology for CO<sub>2</sub> injection in a future bioelectrochemical CO<sub>2</sub> reduction/fixation subsystem. Some of the results are shown in figure 3.

### **Anticipated Benefits**

The bioelectrochemical subsystem developed under the Space Synthetic Biology project is targeting an application wherein the subsystem decreases the load on the

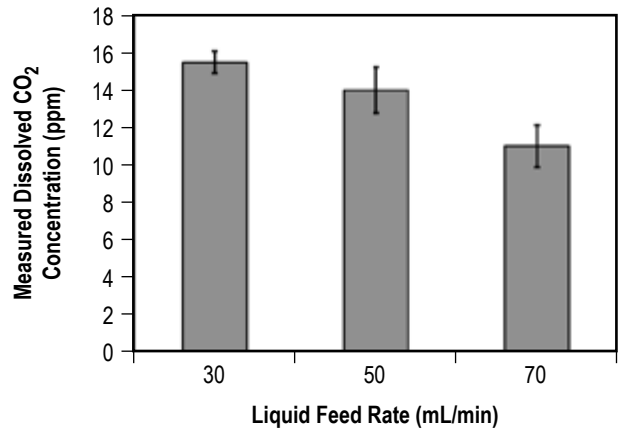

**Figure 3: CO<sub>2</sub> injection performance results from a gas-liquid contactor.**

primary urine processor and CO<sub>2</sub> reduction subsystem, and simultaneously produces an organic precursor, which would then be utilized to manufacture a range of high-value organic products, including food, bioplastics, and pharmaceuticals.

The electrochemical modeling expertise developed and lessons learned in the early phases of the project at MSFC could benefit future development efforts for various electrochemical ECLS technologies, and the equipment, methodologies, and expertise built up may prove valuable to other subsystem development efforts relying on dissolved CO<sub>2</sub>.

### **Potential Applications**

Advanced ECLS development efforts within the Agency may elect to pursue development of the bioelectrochemical reactor technology for application to extended-duration, crewed missions beyond low-Earth orbit. The CO<sub>2</sub> injection test system may be applied to optimization of gas handling in a range of ECLS subsystems requiring handling of dissolved gases in microgravity, including algae-based air and water processors.

### **Notable Accomplishments**

Notable accomplishments include the development and evaluation of five concept designs for ECLS subsystems based around bioelectrochemical reactors, the assembly of a test stand to evaluate CO<sub>2</sub> injection technologies, and reporting results of the evaluation of a gas-liquid contactor for this application.