

Challenges of Designing a 13-Hz High-Load Vibration Isolation System with Tight Volume Constraints: Lessons Learnt and Path Forward

Stella Dearing* and Dale Ruebsamen*

Abstract

This paper describes the design of a passive isolation system using D-struts® to isolate an optical payload from aircraft-borne jitter with challenging stroke per volume requirements. It discusses the use of viscoelastic-coated D-struts® that meet the customer performance and outgassing specification, NASA-1124. The result was a relatively soft isolation system, (where the first mode was 13 Hz), with each individual strut capable of withstanding loads on the order of magnitude of 623 N (140 lbf), weighing less than 910 g (2 lbm), fitting in a volume 5.1 cm (2 inches) in diameter and 12-cm (4.7-inches) long and capable of performing up to 1000 Hz without nonlinearities.

Introduction

This paper is a result of a contract to develop a passive isolation system using D-struts® for a high altitude application to isolate an optical payload from aircraft-borne jitter and environmental influences such as temperature, pressure, vibration, and shock loads. The design challenge consisted in meeting a 13-Hz isolation system 1st mode requirement within a limited volume with no permissible non-linearities in the operating range of 0-1000 Hz while experiencing large vibration, shock and static loads. This precluded the use of soft stops and led to a design optimized to minimize length and diameter as well as a strut soft enough to stroke the required amount. This resulted in D-struts® with stroke per unit length and component rotations outside Honeywell's design heritage. It was found that such a soft spring in such a small package resulted in a surge mode, surge mode harmonics and lateral modes at frequencies lower and gains higher than typical designs. This was detrimental to performance out to 1000 Hz and meant a change in modeling approach was required and a low outgassing viscoelastic coating was applied to the main spring to meet the customer specification.

D-Strut® Background

D-strut® isolation systems have been used consistently in space for the last 25 years for many applications, including satellite launch, momentum control, and payload isolation. They are passive mechanical devices made up of a linear-action machined spring and a fluid damper subassembly including hermetically sealed welded metal bellows. Figure 1 shows the 'MTV' strut with its main components labeled. They are 3 parameter isolators, with a spring in parallel with a series combination of a spring and damper, with 40 dB/decade roll-offs as compared to 20 dB/decade roll-offs from the more traditional two parameter isolators (a spring and damper in parallel). When D-struts® are positioned in a hexapod or octopod configuration they provide six degree of freedom support allowing decoupling between the payload and the supporting structure making them ideal for isolation.

* Honeywell Aerospace, Defense and Space, Glendale, AZ

The Design Challenge

The 'MTV¹' D-strut® is designed to withstand 623 N (140 lbf) axial load, rotate 7° at the main spring and flexure and stroke 0.99 cm (0.389 inch) in compression and 0.68 cm (0.267 inch) in tension, 0.057-0.083 stroke per unit length. More typical designs rotate 3° and stroke 0.025 stroke per unit length. To put this into perspective, the MTV D-strut® is 11.9 cm (4.7 inch) in length with a 5.08 cm (2 inch) diameter and weighs 860 g (1.9 lbm). More typical D-struts® would be 25.4 cm (10 inches) in length with a diameter greater than 7.62 cm (3 inches) and weigh significantly more than 910 g (2 lbm). It was found that such a soft spring in such a small package resulted in a surge mode, surge mode harmonics and lateral modes at frequencies lower and gains higher than desired. This was detrimental to performance out to 1000Hz. Figure 2 shows the actual performance of the hardware prior to applying a low outgassing viscoelastic material ((self-fusing tape (SFT)) and after the application of SFT. With SFT, the strut performance met customer specifications.

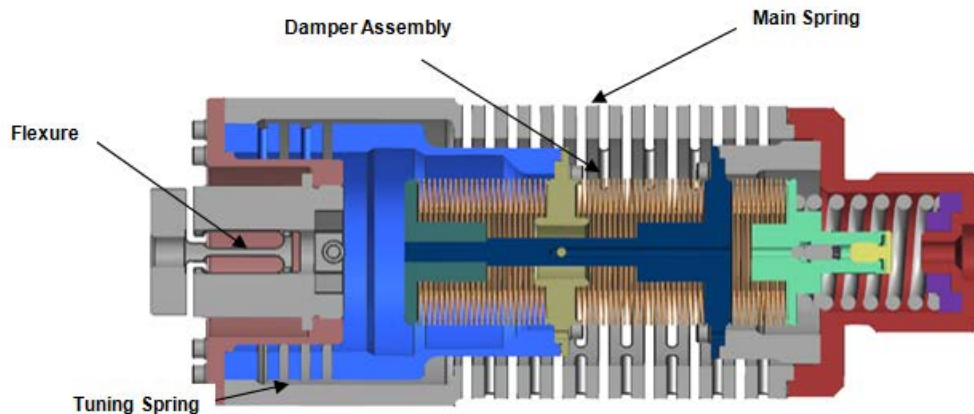

Figure 1. MTV Isolator Cross Section

Application and Test of a Viscoelastic Coating

Solution development

A machine spring coated with SFT was used to successfully attenuate undesired modes to acceptable levels of gain and meet performance requirements, as shown in Figure 2. Alternative solutions include the use of a tuned mass damper but this was not viable due to volume constraints and the presence of more than one mode with different excitation directions and frequencies. A complete redesign was out of scope and a coating of some sort was the only way to meet cost and schedule constraints. Several materials were tried and tested: SFT, heat shrink, Sorborthane, RTV Silicone embedded between the strut blades, constrained layer damping, neoprene sleeve, and a silicone coating. It was paramount that any solution applied was able to meet performance and stringent outgassing (max volatile condensable material content of 0.1% and a total mass loss of less than 1.0% by weight) criteria but should require no design modification, not create any particulate, and meet the life requirements of the design. Initial testing showed SFT to be the most promising. ASTM E 595 testing for outgassing was carried out at another Honeywell location (Clearwater) and allowed us to test multiple coatings and iterate on bakeout temperatures and durations in a relatively short time. With bake out, the self-fusing tape met all the requirements and a method to apply the SFT onto the struts consistently and repeatedly was devised.

Application of SFT

The material came in 2.5-cm (1-inch) wide tape with backing. A lathe was used to apply the tape onto the main spring with consistent tension, as the tension affected stiffness, and even overlap. Through trial and error the optimum lathe speed and feed rates, drag torque for the tape dispenser, and application angle

¹ Honeywell Program Name for this effort

were established. The setup is shown in Figure 3. After the application of the SFT, the units were tested for impedance, to confirm the required stiffness was met. The units were then baked for 40 hours, at 1013.26 Pa (1e-5 Torr) at 204°C (400°F) and impedance testing was repeated. Impedance testing confirms the static stiffness K_a , measures dynamic stiffness $K_a + K_b^2$, and allows the damping magnitude and peak damping frequency to be measured from which the damping coefficient C_a is determined. Instrumentation measures non-contact displacement at the shaker head vibration input end of the strut and load cell force at the fixed output end of the strut. Based on a sample of 4 struts wrapped in SFT, it was found that the standard deviation of the stiffness (K_a), stiffness (K_b) and damping coefficient (C_a) was 0.62%, 4% and 1.1% of the measured mean respectively and after bakeout these values changed 2.1%, 4.7% and 5% respectively. These values are within the deviation accounted for in Honeywell's systems analysis for K_a , K_b , C_a .

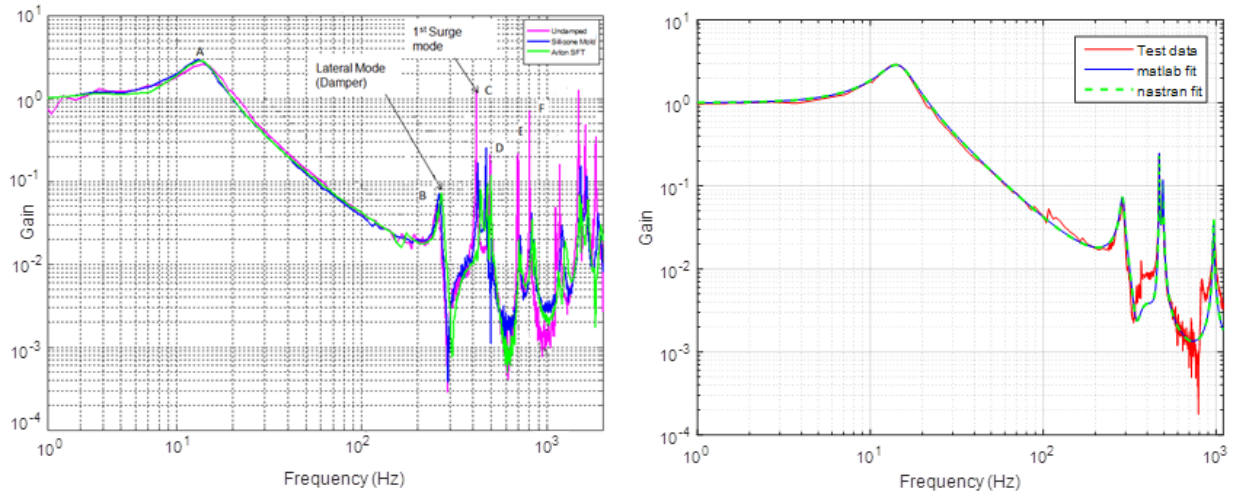

Figure 2. Left: Actual Transmissibility of Hardware (prior to coating in magenta, with a silicone mold coating in blue and with SFT coating in green). A: Resonant Frequency, B: First lateral mode, C: First Surge Mode, D: Second Lateral mode, E: Third Lateral Mode, F: Harmonic Surge Mode. Right: Bipod Transmissibility Performance of Strut with SFT coating and Model Correlation.



Figure 3. Left: Tap Test Set up. Right: SFT wrap set up.

² Where K_b is the in-series spring with the damper

Testing over temperature

SFT has an operational temperature of -51°C to 180°C . This was well within the temperature requirements, however, thermal cycle testing was carried out to ensure temperature did not affect the material robustness, in terms of life and performance. The MTV isolators were subjected to two survival temperature cycles of -40°C (cold) to 71°C (hot) and eight non-operational temperature cycles of -24°C (cold) to 50°C (hot) at cycle rate of $3^{\circ}\text{C}/\text{minute}$; both tests carried out at ambient pressure. The strut was subsequently tested in the bipod transmissibility configuration and it was ascertained that the strut did not show any signs of damage and that performance did not deteriorate. Thermal impedance testing was carried out to evaluate the performance of the SFT during the operational temperature range. Figure 5 shows the results of the test. The temperature shift causes the Ca to decrease and increase as the temperature rises and falls, shifting the Phase Shift peak, left and right. The attenuation of the isolator modes exhibits very little change. The frequency shifts are as expected with viscoelastic behavior: getting stiffer with lower temperature and getting softer with higher temperature. The frequency shift is less than 5%, which is within the variation kept during analysis of the machined parts. This was considered acceptable.

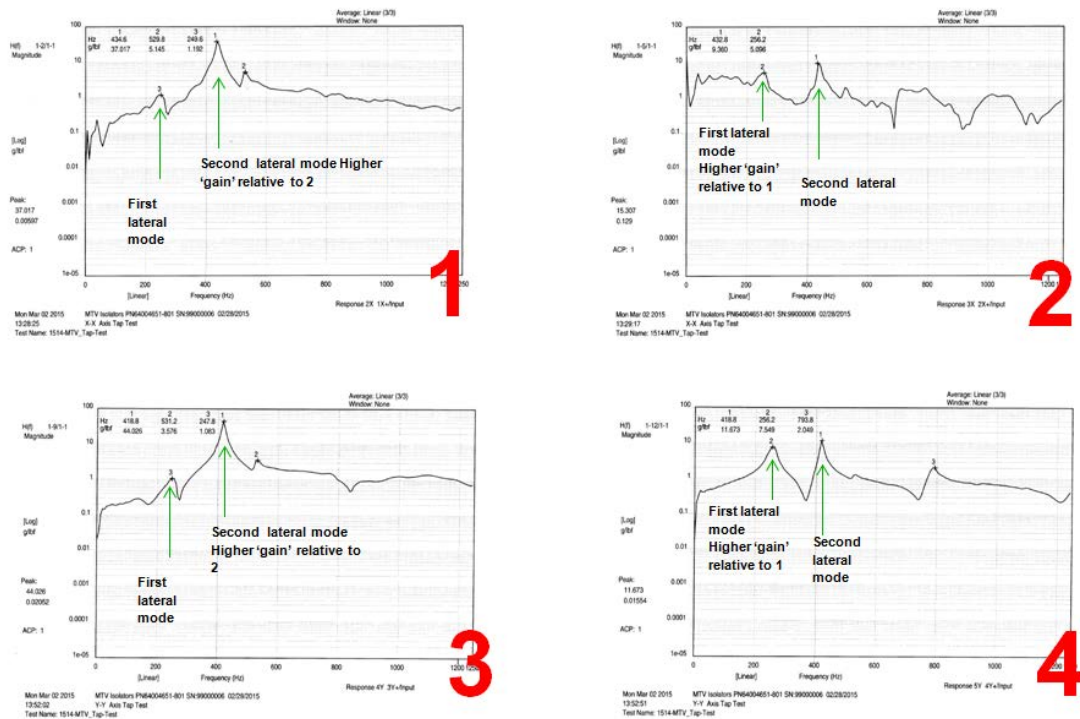

Figure 4. Top: X-X excitation; X axis results. Bottom: Y-Y excitation; Y axis results

Testing for linearity with forcing and for robustness

High-level and low-level bipod transmissibility testing was also carried out, forcing at random non-op levels and random-op levels. It was found that performance was consistent, such that it was not necessary to consider non-linearities in the range of interest. Life testing included 12 full quasi-static cycles and the full (100-hour) requirement for random non-op and thermal cycle testing. Bipod transmissibility before and the life test was carried to check for any difference in performance. No changes were found and therefore we were confident that SFT was robust to withstand specification environments. The units were subjected to qualification testing. This included single strut & bipod proof load, random survival levels, shock levels and thermal cycle testing. Before and after data from the life test and qualification testing shows that the material had not degraded.

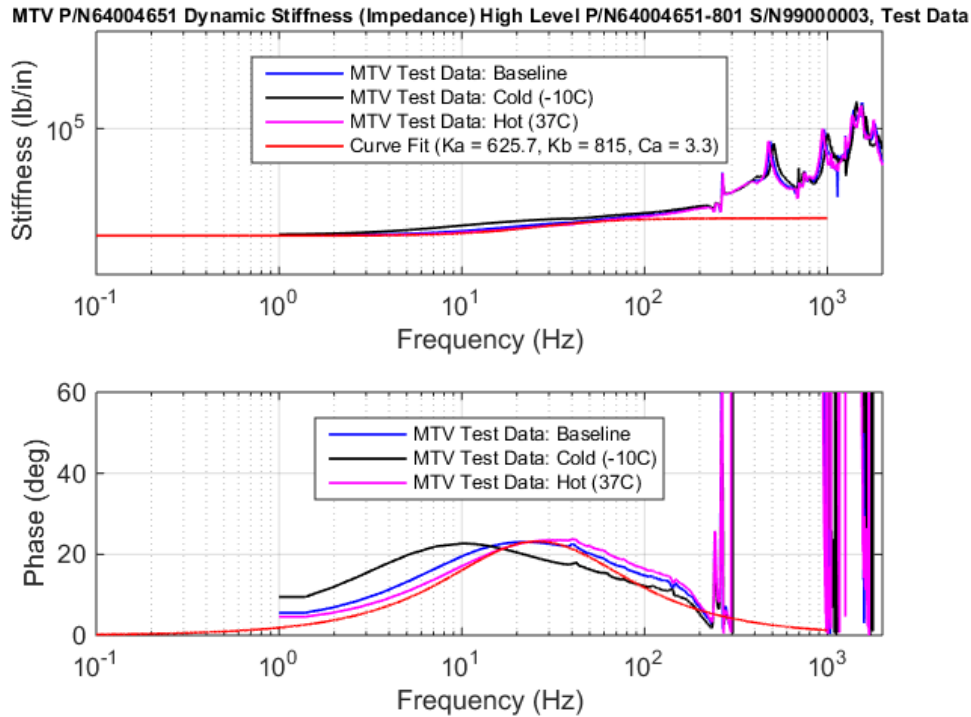

Figure 5. Thermal Impedance Results.

D-Strut Model Development and Model Correlation

Typical applications have operational requirements out to a couple hundred hertz (300 Hz typical) and historically our ability to predict surge modes allows us to design them to be outside the requirement frequency range. In this case, the presence of surge mode harmonics and high gain lateral modes meant the standard approach was not sufficient and more involved testing and modeling correlation was required. Tap testing was carried out on the strut and it was found that the presence of a nested flexure and a male threaded interface meant the lateral modes were sensitive to flexure orientation. The tap test consists of shaking the strut laterally (X & Y direction in Figure 3) with both ends of the struts held and several accelerometers placed on the isolator. Two rows of accelerometers were used, placed at 90 degrees from one another. This allows for lateral modes in the strut to be identified, including differences in modes in X and Y. Figure 4 shows the presence of two lateral modes, with the first lateral mode, associated with the main spring having higher gain closest to the spring (accelerometers 2&4), and the second lateral mode, associated with the flexure having higher gain closest to the flexure (accelerometers 1&3). The frequency³ of the first lateral mode does not change with excitation direction and is 256.2 Hz for accelerometers locations 2 and 4 (closest to the main spring) whereas the frequency of the second lateral mode is sensitive to excitation direction and change from 434.6 to 418.8 Hz for X-X and Y-Y excitation respectively for accelerometer locations 1 and 3 (closest to the flexure). These results showed that flexure orientation had an effect of lateral mode placement. Subsequent bipod testing showed that the gain of the second lateral mode was dependent on flexure orientation; when flexures were orientated in the same direction the modes constructively interfered producing maximum gain. Based on tap testing and bipod transmissibility data for different flexure orientations, a detailed Simulink model was created and tuned to test data; a good agreement between test data and model data is shown in Figure 2. As mentioned above, it was important to characterize the material used, however, no attempt was made to create a non-linear model of the viscoelastic material as the change in characteristics was within the

³ N.B. the frequencies reported are lower than those found in transmissibility testing due to the mass of accelerometers. This testing was conducted for mode identification purposes.

predicted performance envelope tolerance due to machine part tolerance and bellows stiffness tolerance. The model, shown in Figure 6, shows the inclusion of a detailed surge model, which is represented by 12 masses simulating the sprung masses of the main spring and damping to control the gains of these modes.

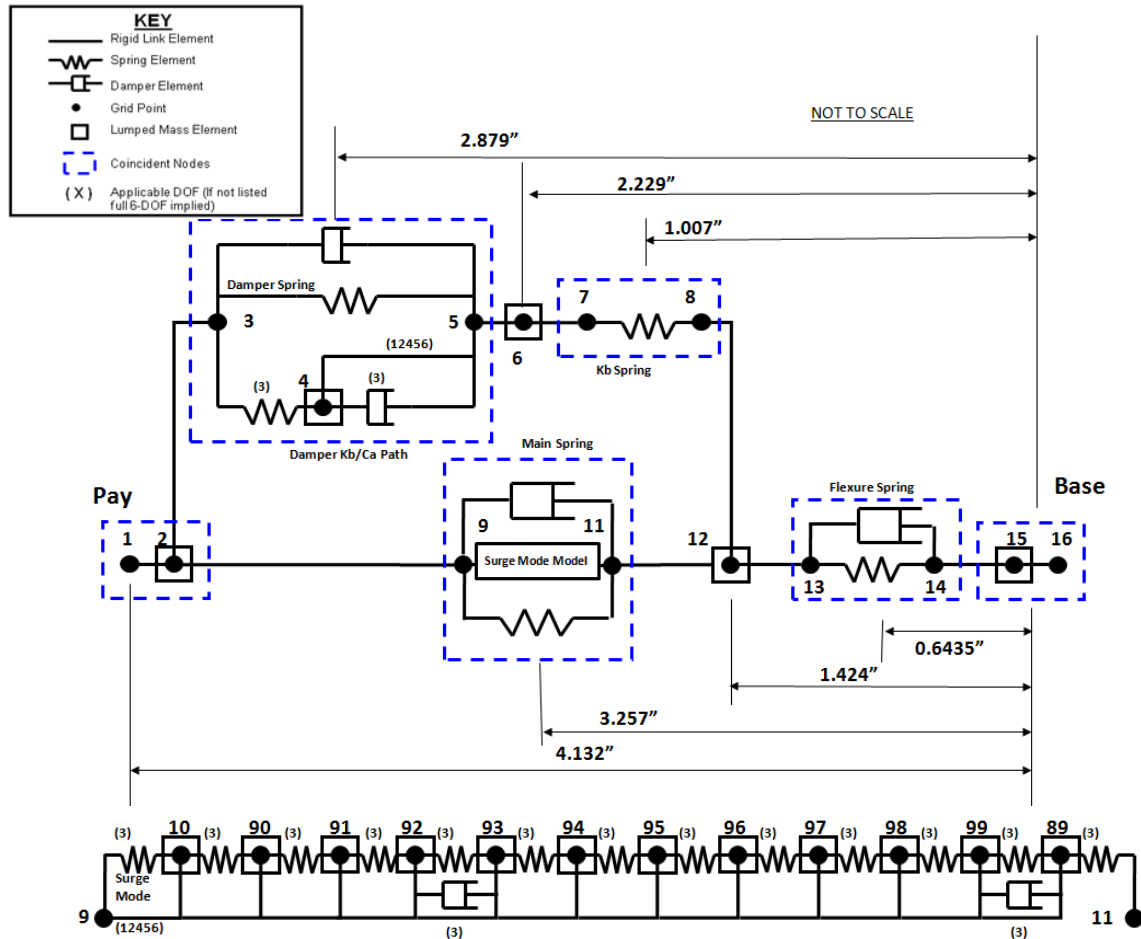

Figure 6. Nastran and MATLAB/Simulink Bipod model

Conclusions

This paper presents an isolation system comprising of D-Struts®, designed to meet limited volume constraints with a 13-Hz 1st mode requirement with no permissible non-linearities in the operating range of 0-1000Hz, and experiencing large vibration, shock and static loads. It was found that resulting design was susceptible to surge and lateral modes as well as flexure orientation. This required a more detailed approach to strut mode identification and strut model development. A detailed Simulink model was created and tuned to test data providing good agreement between the test data and model data is shown. The model shows the inclusion of the surge model, which is simulated by 12 masses representing the sprung masses of the main spring and damping to control the gains of these modes. A machine spring coated with self-fusing tape, a viscoelastic material, was used to successfully attenuate undesired modes to acceptable levels of gain and meet performance and life requirements. A big concern with viscoelastic materials is their ability to meet life requirements and work repeatedly and predictably. In this paper we detail the tests carried out to ensure robustness and strut performance repeatability was met. The presence of such a solution allows lighter and smaller struts to attenuate to high frequencies, such that challenging program requirements such as the one herein described (13-Hz 1st mode without stops, and high associated loads) can be met.