

Thermal Vacuum Testing of a Helium Loop Heat Pipe for Large Area Cryocooling

Jentung Ku

Franklin Robinson

NASA/Goddard Space Flight Center

Greenbelt, Maryland, USA

46th International Conference on Environmental Systems

Vienna, Austria

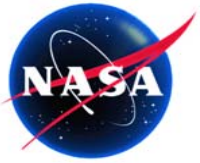

Outline

- **Introduction/Background**
- **CLHP Design and Operating Principle**
- **Test Article**
- **Test Setup**
- **Test Results**
- **Conclusions**

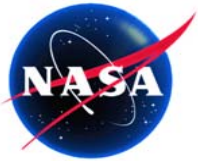

Introduction/Background

- **Future NASA space telescopes and exploration missions require cryocooling of large areas such as optics, detector arrays, and cryogenic propellant tanks.**
- **One device that can potentially be used to provide closed-loop cryocooling is the cryogenic loop heat pipe (CLHP).**
- **A CLHP has some inherent advantages.**
 - **Long life time because of no liquid boil-off in a closed loop**
 - **Isolating optics and detectors from the mechanical vibration of the cryopump**
 - **Accommodating various geometries of the heat source**
- **Under the NASA SBIR program, a helium CLHP was successfully developed in 2007 by TTH Research, Inc.**
 - **Demonstrated its feasibility for cryocooling over a large area**
 - **Limited testing due to cost and schedule constraints**

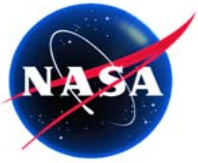

Testing of a Cryogenic Loop Heat Pipe for Large Area Cryocooling

- Through funding from NASA Engineering & Safety Center, GSFC has performed experimental testing of the CLHP delivered by TTH Research to demonstrate its feasibility as a closed-loop system to cool large areas such as optics, detector arrays, and cryogenic propellant tanks.
- The CLHP was reconfigure so that a cryocooler was used as the heat sink (instead of a helium dewar).
 - Test the CLHP in a thermal vacuum chamber.
 - Use helium as working fluid to demonstrate its operation in temperature ranges of 3.0K to 4.0K.
 - Characterize the CLHP performance under transient and steady state.

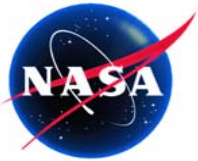

Traditional Loop Heat Pipe

- **Application**
 - Waste heat is acquired over a small area by the LHP capillary pump and transported to a large area (e.g. space radiator) for rejection.
- **No External Pumping Power**
 - Waste heat provides the driving force.
- **No Moving Parts**
- **Robust Operation**
 - Passive
 - Self-regulating
- **High Pumping Capability**
- **High Thermal Conductance**
- **Smooth-walled and flexible transport lines provide flexibilities for design, integration and testing.**

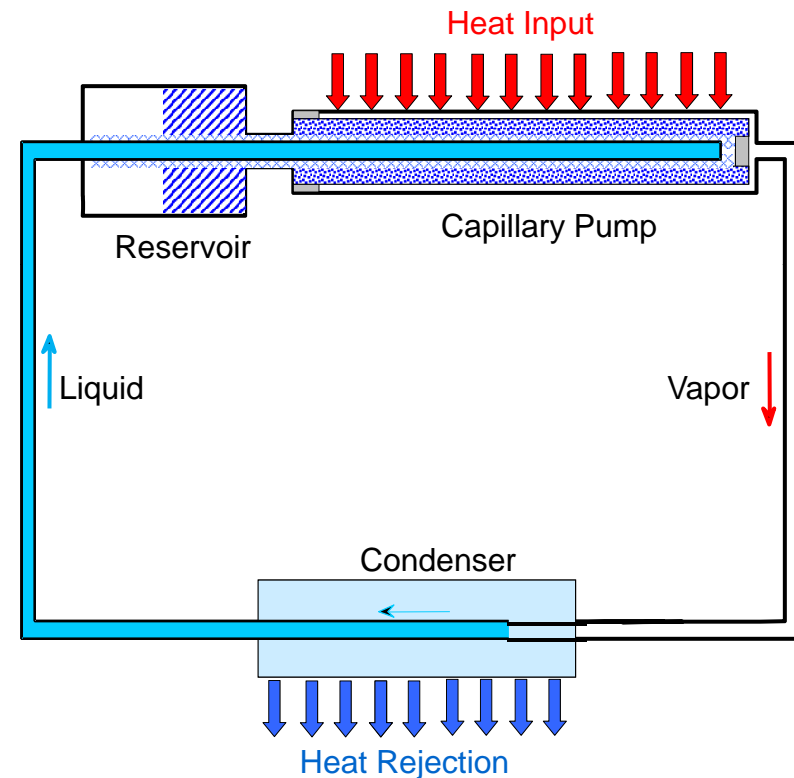

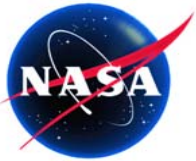

CLHP for Large Area Cooling Applications

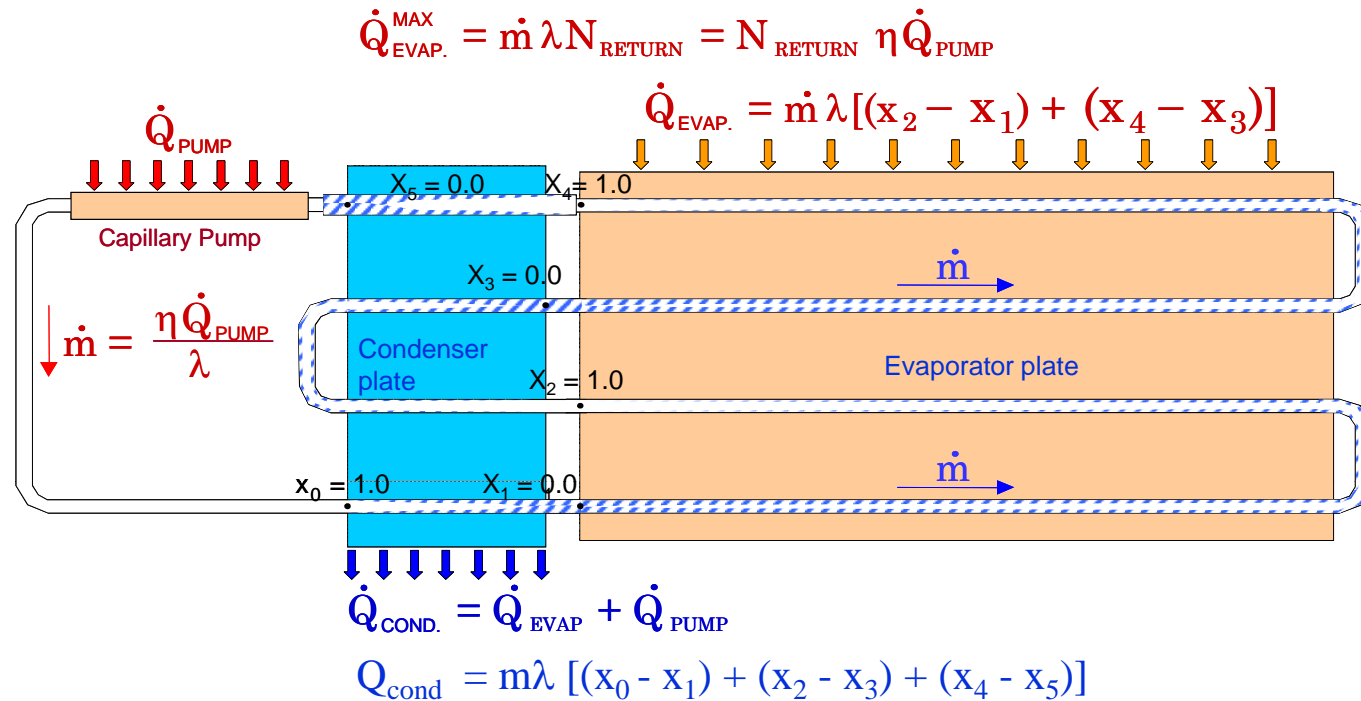

- Heat is absorbed over a large area and rejected into a small area.
- An external power is applied to the capillary pump to provide the driving force for fluid circulation.
- The CLHP transport line flows alternately between a condenser plate attached to a cryocooler and an evaporator plate attached to the heat source.
- Vapor condenses into liquid as it passes through the condenser plate, and liquid vaporizes as it passes through the heat source.

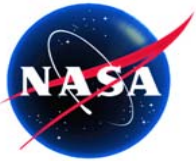

CLHP for Large Area Cooling Applications

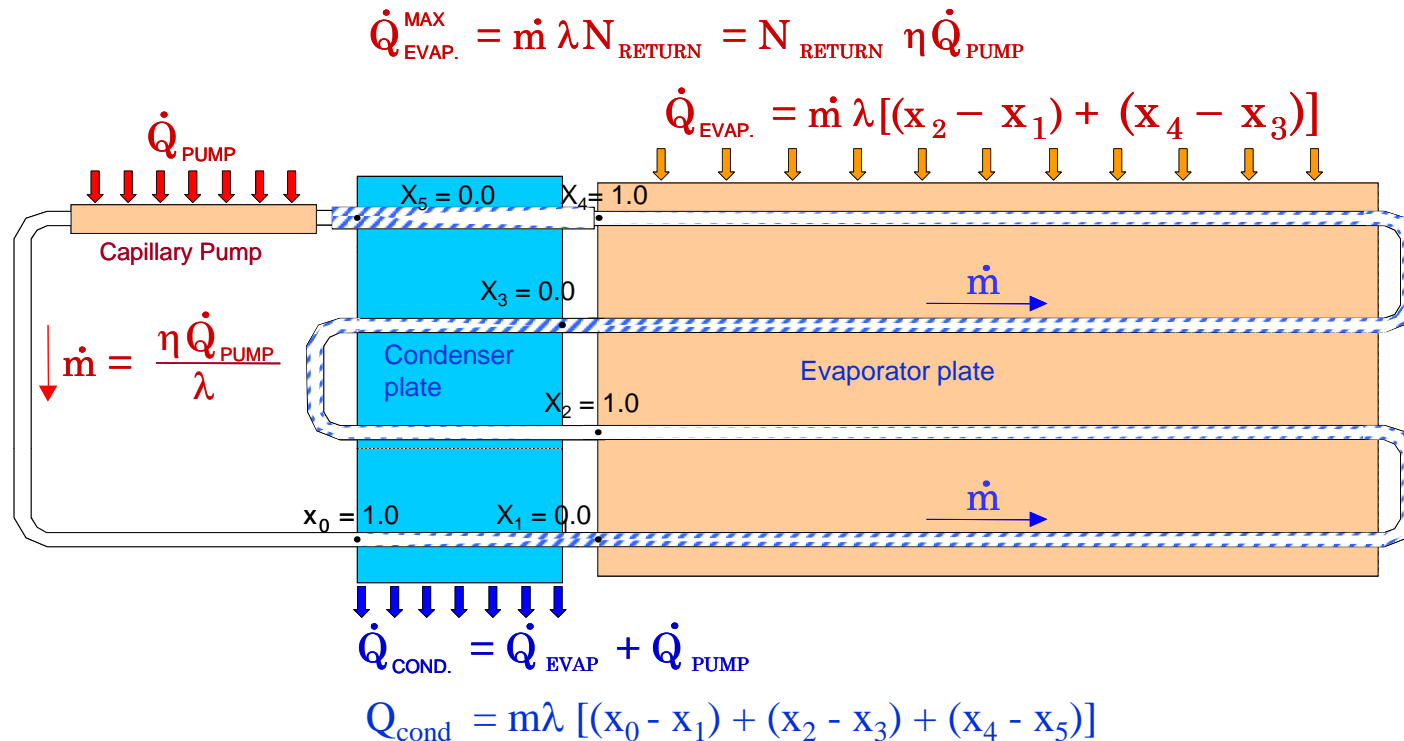

- The amount of heat that can be acquired is a function of the heat applied to the CLHP capillary pump and the number of passes that the fluid flows through the heat source and the condenser plate.
- The maximum amount of heat that can be applied to the capillary pump is limited by the heat transport capability of the CLHP.

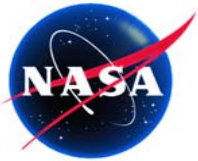

Technical Challenges of CLHP

- **A mismatch of coefficient of thermal expansion between the capillary pump and the primary wick**
 - **Solved by using the same material for capillary pump and primary wick**
- **Containment of the system pressure at ambient temperature**
 - **Solved by using a hot reservoir attached to the CLHP to reduce the system pressure**
- **Start-up from an initially supercritical state**
 - **Solved by using a hot reservoir attached to the CLHP to reduce the system pressure**
- **Parasitic heat gain at cryogenic temperatures**
 - **Minimized by proper insulation**

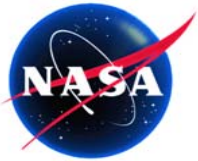

CLHP Test Article with Temperature Sensor Locations

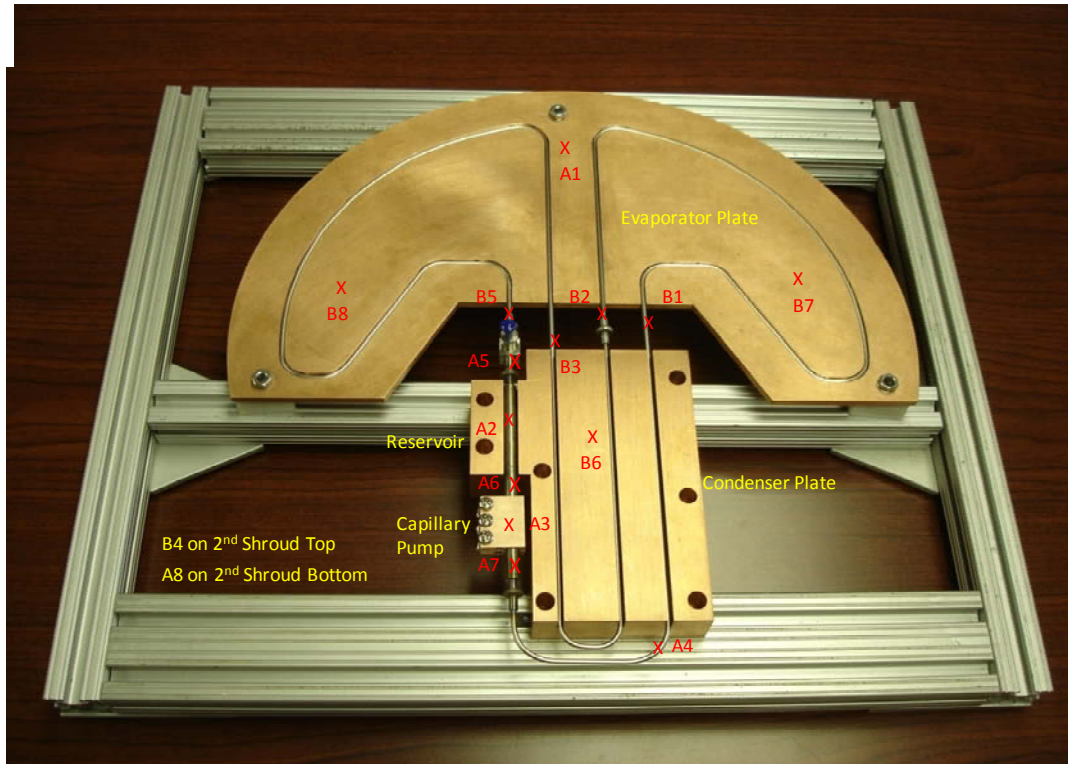

- Delivered by TTH Research in 2007
- Manufactured by ThermoCore, Inc.

- CLHP
 - all stainless steel construction
 - capillary pump: 1/4"OD x 1.5"L
 - wick: 1.2 μ m x 45% porosity
 - reservoir: 1/4"OD x 2.5"L
 - transport line: 3/32"OD x 63"L
- Evaporator Plate
 - Copper, 10" ϕ 48 in²
- Condenser Plate
 - Copper, 3" x 5.5" x 1"
- Hot reservoir
 - 1000 ml (not shown)

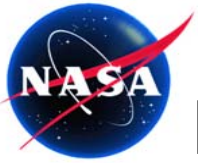

Dynavac TV Chamber with Shroud Extension



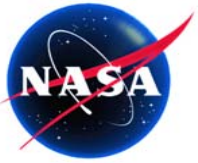

CLHP Inside Thermal Vacuum Chamber

- The CLHP was placed inside a secondary shroud which was surrounded by the primary shroud of the thermal vacuum chamber.

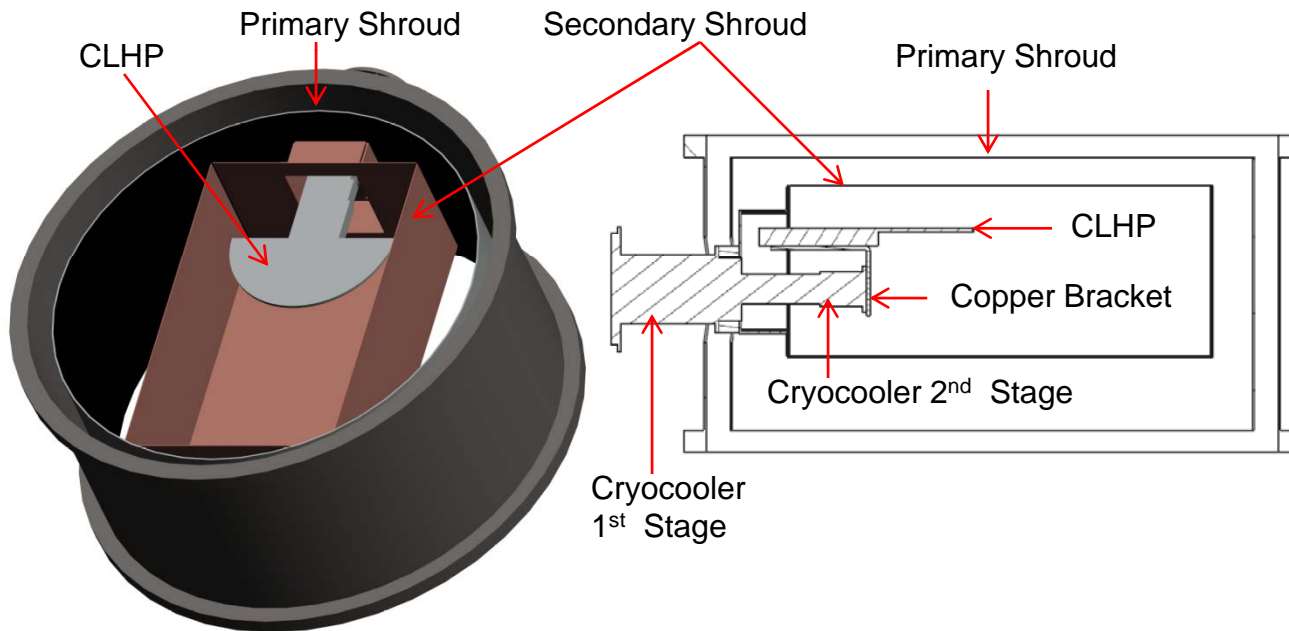

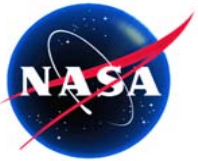

CLHP inside Thermal Vacuum Chamber

- 1: CLHP
- 2: Cryocooler mounting bracket
- 3: Secondary shroud
- 4: Primary shroud
- 5: Dynavac™ vacuum chamber

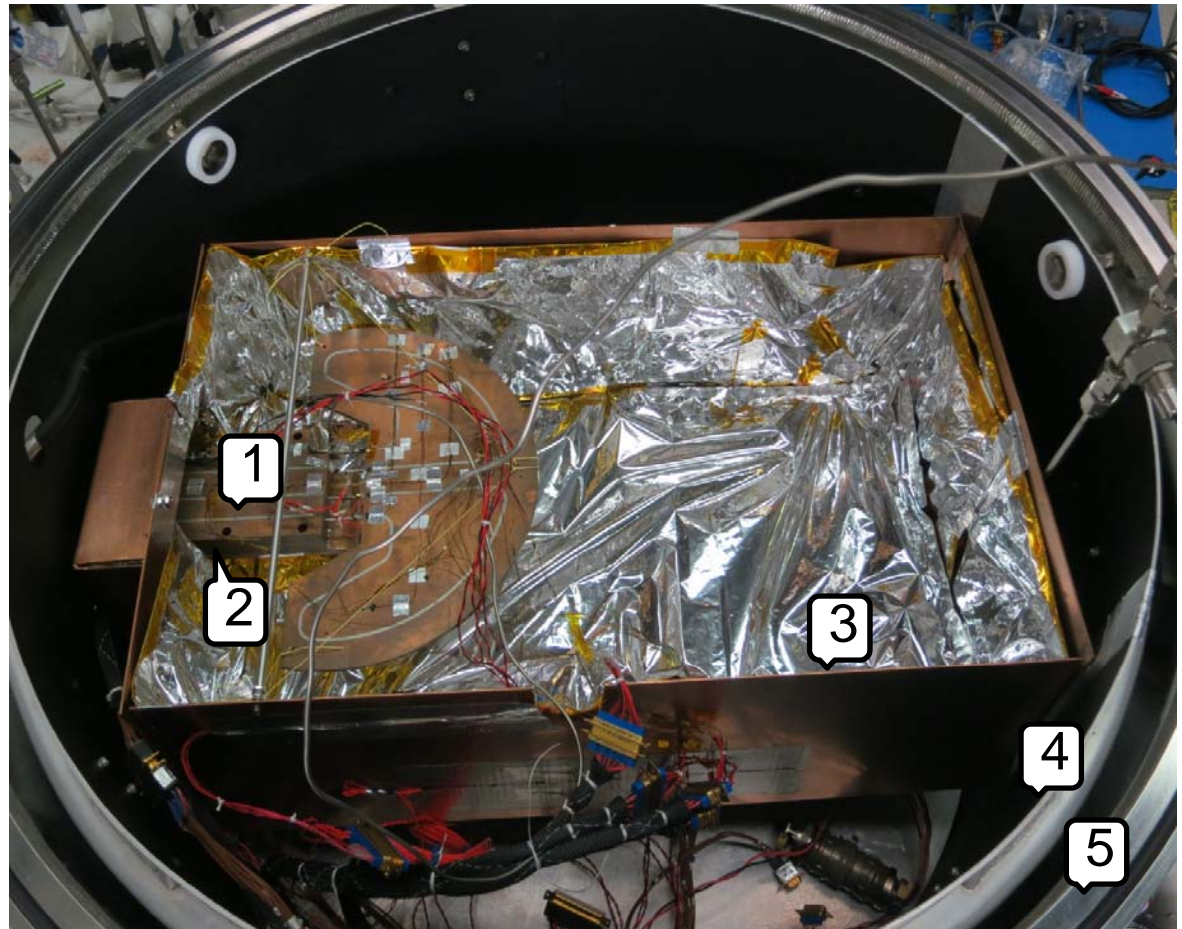

- The secondary shroud is cooled by the first stage of the cryocooler.
- The CLHP condenser plate is cooled by the second stage of the cryocooler.

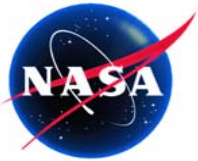

Tests Performed

- **Evaporator Cool Down from Ambient Temperature**
- **CLHP Startup**
- **Variable Heat Loads to Capillary Pump and Evaporator**
- **Power Cycle**
- **Pump Capillary Limit**
- **Steady State Long Duration Operation**
- **Evaporator Heat Removal Capability**

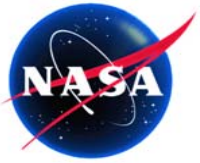

CLHP Test Article with Temperature Sensor Locations

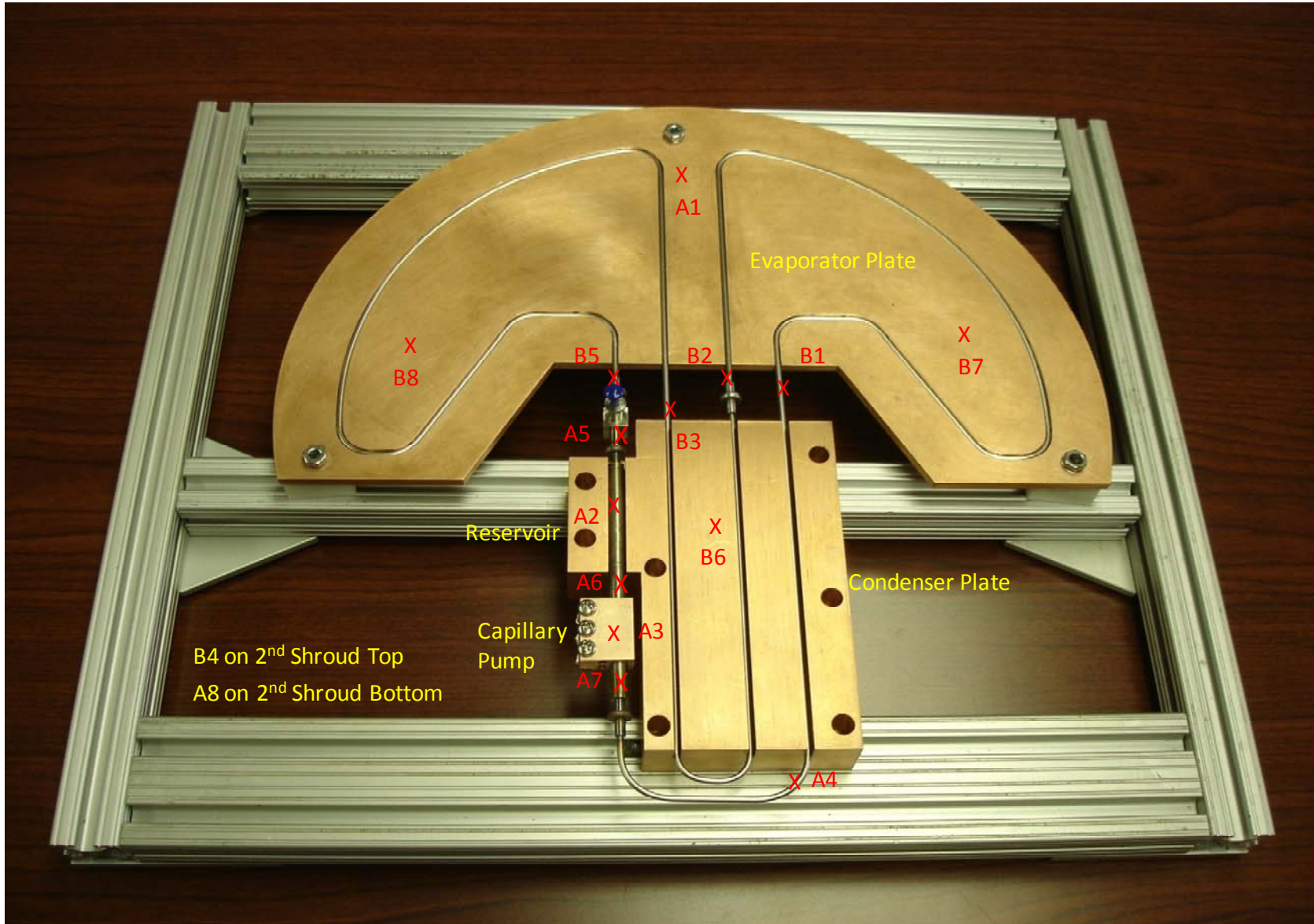

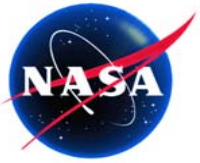

Helium - T_{sat} versus P_{sat}

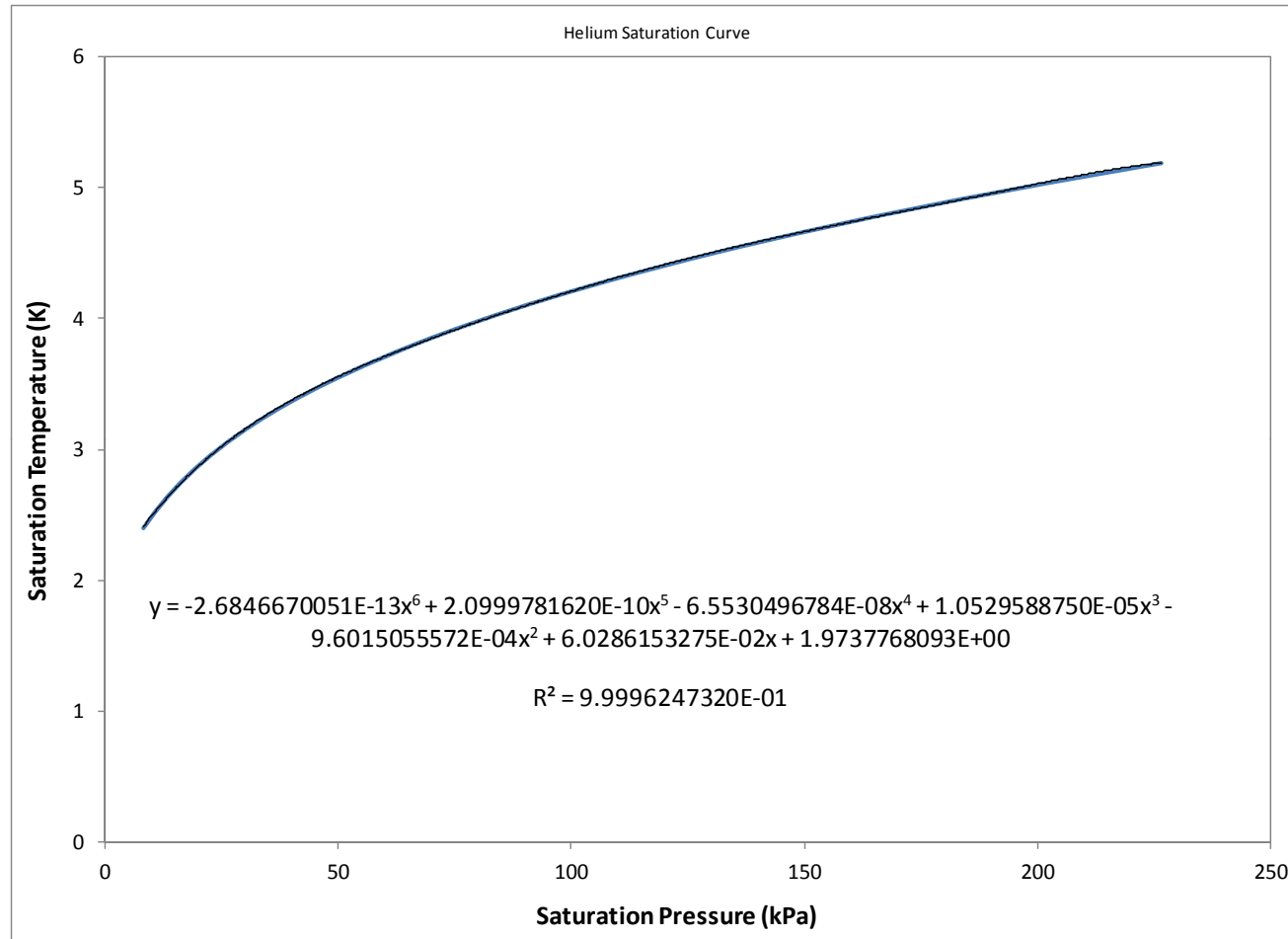

- **T_{sat}** derived from the measured **P_{sat}** provides a reference for the loop saturation temperature

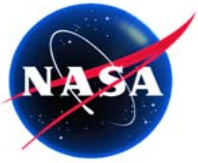

Thermal Conductivity and Specific Heat of OFHC Copper

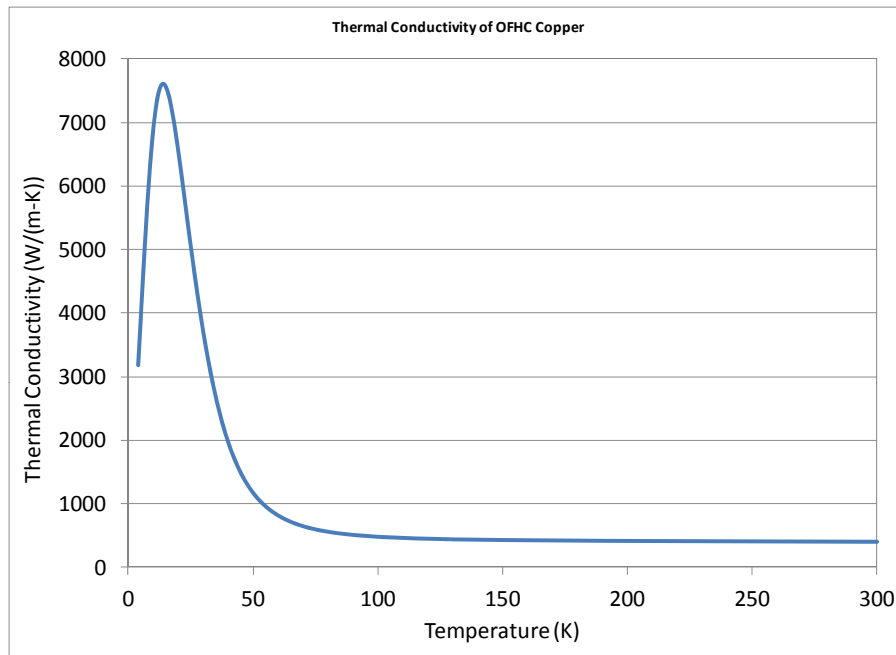

Thermal Conductivity

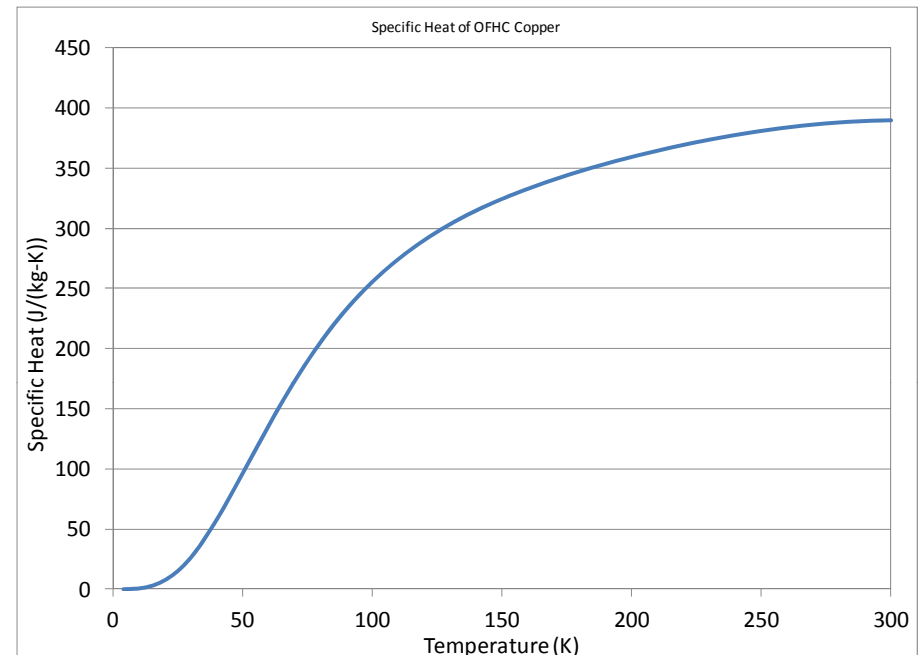

Specific Heat

- **The evaporator plate and condenser plate were made of copper, which has extremely high thermal conductivity and extremely low specific heat at low temperatures.**
- **All three temperature sensors on evaporator plate showed uniform temperatures.**

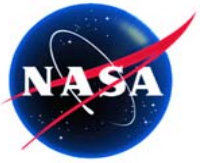

Thermal Conductivity of SS316

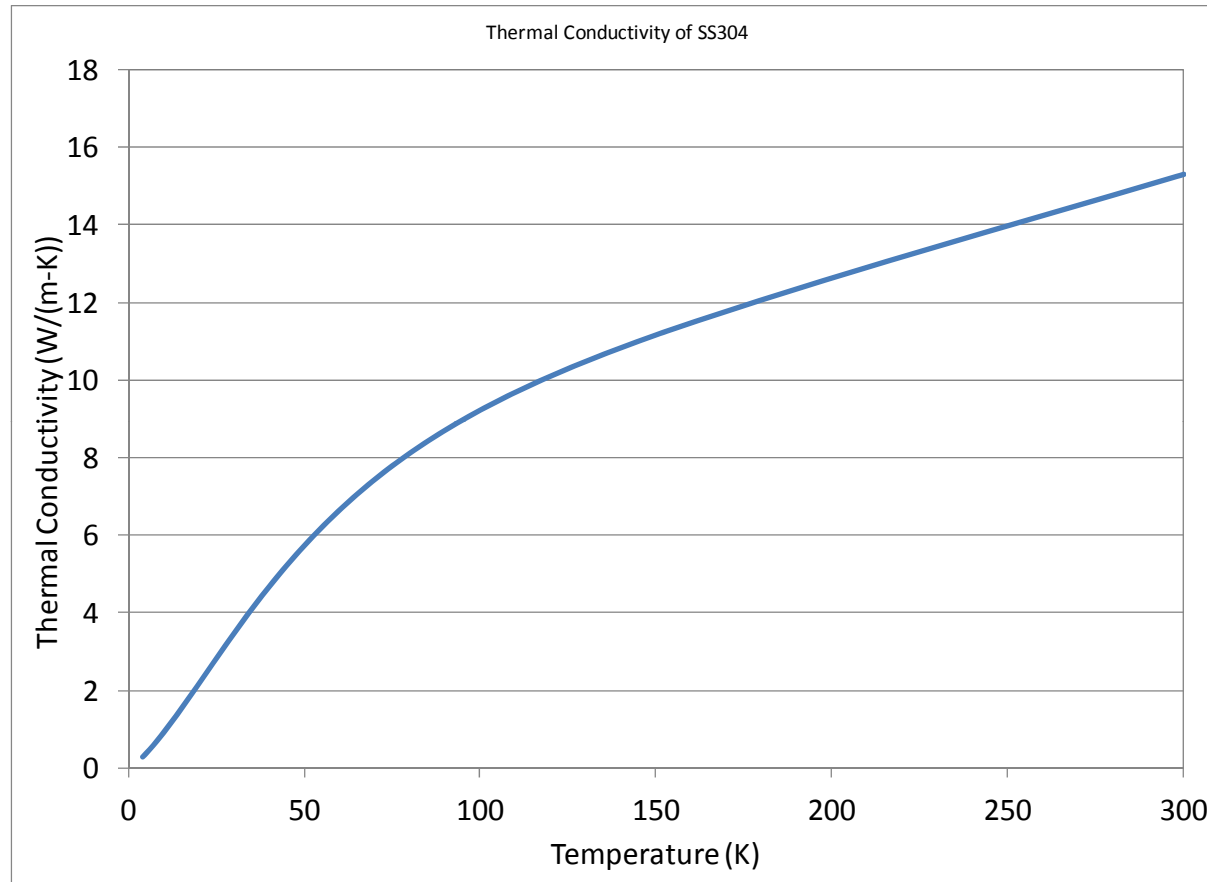

- **The low thermal conductivity of SS316 at low temperatures provides good insulation between the evaporator plate (heat source) and condenser plate (heat sink).**

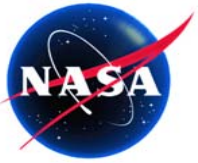

Initial Cool-down from 298K (1/2)

- The capillary pump, reservoir and condenser plate were cooled from 298K to 5K in 6 hours.
- The evaporator plate temperature dropped slowly, and took nearly 3 days to cool from 298K to 4K.

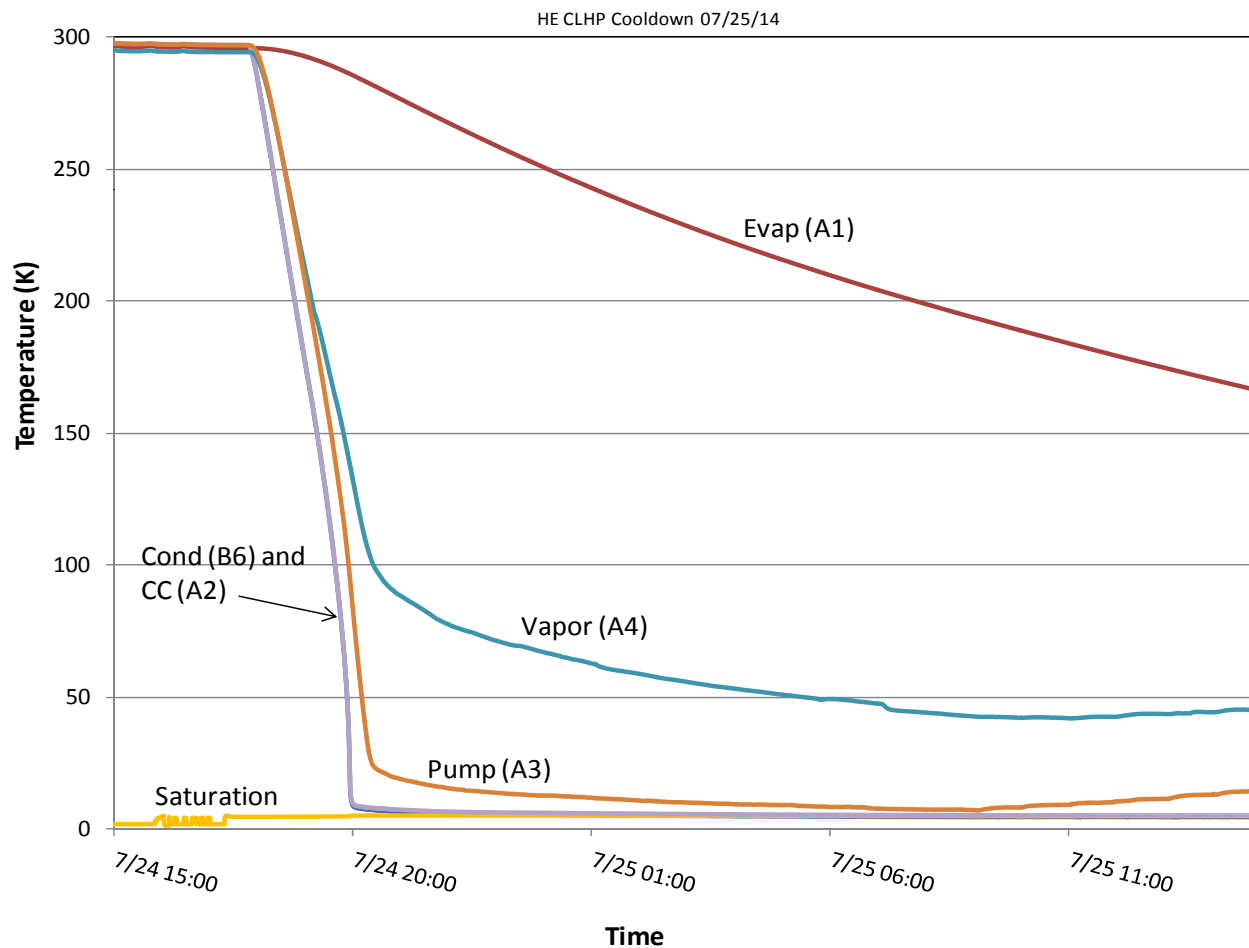

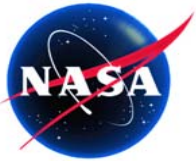

Initial Cool-down from 298K (2/2)

- When the evaporator plate temperature dropped below 50K, the rate of cool-down increased rapidly due to a decrease in the copper specific heat and an increase in its thermal conductivity.

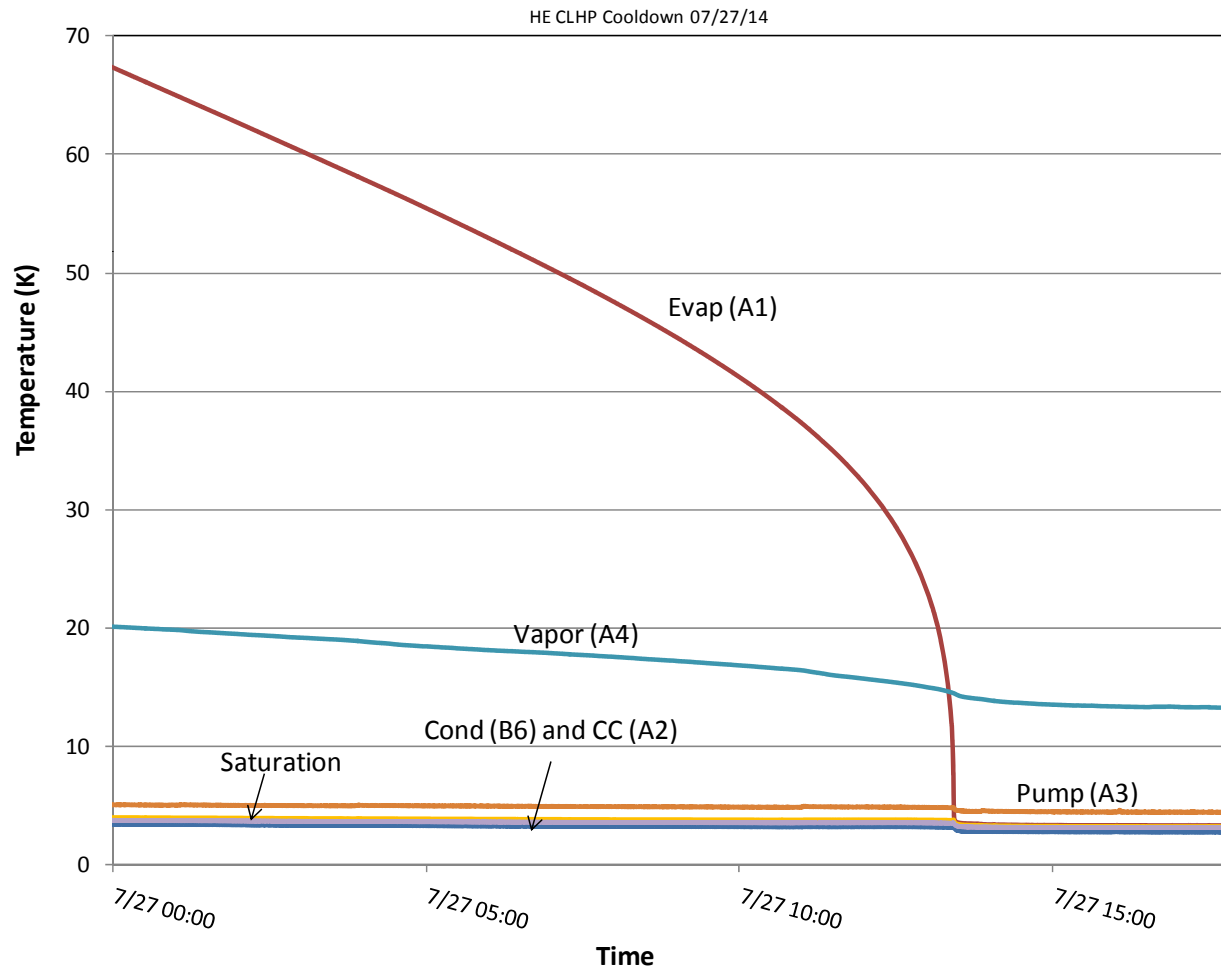

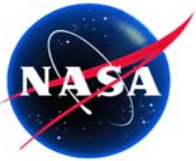

Startup (20mW/20mW)

- Loop started successfully with 20mW to pump and 20mW to evaporator.
- Condenser temperature increased due to heat load from pump and evaporator. This caused the saturation temperature to increase.
- The pump and evaporator temperature increase due to heat loads, and was further affected by the saturation temperature.

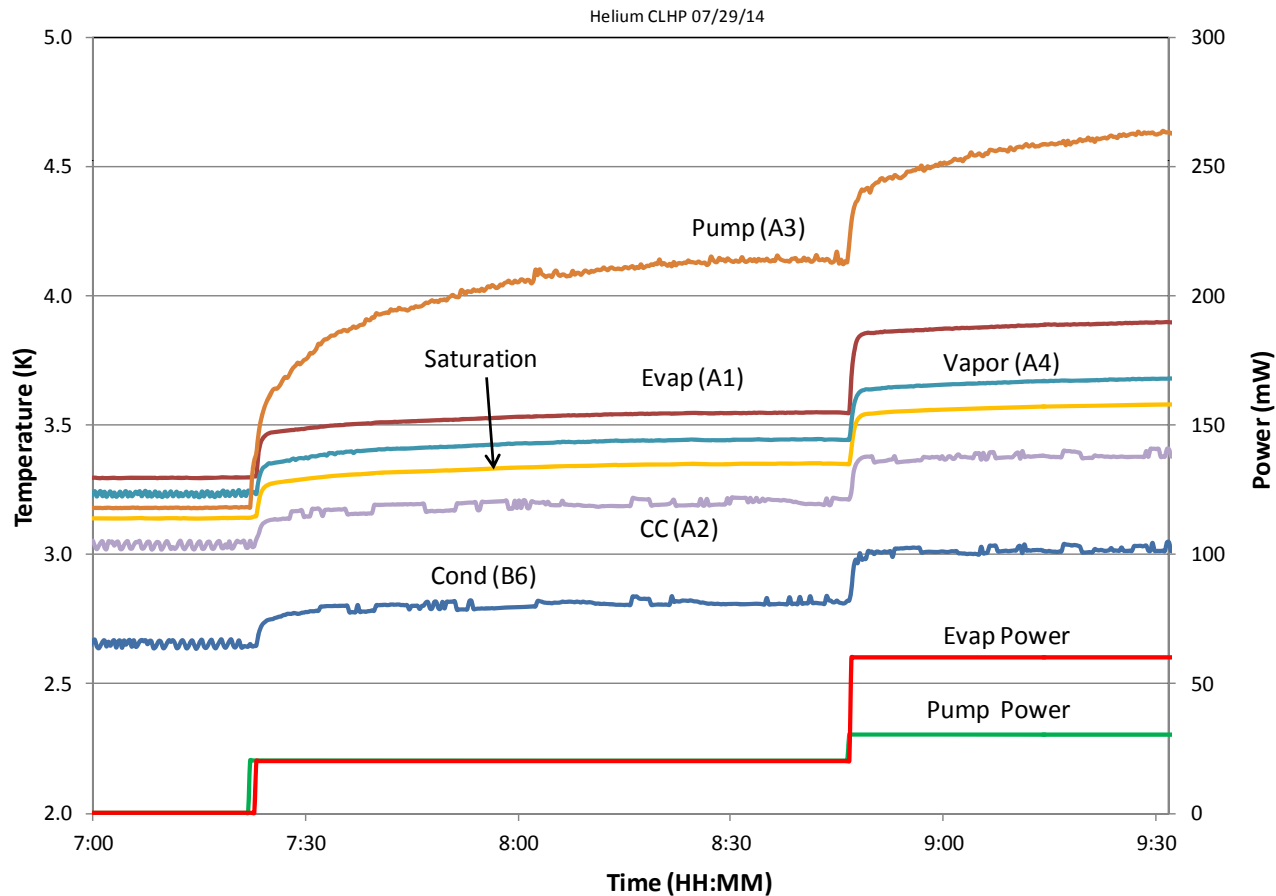

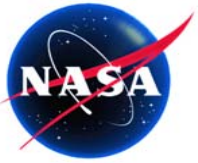

Startup (30mW/0mW and 30mW/30mW)

- Startup was not successful with 30mW to pump alone. There was insufficient liquid in the pump without any power to evaporator.
- Loop started as soon as 30mW was also applied to evaporator.

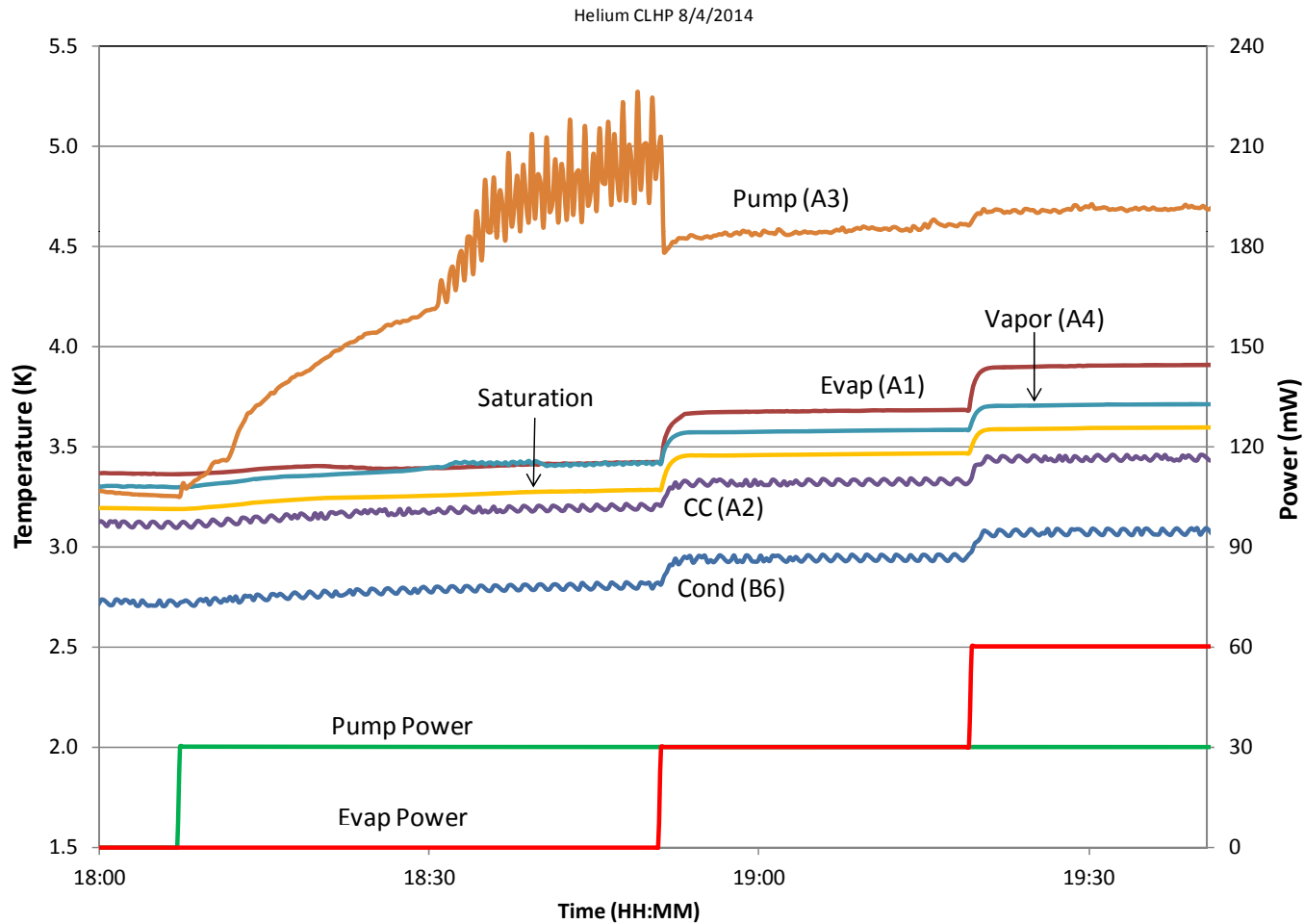

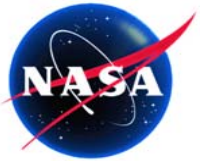

Startup (20mW/0mW)

- Loop started successfully with 20mW to pump alone. This was not expected.

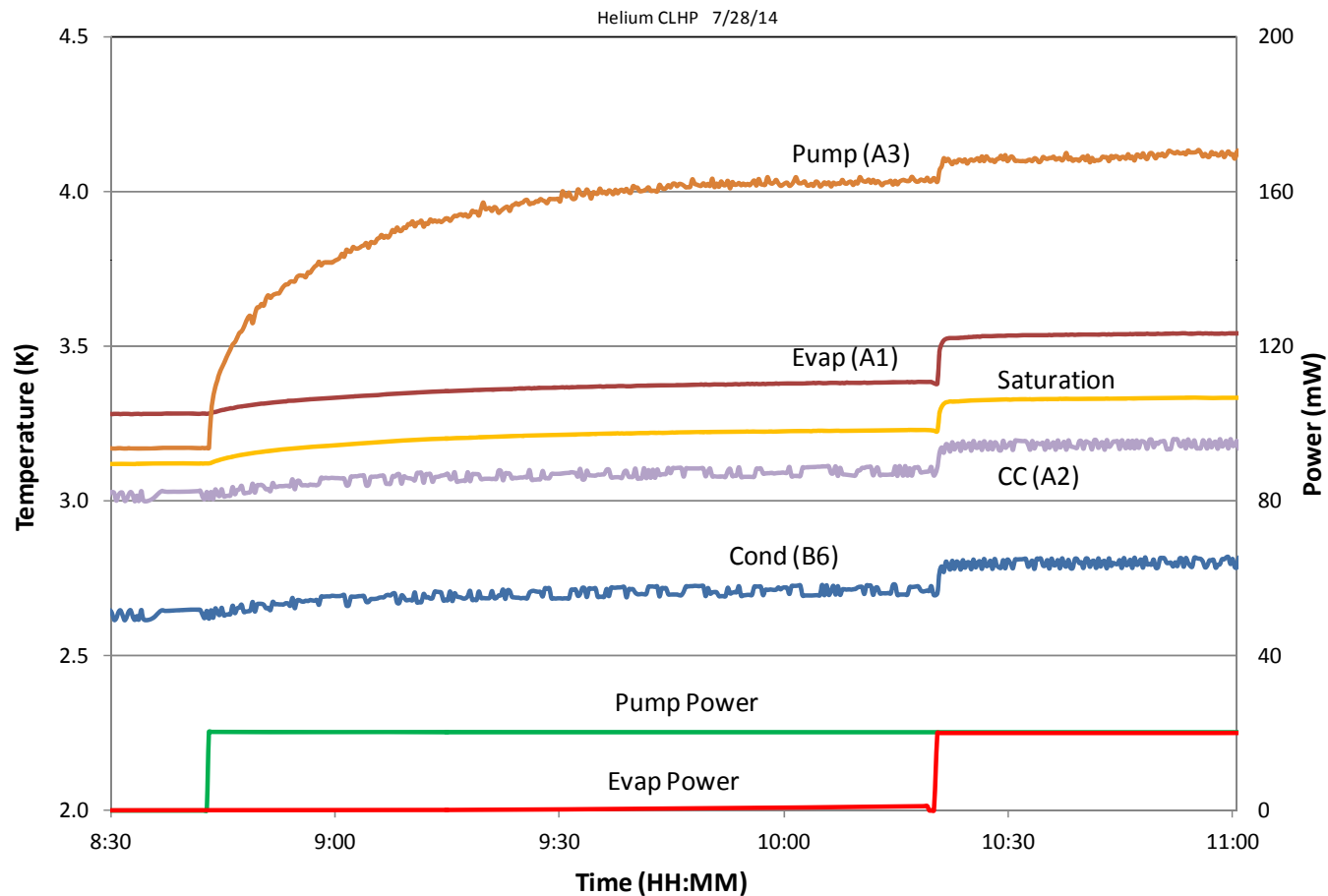

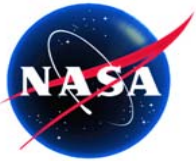

Power Ramp-up

- Loop started with 20mW to capillary pump alone.
- Pump power increased from 20mW to 60W and evaporator power increased from 20mW to 120mW (changed one power at a time).
- For a given pump power, the evaporator could remove twice as much power.

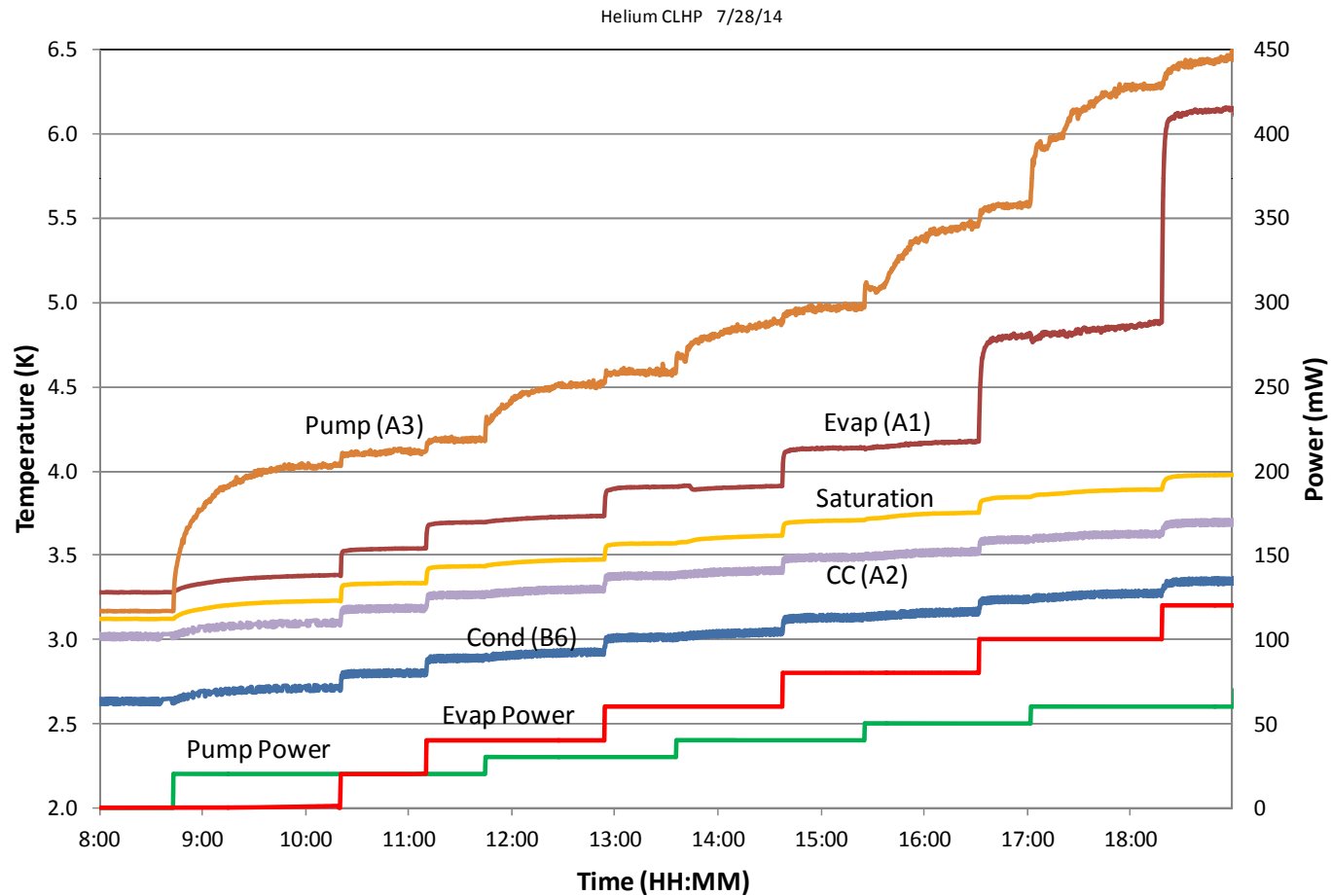

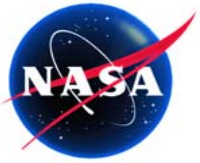

Power Ramp-up

- Demonstrated that the evaporator could remove twice as much power as the pump power for pump power between 30mW and 50mW.
- Both powers were changed simultaneously.

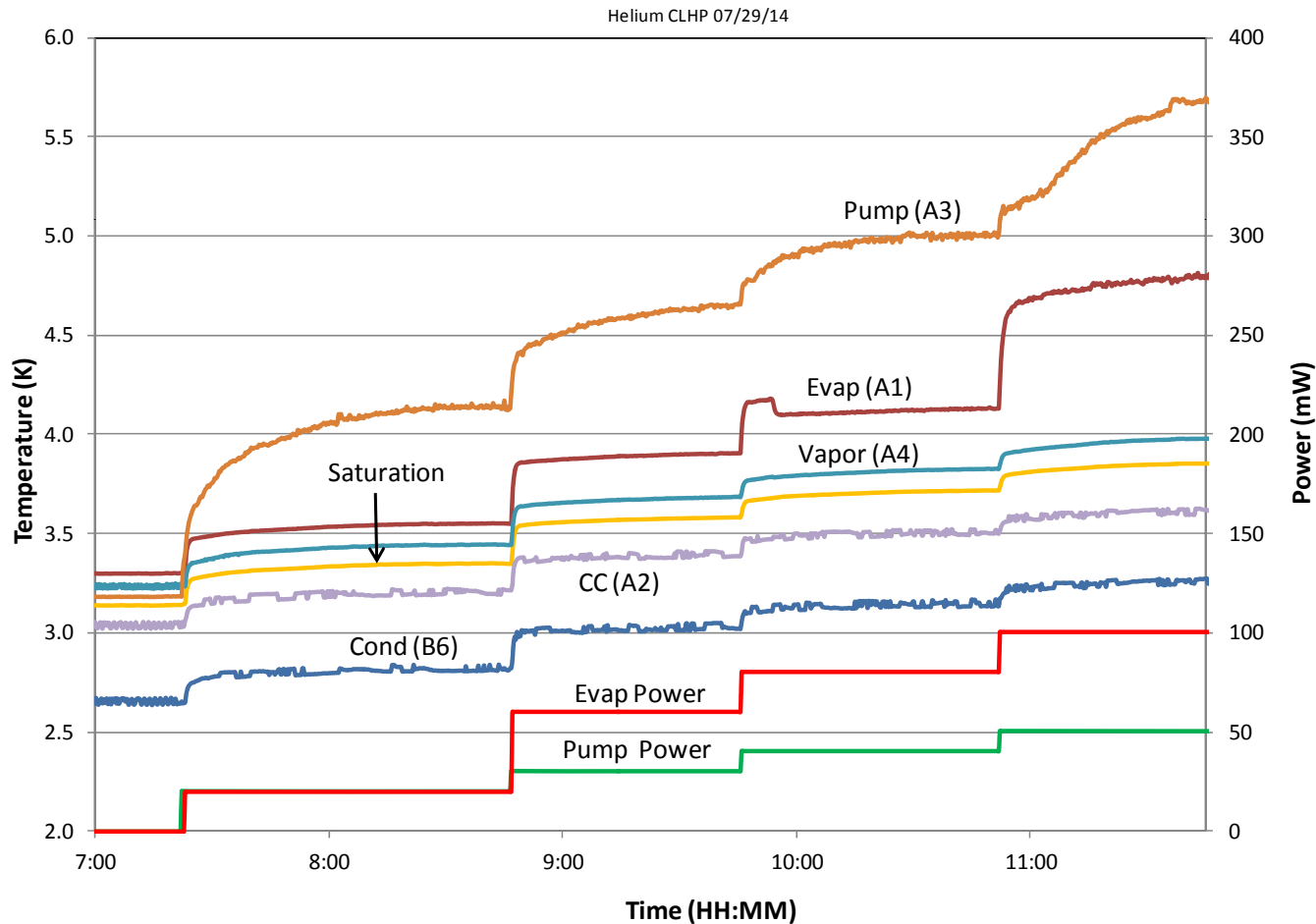

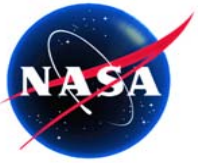

Evaporator Power Cycle

- Pump power was kept constant at 50mW.
- Evaporator power changed from 100mW to 20W to 100mW
- The loop could adapt to a rapid change in evaporator power. The evaporator temperature was the same before and after power change.

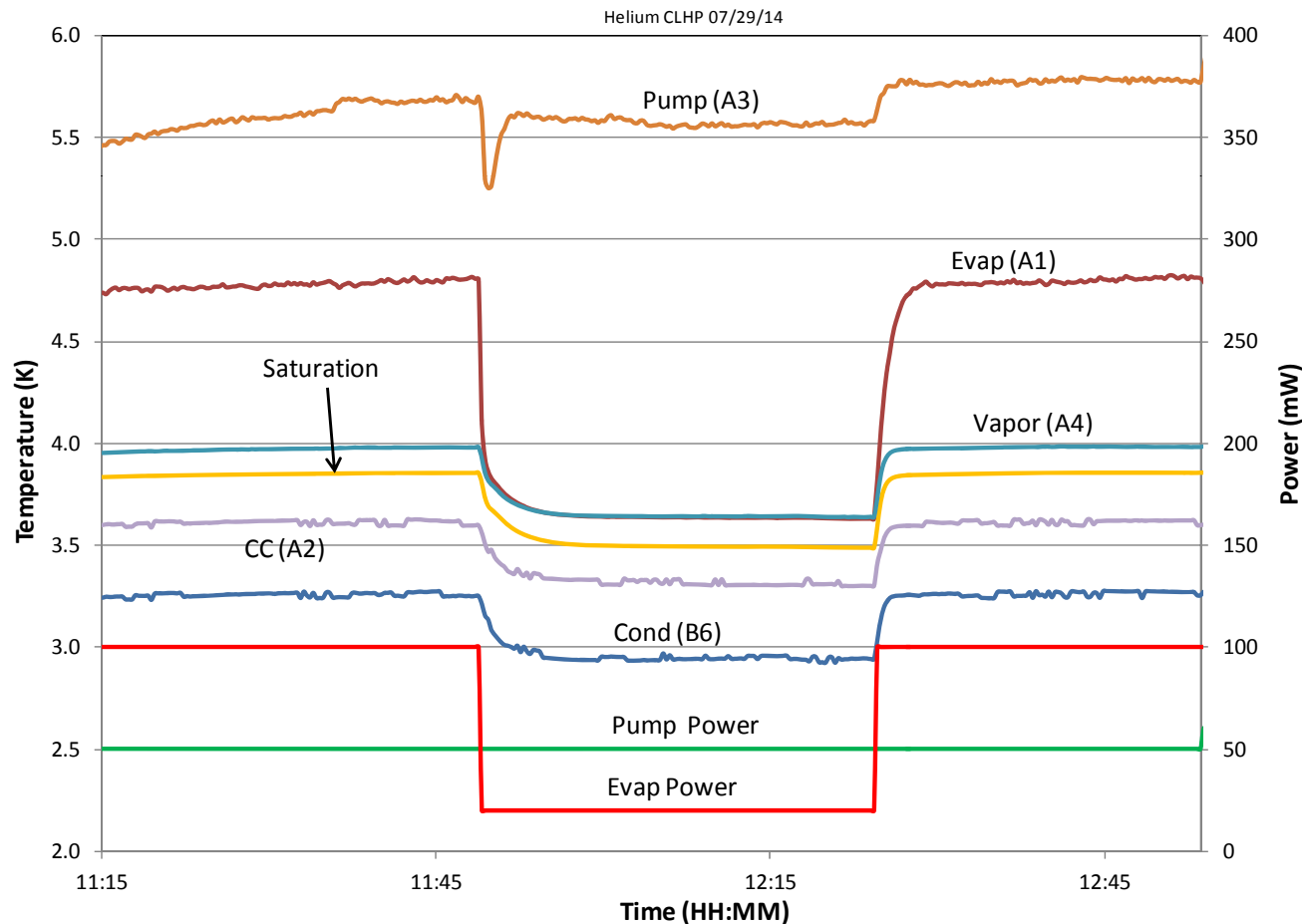

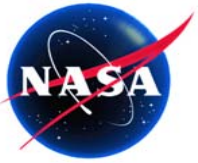

Evaporator Power Cycle

- When evaporator power decreased from 100mW to 20mW, hot vapor was injected from the hot reservoir to the loop, as evidenced by the rise of temperatures of CC inlet and evaporator outlet.
- The fast transient diminished rapidly.

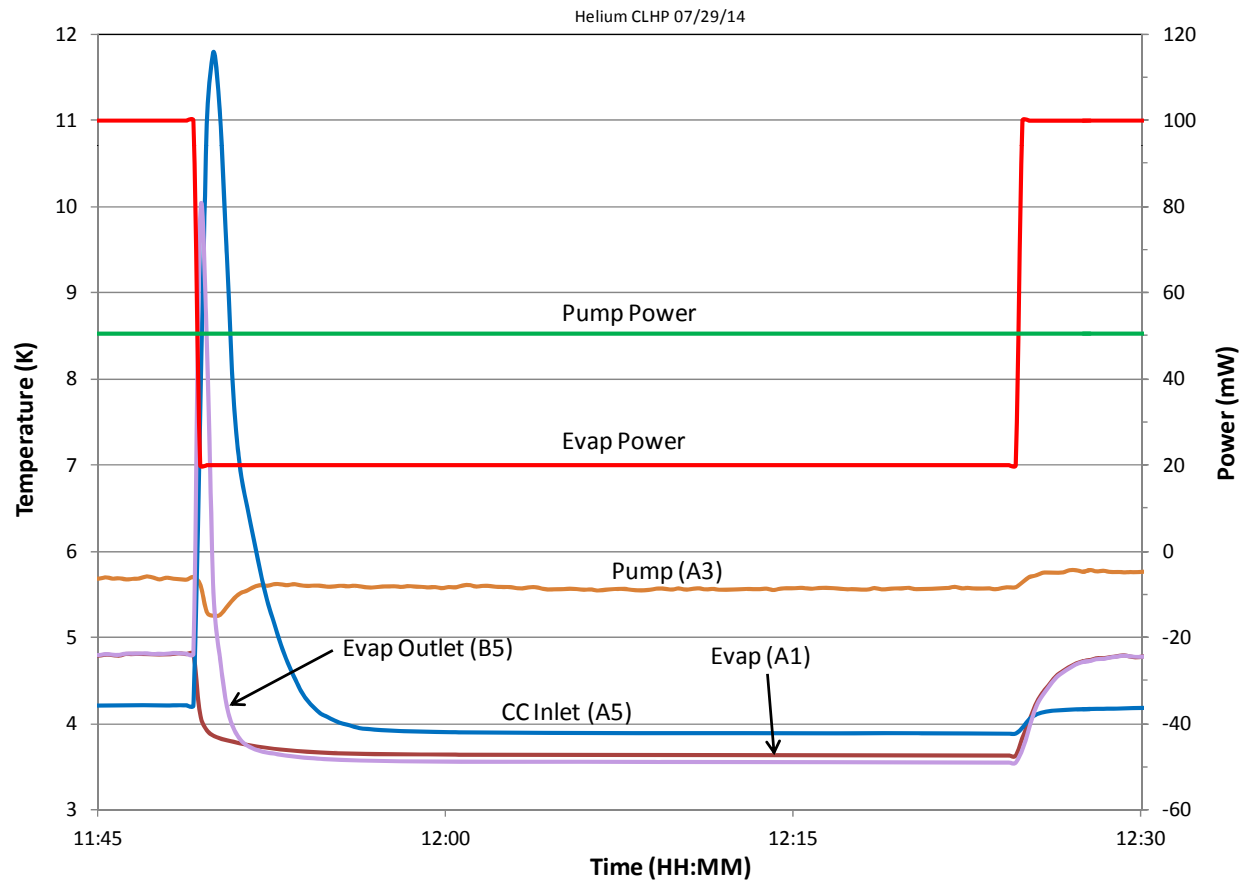

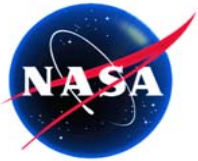

Evaporator Power Cycle

- Pump power was kept constant at 40mW.
- When evaporator power decreased from 80mW to 20mW, hot vapor was injected from the hot reservoir to the loop, as evidenced by the rise of temperatures of CC inlet and evaporator outlet.
- The fast transient diminished rapidly.

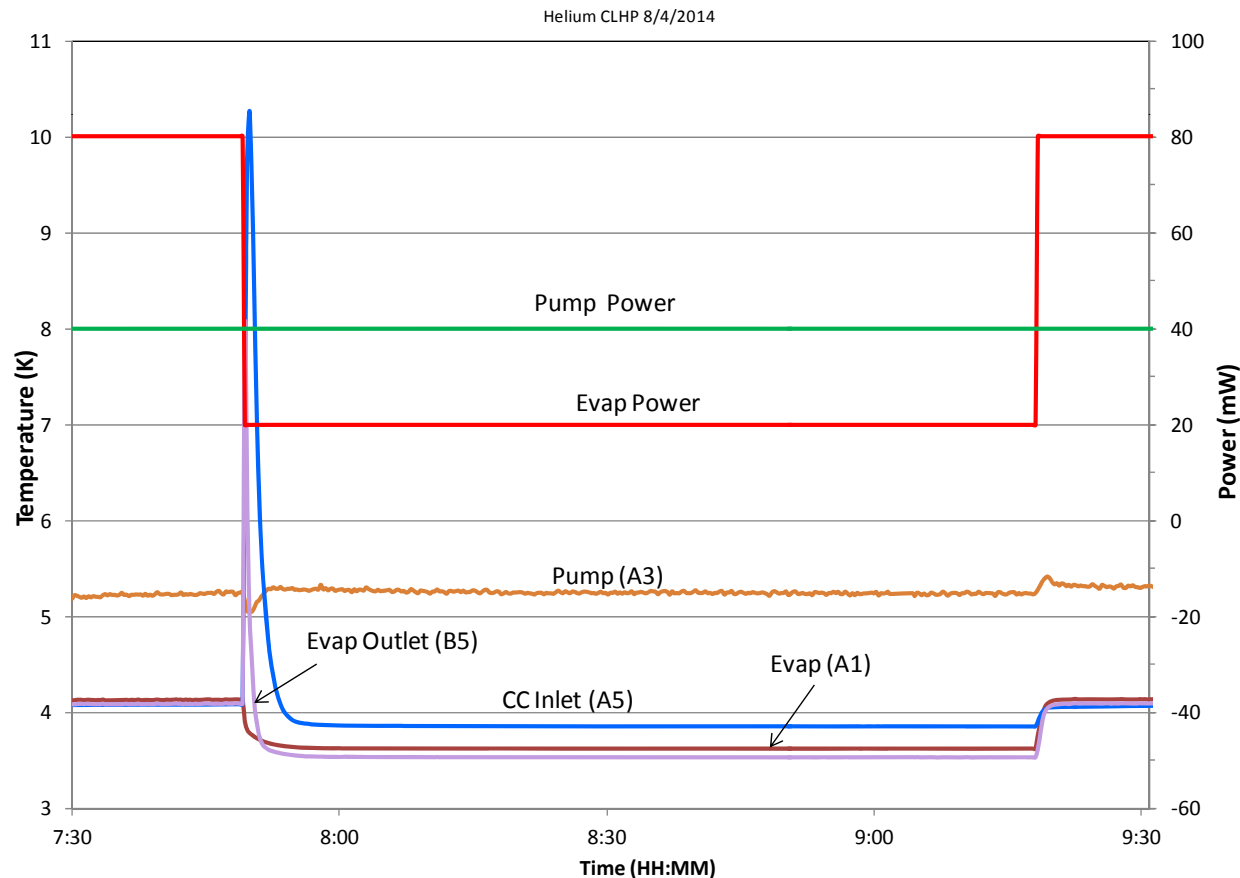

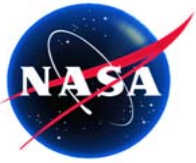

Pump Capillary Limit

- The pump capillary limit was identified by a steep increase of the evaporator temperature when the pump power increases while keep evaporator power at 100mW.
- Pump capillary limit found: between 80mW/100mW and 90mW/100mW.
- The capillary pump recovered from deprime when the pump power reduced from 90mW to 50mW.

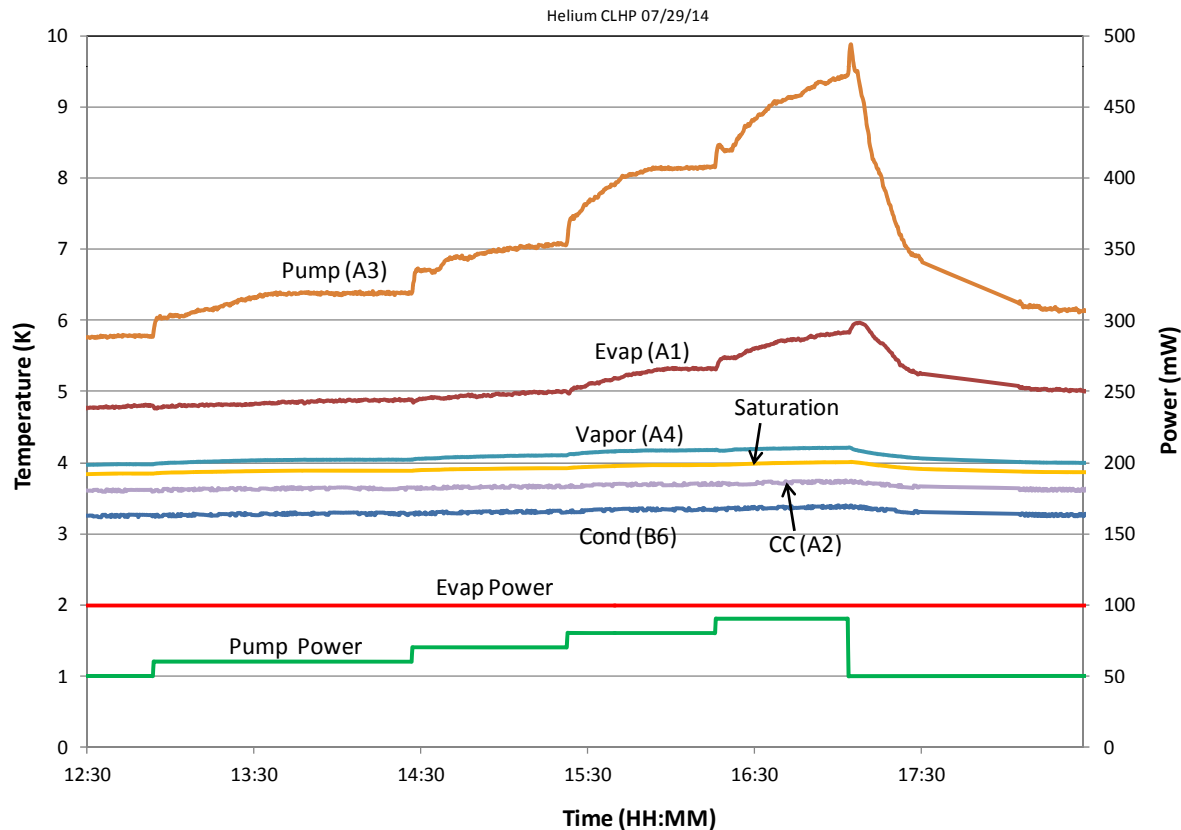

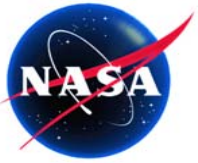

Pump Capillary Limit

- The pump capillary limit depends on the pump power and evaporator power .
- This test showed the capillary limit was between 80mW/100mW and 90mW/100mW. The capillary pump recovered from deprime when the pump power reduced from 90mW to 50mW.

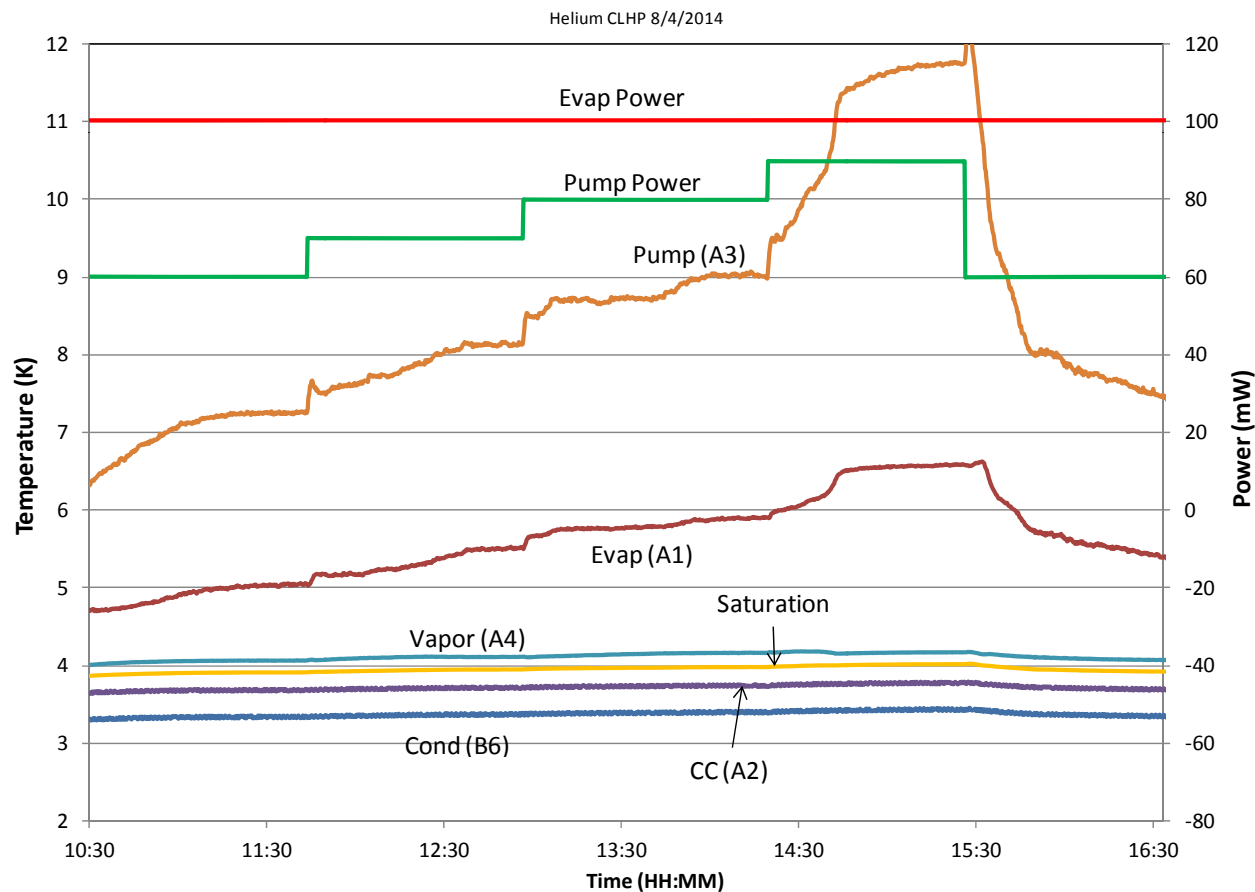

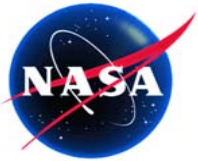

Long Duration Operation (50mW/100mW)

- Steady operation at 50mW/100mW for 11 hours from 8:30pm to next day 7:30am.
- Other tests: 40mW/80mW, 30mW/60mW, 20mW/40mW, 10mW/20mW

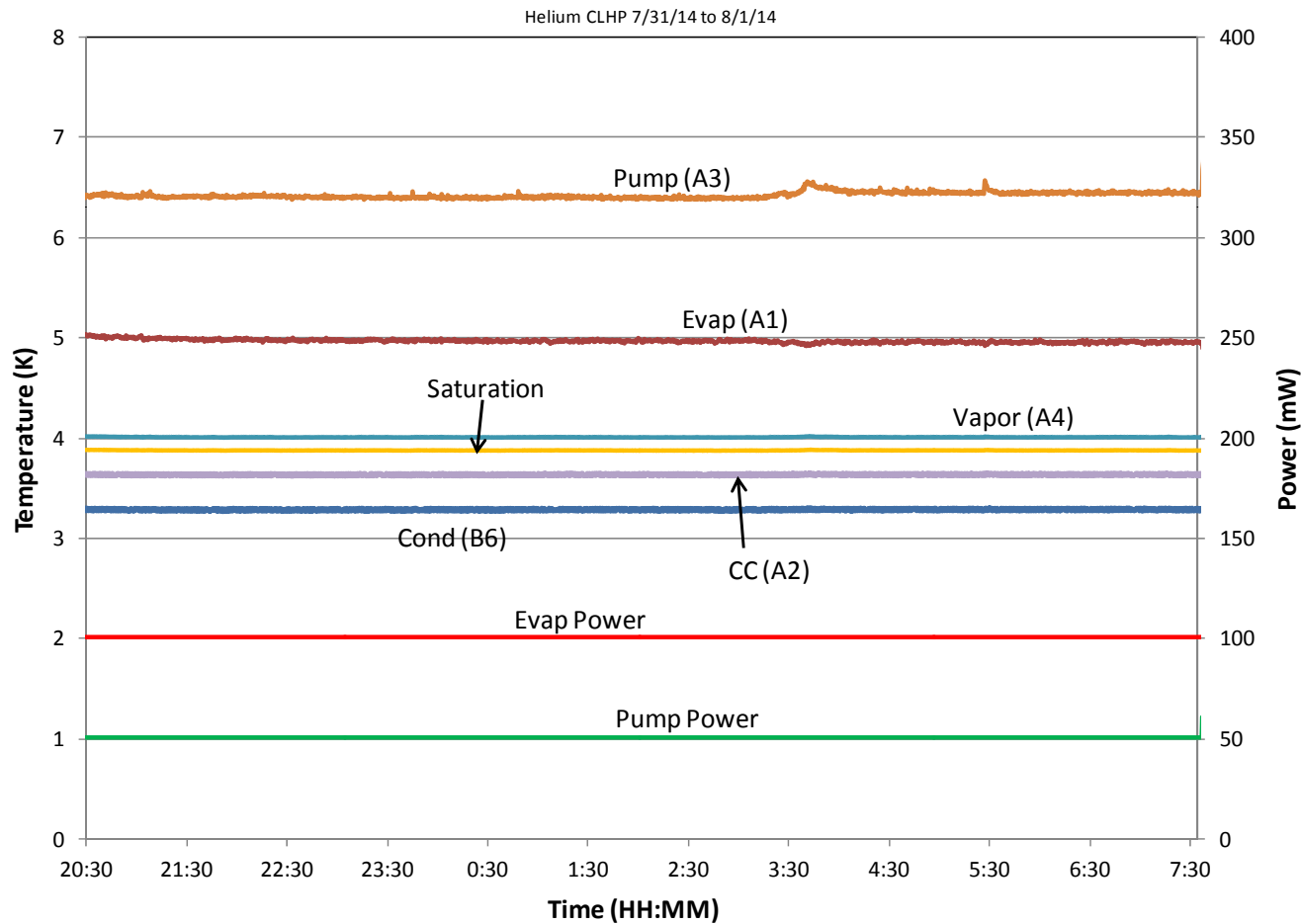

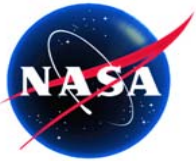

Long Duration Operation (30mW/60mW)

- One continuous SS test at various powers lasted for 58 hours.
- Steady operation at 30mW/60mW for 10.5 hours (1pm to 11:30pm) is shown below, with smooth transitions from 40mW/80mW to 30mW/60mW and from 30mW/60mW to 30mW/45mW.

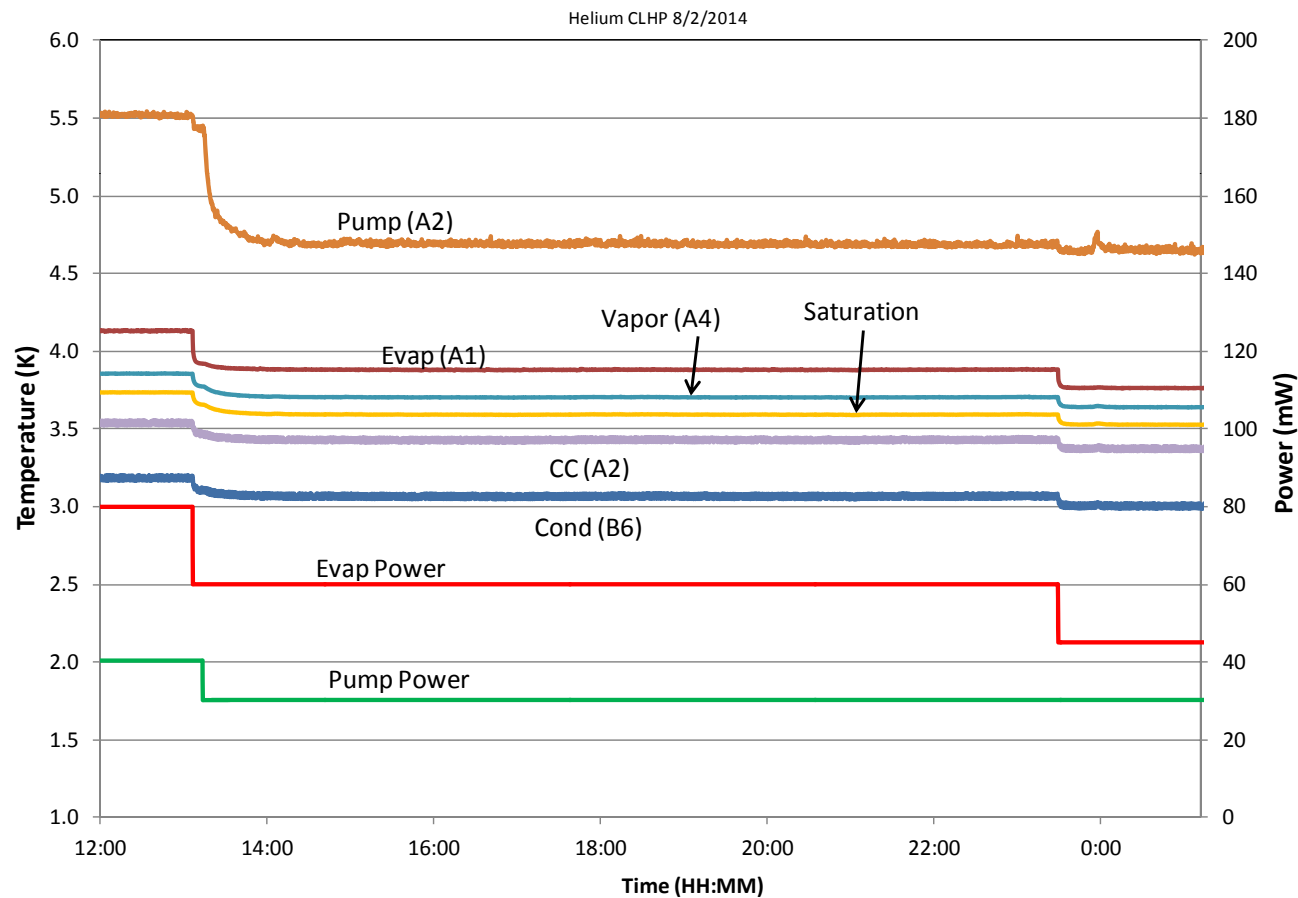

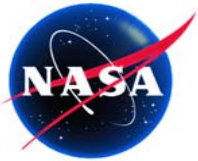

Summary and Conclusions

- **The helium CLHP demonstrated robust operation under steady state and transient conditions.**
- **The CLHP could be cooled from the ambient temperature to subcritical temperatures very effectively.**
- **The CLHP could start successfully by applying power to the capillary pump and the evaporator without any pre-conditioning.**
- **The CLHP could adapt to rapid changes in the pump power and/or evaporator power, and reach a new steady state quickly.**
- **The evaporator could remove heat loads between 10mW and 140mW.**
- **The CLHP demonstrated steady state operations for up to 17 hours.**
- **The helium CLHP demonstrated excellent performance and verified the feasibility of using a CLHP for large area cryocooling.**
- **In addition to cooling the mirrors of large space telescopes and detector arrays, the CLHP can also be used in applications such as the zero boil-off cryogen tank, fluid transfer lines, and thermal energy storage devices.**

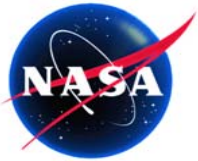

Acknowledgements

Funding for this test program was provided by NASA Engineering & Safety Center's Passive Thermal and Propulsion Technical Discipline Teams. The Technical Monitors were Messrs Steven Rickman and the late Roberto Garcia.

Thanks also go to Dr. Triem Hoang and Ms. Tamara O'Connell for their valuable advices during the course of this investigation.