

Loop Heat Pipe Startup Behaviors

Jentung Ku
NASA Goddard Space Flight Center
Greenbelt, Maryland, USA
301-286-3130
Jentung.Ku-1@nasa.gov

46th International Conference on Environmental Systems
Vienna, Austria, July 10-14, 2016

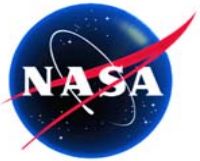

Outline

- **Introduction**
- **LHP Operation – Background**
- **LHP Startup Scenarios**
- **Fluid Distribution Between Evaporator and Reservoir**
- **Enhancing Start-up Success**
- **Other Startup Issues**
- **Summary and Conclusions**

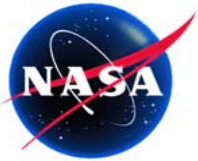

Introduction/Background

- **LHPs have been used for instrument thermal control on many orbiting spacecraft.**
- **An LHP must start successfully before it can commence its service.**
- **The way an LHP starts may affect its subsequent operations.**
- **The startup of the LHP is one of the most complex transient phenomena in LHP operation.**
- **This presentation focuses on the issues related to the startup of a single-evaporator LHP servicing a heat source all by itself.**

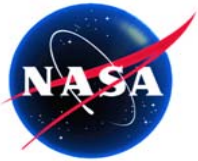

Schematic of a Loop Heat Pipe

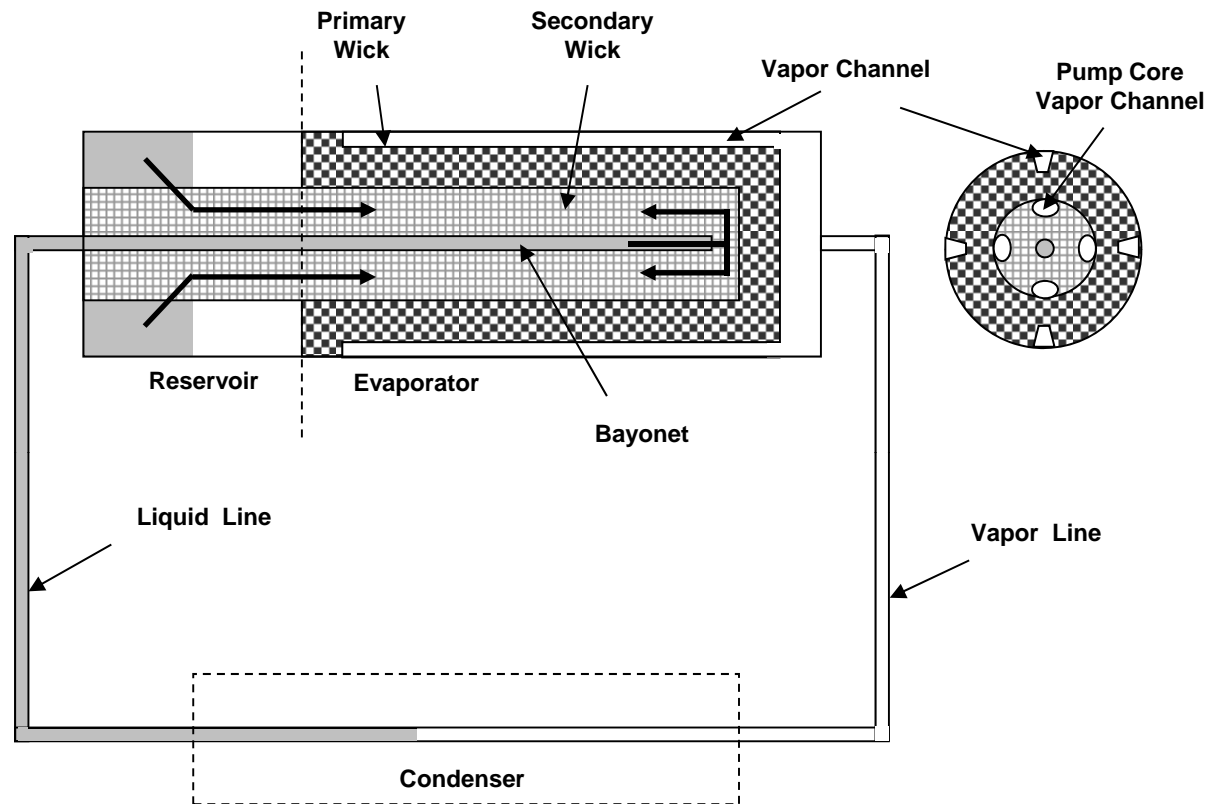

- The reservoir forms an integral part of the evaporator assembly.
- The primary wick with fine pore sizes provides the pumping force.
- The secondary wick connects the reservoir and evaporator, supplying liquid.

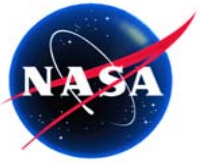

LHP Startup Scenarios

- **Temperature Overshoot and Undershoot during Start-up**
- **Four Start-up Scenarios**
- **Start-up Success**
- **Effect of Heat Load on Start-up Success**
- **Flow Reversal**

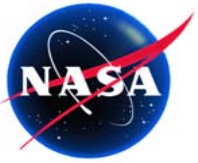

Temperature Overshoot During Start-up

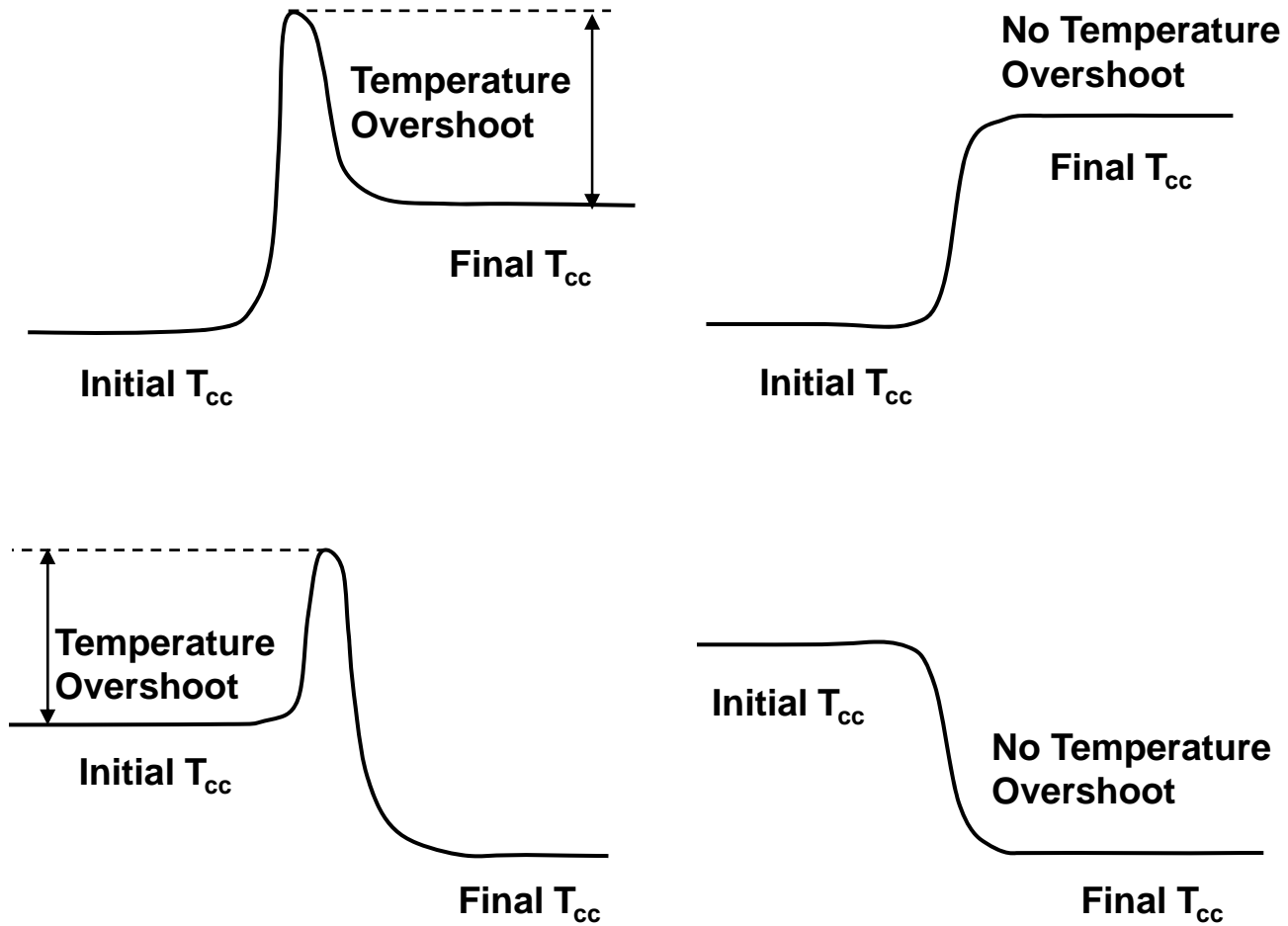

Temperature undershoot can be defined in a similar manner.

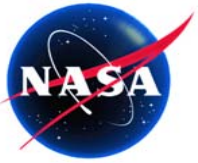

Four Start-up Scenarios for LHP

- **Vapor grooves**
 - Liquid filled: superheat is required for nucleate boiling
 - Vapor presence: instant evaporation

- **Liquid core**
 - Liquid filled: low heat leak
 - Vapor presence: high heat leak

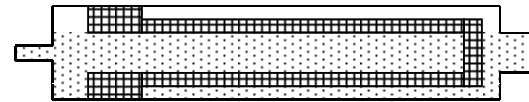
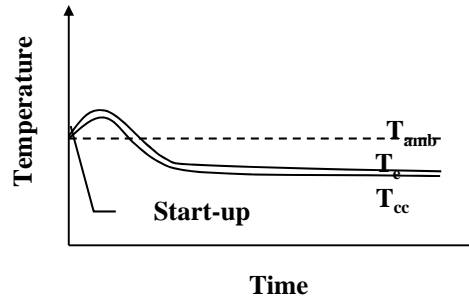

(a) Situation 1

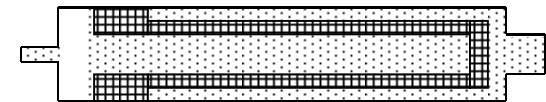
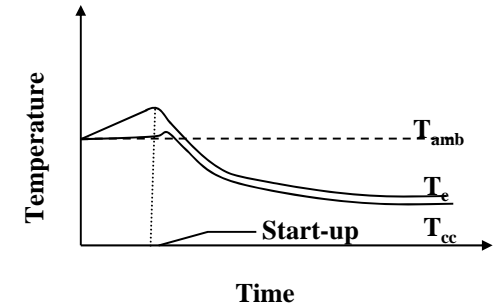

(c) Situation 3

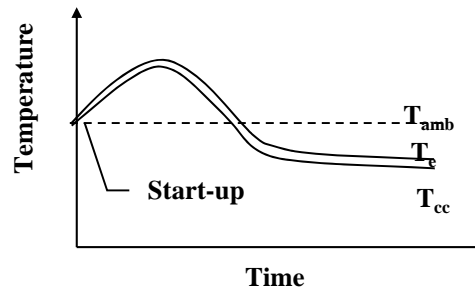

(b) Situation 2

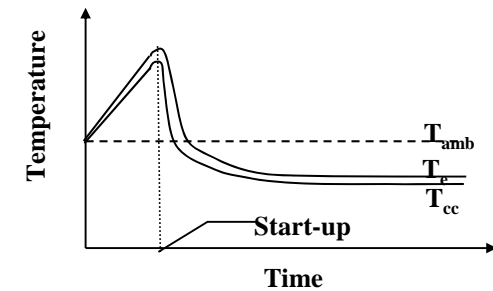

(d) Situation 4

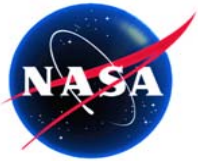

Start-up Success

- **The beginning of liquid evaporation or nucleate boiling in vapor grooves is characterized by the rise of the vapor line temperature to near the reservoir saturation temperature and the drop of the liquid line temperature.**
- **A successful start-up is characterized by:**
 - **The vapor line temperature is the same as or close to the reservoir temperature;**
 - **The evaporator temperature is higher than the reservoir temperature by an amount determined by the heat load and the evaporator thermal conductance;**
 - **The liquid line temperature is lower than the reservoir temperature;**
 - **Temperatures of the reservoir, evaporator, vapor line and liquid line approach their respective steady state temperatures asymptotically.**

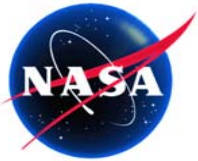

High and Low Power Start-up

- **With high power to the evaporator, liquid in the vapor grooves can be vaporized quickly regardless of the initial two-phase status in the grooves and the evaporator core.**
 - The required superheat, if any, can be achieved in a short time.
 - Within the short time, the total heat leak is small.
- **With low power to the evaporator, start-up could be problematic.**
 - Under situation 4, the required superheat for nucleate boiling may never be achieved.
 - A reverse flow may occur prior to nucleate boiling.
 - After the loop starts, a steady state may not be established within the allowable temperature limit at low powers due to a high heat leak from evaporator to CC if the core contains vapor.

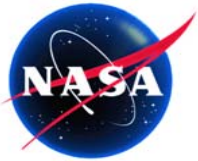

Unsuccessful Startup Under Situation 4

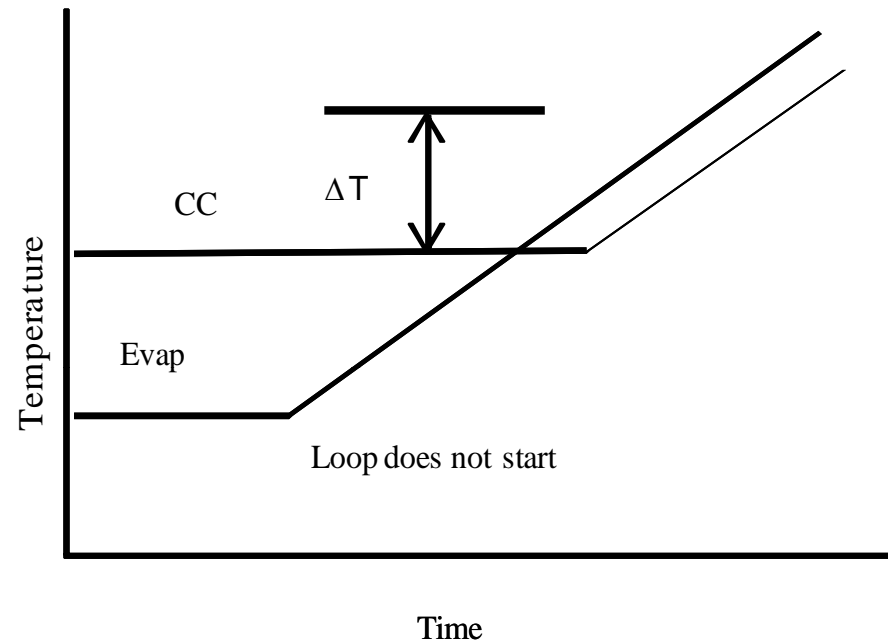

- The vapor grooves are filled with liquid, and a superheat is needed to initiate nucleate boiling.
- Because of the high heat leak from the evaporator to reservoir, the required superheated was never attained.

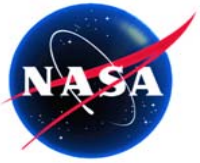

Schematic of LHP-A and Thermocouple Locations

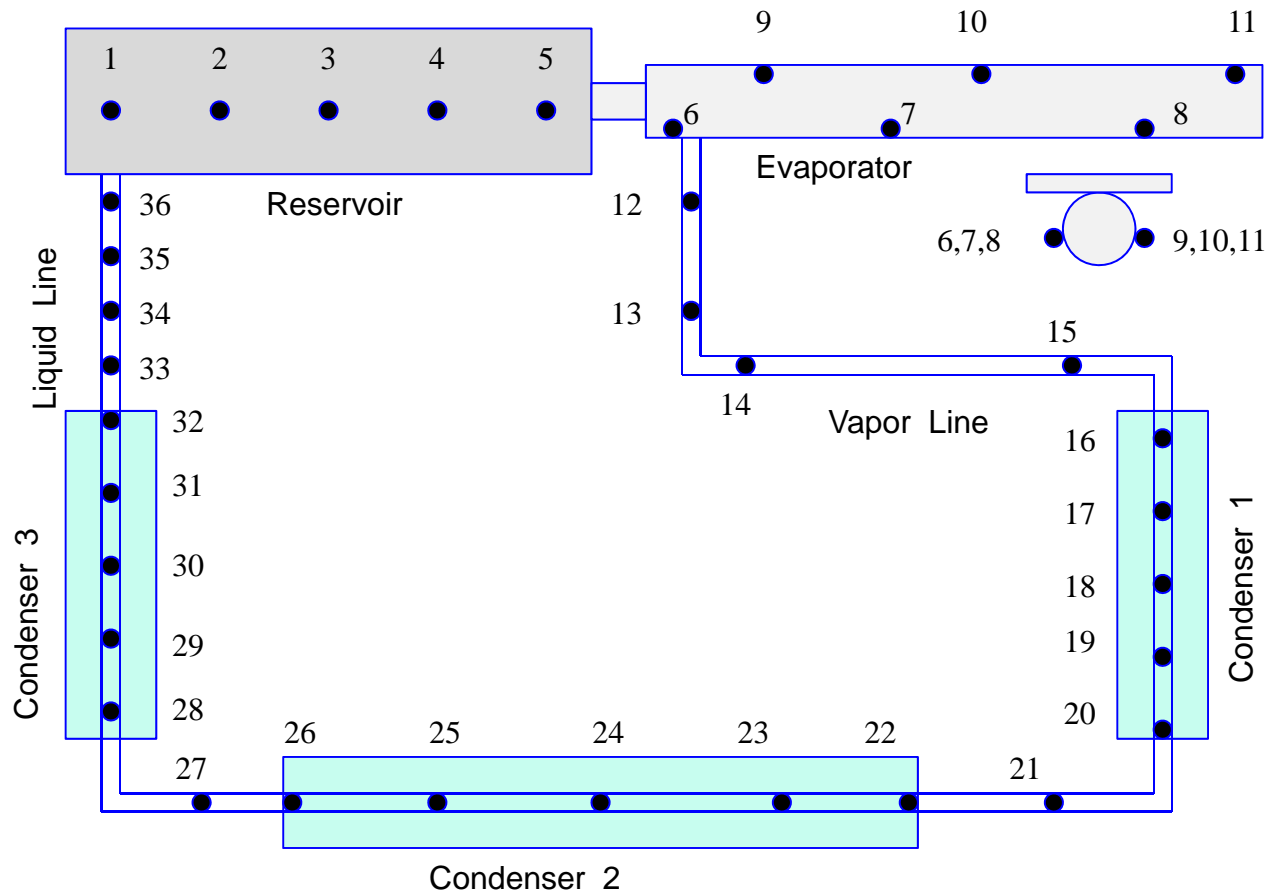

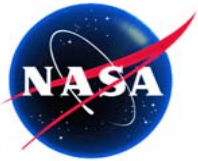

High Power Startup of LHP-A

- **Successful startup with 50W to evaporator**
 - Loop started 3 minutes after power application
 - 4.5K superheat for nucleate boiling
- **This was a situation 3 startup.**
 - The reservoir temperature rose with evaporator because of a heat leak due to heat conduction instead of heat pipe effect.

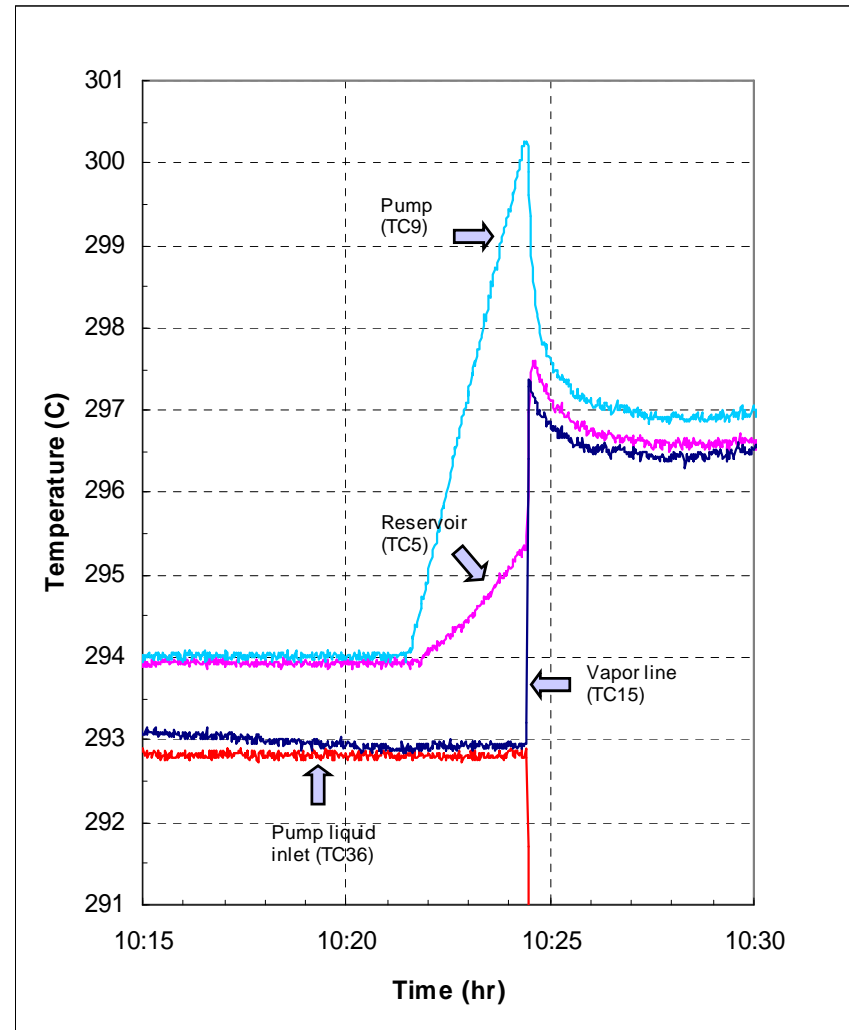

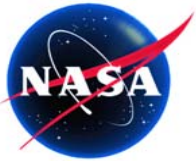

Low Power Startup of LHP-A

- **Successful startup with 5W to evaporator**
 - It took 45 minutes to initiate nucleate boiling
 - 2.5 K superheat for nucleate boiling
 - 4K temperature overshoot
- **This was a situation 4 startup.**
 - Reservoir temperature rose with evaporator (due to heat pipe effect) prior to nucleate boiling.

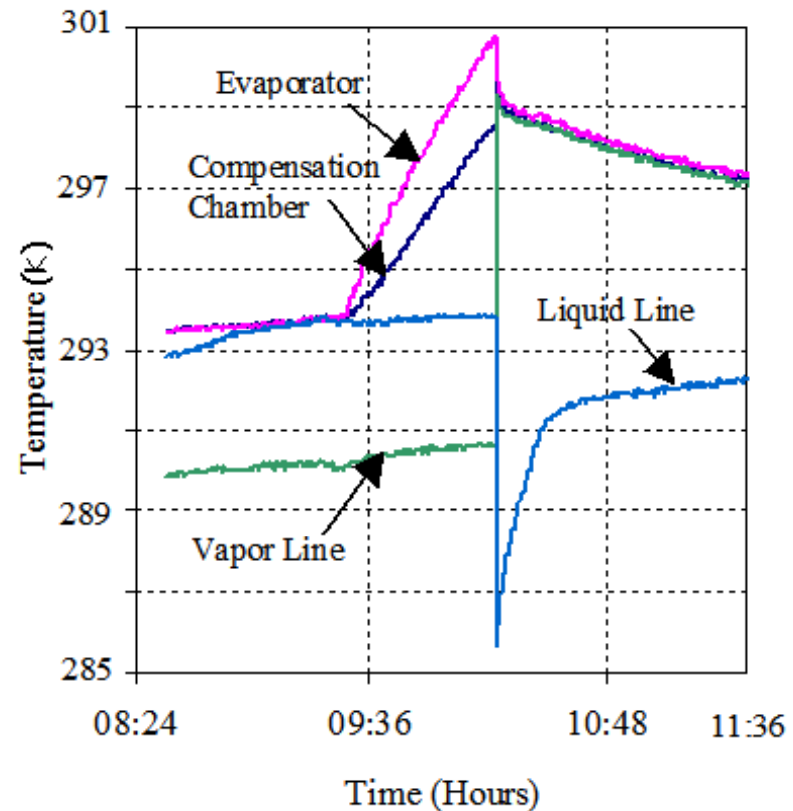

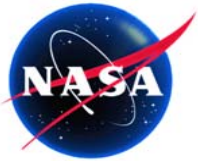

Low Power Startup of LHP-A

- **Adverse elevation - evaporator and reservoir were 690mm above the condenser**
- **Startup with 10W to evaporator**
 - It took 85 minutes to initiate nucleate boiling
 - 2.5 K superheat for nucleate boiling
 - 20K temperature overshoot
- **This was a situation 4 startup.**
 - Reservoir temperature rose with evaporator (due to heat pipe effect) prior to nucleate boiling.

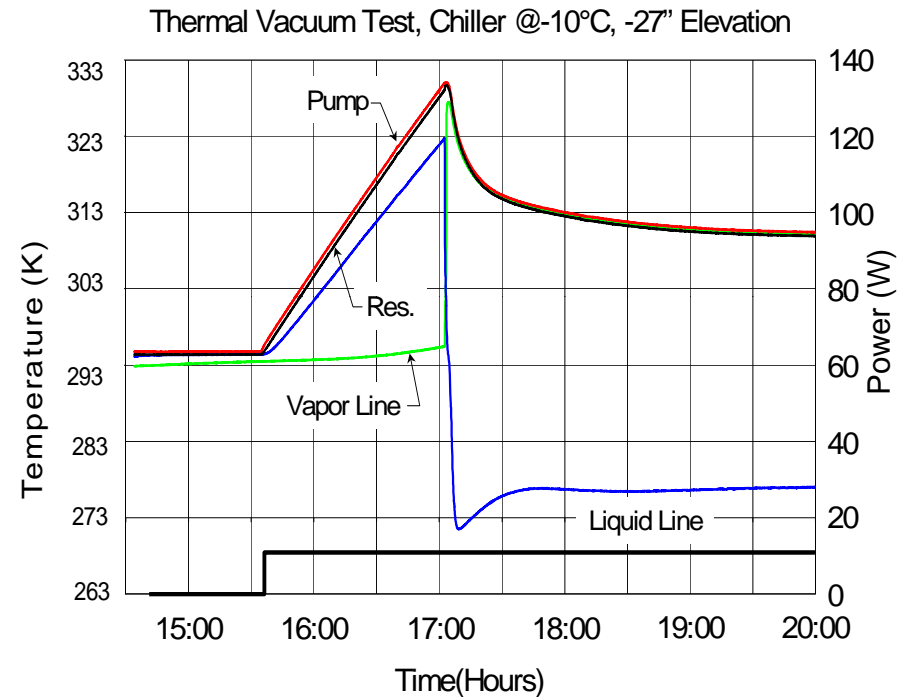

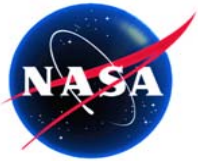

Flow Reversal during Startup Transient

- **Flow reversal during startup typically occurs under Situation 4.**
 - Liquid evaporation takes place at the core of the evaporator.
 - Vapor flow via the liquid line to the condenser.
- **Flow reversal can last from seconds with high power startup to hours with low power startup.**
- **After nucleate boiling, forward flow will be established, and LHP will begin its normal operation.**

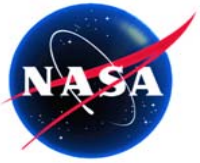

Schematic of LHP-B

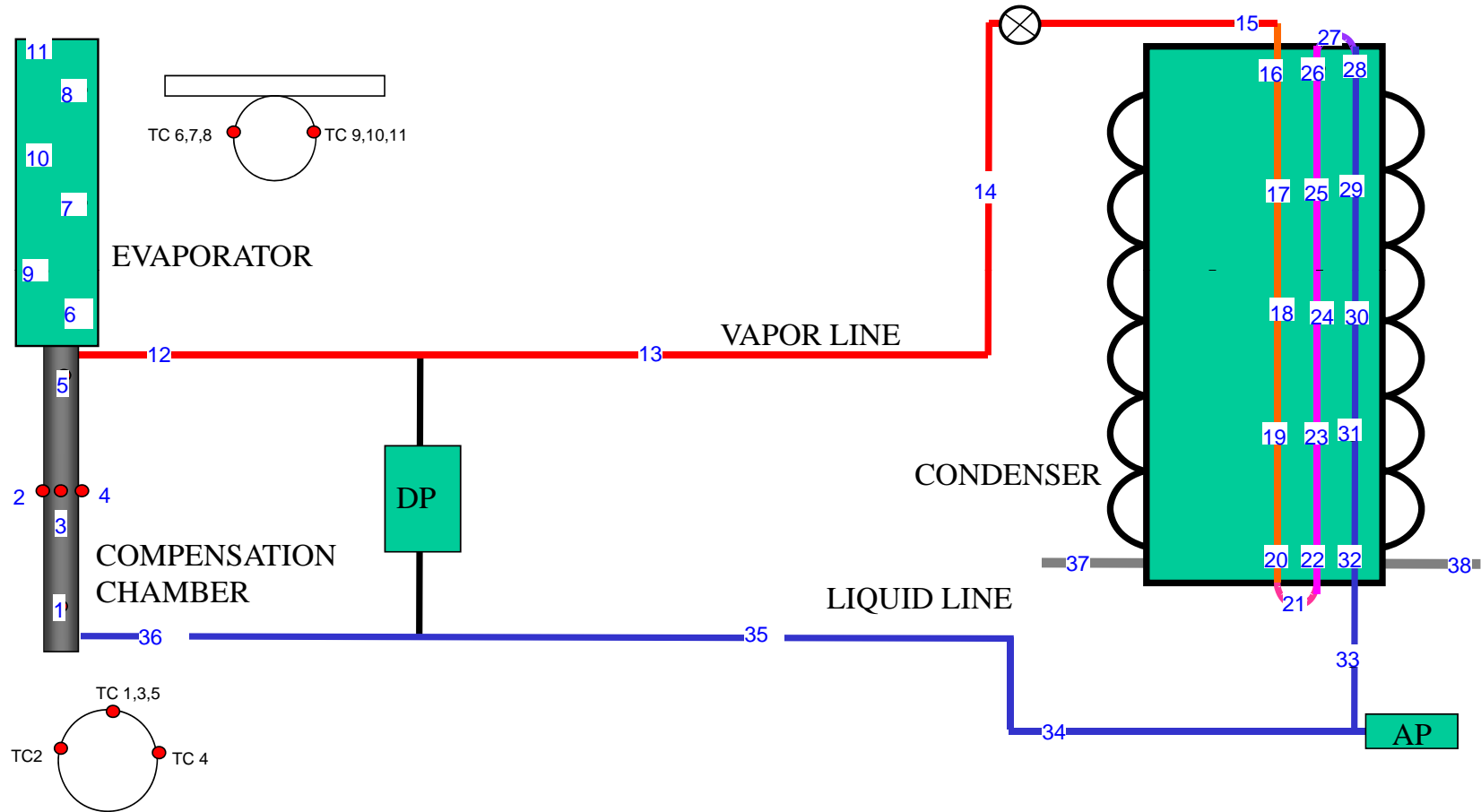

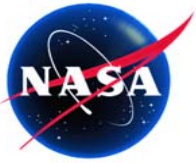

Flow Reversal During LHP-B Startup (100 grams/ +6.35mm/ 5W/ 290K)

- Situation 4 startup under an adverse tilt
- Flow reversal lasted for 4+ hours with 5W without startup.
- Loop started with 100W, then operated at 5W.

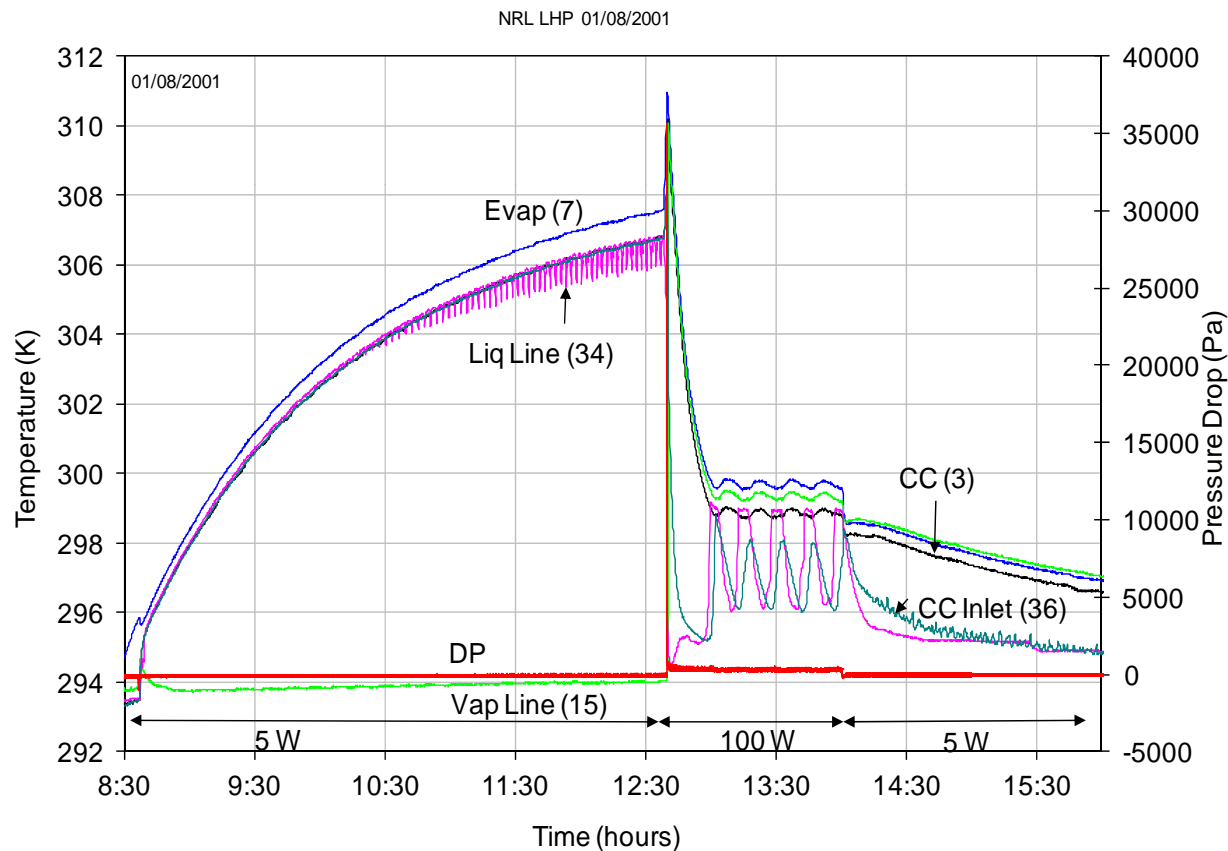

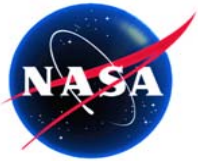

Fluid Distribution in Evaporator and Reservoir

- **Vapor void fraction in the evaporator core strongly affects the LHP startup and low power operation.**
- **Vapor void fraction depends upon the fluid distribution in the evaporator and reservoir.**
- **Factors affecting the fluid distribution**
 - **Fluid inventory**
 - **Pre-conditioning of the loop prior to startup**
 - **Body forces**
 - **Evaporator/reservoir assembly design**
 - **Tilt between evaporator and reservoir**
 - **Elevation between evaporator and condenser**
- **Startup is affected by combinations of factors.**

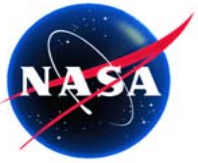

Evaporator Assembly and Gravity Effect on Fluid Distribution

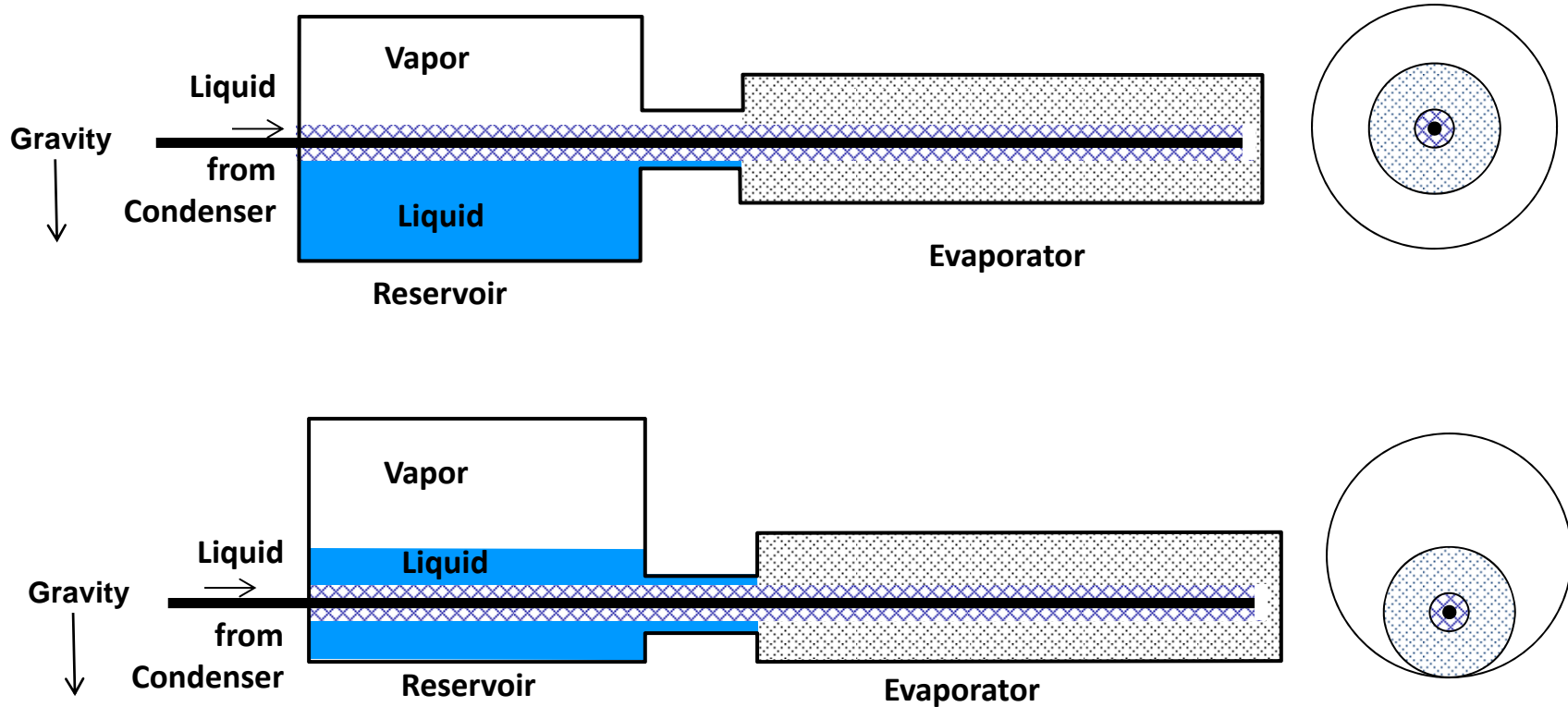

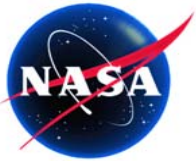

LHP-B Startup Tests

- Fluid inventories: 83 grams, 100 grams, and 113 grams
- Tilts: +6.35mm, 0 mm, and -6.35mm (evaporator end to reservoir end)
- Successful startups with 100W or higher under all conditions
- Startup highly depends on tilts and inventory with <100W
- Successful startups with $\geq 5W$ in all tilts at 100 grams and 113 grams
- Loop could not start with $< 25W$ in all tilts at 83 grams

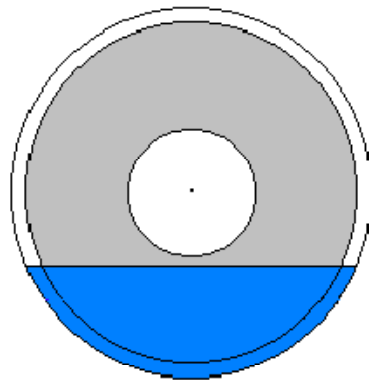

83 grams
32.1% filled
H/D = 0.312

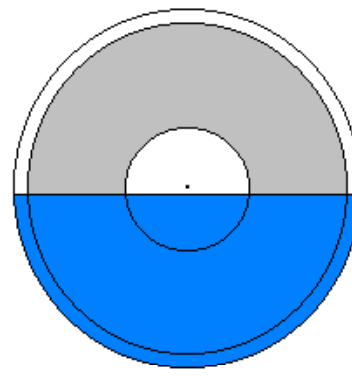

100 grams
49.5% filled
H/D = 0.496

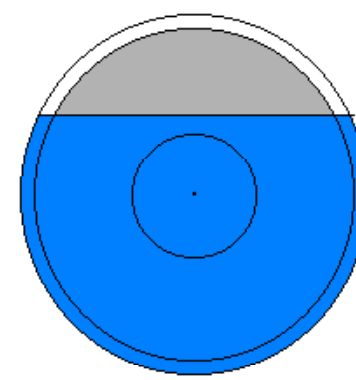

113 grams
71.8% filled
H/D = 0.73

Cross-Sectional View of Evaporator/Reservoir with Various Fluid Inventories

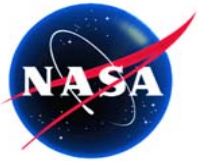

LHP-B Startup - Reverse Flow (100 grams/ 0mm/ 50W/ 270K)

- Situation 4 startup
- Flow reversal lasted for 15 minutes with 50W!
- 20K temperature overshoot

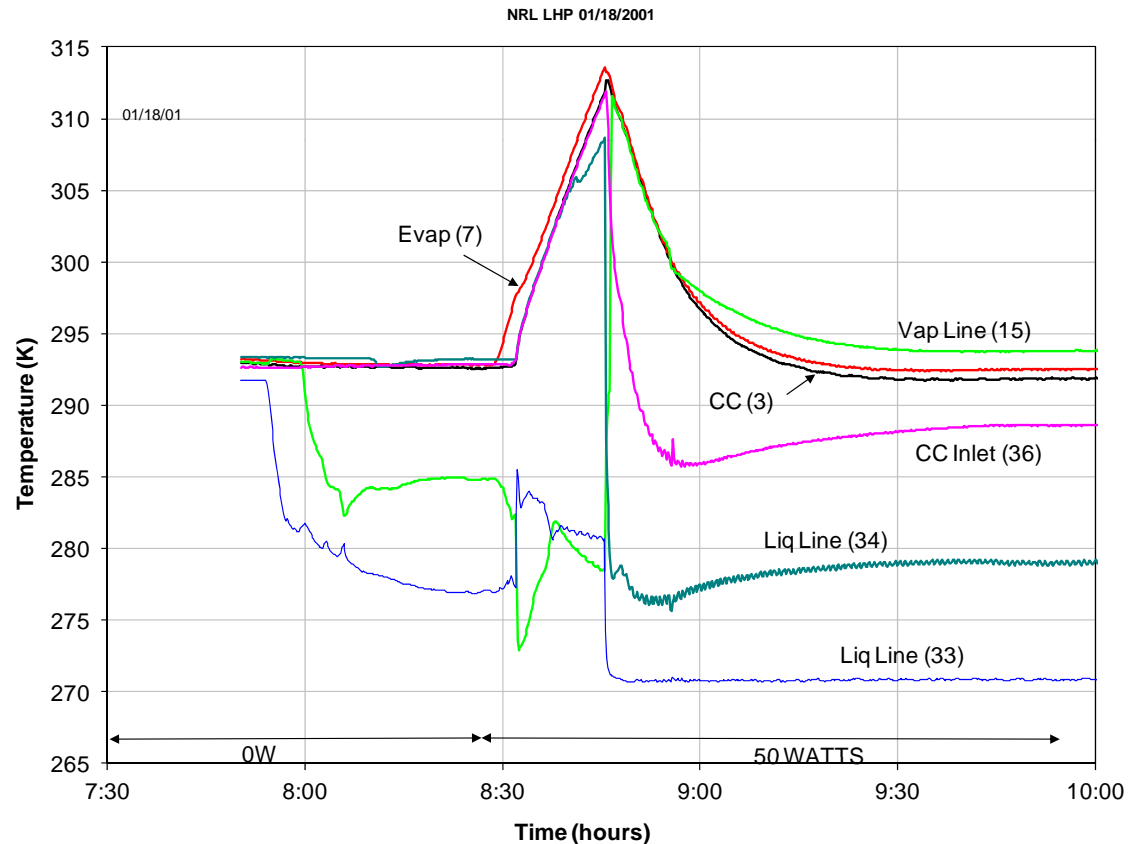

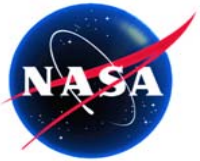

Enhancing Start-up Success

- **Superheat is required for nucleate boiling for Situation 3 and Situation 4 startups**
 - **Situation 3: Loop will start, but may take a long time with low powers.**
 - **Situation 4: Loop may not start with low powers.**
- **Methods to enhance startup success**
 - **Start-up heater**
 - **Thermoelectric converter (TEC)**

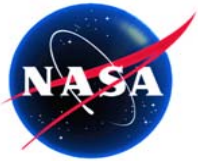

Startup Heaters

- **Use a concentrated heat source over a localized area on the evaporator.**
- **The high heat flux will quickly raise the temperature of liquid in the vicinity of the heater while minimizing the heat leak to the reservoir.**
- **Once nucleate boiling starts and first bubbles are generated, no superheat is required for liquid evaporation.**
- **The startup heater has proven to be very effective in enhancing the startup success.**
- **Many LHPs in flight applications employ such a device because of its simplicity in design and ease in implementation.**

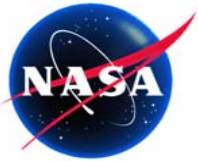

TEC and Thermal Strap

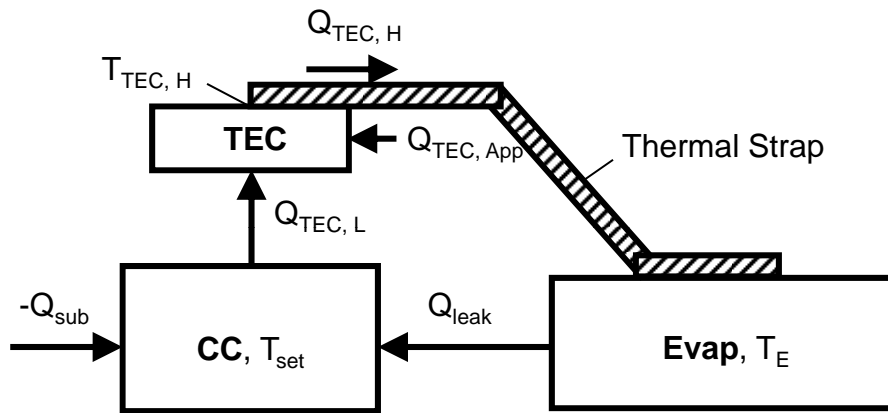

- Heat Flow When TEC Is Cooling the Reservoir

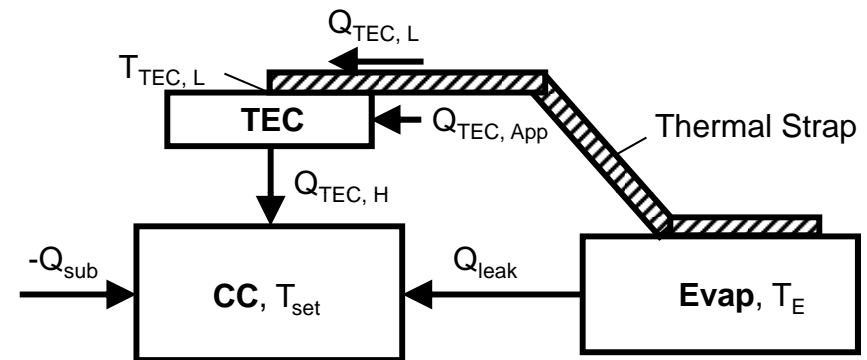

- Heat Flow When TEC Is Heating the Reservoir

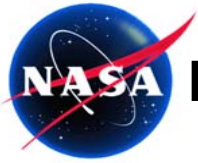

Enhancing LHP Startup Using Thermoelectric Converter (TEC) Situation 4 startup

- Without TEC (Figure A)
 - CC temperature rises with evaporator temperature due to heat leaks.
 - Required superheat may never be attained at low powers.
- With TEC (Figures B and C)
 - TEC can maintain a constant CC temperature to achieve the required superheat, resulting in a successful start-up.
 - TEC can also cool the CC to create the required superheat.
 - Startup heaters can be eliminated.

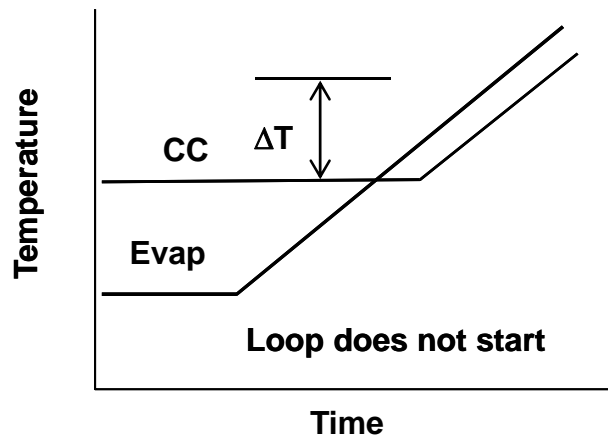

Figure A

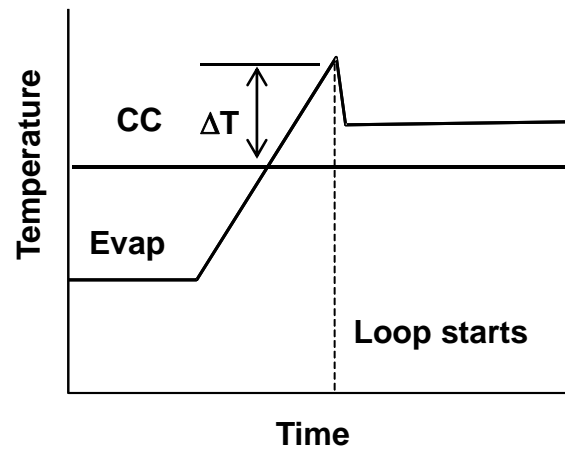

Figure B

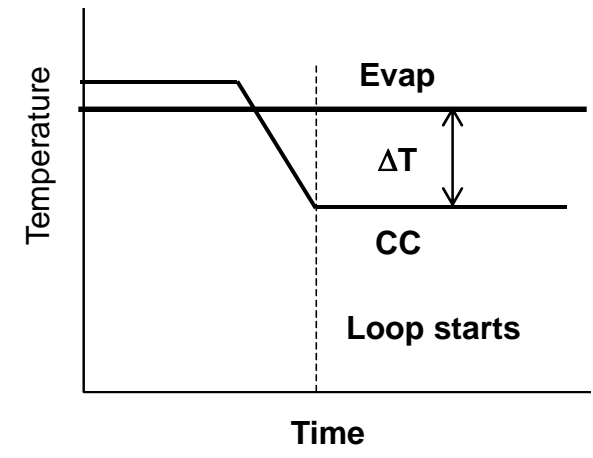
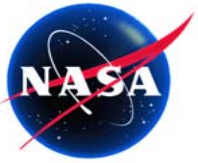
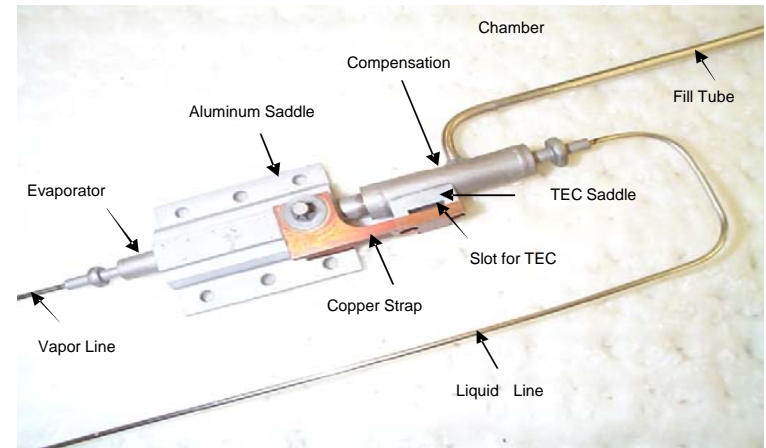
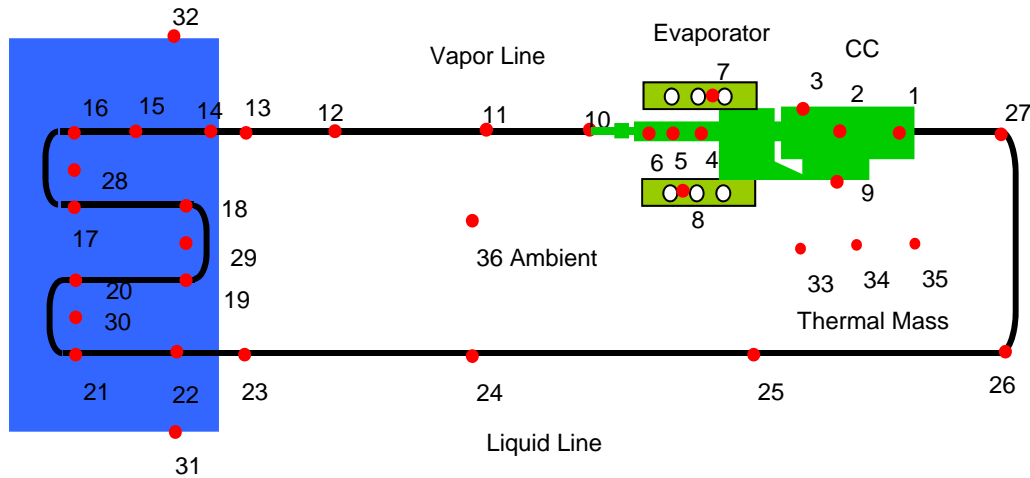

Figure C



LHP-C with TEC and Startup Heaters

- **TEC was installed on evaporator and connected to CC via a thermal strap.**
- **An electric heater was also installed on evaporator to serve as the startup heater**



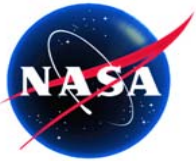

LHP-C Startup with TEC and Startup Heater

- TEC provided required heating and cooling during startup to maintain the CC set point.
- By comparison, a higher temperature overshoot when an electric heater was used for CC temperature control.

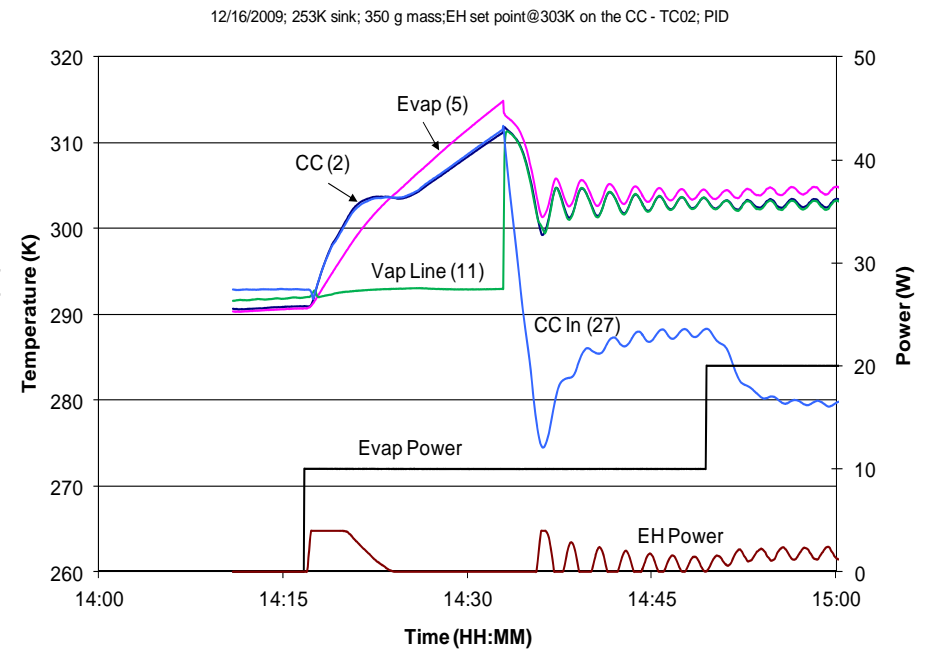
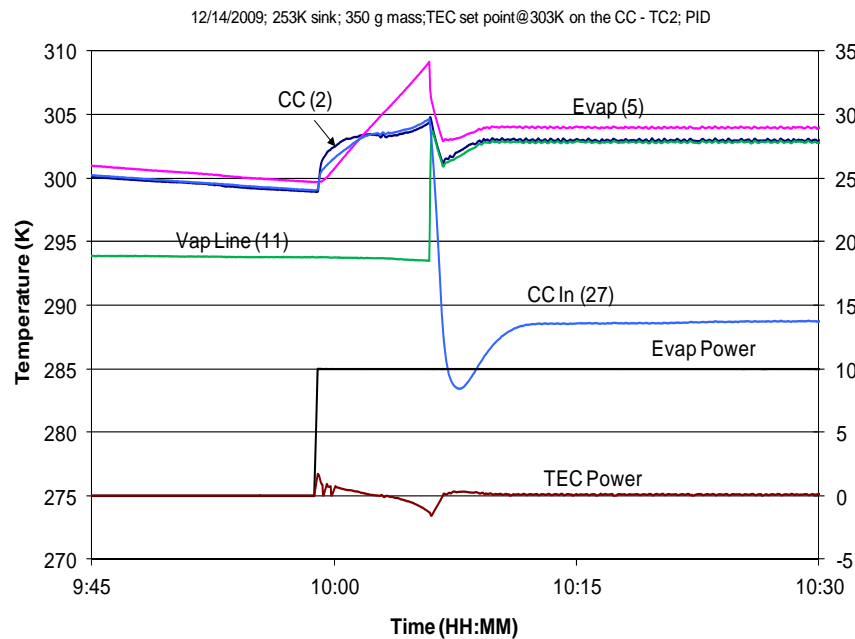

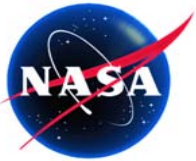

Using TEC to Enhance Start-up Success

- No heat load to the evaporator. TEC was used to cool the reservoir.
- The loop started at 8:17 with a superheat of 2K.
- The heat input to the evaporators came from the power applied to the TECs, and the heat pumped out of the reservoirs.
- Once started, the loop continued to operate. Additional heat came from the sensible heat released from the thermal mass attached to the evaporator

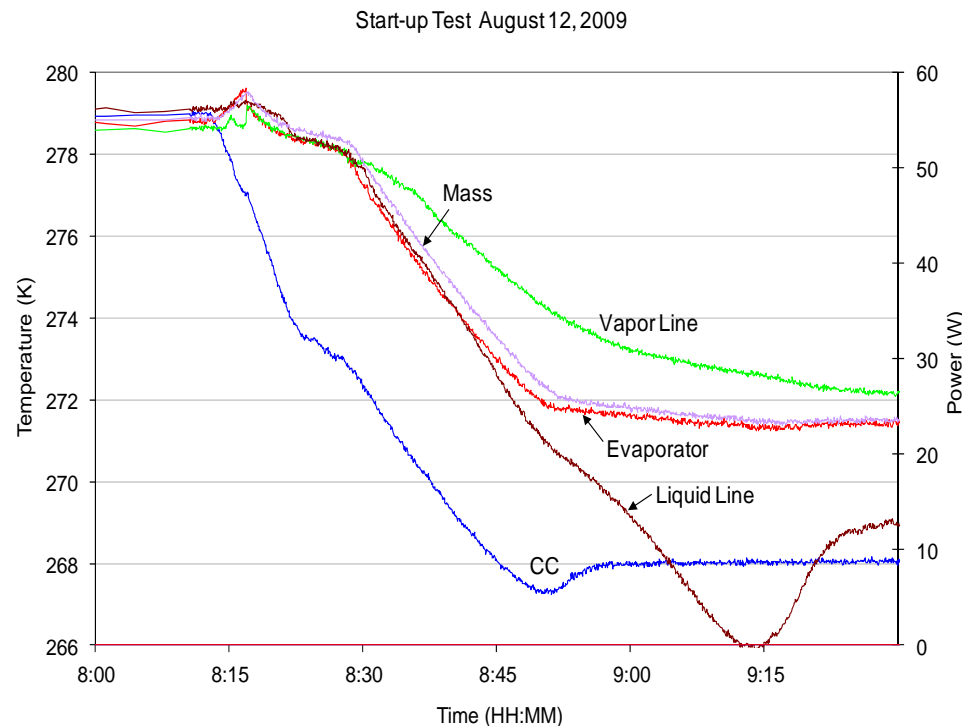

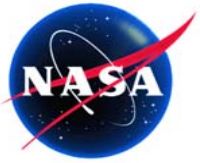

Other Start-up Issues

- **Pressure Spike**
- **Pressure Surge**
- **Reservoir Temperature Undershoot**
- **Repeated Cycles of Loop Start-up and Shutdown**

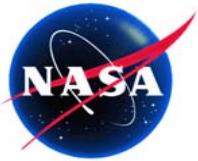

Pressure Spike

- **The required superheat for nucleate boiling can be higher than 10K.**
- **Right after nucleate boiling, the vapor bubble will absorb the sensible heat stored in the superheated liquid and grow rapidly.**
- **The growth of the vapor bubble is similar to an explosion.**
- **Experimental data shows that the pressure differential across the evaporator can be as high as 45 kPa.**
- **Such a high pressure drop may exceed the capillary limit of the primary wick and cause the vapor to penetrate the wick to reach the evaporator core.**
- **However, the high pressure drop only lasted for fractions of a second.**
- **Because of the short duration of the pressure spike and the ability of the LHP to tolerate a vapor bubble in the evaporator core, no LHP deprime due to the pressure spike has been observed.**

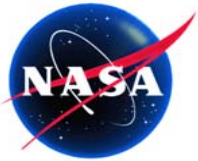

Pressure Surge

- **After the boiling incipience, liquid in the vapor line is swept into the condenser.**
- **Liquid moves toward the reservoir at the same volumetric flow rate as the vapor is being generated in the vapor grooves.**
- **The liquid mass flow rate along the condenser and liquid line can be two orders of magnitude higher than its steady state value at the same heat load during the normal operation of the LHP.**
- **A high flow rate induces a surge of the pressure drop that is imposed on the primary wick until vapor reaches the condenser.**
- **The magnitude and duration of the pressure surge depend on the working fluid, saturation temperature, heat load, volume of the vapor line and vapor grooves, and initial vapor line temperature.**
- **The pressure surge is more severe at a low reservoir temperature.**
- **An LHP can usually sustain the pressure surge without any problem due to its high capillary capability.**

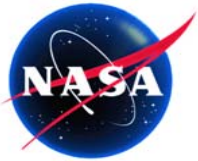

Repeated Cycles of Loop Startup and Shutdown

- **When a severe reservoir temperature undershoot happens, the reservoir control heater will be turned on.**
- **If the heater power is so large that it raises the reservoir temperature faster than the evaporator can catch up, the loop will be flooded with liquid again by the time the reservoir reaches its set point temperature.**
- **The re-start will follow the same process as the previous startup. In some cases, this leads to repeated startup and shutdown cycles.**

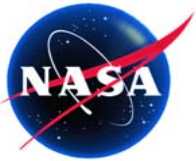

Repeated Startup/Shutdown Cycles in LHP-C

- Control sensor was placed on the thermal mass to maintain its set point at 313K.
- Control heater (electrical) was attached to the CC.
- Repeated startup/shutdown cycles with 10W and 20W to thermal mass.
- Successful startup with 40W to thermal mass.

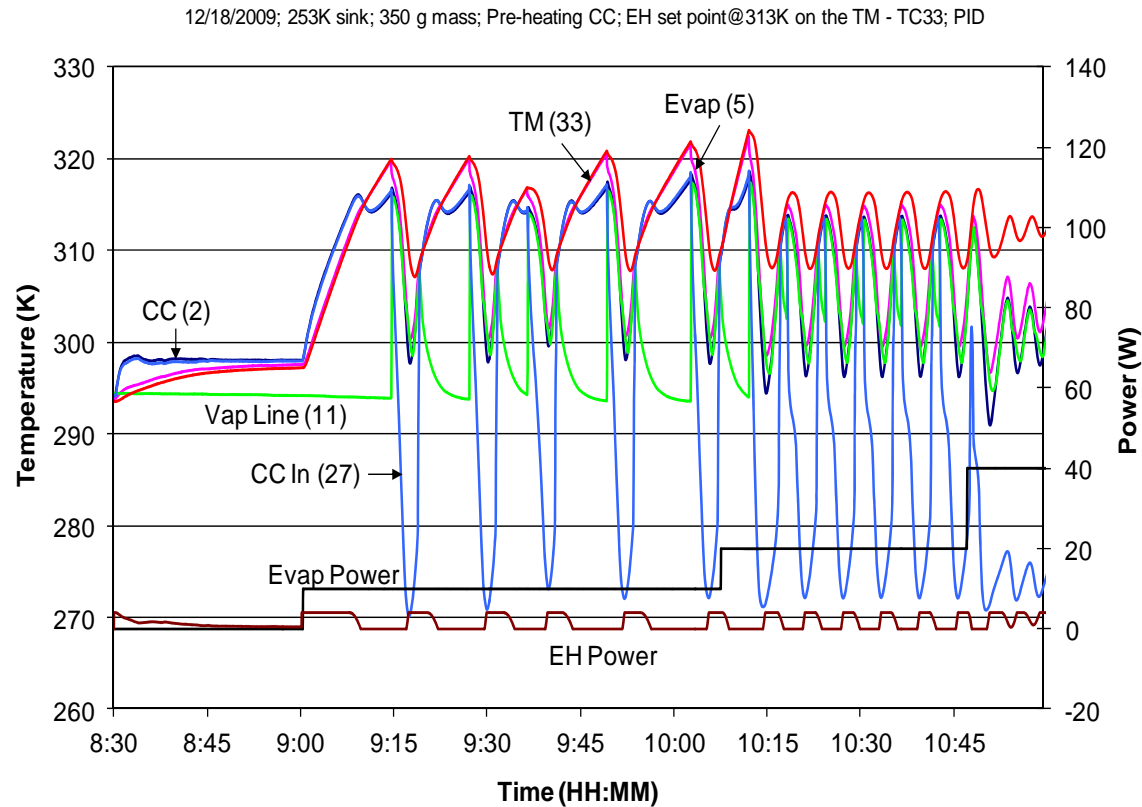

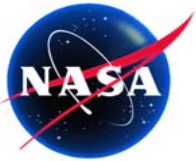

Summary and Conclusions

- **LHP startup is one of most complex transient phenomena.**
- **There are four possible startup scenarios, which are determined by the initial fluid distribution between evaporator and CC.**
- **Several factors affect fluid distribution between evaporator and CC.**
 - **Fluid inventory**
 - **Pre-conditioning**
 - **Body forces, e.g. gravity**
 - **Evaporator/CC assembly design**
 - **Tilt between evaporator and reservoir**
 - **Elevation between evaporator and condenser**
- **Startup success is a function of startup scenario, power to evaporator, and how the CC temperature is controlled.**
- **Using a startup heater or a thermoelectric converter can greatly enhance startup success.**
- **Repeated startup and shutdown cycles can happen. This can be avoided or mitigated by using a smaller increments for reservoir temperature rise.**

