

# Astrobee

## Space Station Robotic Free Flyer



POIWG #50  
July 28, 2016

Maria Bualat  
NASA Ames Research Center  
Intelligent Robotics Group



# Project Summary

- Develop, test, deliver 2 free flying robots for ISS IVA use
- 3 year project (FY15-FY17) under Human Exploration Telerobotics 2 (HET2)
- 1 year (FY18) extension for on-orbit commissioning (proposed)
- Sponsor: Space Technology Mission Directorate, Game Changing Development Program
- Technology infusion to ISS payloads & operations

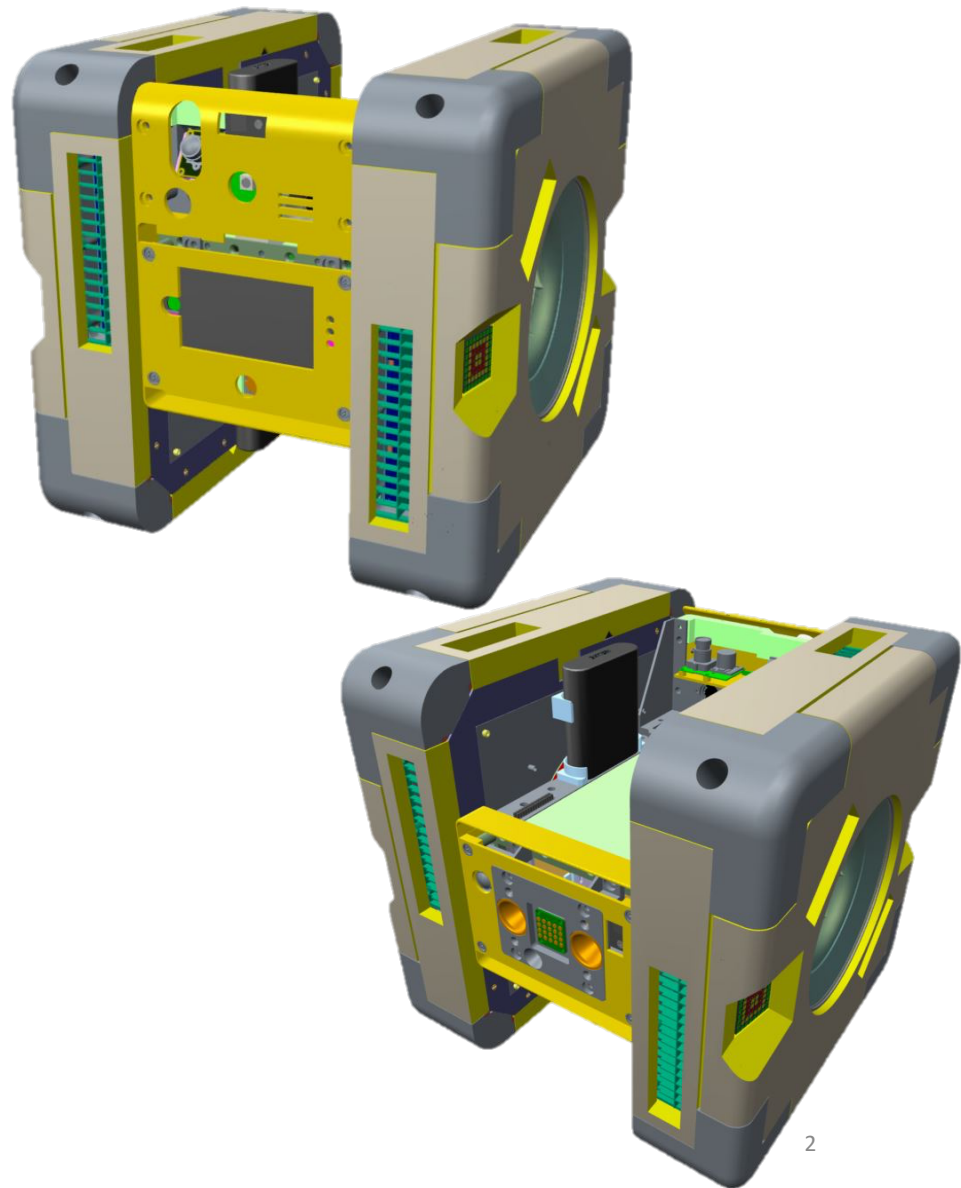



# 0g Robotics Research Facility



AES, SPHERES Program, SPHERES users



# Mobile Camera Tasks

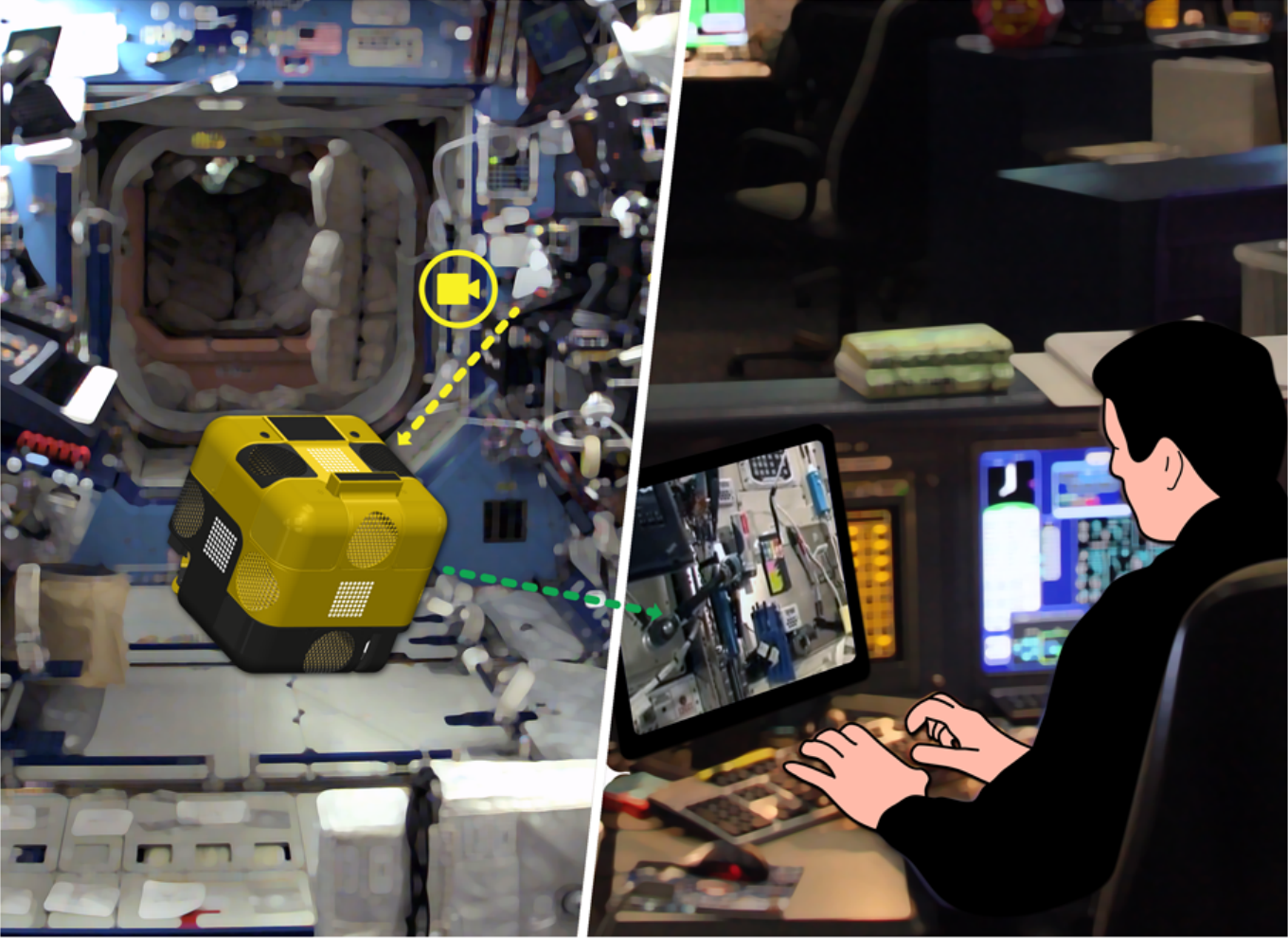

ISS Program, FOD, POIC





# Mobile Sensor Tasks

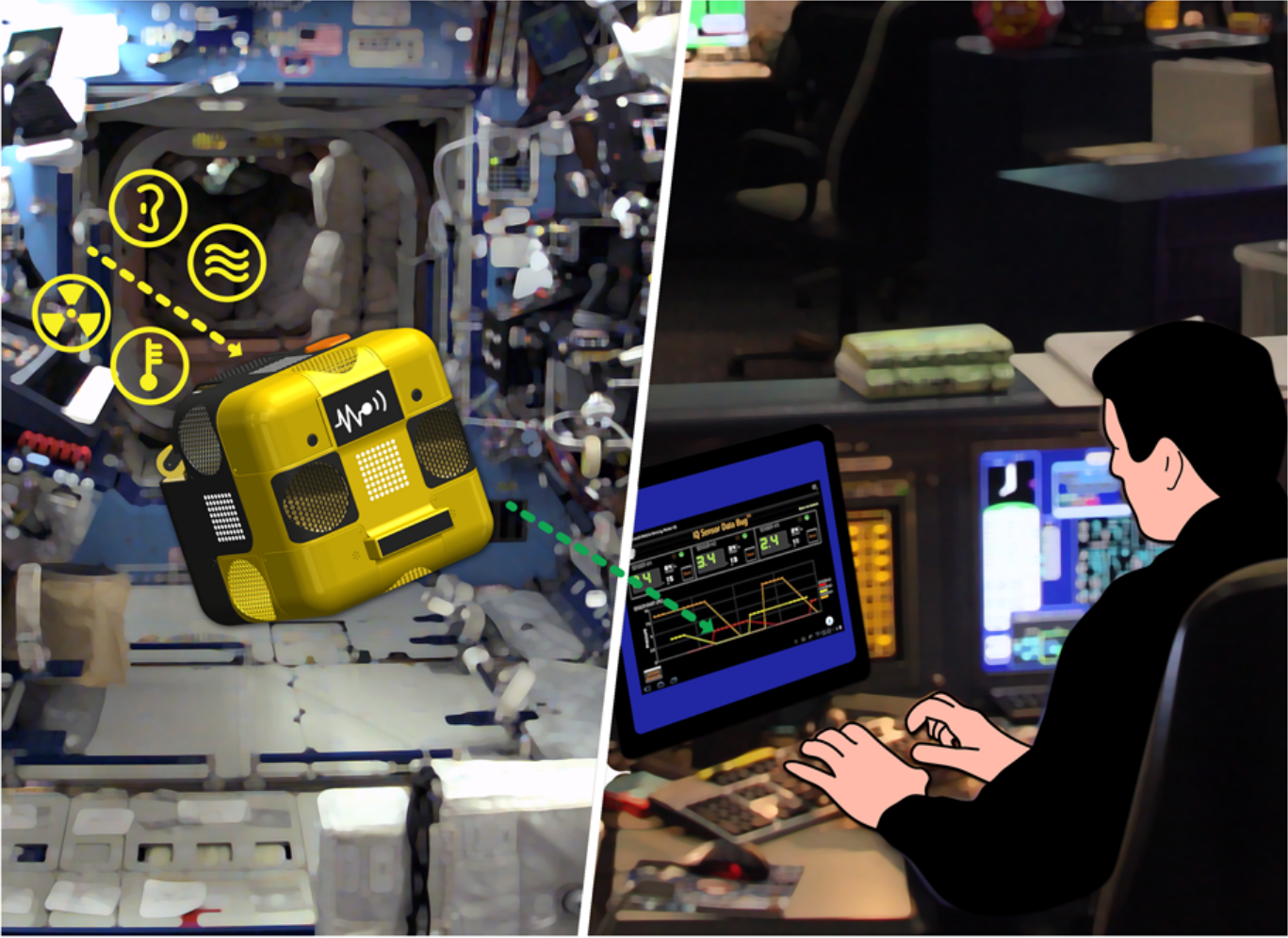

ISS Program, FOD, POIC



# Dock & Resupply





# System Architecture

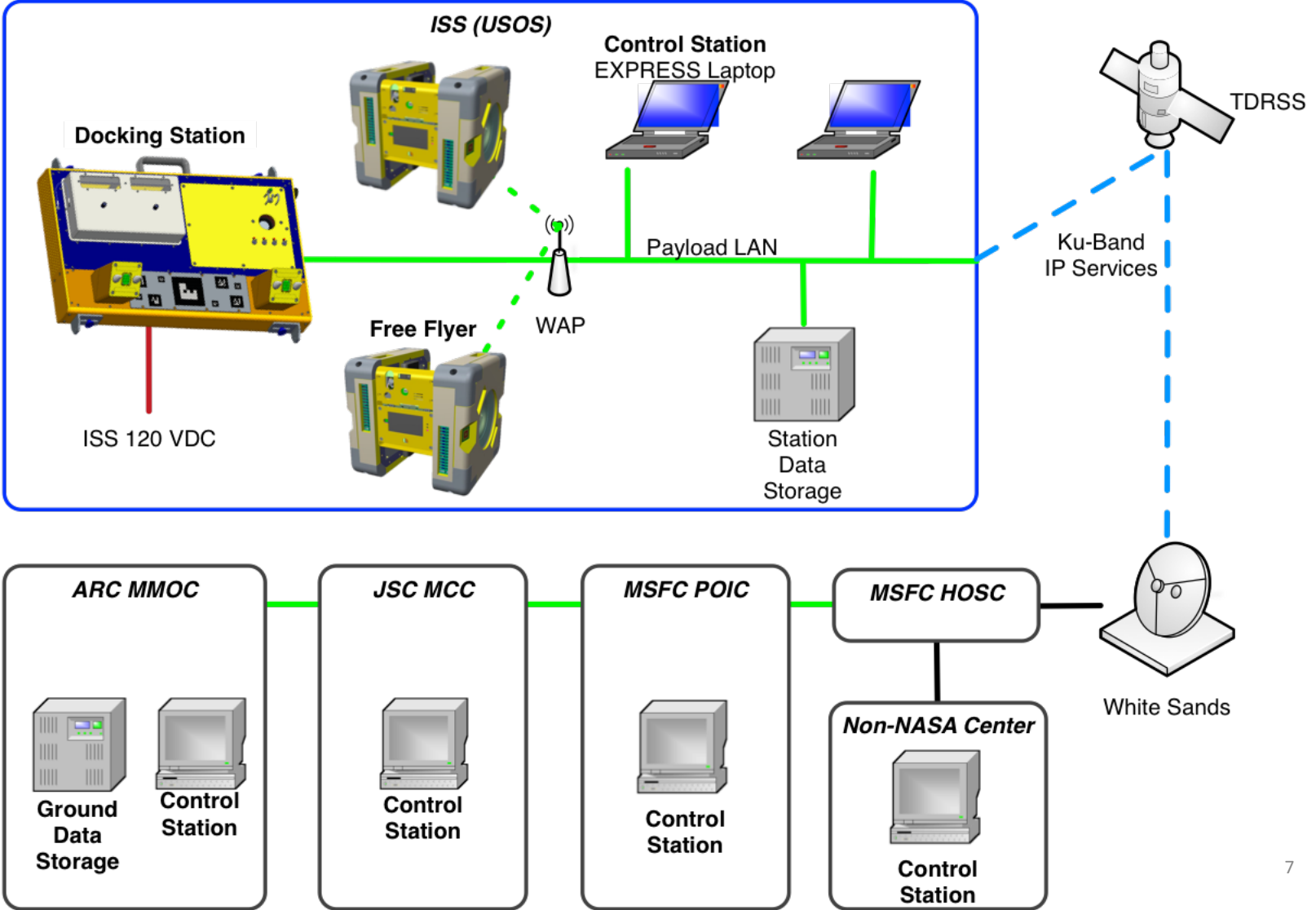



# Astrobee Free Flyer



Forward Top

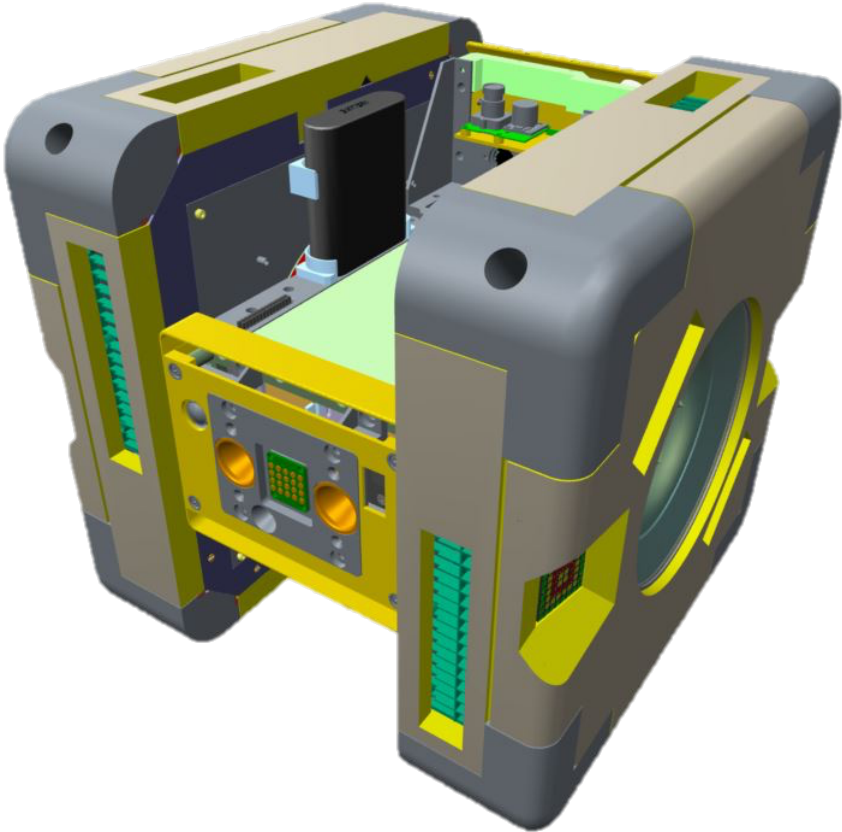

Aft Top





# External Sensors

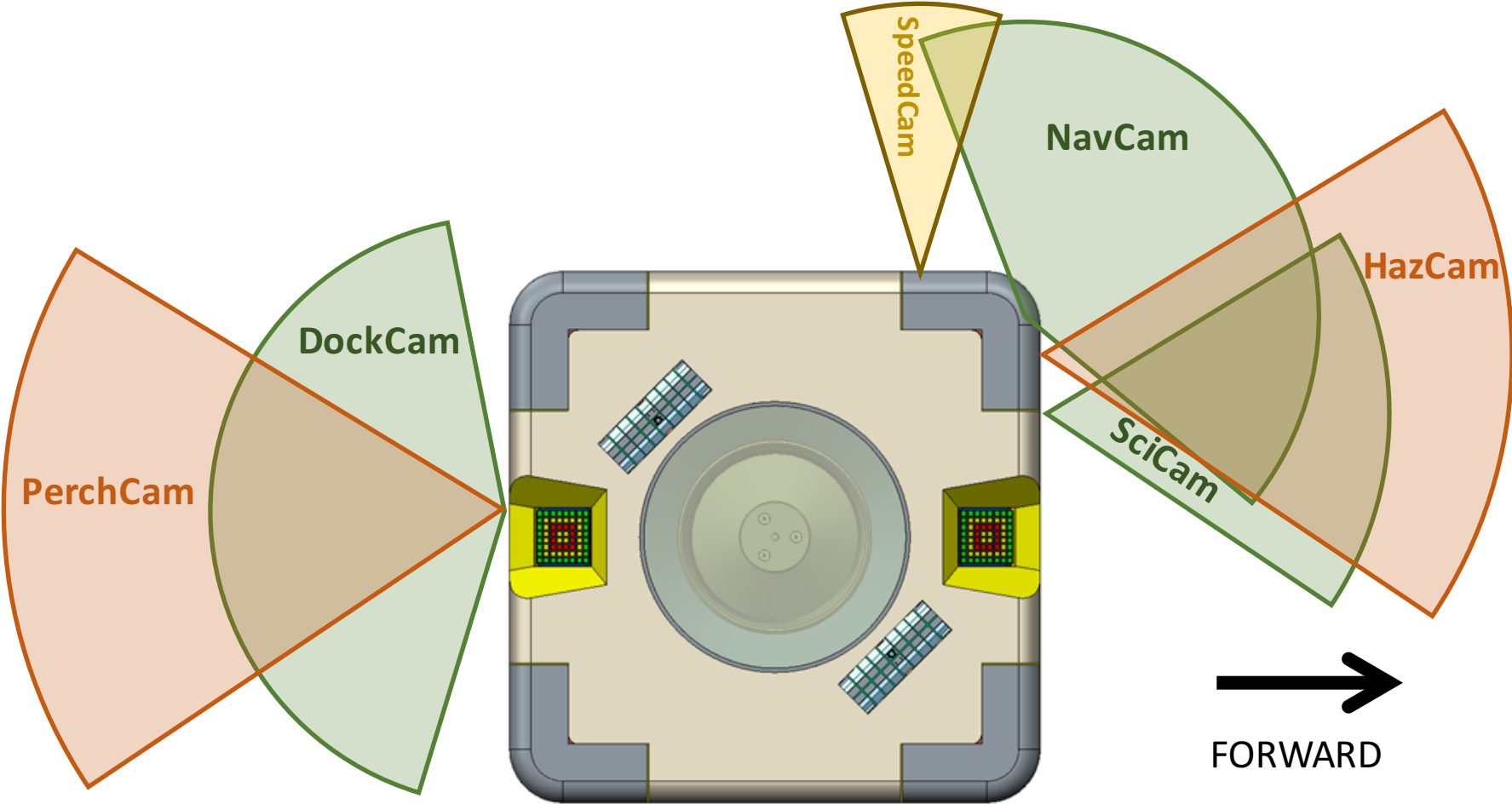

SIDE VIEW



# Payload Layout

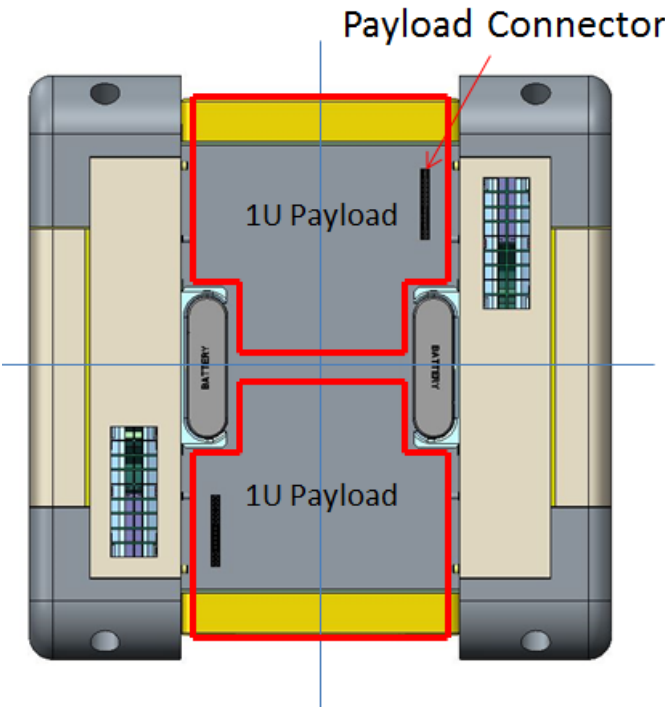

Bottom

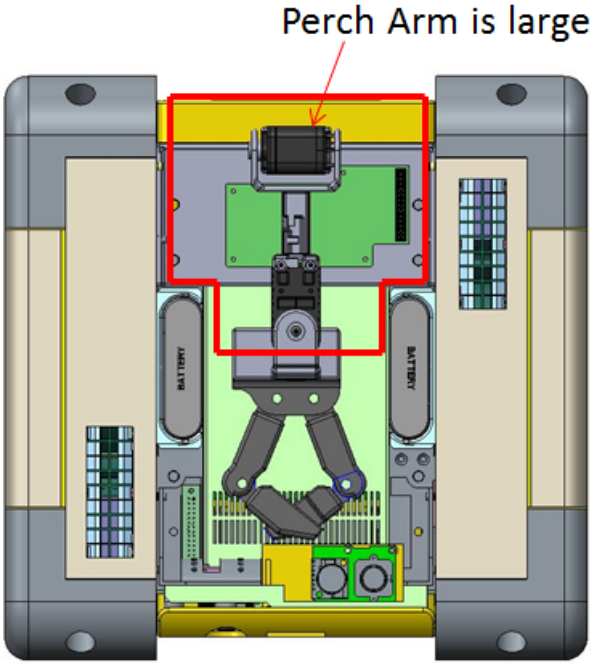

Top



# Perching Arm

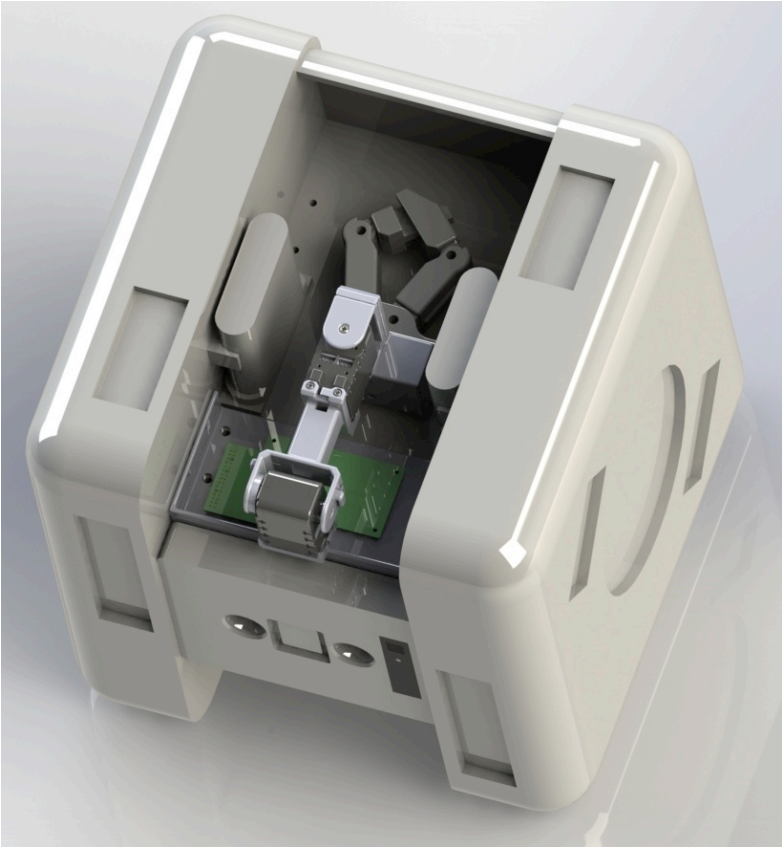

Stowed

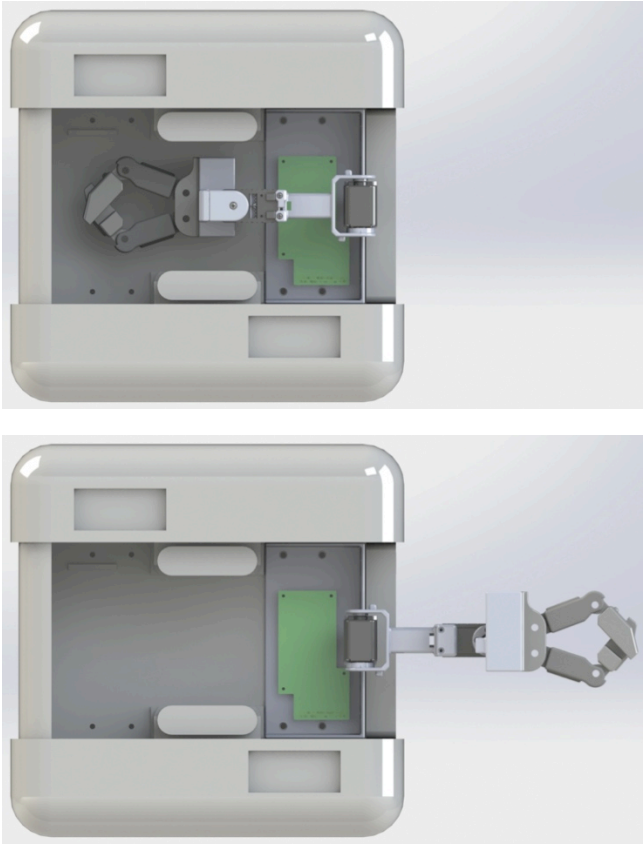

Stowed/Deployed



# Docking Station

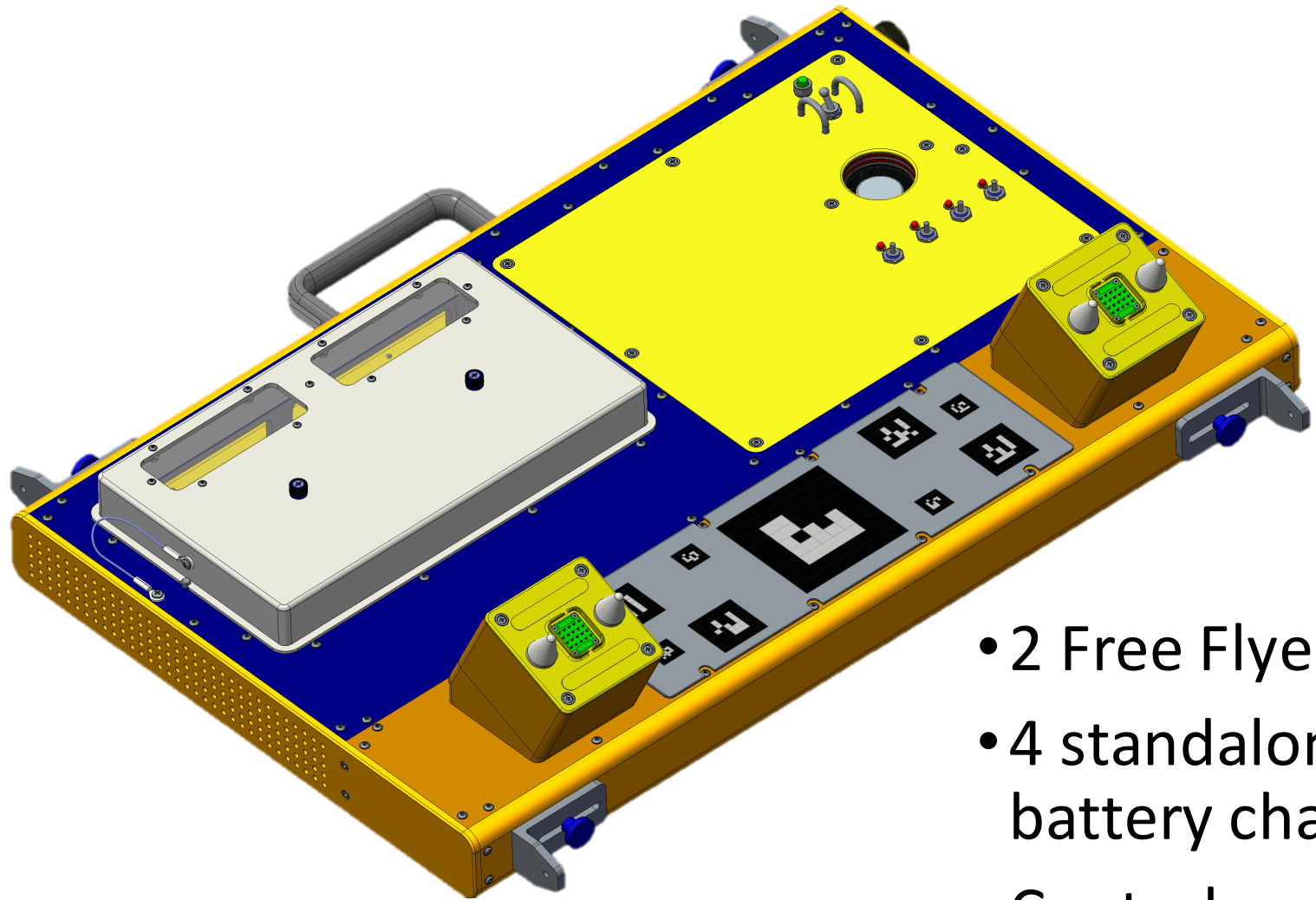

- 2 Free Flyer berths
- 4 standalone battery chargers
- Control panel





# Docking Station Front and Side View

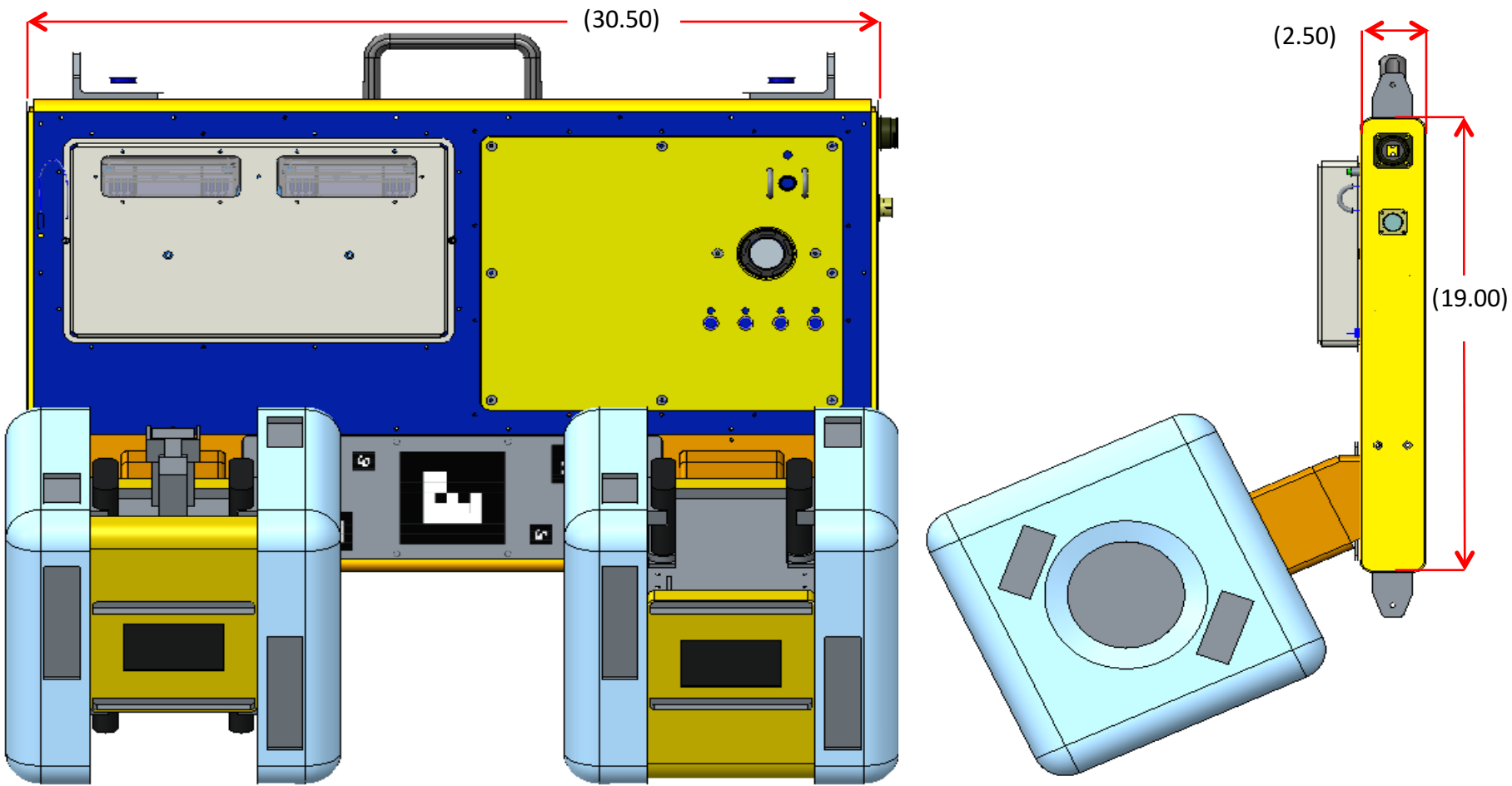

NOTE: Dimensions are in inches



# Control Station

- Eclipse based GUI
- Create, run, tele-op plans
- Run guest science
- Administration
- Separate ground UI for file transfer, software updates and diagnostics

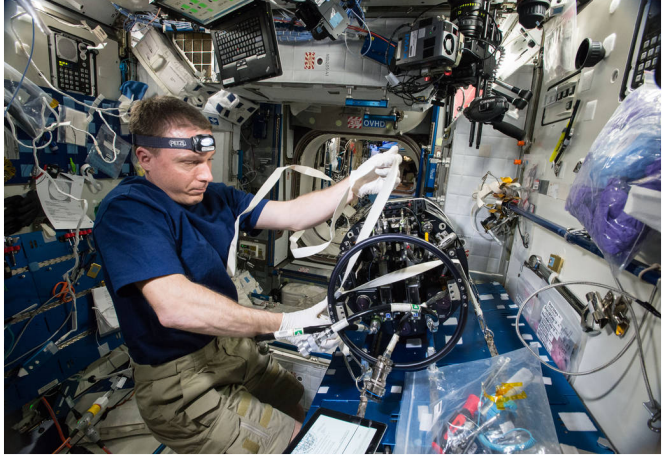

Distributed Video

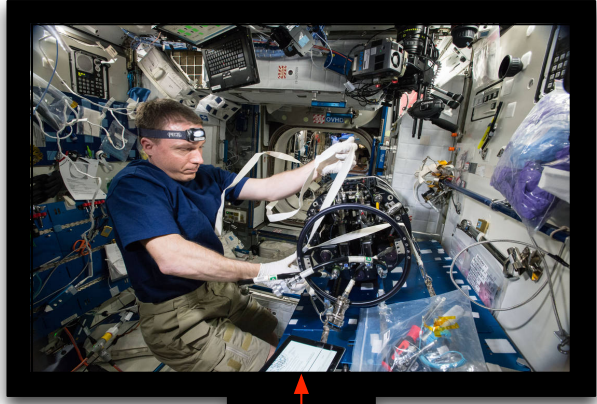
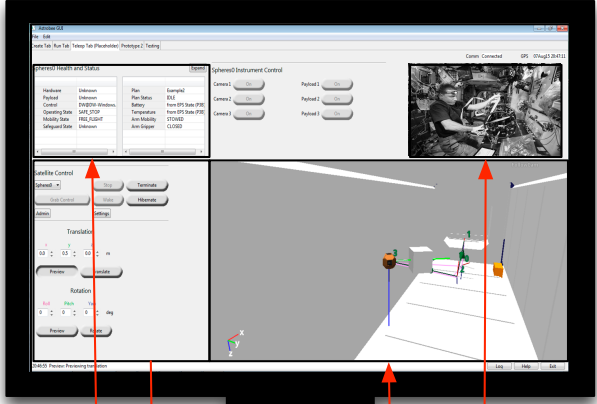

Robot Status Telemetry

Teleop Commands  
Nav & Plan Telemetry

Navcam Images @1Hz

Scicam Real-time HD Video



Full Real-time Stream



# Plan Validation

Plan Editor Run Plan Teleoperation Guest Science Advanced

Comm **Not Connected** GPS 01Jun16 23:00:39

Plan Editor

Plan Name AADemo  
Estimated Duration 00:11:02  
Validation Not Validated **Validate**

Plan Step	Duration
▼ AADemo	
0 Station	
0-1 Segment	00:01:23
1 Station	
1-2 Segment	00:01:44
2 Station	
<b>2-3 Segment</b>	<b>00:01:41</b>
3 Station	
3-4 Segment	00:02:41
4 Station	
4-5 Segment	00:02:20
5 Station	
5-6 Segment	00:01:13
6 Station	

**Add** **Delete** **Add via 3d View**

3 Station

Location Based **Coordinate Based** Bookmarks Commands

X 5.78 Y -0.19 Z -0 m  
Roll 0 Pitch 0 Yaw 0 deg

Ignore Orientation  
Tolerance 0.1 m  
 Drag to Translate  Drag to Rotate

Interactive Plan Viewer **Reset View**

**Validation Failed**  
Potential collision in Segment 2-3. Please move Station 2 or Station 3.  
**OK**

00:00:00 Message goes here

Log Help Exit



# Run Plan Tab

File Edit View Help  
 Plan Editor Run Plan Teleoperation

Comm Connected GPS 16Mav16 19:19:24

FreeFlyerA Health and Status Fault Details

Hardware	Nominal
Payload	Nominal
Software	Nominal
Control	Dw@dw-windows7-32
Operating State	Plan Execution
Mobility State	Free Flight
Safeguard State	-
Plan	Bb

Plan Step	Duration	Success
BB		
0 Station		Complete
0-1 Segment	00:01:14	Complete
1 Station		Complete
<b>1-2 Segment</b>		
2 Station		
2-3 Segment		
3 Station		
3-4 Segment		

rapid\_imagesensor\_sample-science

Image #164

Commands for: FreeFlyerA

Grab Control Terminate

Wake Hibernate

Plan Name Plan Valid

File ... C:\Users\DW\Document Upload

Run Stop

Pause Skip Step

Live Telemetry Reset View





# Teleoperation Tab

File Edit View Modeling Help  
Plan Editor Run Plan Teleoperation

Comm Connected GPS 22Apr16 20:30:52

FreeFlyerA Health and Status **Fault Details**

Hardware	Nominal
Payload	Nominal
Software	Nominal
Control	Dw@dw-windows7-32
Operating State	Safe Stop
Mobility State	Docked
Safeguard State	-
Plan	-

Instrument Control for: FreeFlyerA

Camera 1  Payload 1   
Camera 2  Payload 2   
Camera 3  Payload 3

Info Label



Commands for: FreeFlyerA

Translation Rotation Arm Commands

AFT  FWD  
PORT  STBD  
OVHD  DECK  
m

Show Preview

Live Telemetry

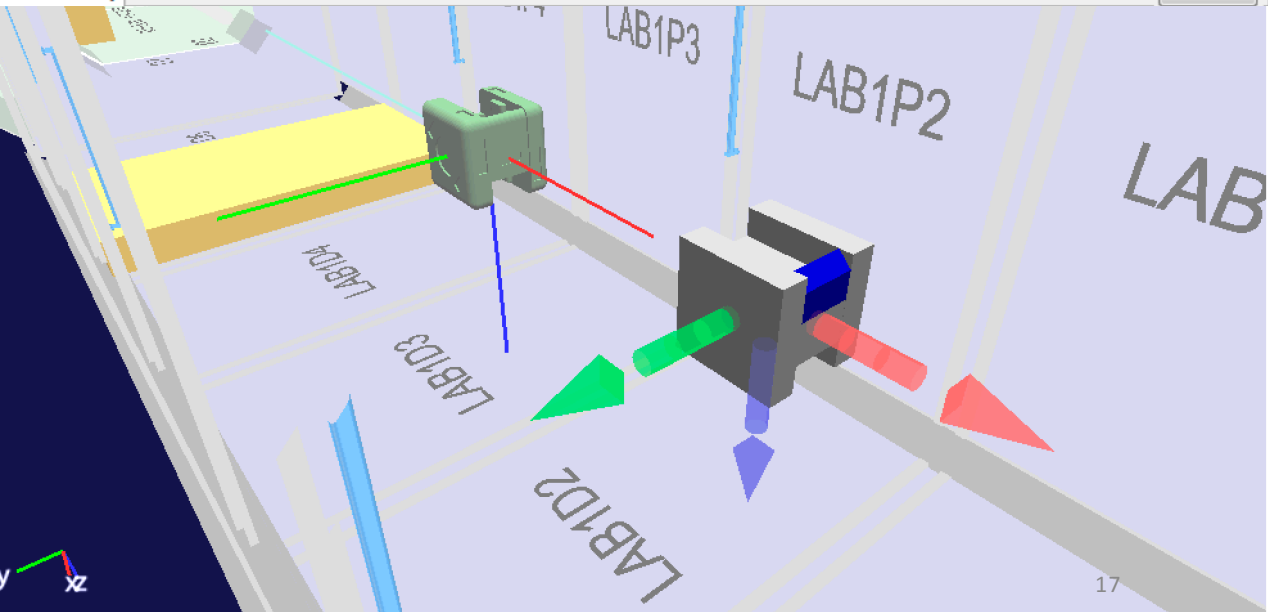

20:30:11 FreeFlyerA: Completed



# Navigation Demonstration

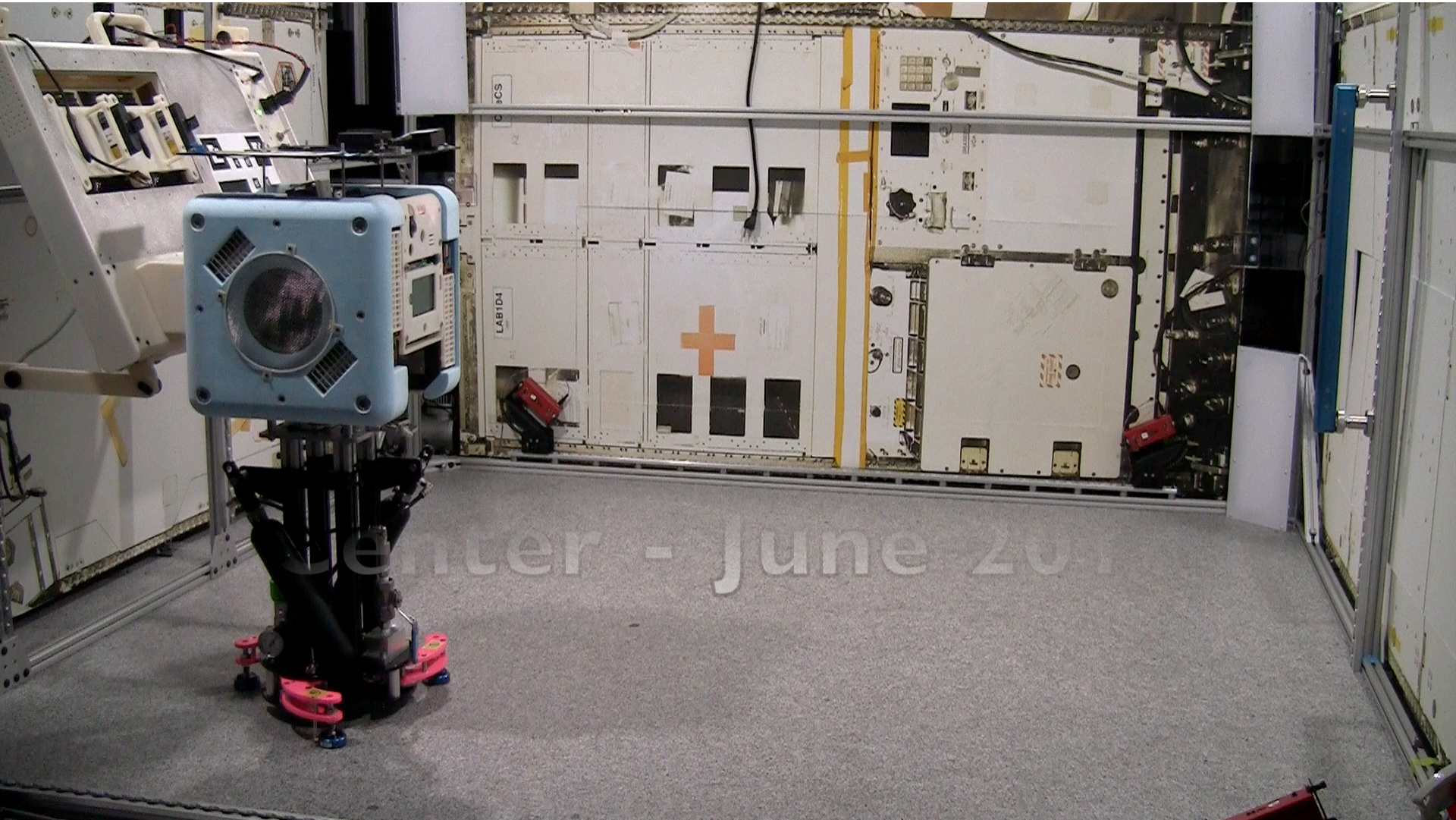

Center - June 2011





# Perching Arm Demonstration

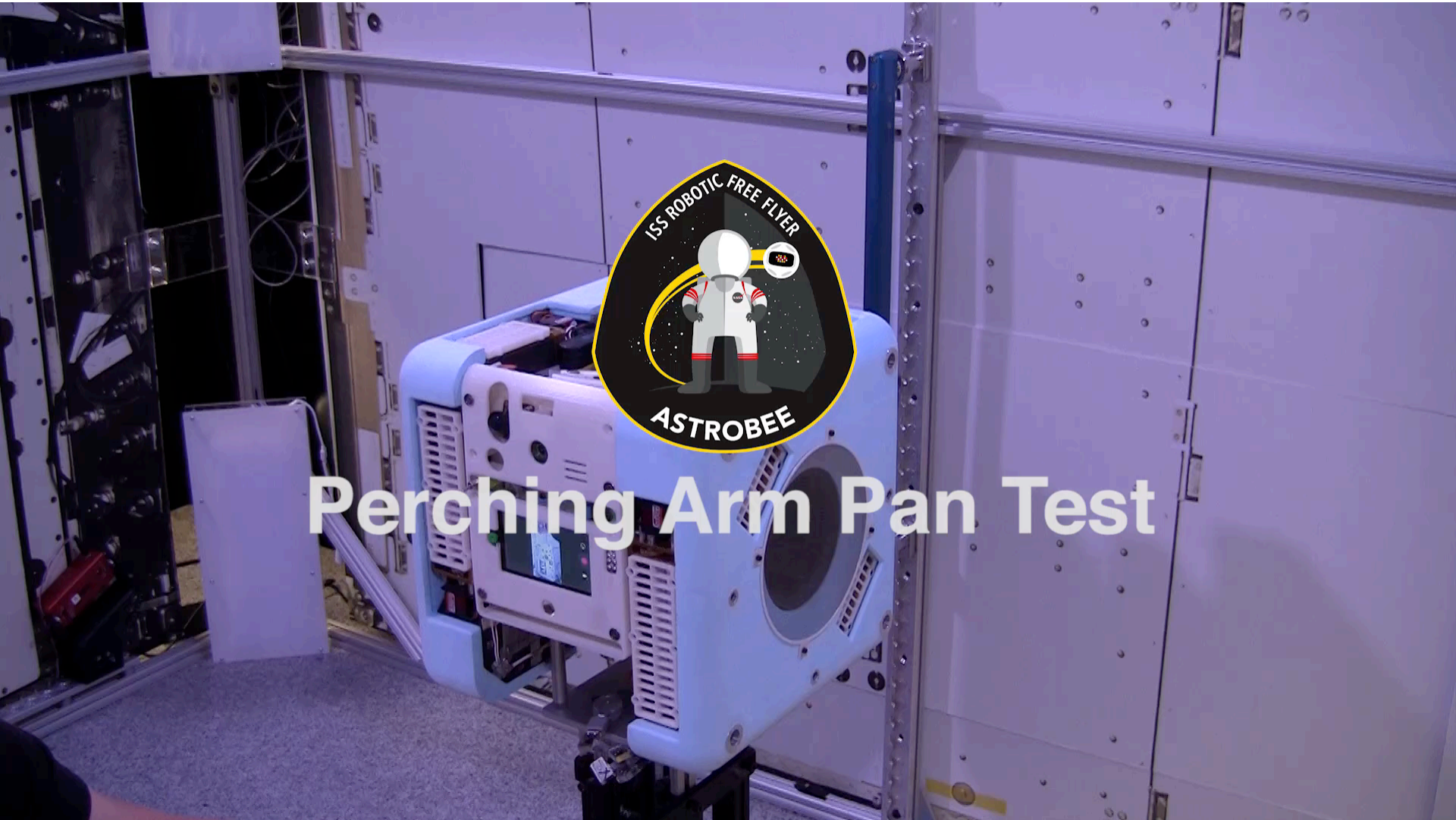

## Perching Arm Pan Test



# Backup





# Base Layout

PerchCam DockCam

Battery  
(1 on top +  
1 on bottom)

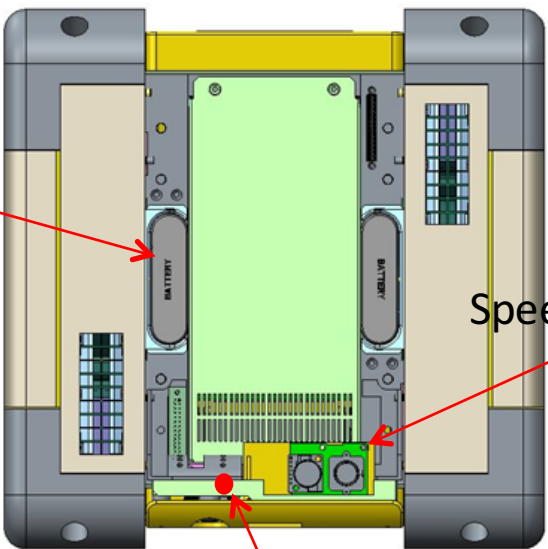

SpeedCam

Terminate Button

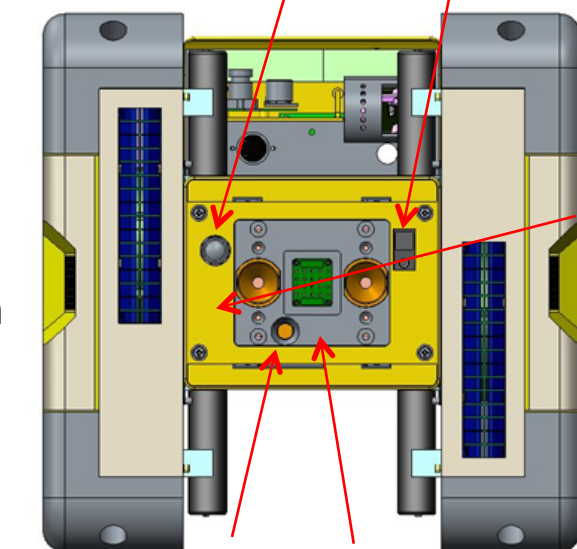

Status LEDs

Aft LED Light Dock Adapter

HazCam  
NavCam

SciCam  
Laser

Microphone /  
Speaker

Touch Screen /  
Touch Screen Activate Button

Status LEDs  
Front LED light

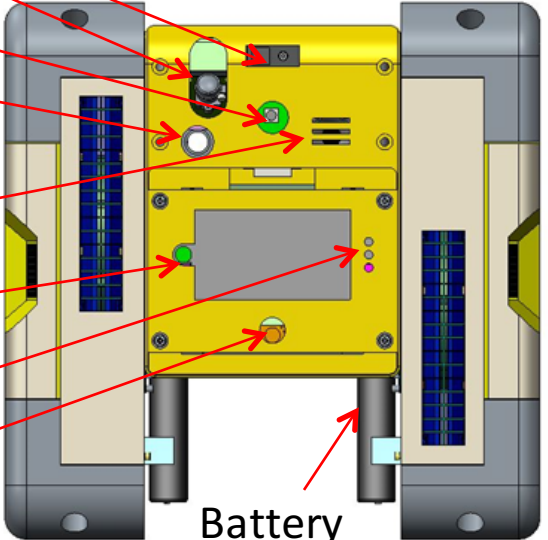

Battery

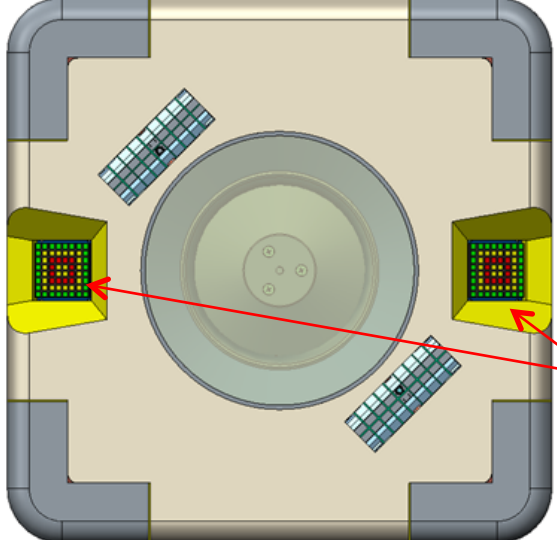

LED  
Indicators



# Indicators

- Touch Screen Activate Button
- Wake Button (illuminated green when awake)
- Power Switch (illuminated green when power is on)

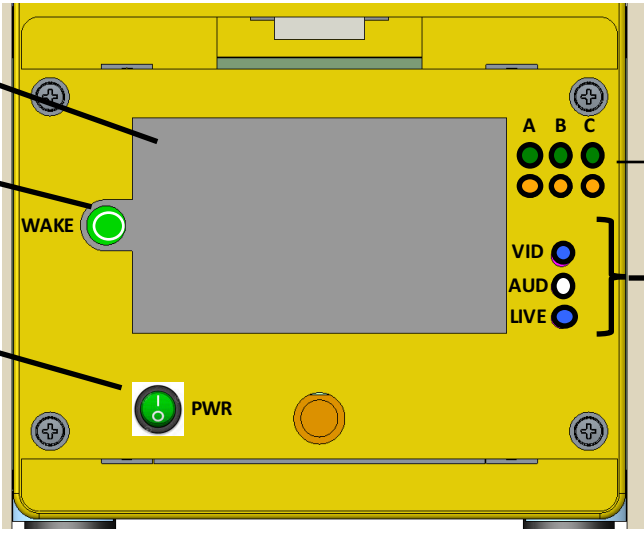

- General Status LEDs (crew can call down status in case of errors, like "A is green, B is amber, C is off")
- A/V Mode LEDs (blue, white, blue)

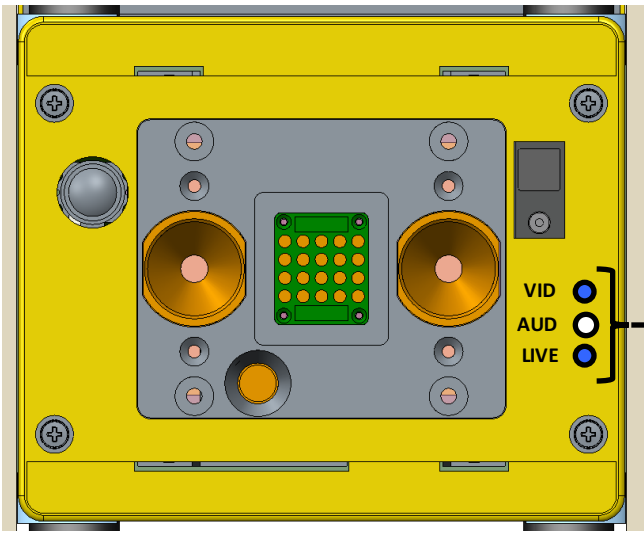

- A/V Mode LEDs (blue, white, blue)