

# Design and Development of a 200-kW Turbo-electric Distributed Propulsion Testbed

Kurt V. Papathakis<sup>1</sup>, Kurt J. Kloesel, P.E.<sup>2</sup>, Yohan Lin<sup>3</sup>, Sean Clarke, P.E.<sup>4</sup>, Jacob J. Ediger<sup>5</sup>, and Starr Ginn<sup>6</sup>  
*NASA Armstrong Flight Research Center, Edwards, California, 93523*

The National Aeronautics and Space Administration (NASA) Armstrong Flight Research Center (AFRC) (Edwards, California) is developing a Hybrid-Electric Integrated Systems Testbed (HEIST) Testbed as part of the HEIST Project, to study power management and transition complexities, modular architectures, and flight control laws for turbo-electric distributed propulsion technologies using representative hardware and piloted simulations. Capabilities are being developed to assess the flight readiness of hybrid electric and distributed electric vehicle architectures. Additionally, NASA will leverage experience gained and assets developed from HEIST to assist in flight-test proposal development, flight-test vehicle design, and evaluation of hybrid electric and distributed electric concept vehicles for flight safety. The HEIST test equipment will include three trailers supporting a distributed electric propulsion wing, a battery system and turbogenerator, dynamometers, and supporting power and communication infrastructure, all connected to the AFRC Core simulation. Plans call for 18 high performance electric motors that will be powered by batteries and the turbogenerator, and commanded by a piloted simulation. Flight control algorithms will be developed on the turbo-electric distributed propulsion system.

## Nomenclature

ARMD	=	Aeronautics Research Mission Directorate
Batt	=	battery
BMS	=	battery management system
CIS	=	cockpit interface system
COTS	=	commercial off-the-shelf
DAQ	=	data acquisition
Dyno contr.	=	dynamometer controller
EMI	=	electromagnetic interference
GEN	=	generator
HEIST	=	Hybrid-Electric Integrated Systems Testbed
HEP	=	hybrid electric propulsion
HIL	=	Hardware-In-the-Loop
HIU	=	hardware interface unit
IADS	=	Inter Active Display System
LEAPTech	=	Leading Edge Asynchronous Propulsion Technology
MCI	=	motor controller inverter
NASA	=	National Aeronautics and Space Administration
NPSS	=	Numerical Propulsion System Simulation
PAI	=	propulsion-airframe integration
PWM	=	Pulse-Width Modulated
SES	=	Simulation Electric Stick

---

<sup>1</sup> HEIST Power Architecture, Vehicle Integration & Test Branch, PO Box 273/MS4840D, member.

<sup>2</sup> HEIST IronBird Principal Investigator, Aerodynamics & Propulsion Branch, PO Box 273/MS4800, non-member.

<sup>3</sup> HEIST Test and Verification, Vehicle Integration & Test Branch, PO Box 273/MS4800, non-member.

<sup>4</sup> HEIST LEAPTech Principal Investigator, Systems Development Branch, PO Box 273/MS4840D, non-member.

<sup>5</sup> HEIST Propulsion Systems Researcher, Aerodynamics & Propulsion Branch, PO Box 273/MS4840D, non-member.

<sup>6</sup> Deputy Aeronautics Research Director, Research Directorate, PO Box 273/MS4800, member.

SIM = simulation computer  
TeDP = turbo-electric distributed propulsion

## I. Introduction

AIRCRAFT emissions could result in as many as 43 gigatonnes of CO<sub>2</sub> by the year 2050.<sup>1</sup> Reducing energy consumption and emissions for aircraft aligns with the strategic thrusts of the NASA Aerodynamics Research Mission Directorate (ARMD).<sup>2</sup> Investigation into new technologies capable of achieving transformative change in these areas has led to hybrid gas-electric propulsion systems, which utilize the fuel savings and reduced emission benefits of electric motors, generators, and batteries, while maintaining the specific power of hydrocarbon-only engines. While new “all-electric” propulsion technologies are opening design possibilities for future flight, current technology levels limit the usefulness of these systems as a sole means of propulsion, especially for larger aircraft. Hybrid gas-electric systems are believed to provide a meaningful middle ground, providing the power and thrust required from the engine while maintaining the energy consumption and emissions benefits of the electric systems. Strategic Objective 2.1 of the 2015 NASA Armstrong Strategic Plan is to “explore and develop efficient air transportation systems technologies and bring them to flight.”<sup>3</sup>

The NASA is dedicated to developing hybrid electric propulsion technologies as a means of reducing energy consumption and emissions for aircraft. There are a few NASA-funded electric and hybrid electric projects from different NASA Centers, including the NASA Armstrong Flight Research Center (AFRC) (Edwards, California). Each project identifies a specific technology gap that is currently inhibiting the growth and proliferation of relevant technologies in commercial aviation. This paper describes the design and development of a turbo-electric distributed propulsion (TeDP) hardware-in-the-loop (HIL) simulation bench, which is a testbed for discovering turbo-electric control, distributed electric control, power management control, and integration competencies while providing risk mitigation for future turbo-electric flying demonstrators. The Hybrid-Electric Integrated Systems Testbed (HEIST) Project is the research effort developed at AFRC for studying the integration challenges associated with complex electric and hybrid electric propulsion systems, including efforts associated with distributed electric propulsion (DEP). Some of the research objectives include testing different power bus architectures and different power sources, investigating subsystem integration, power, and mechanical system transients; exploring electromagnetic interference (EMI) and thermal challenges; and relating these investigations back to flight controls research. The AFRC has demonstrated a core competency in bringing new technologies to flight through the use of ground-based test beds, simulation, verification, and validation processes.

The HEIST Project represents a vital rung in the NASA ARMD development strategy for two of the six 2015 strategic thrusts: Strategic Thrust 3, “Ultra-Efficient Commercial Vehicles,” and Strategic Thrust 4, “Transition to Low-Carbon Propulsion.”<sup>2</sup> The HEIST research and integration directly applies to Strategic Thrust 4, providing meaningful improvements for fuel efficiency and reduction in emissions for aircraft propulsion. Improvements and lessons learned will be applied to future NASA ARMD projects, with each project providing another piece of the larger jigsaw puzzle: each project improves the current state-of-the-art technologies, integration strategies, and controls research. The HEIST Project will provide valuable input toward the development of a 1-2 MW demonstrator X-plane demonstrator, which will utilize the turbo-electric architecture and lessons learned from HEIST to further advance green aviation, contributing to Strategic Thrust 3. The HEIST Project is funded by the Advanced Air Transport Technologies (AATT) Project under the Advanced Air Vehicles Program (AAVP) of the NASA ARMD.

The HEIST Testbed, as part of the HEIST Project, provides NASA with systems integration strategies and a platform to perform complex flight controls research on the path to a turbo-electric flight demonstrator. The first HEIST experiment, the Leading Edge Asynchronous Propeller Technology (LEAPTech), researched the low-speed aerodynamics and high lift effects associated with tightly coupling the distributed electric propulsion system with aerodynamic lifting surfaces. The primary benefit of the LEAPTech configuration was integration and testing of a high power electric propulsion system including command, instrumentation, and EMI protection design and analysis. This first experiment configuration was fully electric, limiting the applicability for larger commercial aircraft applications, which the second HEIST experiment (HEIST Testbed) is designed to address on a reduced scale.

Hardware-in-the-loop simulation testbeds have been used at AFRC since the 1960s. The HILs consist of flight avionics, actuators, hydraulic systems, power generators, flight control computers, research hardware, and wire harnesses representative of an aircraft that is linked to a six-degree-of-freedom (DOF) simulation computer. These representative aircraft are sometimes referred to as “iron birds,” because they consist of representative equipment of a vehicle, sometimes with partial airframe and control surfaces. Iron birds are used to characterize or stress-test systems on the ground, in order to identify and solve problems prior to a flight-test campaign.<sup>4,5,6</sup> There are many advantages of using iron birds as compared to all digital simulations, including:

- 1) understanding vehicle level effects and behavior when software or hardware configurations updates occur (that is, new flight control gain improvements or addition of a research control computer);
- 2) determining system latencies that may affect vehicle, system, or subsystem performance;
- 3) verifying voting logic implementation for flight control redundancy management;
- 4) characterizing system upgrades, such as conversion of hydraulic actuators to electric actuators;
- 5) testing actuator rate and frequency response for modeling high-fidelity actuator models;
- 6) stressing system and subsystem interactions;
- 7) checking new flight mission maneuvers;
- 8) training pilots and providing cockpit upgrade familiarization;
- 9) evaluating simulated vehicle stability and handling qualities;
- 10) quantifying electromagnetic compatibility or EMI;
- 11) fine-tuning algorithms or test procedures;
- 12) identifying thermal, acoustic, volumetric, or other physical limitations;
- 13) exploring envelope expansion limitations;
- 14) performing failure modes and effects testing; and
- 15) demonstrating new vehicle capabilities.

The simulation computer is typically configured with an interface device that handles, monitors, and records all sensor and communication data between the vehicle hardware and the simulation. The interface device also acts as a switch, so that a user can select to test the real system or use a model that is running in real time within the simulation computer. A representative cockpit is typically configured with the iron bird to provide the pilot interface. The avionics displays, stick, and cockpit switches provide the same look, feel, and layout as the real vehicle to maximize training and testing efficiency, reflecting the “Test like you fly” philosophy. The HEIST Testbed lends itself to the investigation of novel flight controls research, EMI and thermal characterization, power management, and transition challenges early on, so that design considerations and requirements can be formulated for the next-generation, low-carbon X-plane.

The ultimate goal is to bring about transformative change to commercial aviation, meaning significant improvement in energy consumption and emissions for large-scale commercial aircraft. Improvements in battery, motor, bus architecture, harnesses, and other technologies are needed to realize this goal. Figure 1, from Ref. 7, shows how the current state-of-the-art technologies are driving innovation toward a large-scale commercial vehicle, indicated by the star in the upper right-hand area of the figure. The horizontal axis represents knowledge through integration and demonstration; the vertical axis represents environmental benefits. The objectives will coalesce, with each system and demonstration more intricate and more representative than the previous, until large-scale transformative flight demonstration can be achieved.

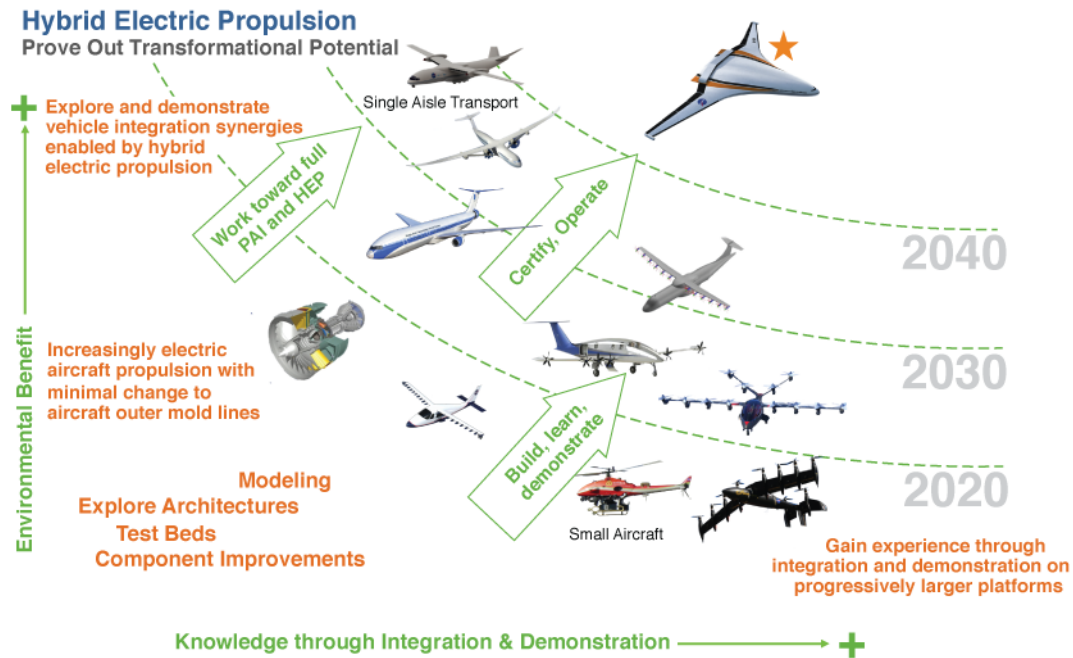

Figure 1. National Aeronautics and Space Administration hybrid electric propulsion spiral development.<sup>7</sup>

## II. HEIST Project Description and HEIST Testbed Objectives

The following sections describes the three HEIST Project experiments and the objectives of the HEIST Testbed experiment.

### A. Description of the HEIST Project

The HEIST Project consists of three experiments, each providing a unique capability for improving hybrid electric distributed propulsion systems design, integration, and control at AFRC. The LEAPTech was the first experiment of the HEIST Project, exploring the aero-propulsive interactions and high lift capability of a distributed electric propulsion system. The second experiment will utilize the LEAPTech wing as the HEIST Testbed. A third, smaller-scale, experiment called Mini-HEIST will seek to couple small-scale drive and brake motors to better understand the controllability of these electric motors for the larger dynamometer development expected during later phases of the HEIST Testbed.

The LEAPTech experiment utilized a distributed propulsion wing with 18 motor/propeller (“propulsor”) assemblies oriented on the leading edge, a retrofitted water truck, an articulated support structure, a battery system, an instrumentation system, and a CANBus communication network. Figure 2 shows LEAPTech testing at AFRC.

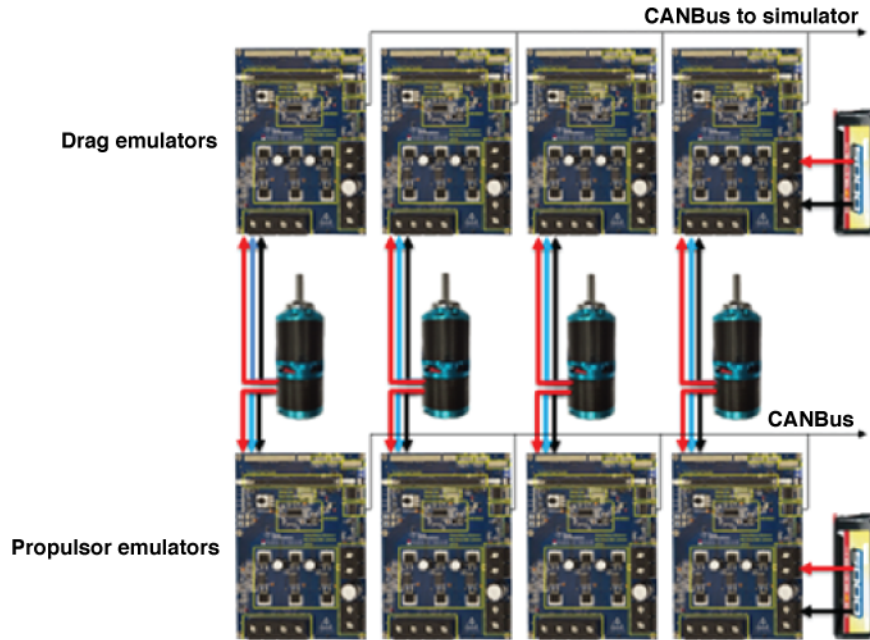

**Figure 2. LEAPTech testing at AFRC.**

The LEAPTech experiment analyzed slow-speed aerodynamics of a high-lift, distributed electric propulsion system. The battery consisted of six large battery packs producing a total power greater than 200 kW with a bus voltage of approximately 100 VDC. Contactor relays were installed to allow the co-pilot (passenger) of the truck to manually engage each motor group. A total of seven load cells were used to measure the forces (lift, drag, and side force) and moments (pitch, roll, and yaw). During testing, the co-pilot provided motor commands and monitored motor and controller temperatures and load cells for operational limits. The wing used on the LEAPTech experiment was later removed from the truck and is planned to be used in a stationary fixture for future HEIST experiments.

The LEAPTech power and communication network was the starting point for the hardware integration approach. The power bus was 100 VDC and the command and communications network was over the CANBus. The objective of the LEAPTech experiment was to validate low-speed computational fluid dynamics (CFD) and develop systems integration capabilities for distributed electric propulsion. The primary focus of the LEAPTech testing was to capture the aerodynamic performance of a distributed electric propulsion system on the leading edge of a wing at low speed. System integration, testing strategies, concept of operations, and relationships with vendors were secondary benefits to the experimentation. While LEAPTech had numerous systems integration challenges, ultimately the focus was the aerodynamic data.

The Mini-HEIST experiment was formulated to provide a smaller-scale hardware tool for initial integration and controls development during the assembly and testing of the HEIST Testbed hardware. Lessons learned and controls algorithms will be applied to the HEIST Testbed once the system is operational and connected to the AFRC Core simulation. During the HEIST Testbed buildup, it will be necessary to conduct basic controls systems modeling, algorithm development, and intermediate hardware interface testing using the separate, smaller Mini-HEIST (shown in Fig. 3). The small scale allows rapid hardware buildup. The Mini-HEIST hardware concept was based on the Propulsion Electric Grid Simulator (PEGS) by B. B. Choi<sup>8</sup> at the NASA Glenn Research Center (Cleveland, Ohio) with several functional changes and enhancements, including directly shaft-coupling two electric motors for faster hardware development. Two counter-rotation motors are coupled together on a single shaft to reduce the machining time spent aligning two shafts.



**Figure 3. Mini-HEIST system architecture.**

Ultimately, Mini-HEIST serves as a useful first step in developing motor control and system integration strategies for the larger HEIST systems, and specifically the development of the dynamometer system as stated below.

The HEIST Testbed will utilize the distributed electric propulsion wing from the LEAPTech experiment and control law and integration strategies from Mini-HEIST. The HEIST Testbed will provide a hybrid electric capability by paring the distributed electric system from LEAPTech with a turbogenerator to create a TeDP testbed. Four of the electric motor / controller pairs and the power harness on the distributed electric propulsion wing will be swapped with dynamometers. The dynamometers will enable representative aerodynamic loads to be applied to the distributed electric propulsion system, increasing control algorithm development fidelity and systems testing.

### **B. Objectives of the HEIST Testbed**

The HEIST Testbed has three goals for the HEIST Project. The HEIST Testbed experiment aims first to develop a TeDP testbed to study power management and transition complexities, modular architectures, and flight control laws for hybrid distributed propulsion technologies using subscale hardware and piloted simulations to reduce the risk for scaling to transport class. Second, the experiment aims to develop additional capabilities and understanding to assess the flight readiness of hybrid electric / distributed electric flight-test activities and safely carry out flight-test activities. The third and final goal of the HEIST Testbed is to leverage the experience gained and assets developed (simulation and bench) to assist NASA in flight-test proposal and requirements development, flight-test vehicle design, evaluation of hybrid electric / distributed electric concept aircraft and flight-test support.

In order to address these stated goals, several objectives were developed, the major ones are shown in Table 1.

**Table 1. HEIST Project objectives.**

Objective		Objective description
1	Develop HIL testbed and control algorithms scalable to 1-2 MW	Extrapolate from kW to MW level - quantifies scalability and reduces programmatic risk
2	Test HEIST Testbed in flight-like manner with piloted simulation	Identify issues and shortcomings of HEIST Testbed power system during real-world scenarios
3	Improve flight control requirements for large benches	Provide inputs to larger-scale bench efforts and future flight-test efforts
4	Evaluate degradation effects and failure modes of HEP system	Quantify performance degradation from HIL environment and assess severity of hazards for HEP
5	Investigate hybrid power management	Investigate multiple solutions to control command, optimize power management over vehicle performance
6	Provide testbed to explore different bus architectures	Need hardware testbed to provide informed decisions for hybrid aircraft applications
7	Develop HEP design, fabrication, test experience, and lessons learned	Reduce risk, improve safety, and increase capability for future 1-2 MW flight demonstrator activities
8	Formulate and drive new design trades using HEP test data	Answer TeDP design considerations by using an HIL testbed
9	Investigate and develop flight maneuvers for TeDP systems	Improve climb, descent, and other maneuver schedules for TeDP operations

Development and test experience from other experiments within the HEIST Project will be leveraged. Hardware, including the distributed electric propulsion wing, testing experience, and lessons learned are leveraged from the LEAPTech experiment. Experience from Mini-HEIST will help improve motor control and simulation development of the test bench, specifically the development of the dynamometer system, which is planned to be integrated into HEIST in later phases.

### **III. HEIST Testbed Architecture and Phased Development Approach**

The HEIST Testbed architecture consists of a distributed electric propulsion wing (including propellers, motors, controllers, and cable harnesses), batteries, turbogenerator, dynamometers, simulation computers, flight control computers, and cockpit. The fact that this testbed will include high-speed, legacy propellers from the LEAPTech project (approximately 7000 rpm), and a turbine engine requires testing outdoors due to hangar emission restrictions and the hazards inherent to high-speed propellers. The simulation computers, cockpits, and SCRAMNet (Curtiss-Wright Corporation, Ashburn, Virginia) infrastructure are located on the second floor of a hangar test bay at AFRC. These factors necessitate mobility of the wing and turbogenerator, in order to be housed in a hangar environment but be able test outside. This mobility requirement led to the decision to put all mobile hardware on trailers; investigations into the concept of operations led to a three-trailer setup. The trailer layout and relation to simulator / flight control computer/cockpit is shown in Fig. 4.

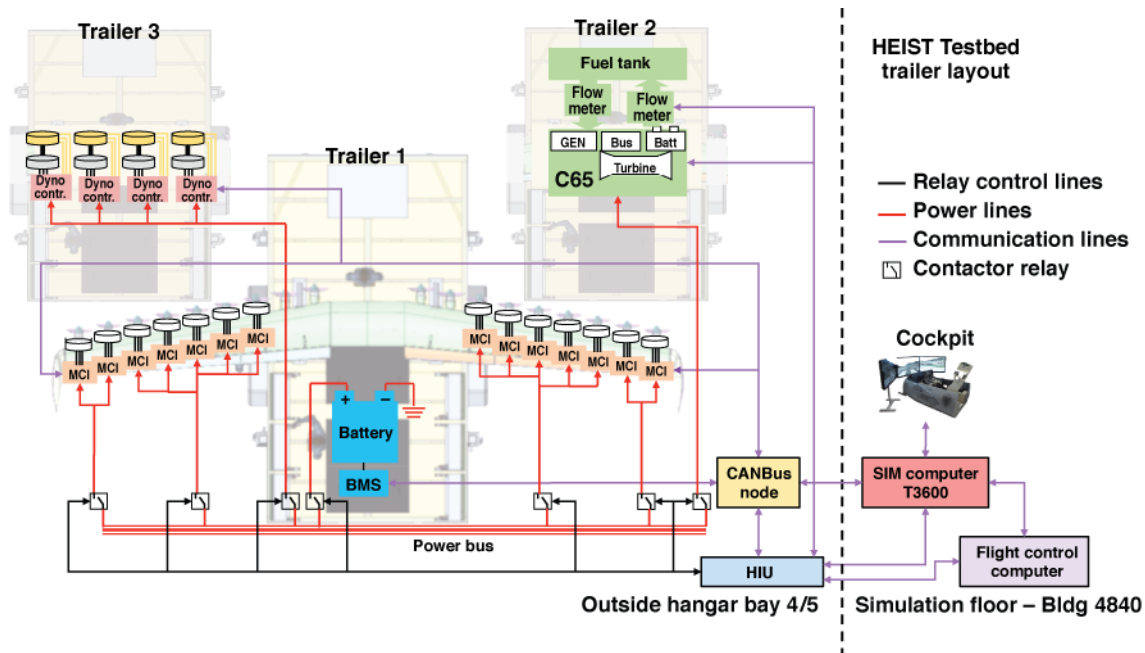

**Figure 4. HEIST system architecture.**

Trailer 1 will carry the wing (including the JM1 motors [Joby Motors, Santa Cruz, California]; motor controllers; power; and CANBus harnesses); battery; battery management system (BMS); AC/DC converter (not shown); and seven contactor relays. Trailer 2 will carry the Capstone C65 (Capstone Turbine Corporation, Chatsworth, California) turbogenerator (which includes turbine, starter battery, generator, switching hardware, and bus harnesses), fuel tank, flow meters, and plumbing. Trailer 3 will carry the dynamometers which physically swap any four propeller / motor / controller assemblies and harnesses (shown as the four middle propeller / motor / controller assemblies). The hardware interface unit (HIU) and CANBus node will route the communication lines, contactor relay signals, turbogenerator commands, BMS protocols, and dynamometer commands between the three trailers and the control room on the simulator floor. The cockpit, simulation computer, and flight control computer will simulate a turbo-electric distributed propulsion airplane and interfaces with flight-representative hardware.

#### **A. HEIST Project Phase Development and Hardware Buildup Approach**

The development and fabrication of the HEIST Testbed is divided into three phases, allowing the researchers ample testing and verification of each subsystem for full system buildup. Figure 5 depicts the phased approach and how the LEAPTech and Mini-HEIST experiments affect HEIST Testbed development.



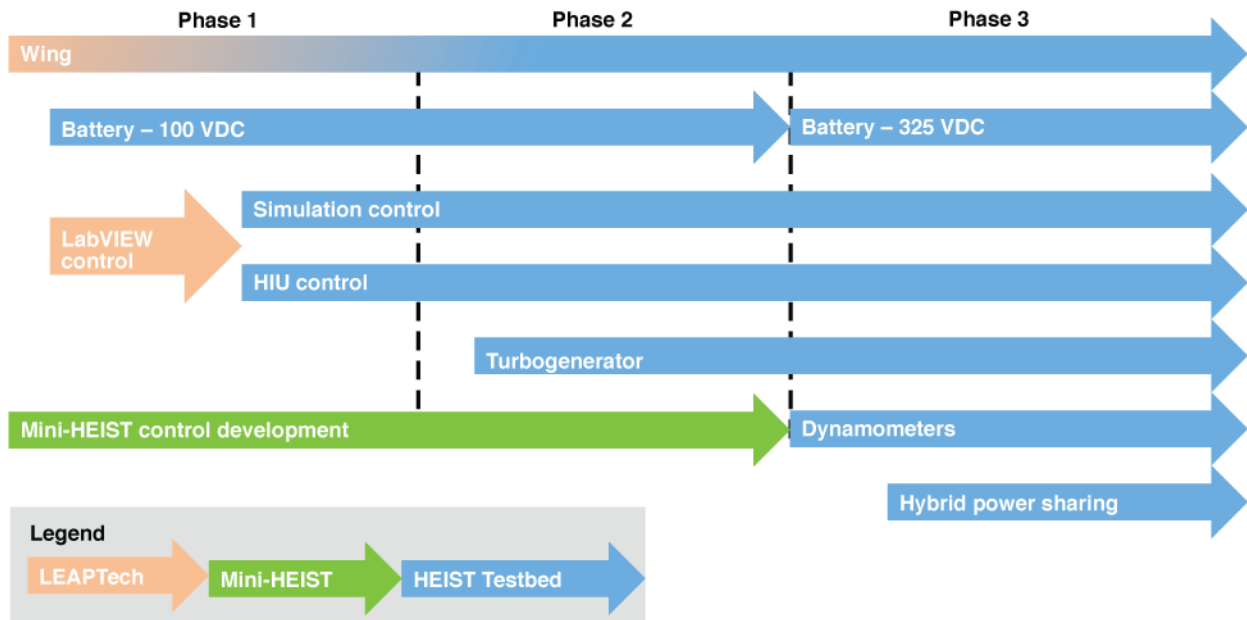

**Figure 5. HEIST Testbed phased approach.**

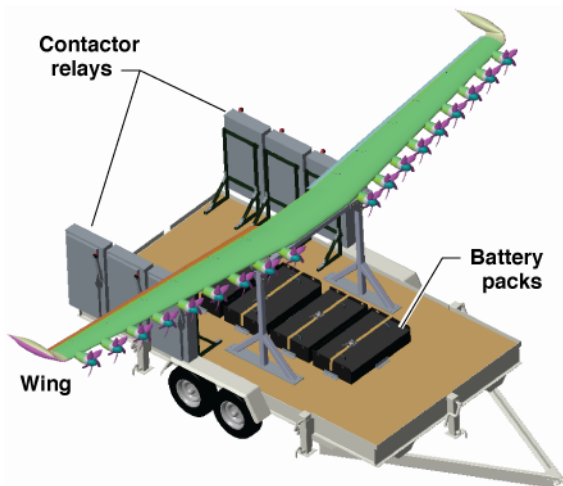
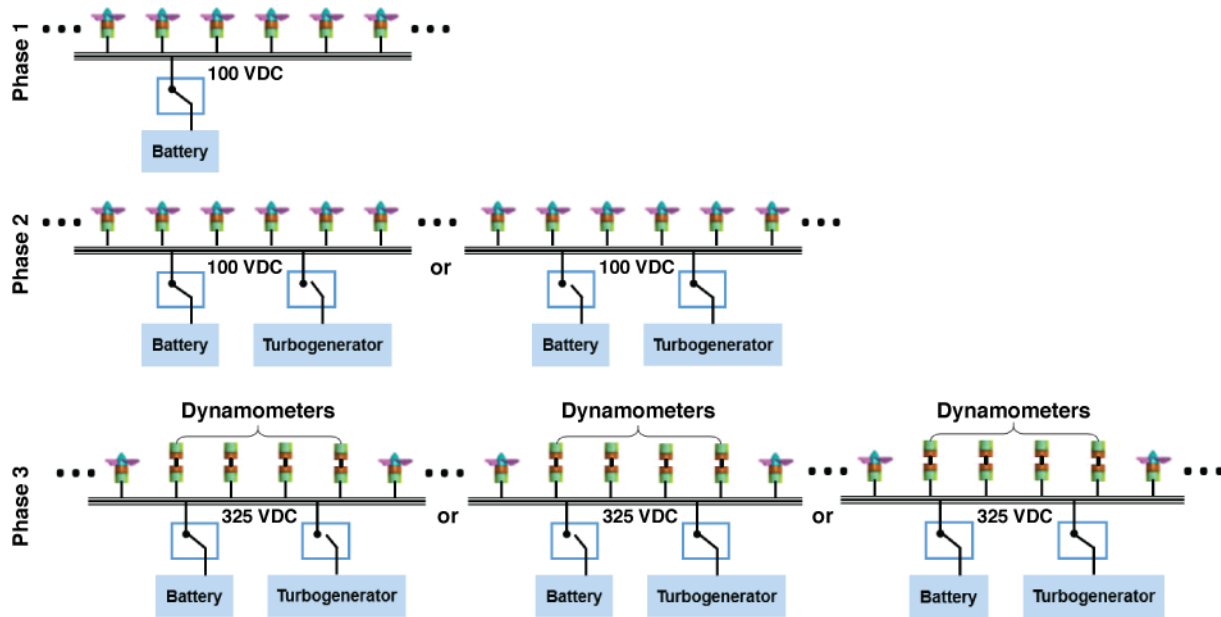

**Figure 6. HEIST Testbed Trailer 1 layout.**

The first phase includes a system checkout and initial hardware development. The wing is removed from the LEAPTech truck and mounted on the wing trailer, as seen in Fig. 6. The batteries and contactor relays are also loaded onto the wing trailer. The HIU and simulation computer are integrated as well. The functionality required for Phase 1 is the ability to drive each motor, each group of motors, and all of the motors simultaneously, with the battery system. Control of the motors will initially be performed by the legacy LabVIEW™ software (National Instruments, Austin, Texas) and then migrate to both HIU direct command and simulation control during the development of Phase 1. Distributed electric propulsion and motor control algorithm buildup will also run in parallel as part of the Mini-HEIST experiment, leading to the integration of the dynamometers in Phase 3.

Phase 2 incorporates the Capstone C65 turbogenerator, AC/DC converter, fuel flow meters, and fuel tank onto a separate trailer (Trailer 2 in Fig. 4). The turbogenerator integration comprises several steps, including communication routing through the HIU (using RS-232), AC/DC converter integration and connectivity through HIU (using RS-485), flow meter integration, calibration, and connectivity through the HIU (using RS-232). Additionally, numeric models for the turbogenerator, created in Numerical Propulsion System Simulation (NPSS®) (Southwest Research Institute, San Antonio, Texas), are added to the simulation computer. Phase 2 functionality is demonstrated by the ability to drive the motors with either the turbogenerator or the batteries. The simulation will include a representative aircraft model with propulsion-only control. Closed-loop simulation using the HEIST hardware will be demonstrated.

The system migrates to the high-voltage bus layout in Phase 3. The rationale for increasing the bus voltage is to start migrate the HEIST Testbed to be more analogous to future TeDP flight demonstrator architectures. The dynamometers and contactor relays are assembled on Trailer 3. With the completion of the dynamometer trailer, the HEIST Project will have completed its three-phase buildup approach for a turbo-electric distributed propulsion modular testbed. The simulation will drive the dynamometers to provide realistic flight loads, and control over power sources will be shown.



**Figure 7. Hybrid power buildup approach.**

The HEIST design will allow NASA engineers to drive the system using battery only, turbine only, or both, as a fully-parallel hybrid system once the system is fully developed in Phase 3, as shown in Fig. 7. The battery system will be able to provide approximately 200 kW, allowing the battery system to simultaneously power the full bed of distributed propulsors; however, the turbogenerator can produce 65 kW, approximately equal to four propulsors or the four dynamometers. This limitation led to the decision to group the two outermost motors on each wing separately. In this way, the turbogenerator can power the wingtip propulsors, similar to proposed architectures for future NASA flying demonstrators. Additional ground test hardware, including a 200-kW AC load and a 30-kW DC load bank will provide added testing capability for motor, bus, turbogenerator, and battery systems, as well as aid in the simulation computer development.

The simulation computer will provide the four dynamometers with power profiles specific to the HEIST Testbed, which will be able to emulate the torque exerted by the propellers throughout a mission as well as the windmilling capability and response by the hybrid system. The propellers from the LEAPTech experiment will also provide a load, proportional to static thrust conditions. These propellers represent additional taxing of the bus system, providing an in-depth look at how the system responds under high-load conditions as well as the opportunity to develop a closed-loop, HIL dynamometer-propulsion simulator for a six-DOF turbo-electric system. This approach addresses objectives 2, 4, 5, 6, 7, and 8 of Table 1. The hardware will be connected to the simulation computers and flight control computers using an HIU, allowing for TeDP control algorithm development and forecasting to larger MW systems. These capabilities tie back to objectives 1, 3, and 9 of Table 1.

In the subsections below, each subsystem description and architecture is more thoroughly described.

## **B. Distributed Motors and Controllers**

For the first two phases of the HEIST Testbed development, the motors, controllers, communication network, and bus network will remain unchanged from the LEAPTech experiment. The motors integrated into the leading edge nacelles area JM1's, a custom motor solution from Joby Motors (Santa Cruz, California). The motor controller inverters (MCIs) are commercial-off-the-shelf (COTS) products from MGM COMPRO (Zlin, Czech Republic), the HBC Series TMM 280120-3EI controllers. The motor commands and instrumentation were routed using CANBus.

The motors will provide up to 14 kW of power from a 100 VDC bus; these motors reach full power at 6860 rpm. The motors are combined into groupings with power lines routed through contactor relays, as shown in Fig. 4. These relays allow the test operator to engage or disengage groups of motors, as well as choose which power plant is driving the motor group (the batteries or the turbogenerator). The JM1 motors are air-cooled.

The MGM controllers were designed to handle the high summer temperatures that can be experienced at AFRC during test conditions. The controllers operate over CANBus communicating motor command, speed, voltage, current,

temperatures, and other parameters. The signals are routed through the CANBus node to the simulation computer, flight control computer, and cockpit.

Phase 3 is anticipated to see the motor controller architectures upgraded to a 325 VDC system. These controllers will be provided by LaunchPoint Technologies (Goleta, California).

### **C. Battery and Battery Management System**

The battery system includes twelve 50 VDC battery packs and a BMS. Each pack consists of seven parallel strings of sixteen 3.2 V, 20 Ah cells. These packs are reconfigurable, allowing the HEIST team to power the system with the legacy 100 VDC system from LEAPTech (two packs in series), and to grow to the ~325 VDC high-voltage system (eight packs in series). The combined energy would be 26800 Ah. The BMS will monitor the cell voltage, internal resistance, and temperature of each cell and pass that information to the simulation computer, flight control computer, and cockpit using CANBus protocol.

### **D. Turbogenerator Hardware and Modeling, AC/DC Converter, and Flow Meters**

The turbogenerator is a Capstone C65 grid power generator capable of producing 65 kW at 96,000 rpm. The Capstone C65 was also modeled using NPSS<sup>®</sup> thermodynamic gas turbine modeling software. The software allows examination of steady-state behavior and transient behavior with arbitrary inputs. This model was then converted into a MATLAB<sup>®</sup> / Simulink<sup>®</sup> (The MathWorks, Inc., Natick, Massachusetts) tool for integration into the overall TeDP simulation. Sources of data used to develop the model include detailed cycle measurement of the related Capstone C30 turbogenerator, Capstone published data, and data collected on the C65 data interface console during test runs. The software model was scaled up to match the C65 generator shaft power output. In order to gain better understanding of the cycle and the performance of the C65, a compressor map from an automotive turbocharger was added to allow full cycle convergence and further examination of the cycle. The compressor map was taken from a published map of comparable rotation speed and mass flow.<sup>9,10,11</sup>

The model is used for the development of control laws before the completion of the HIL test article. In addition, the model simulates multi-turbine configurations with real C65 hardware for one of the generators and one or more simulated turbines. This approach allows investigation into multi-turbine dynamics, providing an improved model for future, redundant, large-scale turbo-electric distributed propulsion systems.

The AC/DC converter is a Magna-Power (Flemington, New Jersey) 100 kW MT series converter accepting 480 VAC 3-phase power from the turbogenerator and producing variable DC power (not shown in Fig. 4 for the sake of clarity). This converter communicates using RS232 protocol, which will allow the simulation computer to monitor and alter voltage and efficiency parameters.

The flow meters are Exact Flow IFC15 (distributed by Badger Meter, Milwaukee, Wisconsin) flow meters communicating using RS485 protocol. Fuel flow will be used to calculate energy consumption and efficiency. Both the AC/DC converter and fuel flow meter data will be routed using the HIU to simulation computer. The data from the fuel flow meters allow for analysis of power and energy balance through the C65, improving the modeling of the electrical side of the generator. The NPSS<sup>®</sup> model will be moved into Simulink<sup>®</sup> using T-MATS (Toolbox for the Modeling and Analysis of Thermodynamic Systems) (NASA Glenn Research Center, Cleveland, Ohio).<sup>10</sup> The Simulink<sup>®</sup> model will facilitate modeling of the full HEIST Testbed and contribute to controls development.

### **E. Dynamometer Architecture and Design**

The HEIST Project will utilize dynamometers to emulate the drag, torque, and aerodynamic forces exerted by the propellers in order to better understand how the system responds to representative loads as well as closing the loop for the simulation computer and flight control computer. Each dynamometer will be an assembly of a Joby Motors JM1 motor, a PowerTEC (Rock Hill, South Carolina) brushless DC brake motor, a Joby Motors JM1 a motor controller, COTS brake motor controller, a common shaft, and requisite cabling, infrastructure, and emergency stop equipment. Four dynamometers will be mounted on a separate trailer, and connected using the high-voltage power bus and CANBus. The JM1 motors will be controlled by the custom LaunchPoint controllers, which are the same controllers as those that will be installed in Phase 3. The brake motor will be controlled by a COTS solution using MODBus RS485. Mounting the dynamometers on a separate trailer will provide modularity and flexibility to the design, providing the test engineers with the ability to swap as many as four motors from the LEAPTech wing with the dynamometers. Additionally, having more than two dynamometers in close proximity will provide the researchers with the ability to test how the power system is affected by neighboring motor/propeller groups during testing. Building dynamometers for each motor of the LEAPTech wing was prohibitively expensive, but the HEIST team plans to use four dynamometers to develop loading profiles and extrapolate for the full wing.

While the other motors will be connected to propellers, they still will provide significant loading on the bus. Load and torque profiles are applied to the brake motors, applying representative aerodynamic loads to the drive motors (the JM1 motors).

## F. Communication Bus Architecture

The simulation computer and cockpit are to be located in the Research Aircraft Integration Facility simulation laboratory above the test bay housing the HEIST Testbed, enabling direct communication lines. The simulation hardware contains a PCAN-PCI Express (Peak-System Technik GmbH, Darmstadt, Germany) CANBus card to read from and control the motors using standard CANBus protocol. The HIU, located in the test bay, is to be the interface between the simulation hardware and the HEIST Testbed. The full communication bus architecture is depicted in Fig. 8.

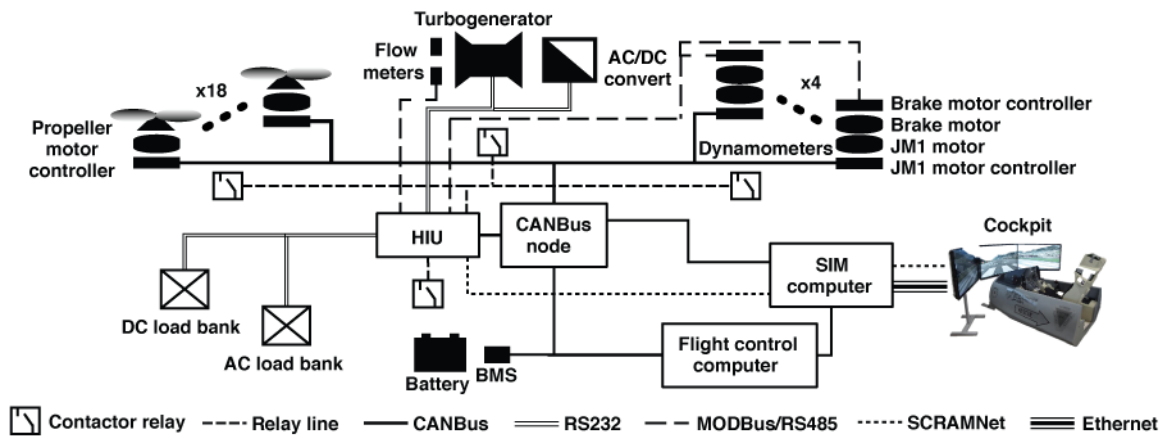

Figure 1. HEIST Testbed communication bus architecture.

Sensors on the HEIST Testbed will be read by the HIU and output to a high-speed reflective memory called SCRAMNet. The simulation computer reads HIU data directly from SCRAMNet for feedback and processing. The simulation computer uses an Ethernet network to output data streams to the AFRC visual feedback programs, such as Real-Time 3D graphics (RT3D), strip chart, Heads Down Display (HDD), and Inter Active Display System (IADS). The IADS server receives data from the simulation computer, then outputs a processed data stream to a private network with IADS display workstations. The IADS display is based on the design requirements from the project. The formatting of the test data visualizations (such as bar graphs, x-y plots, alpha-numerics, custom displays, et cetera) are defined then built up in the IADS software and accessible from the IADS display workstations. These communications capabilities are native features of the AFRC Core simulation framework.

## G. Simulations Computer Architecture and Flight Control Development

The HEIST simulation computer is based on the AFRC Core simulation framework. The framework provides graphical user interfaces, data recording capabilities, interfaces to AFRC visual feedback programs, and the capability for additional hardware and software interfaces. The baseline Core simulation framework is provided with generic vehicle models and those core models that are required for flight dynamics. Models specific to a project test vehicle are replaced in the Core simulation to create a project specific simulation. These models can come from the manufacturers, CFD analysis, wind tunnel data, or Simulink® models. Principle Investigators from aerodynamics, controls, or other disciplines provide models for inclusion into the simulation framework for a high-fidelity simulation. The simulation can then be used entirely in software (batch simulation), and with the addition of communication buses (CANBus, SerialBus, MODBus) the simulation supports HIL, pilot-in-the-loop (PIL), and vehicle-in-the-loop (VIL) testing. Phase 1 of the project will support Mini-HEIST using a CANBus interface to control small-scale motors and induce torque to measure drag. The Mini-HEIST experiment is a precursor to testing with full-scale dynamometers.

The control development is maturing alongside the hardware development. Initially, the model development will verify propulsive elements and how they behave, in essence, trying to model the hardware behavior to better map those behaviors into the model. The controls development will begin in a “software-only” capacity. As the control

algorithms mature, they will be tested on the HEIST Testbed hardware until the hardware, simulation, and control have progressed to Phase 3.

Once the dynamometers are integrated into the HEIST Testbed system architecture, the flight control algorithms can be tested in a closed-loop capacity by driving the brake motors of the dynamometers with representative drag loads. This method will provide the researchers at AFRC with the ability to model drag and torque on the propellers and formulate control strategies for distributed propulsion control augmentation and power management strategies.

In the interim, Mini-HEIST will provide a good springboard for control development and power management, especially as an introduction to dynamometer control. The controls approach for Mini-HEIST will apply a torque to the brake motor and observe how the drive motor responds in speed control mode. These applied torques are analogous to drag on the propellers for different operating conditions. This relationship directly maps to the larger dynamometers available in Phase 3.

#### **H. Turbo-electric Distributed Propulsion Flight Control Research Objectives**

Flight controls research is a primary driver for the HEIST Project, specifically delving into differential thrust, distributed propulsion control, control authority, system health, and transients of the electric bus architecture and turbomachinery. Early integration of these control algorithms and simulation with the HEIST hardware will provide information on potential issues on adverse interactions with the hybrid electric power system. Flight control algorithms will initially reside in the simulation computer. A trade study will identify representative hardware for the flight control computer (FCC). In later phases of HEIST Testbed development, the control algorithms will be hosted in the FCC.

Two aspects of flight controls for distributed electric propulsion are planned to be studied during the HEIST Project: propulsion control to augment normal control surfaces during maneuvers, and power management control to maximize the effectiveness of the turbogenerators and batteries. To accomplish these goals, check cases are being developed to understand the worst stress cases for control augmentation and developing strategies to maximize range, system efficiency, or other figure of merit.

#### **I. Instrumentation Design**

The HEIST instrumentation is to consist of sensors located at various locations of each subsystem; their data will route to the HIU data acquisition (DAQ) unit for recording. Simultaneously, sensor data will also be relayed to the simulation computer. For measurement of bus voltage, a LEM<sup>®</sup> CV 3-500 (LEM, Geneva, Switzerland) unit will be used to measure the DC voltages of the battery subsystem, the output of the turbogenerator AC/DC converter, and each of the four dynamometer channels. The LEM<sup>®</sup> units will be located between the power sources (output of the AC/DC converter and batteries) and power sinks (dynamometers). For current measurements, LEM<sup>®</sup> CV LF 305-S (and LF 505-S) units will also be placed in the same location. Each motor controller channel will provide voltage, current, and temperature to the DAQ, and each motor will provide motor temperature and speed, using CANBus. The battery management subsystem will provide battery health data and state of charge using CANBus. Temperature sensors are mounted to the battery case for independent temperature monitoring.

The turbine shaft speed, inlet and exhaust temperature, power generation, and load information from the Capstone C65 turbogenerator will be communicated to the HIU/simulation computer using RS-232. The dynamometer subsystem provides information on the torque, voltage, current, speed, and accelerometer data using CANBus. The sensor packages for the dynamometers are currently being developed. Emergency stop signals will also be provided from the dynamometer to the instrumentation system to indicate any auto-shutdown faults. An overview of the HEIST Testbed instrumentation capability is given in Table 2.

**Table 2. HEIST Testbed instrumentation capability.**

<b>Data</b>	<b>Subsystem</b>	<b>Description</b>
DC bus voltage	Battery, AC/DC converter (output), each dynamometer	Measure bus voltage at each node of power bus to demonstrate hybrid power-sharing capability
Bus current	Battery, AC/DC converter (output), each dynamometer	Measure current for at each node of to demonstrate hybrid power-sharing capability
Motor data	Motor controllers MGM <sup>Note 1</sup> (Phases 1 and 2) and LaunchPoint <sup>Note 2</sup> (Phase 3)	Motor controllers provide voltage, current, and temperature of the motors for motor performance
Battery data	BMS	Individual cell voltages and temperatures for battery health
Temperature	Battery case	Monitor battery temperature for battery safety and alert if battery shutdown is needed
Turbogenerator data	Turbogenerator	Shaft speed, inlet and exhaust temperature, power generation and load for turbogenerator performance
Fuel flow	Fuel flow meters	Measure fuel flow to determine fuel consumption and energy efficiency

Note 1: MGM COMPRO (Zlin, Czech Republic).

Note 2: LaunchPoint Technologies (Goleta, California).

#### **J. Cockpit and Hardware Interface Unit Design**

The piloted cockpit provides roll, pitch, yaw, and throttle commands to the simulation computer using the simulation electric stick (SES) interface. This interface is part of the cockpit interface system (CIS), which consists of a National Instruments embedded controller and I/O boards. The SES portion of the CIS has the software for the feel and servo loop control for the pilot control interface. For the HEIST Testbed, the pitch and roll have force feedback. The yaw is provided by a spring-loaded rudder pedal with position feedback. The pitch, roll, and yaw commands are processed and published on the SCRAMNet shared memory network. The simulation computer picks up the SCRAMNet signal and processes the data. The throttle positions are read and scaled by the CIS software and published to SCRAMNet on the same National Instruments chassis.

The DAQ system is to consist of a National Instruments (NI) PXIe-1065 chassis, an NI PXIe-8135 Core i7 central processing unit, an NI PXI-6133 data analog-to-digital acquisition cards, an NI PXI-8430 four-port RS-232 interface card, a SCRAMNet GT shared memory card, an NI PXIe-4357 RTD input module for temperature sensors, and an NI PXI-8511 two-port CANBus interface card. Sensor signal conditioning and filtering will be implemented on custom-printed wiring board. The filters will consist of either passive RC filters or active op-amp filters, depending on the type of sensor involved, for EMI and anti-aliasing functions. For control of large contactor relays, NI PXI-2586 relay switches are to be used to toggle the Tyco (TE Connectivity, Berwyn, Pennsylvania) EVC 500 contactors. The SCRAMNet card will provide data connectivity between the HIU, simulation computer, and the cockpit. Instrumentation displays for the user will be developed using IADS software on PC computers.

#### **IV. HEIST Testbed Testing Strategy**

The testing strategy for the HEIST Testbed includes system, subsystem, and component-level testing. Test configurations include individual motor and motor controller assemblies, each motor group, all battery-powered motors and controllers, all turbine-powered motors and controllers, all motors (both battery- and turbine-powered), and the fully-parallel hybrid conditions in which both batteries and turbine are powering the same motor group(s). Means of verification will include test, demonstration, analysis, simulation, or inspection, depending on the system or subsystem requirements. The strategy for testing includes testing for system checkout and testing for specific flight controls and power management research. The system checkouts will occur throughout the development of the HEIST Testbed, and flight controls and power management research will be conducted on Mini-HEIST initially, migrating to an all-software solution, and then finally on the full system, with the completion of Phase 3.

Initial testing on the HEIST Testbed will include wing, battery, HIU, simulation computer, flight control computer, and cockpit subsystem testing. For Phase 1, the primary testing objective is comparing the system functionality to the LEAPTech experiment, and demonstrating that the motors/propellers can be operated by the LabVIEW™ seat (from

the LEAPTech experiment), the HIU, and the simulation computer. Flight controls testing will be conducted on the Mini-HEIST hardware and in an all-software capacity for simulations development.

By the completion of hardware integration for Phase 2, the test engineers hope to have demonstrated that the motors/propellers can be driven by either the batteries or the turbogenerator via the HIU and the simulation computer. The AC/DC converter (Magna-Power 100kW MT series) power envelope will have been verified. The testing is planned will be completed with a suitable resistive load bank, which can be configured for a DC power connection. Verifying function of the converter will improve confidence in the system and simplify possible future troubleshooting. Additionally, testing will allow characterization of the conversion losses, improving the model.

With the system migration to the high-voltage bus architecture in Phase 3, additional testing avenues will be available. The high-voltage motor controllers are planned to be tested to demonstrate the same functionality as the lower-voltage systems. Also, Phase 3 development includes the dynamometers, requiring their own set of checkout cases. The power architecture, signal routing, and contactor relay system are planned to be demonstrated during the dynamometer checkout tests, which include powering the dynamometers with the turbogenerator, batteries, and both systems during a hybrid power-sharing mode.

Table 3 shows a proposed high-level testing strategy for the HEIST Testbed development. Each test described in Table 3 would have multiple intermediate steps; the planned general buildup testing approach is presented. Several test items, specifically the last item for Phase 3 testing (specific objective research data collection testing) tie back into the HEIST Testbed objectives presented in Table 1.

**Table 3. HEIST Testbed proposed testing outline.**

Phase	Test description
Phase 1	Command motor/controller systems on low-voltage (100 VDC) battery power with LabVIEW™
	Command motor/controller systems on low-voltage (100 VDC) battery power with HIU
	Command motor/controller systems on low-voltage (100 VDC) battery power with SIM
	JM1 motor map testing
	(Mini-HEIST) Single coupled motor-pair CANBus torque/speed testing
	(Mini-HEIST) Four coupled motor-pair CANBus testing
	(Mini-HEIST) Open-loop (rpm) speed demand testing from simulator
	(Mini-HEIST) Open-loop torque demand testing from simulator
	(Mini-HEIST) Closed-loop torque and speed testing
	(Mini-HEIST) Testing with scaling tables applied in simulation
Phase 2	Turbogenerator, AC/DC converter and fuel flow meter functional checkout testing
	Command motor/controller systems on battery OR turbogenerator power (100 VDC) with HIU
	Command motor/controller systems on battery OR turbogenerator power (100 VDC) with SIM
Phase 3	Command motor/controller systems on high-voltage (325 VDC) battery power with HIU
	Command motor/controller systems on high-voltage (325 VDC) battery power with SIM
	Dynamometer checkout testing on battery OR turbogenerator power (325 VDC) with HIU
	Dynamometer checkout testing on battery OR turbogenerator power (325 VDC) with SIM
	Hybrid power-sharing testing on battery AND turbogenerator power (325 VDC) with HIU
	Hybrid power-sharing testing on battery AND turbogenerator power (325 VDC) with SIM
	Specific objective research data collection testing

Once the high-voltage dynamometers, turbogenerator, AC/DC converter, and motor controllers have been acceptance tested, the hybrid power-sharing testing can begin. This testing represents one of the biggest integration and test hurdles before the system can be fully operational. Hybrid power-sharing testing will explore how the power bus responds to two power sources and multiple power sinks. During these tests, manipulation of the AC/DC converter will also be explored, as it represents a buffer between the AC power generated from turbine and the primary DC power bus provided by the battery system. Design of experiments are to be conducted during this step of the system checkout testing, as testing strategies and priorities are expected to become clear as the team progresses through the various precursor systems checkouts.

Baseline mission profile testing is planned to include exercising the distributed electric propulsion system, the turbo-electric hybrid power architecture, dynamometers, and the simulation computer, flight control computer, and cockpit. An example hybrid electric mission profile would resemble the power schedule seen in Fig. 9.

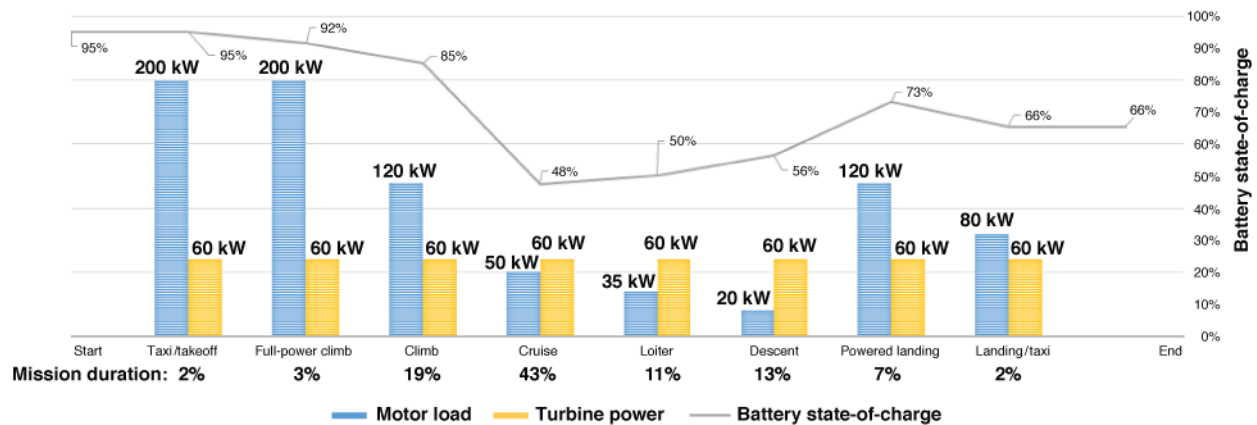

**Figure 9. Hypothetical hybrid electric mission profile.**

The blue bars represent the load consumed by the distributed motors; the yellow bars represent the power produced by the turbogenerator. The difference represents the contribution of the battery to the motor load. For the taxi/takeoff, full power climb, climb, powered landing, and landing/taxi segments, the turbogenerator does not produce enough power to cover the commanded motor load, so the batteries provide the headroom. During cruise, loiter, and descent, the turbogenerator provides more than ample power for the distributed motors, so the headroom charges the battery. The gray line represents the battery state-of-charge throughout the mission. For this mission, the turbogenerator acts as a power generation device only, and the battery system is providing the on-demand power. After the test is complete, the actual power numbers, fuel consumed, and battery power used will be overlaid onto the prescribed mission profile to identify system efficiencies and behaviors. Numerous other mission profiles are planned to be tested, as shown in the objectives in Table 1.

Flight controls research testing will push the system further by looking into stress cases for maneuvering, taxing the propulsion system and observing the response, and delving into the failure modes and effects tests (FMET). System failures will be explored, including how the system responds to battery power, turbogenerator power, individual propulsors and groups of propulsors, communication network, and other failures. Ultimately, the goal is to develop a robust controller that utilizes the FMET models.

## V. Conclusion

The HEIST Project represents a significant milestone toward bringing turbo-electric distributed propulsion (TeDP) technologies to flight. The HEIST Testbed provides the National Aeronautics and Space Administration (NASA) with a distributed electric, turbine-battery hybrid power system, power bus integration experience, piloted simulation, and opportunity to develop TeDP control algorithms, so that risks associated with flying a future TeDP demonstrator can be greatly reduced. The distributed electric wing is a legacy item from the LEAPTech truck experiment. There are approximately 200 kW of batteries and 65 kW of turbo-generation. The system includes the TeDP hardware, assembled on trailers for increased mobility, simulation computer, flight control computer, and cockpit. Testing is planned to be divided into two categories: system and subsystem checkout, and TeDP testing. During the phased-development approach, system and subsystem testing will represent integration milestones toward the completion of this project. When the system is fully functional, research into flight controls and power management will begin on the full testbed. Specific research objectives include developing TeDP control algorithms for aircraft maneuver augmentation, exploring climb and descent schedules with a TeDP system, and identifying design and integration relationships for distributed electric propulsion systems. Additionally, experience and capabilities gained through the development and testing of the HEIST test article will help assess the flight readiness of future hybrid electric and distributed propulsion flight-test activities.



## References

- <sup>1</sup>Styring, P., Quadrelli, E. A., and Armstrong, K., *Carbon Dioxide Utilisation: Closing the Carbon Cycle*, 1<sup>st</sup> ed., Elsevier, Waltham, MA, 2015, Chap. 16.
- <sup>2</sup>National Aeronautics and Space Administration, *NASA Aeronautics Strategic Implementation Plan*, NP-2015-03-1479-HQ, National Aeronautics and Space Administration, Washington, DC, 2015.
- <sup>3</sup>National Aeronautics and Space Administration, *Armstrong Flight Research Center Strategic Goals Quick Guide*, National Aeronautics and Space Administration, Washington, DC, 2015.
- <sup>4</sup>Smith, J. P., Schilling L. J., and Wagner, C. A., "Simulation at Dryden Flight Research Facility From 1957 to 1982," NASA TM-101695, 1989.
- <sup>5</sup>Binkley R. L., and Mackall, D., "System Overview of the NASA Dryden Integrated Test Facility," NASA TM-104250, 1992.
- <sup>6</sup>Mackall, D., McBride, D., and Cohen D., "Overview of the NASA Ames-Dryden Integrated Test Facility," NASA Technical Memorandum 101720, 1990.
- <sup>7</sup>*Hybrid Electric Propulsion Strategy Chart*, Aerodynamics Research Mission Directorate, February 2016. Available from Starr Ginn, Deputy Aeronautics Research Director of the NASA Armstrong Flight Research Center.
- <sup>8</sup>Choi, B. B., Morrison, C., Dever, T., and Brown, G. V., "Propulsion Electric Grid Simulator (PEGS) for Future Turboelectric Distributed Propulsion Aircraft," AIAA-2014-3644, 2014.
- <sup>9</sup>Lee, J. J., Yoon, J. E., Kim, T. S., and Sohn, J. L., "Performance Test and Component Characteristics Evaluation of a Micro Gas Turbine Generator," *Journal of Mechanical Science and Technology*, Vol. 21, No. 1, 2007, pp. 141-152.
- <sup>10</sup>Jones, S. M., "An Introduction to Thermodynamic Performance Analysis of Aircraft Gas Turbine Engine Cycles Using the Numerical Propulsion System Simulation Code," NASA/TM-2007-214690, 2007.
- <sup>11</sup>Lytle, J. K., "The Numerical Propulsion System Simulation: An Overview," NASA TM-2000-209915, 2000.