

Extending the Operational Envelope of a Turbofan Engine Simulation into the Sub-Idle Region

Jeffryes W. Chapman*

Vantage Partners, LLC, Cleveland, OH, 44135, USA

Andy J. Hamley,[†] Ten-Huei Guo,[‡] and Jonathan Litt[§]

NASA Glenn Research Center, Cleveland, OH, 44135, USA

In many non-linear gas turbine simulations, operation in the sub-idle region can lead to model instability. This paper lays out a method for extending the operational envelope of a map based gas turbine simulation to include the sub-idle region. This method develops a multi-simulation solution where the baseline component maps are extrapolated below the idle level and an alternate model is developed to serve as a safety net when the baseline model becomes unstable or unreliable. Sub-idle model development takes place in two distinct operational areas, windmilling/shutdown and purge/cranking/startup. These models are based on derived steady state operating points with transient values extrapolated between initial (known) and final (assumed) states. Model transition logic is developed to predict baseline model sub-idle instability, and transition smoothly and stably to the backup sub-idle model. Results from the simulation show a realistic approximation of sub-idle behavior as compared to generic sub-idle engine performance that allows the engine to operate continuously and stably from shutdown to full power.

Nomenclature

Alt	Altitude
C-MAPSS40k	Commercial Modular Aero-Propulsion System Simulation 40k
CFD	Computational Fluid Dynamics
EGT	Exhaust Gas Temperature
FADEC	Full Authority Digital Engine Control
Fnet	Net Thrust
HPC	High Pressure Compressor
LHV	Lower Heating Value
LPC	Low Pressure Compressor
MN	Mach Number
N	Shaft Speed
Nc	Core Speed
Ndot	Shaft Acceleration
Nf	Fan Speed
PR	Pressure Ratio
SM	Surge Margin
Sub	Below
Wc	Corrected Mass Flow

* Aerospace Engineer, 3000 Aerospace Parkway, Brookpark, OH, AIAA Member.

[†] Controls Engineering Intern, 21000 Brookpark Rd., Cleveland OH.

[‡] Research Engineer, 21000 Brookpark Rd., Cleveland OH, MS-77-1, AIAA Member.

[§] Research Engineer, 21000 Brookpark Rd., Cleveland OH, MS-77-1, Senior AIAA Member.

I. Introduction

Traditionally, high fidelity engine models are based on component performance maps and utilize an iterative solving technique to ensure conservation of energy and mass. These types of engine simulations are typically designed to operate only between idle and full power and do not have the ability to function in the sub-idle region.¹ This paper details how to extend an engine model's operational envelope into the sub-idle region, enabling the simulation to operate reliably from full power to shutdown. Model adjustments described in this paper are intended to represent a realistic, robust solution and are meant to be applied to aircraft simulations for pilot training purposes. For design purposes, a higher fidelity approach would most likely be required.

Sub-idle simulation can be broken up into five topics: windmilling, cranking by placing an external torque source on the shaft, purging, combustor relight, and acceleration to idle. This paper will focus on windmilling, purge, and acceleration to idle, where purge and acceleration to idle will be considered mutually exclusive. Purging will refer to the amount of time the engine will be cranked before the engine is relit. Determining successful fuel relight is beyond the scope of this paper and will not be discussed.

Windmilling has been studied quite extensively; engine performance during windmilling operation is a function of engine internal and external geometry as well as the current altitude and Mach number.² When geometries are known, component blade angles and sizes, along with mass flow, may be used to calculate shaft torques.³ This geometry based method of modeling the sub-idle region is typically completed with computational fluid dynamics (CFD) and a deep understanding of internal turbo-machinery operation and geometry. As another option, a component energy loss method may be used to estimate engine performance during windmilling operation.⁴ A third method of modeling windmilling is by extending the compressor and turbine maps that make up the backbone of typical high fidelity turbine simulations.⁵ Determining an accurate model using map extrapolation requires assumptions on compressor and turbine operation, calculations of engine drag, and/or engine data to analyze.⁶ In general, at very low speeds compressor performance will become highly non-linear and will degrade to the point where it will not act as a compressor, but rather a flow stirrer or even a turbine.⁷ As another option, a completely empirical sub-idle model may be created with good engine data or idealized engine performance assumptions. This paper will explore a map extrapolation method that uses an empirical model as backup.

Purging and acceleration to idle models are extensions of the windmilling model, and are added to enable the simulation of restarting the engine and driving it back to idle power. A purge/cranking simulation can be generated by placing an external torque onto the shaft,⁸ and acceleration can be achieved by reintroducing fuel to the burner. Cranking may also be modeled completely empirically using engine data or idealized performance. As mentioned above, this paper will explore a hybrid model that includes extending performance maps and deriving empirical models, therefore both methods will also be utilized in the acceleration to idle and purge models.

Subsequent sections of this paper detail extending the baseline model, creating the sub-idle model, and integrating these models together. Specifically, Section II describes the overall architecture of the updated simulation and includes the baseline engine model, sub-idle engine model, and model transitioning. Development and implementation of the extrapolated baseline model and the creation of an alternate windmilling model is detailed in Section III, followed by a discussion of the restart model in Section IV, and sample operational traces in Section V. Finally, a summary will be given in Section VI.

II. Simulation Overview

Simulation updates described in this paper were applied to the Commercial Modular Aero-Propulsion System Simulation 40k (C-MAPSS40k⁹). C-MAPSS40k is a nonlinear dynamic model of a generic, high-bypass, dual-spool turbofan engine with a thrust capacity of 40,000 lbf. Written in a combination of MATLAB/Simulink and C, the engine simulation offers two main components, a high fidelity 0-D engine model and a control system representative of the Full Authority Digital Engine Control (FADEC¹⁰). The engine model simulation uses a combination of empirical compressor and turbine performance maps and physics based equations. Conservation of energy and mass are upheld using a Newton Raphson type iterative solver to generate realistic characteristic engine data. Combustor modeling assumes fuel is burnt in its entirety at a constant combustion efficiency and adds energy to the flow path based on the lower heating value (LHV) of the fuel source. Engine fuel flow is controlled using a robust PI controller integrated with a series of fuel limiters, which act to maintain key sensed parameters within safety thresholds. C-MAPSS40k was designed to operate between idle and full power with initialization set to a predefined steady state point within the envelope of operation. Updates discussed in this paper mostly deal with enhancements to the engine component of C-MAPSS40k (baseline engine model), while control system modifications are not

discussed in detail, but mainly take the form of integrator windup protection and control bits to denote shutdown, purge, and cranking.

A diagram of the updated engine simulation architecture can be seen in Figure 1, where black and blue portions denote preexisting (baseline) and new components, respectively. Additions include the following:

- 1) Loss of combustion logic that uses engine model configuration parameters BlowOut, PurgeOn, and Shutdown bits to set the BurnerLit signal to false, which indicates the burner is unlit.
- 2) Switching logic that determines when transitions between baseline model and the alternate sub-idle model should occur.
- 3) Alternate sub-idle model that contains the windmilling and the purge models.

During operation, the simulation will typically utilize the baseline engine model, however if the simulation is operating sub-idle and a numerically unstable region is detected (burner is unlit, the engine is sub-idle, and the nozzle pressure ratio drops below a threshold, as detailed later), the simulation will shift operation to a more stable sub-idle model. When a transition request is made, the modeled shaft acceleration is switched from the baseline calculated acceleration to the sub-idle calculated acceleration. While the sub-idle model is being used, the baseline model continues to run using the last available good shaft speed values for convergence.

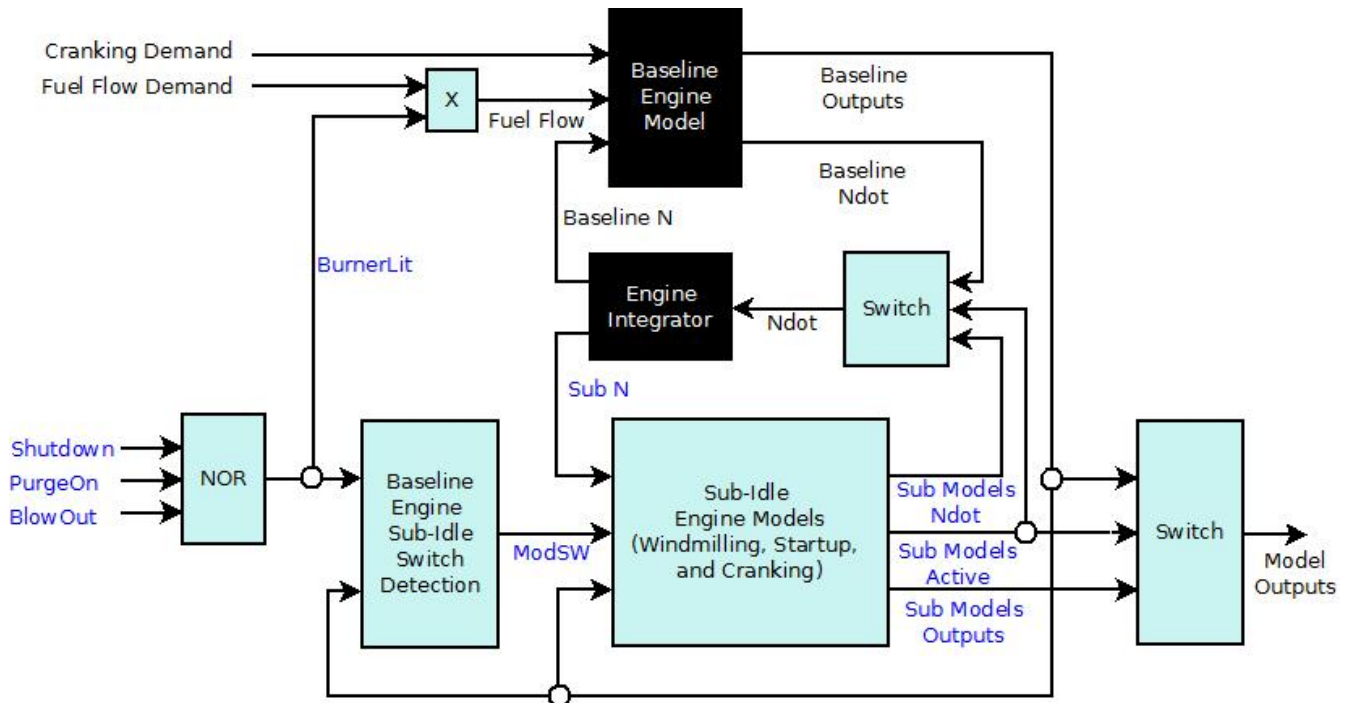

Figure 1. Integrated engine simulation architecture.

III. Development of Sub-Idle Windmilling Simulations

Engine operation in the sub-idle region occurs when combustion ceases and the shaft speeds drift down to an un-aided speed, also known as windmilling speed. Baseline C-MAPSS40k was not designed to operate at these windmilling speeds. To extend the C-MAPSS40k operational envelope, two main methods were used: the baseline compressor and turbine operational maps were extended to allow for low speed running, and an engine performance characteristic model (alternate sub-idle engine model) was developed to be used as a failsafe if the simulation becomes unstable. All updates were completed using a combination of engine model data and idealized engine performance curves.

A. Map Extrapolation

C-MAPSS40k makes use of compressor and turbine maps to solve numerically for component flow, pressure ratio, and efficiency. Current C-MAPSS40k maps are not designed to be run in the sub-idle region of operation and

are undefined at very low mass flow, pressure ratio, and shaft speed operating points. One of the largest challenges to extending a compressor map comes at pressure ratios below 1, when a compressor can act as a mixer or even as a turbine. It should be noted that the authors decided not to extend the compressor maps below unity pressure ratio because these map values could not be extrapolated from the known map values, making convergence very difficult. This ensures the simulation will not converge when windmilling at certain low Mach numbers and solidifies the requirement for an alternate sub-idle model.

Map extrapolation was performed by extending current operation lines toward known operation points. For compressor maps, speed lines were extended toward unity pressure ratio and added at low flow values, and R-lines were added parallel to current R-lines, as shown in Figure 2. In previously undefined regions, speed line form was extrapolated from defined points or created parallel to defined points. Similarly, though not shown here, extension of the turbine maps was accomplished by extrapolating values toward unity pressure ratio at zero mass flow.

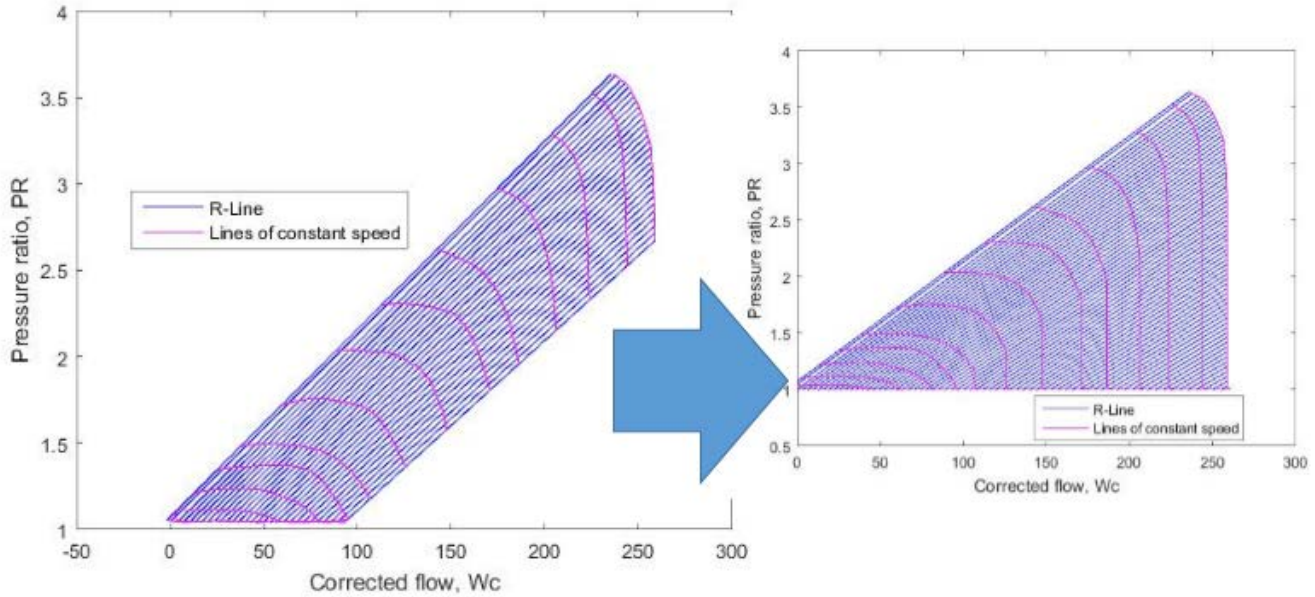

Figure 2. LPC map expansion.

B. Windmilling Model Development

Baseline C-MAPSS40k was designed to operate at power levels between idle and full power. Although sub-idle operation was not in the original plan, the C-MAPSS40k component maps and simulation environment are fairly robust, and operation to certain sub-idle conditions is possible. To determine stable windmilling points, a combustor blow out (fuel failing to combust) was simulated at various points around the envelope by reducing the fuel flow entering the combustion chamber to zero. Mach numbers, 0, 0.2, 0.4, 0.6, and 0.8, and Altitudes, 0, 5,000, 10,000, 20,000, 30,000, 36,000, and 40,000 feet, were tested with characteristics of interest (N_f , N_c , F_{net}) recorded at stable points. Data gathered were used to fit idealized sub-idle operational curves to characterize steady-state windmilling at all sub-idle speeds. It should be noted that net thrust values are based on ram drag only and assume inlet drag and engine body drag are accounted for elsewhere. Baseline windmilling data along with extrapolated data (Figure 3, Figure 4, and Figure 5) was then used as a failsafe windmilling model. Shaft speed transients that govern the transition from the baseline model to the steady-state windmilling model were created by interpolating shaft acceleration between the baseline at transition and zero at the steady state windmilling point. Due to highly nonlinear behavior of thrust in the sub-idle region, thrust transients were instead approximated by a scaled first order transfer function. A switch detection algorithm was used to control transitioning between the baseline model and the sub-idle model and was set to trigger a transition (alternate sub-idle model switch) only when the burner is not lit, the core nozzle pressure ratio is less than 1.01, and core speed is much less than idle (5500 rpm).

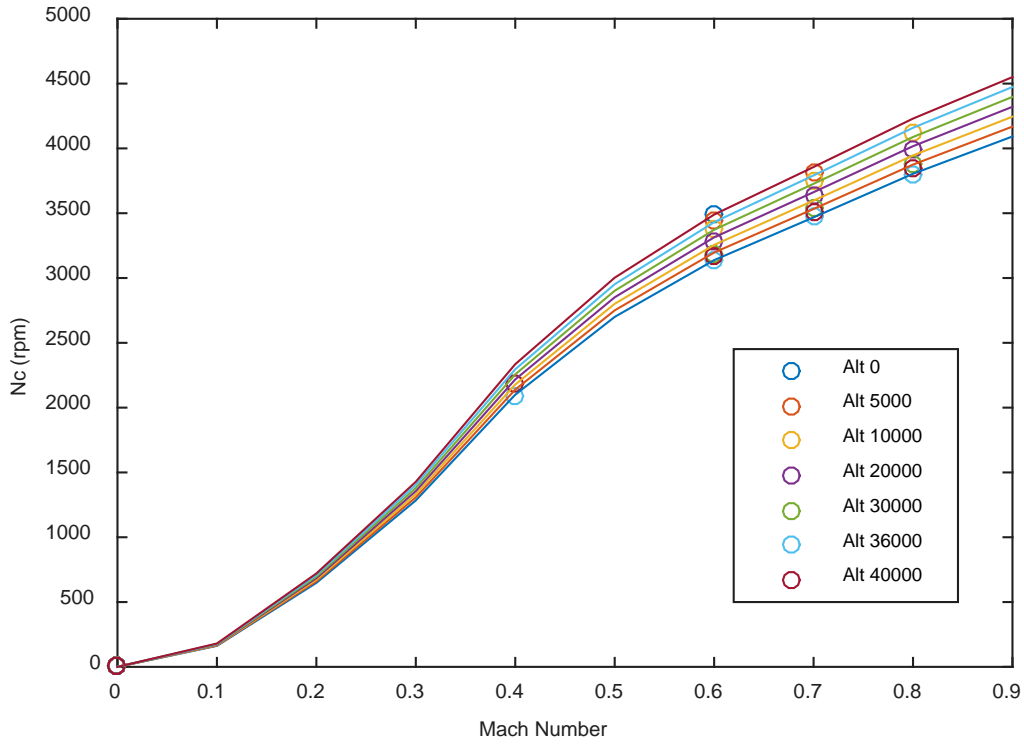

Figure 3. Steady state windmilling Nc, baseline data and extrapolated values.

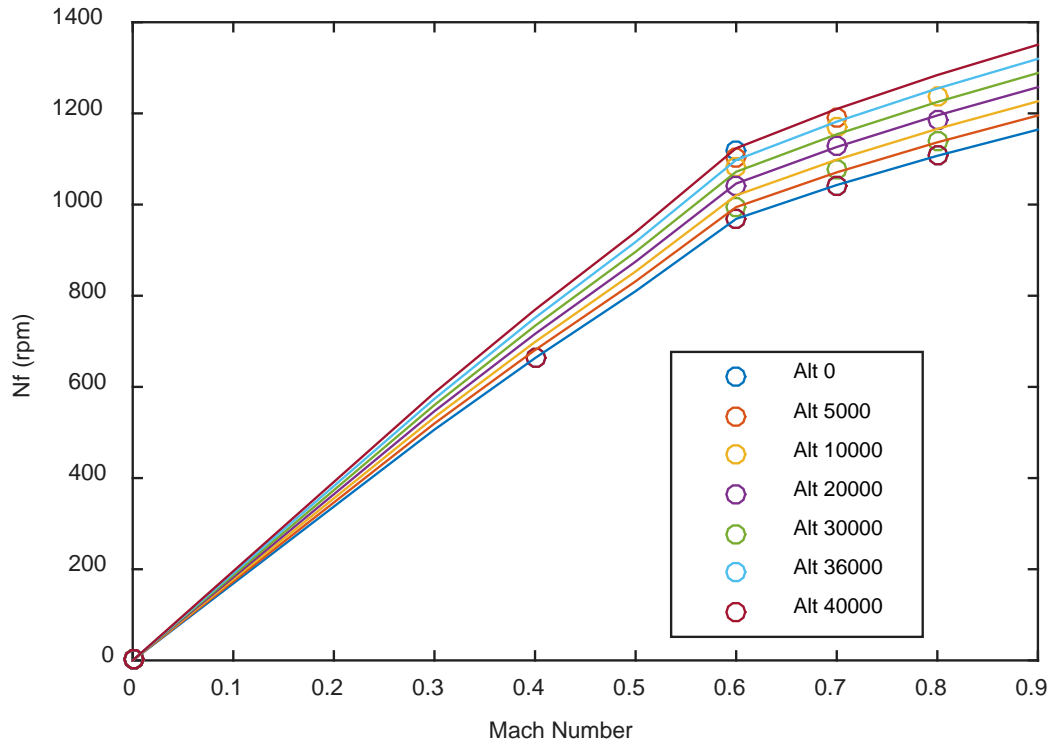

Figure 4. Steady state windmilling Nf, baseline data and extrapolated values.

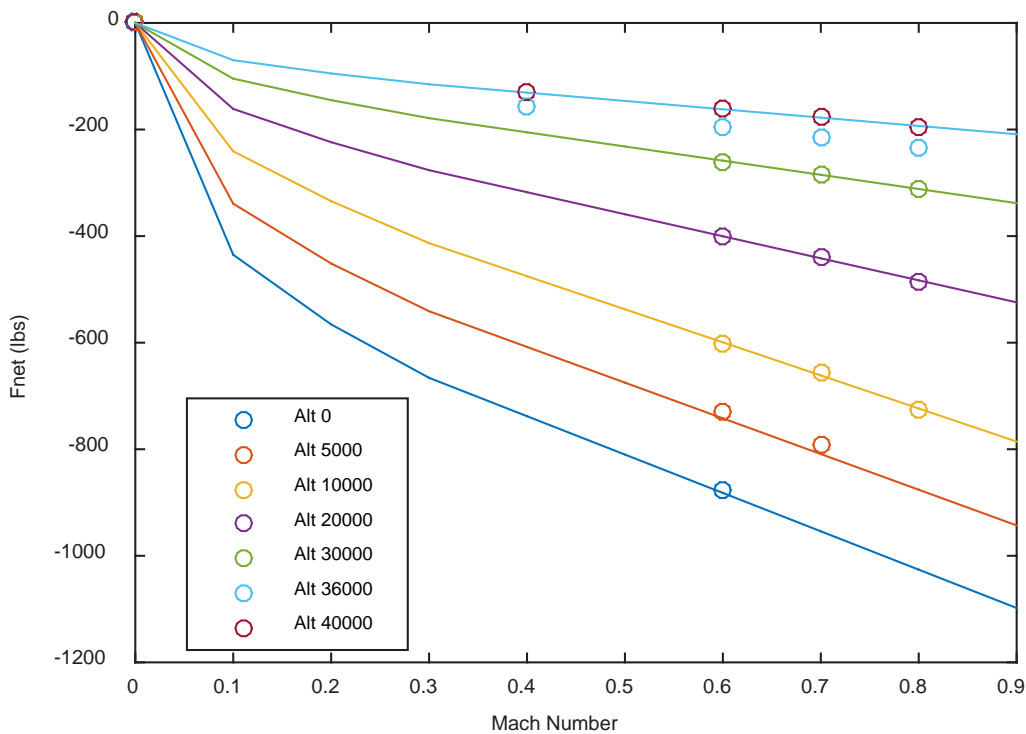

Figure 5. Steady state windmilling Fnet, baseline data and extrapolated values.

IV. Development of the Restart Simulation (Cranking and Acceleration)

This section will discuss how idle speed is reacquired. There are two main steps to restarting: cranking and/or purging the engine, and relight with acceleration to idle.

Before the engine will restart it is typical to purge unburnt fuel from the system. Required shaft speeds and restart duration can vary greatly from engine to engine. Exact start time and relight threshold for C-MAPSS40k are arbitrary, therefore these parameters were selected as 80 seconds and 20% max high pressure shaft speed respectively, and were based on typical values found in literature.⁴ When a restart is requested and relight speed is greater than the current speed, a simulated cranking occurs to increase shaft speed to the required level. This cranking is simulated as a first order transfer function that raises shaft speed to the required light off speed. If shaft speed is greater than or equal to the relight threshold, the simulation will simply attempt to start once a restart command is issued. Models for cranking and required relight speeds were designed to create a stable system with realistic results. If sub-idle engine performance data were to become available, these two models would most likely need to be replaced with more data driven simulations.

Once the engine has reached or exceeded the 20% light off speed requirement and the command for a restart has been given, the engine simulation will relight. Relight is accomplished by reintroducing fuel flow into the baseline engine simulation. Relight is simulated by slowly returning the control requested fuel flow to the baseline engine simulation. When operating under the alternate sub-idle simulation, a return to the baseline model occurs only once the baseline shaft accelerations becomes positive. If the accelerations never achieve a positive value then the models will not transition and there will be a hung start. Requirements for the acceleration to idle were chosen as: engine surge margin (SM) and exhaust temperature must maintain acceptable levels, and the total start time must be under 80 seconds, as mentioned above. To align with these requirements, an external torque (starter) is applied to the high pressure shaft as a function of corrected core speed, see Figure 6. This simulated external torque was tuned to meet the requirements while also following the form of a typical gas turbine starter torque curve.

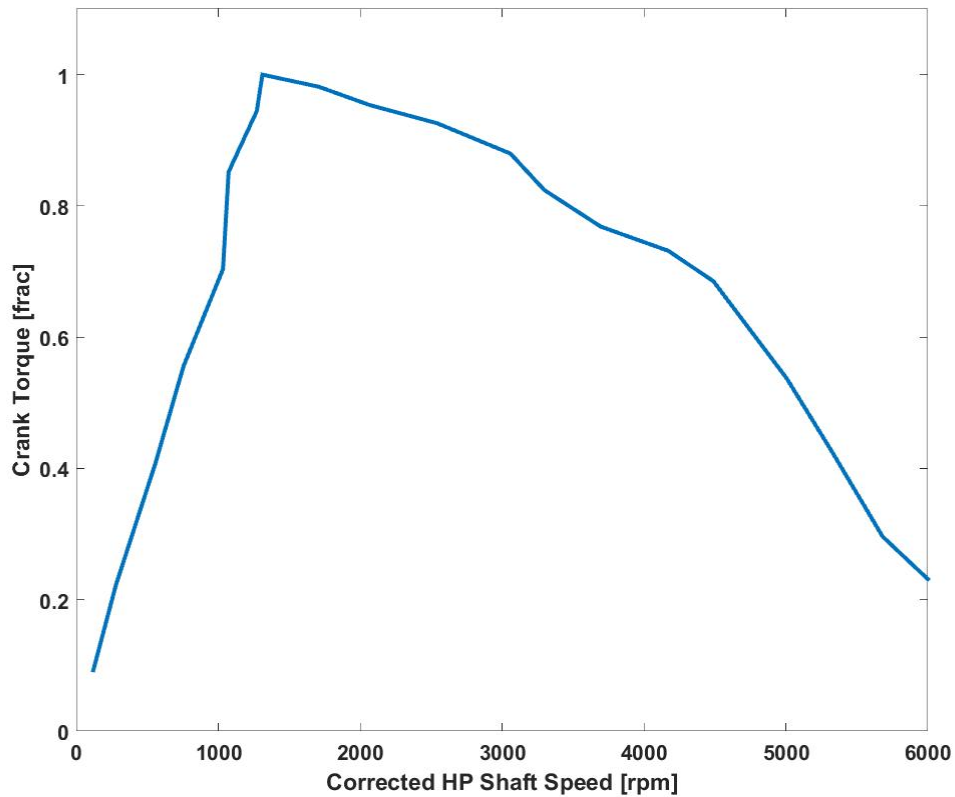

Figure 6. Startup assist crank torque curve.

V. Simulation Operation

Once all sections of the model were complete, the total system was tested at key environmental points to evaluate operation. Three distinct operational regions are presented and shown in Figure 7. In the nominal operating and baseline engine sub-idle windmilling regions, the baseline engine simulation is used, while the alternate sub-idle model region uses the sub-idle model discussed in the previous sections.

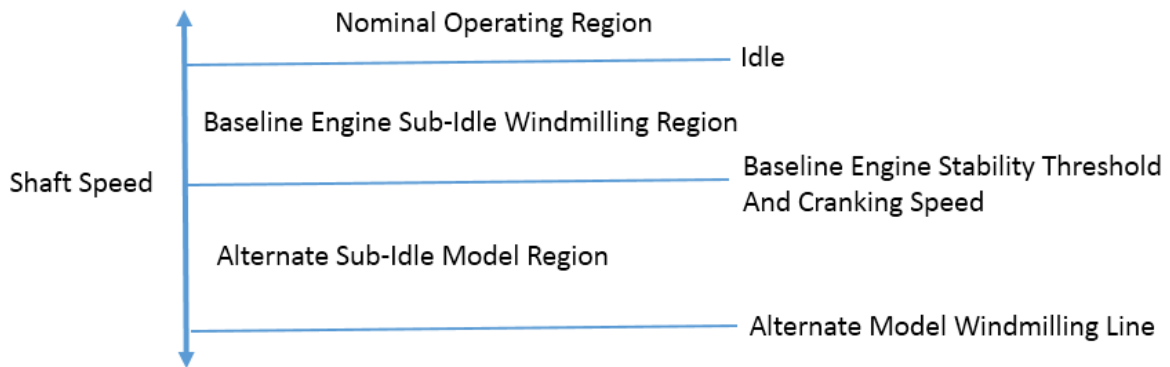

Figure 7. Engine simulation operational regions.

In the first example test, a shutdown then subsequent restart are requested while operating at the engine sea level static condition (0 Mach and an altitude of 0 ft), as shown in Figure 8. The simulation begins at idle, at 20 seconds a shutdown flag is set, fuel is removed from the engine, and the sub-idle alternate model bit (AltSubMod) is triggered (due to low nozzle pressure ratio at sub-idle conditions, as mentioned in Section III,B), switching model type from the baseline to the alternate sub-idle model. The speed then slowly drifts down to the windmilling speed, in this case 0 shaft speed. At 90 seconds a startup is triggered and cranking begins. Nc, Nf, and Fnet rise as the engine purges, and at 120 seconds the purge ends and a relight occurs. Fuel is returned to the engine by the control system and the engine shaft speed moves to idle with a total start time of roughly 70 seconds. Results show all characteristic data generated while operating under the baseline engine simulation and modeled characteristic data generated while operating under the alternate sub-idle model are realistic. Additionally, design limits remain at acceptable levels with EGT below 1400 R and HPC and LPC SMs above 5% while the engine is operating under the baseline model (AltSubMod is false). It should be noted that EGT and SM are not modeled in the alternate sub-idle model, but it can be assumed they are within acceptable limits when the engine is below idle and either shut down or under cranking power only.

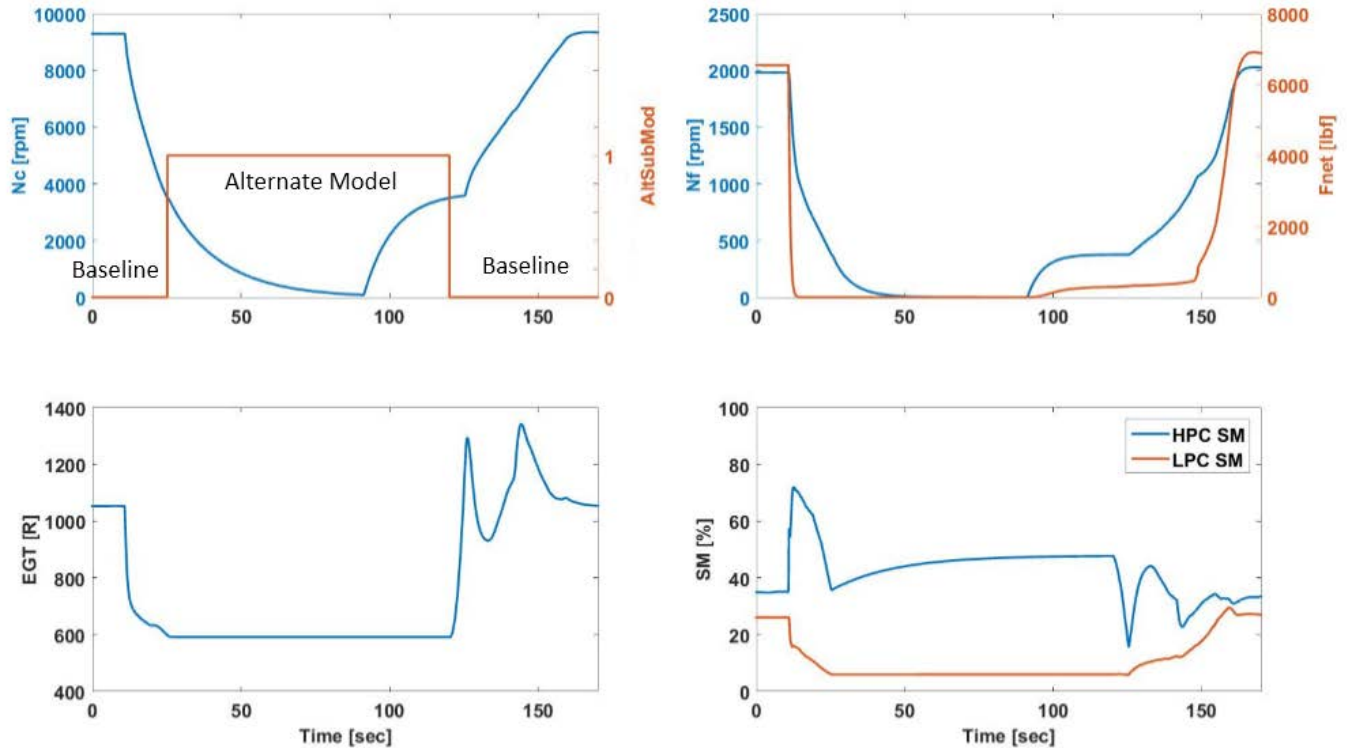

Figure 8. Engine simulation shutdown and restart at zero feet and zero Mach number.

In the second example test, a shutdown then subsequent restart are requested while operating at cruise power level and operating condition (0.8 Mach and an altitude of 36000 ft), as shown in Figure 9. Beginning at idle, the shutdown flag is set at 20 seconds and fuel is removed from the engine. In this case, AltSubMod does not trigger (due to the nozzle pressure ratio remaining well above unity) and the baseline engine model is used to simulate the windmilling event. At 90 seconds a startup is triggered, Nc is above the 20% or 2400 rpm start threshold, therefore a relight is immediately simulated. At 130 seconds the engine achieves the cruise operating point for a total start time of 40 seconds. Results show reasonable and realistic values (when compared to typical engine performance traces) for all characteristic data, with EGT and SM both remaining at acceptable levels during the entire trace, EGT below 1400 R and HPC and LPC SM above 5%.

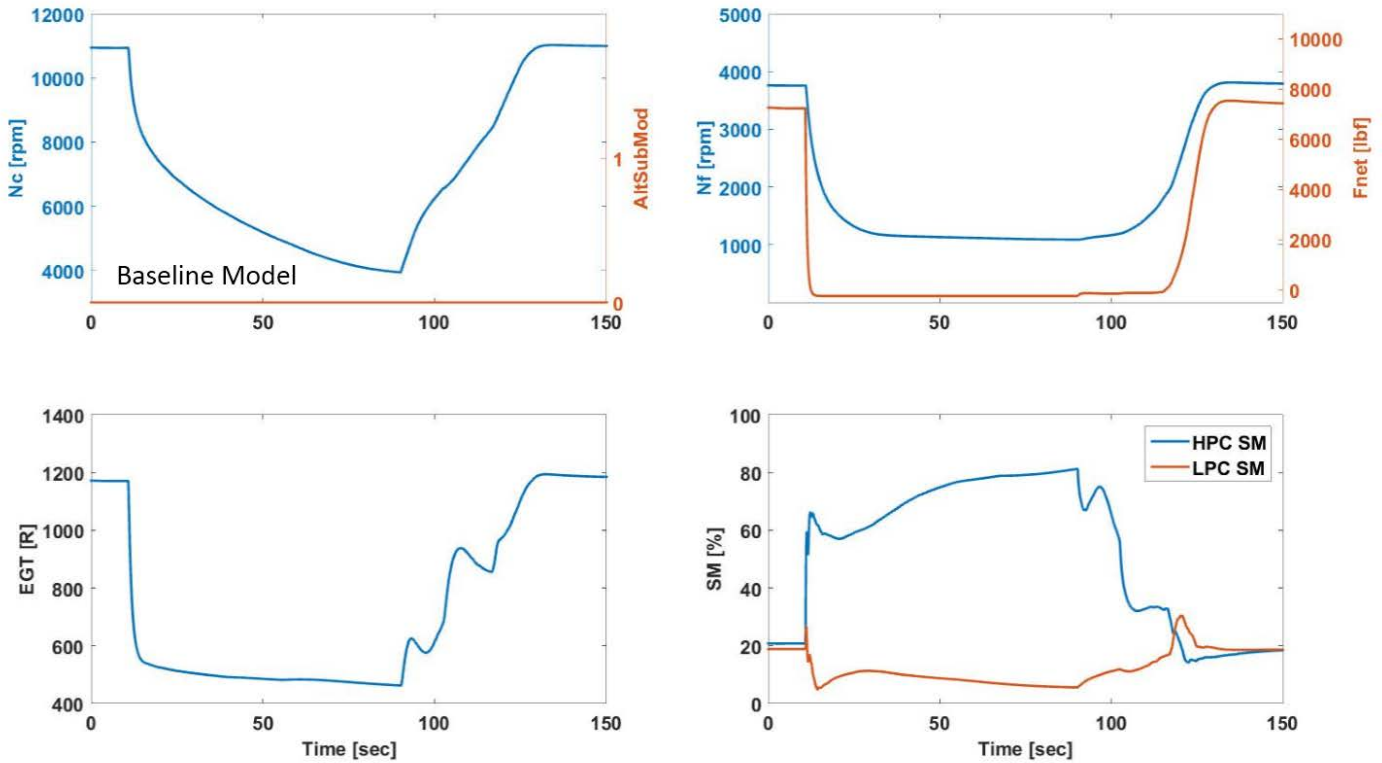

Figure 9. Engine simulation windmilling and restart at 36000 feet and 0.8 Mach number.

VI. Discussion

Given an engine model with an operational range from idle to full power and a dependence on component performance maps, the following techniques may be used to increase the operational range into the sub-idle region.

- Extend the existing performance maps to unity pressure ratio and 0 flow by creating or extending existing speed lines. To gain a higher fidelity model CFD or engine data may be used to generate speed line form.
- Create an alternate “fail safe” model, to account for situations where the baseline model cannot converge.
 - Create a switching architecture to allow smooth transitioning from the baseline model to the alternate sub-idle model.
 - Develop a switching criteria to “sense” an engine shutdown and possible non-convergence situation.
 - Generate empirical models of required signals, such as speed or thrust, for shutdown/windmilling conditions.
 - Generate a restart model that simulates the engine cranking, re-light, and manages the transition from the alternate sub-idle model to the baseline model.

VII. Summary

A stable aircraft engine simulation that is reliable across the entire operational envelope is invaluable when the simulation is required to operate outside the typical idle to full power range. This paper presents several techniques to extend an existing gas turbine engine simulation into the sub-idle region. These techniques include expansion of compressor and turbine performance maps, and the creation of alternate sub-idle failsafe models (windmilling and restart) that can be transitioned to once the baseline simulation becomes unreliable. Sample engine windmilling and restart transients were performed at several altitudes and Mach numbers, demonstrating robust operation and

realistic sub-idle characteristics. Many of the values selected in this paper are representative engine values. Future work could include any of the following:

- Updating engine start times, cranking acceleration, and effects of cranking during light off to be more realistic.
- Adding realistic flight scenario blowout conditions, such as hard decelerations or unrecoverable compressor surge.
- Developing an engine restart envelope to allow relight only when realistic.
- Adding the effects of rotating machinery rub or binding during the large thermal transients that come from a high power shutdown or blowout.

Fortunately, modularity in model construction facilitates these types of updates, as only the affected models would need to be updated to accommodate the changes.

Acknowledgments

The authors would like to thank the NASA Airspace Operations and Safety Program for funding this work.

References

- ¹ Fuksman, I., Sirica, S., “Modeling of a Turbofan Engine Start using a High Fidelity Aero-Thermodynamic Simulation,” Proceedings of ASME Turbo Expo 2012, Copenhagen, Denmark, June 2012.
- ² Borgon, J., “Windmilling of the Rotor of a Turbojet Engine with an Axial-Flow Compressor Under Flight Conditions,” NASA TM-77087, 1983.
- ³ Howard, J., “Sub-Idle Modelling of Gas Turbines: Altitude Relight and Windmilling,” Eng.D. Thesis, School of Engineering, Cranfield University, England, 2007.
- ⁴ Lim, S.K., Roh, T.S., Hong, Y.S., Choi, M.S., Lim, J.S., “Study of Windmilling Characteristics of Twin-Spool Turbo-Fan Engines,” AIAA Joint Propulsion Conference & Exhibit, Reno, NV, Jan 2002.
- ⁵ Kurzke, J., “How to Get Component Maps for Aircraft Gas Turbine Performance Calculations,” ASME Gas Turbine and Aeroengine Congress and Exhibition, Birmingham, UK, June 10-13, 1996.
- ⁶ Zachos, P.K., “Modelling and Analysis of Turbofan Engines Under Windmilling Conditions,” Journal of Propulsion and Power, Vol. 29, No.4, July-August 2013.
- ⁷ Zachos, P.K., “Gas Turbine Sub-idle Performance Modelling Altitude Relight and Windmilling,” Ph.D. Thesis, School of Engineering, Cranfield University, England, 2010.
- ⁸ Walsh, P.P., Fletcher, P., *Gas Turbine Performance*, 2nd ed., Blackwell Science, NJ, 2004, Chaps. 9, 10.
- ⁹ May, R.D., Csank, J., Lavelle, T.M., Litt, J.S., and Guo, T.-H., “A High-Fidelity Simulation of a Generic Commercial Aircraft Engine and Controller,” AIAA-2010-6630, AIAA Joint Propulsion Conference, Nashville, TN, July, 2010.
- ¹⁰ Csank, J., May, R.D., Litt, J.S., Guo, T.-H., “Control Design for a Generic Commercial Aircraft Engine,” AIAA-2010-6629, AIAA Joint Propulsion Conference & Exhibit, Nashville, TN, July, 2010.