

NGSLR Operations Manual

Operating the Next Generation Satellite Laser Ranging System

Jan McGarry, NASA/GSFC/694



Version 1.0

January 2014

NASA-NGSLR-OPS-Manual

Table of Contents

TABLE OF CONTENTS	I
ACKNOWLEDGEMENTS	V
INTRODUCTION	1
1 SAFETY CONSIDERATIONS AND REQUIREMENTS	3
1.1 ELECTRICAL HAZARDS	3
1.2 RADIO FREQUENCY HAZARDS	3
1.3 EYE SAFETY/LASER HAZARDS	4
1.3.1 OUTDOOR LASER HAZARDS	4
1.3.2 INDOOR LASER HAZARDS	4
1.4 LASER SAFETY REQUIREMENTS	6
2 OPERATIONS REQUIREMENTS AND EMERGENCY PROCEDURES	8
2.1 OPERATIONAL CONSIDERATIONS	8
2.1.1 DESCRIPTION OF BASIC RANGING OPERATIONS	8
2.1.2 REASONS TO STOP TRACKING	9
2.1.3 SYSTEM READINESS	9
2.1.4 EQUIPMENT TO BE LEFT RUNNING	9
2.1.5 TEMPERATURE STABILITY INSIDE THE SHELTER	10
2.1.6 COORDINATION WITH OTHER ONSITE SPACE GEODESY TECHNIQUES	10
2.2 LHRS/IOC VERIFICATION	11
2.3 CREW REQUIREMENTS FOR FAA COMPLIANCE AT NGSLR	11
2.4 IN CASE OF IMPROPER FUNCTION OF LASER SAFETY EQUIPMENT	12
2.5 IN CASE OF LASER HAZARD EVENT	12
2.6 EMERGENCY PROCEDURES	13
2.6.1 EMERGENCY CONTACT INFORMATION	13
2.6.2 INJURY/IMMINENT DANGER TO PERSONNEL	13
2.6.3 LASER HAZARD EVENT / CLOSE CALLS	13
3 PREPARING FOR TRACKING OPERATIONS	14
3.1 INITIAL PREPARATIONS	14
3.2 POWER UP SEQUENCE	15
3.3 TURNING ON SUPPORTING EQUIPMENT	24

3.4	SAFETY PROTOCOL PRIOR TO TURNING ON THE SLR LASER	26
3.5	POWERING UP AND STARTING THE SLR LASER CONTROLLER	27
4	<u>PERFORMING TRACKING OPERATIONS</u>	<u>29</u>
4.1	GROUND CALIBRATION	29
4.2	SATELLITE TRACKING PROCESS	34
5	<u>ROUTINE ALIGNMENT VERIFICATION</u>	<u>38</u>
5.1	PERFORMING A STAR CALIBRATION	38
5.1.1	STAR CALIBRATION PROCEDURE	38
5.1.2	VERIFYING THE ADJUSTED POINTING BIASES PRODUCED BY THE STAR CALIBRATION	41
5.2	PERFORMING A STAR ASSESSMENT	44
6	<u>PERFORMING MINICO AND STABILITY TESTS</u>	<u>45</u>
6.1	PERFORMING A MINI-COLLOCATION (MINICO)	45
6.2	PERFORMING A STABILITY TEST	49
7	<u>SHUTTING DOWN THE SYSTEM</u>	<u>52</u>
8	<u>MOST COMMON ERRORS AND THEIR RESOLUTIONS</u>	<u>55</u>
8.1	GETTING THE "MET" ERROR MESSAGE ON POP FOR LONGER THAN 10 MINUTES	55
8.2	NO IMAGE ON THE MONITOR FOR THE TELESCOPE CAMERA	55
8.3	MOUNT WON'T DRIVE / MOUNT DUMPS (ELEVATION > 90°)	56
8.4	THE LASER IS FIRING, BUT THE RAT DISPLAY SHOWS LASER FIRES ARE ZERO (F=0)	56
8.5	THE LASER WON'T FIRE	56
8.6	SYSTEM IS NOT GETTING RETURNS	60
8.6.1	NO RETURNS DURING GROUND CALIBRATIONS	60
8.6.2	LOW RETURN RATE DURING A GROUND CALIBRATION	60
8.6.3	NO RETURNS DURING SATELLITE TRACKING	61
8.7	THE SOFTWARE APPEARS TO HAVE CRASHED/IS NON-RESPONSIVE	61
8.7.1	HOW TO DO A SOFT REBOOT ON POP	61
8.7.2	HOW TO DO A HARD REBOOT ON POP	62
8.7.3	HOW TO DO A SOFT REBOOT ON DAM	62
8.7.4	HOW TO DO A HARD REBOOT ON DAM	62
8.7.5	REMOUNTING THE DISK DRIVES ON POP AND DAM	63
8.7.6	HOW TO DO A SOFT REBOOT ON RAT	63

8.7.7	HOW TO DO A HARD REBOOT ON RAT	63
8.7.8	HOW TO DO A SOFT REBOOT ON THE CAMERA COMPUTER	63
8.7.9	STARTING NFS AFTER TURNING ON/REBOOTING THE CAMERA COMPUTER	64
8.8	EVENT TIMER RESETS	65
8.8.1	EVENT TIMER CONTINUALLY RESETS	65
8.9	DOME WON'T OPEN OR CLOSE	66
 APPENDIX A: ACRONYMS		 67
 APPENDIX B: NGSLR LASER RANGING LOG SHEET		 68
 APPENDIX C: ALERT STATUSES		 69
 APPENDIX D: MEASURING THE LASER POWER		 70
 APPENDIX E: MEASURING THE START DIODE VOLTAGE		 72

Acknowledgements

Removed (jlfm)

The development of NGSLR (formerly SLR2000) is funded through the Science Mission Directorate at NASA Headquarters. This prototype is being developed by the Space Geodesy Project at Goddard Space Flight Center in cooperation with the Laser Remote Sensing Laboratory, both part of the Solar System Exploration Division at Goddard.

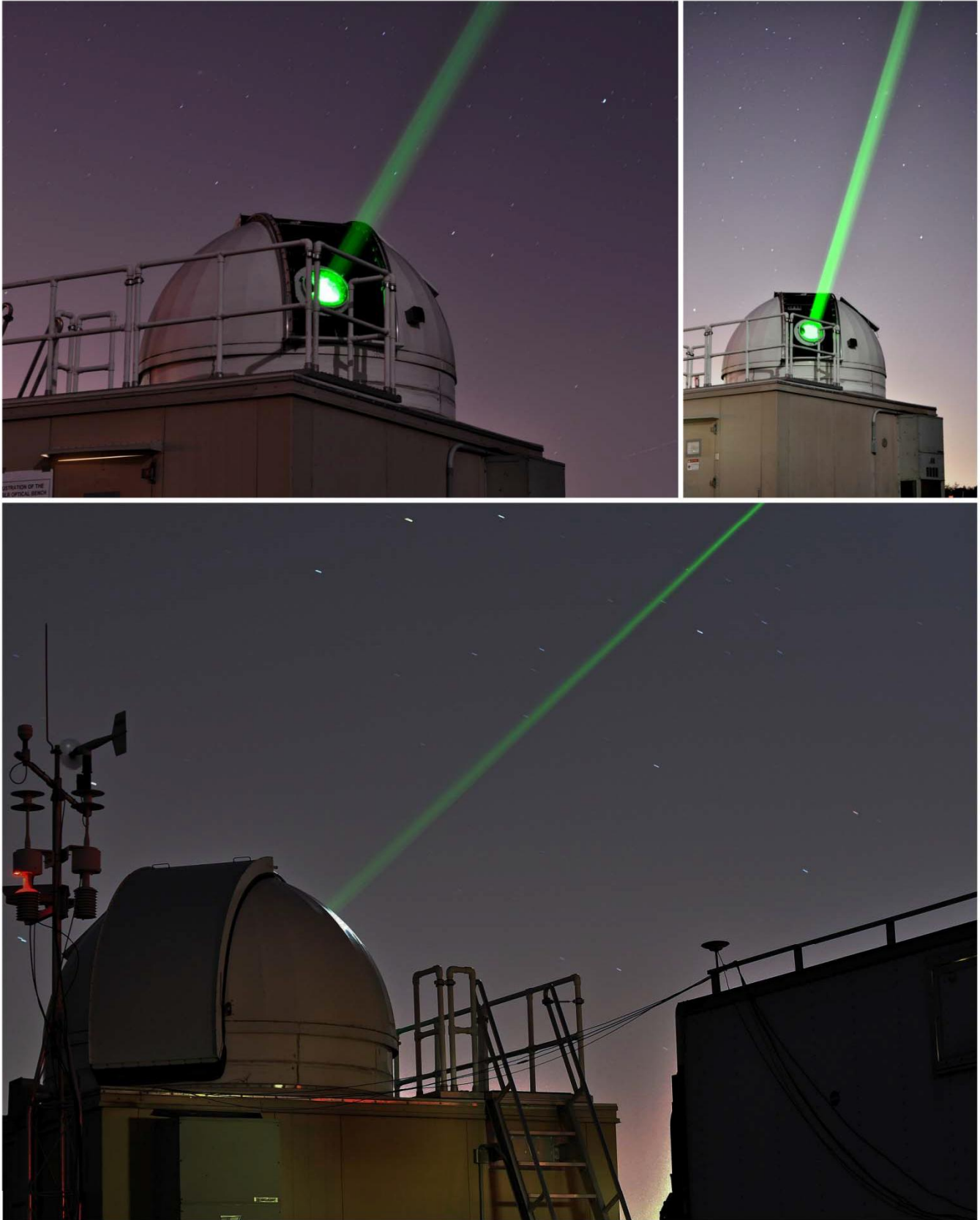

NGSLR tracking at night

Introduction

NASA's Next Generation Satellite Laser Ranging (NGSLR) station is the prototype for NASA's new Satellite Laser Ranging (SLR) systems which will be deployed around the world in the coming decade. The prototype is located at the Goddard Geophysical and Astronomical Observatory (GGAO), one of Goddard Space Flight Center's secure satellite facilities. NGSLR will be a semi-autonomous, single photon sensitive SLR station with an expected shot to shot absolute range accuracy to LAGEOS of better than 1 centimeter and a normal point (time-averaged) range precision better than 1 millimeter.

When operational, the system will provide continuous, 24-hour tracking coverage to an existing constellation of approximately two dozen artificial satellites equipped with passive retroreflector arrays.

When deployed, these stations will be placed so that they have full access to both internet and phone communication, with each system communicating regularly to an external facility (called *Home*). It is from here that the station will obtain the satellite prediction data for the week, receive the tracking priority of satellites, and send information on system health and performance. The *Home* Facility will send technicians periodically and/or when the system needs repair. There is also expected to be a "caretaker" present most of the time at each facility who will monitor the system and its operations.

NGSLR incorporates several key developments that are unique. For instance, existing NASA SLR stations require operators to determine system viability, avoid direct contact of the laser beam with aircraft and ground personnel, decide what objects to track, and interactively acquire and track those objects. However, the NGSLR prototype will be semi-automated, performing many of the above tasks automatically, including incorporating a proven laser hazard reduction system (LHRS) to prevent the lasing of aircraft. In addition, NGSLR uses a low power beam coupled with a high fire rate (2000 Hz), which has the dual benefit of allowing lower per pulse laser energy levels, while increasing the number of possible returns per unit time, hence enhancing the normal point precision. This technique creates a higher return rate per unit time, producing final data products that are the same or better than those from legacy NASA SLR systems.

In addition to the normal 2-way satellite laser ranging, the NGSLR system is capable of supporting other types of laser ranging, including 1 and 2-way asynchronous transponder ranging. Currently, the NGSLR prototype is supporting 1-way laser ranging to the Lunar Reconnaissance Orbiter (LRO), an uplink only range where NGSLR records the laser fire times, and the spacecraft records the receive events. Analysts form ranges after the pass by correctly associating fires with receive events. Further details on the LRO operations at NGSLR can be found in: *Laser Ranging to the Lunar Reconnaissance Orbiter (LRO) from NASA's Next Generation Satellite Laser Ranging Station (NGSLR), (NASA-NGSLR-OPS-LRO)*.¹

¹ Further information can also be found in various papers and presentations including:

Zuber, et al. (2010); Mao et al. (2010); Clarke et al. (2008); Mallama (2008); McGarry et al. (2008); McGarry & Zagwodzki (2009)

Overview of the Document

The purpose of this document is to provide instructions for operation of the NGSLR system.

This document will:

- Describe the general configuration of the system
- Lay out procedures for system power-up and shutdown
- Walk the operator through the normal sequence of events in tracking operations
- Describe regularly performed calibration procedures
- List the most common errors and their resolutions

All steps are listed in a numbered hierarchy, and begin with a summary of what is to be accomplished during each step, followed with a brief description of how to perform the task, along with any pertinent notes, warnings, and troubleshooting steps. The number and the summary description of each step match the steps listed in the operations checklist included in the appendix of this manual.

Example layout of procedures

-
- The diagram shows three red lines pointing to the components of a step: 'Step number' points to the number '1', 'Summary of Step' points to the bolded text 'Fill out the Operations Log', and 'Detailed description' points to the rest of the text in the first step.
1. **Fill out the Operations Log** – At the commencement of your shift, fill out the NGSLR Operations Log, as shown in Appendix B. Make sure to keep this log sheet in a convenient place, as you will continue to enter additional information with each pass / ground calibration that is performed.
 2. **Call the FAA** – Inform the FAA of pending operations immediately after beginning the operations log.
 - a. Call the FAA. *(See the posting in the shelter for the current number)*
 - b. Say something similar to:

“This is Joe Smith at the Goddard Space Flight Center. I am calling to inform you that we are commencing laser ranging operations.”
 - c. Write down the name of person spoken to along with the time in the Operations Log.

The following symbols are used to identify certain types of hazards that exist within the system, along with procedures to mitigate risk. Compliance with the risk mitigation procedures identified in this document and NASA safety guidelines are mandatory.



Possible safety hazard or potential damage to equipment.



Possible laser safety hazard.



Possible electrical hazard.



Possible radio frequency hazard.

1 Safety Considerations and Requirements

NGSLR is operated under the approval of the Occupational Safety and Health Division (OS&H) at the NASA Goddard Space Flight Center and follows all guidelines and requirements established by that office and the American National Standards Institute (ANSI). Because of the system's proximity to multiple airports in the Baltimore/Washington DC corridor, the Goddard Laser Safety Office has mandated additional requirements in cooperation with the Federal Aviation Administration (FAA). These include notification of the National Capital Regional Coordination Center (NCRCC) before and at the conclusion of scheduled laser operations for the week.

The NGSLR and LRO laser ranging programs use a combination of procedures, electromechanical systems, and software to ensure SLR operations are safe. Both systems offer multiple verifications and redundancies to make certain the operations of the system are properly conducted. In addition, all system users are required to comply with the procedures and requirements listed in the NGSLR Safety Manual, the NGSLR Operations Manual, the LRO Operations Manual and the NGSLR System Alignment, Focus and Maintenance Manual.

1.1 Electrical Hazards



Warning: Employees are not permitted to work on any electrical equipment when alone; there is always a two-person rule in effect. Where possible, the power supply should be locked out and reduced to a zero energy state.

Instrumentation and equipment in the NGSLR shelter have no electrical hazard other than the standard 120V / 20A service that runs these devices.

1.2 Radio Frequency Hazards



Warning: Personnel are prohibited from being on the radar tower while the LHRS is in operation, due to possible exposure to elevated levels of microwave radiation. The system must be powered off and locked out prior to maintenance being performed.

Personnel on any adjacent structure should be a minimum of 10 feet away from the radiating antenna in order to minimize exposure to RF energy. Though this distance is a minimum safe distance, exposure to all RF radiation should be avoided whenever possible.

1.3 Eye Safety/Laser Hazards



Warning: The laser(s) can pose a serious visual hazard if proper precautions are not observed. You must understand and follow the precautions listed in the NGSLR Safety Manual and in this manual to ensure safe operation. Failure to follow these guidelines can result in severe eye damage to anyone exposed to the beam. Only personnel who possess the Goddard Laser User certification and are approved by the NGSLR project manager are allowed to operate the laser.

1.3.1 Outdoor Laser Hazards

The SLR and LRO lasers used in NGSLR are not eye-safe and require the use of the Laser Hazard Reduction System (LHRS), a radar-based safety system that blocks the beam if it detects an aircraft approaching an exclusion zone around the transmission path.

The NGSLR system is housed in a controlled area that limits direct access to the system. In addition, pressure pads have been added to the stairway that provides access to the observatory dome. These pressure pads will disable the laser should anyone attempt to access the roof during operations, thereby preventing exposure to laser energy. Personnel are prohibited from remaining on the maintenance deck during operations due to the possible risk of exposure to unsafe levels laser radiation. It is the responsibility of the operations staff to verify that there are no personnel on the maintenance deck prior to commencing operations.

Protective eyewear that meets ANSI Z136 standards for the lasers used in the system are supplied in the NGSLR shelter for use by engineering personnel when verifying the alignment of the beam. Eye protection will be worn within this restricted area whenever the laser is operational. See the table below to select the appropriate eyewear for each laser and power level.

Outdoor Requirements

<i>Northrop Grumman (50 mJ max)</i>	<i>>2.4 OD</i>	<i>(Setting used for LRO Operations)</i>
<i>Northrop Grumman (0.1 mJ setting)</i>	<i>none required</i>	<i>(Setting used for LRO Alignment)</i>
<i>Photonics Industries (1.0 mJ setting)</i>	<i>>1.2 OD</i>	<i>(Setting used for SLR Operations)</i>
<i>Photonics Industries (0.02 mJ setting)</i>	<i>none required</i>	<i>(Setting used for SLR Alignment)</i>

1.3.2 Indoor Laser Hazards

The SLR and LRO lasers operate in the Laser Operations Area (LOA) within NGSLR that protects the operator from exposure during operation of the lasers (Figure 1-1). Each laser is confined to a well defined beam path around the optical bench, where considerable care has been taken to reduce backscatter and reflection off of various surfaces. Any scattered light is collected by the black laser curtain that surrounds the LOA. Due to the high peak power of the lasers on the optical bench, it is imperative that all personnel wear the appropriate degree of eye protection to prevent accidental exposure to laser energy. As such, all personnel in the LOA during operation of either laser are required to wear eye protection as listed below.

Indoor Requirements

<i>Northrop Grumman (50 mJ setting)</i>	<i>>5.6 OD</i>	<i>(Setting used for LRO Operations)</i>
<i>Northrop Grumman (0.1 mJ setting)</i>	<i>>3.0 OD</i>	<i>(Setting used for LRO Alignment)</i>
<i>Photonics Industries (1.0 mJ setting)</i>	<i>>4.7 OD</i>	<i>(Setting used for SLR Operations)</i>
<i>Photonics Industries (0.02 mJ setting)</i>	<i>>3.0 OD</i>	<i>(Setting used for SLR Alignment)</i>

Skin Hazards

The laser can pose a skin hazard if proper precautions are not observed, with the arms, hands, and head as the portions of the body most likely to be inadvertently exposed to the laser beam. At all times personnel are to avoid direct contact with the laser energy by any part of the body or clothing. Even though the heat from the laser beam may cause a flinch reaction before damage occurs, adequate precautions should be taken to avoid contact with the laser beam. All adjustments to the optical bench must be made at a lower power setting, known as alignment power. To mitigate skin hazards, all adjustments to the system during alignment should be performed by reaching in from above in order to clear the beam path. In addition, pay special attention to loose clothing or long hair when reaching over the Optical Bench.

Fire Hazard

The laser beam in the system can create a hazard by burning or damaging materials during short term exposure. Ensure that these materials (including paper, cardboard, clothing, and plastic) do not enter the beam path and that the laser has been properly aligned to reduce stray reflections.

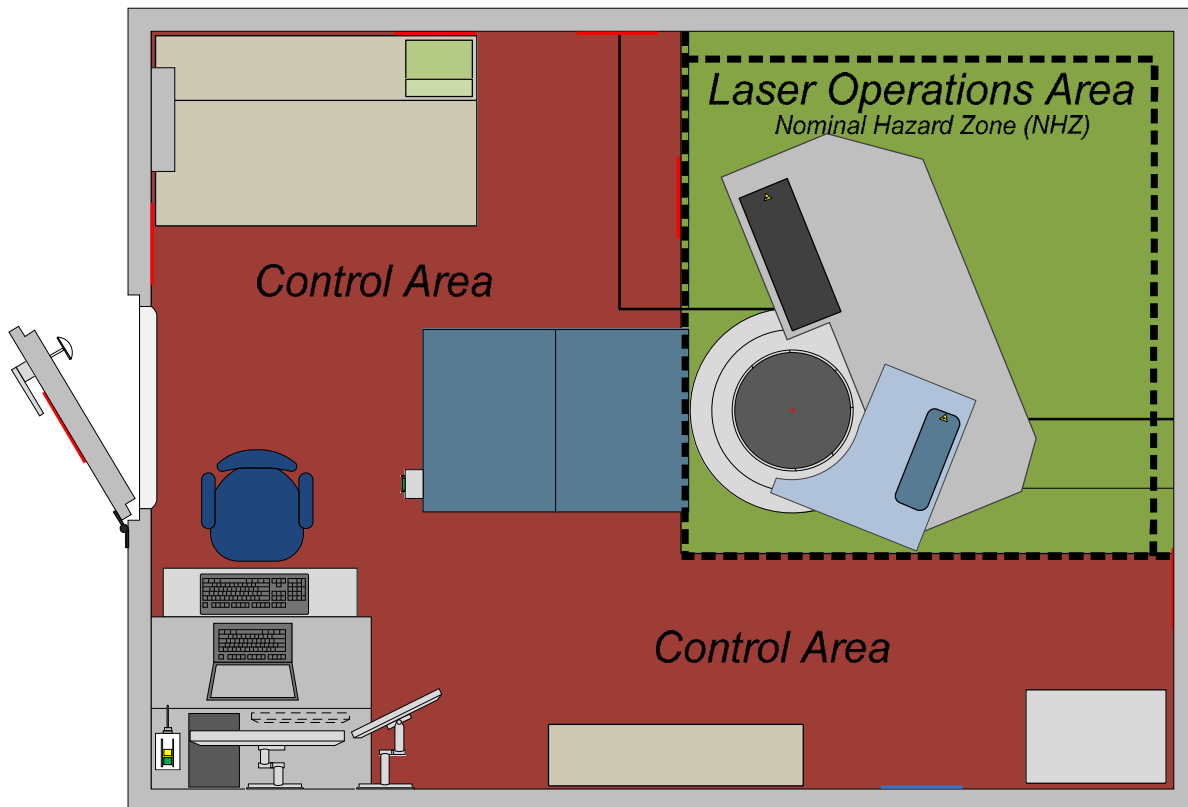

Figure 1-1: Illustration showing the location of the Laser Operations Area

1.4 Laser Safety Requirements



Warning: The laser(s) can pose a serious visual hazard if proper precautions are not observed. You must understand and follow the precautions listed in the NGSLR Safety Plan and in this manual to ensure safe operation. Failure to follow these guidelines can result in severe eye damage to anyone exposed to the beam.

1. The NGSLR shelter **must** be locked when maintenance, development or operational efforts are not taking place.
2. A **certified laser user must** be present and is the only person that can operate the laser.
3. A **certified operator must** be present for operations at NGSLR.
4. The operator **must** contact the FAA at least 2 hours prior to the first pass of the week to notify them of weekly operations, upon commencement of the first pass for the week, and upon conclusion of the last pass of the week.
5. Because the laser is **not** eye-safe, the aircraft avoidance radar (LHRS) **must** be used (on and engaged) whenever the system is ranging with the dome shutter open.
6. The operator **must** verify that the safety chain (and sign) on the stairs is in place, blocking access to the roof. Under no circumstances should anyone be allowed to be on top of the shelter when the laser is operational.
7. The NGSLR Shelter door **must** be closed, and the laser warning light **must** be on anytime the laser is operated.
8. The black laser safety curtains **must** be pulled completely closed when the laser is ON.
9. Only certified laser users are allowed in the laser operations area whenever the laser is firing.
10. Laser users are **required** to wear laser safety goggles when they are behind the laser safety curtain with the laser firing. The OD level of the goggles **must** match the laser and its power level as specified in this manual. Refer to the sign posted on the wall for the laser energy output and the required OD.
11. The laser is **never** considered eye-safe on the laser table, regardless of the power level.
12. The operator should be ready to use the laser *Disable* button to manually disable the laser if at any time the health, safety of persons and/or property is at risk.
13. The operator **must** watch the telescope mount camera monitor to ensure that aircraft do not enter the aircraft avoidance region (represented by a circle on the monitor) during tracking or that personnel are not near the calibration pier during ground calibration.

Think Safety First!

2 Operations Requirements and Emergency Procedures

2.1 Operational Considerations

As automation of the system is under development, the operator still plays an important role in the operation of the station. The operator is present to re-enable the laser after an aircraft detect (per FAA requirements), as well to adjust various pieces of equipment that have not yet been automated, including closing the dome before inclement weather strikes.

2.1.1 Description of basic ranging operations

Once the system has been powered on and configured for ranging operations, the operator will cycle back and forth between ground calibrations (that aid in maintaining system accuracy) and tracking sets of scheduled passes. Each scheduled set of passes lasts from 1-1 ½ hours, and consists of satellites in a variety of orbital paths and altitudes. Any single pass could last from 2 minutes up to 1 hour. Regardless of the satellite, these are never tracked below 20° in elevation due to laser safety concerns. Opening and closing of the shelter door should be kept to a minimum during passes, as this can affect the quality of the data collected.

Every pass attempt should be entered into a log sheet that is filled out during every shift, with a new log sheet used for each shift. You are required to fill in the requested information on the log (see Appendix B) and note all error conditions and other anomalies that occur during the shift.

At the end of the shift, the operator must make sure that all necessary equipment is off (especially the laser), that the dome is completely closed, and that the shelter is locked.

Outline of Typical Shift:

Power up system	
	Initial Ground Calibration
	Set of Satellite Passes
	Ground Calibration
	Set of Satellite Passes
	Ground Calibration
	Set of Satellite Passes
	Ground Calibration
	Set of Satellite Passes
	Ground Calibration
	Set of Satellite Passes
	Ground Calibration
	Set of Satellite Passes
	Final Ground Calibration
Shut Down System	

2.1.2 Reasons to stop tracking

Laser Ranging occurs for scheduled passes as cloud conditions and ILRS restricted tracking parameters[†] permit. Exceptions include the following conditions where the dome must be closed in order to protect sensitive equipment:

1. Precipitation of any kind
2. Sustained gusts of greater than 40 mph (17.8 m/s)
3. Temperatures that are above 122° F (50° C) or below 14° F (-10° C)*

** If you are in the middle of a pass and the temperature drops below the lower limit during the pass, you may complete the pass before shutting down.*

[†] Some missions define whether they will allow satellite tracking at a particular time. See the ILRS website for more information on tracking restrictions at: <http://ilrs.gsfc.nasa.gov>

2.1.3 System Readiness

Depending upon past tracking performance (both NGSLR and LRO), a decision must be made as to whether any system alignment procedures or checks need to be performed.

Three levels of tracking readiness can be identified for tracking operations, they include:

1. **SLR tracking operations are successful in previous attempts and no changes have been made** – The system is tracking successfully (with or without pointing bias), and no additional alignment checks are needed. Attempt tracking operations.
2. **Previous SLR tracking engagements have been unsuccessful for unknown reasons** – Attempt tracking, noting any unusual biases, system errors, or hardware anomalies on the log sheet. Immediately stop tracking should a safety related failure occur.
3. **Maintenance, alignment, and or development work is required to bring the system up to full tracking readiness** – Tracking is not possible in this state. This may include laser or equipment replacement, timing or star calibration issues, or equipment failure.

2.1.4 Equipment to be left running



Warning: The following equipment should never be turned off!

- | | |
|---|-----------------------------------|
| • GPS Time and Frequency Receiver (XL-DC) | • Range Gate Generator (RGG) |
| • Computer Clock Sync Interface (CCSI) | • Constant Fraction Discriminator |
| • Cesium Frequency Standard | • The NIM Crate |
| • Event Timer (ET) | • Power Distribution Box |

There are certain devices and equipment that should *never* be turned off except in the case of an emergency such as fire, water leaking through the roof, etc. This ensures that accurate timing is maintained. All timing sensitive equipment will have a yellow warning label as shown below:

Warning: Do not turn off this equipment!

2.1.5 Temperature stability inside the shelter

Due to the fact that the equipment within NGSLR requires a narrow range of temperatures to operate, do not adjust or otherwise change the settings on the thermostat.

2.1.6 Coordination with other onsite Space Geodesy techniques

NGSLR shares the Goddard Geophysical and Astronomical Observatory (GGAO) site with various other experiments, and must be able to operate without adversely affecting other projects. NGSLR may also be called upon to perform synchronous tracking with other co-located laser stations.

2.1.6.1 Radar interference prevention for VLBI

The VLBI project, co-located at GGAO, uses a radio telescope to record faint signals from distant radio sources. In order to protect the ultra-sensitive VLBI receiver from damage from the LHRS radar, a redundant set of pointing masks have been developed, preventing RF transmission in the direction of the VLBI antenna. The first mask is software based, and prevents the telescope (and the slaved LHRS radar) from pointing in the direction of the VLBI station. The second mask is installed in the LHRS system, and prevents the radar from transmitting if it were to ever point in the direction of the VLBI telescope.

2.2 LHRS/IOC Verification

The complete LHRS/IOC Verification Procedure should be performed on a quarterly basis, as well as any time the LHRS, IOC, or any of the associated hardware systems are modified or repaired. A subset of the LHRS/IOC Verification Procedure is performed on a weekly basis, to ensure the continued safe operation between the quarterly checks. The procedure is listed in NGSLR Safety Manual. Please note that there is a separate LHRS/IOC checklist for SLR and LRO operations.

2.3 Crew requirements for FAA compliance at NGSLR

The system's proximity to multiple airports in the Baltimore/Washington corridor requires that additional precautions be taken in regards to laser safety and aircraft. Because of this, the operator is required to call the *National Capitol Regional Coordination Center (NCRCC)* according to the following schedule:

- At least 2 hours prior to the first pass of the week to notify them of weekly operations
- Upon commencement of the first pass for the week
- Upon conclusion of the last pass of the week

Operations are to be conducted consistent with the operations times provided to the FAA, and should always be provided in Eastern Daylight or Eastern Standard Time. In addition, it is imperative that you record the name of the person you talked to at the FAA and record that contact information in the log book, along with the date and time. See the NGSLR Phone Number and Contact Sheet for the NCRCC Phone number.

Example Conversations for each contact with the FAA

Two Hours Prior - Call 2 hours before the first pass of the week. Say something similar to:

"This is Joe Smith at the Goddard Space Flight Center. I am calling to inform you that we will be commencing laser ranging operations today at [time] ending operations at [date/time]."

15 Minutes Before - Call 15 minutes before the first pass of the week. Say something similar to:

"This is Joe Smith at the Goddard Space Flight Center. I am calling to inform you that we are commencing laser ranging operations."

At the end of your Shift - Call at the end of operations for the week. Say something similar to:

"This is Joe Smith at the Goddard Space Flight Center. I am calling to inform you that we are ending laser operations for the week. Operations will begin again on [date/time]."

2.4 In Case of Improper Function of Laser Safety Equipment



IF THE OPERATION OF THE LHRS, IOC OR ANY ASSOCIATED SAFETY HARDWARE BECOMES SUSPECT, DO NOT CONTINUE TRACKING OPERATIONS!

In the event that the operation of safety hardware becomes suspect or malfunctions, IMMEDIATELY stop operations and contact the appropriate person (NASA SLR Lead, NASA SLR Manager or Lead Hardware Engineers) as directed on the Emergency Contact sheet posted on the inside of the shelter door.

***DO NOT CONTINUE OPERATIONS UNTIL GIVEN CONCURRENCE
BY EITHER THE NASA SLR LEAD OR NASA SLR MANAGER.***

2.5 In Case of Laser Hazard Event



IF YOU ENCOUNTER A LASER HAZARD EVENT, CEASE OPERATIONS AND CONTACT THE NASA SLR LEAD AND NASA SLR MANAGER IMMEDIATELY!

Any of the following constitutes a Laser Hazard Event:

- If the operator perceives that an aircraft entered the 2° inscribed circle on the telescope camera monitor, yet a laser disable did not occur
- If an aircraft is illuminated by the laser
- If personnel are injured by the laser in any way

Refer to Section 2.6.3 of this manual for the required procedure that covers these situations.

2.6 Emergency Procedures

In the event of an emergency, use the below information to help you properly deal with the situation.

2.6.1 Emergency Contact Information

Goddard Emergency/Rescue:

Removed (jlfm)

Site Address:

Removed (jlfm)

Non-Life Threatening Emergencies:

Removed (jlfm) *GSFC Help Desk for major problems such as loss of power or flooding (Open: 24 X 7)*

General Maintenance Issues: (non-emergency)

Removed (jlfm) *GSFC Help Desk for non-emergency problems (clogged toilets, lights burned out, etc)*

2.6.2 Injury/Imminent Danger to Personnel

If a hazardous condition is detected that is caused by equipment in the system, immediately perform an emergency power down of the equipment. If someone has been injured and/or there are people in imminent danger of injury, immediately warn all affected personnel and evacuate to a safe area. Once you are in a safe area, call the GSFC Emergency Console Operator by dialing **911**. Some typical conditions that require action include:

- Detection of flame, smoke, or other evidence of fire
- The spill of a highly toxic chemical
- Attempted access by unauthorized personnel

2.6.3 Laser Hazard Event / Close Calls

In the event of a close call or other event involving the laser or laser safety controls the operator shall:

1. ***Immediately STOP operations!***
2. ***Turn off the laser system***
3. Notify the NASA SLR Lead and the NASA SLR Manager
4. Quarantine the following:
 - a. Station hardware
 - b. System software
 - c. Operator's log book
 - d. Pass data for the laser and the radar
 - e. Current operating procedures used by the operations and engineering staff
 - f. Any other items identified by the NASA SLR Lead/Manager
5. The NASA SLR Lead will notify the Government project office
6. The operator is ***not to continue*** operations until given concurrence by the NASA SLR Lead/Manager

3 Preparing for Tracking Operations

3.1 Initial Preparations

1. **Fill out the Operations Log** – At the commencement of your shift, fill out the NGSLR Operations Log as shown in Appendix B. Make sure to keep this log sheet in a convenient place as you will continue to enter additional information with each pass / ground calibration that is performed.

If this is the first satellite track of the week, perform step #2, otherwise continue to step 3.

2. **Call the FAA** – Inform the FAA of pending operations immediately after beginning the operations log.
 - a. Call the FAA. (See the posting in the shelter for the current number)
 - b. Say something similar to:

“This is Joe Smith at the Goddard Space Flight Center. I am calling to inform you that we are commencing laser ranging operations.”

- c. Write down the name of person spoken to in the Operations Log, along with the current time.
3. **Verify that the LRO mirror has been removed** – If the 45° LRO transmit mirror is still in place, flip the lever to the OFF position and move the mount to a safe location off to the side (Figures 3-1 & 3-2). This optic is only used during LRO operations.



Figure 3-1: LRO Insertion Mirror

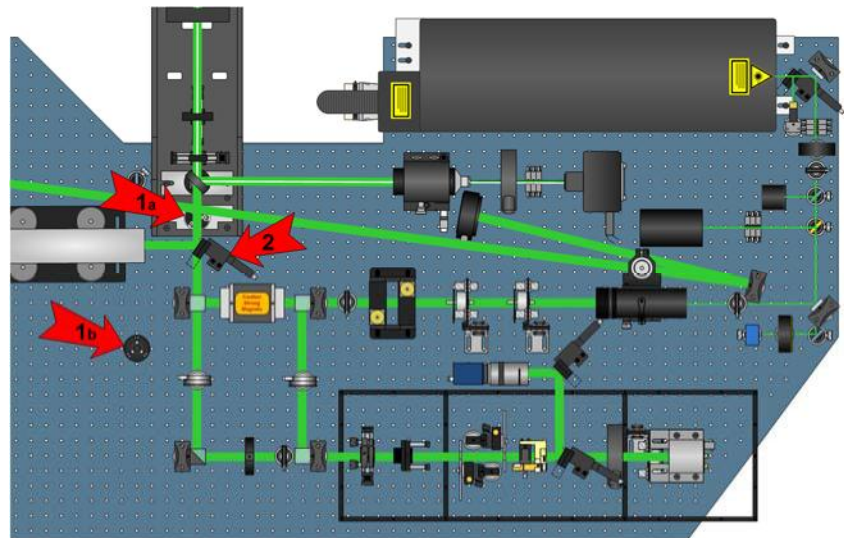

Figure 3-2: Diagram of the optical bench showing the operational location of the LRO Insertion Mirror [1a] and the storage location [1b]. The Autocollimator Turning mirror is shown on the right [2]

4. **Verify that the Autocollimator Turning mirror has been lowered** (Figure 3-2) – If necessary, use the controller mounted upside down on the telescope pier extension to drop the mirror below the beam height.

3.2 Power Up Sequence

1. **Power up each device in the rack in the order shown on Figure 3-3**

- 1) Servo (mount) controller: Main power
- 2) Servo (mount) controller: Control power

Note: Rightmost switch (AUX PWR) always stays OFF (down)

- 3) Turn the ICC computer ON – *(The ICC software starts automatically after booting)*
- 4) Dome shutter controller
- 5) Dome motor driver
- 6) Dome controller
- 7) NASA Radar Controller

Note: Special care must be taken not to cycle power on the equipment with a yellow warning label. These systems must remain running at all times and should not be disturbed!



Warning: The following equipment should never be turned off!*

- GPS Time and Frequency Receiver (XL-DC)
- Computer Clock Sync Interface (CCSI)
- Cesium Frequency Standard
- Event Timer (ET)
- Range Gate Generator (RGG)
- Constant Fraction Discriminator
- The NIM Crate
- Power Distribution Box

*Except in the case of an emergency that presents possible danger to personnel or equipment.

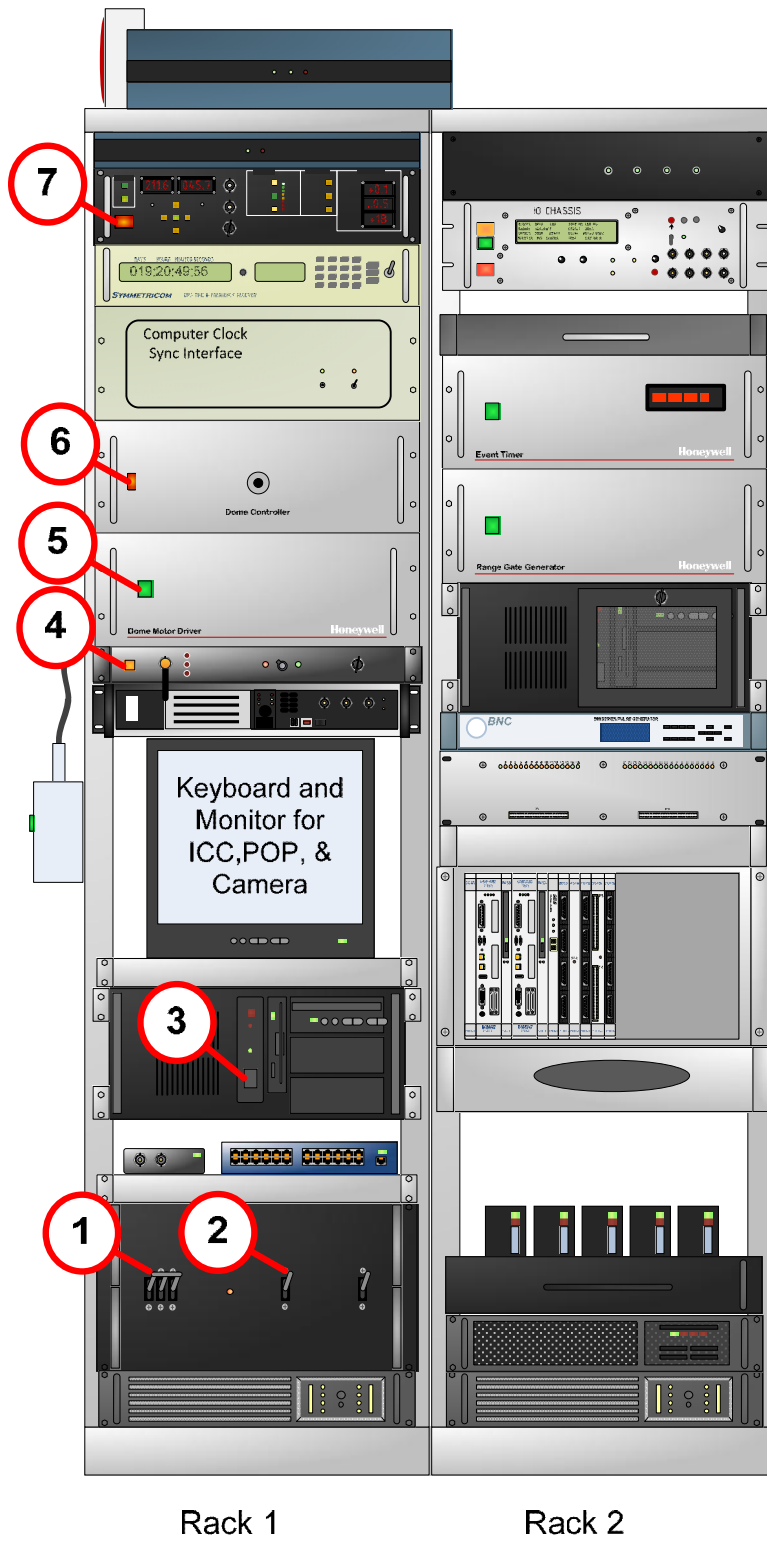

Figure 3-3: Power up sequence

2. **Open the Dome shutter** – To open the dome, rotate the SHUTTER switch to OPEN and then turn the key to ENABLE. The OPEN light will blink green until the dome is completely open, when the light will become solid. Go on to the next step while the shutter is opening.
3. **Ensure that the telescope camera and its monitor are ON** (Figure 3-4) – See Section 8.2 for more information on troubleshooting this system, if necessary.



Figure 3-4: Monitor for Telescope Camera

4. **Turn the RAT laptop on** – Press the power button on the laptop and go on to the next step while it is booting.
5. **Make sure the Camera computer is up and running** – Switch to the camera computer screen by selecting button #2 on the rack-mounted console (Figure 3-5). The camera computer should already be up and running. If not, press the power button as shown on Figure 3-6 to start the computer.



Figure 3-5: Rack mounted console

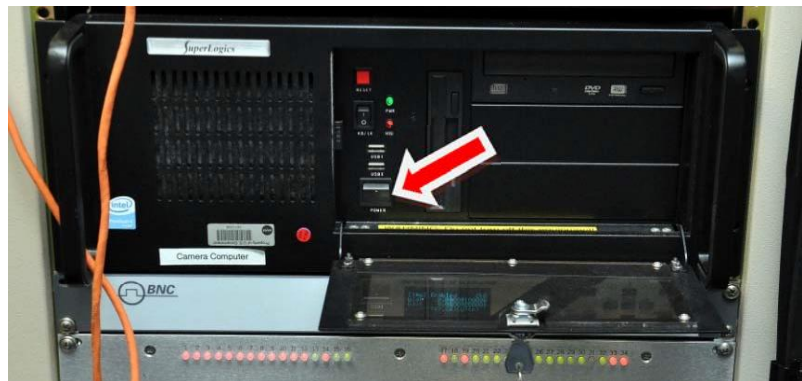

Figure 3-6: Camera Computer (Power button as indicated by arrow)

6. **Ensure that the NFS server is running on the Camera computer** – Double click the NFS server icon (shown at right). If the software is already running, a window should pop up and immediately disappear. However, if the window stays up, you will need to set up the NFS server so that the Camera computer can send and receive data (Figure 3-7). To set up the NFS server:
 - a. Select the **Show Icon on System Taskbar** checkbox.
 - b. Click on the **Hide** button.

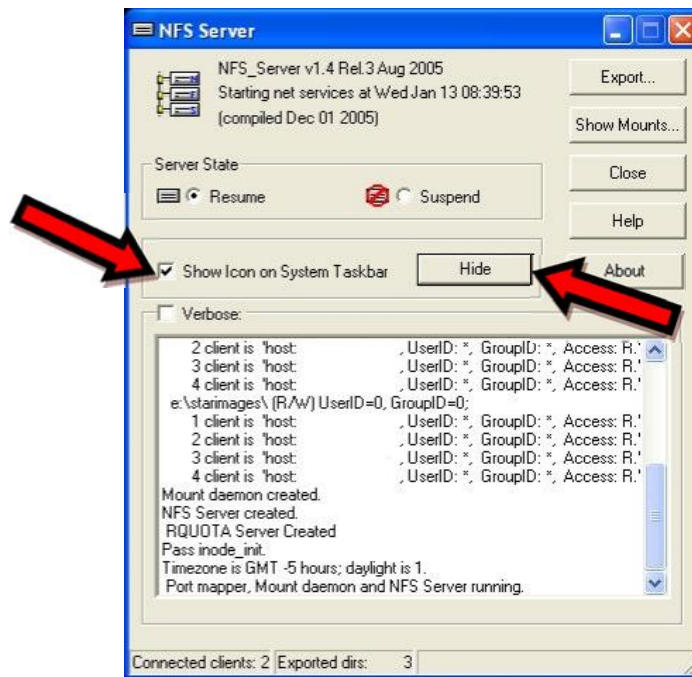

Figure 3-7: NFS Server Window

7. **Verify that the M: drive is mounted** – Double click on My Computer, then on the M: drive. A window should pop up indicating that the camera computer is able to mount the NFS share on POP (Figure 3-8). Close the window and continue to the next step.

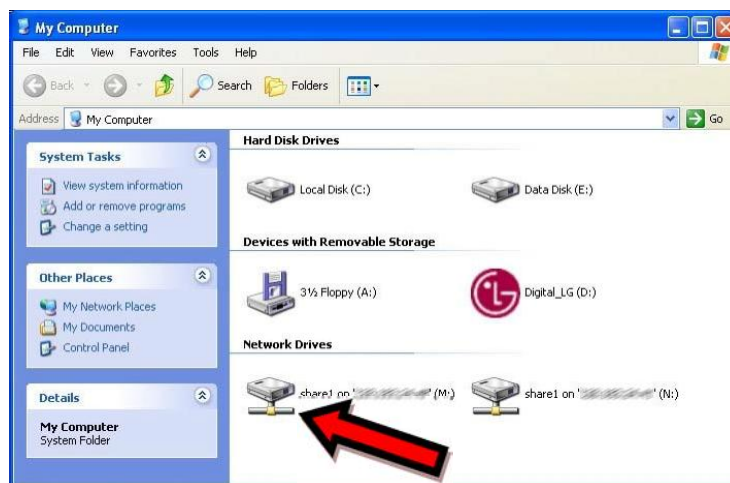

Figure 3-8: Screenshot of Drive Mappings

8. Ensure that the Sky Camera software is running in the background (minimized) – If the program is running, it will show up on the Windows XP taskbar (Figure 3-9). If it isn't running, click on the program icon (shown at right) to start the program .



Figure 3-9: Camera computer status bar showing that the Sky Camera Program is running

9. Once the Dome Shutter is fully open, turn the enable key back to the center position (pointing up).
10. Log into DAM at the DAM/POP terminal – To do this, go to Screen 2 by pressing ALT-F3. Look for the number [2] in the lower left corner of the display to indicate that you are on the right screen (Figure 3-10). Enter the username and password. DAM will begin the login process and start multiple programs that will run in the background.

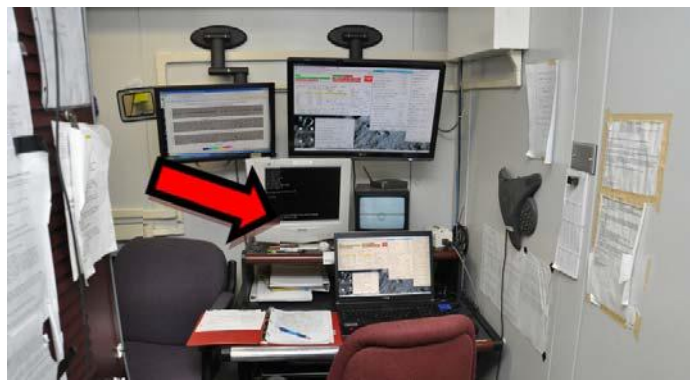

Figure 3-10: Console area showing the DAM/POP Terminal

11. Log into POP at the DAM/POP terminal – After all of DAM's programs have started, the password prompt for POP will show up on the same screen (Figure 3-10). Enter the POP password.
12. Log into the RAT laptop at the Operator Console using the *Technical User* account – The Ratgui software will automatically start, opening the user interface (Figure 3-11).

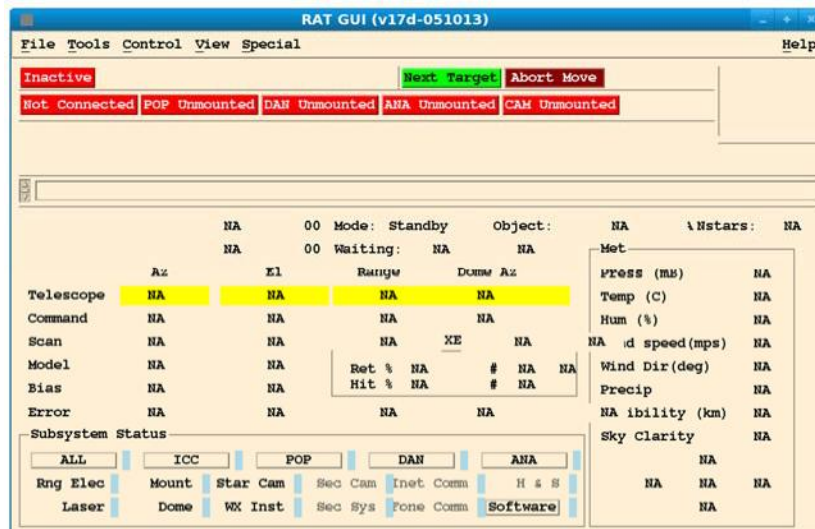

Figure 3-11: Main window for Ratgui as it appears after starting RAT

13. **Mount NFS Shares on RAT** – Click on each of the buttons in the RAT interface (as shown in Figure 3-12) to mount the NFS shares for DAM and POP. The buttons will change from red to green if the mount is successful.



Figure 3-12: Mounted and Un-mounted NFS Shares

14. **Connect to Ratsnest** – On the Ratgui window, select the Not Connected button (Figure 3-13). If the connection to Ratsnest is successful, the button will turn green and the label will change to Connected.



Figure 3-13: Not Connected / Connected Button

15. **Verify that Ratgui is actively controlling the system** – Verify that the button in the upper left hand corner of Ratgui shows that the system is active, not inactive. The top part of the interface now should look similar to Figure 3-14.

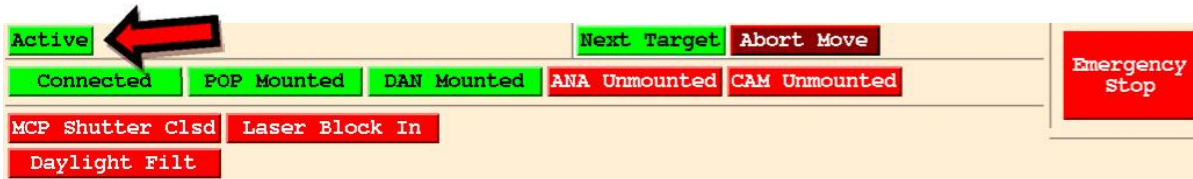

Figure 3-14: Ratgui Connected to Ratsnest and to the POP and DAM NFS shares

16. **Open the main Control Windows** – Open the **Control** windows, configuring each item as directed and leaving the window open. Do *not* click **Apply** on any of the windows *until* POP is started. You may move or resize the windows as necessary to allow access to all of these control windows.

a. **Control => Search**; Select the **Stop Search** checkbox (Figure 3-15).

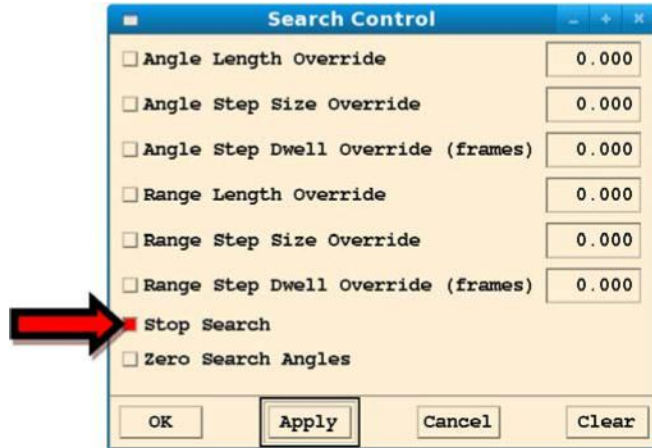

Figure 3-15: Search control window

b. **Control => Decisions**; Select the following checkboxes (Figure 3-16).

- **Do not use Quad Detector Biases**
- **Do not use Time Bias Solution**
- **Do not use Range Bias Solution**

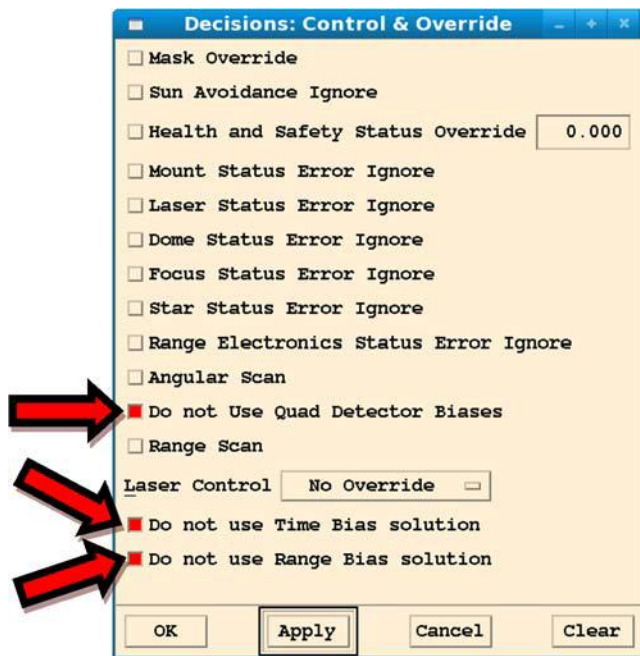

Figure 3-16: Decisions: Control & Override window

- c. **Control => Ranging;** Select the **No Star Assessment** checkbox (Figure 3-17).

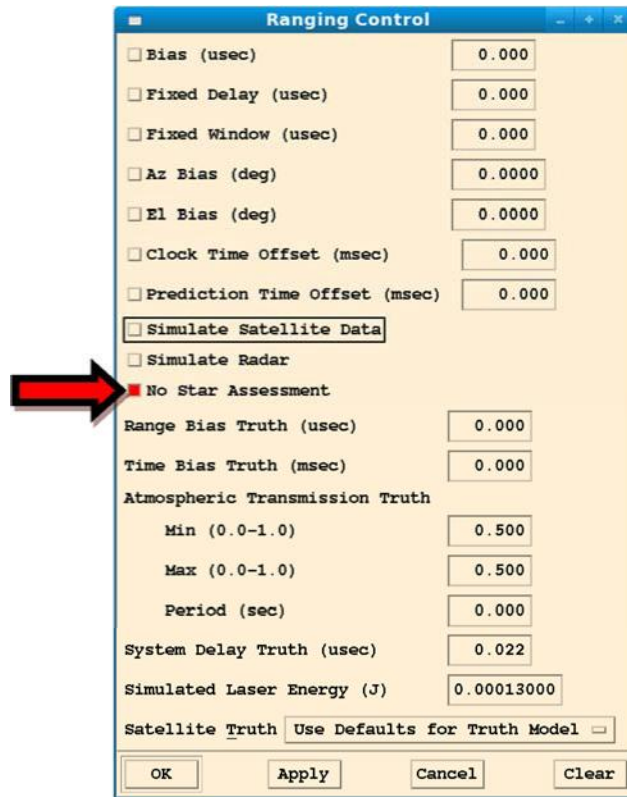

Figure 3-17: Ranging control window

d. **Control => Sensors;** Select all (6) **Sky Clarity** checkboxes (Figure 3-18).

Note: The below selections disable the use of the Sky Camera, as the cloud decision process is still undergoing development and testing. Once this is complete, it will no longer be necessary to disable this functionality.

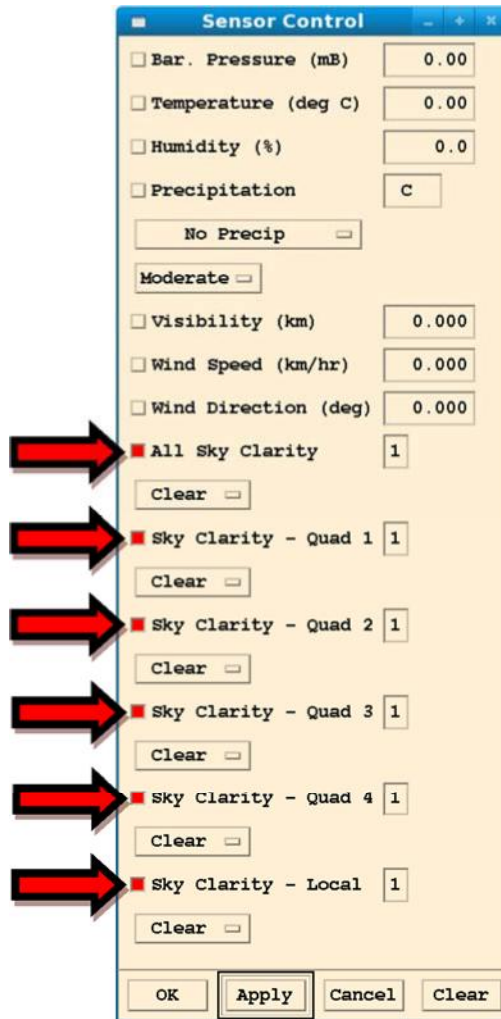

Figure 3-18: Sensor control window

3.3 Turning on supporting equipment

1. **Verify that the IO Chassis (IOC) is ON** – This is located at the top of the second rack (Figure 3-19). This is typically left ON.



Figure 3-19: IO Chassis (IOC)

2. **Turn ON the SLR Power Strip** – This supplies power to the PMT high voltage supply, the waveform generator, the high voltage amplifier, the power meter, and the gating module (Figure 3-20).

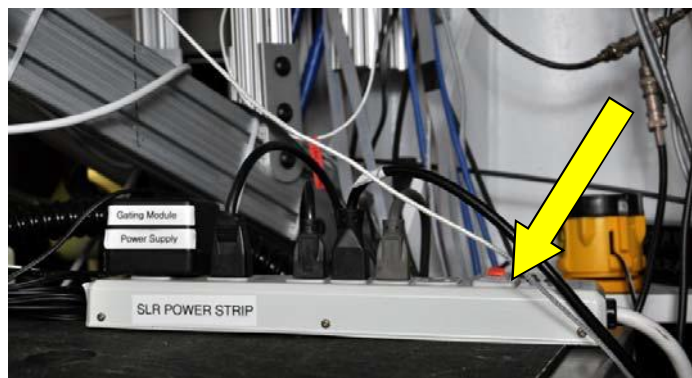

Figure 3-20: SLR Power Strip

3. **Verify that the waveform generator and the high voltage amplifier for the Liquid Crystal Optical Gates (LCOG) are ON** – These supporting devices can be found underneath the Optical Bench (Figure 3-21).



Figure 3-21: Waveform Generator and the High Voltage Amplifier

4. **Verify that the waveform generator is set to use waveform #1** – Select the **WVFM** button, then use the Down Arrow to display the current setting on the LCD screen (Figure 3-22).



Figure 3-22: Adjusting the Waveform Generator

5. **Turn the overhead lights OFF in the back area** – To prevent damage to the PMT, the lights *must remain OFF* whenever the Bertran high voltage power supply is turned ON.



Warning: *The lights in the Laser Operations Area must be OFF before proceeding to the next step! Permanent damage to the PMT could result.*



Warning: *Do not exceed the maximum voltage, or increase the voltage too quickly. Permanent damage to the PMT could result.*

6. **Power ON the Bertran high voltage power supply** – Supplying power to the PMT, this device is located under the Optical Bench (Figure 3-23).
 - a. Flip the **ON/OFF** toggle switch located on the left hand side to the ON position.
 - b. Slowly ramp up the operating voltage in 500 volt increments from -450 to -2950 volts over the span of 1 minute.
 - c. The MCP should be powered on for 20-30 minutes before any data is taken.



Figure 3-23: Bertran High Voltage Power Supply

7. **Slide the protective card in front of the light tight box to the UNBLOCKED position** – This is in place as a manual backup to the shutter, but must be removed before tracking.

3.4 Safety protocol prior to turning on the SLR laser

1. **Ensure that the stairway chain and warning sign are in place on the ladder** – This is to prevent unauthorized access to the roof deck (Figure 3-24).



Figure 3-24: Stairway chain and warning sign



Figure 3-25: Water gauge on the SLR laser chiller

2. **Ensure that the front door to the shelter is closed**
3. **Check the water gauge on the front of the chiller to ensure that it has sufficient coolant** (Figure 3-25)
4. **Verify that coolant hoses are properly connected to the laser system** – Ensure that the hoses are connected and that there is no leakage of coolant from the laser controller, chiller, or the laser head (Figures 3-26 & 3-27).



Figure 3-26: Coolant hoses for the Chiller and Controller

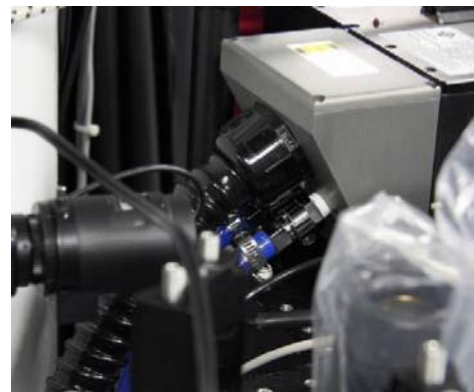

Figure 3-27: Coolant hoses for the Laser Head

5. **Ensure that the alignment flip mirrors are out of the beam path**
6. **Close the laser curtain, ensuring that both entrances are fully closed**
7. **Turn on the lighted Laser Warning sign** (Figure 3-28)



Figure 3-28: Laser Warning sign

3.5 Powering up and starting the SLR Laser Controller



Warning: Do not perform the below steps without having completed the steps listed in the previous section. Make sure to inform all present prior to activating the laser. Failure to follow these guidelines can result in eye damage to anyone exposed to the beam.

1. **Turn ON the laser controller**

- a. Flip On/Off red rocker switch labeled **Power** on the laser driver to the ON position (Figure 3-29). Verify that the chiller pump is running (motor should be audible).
- b. Turn Laser Enable key to **ON** position (Figure 3-29).



Figure 3-29: Front Panel of the Laser Controller

- c. Exit the laser operations area, closing the laser curtain behind you.

2. **Start the SLR Laser using the control software on the Camera computer**

- a. Click on the icon for the SLR Laser Control software (Figure 3-30). This will open two windows as shown on Figure 3-31.



Figure 3-30: SLR Laser Control icon

Note: When the software is launched, two windows will appear: one that is the GUI interface for the laser and the other (with the black background) for the Python interpreter supporting it. Do not close the window with the black background; closing it will close the GUI as well.

- b. **Select the STARTUP button** (Figure 3-31)

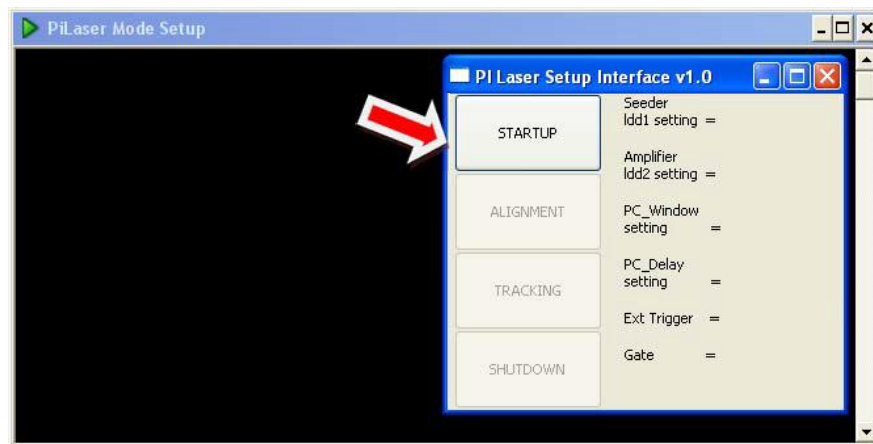

Figure 3-31: PI Laser Interface prior to starting the laser



Warning: Inform all present that the laser is being turned on. Make sure to close the laser curtain and that any personnel behind the laser curtain are wearing protective eyewear *before* turning on the laser. Minimum eyewear optical density for the SLR laser at tracking power is >4.7 ND @ 532nm. Failure to follow these guidelines can result in severe eye damage to anyone exposed to the beam.

- c. **Once the STARTUP button has turned dark green, click on the TRACKING button** (Figure 3-32). It will light up with a bright green color when the laser is ready to begin tracking.

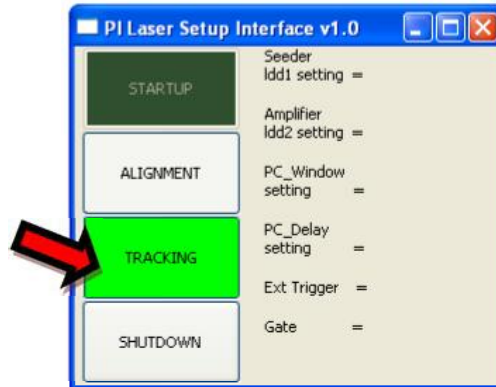

Figure 3-32: PI Laser interface showing that the laser in tracking mode

Note: The laser will not actually begin firing until the software is running and the laser has been enabled through the IO Chassis.

4 Performing Tracking Operations

Normal operation of the system includes alternating ground calibration and satellite passes. Careful attention must be paid to each step in this manual in order to ensure safe and efficient operation of the system and the continued collection of high quality scientific data.

All passes and ground calibrations should be recorded on the NGSLR Operations Log Sheet. See the example log sheet in the appendix for details on specific sections that should be filled out. Any problems, configuration changes, or other notable events that occurred during the shift should be recorded, along with the date and time, at the end of the log sheet. This can serve as an essential troubleshooting tool for the NGSLR development staff in tracking down the problem. In addition, please remember that each shift should start and end with a ground calibration that may or may not be set in the schedule. It is the operator's responsibility to ensure that these calibrations are performed.

During operations, the operator should remain alert regarding precipitation, temperature, and wind speed outside the normal operating range as defined in Section 2.1.2. The dome **MUST** be closed immediately whenever precipitation is imminent, or whenever wind gusts are above 40 mph (~17.8 m/s). Operations should not continue if the temperature falls outside of the normal operating range. However, if the temperature drops below the lower limit *during* the pass, you may complete the pass before shutting down. During both tracking and ground calibration, the operator should refrain from opening and closing the door as this will affect data quality. Never operate with the door open due to laser safety concerns and the possibility of reduced data quality due to temperature fluctuation.

4.1 Ground Calibration

Ground calibration is a technique to measure the station system delay (the difference between the theoretical time it should take for light to travel through the atmosphere in the horizontal path to the target and back, and the time that is actually measured by the system). Range measurements to satellite targets need to have this delay time removed to produce an accurate product.

Note: This section assumes that all equipment and software are running and configured as defined in Section 3.

Things to check for: LRO insertion mirror removed, LHRS ON, Autocollimator mirror retracted, PMT manual block removed

1. **Ensure that the MCP has been powered up for 20-30 minutes to achieve good data stability**
2. **Run POP** – At the DAM/POP terminal (screen #2), start the operational software by typing:

```
/prod/bin/pop -I <ENTER>
```

Note: Be sure to start the POP software on the "top" part of the minute (between 5 and 25 seconds into the minute) as listed on the GPS Time and Frequency Receiver. POP can potentially crash if it is started too close to the rollover of the minute, which will result in a long reboot (~15 minutes).

3. **Click the Apply buttons on all of the RAT control menus** – This sends the operator override settings to the DAM/POP software.

4. **Verify Weather Measurements** – Ensure that the meteorological data displayed accurately reflects current weather conditions outside the shelter (Figure 4-1). Note that if the values for Sky Clarity are NA, then most likely the Sky Camera software on the Camera computer is not running.

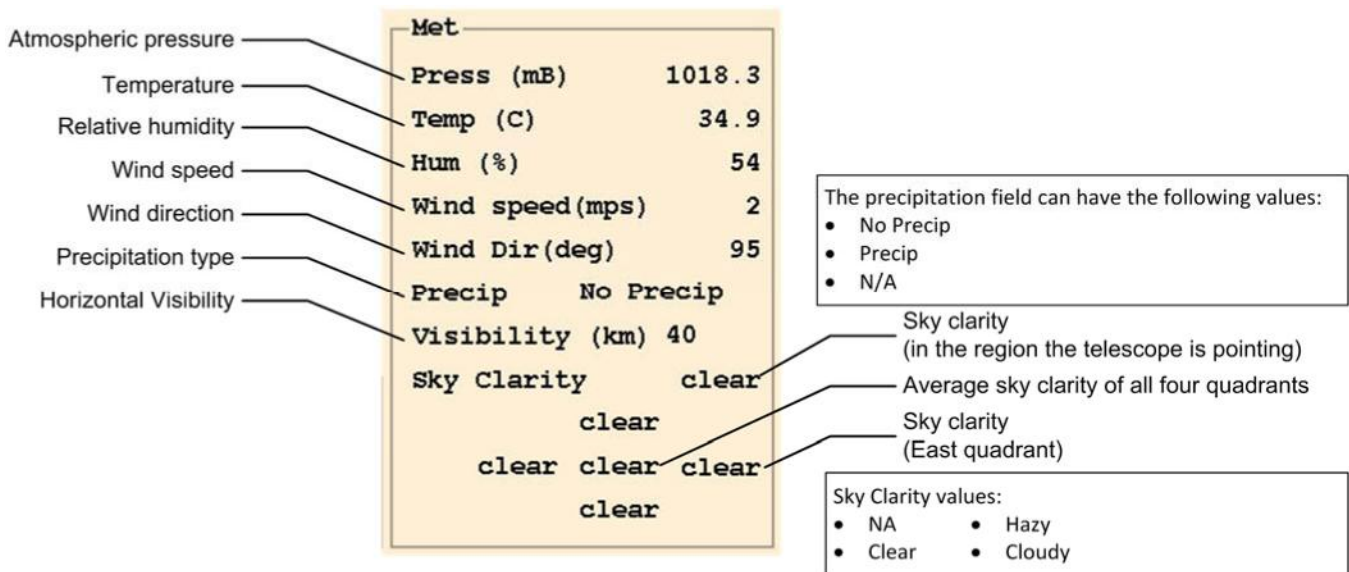

Figure 4-1: Labeled diagram of a portion of the Ratgui main window showing weather information

5. **Open the Schedule window and configure for Ground Calibration**

- a. Go to the Control menu and select Schedule (Figure 4-2).
- b. Turn Override Schedule button ON (Figure 4-3).
- c. Open the What to Do pull down menu and select Ground Calibration Without End (Figure 4-3).
- d. Open the Cal Targets pull down menu and select the C target (Figure 4-3).

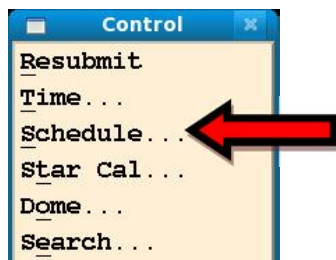

Figure 4-2: The top portion of the Control Menu

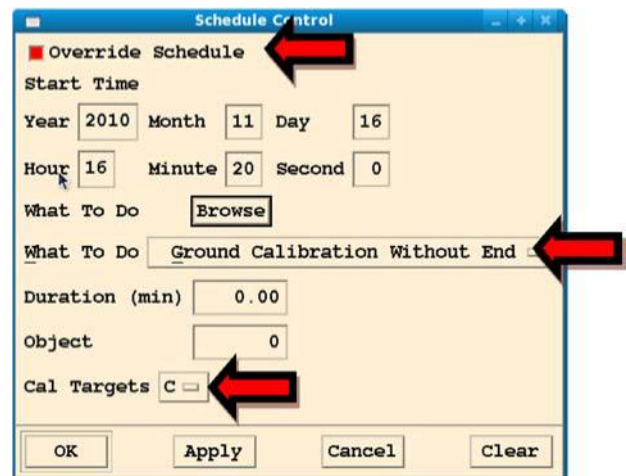

Figure 4-3: Schedule control window

6. Turn off Data Logging – Open *Control* => *Misc*, go to *Data Logging* and set to *Nothing* (Figure 4-4).

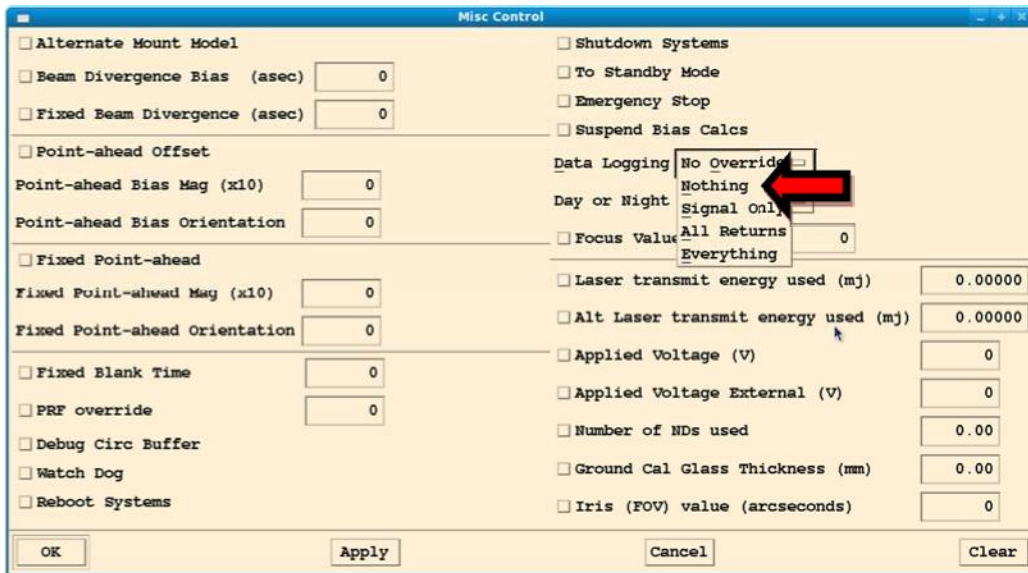

Figure 4-4: Misc Control menu

7. Apply changes to RAT – Select **Apply** on the Schedule and Misc Menus. This will apply the configuration settings without closing the window.
8. Ensure the area is clear around the calibration pier – Use the Mount Camera Monitor to ensure that personnel are not near the calibration pier. The operator is required to remain vigilant and verify that personnel do not enter the calibration area during the test.
9. Enable the Laser – Press the green **Enable** button on the **Enable Control Box** mounted on the side of the equipment rack (Figure 4-5). The 2 kHz beam block and ND insert will move out of place and the laser should begin to fire (Figure 4-6). If not, verify that **Laser Clear** button is depressed on the **Remote Beam Block Control Box**.



Figure 4-5 - Enable Control Box

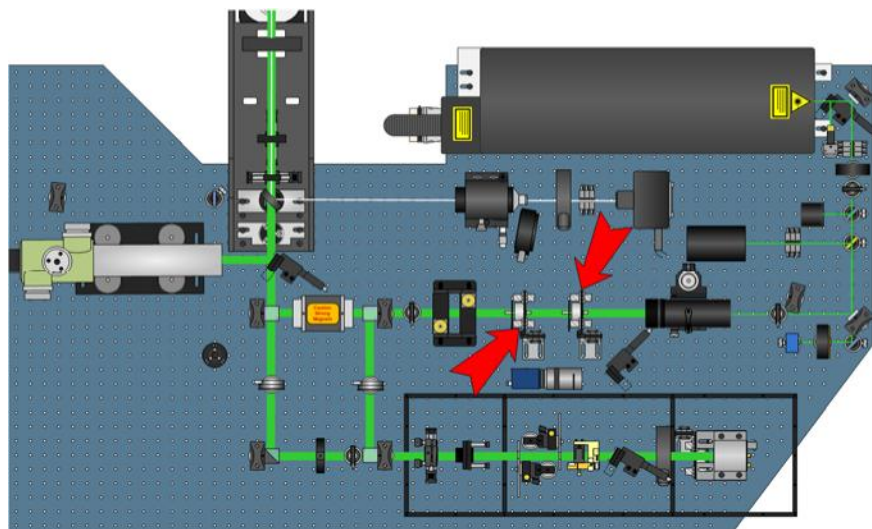

Figure 4-6: The location of the 2 kHz Beam Block & ND Insert on the Optical Bench

10. Make sure the laser is firing at the correct rate (approx. 2 kHz) – This should show up on the main RAT menu (Figure 4-7).

CPU Fri Feb 01 2013 (032) 18:18:46 Mode: Calibration Object:					
S2K 2013 (032) 18:18:54 Waiting: Yes					
	Az	El	Range	Dome Az	
Telescope	82.4750	-1.9100	0.0	80.9000	Open
Command	82.4750	-1.9100	1.1	82.4750	Open
Scan	0.0000	0.0000	0.0	XE 0.0	F 2000
Model	0.0140	-0.0800	Ret %116.90 # 2338 1		
Bias	0.0000	0.0000	Hit %108.95 # 2179		
Error	0.0000	0.0000	0.0	-1.5750	Sun 111.0

Figure 4-7: Ratgui main menu showing that the SLR laser is firing at 2 kHz

11. Open O-C Plot – Go to View => O-C Range Plot to graphically display the returns.
12. Open Quad Detector window – Go to View => Quad Detector menu to show the actual signal counts.
13. Verify that the system is receiving between 40 and 200 signal counts – Use the Quad Detector information window to view the signal counts from Quadrant 3 (Figure 4-8). If necessary, adjust the Number of ND’s used on the Misc Control window to achieve the appropriate number of returns.

Quadrant 1		Quadrant 2	
Signal (cts)	0	Signal (cts)	0
Noise (cts)	0	Noise (cts)	0
System Delay (us)	0.0220	System Delay (us)	0.1220
Quadrant 4		Quadrant 3	
Signal (cts)	0	Signal (cts)	94
Noise (cts)	0	Noise (cts)	9
System Delay (us)	0.3220	System Delay (us)	0.0548
Resulting Quad Biases		Combined Calibration	
Az Bias (deg)	NA	System Delay (us)	0.0200
El Bias (deg)	NA		
Close			

Figure 4-8: Quad Detector window

Adjusting the Rotary ND filters: The default number of ND’s applied by the rotary ND’s is 2.0. Look at the counts shown in Figure 4-8. If it isn’t in between 40 and 200, remove or add ND’s using the **Number of ND’s Used** entry in the **Misc Control** window to get the number of returns within an appropriate range (Figure 4-9).

<input type="checkbox"/> Alternate Mount Model	<input type="checkbox"/> Shutdown Systems
<input type="checkbox"/> Beam Divergence Bias (asec) 0	<input type="checkbox"/> To Standby Mode
<input type="checkbox"/> Fixed Beam Divergence (asec) 0	<input type="checkbox"/> Emergency Stop
<input type="checkbox"/> Point-ahead Offset	<input type="checkbox"/> Suspend Bias Calcs
Point-ahead Bias Mag (x10) 0	Data Logging <u>Nothing</u>
Point-ahead Bias Orientation 0	Day or Night <u>No Override</u>
<input type="checkbox"/> Fixed Point-ahead	<input type="checkbox"/> Focus Value (0.1mm) 0
Fixed Point-ahead Mag (x10) 0	<input type="checkbox"/> Laser transmit energy used (mj) 0.00000
Fixed Point-ahead Orientation 0	<input type="checkbox"/> Alt Laser transmit energy used (mj) 0.00000
<input type="checkbox"/> Fixed Blank Time 0	<input type="checkbox"/> Applied Voltage (V) 0
<input type="checkbox"/> PRF override 0	<input type="checkbox"/> Applied Voltage External (V) 0
<input type="checkbox"/> Debug Circ Buffer	<input checked="" type="checkbox"/> Number of NDs used 0.00
<input type="checkbox"/> Watch Dog	<input type="checkbox"/> Ground Cal Glass Thickness (mm) 0.00
<input type="checkbox"/> Reboot Systems	<input type="checkbox"/> Iris (FOV) value (arcseconds) 0
OK	Apply
	Cancel
	Clear

Figure 4-9: Changing the ND Value

- Begin to collect data** – Open the *Misc Control* window, go to *Data Logging*, select *All Returns*, and apply changes to begin collecting data (Figure 4-10).

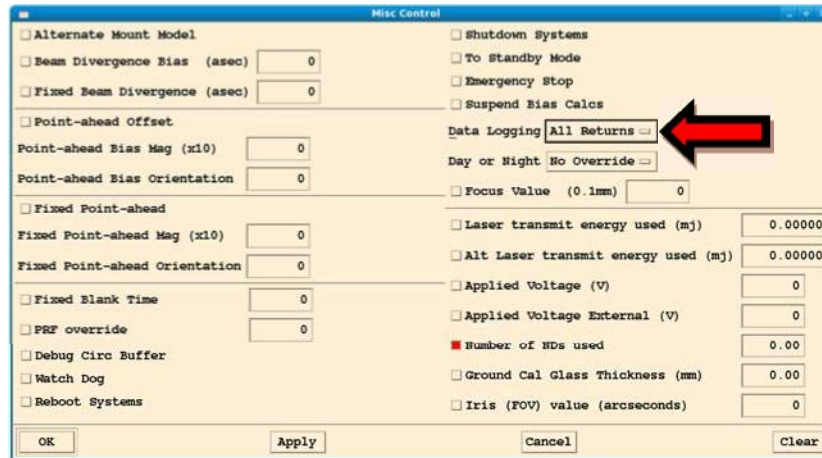

Figure 4-10: The Misc Control window showing All Returns selected

Note: The logging indicator on the lower left hand corner of the POP Screen should change from Log 0 (No Returns) to Log 2 (All Returns) indicating that the system is collecting data (Figure 4-11).

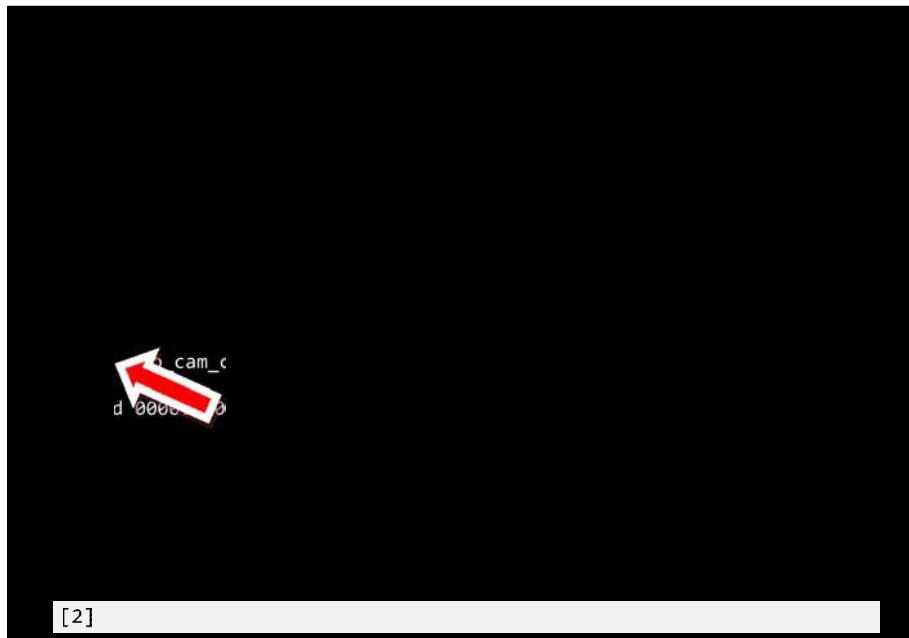

Figure 4-11: The POP Screen

- Collect data as directed** – Continue collecting returns for about five minutes. When this is completed, stop the POP software by going to the DAM/POP console (screen #2) and typing “x <ENTER>.”

4.2 Satellite Tracking Process

*This assumes that all equipment and software are running and configured as defined in Section 3.
 Things to check for: LRO insertion mirror removed, LHRS ON, Autocollimator mirror retracted, PMT manual block removed.*



Warning: During operations the operator should remain alert for precipitation and wind speed. The dome **MUST** be closed immediately whenever precipitation is imminent, or whenever wind gusts are above 40 mph.

1. **Ensure that the MCP has been powered up for 20-30 minutes to achieve good data stability**
2. **Run POP** – At the DAM/POP terminal (screen #2), start the operational software by typing:

```
/prod/bin/pop -I <ENTER>
```

Note: Be sure to start the POP software on the “top” part of the minute (between 5 and 25 seconds into the minute) as listed on the GPS Time and Frequency Receiver. POP can potentially crash if it is started too close to the rollover of the minute, which will result in a long reboot (~15 minutes).

3. **Hit all the Apply buttons on all of the RAT control menus** – This sends the operator override settings to the DAM/POP software.
4. **Verify Weather Measurements** – Ensure that the meteorological data displayed accurately reflects current weather conditions outside the shelter (Figure 4-12). Note that if the values for Sky Clarity are NA, then most likely the Sky Camera software on the Camera computer is not running.

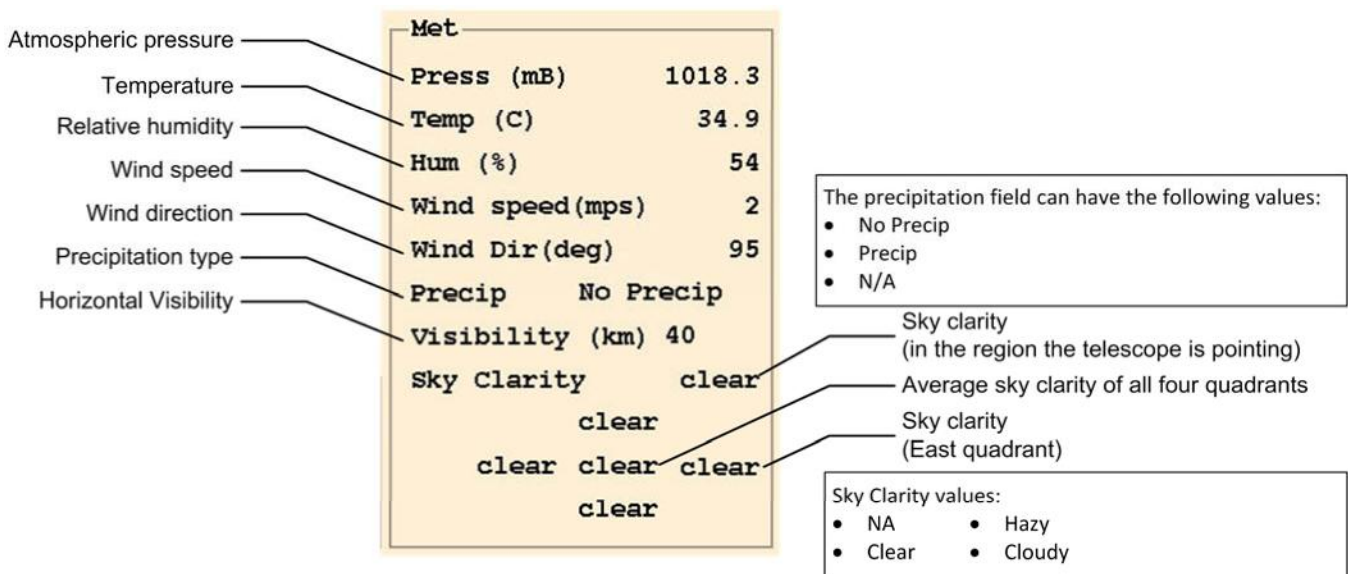

Figure 4-12: Labeled diagram of a portion of the Ratgui main window showing weather information

5. **Check the mount camera monitor** – The operator must watch the telescope mount camera monitor to ensure that aircraft do not enter the aircraft avoidance region (represented by a circle on the monitor) during tracking or that personnel are not near the calibration pier during ground calibration.

6. **Look for Two kHz Laser Blocked** – When the system is ready, the message “TwoKHz Laser BLOCKED” will flash on the POP screen (Figure 4-13).

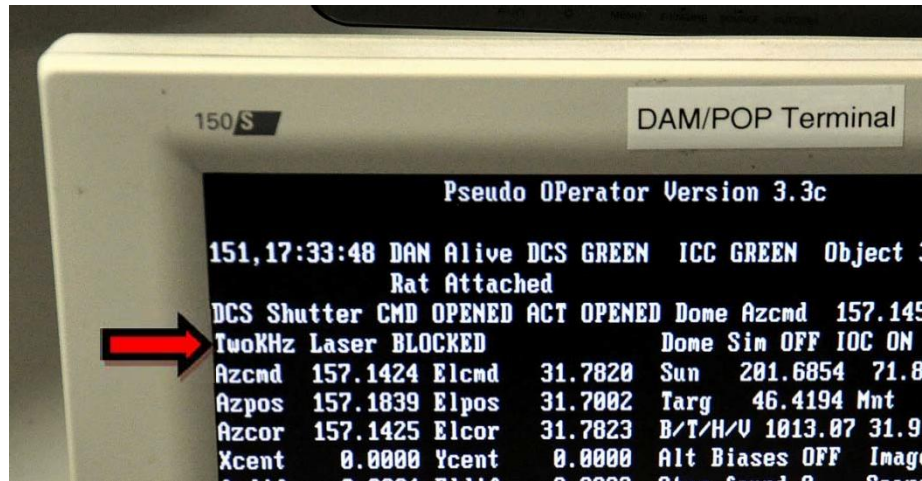

Figure 4-13: “TwoKHz Laser BLOCKED” message on the DAM/POP terminal

7. **Enable the Laser** – Press the green **Enable** button on the **Enable Control Box** mounted on the side of the equipment rack (Figure 4-14). The 2 kHz beam block and ND insert will move out of place and the laser should begin to fire (Figure 4-15). If not, verify that **Laser Clear** button is depressed on the **Remote Beam Block Control Box**.



Figure 4-14: Enable Control Box

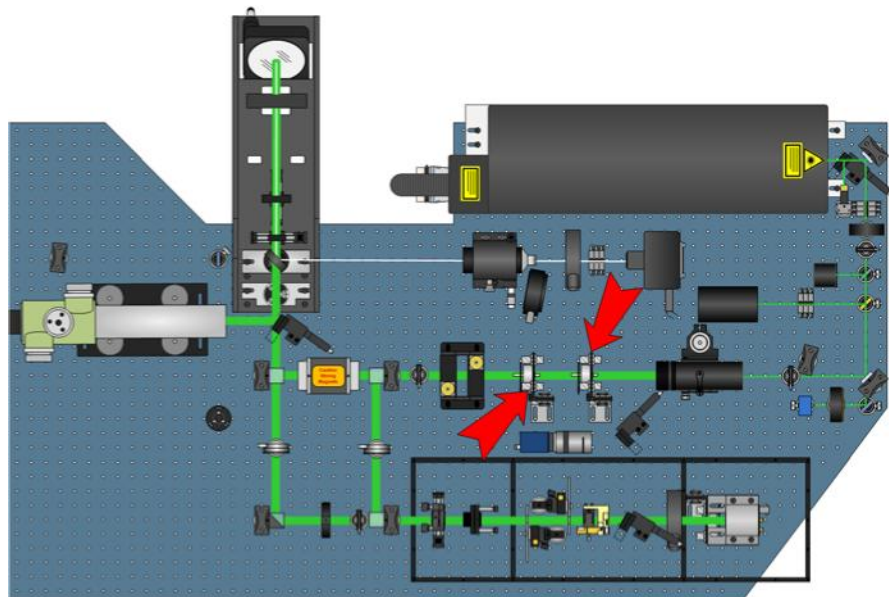

Figure 4-15: 2 kHz Beam Block & ND Insert

When the LHRS radar senses an aircraft getting close to the laser beam, it will immediately block the laser. When the aircraft detect is clear, the message “TwoKHz Laser BLOCKED” will flash on the POP screen (Figure 4-13). Check the camera monitor to ensure that the aircraft has passed, then push the ENABLE button on the Remote Laser Enable Control Box to re-enable the laser.

8. **Make sure the laser is firing at the correct rate** (approx. 2 kHz) – This should show up on the main RAT window (Figure 4-16).

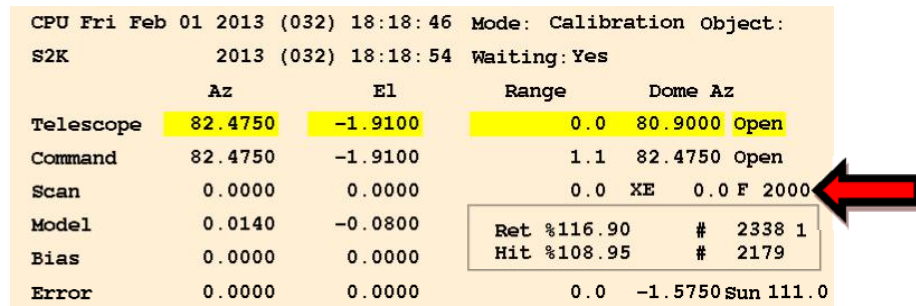

Figure 4-16: Section of the Ratgui main window showing that the SLR laser is firing at 2 kHz

9. **Verify that the system is receiving returns** – Go to *View => Realtime O-C Plot* (Figure 4-17).

There should be a single blue line showing the return signal, with the speckled haze across the window representing noise. See Section 8.6 for more details on what to do if returns are not detected.

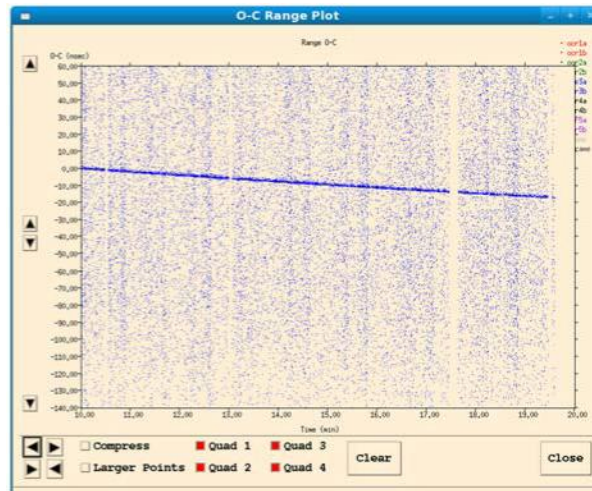

Figure 4-17: Real-time O-C Plot showing the detected return signals

10. **If necessary, adjust Azimuth and Elevation biases** – If return rate (signal counts) is low, or the target cannot be found, the pointing bias may need to be adjusted. Use one of the two following methods:
 - a. **Method 1: Use the Telescope bias window** – Open the window by going to *View => Az/El Handpaddle* and adjust Az/El Bias using the slider bars or by clicking in the window and selecting Apply (Figure 4-18).

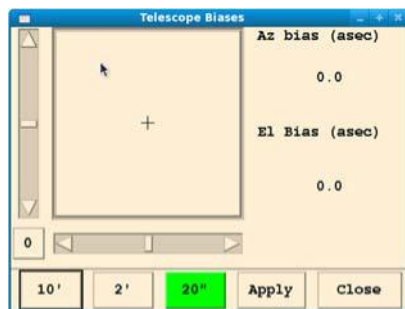

Figure 4-18: Telescope bias window (Az/El Handpaddle)

- b. **Method 2: Use the Ranging Control window** – Open the window by going to Control => Ranging, selecting the Az and El Bias radio buttons [left], entering the bias value desired [right], and applying the changes (Figure 4-19).

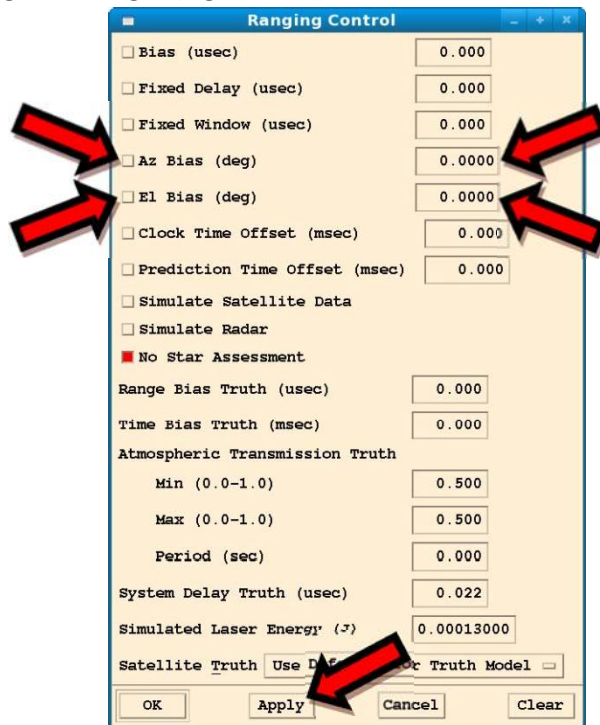

Figure 4-19: Ranging Control Window

- 11. **Record the pass information in the log** – Write down the satellite information in the NGSLR Operations log including the biases used to track the satellite, along with any anomalies in the system that were encountered.

Note: The system will automatically select the next target and begin tracking according to the priority assigned in the schedule. If tracking of a target is unsuccessful, the operator can click the **Next Target** button in the main Ratgui window to switch to the next target. Do not forget to fill out the Operation Log for the pass regardless of whether tracking was successful or not.

- 12. **Exit POP** – When the **set of passes** is over, type “x <ENTER>” at the DAM/POP terminal. POP will count down and then exit.

Note: If a ground calibration was not listed in the schedule, perform a ground calibration as listed in Section 4.1.

5 Routine Alignment Verification

The alignment of the mount throughout its range of motion must be routinely verified to ensure that the system biases remain current, whether due to alignment creep or a change in season.

5.1 Performing a Star Calibration

This section assumes that all equipment and software are running and configured as defined in Section 3. Things to check for: LRO insertion mirror removed, LHRS ON, Autocollimator Mirror Retracted, Star Camera ON, SLR & LRO Lasers OFF

The star calibration software calibrates the system using up to 50 stars to correct the pointing biases of the system, known as mount model coefficients. Weather conditions permitting, this process may be performed on a weekly basis, but no less than every few weeks. As the telescope will need to be able to capture the image of a star, star calibrations are only able to be performed at night. This procedure is automated and takes typically around 40 minutes to complete in a clear sky. It is wise to look at several stars after the calibration to make sure pointing is nominally 1 millidegree or less at ~45° elevation in all sky sectors.

5.1.1 Star Calibration Procedure

1. **Verify that the Dome shutter is open**
2. **Ensure that both the mount camera and its monitor are ON**
3. **Ensure that the Star Camera is turned ON** – Look for the red LED on the back of the device.

Note: The star camera must be turned ON prior to starting the software. Otherwise, the Star Camera program will enter simulation mode.

4. **Start the Star Camera software** – Go to the Camera computer and double click on the icon to start the software (shown on right). This should open up the star camera window (Figure 5-1).



StarCamera
03262009

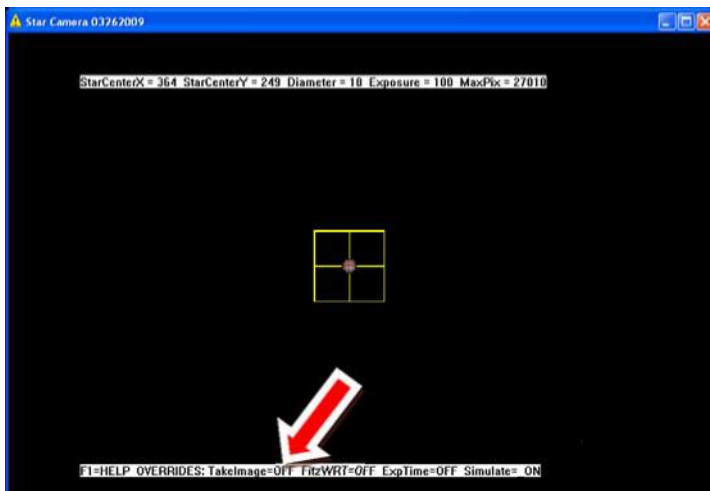

Figure 5-1: Star Camera Window

Note: The “Take Images” override (F2) should NEVER be turned on during a Star Calibration or Star Assessment since this will desynchronize POP and the Camera Software and potentially cause the Star Calibration or Star Assessment results to be worthless! See arrow on Figure 5-1 for location of status bar.

5. On RAT, open the *Schedule* window and configure for Star Calibration

- a. Go to the Control menu and select Schedule (Figure 5-2).



Figure 5-2: Control Menu

- b. Select the Override Schedule button (Figure 5-3).
- c. Open the What to Do pull down menu and select Star Calibration (Figure 5-3).

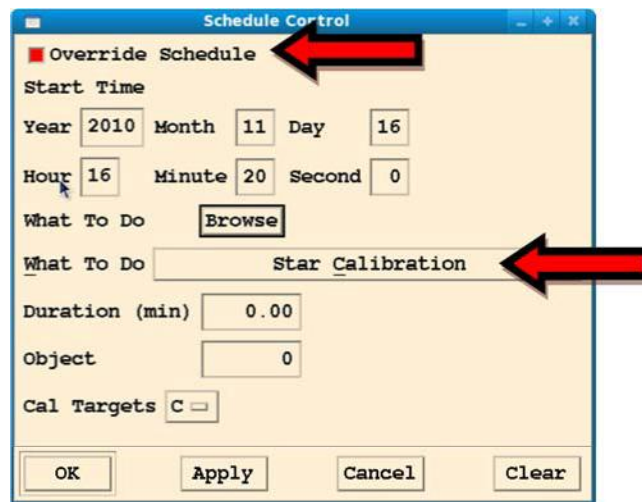

Figure 5-3: Schedule control window

6. Run POP – At the DAM/POP terminal (screen #2), start the operational software by typing:

```
/prod/bin/pop -I <ENTER>
```

Note: Be sure to start the POP software on the “top” part of the minute (between 5 and 25 seconds into the minute) as listed on the GPS Time and Frequency Receiver. POP can potentially crash if it is started too close to the rollover of the minute, which will result in a long reboot (~15 minutes).

7. **Apply changes to RAT** – Hit *Apply* on the Schedule Menu. This will apply the configuration settings and begin the Star Calibration. The telescope will move from star to star, center the image, then move to the next star. If the software cannot find a star after several attempts to capture the star image, the operator should use the **Next Star** button on the **Star Calibration** menu on RAT.
8. **Verify that the meteorological data is being logged properly** – Values for the pressure, temperature, wind speed, etc. should all be within normal ranges.
9. **Verify the RMS value** – Once the system has processed 50 stars, a series of windows will pop up. The last window that pops up will contain the RMS values of the Star Calibration. Scroll down in the window to view the calculated RMS value (Figure 5-4). If the solution is <3.5 RMS, the changes will be automatically applied to the mount model when the user exits POP, and will need to be verified as described in Section 5.2.2. Otherwise, the attempted Star Calibration will be rejected and will need to be re-run from the beginning of the procedure.

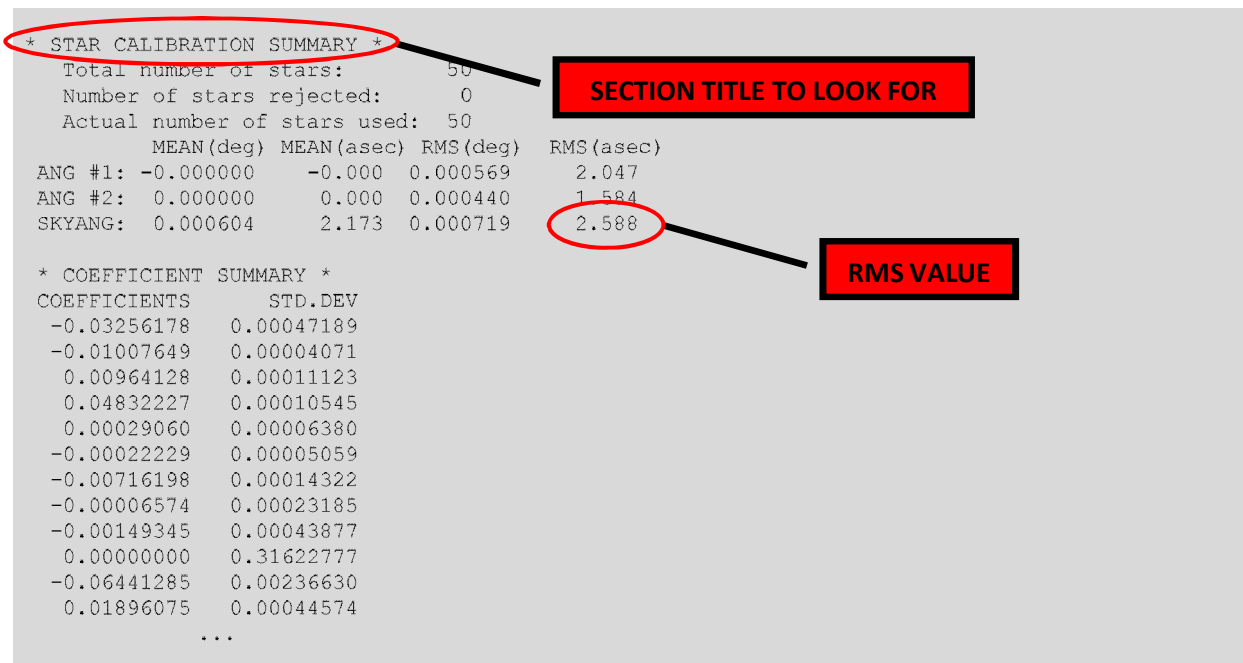

Figure 5-4: Location of the RMS Value in the Analysis File

10. **Stop POP** by typing “x <ENTER>” at the DAM/POP console

5.1.2 Verifying the Adjusted Pointing Biases produced by the Star Calibration

Note: This is a manual procedure which ensures that the telescope pointing remains accurate within a pre-determined range using the updated mount model. If not, a new automated Star Calibration will need to be performed.

1. **Set up another Star Calibration in the Schedule Control window**
 - a. Select the **Override Schedule** button (if not already selected). **DO NOT** select **Apply** yet.
 - b. Open the **What to Do** pull down menu and select **Star Calibration** (if not already selected) (Figure 5-5). **DO NOT** select **Apply** yet.

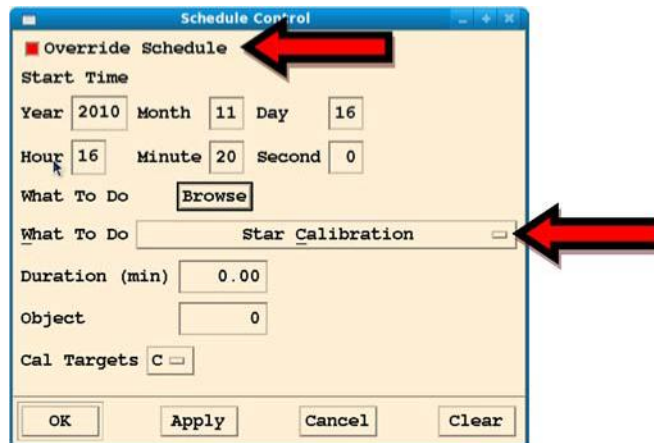

Figure 5-5: Schedule control window

2. **Configure the Star Cal Control window** – Go to **Control => Star Cal** control menu and select **Hold Star** (Figure 5-6). **DO NOT** select **Apply** yet.

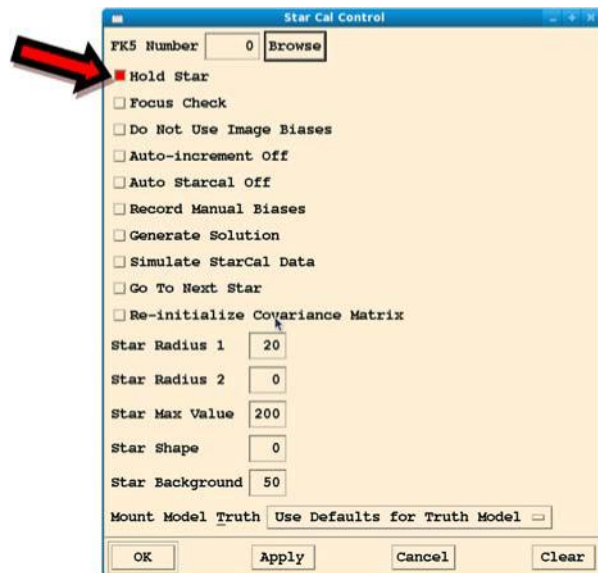

Figure 5-6: Star Cal control with Hold Star selected

11. **Run POP** – At the DAM/POP terminal (screen #2), start the operational software by typing:

```
/prod/bin/pop -I <ENTER>
```

Note: Be sure to start the POP software on the “top” part of the minute (between 5 and 25 seconds into the minute) as listed on the GPS Time and Frequency Receiver. POP can potentially crash if it is started too close to the rollover of the minute, which will result in a long reboot (~15 minutes).

3. **Apply changes to RAT** – Click Apply on both the Schedule and the Star Cal control windows.
4. **Open FK5 Lists** – Go to the Star Cal control window and click on the **Browse** button (Figure 5-9) – This will open a list of stars that are currently visible along with a graphical representation of their location (Figures 5-7 and 5-8). The radial lines on the plot represent the azimuth location of the star, and the circular lines represent the elevation of the star.
5. **Select a star that is near the 45° elevation mark in a particular quadrant** – This is performed using the point and click interface as shown in Figure 5-8.

Name	FK5#	Az	Zdis	Mag	RA (J2000)	Dec
11Bet Cas	2	22.3	74.9	2.27	+ 0: 9:10.70	+59: 8:59.2
17Zet Cas	17	21.8	81.3	3.66	+ 0:36:58.29	+53:53:48.9
18Alp Cas	21	20.0	79.3	2.23	+ 0:40:30.45	+56:32:14.5
27Gam Cas	32	16.2	76.5	1.60	+ 0:56:42.52	+60:43: 0.2
37Del Cas	48	13.0	78.4	2.68	+ 1:25:48.96	+60:14: 7.0
51 And	52	15.1	90.0	3.57	+ 1:37:59.56	+48:37:41.5
45Eps Cas	63	8.6	76.2	3.38	+ 1:54:23.71	+63:40:12.3
50 Cas	70	5.4	67.9	3.98	+ 2: 3:26.09	+72:25:16.7
15Eta Per	99	2.9	85.0	3.76	+ 2:50:41.81	+55:53:43.8

Brightest Magnitude: -2.0 Low Zenith Distance (deg): 90.0
 Faintest Magnitude: 4.0 Up Zenith Distance (deg): 0.0

Buttons: OK, Apply, Cancel

Figure 5-7: Table of FK5 stars

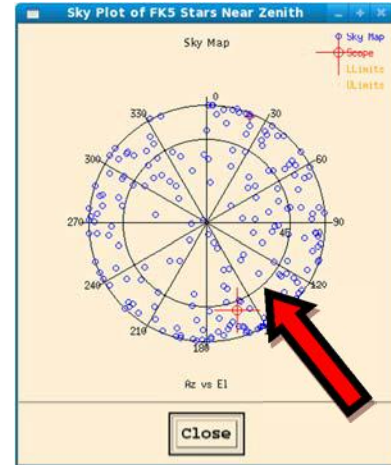

Figure 5-8: Map of FK5 stars

6. **Slew to the selected star** – Go to the Star Cal control window, de-select Hold Star, select Go to Next Star and click Apply (Figure 5-9).

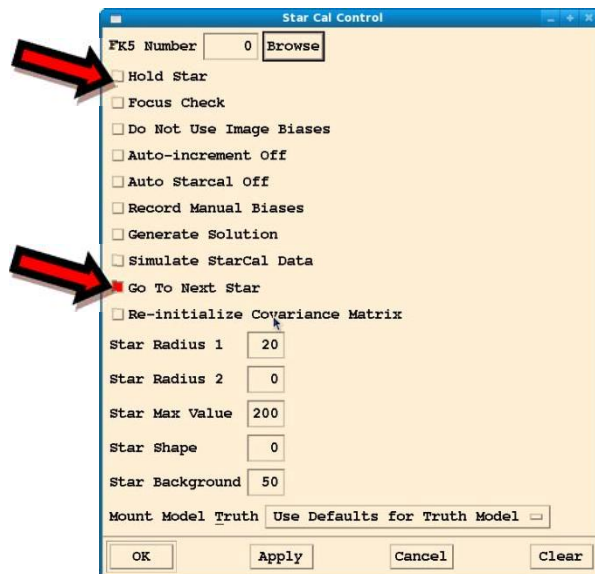

Figure 5-9: Section of the Star Cal control window

Note: The telescope should now be in the process of slewing to the next star. As it does, proceed to the next step to hold that position while the pointing biases for that star are verified.

7. **Hold the current star in position** – Go to **Control** => **Star Cal** control menu and select **Hold Star** (Figure 5-10). Wait to hit apply until you are on the star.

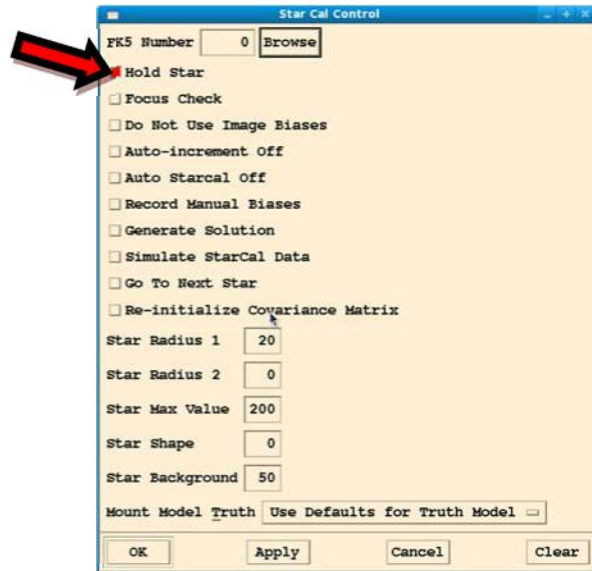

Figure 5-10: Star Cal control with Hold Star selected

8. **Verify that the Azimuth and Elevation Biases are within range** – After the software captures the image of the star and calculates the biases, check that the bias values are nominally 1 millidegree or less for each star observed during the verification procedure (Figure 5-11). If not, a second automated Star Calibration will need to be performed and the subsequent results verified.



Figure 5-11: Azimuth Bias (Abias) and Elevation Bias (Ebias) as shown on POP

9. **Step through at least one star in each quadrant of the sky to verify the Star Calibration** – Cycle between step 6 and step 9 to compare the pointing biases of the telescope to a star in each quadrant of the sky plot.
10. **Exit POP** – Go to the DAM/POP console (screen #2) and type “x <ENTER>.”

5.2 Performing a Star Assessment

This section assumes that all equipment and software are running and configured as defined in Section 3. Things to check for: LRO insertion mirror removed, Autocollimator Mirror Retracted, Star Camera ON

Star assessments may be done at the beginning of a satellite pass and allow the telescope to align with a star near to the beginning of the satellite pass in order to obtain azimuth and elevation biases to apply to the upcoming satellite pass. As the telescope will need to be able to capture the image of a star, star assessments are only able to be performed at night and require the use of the star camera.

To perform a Star Assessment, the procedure is the same as the steps used for Satellite Tracking, with the exception of the setup of the Ranging control window as shown below (Figure 5-12).

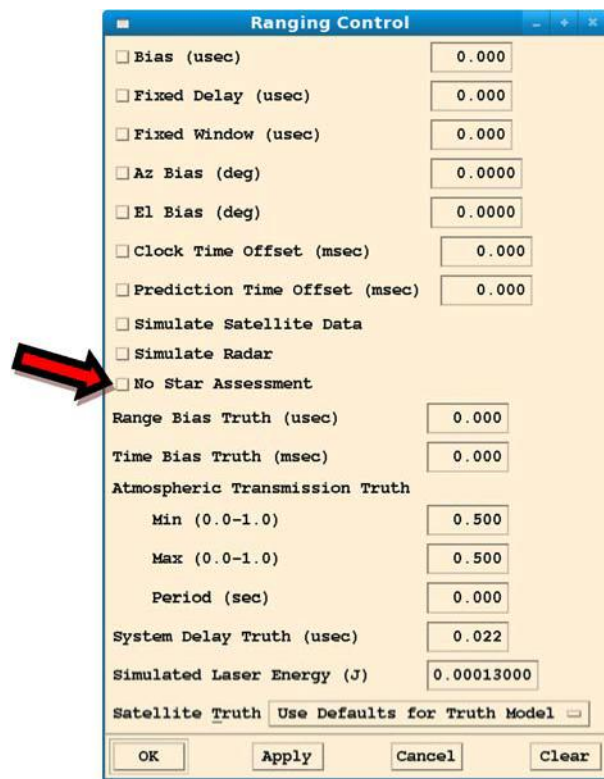

Figure 5-12: Ranging control window for a Star Assessment

6 Performing MINICO and Stability Tests

6.1 Performing a Mini-Collocation (MINICO)

The mini-collocation serves as a way to verify that the system delay remains stable while ranging to multiple stationary targets at various azimuth locations. The system delay refers to the timing delay within the system, and is meant to verify that timing or pointing issues do not adversely affect ranging measurements.

Note: This section assumes that all equipment and software are running and configured as defined in Section 3.

1. **Ensure that the MCP has been powered up for 20-30 minutes to achieve good data stability**
2. **Ensure the area is clear around the calibration pier** – Use the Mount Camera Monitor to ensure that personnel are not near the calibration pier. The operator is required to remain vigilant and verify that personnel do not enter the calibration area during the test.
3. **Run POP** – At the DAM/POP terminal (screen #2), start the operational software by typing:

```
/prod/bin/pop -I <ENTER>
```

Note: Be sure to start the POP software on the “top” part of the minute (between 5 and 25 seconds into the minute) as listed on the GPS Time and Frequency Receiver. POP can potentially crash if it is started too close to the rollover of the minute, which will result in a long reboot (~15 minutes)..

4. **Hit all the Apply buttons on all of the RAT control menus** – This sends the operator override settings to the DAM/POP software.
5. **Verify Weather Measurements** – Ensure that the meteorological data displayed accurately reflects current weather conditions outside the shelter (Figure 6-1). Note that if the values for Sky Clarity are NA, then most likely the Sky Camera software on the Camera computer is not running.

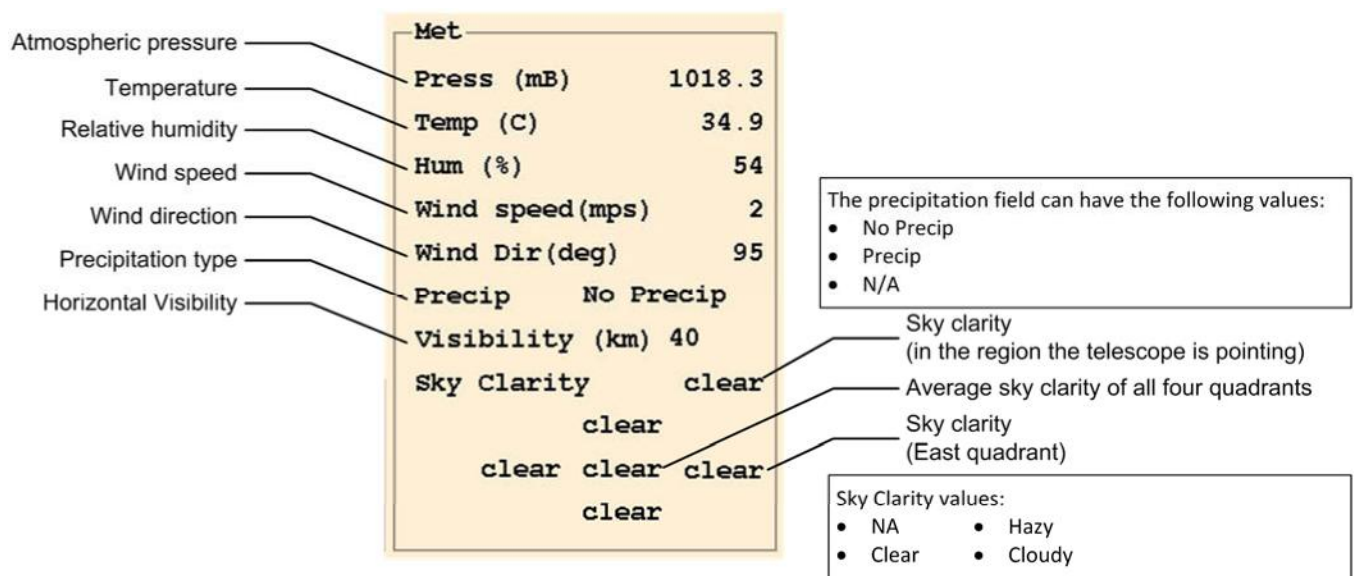

Figure 6-1: Labeled diagram of a portion of the Ratgui main window showing weather information

6. **Open the *Schedule* window and configure for Ground Calibration** – (Figure 6-2)
 - a. On RAT, go to *Control* => *Schedule*.
 - b. Turn *Override Schedule* button on.
 - c. Open the *What to Do* pull down menu and select *Ground Calibration without end*.
 - d. Open the *Cal Targets* pull down menu and select the *C* target as the initial target.

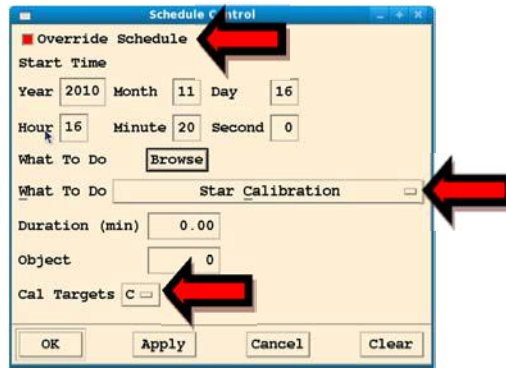

Figure 6-2: Schedule control window

7. **Open the Control => Misc menu** – From the *Data Logging* pull down menu, set *Nothing* (Figure 6-3).

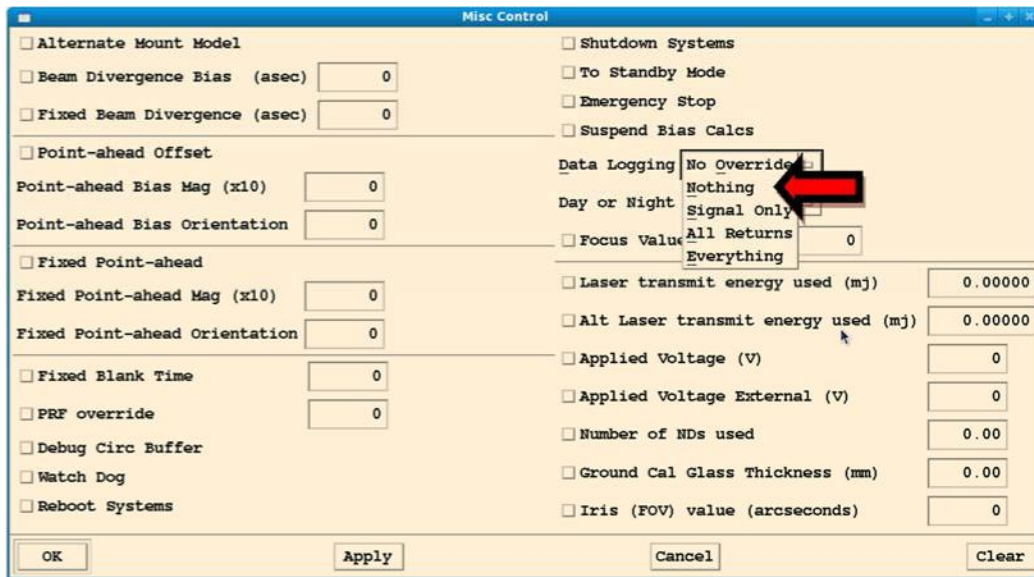

Figure 6-3: Misc Control window

8. **Hit *Apply* on the Schedule and Misc windows** – This will apply the configuration setting: without closing the window.
9. **Press the Enable button on the Enable Control Box** – (Figure 6-4)

Note: The 2 kHz beam block should move out of place and the laser should begin to fire. If not, verify that the **Laser Clear** button is active on the white **Remote Beam Block Control** box at the operator’s console. See Section 8.5 for additional troubleshooting steps if the laser will not fire.



10. **Make sure the laser is firing at the correct rate**
 – This should show up on the main RAT window

Figure 6-4: Enable Control Box (approx. 2 kHz)
 (Figure 6-5).

CPU	Fri Feb 01 2013 (032)	18:18:46	Mode: Calibration	Object:
S2K	2013 (032)	18:18:54	Waiting: Yes	
	Az	El	Range	Dome Az
Telescope	82.4750	-1.9100	0.0	80.9000 Open
Command	82.4750	-1.9100	1.1	82.4750 Open
Scan	0.0000	0.0000	0.0	XE 0.0 F 2000
Model	0.0140	-0.0800		
Bias	0.0000	0.0000		
Error	0.0000	0.0000	0.0	-1.5750 Sun 111.0

Ret %	116.90	#	2338 1
Hit %	108.95	#	2179

Figure 6-5: Ratgui main window showing that the SLR laser is firing at 2 kHz

11. **Open the View => O-C Range Plot** to visually see the returns
12. **Go to View => Quad Detector window** to show the actual signal counts
13. **Verify that the system is receiving between 40 and 200 signal counts** – Adjust the rotary ND filters if necessary to achieve the appropriate number of returns (Figure 6-6).

Quadrant 1		Quadrant 2	
Signal (cts)	0	Signal (cts)	0
Noise (cts)	0	Noise (cts)	0
System Delay (us)	0.0220	System Delay (us)	0.1220
Quadrant 4		Quadrant 3	
Signal (cts)	0	Signal (cts)	94
Noise (cts)	0	Noise (cts)	9
System Delay (us)	0.3220	System Delay (us)	0.0548
Resulting Quad Biases		Combined Calibration	
Az Bias (deg)	NA	System Delay (us)	0.0200
El Bias (deg)	NA		

Adjusting the Rotary ND filters:

The default number of ND's applied by the rotary ND's is 2.0. Look at the signal counts shown in Figure 6-6. If it isn't in between 40 and 200, remove or add ND's using the **Number of ND's Used** entry in the **Misc Control** window to get the number of returns within an appropriate range.

Figure 6-6: Quad Detector window

14. **Record the ND value used for the current target on the log sheet**
15. **Repeat steps 12-14 to collect ND values for each calibration pier (C, A, B)**
 - a. On RAT, go to the Control => Schedule submenu (Figure 6-7).
 - b. Open the Cal Targets pull down menu and select the next target (Figure 6-7).
 - c. Select Apply.

Override Schedule			
Start Time	Year	Month	Day
	2010	11	16
	Hour	Minute	Second
	16	20	0
What To Do	Browse		
What To Do	Ground Calibration Without End		
Duration (min)	0.00		
Object	0		
Cal Targets	C		
OK	Apply	Cancel	Clear

Figure 6-7: Schedule control window

16. Collect data from each calibration pier in this order: (C-A-B-C-A-B-C...)

- a. On RAT, go to the Control => Schedule submenu (Figure 6-8).
- b. Open the Cal Targets pull down menu and select the next target (Figure 6-8).
- d. Adjust the ND value under the Misc Control menu as determined previously (Figure 6-3).
- c. Ensure data is being collected - Go to the Misc Control menu and from the Data Logging pull down menu, set All Returns and select Apply.
- d. Continue collecting returns for ten minutes, or the specified amount of time.
- e. Record the ND value used for the current target on the log sheet.
- f. Repeat step 16 until data has been collected for calibration piers in this order (C-A-B-C-A-B-C).

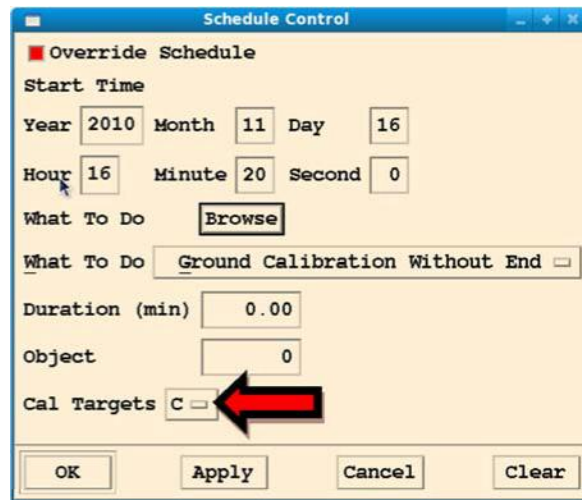

Figure 6-8: Schedule control window

17. Exit POP to stop collecting returns – To do this, go to the DAM/POP console and type “x <ENTER>.”

6.2 Performing a Stability Test

This test verifies stability of the system delay over a designated period of time to a stationary ground target.

Note: This section assumes that all equipment and software are running and configured as defined in Section 3.

1. **Ensure that the MCP has been powered up for 20-30 minutes to achieve good data stability**
2. **Ensure the area is clear around the calibration pier** – Use the Mount Camera Monitor to ensure that personnel are not near the calibration pier. The operator is required to remain vigilant and verify that personnel do not enter the calibration area during the test.
3. **Run POP** – At the DAM/POP terminal (screen #2), start the operational software by typing:

```
/prod/bin/pop -I <ENTER>
```

Note: Be sure to start the POP software on the “top” part of the minute (between 5 and 25 seconds into the minute) as listed on the GPS Time and Frequency Receiver. POP can potentially crash if it is started too close to the rollover of the minute, which will result in a long reboot (~15 minutes).

4. **Hit all the Apply buttons on all of the RAT control menus** – This sends the operator override settings to the DAM/POP software.
5. **Verify Weather Measurements** – Ensure that the meteorological data displayed accurately reflects current weather conditions outside the shelter (Figure 6-9). Note that if the values for Sky Clarity are NA, then most likely the Sky Camera software on the Camera computer is not running.

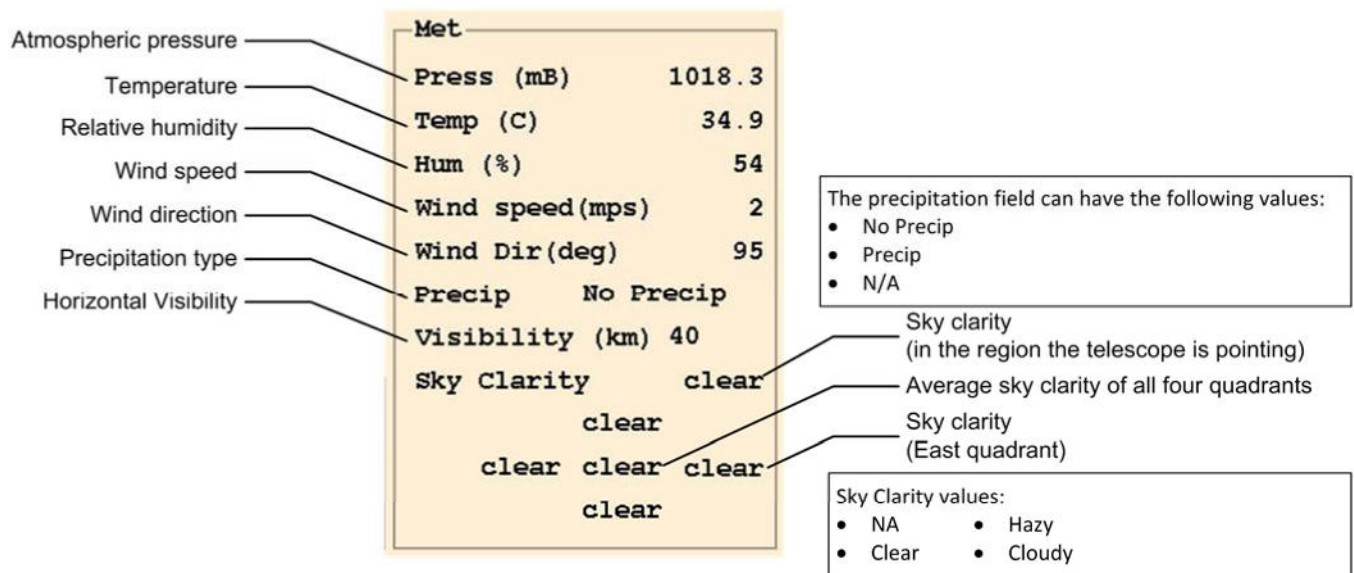

Figure 6-9: Labeled diagram of a portion of the Ratgui main window showing weather information

6. Open the **Schedule** window and configure for Ground Calibration (Figure 6-10)
 - a. Go to the Control => Schedule submenu.
 - b. Turn Override Schedule button on.
 - c. Open the What to Do pull down menu and select Ground Calibration Without End.
 - d. Open the Cal Targets pull down menu and select the C target.

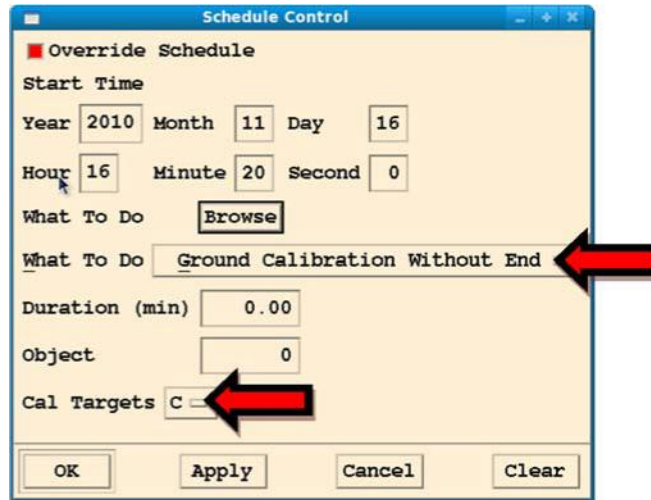

Figure 6-10: Schedule control window

7. Open the Control => Misc menu – From the Data Logging pull down menu, set Nothing (Figure 6-11).

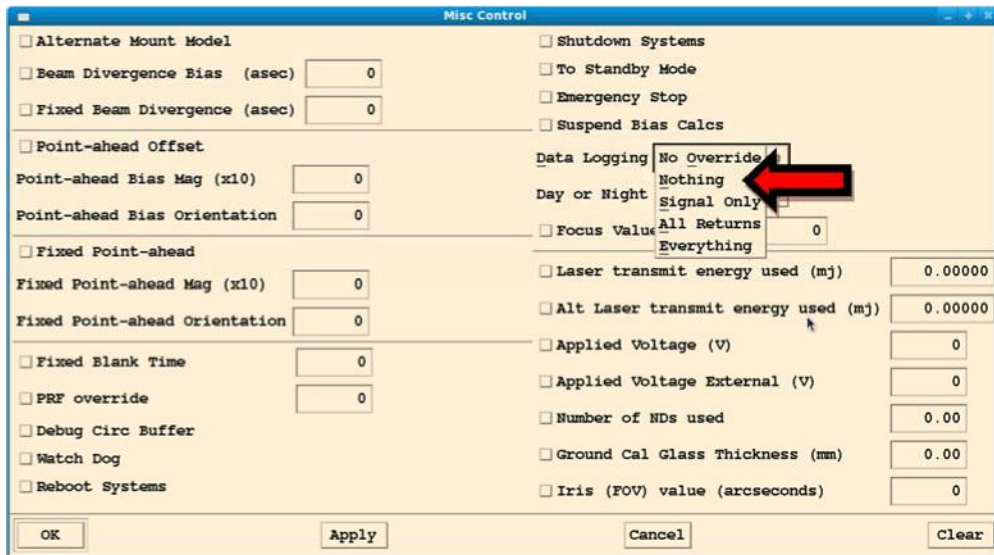

Figure 6-11: Misc Control window

8. Hit **Apply** on the Schedule and Misc Menus – This will apply the configuration settings without closing the window.

9. Press the **Enable** button on the Remote Enable Box (Figure 6-12)

Note: The 2 kHz beam block should move out of place and the laser should begin to fire. If not, verify that the **Laser Clear** button is active on the white **Remote Beam Block Control** box at the operator’s console. See Section 8.5 for additional troubleshooting steps if the laser will not fire.



Figure 6-12: Remote Enable Box

10. **Make sure the laser is firing at the correct rate** (approx. 2 kHz) – This should show up on the main RAT menu (Figure 6-13).

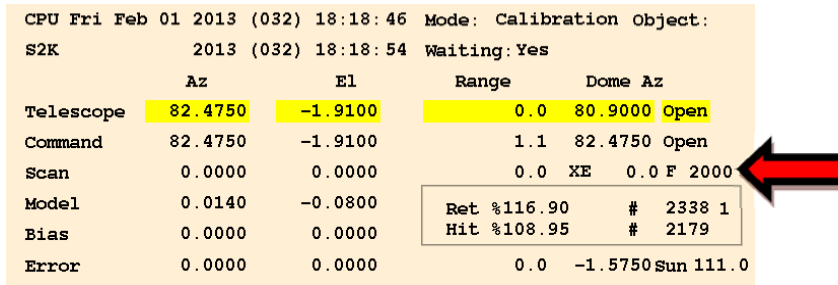

Figure 6-13: Ratgui main window showing that the SLR laser is firing at 2 kHz

11. Open the View => O-C Range Plot to visually see the returns
12. Go to View => Quad Detector window to show the actual signal counts (Figure 6-14)
13. Verify that the system is receiving between 40 and 200 signal counts (Figure 6-14) – If necessary, adjust the rotary ND filters to achieve the appropriate number of returns (See note below).

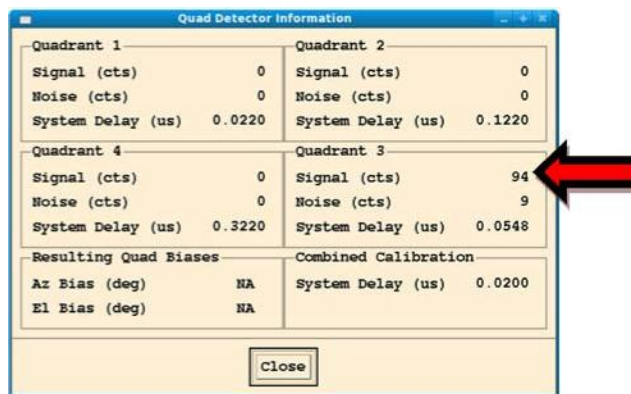

Figure 6-14: Quad Detector window

Adjusting the Rotary ND filters: The default number of ND's applied by the rotary ND's is 2.0. Look at the signal counts shown in Figure 6-14. If it isn't in between 40 and 200, remove or add ND's using the **Number of ND's Used** entry in the **Misc Control** window to get the number of returns within an appropriate range (Figure 6-11).

14. **Begin to Collect Data** – Go to the Misc menu and from the Data Logging pull down menu, set All Returns and select Apply.
15. **Continue collecting returns for one hour** (or as specified by the development team)
16. **Exit POP to stop collecting returns** – To do this, go to the DAM/POP console and type "x <ENTER>."

7 Shutting down the System



Warning: The following equipment should never be turned off!*

GPS Time and Frequency Receiver (XL-DC)	Range Gate Generator (RGG)
Computer Clock Sync Interface (CCSI)	Constant Fraction Discriminator
Cesium Frequency Standard	The NIM Crate
Event Timer (ET)	Power Distribution Box

*Except in the case of an emergency that presents possible danger to personnel or equipment.

Turn off the devices listed in the instructions below. Leave both large monitors at the Operators Console ON.

1. **If running, stop the POP software** – Type “x <ENTER>” at the POP keyboard.
2. **Log out of DAM & POP** – Log out of DAM/POP by typing “exit <ENTER>” at the POP screen.
3. **Shut down the laser controller and exit the laser control software**
 - a. Click on the SHUTDOWN button on the laser control software.
 - b. Once the SHUTDOWN button turns bright green, close the PI Laser Control window.
4. **Exit the Star Camera Software** – Exit the Star Camera program on the Camera computer if running.

Note: Leave the Camera computer **ON**.



Warning: The lights must remain OFF in the back area until the High Voltage Power supply for the PMT is shut off! Otherwise, permanent damage to the PMT could result.

5. **Slide the protective card in front of the light tight box to the BLOCKED position** – This is in place as a manual backup to the shutter.
6. **Turn off the Bertran High Voltage Power supply**
 - a. Ramp down in 500 V steps to 450 V.
 - b. Turn OFF the device.
7. **Turn OFF the SLR Power Strip**
8. **Physically shut off the Laser**
 - a. Turn Laser Enable key to off position. Remove key and put in designated location.
 - b. Flip On/Off red rocker switch labeled Power on the laser driver to the OFF position.
9. **Close the dome**
 - a. Set the shutter to CLOSE.
 - b. Turn key to ENABLE and wait for dome to close.
 - c. When dome has closed completely, turn the key back to the upright position.
10. **Turn off the LHRS radar** – Turn off the local controller at the top of Rack #1 (See Figure 7-1).

11. **Power off dome driver, dome controller, and shutter controller** (See Figure 7-1)
12. **Turn off the ICC** – Switch the screen selector button on the rack mount keyboard/monitor to #1 for ICC (See Figure 7-1). Stop the ICC software by typing “x” and then turn the ICC power switch to OFF.
13. **Power down the mount servo controller** (See Figure 7-1)
 - a. Servo (mount) controller: Control power [*middle switch*]
 - b. Servo (mount) controller: Main power [*left switch*]
14. **Shutdown RAT** – Exit RAT GUI (Go to **File** → **EXIT**) and shutdown the computer by selecting Shutdown from the System menu at the top of the screen.
15. **Complete the log sheet** – Fill out any information that is pertinent to the tracking shift, noting any anomalies that had not previously been reported.
16. **Turn OFF the monitor for the telescope camera**

Only perform step 17 if this is the last shift of the week. Otherwise, continue to step 18.

17. **Call the NCRCC** – Call the NCRCC at the end of operations for that week. Say something similar to:
“This is Joe Smith at the Goddard Space Flight Center. I am calling to inform you that we are ending this operational session. Our next shift we will be operating from [date/time] to [date/time].”

18. **Ensure that the laser curtain is closed**
19. **Lock the facility door on your way out**
20. **Verify that the stairway chain and warning sign are in place on the ladder to prevent unauthorized access to the roof deck**
21. **Verify from the outside that the dome has closed**

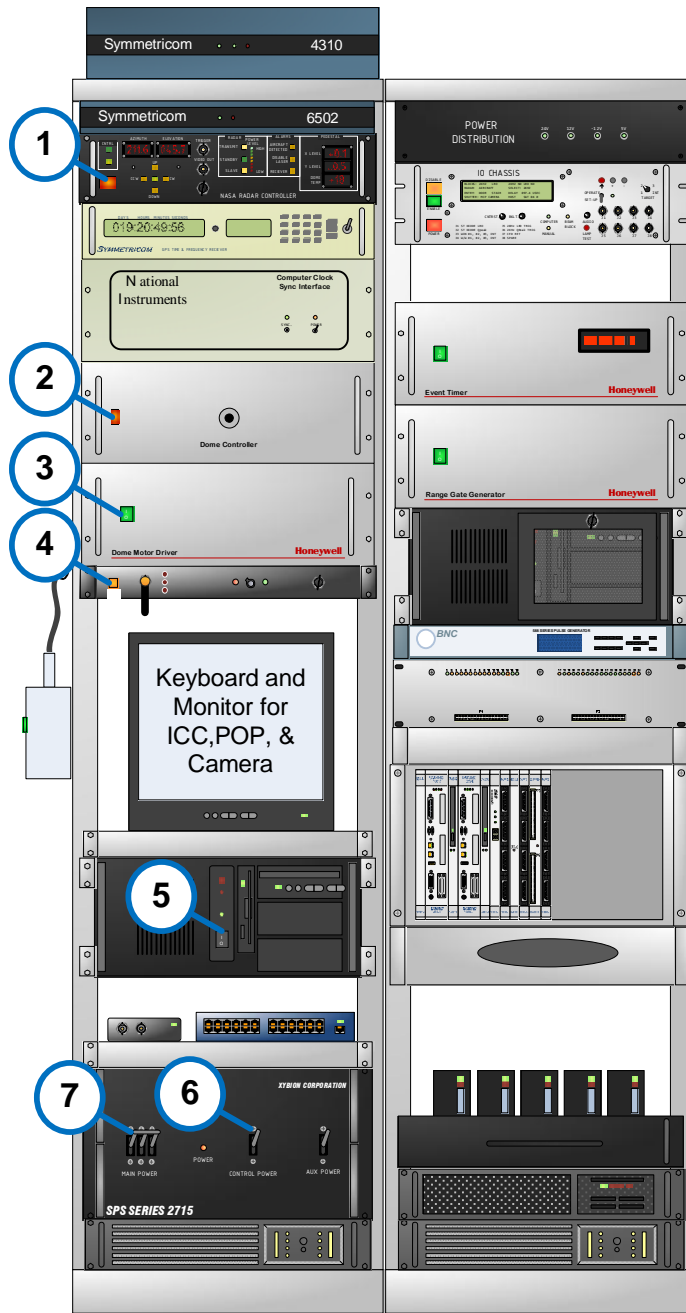

Rack 1

Rack 2

Figure 7-1: Equipment Power OFF Sequence

8 Most Common Errors and Their Resolutions

8.1 Getting the “MET” error message on POP for longer than 10 minutes

This error typically shows up when the met_archive software isn't running on DAM.

To start the software

1. Switch to the DAM session* on the DAM/POP terminal
2. Log in as operator
3. Start met_archive by typing: `start_met <ENTER>` then `exit <ENTER>`

This will restart the met_archive and log you out of the DAM computer.

**Press ALT-F4 to go to screen 3. You should see a “3” at the bottom left of the screen indicating that you are on DAM.*

8.2 No image on the monitor for the Telescope Camera

The telescope camera has four locations that should be checked to verify that a video signal is being transmitted and that power is properly supplied to the telescope camera system. In the shelter, verify that the Power Distribution chassis used by the telescope camera is ON, as indicated by the LED's on the front panel (Figure 8-1). In the dome, verify that the wireless receiver is plugged in and functional as evident by the LED on the top of the device (Figure 8-2). On the top of the telescope mount, verify that the transmitter is plugged in (Figure 8-3), and that the wires to the telescope camera have not been compromised (Figure 8-4). Both the transmitter and the camera have LED lights on them indicating whether they have power. Also, it may be necessary to cycle power on the transmitter if no video is being transmitted.



Figure 8-1: Power Distribution Box in Rack #2



Figure 8-2: Wireless receiver in the dome



Figure 8-3: Wireless transmitter for the Mount Camera



Figure 8-4: Camera on Telescope (LED's on back)

8.3 Mount won't drive / Mount dumps (Elevation > 90°)

This usually manifests as a problem with the mount (servo) controller. To fix this, perform the following:

1. Stop the ICC software.
 - a. Switch to the ICC console
 - b. Type: `x <ENTER>`
 - c. Turn the ICC OFF
2. Turn off the servo controller (Turn **OFF** the middle switch first, then the left switch).
3. Count to 10 and turn servo controller back **ON** (Left switch first, then the middle switch).
4. Reboot the ICC .

8.4 The laser is firing, but the RAT display shows laser fires are zero (f=0)

Most likely there is a problem with the start diode, the start diode cable, or possibly with the software. For a software issue, perform the following:

1. Go to the DAM/POP console (screen #2) and stop the POP and DAM software.
Type: `x <ENTER>` then `exit <ENTER>`
2. Wait until you see the username prompt at the DAM/POP keyboard. Then log back in to both machines and try again.

8.5 The laser won't fire

1. **Verify that there are no safety conditions preventing the laser from firing** – Look on the Ratgui main window or on the IO Chassis display to see if there are any safety conditions that would prevent the laser from firing, such as aircraft detect, stair detect, etc.
2. **Verify that the Laser Clear button is active** – Press the Laser Clear button on the white Beam Block Control Box at the operator's console (Figure 8-5).



Figure 8-5: Beam Block Control Box



Figure 8-6: Radar mask and Sun Avoidance alerts



Figure 8-7 - Enable Control Box

3. **Verify that the laser is enabled** – Press the Enable button on the Enable Control Box (Figure 8-7).
4. **Verify the Remote IO Control box is in the COMPUTER mode** – Press the green toggle button to ensure that the box is in the COMPUTER mode.

5. **Verify that the telescope is not pointed toward the radar mask for VLBI or is in Sun avoidance** – Refer to the error message area on RAT for any active alerts (Figure 8-6).
6. **Verify that the ICC is not preventing the laser from firing** – Check the ICC screen on the rack console to verify that the ICC is directing the laser to fire as shown on Figure 8-8. The ON indicates that the ICC is sending commands to fire the laser, OFF indicates that the ICC is actively preventing laser fire due to one of the below conditions:
 - *The dome isn't close enough to the correct location (within 5°)*
 - *The mount isn't close enough to the commanded location (within 0.005°)*
 - *The mount is below 20° elevation (unless you are in ground calibration mode)*

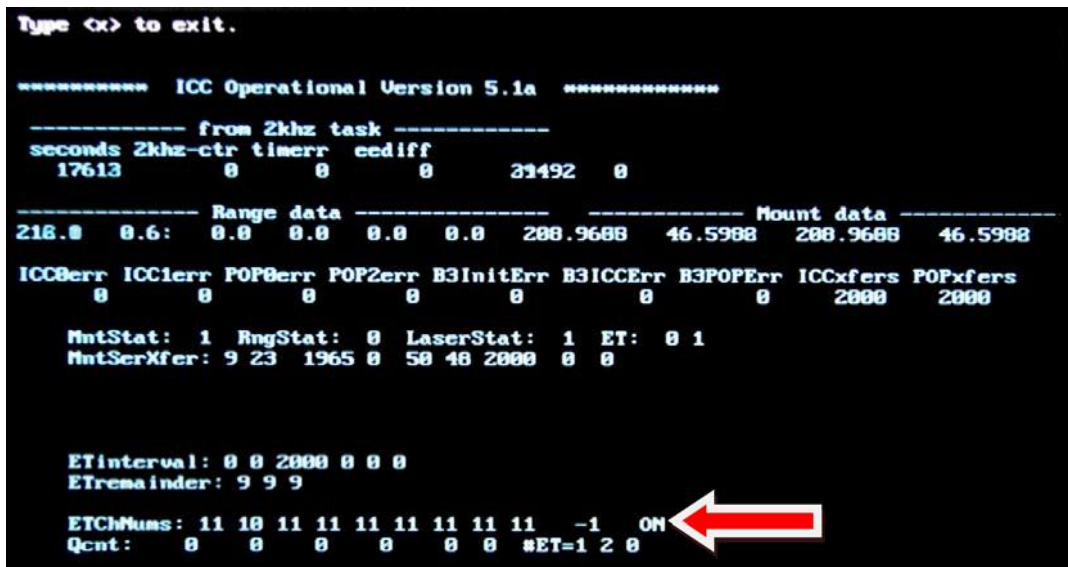

Figure 8-8: Screenshot of the ICC showing that it is sending commands to fire the laser.

- a. **Verify that the azimuth of the dome and telescope are within 5°** – Using the RAT display, compare the commanded azimuth of the mount and the actual azimuth of the dome (Figure 8-9). The difference between the two should be within 5° for the laser to fire. If the difference is greater than 5°, reboot the Dome Controller and the Dome Motor Controller to reset the dome control system.

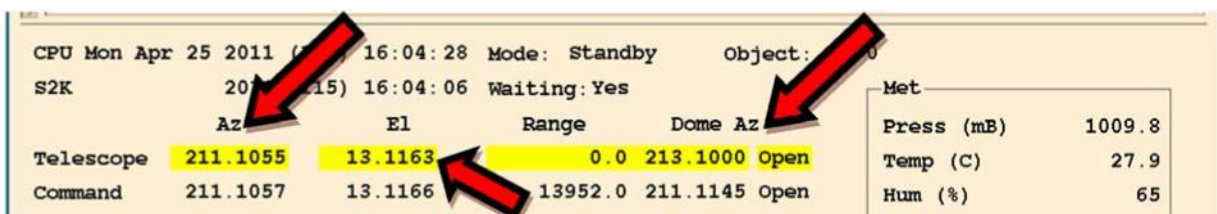

Figure 8-9: Section of Ratgui menu showing the mount and dome azimuth values

- b. **Verify that the mount is not below 20° elevation** – If it is the beginning of a satellite pass, the system may start tracking before the laser is enabled to fire. Remember that the system will not fire the laser when the mount is below 20° in elevation, unless it is configured to perform a ground calibration (Figure 8-9).

- c. **Verify that the mount is within 0.005° to the commanded location** – Check on the status of the mount, comparing the azimuth and elevation differences on the RAT display. The mount must be within 0.005 degrees for the laser to fire (Figure 8-10).

Note: There is an exception for high elevation passes where the tolerance is much larger.

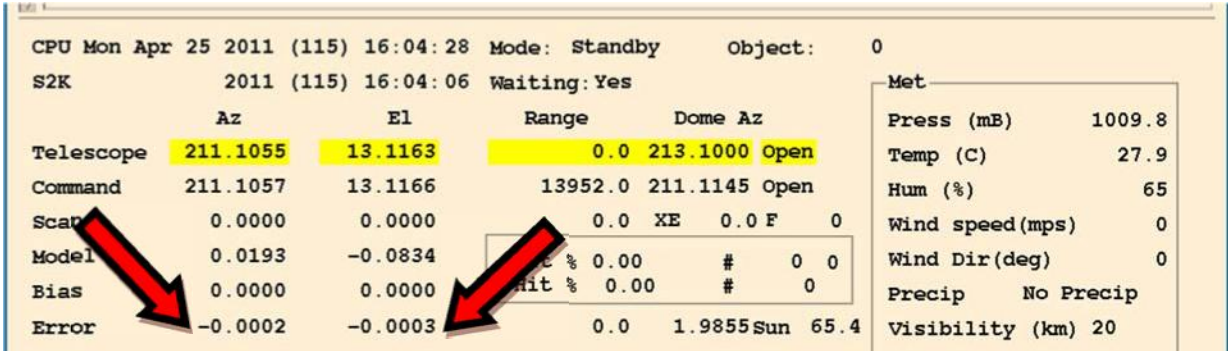

Figure 8-10: Position error between the commanded and actual pointing of the telescope

- 7. **Verify that the status of DAM is green** (Figure 8-11)

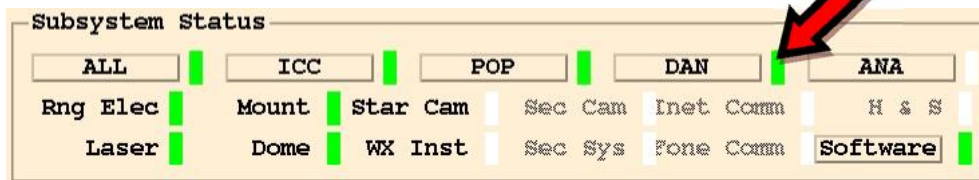

Figure 8-11: DAM Subsystem Status

- a. If the status is any color other than green, click on the status button (Figure 8-11).
- b. Search the pop-up window for error messages regarding the motorized devices (Figure 8-12).

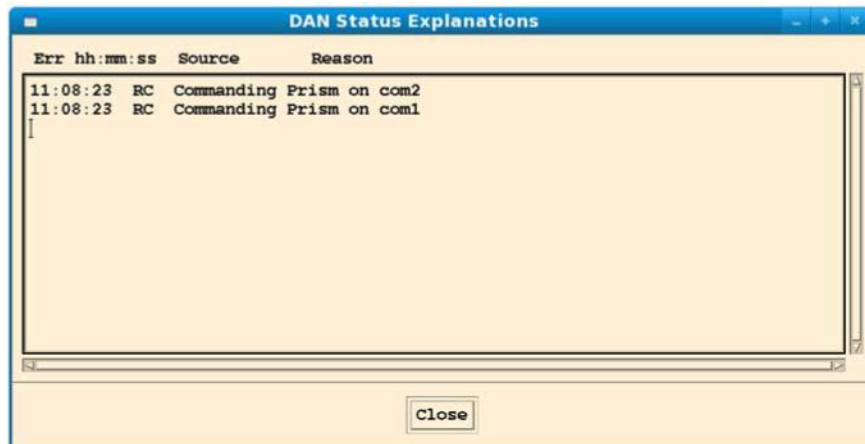

Figure 8-12: DAM Status Explanation Window

8. **Verify that the Motor Controllers are not in an error state** – Check the status LED’s on the Motor Controllers (Figure 8-13).

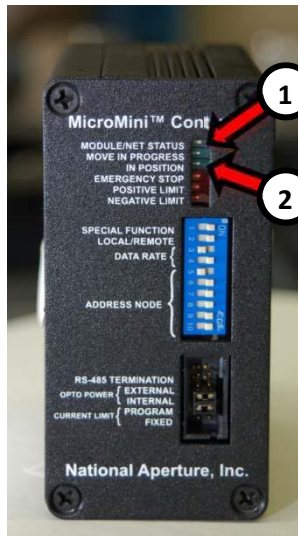

Figure 8-13: MVP Motor Controller

1. MODULE/NET STATUS

- Flashing green = Not Initialized/Allocated
- Steady green = Initialized/Allocated
- Flashing Red = Recoverable Communications Error
- Steady Red = Unrecoverable Communications Error

If this LED is red (flashing or steady), stop operations and call a NGSLR system engineer to reset the controller.

2. IN POSITION

If this LED is green, the motorized stage is in the proper position and is operating appropriately.

9. **Check the laser configuration settings on the front panel of the laser controller**
10. If you have checked all of these steps and the laser still refuses to fire, check with the NGSLR Lead, NASA SLR Manager, or the Engineering Lead for the appropriate course of action. Inform them of each step attempted in the troubleshooting process, along with the result.

8.6 System is not getting returns

8.6.1 No returns during ground calibrations

1. **Verify that the laser is firing** (If not, see Section 8.5)
2. **Verify that that noise shows up on the O-C plot on RAT, the PMT is ON and that the beam block has been manually removed**
3. **Verify that the dome is open**
 - a. During the day – Can you see the target in the telescope camera monitor?
 - b. During the night – Can you see the laser reflection off of the target in the telescope camera monitor?
4. **Verify that the target is not dirty, obscured, covered in moisture (dew/frost), rotated out of alignment, etc**
5. **Verify that the Risley prisms are zeroed during the ground calibration**
6. **Try to add pointing bias to the telescope using the *Handpaddle or Ranging Control* in Ratgui**
7. **Review the startup checklist** – Ensure that all equipment has been appropriately powered on and is running according to procedure.
8. **If you have verified all of these steps, and the problem is still not solved, check with the NGSLR Manager, NASA SLR Manager, or the Engineering Lead for the appropriate course of action** – Inform them of each step attempted in the troubleshooting process along with the result.

8.6.2 Low return rate during a ground calibration

1. **Remove ND’s using the Rotary ND wheels** (Figure 8-14)

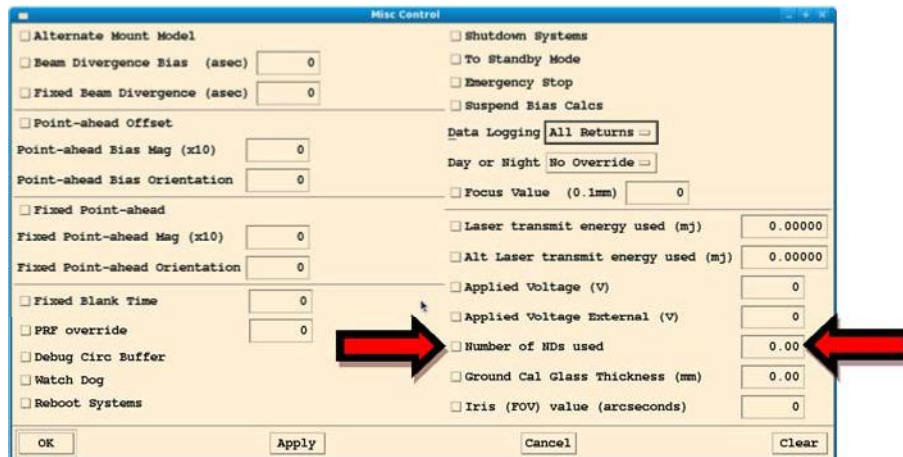

Figure 8-14: The Misc Control window showing All Returns selected

Adjusting the Rotary ND filters: The default number of ND’s applied by the rotary ND’s is 2.0. Look at the counts shown in Figure 6-11. If it isn’t in between 40 and 200, remove or add ND’s using the **Number of ND’s Used** entry in the **Misc Control** window to get the number of returns within an appropriate range.

8.6.3 No returns during satellite tracking

1. **Ensure that the laser is firing** (If not, see Section 8.5)
2. **Verify the PMT beam block has been manually removed**
3. **Check sky conditions to verify that clouds are not blocking the signal**
4. **Verify that the PMT is ON and that noise shows up on the O-C plot on RAT**
5. **Verify that the dome is open**
 - a. During the day – Can you see the target in the telescope camera monitor?
 - b. During the night – Can you see the laser reflection off of the target in the telescope camera monitor?
6. **Add pointing bias to the telescope**
7. **Verify that the meteorological data is being logged properly** – Values for the pressure, temperature, wind speed, etc. should all be within normal ranges.

8.7 The software appears to have crashed/is non-responsive

If the POP software stops unexpectedly, especially when it declares a “segmentation fault,” then chances are that you will need to reboot the system. If the system responds to keyboard input, perform a soft reboot. See the section [How to do a soft reboot on POP](#) for more information. Please note that you will also need to reboot the RAT laptop computer *after* you have rebooted POP.

If the DAM/POP terminal is unresponsive to keyboard input, you will need to perform a hard reboot. *Note: Performing a hard reboot may affect both POP and DAM.* See the section [How to do a hard reboot on POP](#) and [How to do a hard reboot on DAM](#) for more details.

If both POP and DAM are rebooted you should re-mount the disk drives on both of these machines. See [Remounting the disk drives on POP and DAM](#).

8.7.1 How to do a soft reboot on POP

POP must be rebooted using the rack mounted keyboard.

1. **Switch to POP using the labeled button on the KVM and type:** `reset <ENTER>`
2. **When asked for the password, use the operator password** – The computer should automatically reboot and display the username prompt on the screen.
3. **Follow normal login procedures from this point**

Note: Whenever POP is rebooted, you must also reboot RAT. See [How to do a soft reboot on RAT](#).

8.7.2 How to do a hard reboot on POP



Only perform a hard reboot of POP if all else has failed, you have been trained on the procedure, and you have been approved by the NASA SLR Lead! Note that whenever the POP computer is rebooted, you must also perform a hard reboot on RAT. This process takes approximately 15 minutes to complete and should only be used as a last resort.

1. Use the “reboot tool” to press the recessed button labeled “RST” on the front of the POP computer (Figure 8-15). Make sure you select the correct computer and don’t accidentally reset DAM. The POP computer will go through several file system checks, which may prove to be a lengthy process.
2. Once the login screen comes up, login and follow normal operating procedures from this point.

8.7.3 How to do a soft reboot on DAM

If the DAM status color goes orange or white (see Appendix C) and remains that color for more than 5 minutes, then DAM needs to be rebooted. DAM must be rebooted using the DAM/POP terminal.

You should see a “3” at the bottom left of the screen indicating that you are on DAM. If not, press ALT-F4 to go to the DAM computer.

1. Type: `reset <ENTER>`
2. When asked for the password, use the operator password. The computer should automatically reboot and display the username prompt on the screen.
3. Log in and start met_archive by typing in: `start_met <ENTER>`, then `exit <ENTER>`
4. Follow normal procedures from this point.

8.7.4 How to do a hard reboot on DAM



Only perform a hard reboot of the DAM computer if all else has failed, you have been trained on the procedure, and you have been approved by the NASA SLR Lead! This process takes approximately 15 minutes to complete and should only be used as a last resort.

If the keyboard is unresponsive on the DAM/POP terminal, or the soft reboot hangs, you will need to do a hard reboot of the DAM computer. Use the “reboot tool” to press the recessed button labeled “RST” (Figure 8-15) on the front of the DAM computer. Make sure you select the correct computer and don’t accidentally reset POP.

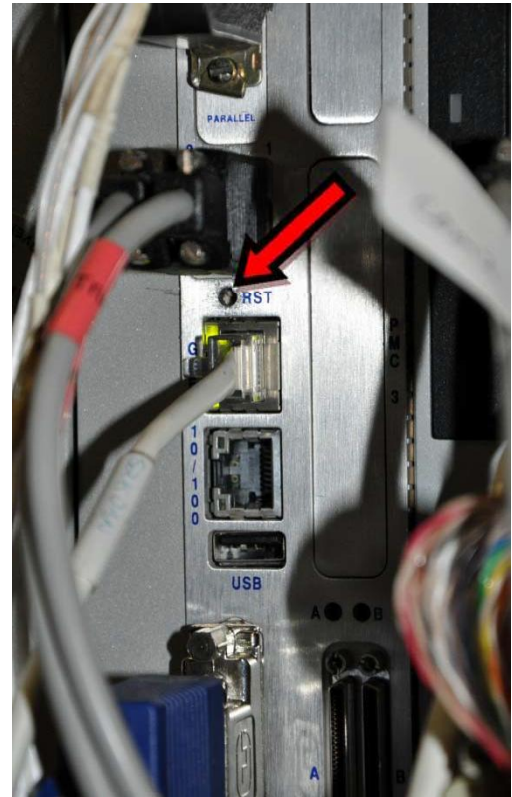

Figure 8-15: The reboot button is located at a similar location on the POP and DAM computers

The DAM computer will go through several file system checks, which may prove to be a lengthy process. Log into DAM using the DAM/POP terminal. You should see a “3” at the bottom left of the screen indicating that you are on DAM. If not, press ALT-F3 to go to the DAM computer.

1. Log in and start met_archive by typing in: `start_met <ENTER>`, then `exit <ENTER>`
2. Follow normal procedures from this point.

8.7.5 Remounting the disk drives on POP and DAM

If both POP and DAM are rebooted you should re-mount the disk drives on both of these machines.

1. On POP, after logging in as operator type: `/mount_DANdirs<ENTER>`

The response will be either the mounting of the disks or error messages saying the “...resource is busy.” Regardless of the message, the result will ensure the mounting of the disks.

2. On the DAM/POP console switch to screen 3 (Alt-F4)
3. Log in as operator
4. Type: `/mount_popdirs <ENTER>`

8.7.6 How to do a soft reboot on RAT

1. On the RAT laptop, exit out of the RAT software by selecting **FILE → EXIT**.
2. Under the SYSTEM menu at the top left of the laptop screen, select **SHUTDOWN**.
3. When the pop-up menu gives you a selection of what to do, select **RESTART**.
4. Follow the startup instructions included in Section 2 of this document.

8.7.7 How to do a hard reboot on RAT

1. Press and hold the power button on the RAT laptop until the system reboots
2. Follow the normal login and startup procedures for RAT

Note: These the drives should be mounted on both POP and DAM before starting prior to starting MET_ARCHIVE.

8.7.8 How to do a soft reboot on the Camera Computer

To reboot the computer, close all open programs and windows, click the START button in the lower left corner of the screen, and select Shut Down (Figure 8-16).



Figure 8-16: Start and Shut Down buttons

A window will pop up with a pull down menu. Select Restart and then click the OK button (Figure 8-17). At this point the computer should shutdown and restart. Log in again to once again begin operations.



Figure 8-17: Select Restart and click OK to reboot

8.7.9 Starting NFS after turning on/rebooting the Camera Computer

If the Camera computer is rebooted or the NFS software crashes, you will need to manually start the NFS software. To set up the NFS server:

1. Double click on NFS server icon (Shown at right)
2. Select the **Show Icon on System Taskbar** checkbox (Figure 8-18)
3. Click on the **Hide** button (Figure 8-18)

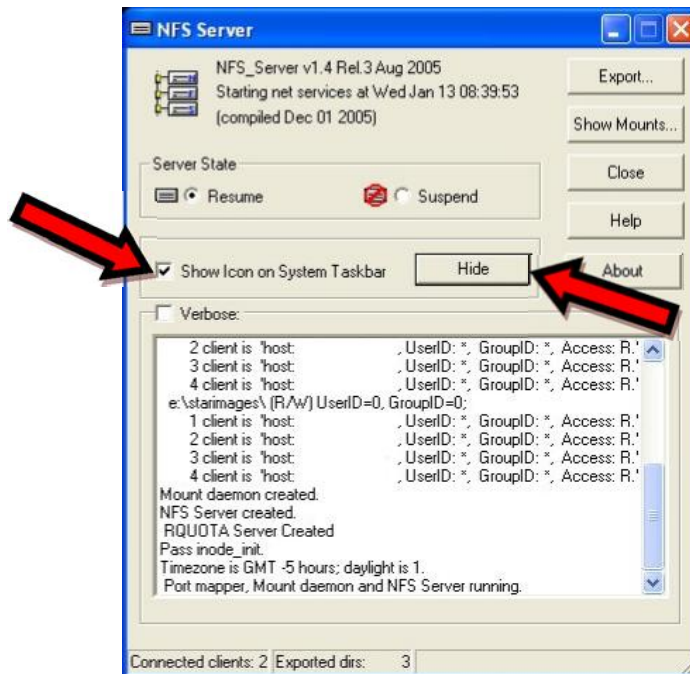

Figure 8-18: NFS Server Window

You will have to manually ensure that the connection with POP has been established by double clicking on “My Computer” and then double click on “Share 1” which has drive letter “M:\”. Once this comes up you have successfully established communication and you can close the folder (use the “X” in the upper right hand corner of the folders).

8.8 Event Timer Resets

Occasional resets of the Event Timer should not pose a problem, though if they occur with increasing frequency, they may allude to high noise rates being received by the system. If this is the case, verify that the iris and the band pass filter are set correctly for the conditions.

If the receiver is flooded with returns, which means ~4000 events/sec or greater, then it won't be able to keep up, and will end up being reset.

8.8.1 Event Timer Continually Resets

If the 1 PPS is disconnected from the Event Timer, or it is receiving a bad signal, it can cause the Event Timer to continually reset. Verify that the 1 PPS cable is connected, and that the Event Timer is getting a good 1 PPS signal.

This is critical because the ICC checks synchronization by verifying that the delay between the 1 PPS signal and the 2 kHz on-time is 9.8 μ s in length. If the ICC sees several delays that do not match this, it determines that it is out of sync, and a reset of the Event Timer is necessary. Hence, if there is no 1 PPS, the signal is erratic, or it is from a source other than the True Time XL-DC, the ICC will continually assume that it is out of synch with Event Timer.

8.9 Dome won't open or close

This could be caused by a failure of the electronics, solar panel, or battery. In these cases, an external power supply can be used to open and close the dome.

1. Connect AC power to the dome auxiliary power box. Note that the receptacle is a GFI and the AC input on the power box contains an ON/OFF switch.
2. Next, connect the two position circular connector to the power box. The other end (yellow plug) connects to the covered "outlet" next to the toggle switch.
3. In normal operation, the toggle switch should be on "BATTERY POWER". Flip the switch up to "EXTERNAL POWER".
4. Use the toggle switch on the power box to select "OPEN" or "CLOSED".

See the Dome Shutter Control Manual for more details and pictures.

Appendix

Appendix A: Acronyms

Acronym	Definition
AC	Alternating Current
ANSI	American National Standards Institute
FAA	Federal Aviation Administration
GFI	Ground Fault Interrupter
GGAO	Goddard Geophysical and Astronomical Observatory
GPS	Global Positioning System
ILRS	International Laser Ranging Service
IOC	IO Chassis
LAGEOS	Laser Geodynamics Satellite
LHRS	Laser Hazard Reduction System
LOA	Laser Operations Area
LRO	Lunar Reconnaissance Orbiter
LSO	Laser Safety Office
MCP	Micro-Channel Plate
MINICO	Mini-Collocation
NCRCC	National Capital Region Coordination Center
ND	Neutral Density
NFS	Network File System
NGSLR	Next Generation Satellite Laser Ranging
NIM	Nuclear Instrumentation Module/Method
OD	Optical Density
PMT	Photo Multiplier Tube
PPS	Pulse Per Second
RF	Radio Frequency
RMS	Root Mean Square
SLR	Satellite Laser Ranging
VLBI	Very Long Baseline Interferometry

Appendix B: NGSLR Laser Ranging Log Sheet

Sample of the NGSLR Operations Log Sheet

NGSLR Operations Log Sheet

DOY

MONTH / DAY / YEAR

DATE OF LAST LHRS VERIFICATION

Operations Personnel Information

Operator / Laser User		
POP Version		FAA / NCRCC Contact
Shift Start	DOY / UTC	
Shift End	DOY / UTC	

Star Calibration *(if performed)*

	Start Time (UTC)	RMS Value (arcsec)	Comments
First Star Calibration			
Second Star Calibration			
Post Star Cal Quality Check		North / East / South / West ▶	

Table of Passes

1	Target	Start Time	FOV	Filter / ND	Sky			Bias		Hit	Voltage	Comments
	Satellite / Calibration Target	(approx.)	arcsec	Daylight / # of	Clear	Hazy	Partly Cloudy	Az.	EL	(Y/N)	Start Diode	
2												
3												
4												
5												
6												
7												
8												
9												
10												
11												
12												

Comments *(i.e. problems encountered, alignment changes, configuration settings, etc)*

Rev. 0.4

Check here if additional sheets were used

Page | 1

Appendix C: Alert statuses

See the NGSLR Software manual for more details on status message alerts.

Subsystem Status Color Table	
Color	Description
white	Computer or subsystem not turned on
green	OK
Below colors indicate that the system is not OK, listed in order of severity (mild to most severe)	
yellow	Alert
orange	Warning
red	Severe
black	Most Severe

Appendix D: Measuring the Laser Power

SLR laser pulse measurements must be made once per shift, typically at the beginning of the shift.

1. Turn the power meter on using the toggle switch on the back of the device (Figure D-1)



Figure D-1: Power Energy Meter

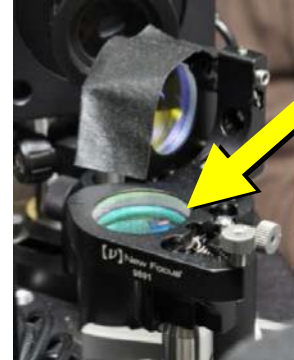

Figure D-2: Manual Insertion Mirror (horizontal)

2. Close the laser curtain and put on protective eyewear
3. Flip the Manual Insertion Mirror for the power meter into the vertical position (Figure D-2)



Warning: Close the laser curtain and put on protective eyewear before turning on the laser. Inform all present that the laser is being turned on. Minimum eyewear optical density for the SLR laser is **>4.7 ND @ 532nm**. Failure to follow these guidelines can result in severe eye damage to anyone exposed to the beam.



Warning: Keep hands and arms away from the transmitted beam at all times. At no point in this procedure should the operator adjust any optical device while the laser is ON. Remove any reflective/shiny jewelry before entering the Laser Operations Area.

4. Turn on the SLR laser and set emission levels to tracking power (Figure D-3)
5. Go to the front panel of the SLR laser controller and change triggering to **INTERNAL**

- a. Press the **Menu** button on the laser driver.
- b. Under **Pulse Settings**, set **Trigger** to **INT**.



Figure D-3: PI laser Interface at Tracking Power

6. **Take a laser energy measurement** – The laser will be operating at tracking energy if a reading of ~ 1 mJ is observed (Figure D-4). If the power meter shows a reading in watts, select the far left button to toggle to the energy mode.



Figure D-4: Power Meter taking a typical reading.

7. **Go to the front panel of the SLR laser controller and change triggering back to *EXTERNAL***
 - a. Press the **Menu** button on the laser driver.
 - b. Under **Pulse Settings**, set **Trigger** to **EXT** for tracking operations.
8. **Shut down the laser** – Shut down the SLR laser using the software interface, then lock the controller using the key switch and power down.
9. **Return the manual insertion mirror to the horizontal position**
10. **Record the energy measurement on the NGSLR Tracking log sheet**

Appendix E: Measuring the Start Diode Voltage

During a tracking shift, it is necessary to monitor the start diode voltage. Follow the below steps to complete the measurement.



Warning: Close the laser curtain and put on protective eyewear before turning on the laser. Inform all present that the laser is being turned on. Minimum eyewear optical density for the SLR laser is **>4.7 ND @ 532nm**. Failure to follow these guidelines can result in severe eye damage to anyone exposed to the beam.



Warning: Keep hands and arms away from the transmitted beam at all times. At no point in this procedure should the operator adjust any optical device while the laser is ON. Remove any reflective/shiny jewelry before entering the Laser Operations Area.

1. **Turn ON the oscilloscope**
2. **Verify start diode connectivity** – Check the connection between the directional coupler and the oscilloscope (Figure E-1).
3. **With the laser firing, take a measurement** – Adjust the trigger level on the oscilloscope as needed to obtain an accurate reading. The voltage should be ~240 mV (Figure E-2).
4. **Record the measurement on the log sheet**
5. **Turn OFF the Oscilloscope**

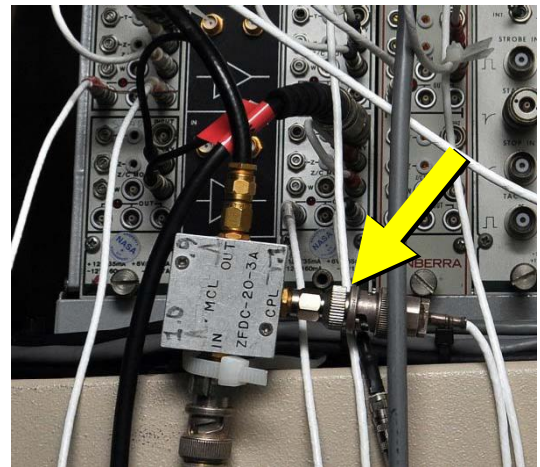

Figure E-1: Arrow on the directional coupler shows the port used to send the signal to the oscilloscope

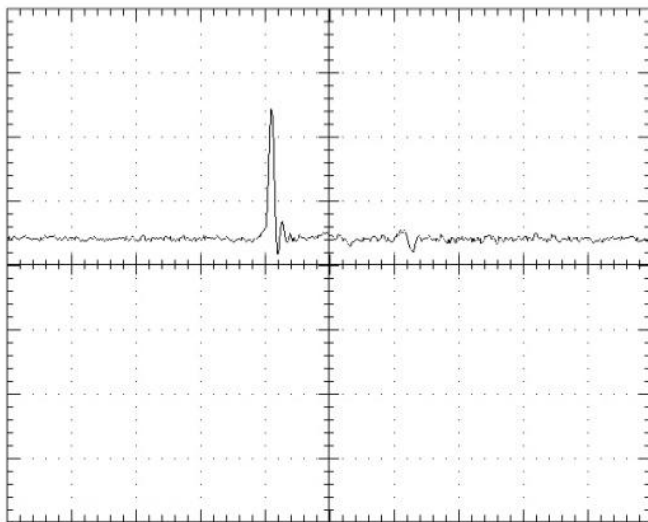

Figure E-2: Sample Start Diode Oscilloscope Image

If the start diode voltage is not at the appropriate level, ensure that the laser is fully warmed up (20-30 minutes) before making any adjustments to the start diode attenuator.