

JWST from below*

An overview of the construction of the James Webb Space Telescope, interesting metrology, and cryogenic-vacuum testing

University of Richmond

Richmond, Virginia
October 12, 2016

R. Ohl
Optics Branch
NASA Goddard Space Flight Center
raymond.g.ohl@nasa.gov
301 286 8368, 301 832 2546



*Apologies to R. Feynman ("Los Alamos from Below," *Reminiscences of Los Alamos, 1943—1945*, L. Badash et al. eds., D. Reidel Publishing Co., Dordrecht, p. 105, 1980).

- About NASA, about me
- Introduction to the James Webb Space Telescope and its mission
 - Hardware status
 - Measurement innovations --- many physicists work in the area of “metrology”
- Optical Telescope Element (OTE)
- Science Instrument (SI) and Integrated Science Instrument Module (ISIM)
- The focus of this talk is ISIM

JWST construction is well underway



NASA needs you!

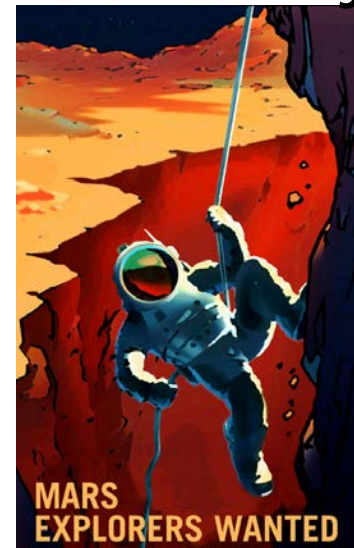

What is NASA?

- US Government's civilian "space department"
- Partners with industry and academia, but in-house work, too
- Space exploration
 - Human space flight and exploration
 - Robotic exploration
 - Astronomy and other space science
- Earth science
 - Weather
 - Climate change
- Airplane research
- NASA works closely with companies, universities, and other countries
- We are living in a "golden age" for astronomy and space science!
- We are on the cusp of a new golden age for human space flight!

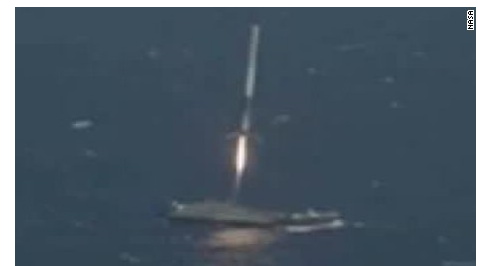
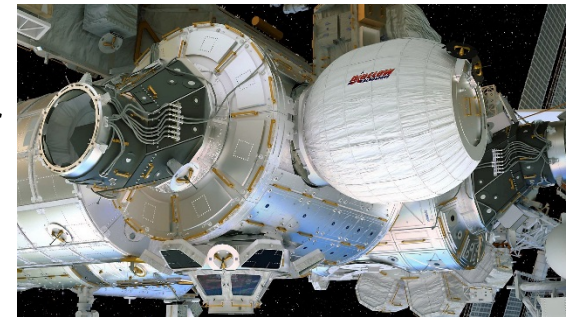
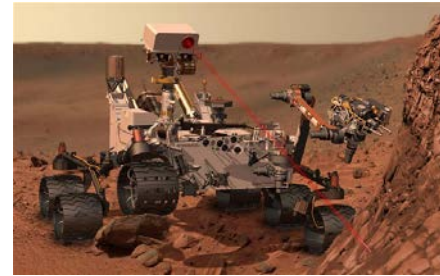



Who is this guy...?



- Born: Richmond, Virginia
- High school: Gettysburg, Pennsylvania
- College: **BS, University of Richmond, Richmond, Virginia, 1994**
 - Major: Physics (Dr. Vineyard, *Incomplete Fusion of ^{28}Si and ^{24}Mg Nuclei*)
 - Minor: Mathematics
 - University of Muenster, Muenster, Germany (*Westfaelische Wilhelms-Universitaet Muenster*)
- Graduate school: **University of Virginia, Charlottesville (Johns Hopkins University, Baltimore, and NASA Goddard Space Flight Center, Greenbelt)**
 - MA: Astronomy (populations of very hot stars)
 - PhD: Astronomy (instrumentation, hot star populations, stellar atmospheres)
- Titles:
 - Optical physicist/engineer, NASA Goddard Space Flight Center (~17 years)
 - Optical Engineering Lead, JWST science instruments and instrument + telescope assembly
 - Group Leader, Alignment, Integration, and Test Group, Optics Branch
- **What I do: Build instruments with astronomers (telescopes, cameras, spectrometers) --- I typically work on the construction/testing/calibration part of a given project.**
- **Why I work at NASA: NASA's science work is strongly driven by an agenda that address questions like "how did we get here" and "are we alone in the universe" and topics like the health of our planet --- this is a peaceful, high-karma undertaking that can keep one motivated and focused. This job keeps me learning (challenging; excellent colleagues).**
- Hobbies:
 - Part-time teaching: Optics for graduate students in Applied Physics (Engineering for Professionals, Whiting School of Engineering, Johns Hopkins University)
 - Sailing, swimming, running

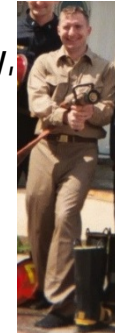

George and Emily (and JWST)

Family and Thomas Point Light from the cruiser, *Take Luck*





How I got to NASA Goddard and what I do there



- Interest in working for NASA in space exploration from a young age (early elementary school)
- Always a big science fiction fan
- Started to narrow my focus in high school toward physics
- College:
 - Undergraduate research in particle physics at U. of R.
 - Small school; one-on-one attention; excellent preparation for graduate school in physics
 - Lots of student research opportunities (good background for grad school and industry jobs)
 - Liberal arts background has been invaluable (writing, leadership, language, etc.)
 - Summer student at NASA Kennedy Space Center (saw multiple Shuttle and rocket launches; worked on manned space flight “life science” projects) --- undergrad is a great time to try different fields
- Graduate school (Master’s):
 - Funded by NASA and teaching
 - Worked on NASA’s *Astro-1 and 2 Space Shuttle* missions (ultraviolet telescopes flown in space)
 - Taught undergraduate astronomy classes with professors (teaching assistant)
 - Taught an undergraduate astronomy class at a community college
- Graduate school (PhD):
 - Funded by NASA through a contract to JHU to build an ultraviolet telescope / satellite
 - Worked on optical testing, assembly, ground testing, ground test software, ground test electronics, etc. for NASA’s *Far Ultraviolet Spectroscopic Explorer (FUSE)* mission
 - Worked on science data from hot stars and galaxies of hot stars
- After working closely with NASA engineers and scientists from GSFC, encouraged to apply for an engineering opening at NASA GSFC after graduation from UVA



Astro-1 & 2 Space Shuttle missions

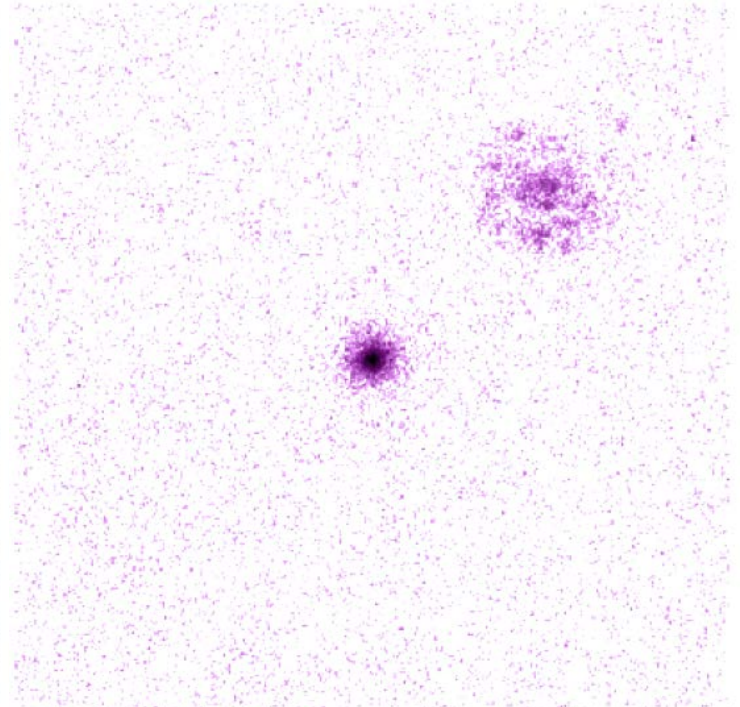
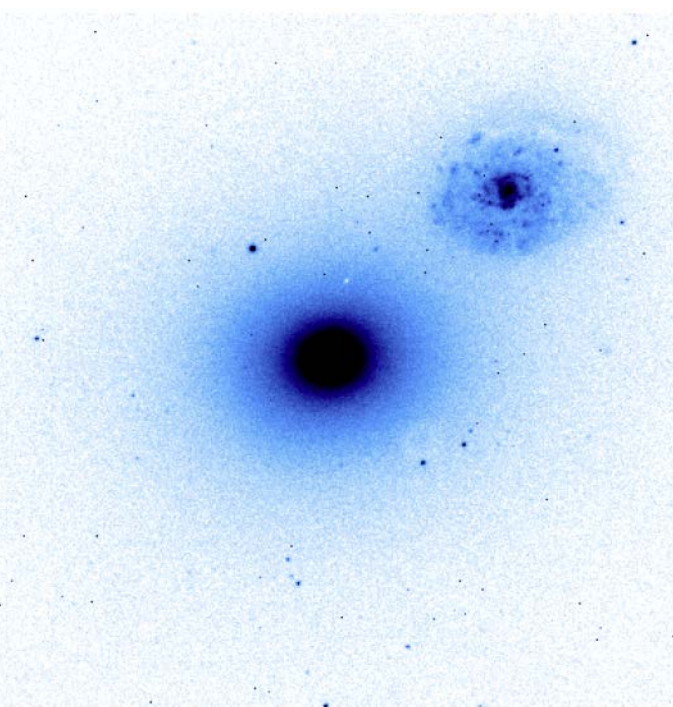
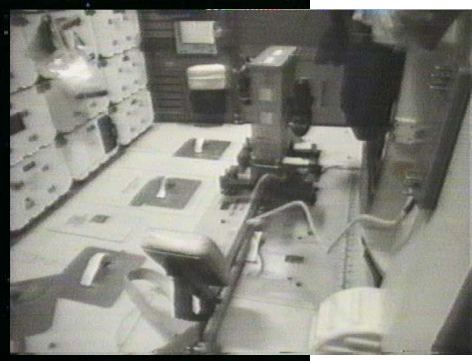
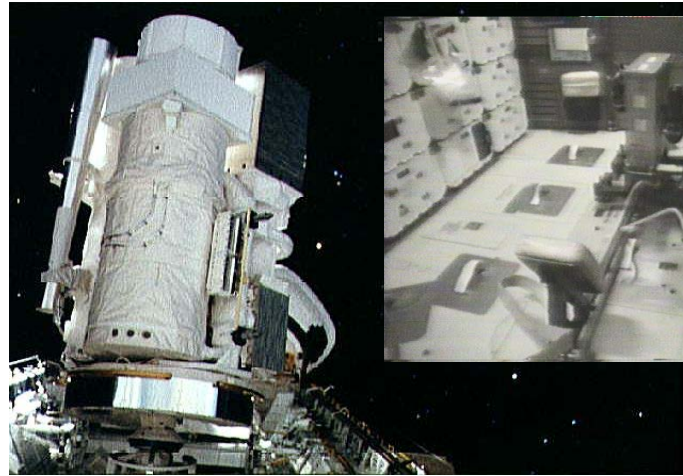
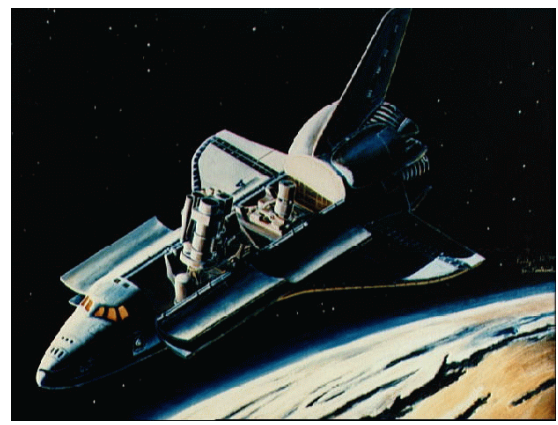

NASA FUSE mission

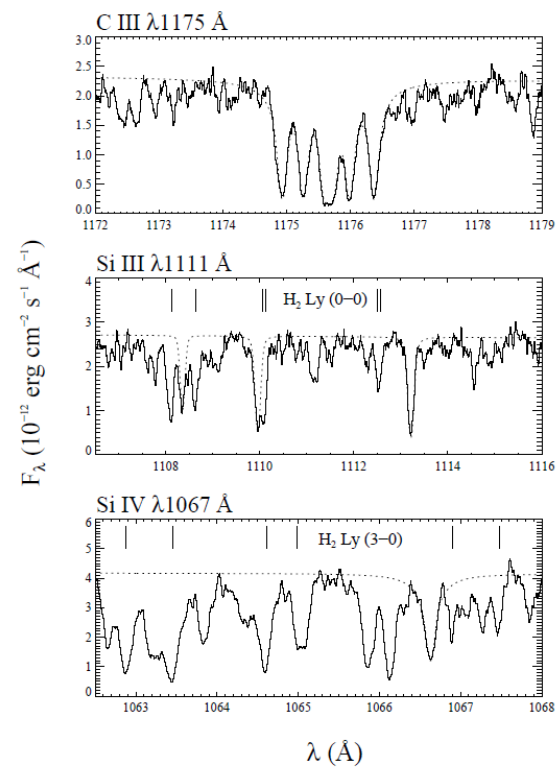
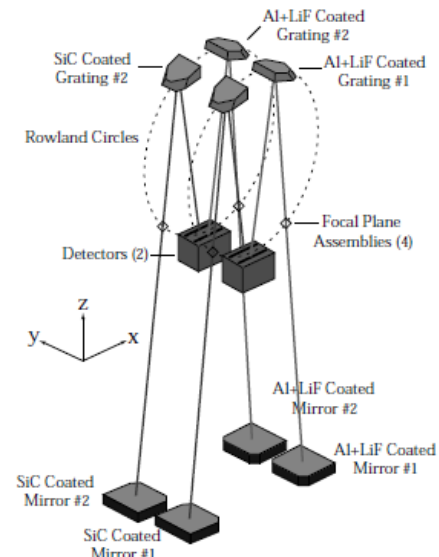
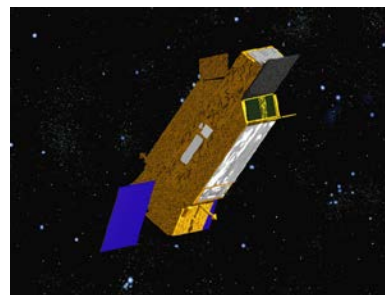
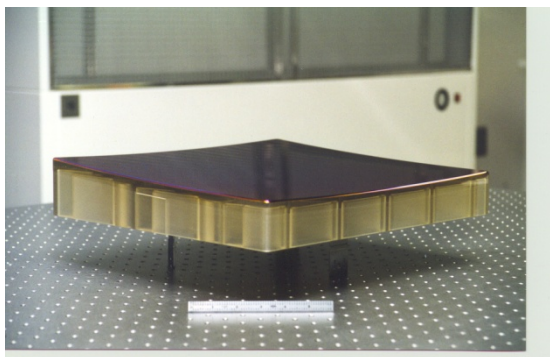
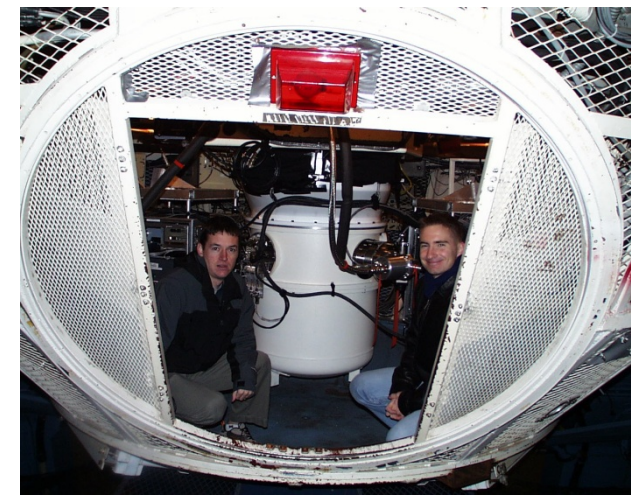
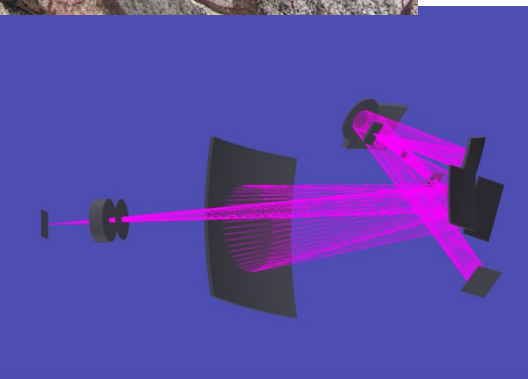
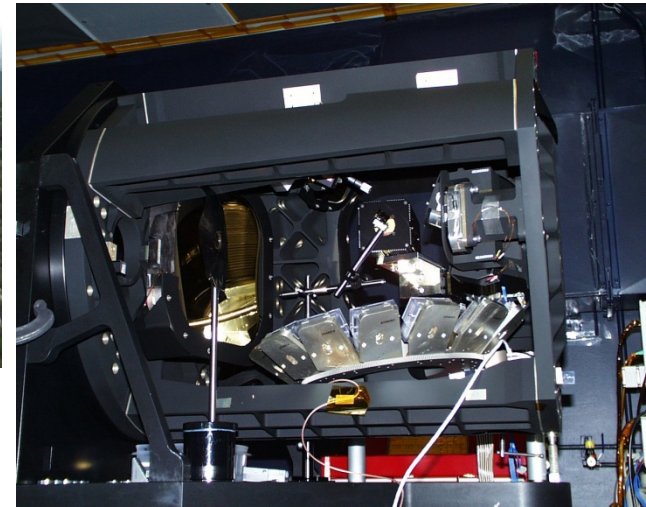

Figure 42: *FUSE* spectra (solid line) and absorption line fits (dotted line) used to determine the C and Si abundances listed in Table 9. Note the location of the Lyman transitions of H_2 used to help correct the wavelength scale for S III and S IV.



Ground-based, infrared spectrometer





Future telescope mission studies/concepts (e.g., Terrestrial Planet Finder)

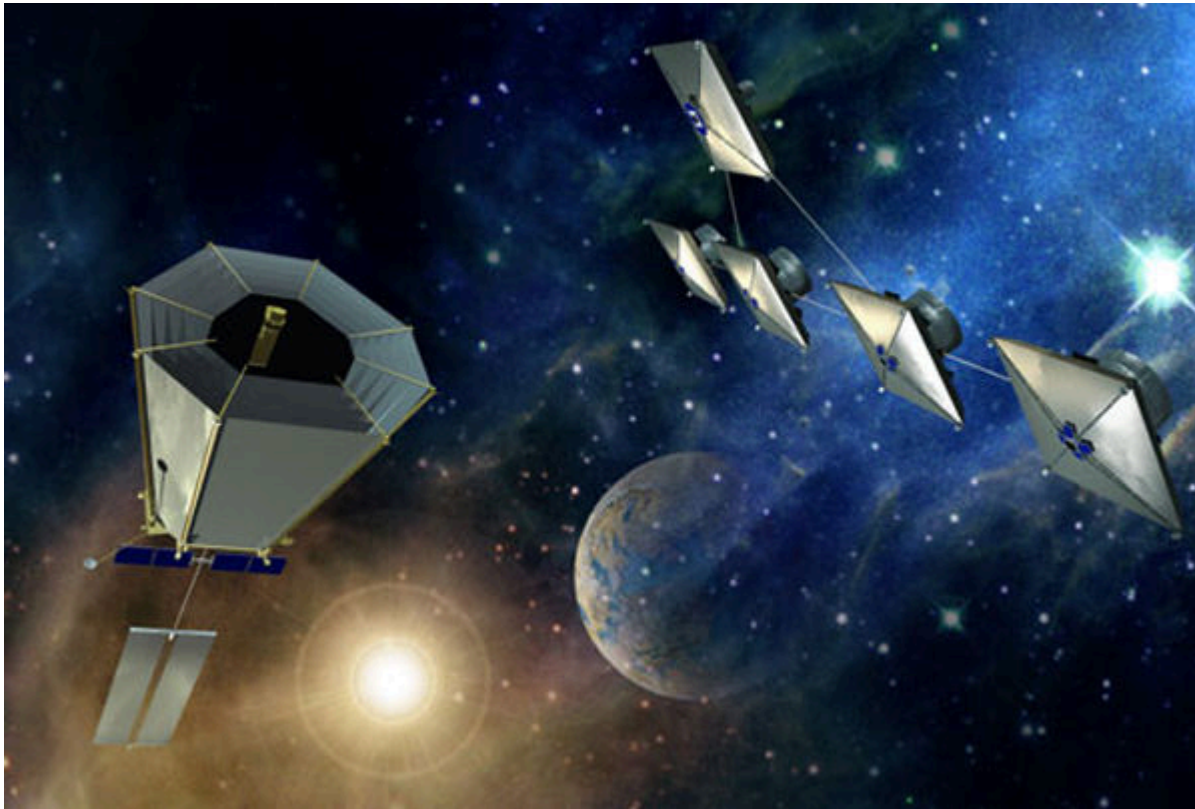



James Webb Space Telescope (JWST)



WEBB
TELESCOPE





JWST is a general astrophysics mission



- JWST will operate in a manner similar to HST to enable a wide range of science investigations proposed by astronomers world-wide
- General Observer community will drive science investigations
- Four science themes define the development of technical requirements for JWST:
 - First light and reionization: Identify the first bright objects in the early Universe and follow ionization history
 - Galaxy formation and evolution: Shed light on how galaxies and dark matter evolved to present
 - Star formation in our galaxy: Study the birth and early development of stars
 - Planetary systems: Observe the physical and chemical properties of solar systems (including our own)

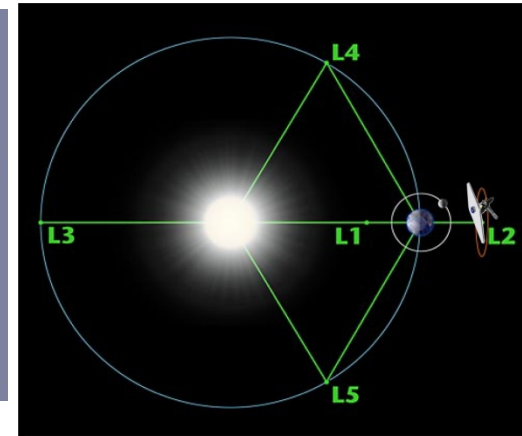
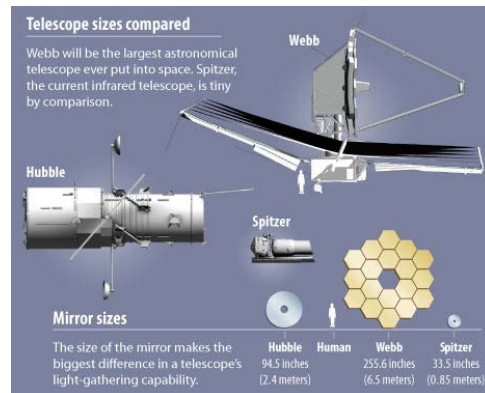
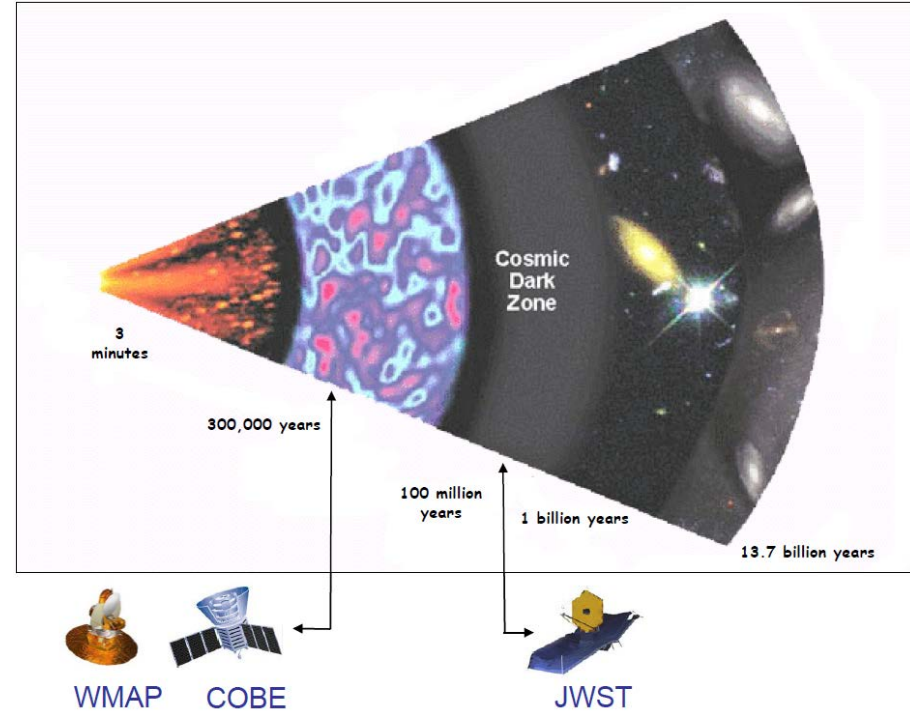



JWST Observatory Elements and Regions



Integrated Science Instrument Module (ISIM)
 - Located inside an OTE provided ISIM Enclosure
 - Contains 4 Science Instruments (NIRCam, NIRSpec, MIRI, FGS / TF)

Thermal Region 2
 - Components maintained at ambient temperatures on cold side of the observatory

ISIM Electronics Compartment (IEC)

OTE Backplane / ISIM Enclosure

Optical Telescope Element (OTE)
 - 6 meter Tri-Mirror Anastigmatic
 - 18 Segment Primary Mirror

Thermal Region 1
 - Components cooled to cryogenic temperatures

OTE Secondary Mirror

OTE Primary Mirror

OTE Deployment Tower

Sunshield (SS)
 - 5 layers to provide thermal shielding to allow OTE and ISIM to passively cool to required cryogenic temperatures

Solar Array

Thermal Region 3
 - Components maintained at ambient temperatures

Spacecraft Bus
 - Contains traditional "ambient" subsystems

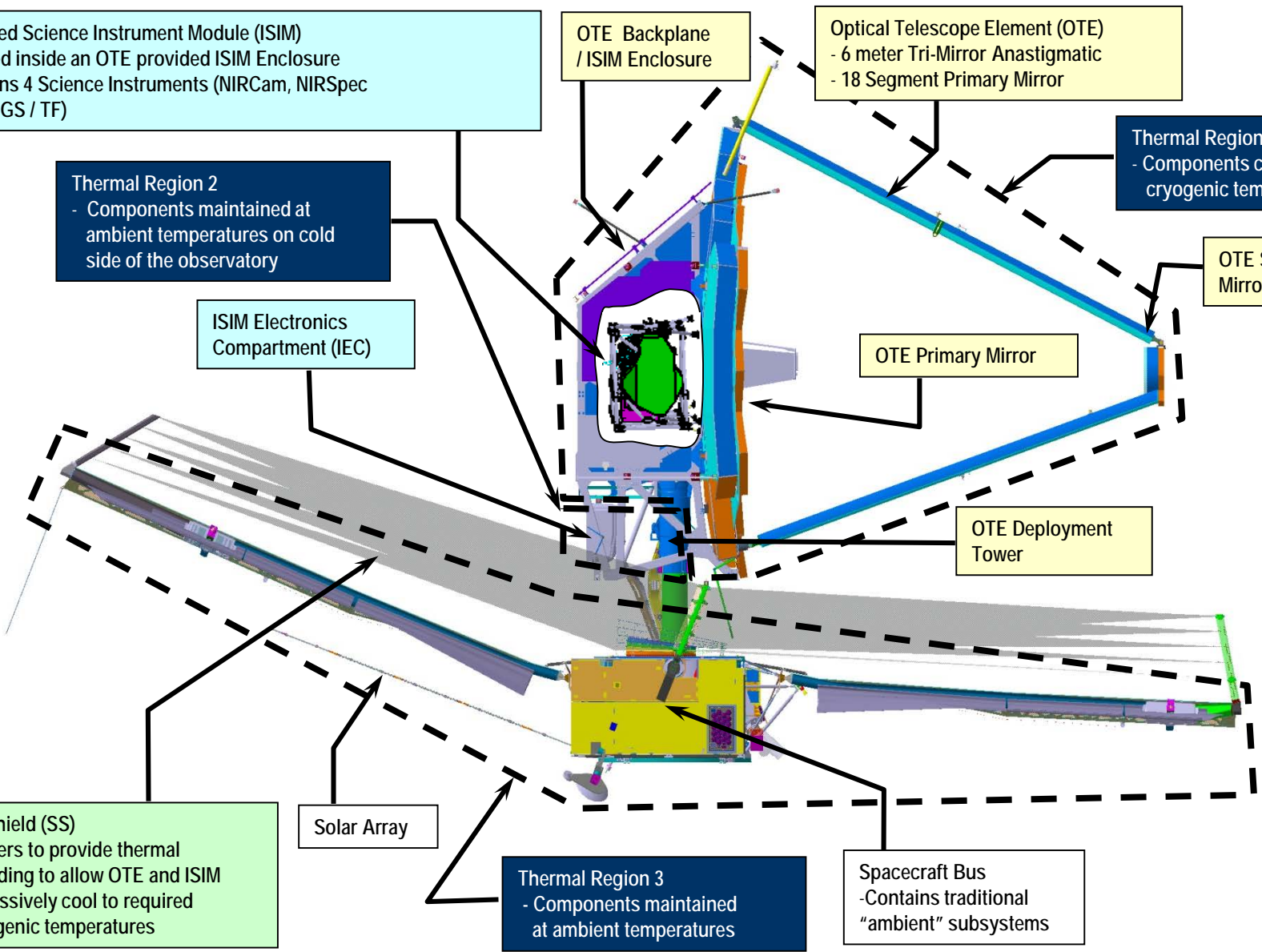



Optical Telescope Element (OTE)

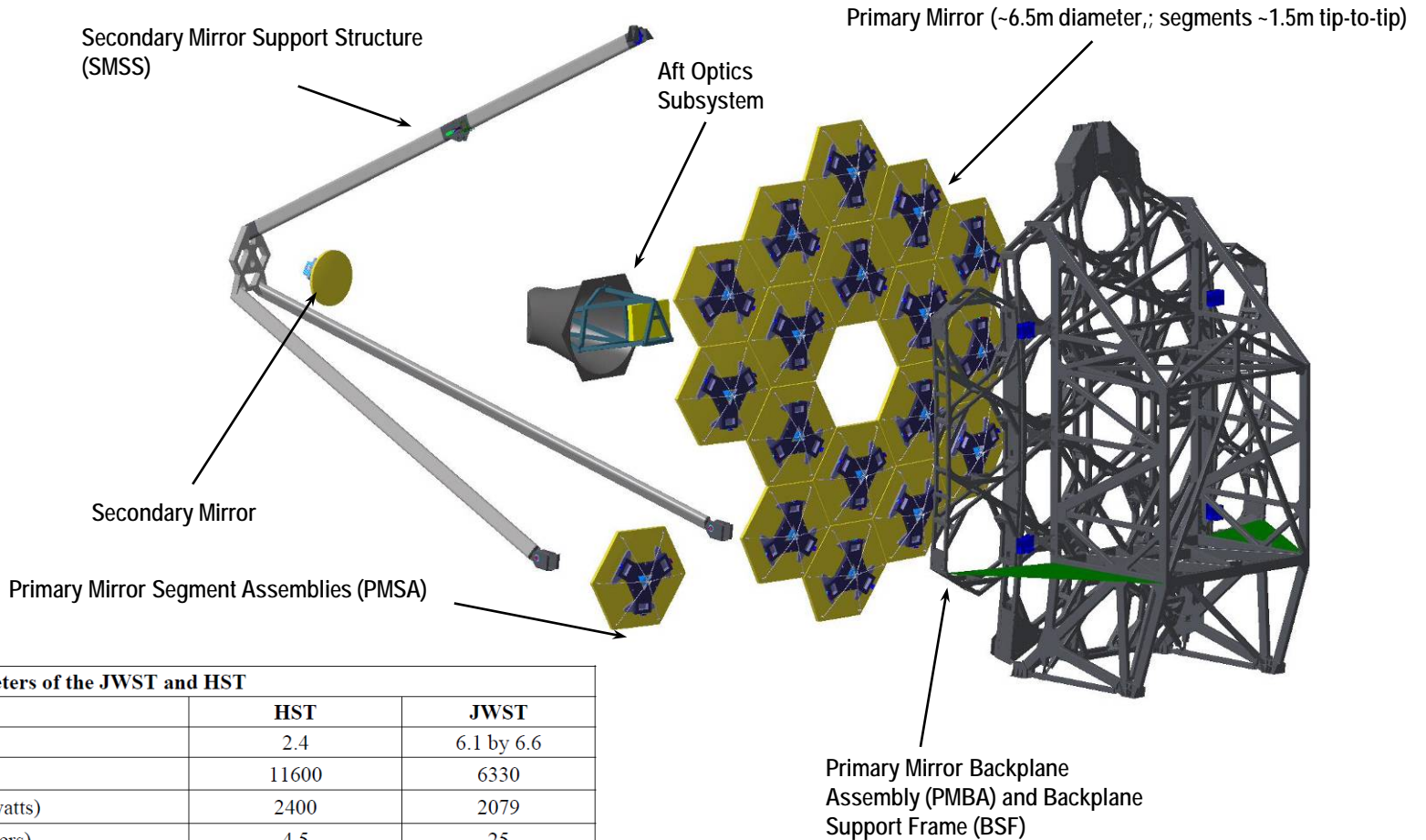

- Composite tube frame construction
- Two deployable Wings

Table 1: Key design parameters of the JWST and HST

Performance Parameter	HST	JWST
OTE Diameter (meters)	2.4	6.1 by 6.6
Mass (kg)	11600	6330
Output power at load input (watts)	2400	2079
Unobscured Aperture (sq meters)	4.5	25
Overall optical transmission (%)	45 to 25	62 to 43
Telescope field of view (arc min)	14.6 (radius)	18 by 9
Wavelength of diffraction limited performance	0.5	2
Rayleigh radius (arc sec)	0.043	0.069
Telescope Strehl ratio (%)	80	80
Pointing accuracy without fine guidance (arc sec)	22	7
Pointing stability with fine guidance (arc sec)	0.007	0.007
Detector pixels (Mega Pixels)	25	66
Data volume (Gbits/day)	27	458



Structure stability: Backplane Stability Test Article (BSTA) and speckle interferometry

- Structure required to be stable to ~nm level over temperature excursions
- BSTA developed as test article representative of portion of structure
- Vibration-insensitive Electronic Speckle Pattern Interferometry (ESPI) developed to measure nm-level changes in large, non-specular, mechanical surfaces over time, temperature, etc. by tracking speckle motion on the surface
- GSFC and STScI personnel
- Partnership with 4-D Technology, ATK, NGAS, and NASA MSFC
- B. Saif et al., Applied Optics 46 and 47, 2007

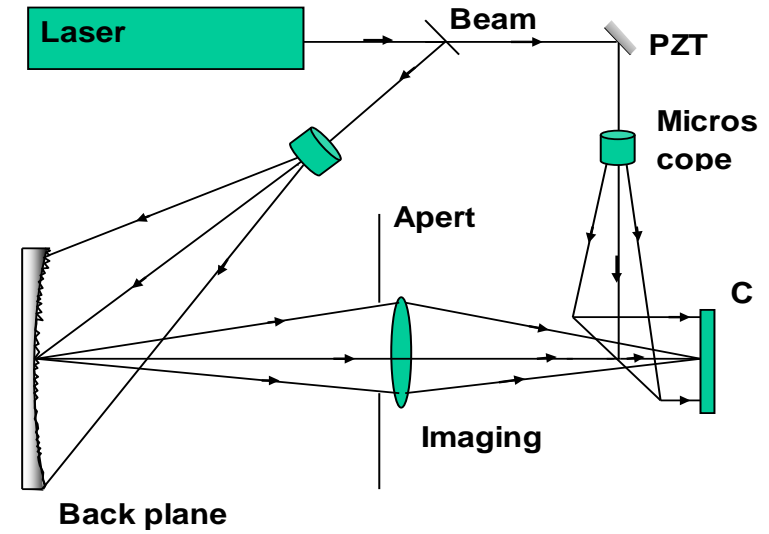
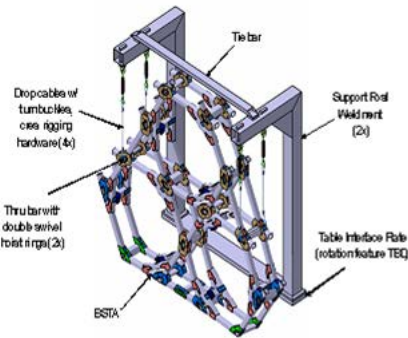
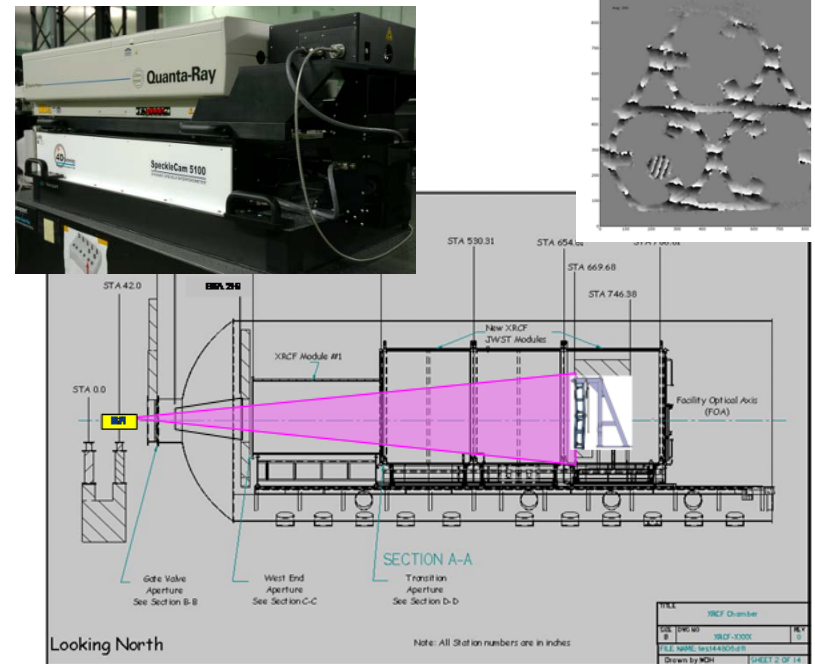

Fig.. Electronic Speckle Interferometry of PM



ESPI-BSTA test configuration at NASA MSFC





JWST Mirror Development History

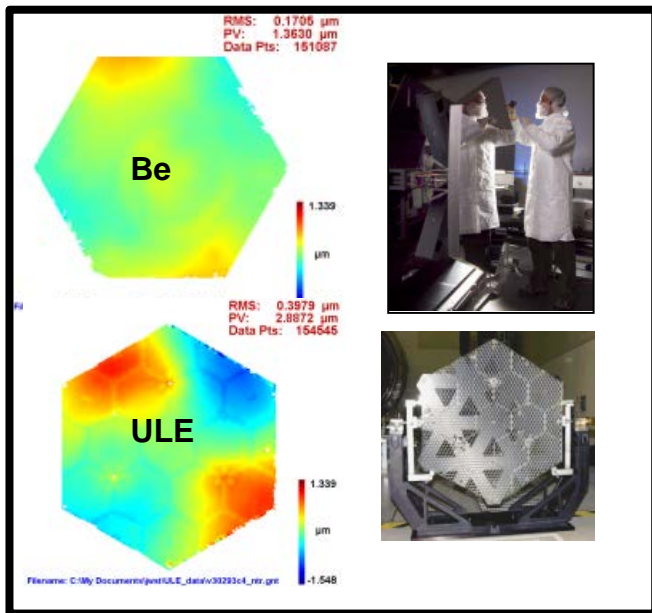

• NASA HST, Chandra, SIRTf Lessons Learned
 - TRL 6 by NAR
 - Implement an active risk management process early in the program (Early investment)

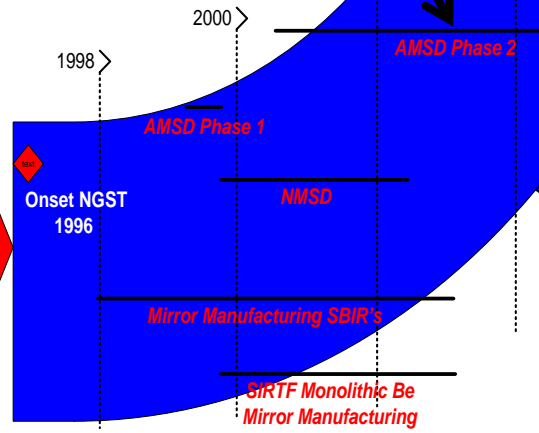

L. Feinberg, AAS, Jan 2010



Primary mirror segments tested at NASA MSFC in XRCF chamber (Chandra/AXAF)

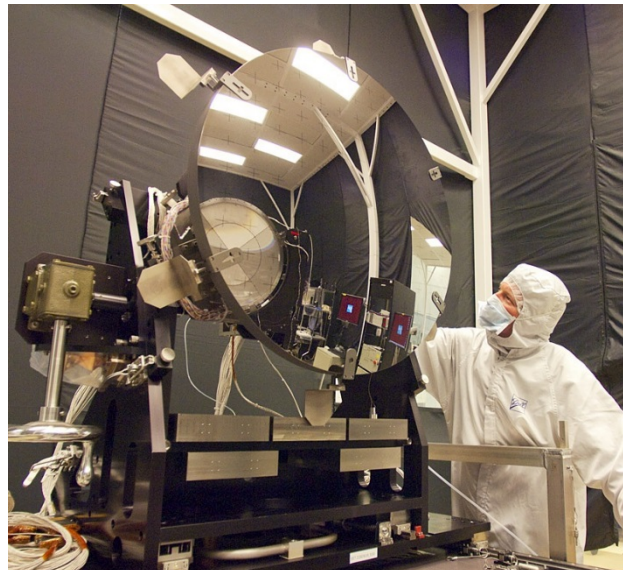
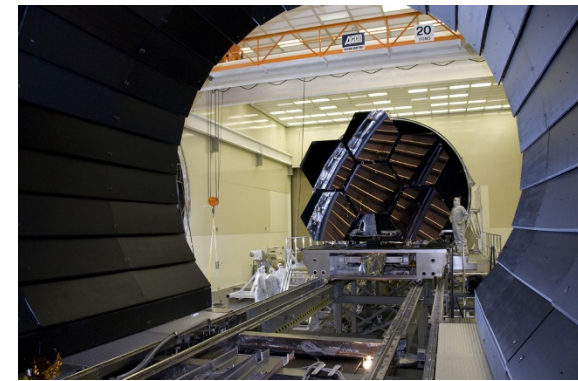
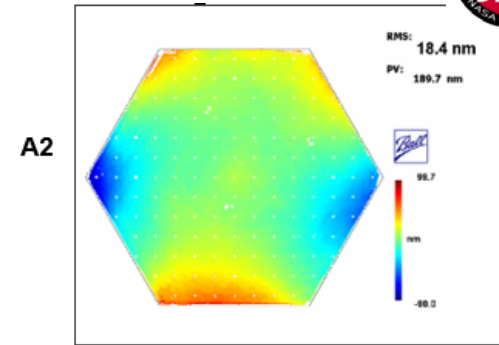
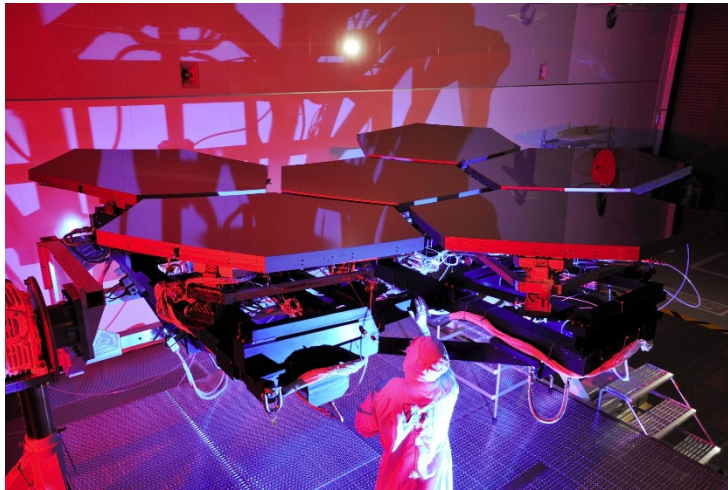



Ambient metrology tools: Laser trackers & radars and theodolites



Laser tracker¹ is used to measure targets and surfaces

- Interferometric measurements of change in distance
- “absolute distance meter” measures range (from time of flight) based upon signal modulation (polarization; 780 nm)
- Operated with Spatial Analyzer² software, which includes Unified Spatial Metrology Network (USMN; bundling) routine --- greatly improved uncertainty
- Its target is a spherically mounted retro-reflector (SMR)
- Uncertainty ~0.005--0.025 mm (1-sigma)
- LT may be used with T-Cam / T-Scan / T-Probe accessories to measure envelopes, surfaces, tooling holes



Laser tracker

Polarization Modulation
systematical change of the beam shift by an electronic oscillation circuit

high frequency 700 - 900 MHz

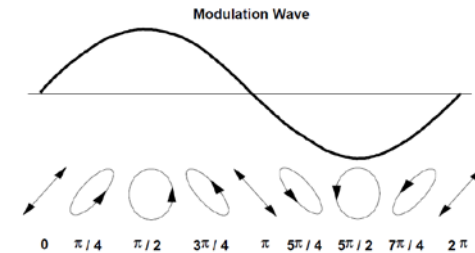

SMR

Theodolites are used to measure angles via auto-collimation

- Operated manually, data is analyzed with GSFC-developed software
- Autocollimation: Target is a specular flat mirror (cube)
- Uncertainty ~2 arc-sec (1-sigma) for a single measurements, >5 arc-sec (1-sigma) for a collection of measurements



T-Scan



1. Leica Geosystems AG, Heerbrugg, Switzerland, metrology.leica-geosystems.com
2. New River Kinematics, Inc., Williamsburg, Virginia, www.kinematics.com



Theodolite



“Laser radar”



Laser radar¹ (LIDAR) is used to measure targets and surfaces

- Laser is modulated in frequency; return beam suffers a modulation shift with time of flight & range (1.55 μm)
- Operated with Spatial Analyzer software
- Its target is diffuse surface (mechanical surface; matt finish), reflective tooling ball, specular mirror, or high-quality tooling hole
- Uncertainty ~ 0.015 mm in range (1-sigma), ~ 0.015 mm per meter in azimuth and elevation (1-sigma)
- Laser Radar scans much faster than Laser Tracker with T-Probe
- USMN-compatible
- At ambient, used for:
 - Used for prescription and alignment measurement for large optics (radius, aperture, etc.)
 - Envelope scans
 - Tooling ball targets on large assemblies
 - Large mirror prescription
- Cryogenic use:

Measurement through a chamber window

Laser radar (LIDAR)

1. Nikon Metrology, Brighton, Michigan and Manassas, Virginia

“ ΔF ” has a direct relationship to “ ΔT ” but is far easier to measure.

ΔF : Difference in frequency between transmitted and received signal.
 ~ 0.58 Hz change is equivalent to 1 micron of range change [$575 \text{ kHz/m} \times \Delta \text{Range}$]

ΔT : Difference in time between transmitted and received signal
 $\sim 6.7 \times 10^{-15}$ sec is equivalent to 1 micron of range change [$2 \times \Delta \text{Range} / c$]

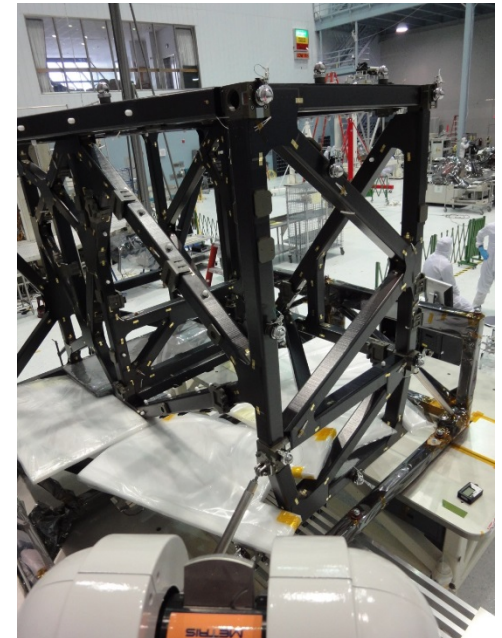
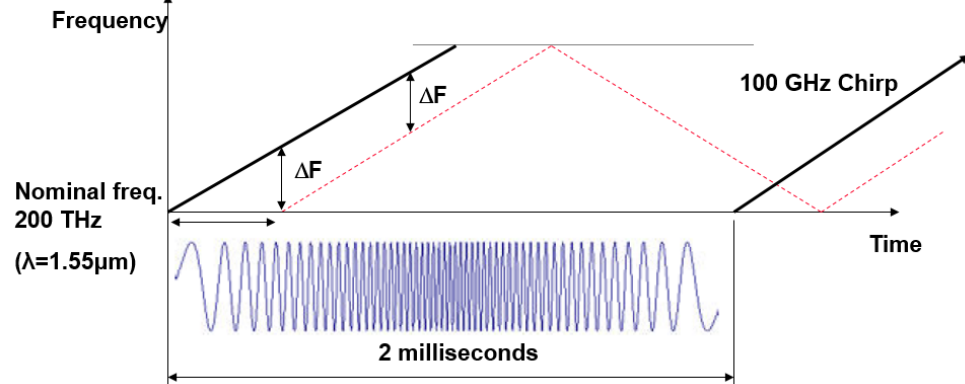



OTE build-up at NASA Goddard (Harris Corp. & GSFC)



- Mirror metrology
- Integration and alignment

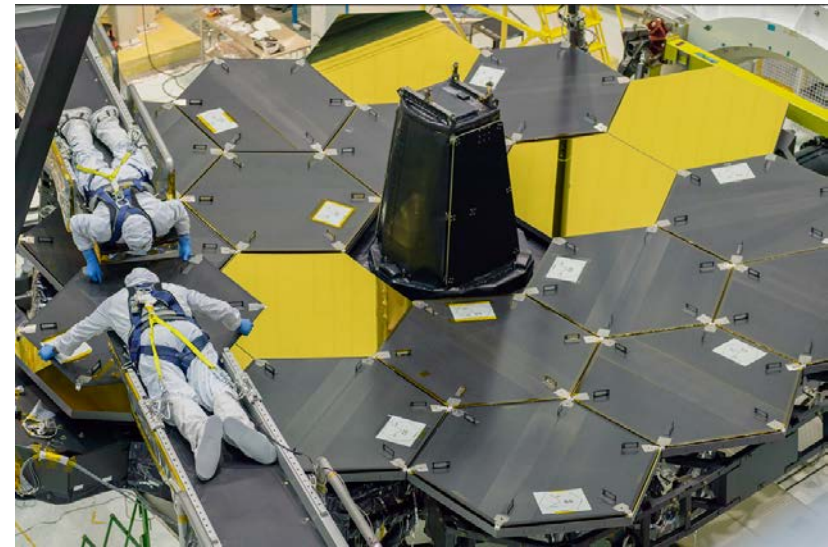
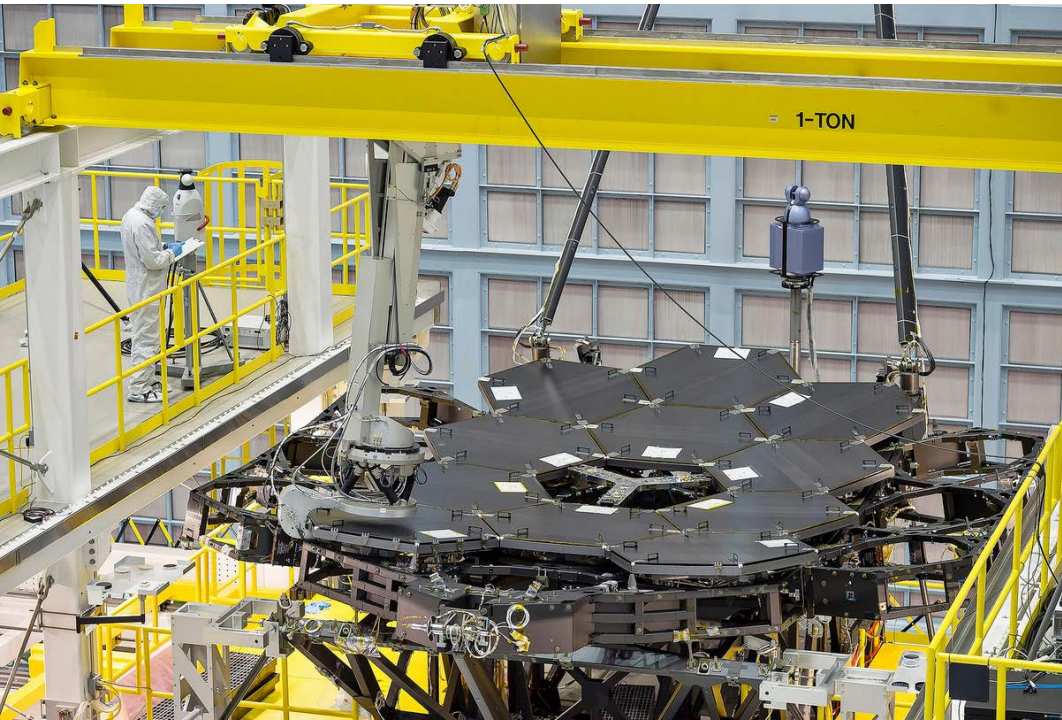
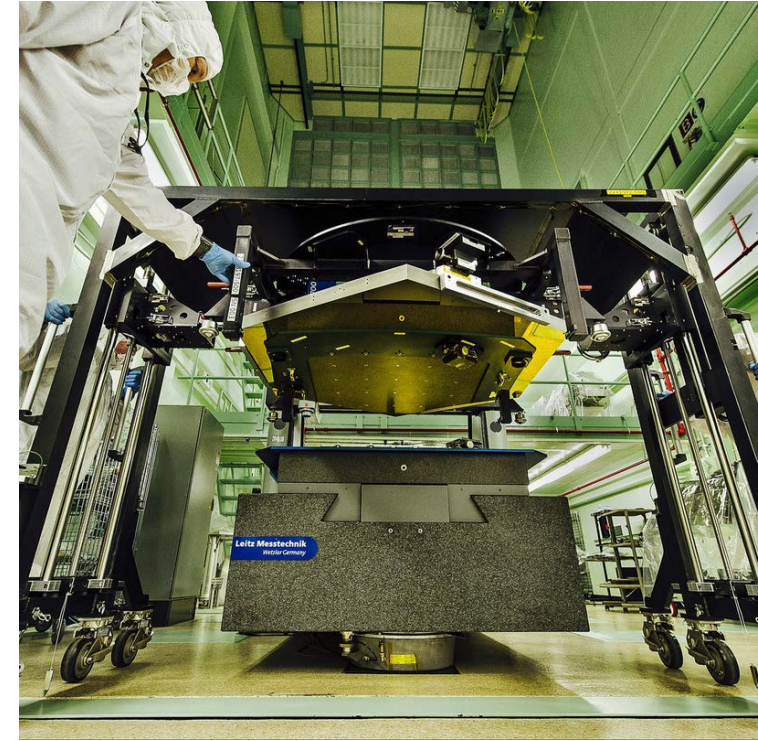

Integrated Science Instrument Module (ISIM)

- Housed behind the primary mirrors
- Aligned to exit pupil and focal surface of telescope

Four Instruments on ISIM

- **Near-Infrared Camera (NIRCam)**
- **Near-Infrared Spectrometer (NIRSpec)**
- **Mid-Infrared Instrument (MIRI)**
- **Near-InfraRed Imager and Slitless Spectrograph (NIRISS)**

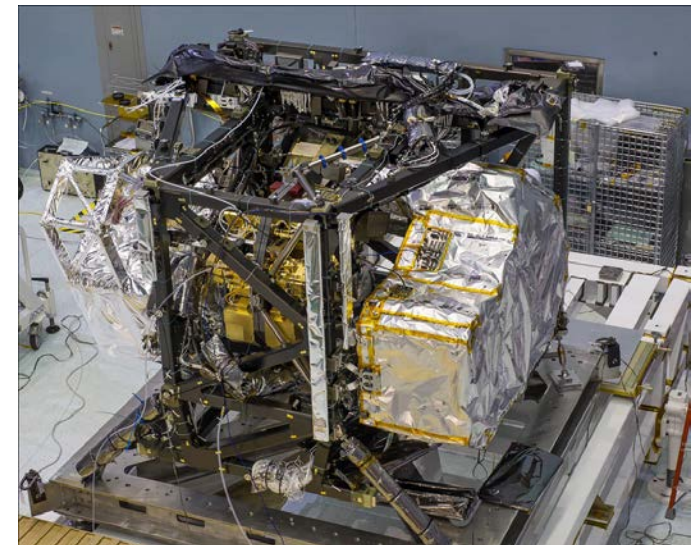
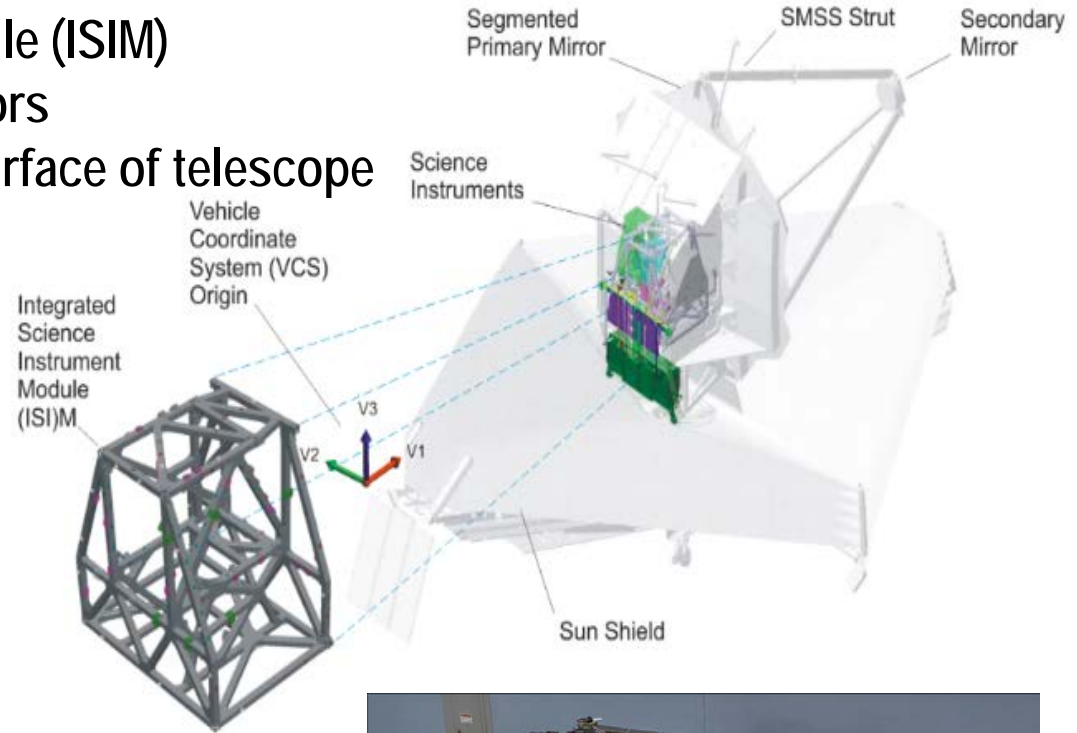

ISIM alignment and performance parameters

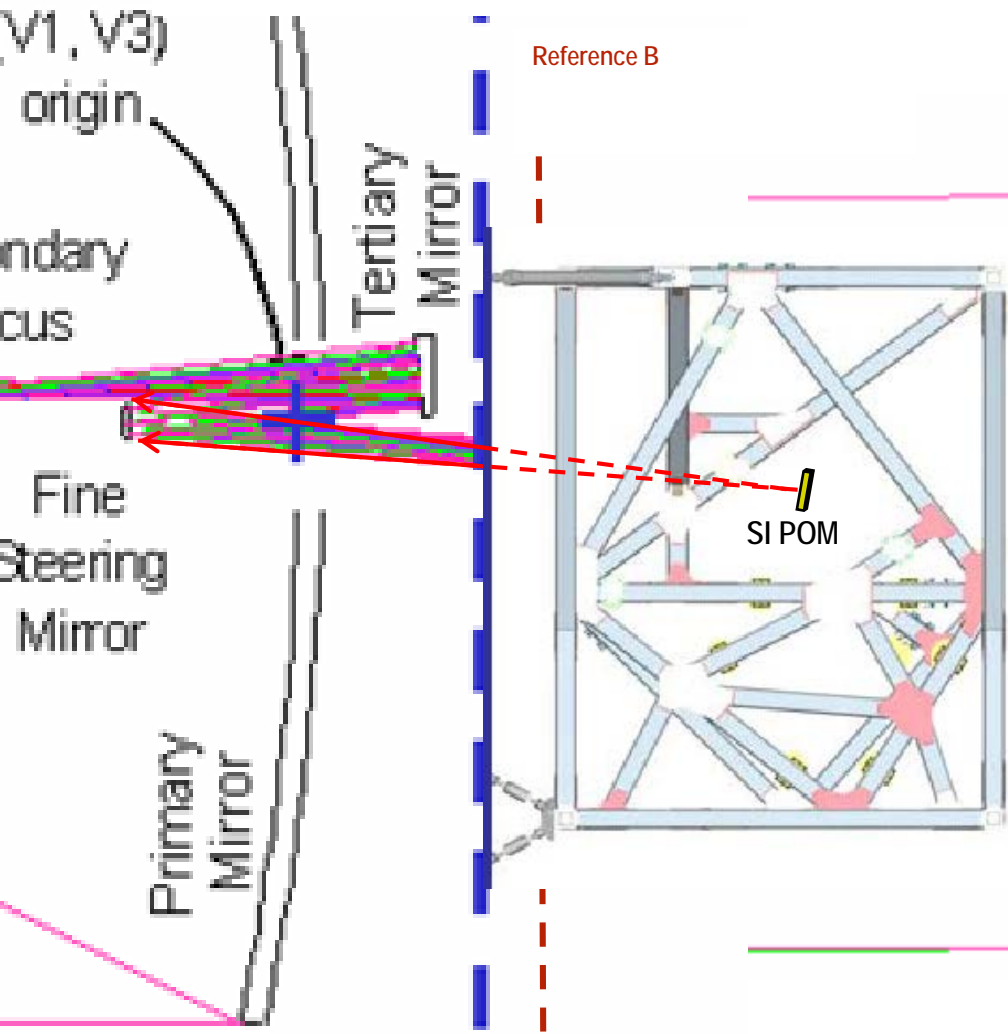

Misalignments and resulting performance errors

- V1 changes best focus
- V2/V3 changes boresight
- V2/V3 yields SI entrance pupil shear vs OTE exit pupil
 - 1 mm shift = 1.56 arcsec shift in sky angle, 1/6th of 10.2 arcsec requirement
 - 1 mm shift = 0.66% shear, 1/5th of 3.1% requirement
 - V2/V3 alignment errors < 0.05 mm
- Rotation about V2 or V3 shears the SI entrance pupils vs the OTE exit pupil
 - 1 arcmin error = 0.59% shear
 - rV2/rV3 alignment errors < 0.2 arcmin

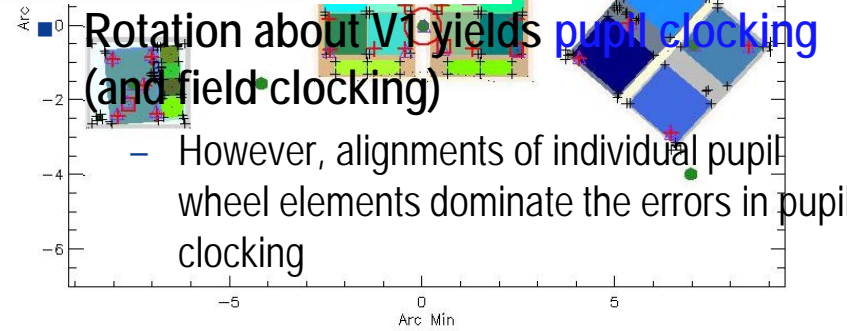

ISIM Calibration

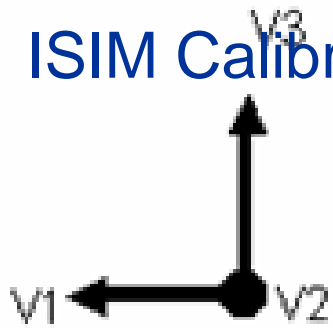

Secondary Mirror

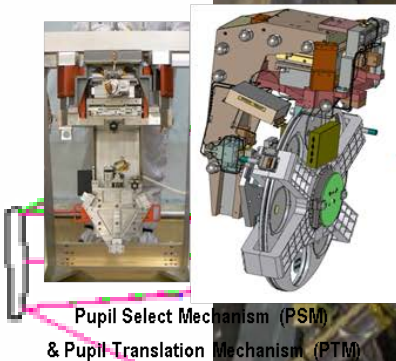

Pupil Select Mechanism (PSM) & Pupil Translation Mechanism (PTM)



Fold Mirror 3 Tip/Tilt Gimbal Assembly



Alignment Diagnostic Module (ADM)



Pupil Imaging Module (PIM)

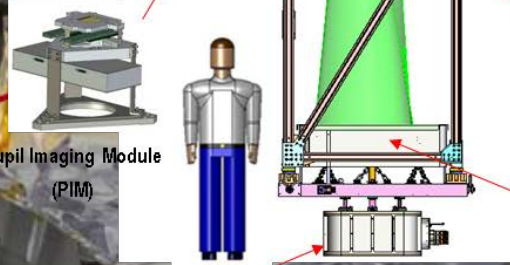

NIRCam

NIRSpec

MIRI

Reference A

Reference B



Source Plate Mechanism (SPM)



Fold Mirror 1



Fold Mirror 2



Primary Mirror (PM)



Optical Bench (OB)

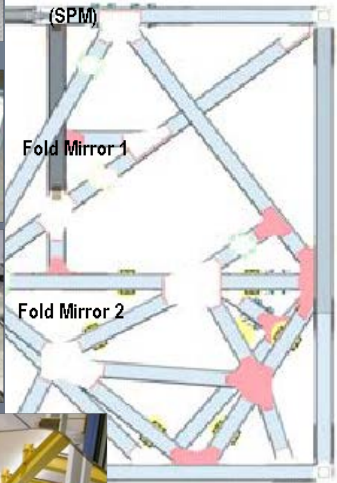



JWST ISIM integration and test flow chart

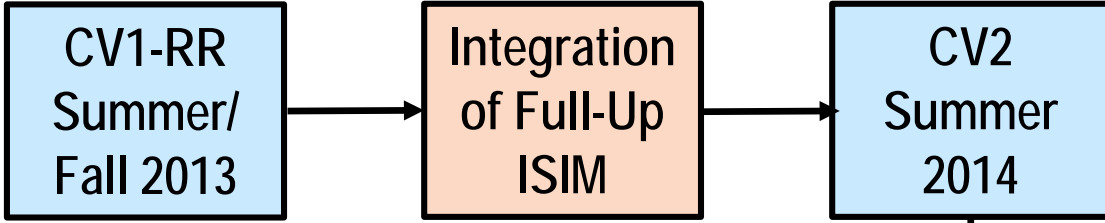

Science Instrument Final Upgrades

<p>FGS:</p> <ul style="list-style-type: none"> • Detector arrays • Electronics boards 	<p>NIRISS:</p> <ul style="list-style-type: none"> • Detector array • Grisms • Dual Wheel motors 	<p>MIRI:</p> <ul style="list-style-type: none"> • Flight HSA boards • Electronics boards 	<p>NIRCam:</p> <ul style="list-style-type: none"> • 3 of 10 detector arrays • Electronics boards 	<p>NIRSpec:</p> <ul style="list-style-type: none"> • Detector arrays • MicroShutter Array • Electronics board
--	---	---	---	---

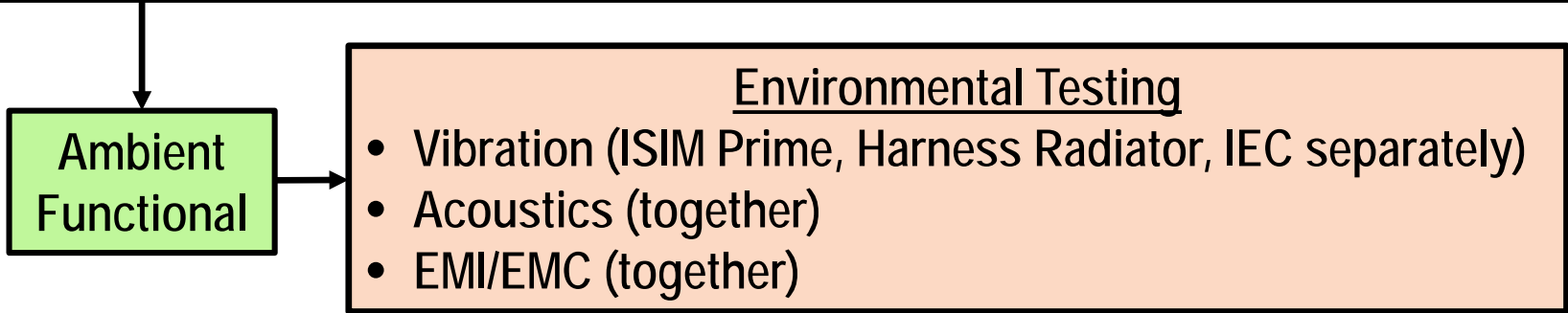

Photogrammetry is used to measure target positions

- Customized system developed for NASA/GSFC
- Uses COTS camera* housed in custom canister that holds the camera in ambient temperature and pressure environment within a larger vacuum chamber and cryogenic environment
- Operated with V-STARS* software
- Its target is a retro-reflective surface with a precision mask
- Targets measured from many vantage points to determine location via triangulation
- Uncertainty ~ 0.010 mm (1-sigma; highly dependent on test configuration)



PG camera



PG targets



PG scale bar

Alignment Diagnostic Module (ADM)

- Leica Absolute Distance Meter measures the positions of retro-reflectors
- Alignment telescope with custom reticule measures back-illuminated pin hole or fiber positions or autocollimates on specular flat mirrors
- Sights along optical axis of OSIM
- Enables in situ 6 DoF alignment measurements of OSIM components, GSE, and ISIM Structure
- Internal components held at ambient temperature and pressure

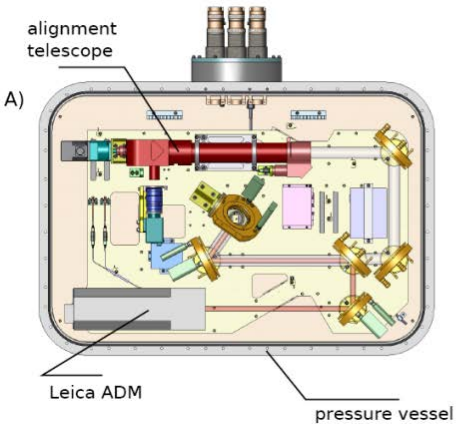

A. ADM schematic. B. Image of assembled ADM.
Sabatke, von Handorf & Sullivan, Proc. SPIE 7461, 2009

*Geodetic Systems Inc., Melbourne, Florida

 ISIM Structure (composite tubes and Invar joints)

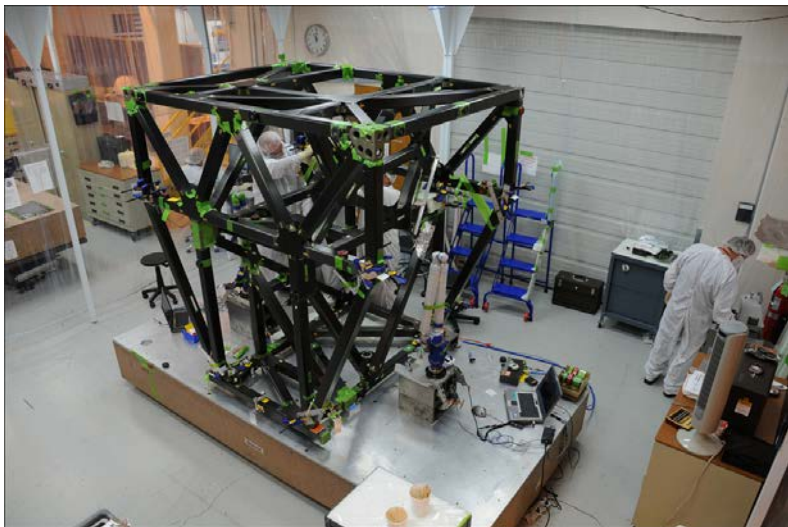

Structure bonding at ATK (Utah)

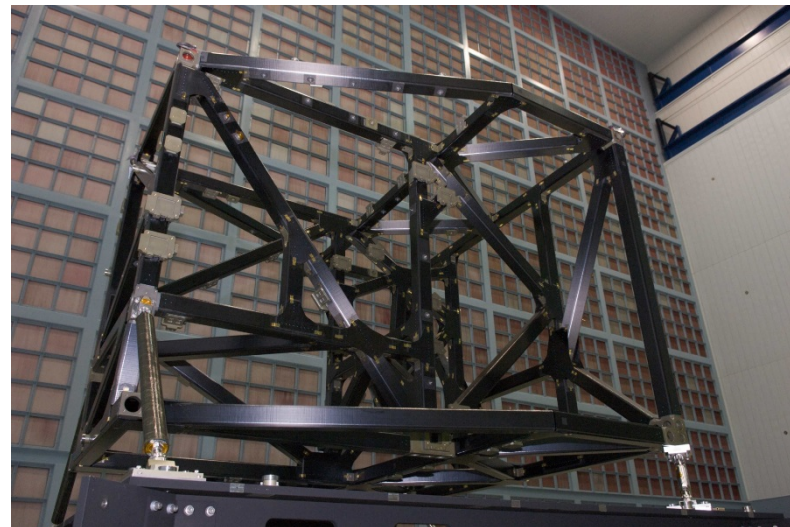

Structure on kinematic mounts (from Harris)

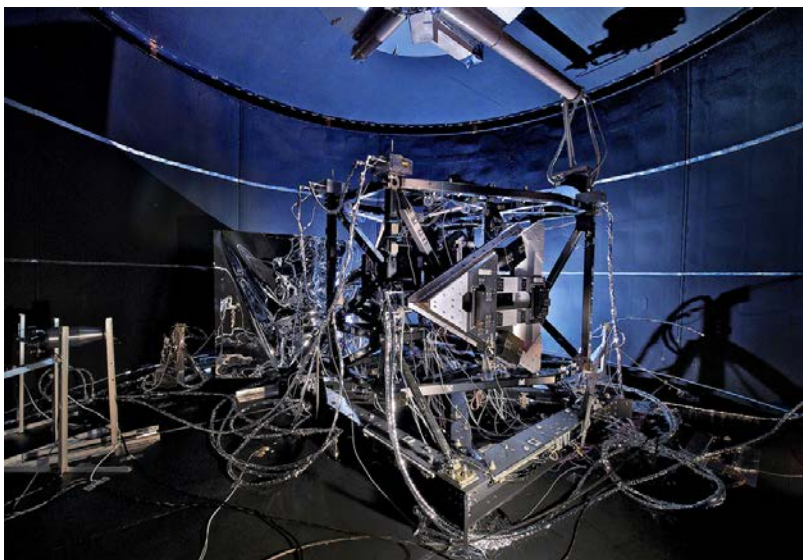

Structure cryogenic metrology testing (PG)



Integration of science instrument optical assemblies

NASA Characterizing & customizing the ISIM Structure

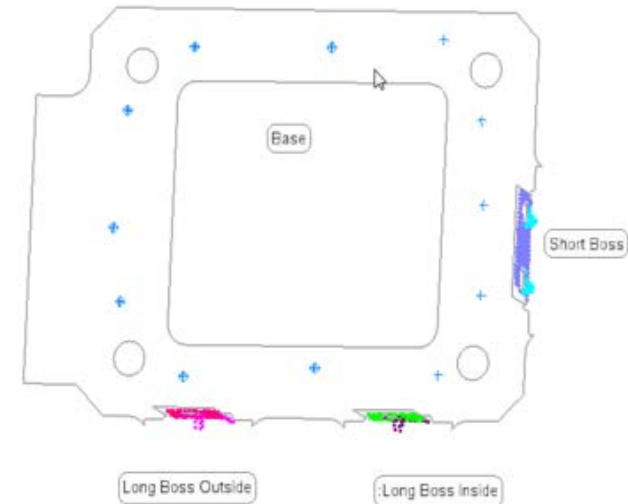
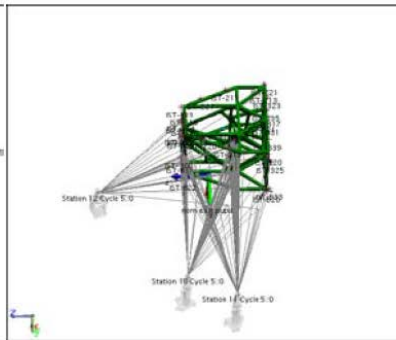
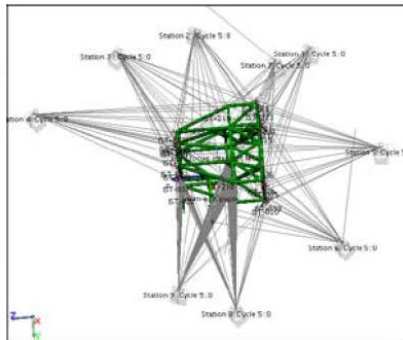
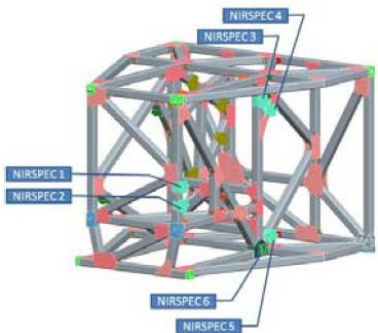
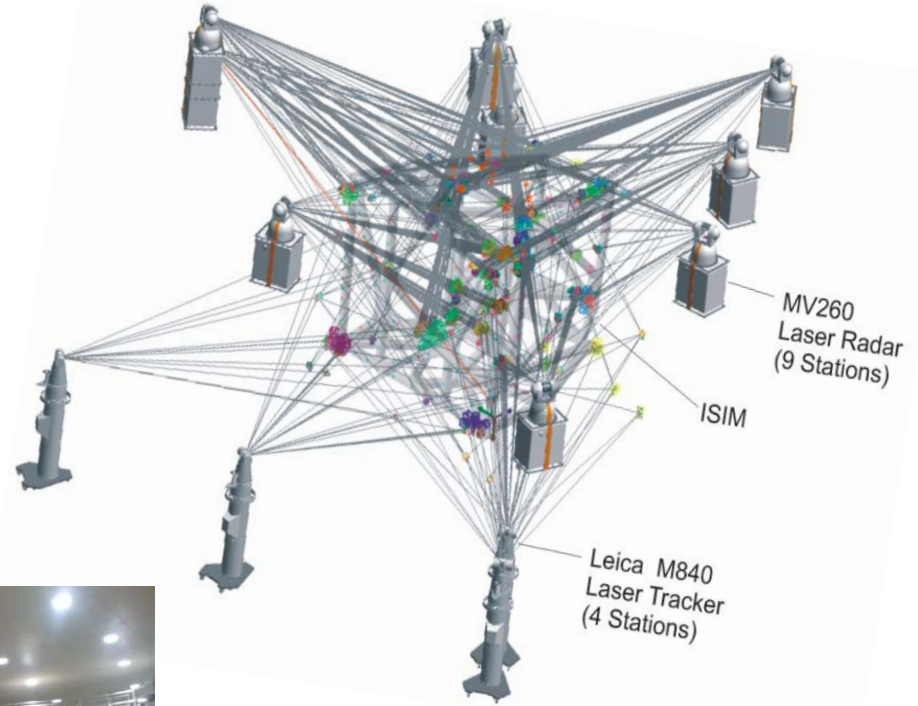
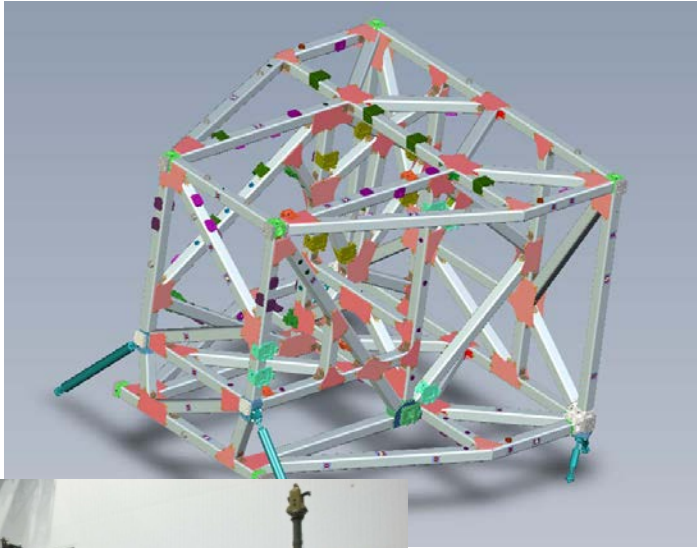



Cryogenic-vacuum test of Structure

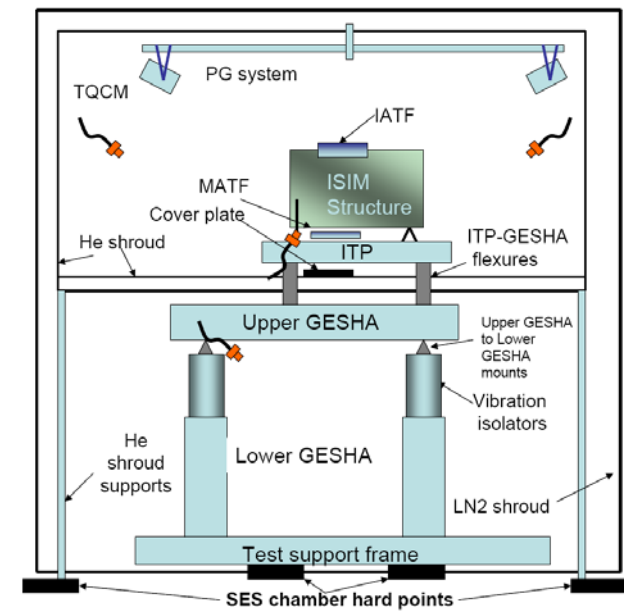
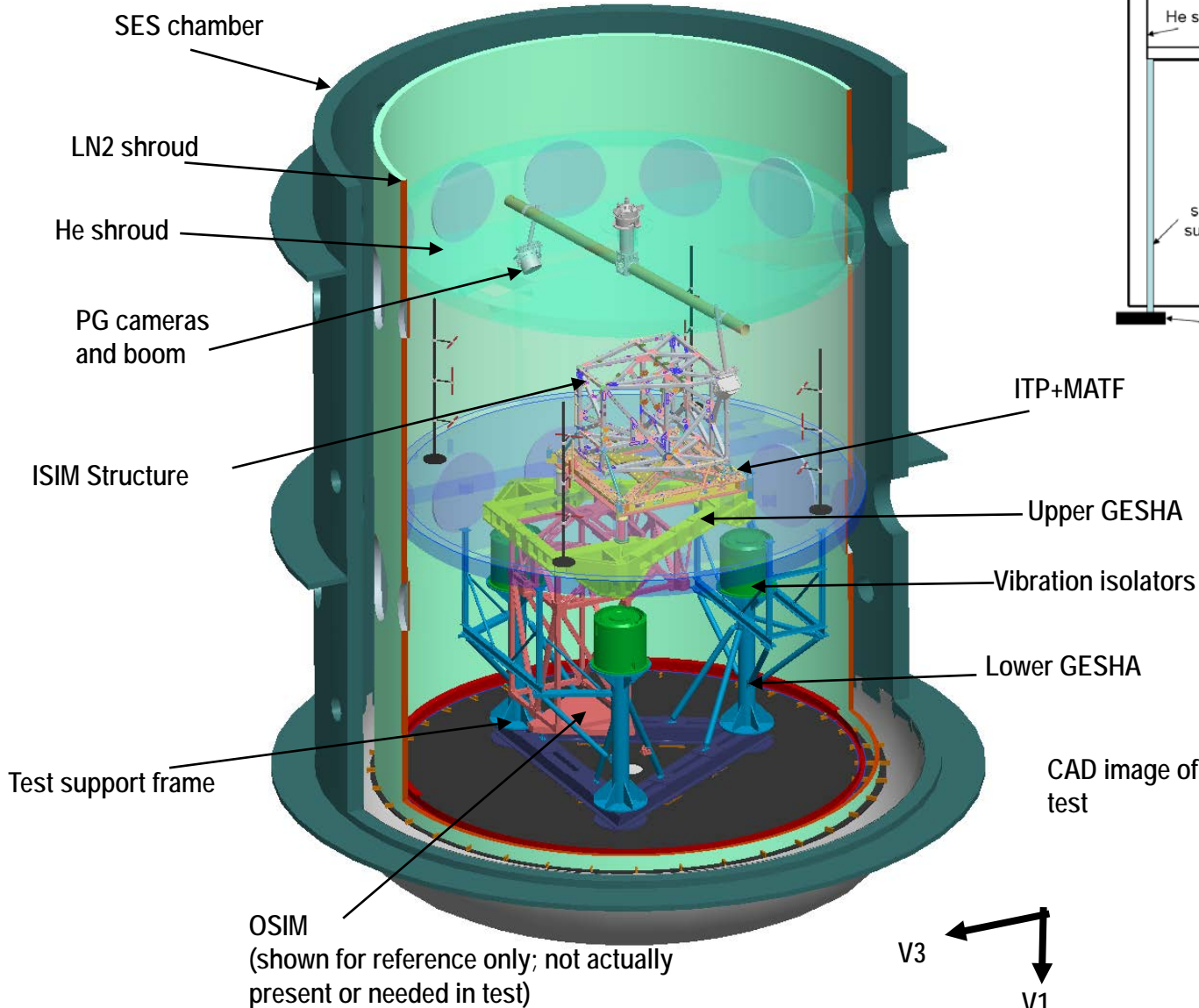

CAD image of cryo-set test



Science instruments (SIs; various scales)

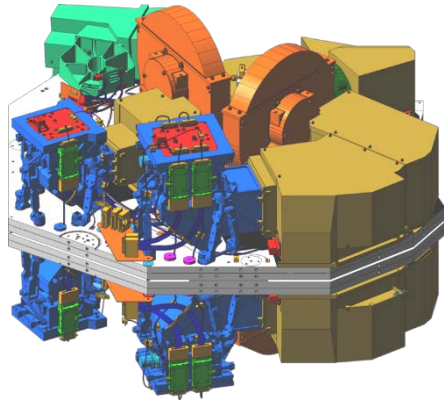

Near-Infrared Camera (NIRCam)



Near-Infrared Spectrograph (NIRSpec)

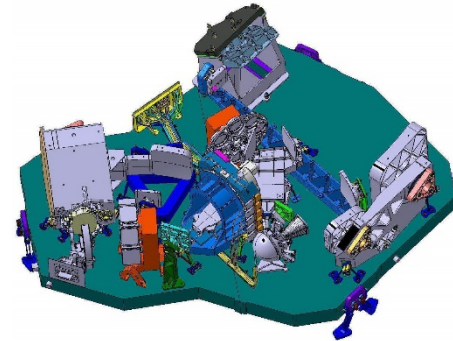
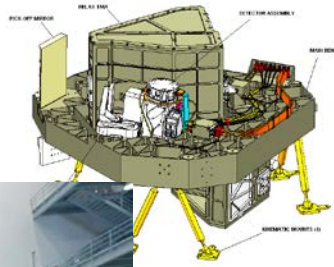

Fine Guidance Sensor (FGS)

Near-Infrared Imager and Slitless Spectrograph (NIRISS)



Mid-Infrared Instrument (MIRI)

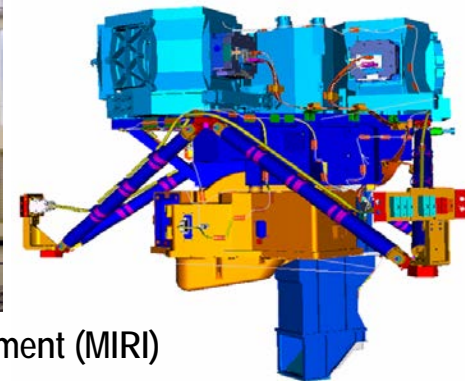



Science Instruments on alignment fixtures



NIRCam

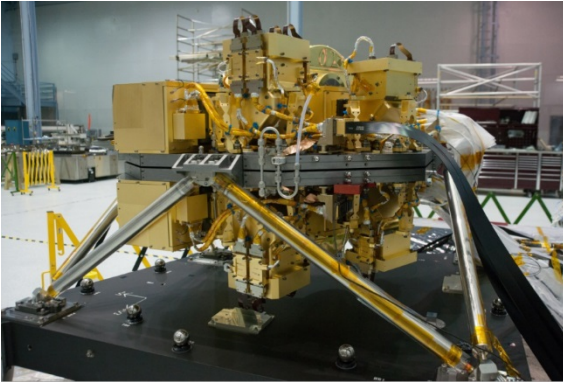

NIRSpec



FGS

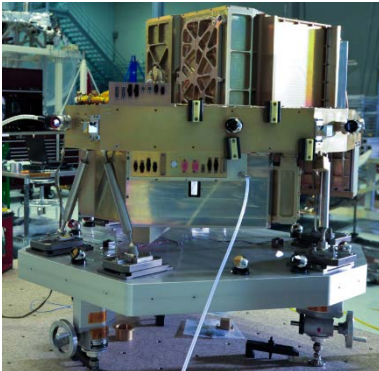

MIRI



Key Instrument Characteristics (as of Mar 06)									
Instrument	Channel/Mode	Wavelength (microns)	Typical Spectral Resolution ($\lambda/\Delta\lambda$)	FOV	Angular Resolution (arc sec)	Number of Sensor Chip Arrays	Mega Pixels	Detector Type / Format NIR=18 um pixels MIR=25 um pixels	Detector Temp (K)
NIRCam	Shortwave	0.6 - 2.3	4,10,100	2.2' x 2.2' each of 2 modules	0.032 / pixel	8	34	HgCdTe / 2048 x 2048	40
	Longwave	2.4 - 5.0	4,10,100	2.2' x 2.2' each of 2 modules	0.065 / pixel	2	8	HgCdTe / 2048 x 2048	40
NIRSpec	Multi-Object Spec	1.0 - 5.0	1000	203 x 463 mas clear shutter aperture, 267 x 528 mas pitch, 4 x 171 x 365 shutter array format, 9.7 sq arcmin multi-object targetable solid angle	see FOV	2	8	HgCdTe / 2048 x 2048	37
	Long Slits (5)	1.0 - 5.0	100, 1000, 2700	200 x 3500 mas x 3, 400 x 4000 mas, 100 x 2000 mas					
	IFU	0.7 - 5.0	2700	3 x 3 arc-sec					
MIRI	Imager	5 - 27	4-6	1.9' x 1.4'	0.11 / pixel	1	1	Si:As / 1024 x 1024	7
	Low Res Slit	5 - 11	100	5' x 0.6"	see FOV	1	1	Si:As / 1024 x 1024	7
	Med Res IFU	4.87 - 7.76	3000	3.7' x 3.7"	0.18 slice width	1	1	Si:As / 1024 x 1024	7
		7.45 - 11.87	3000	4.7' x 4.5"	0.28 slice width				
		11.47 - 18.24	3000	6.2' x 6.1"	0.39 slice width				
	17.54 - 28.82	2250	7.1' x 7.7"	0.65 slice width					
FGS-TF		1.6 - 2.5, 3.2 - 4.9	100	2.2' x 2.2'	0.065 / pixel	1	4	HgCdTe / 2048 x 2048	40
FGS-Guider		0.8 - 5.0	0.7	2.3' x 2.3' each of 2 modules	0.068 / pixel	2	8	HgCdTe / 2048 x 2048	40

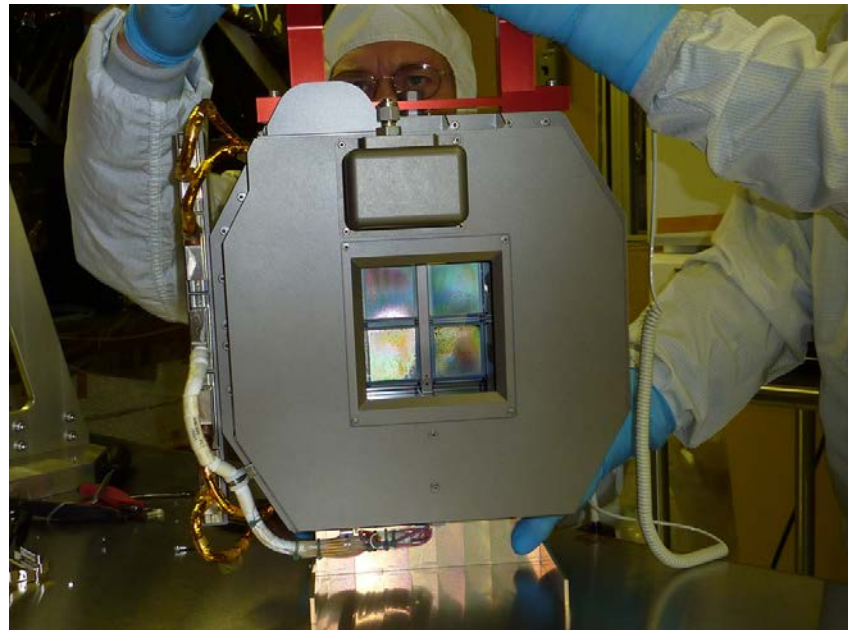
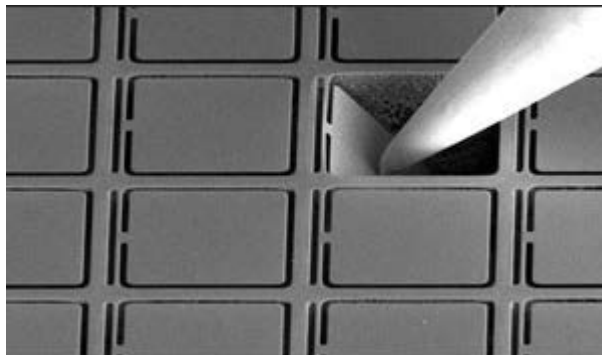
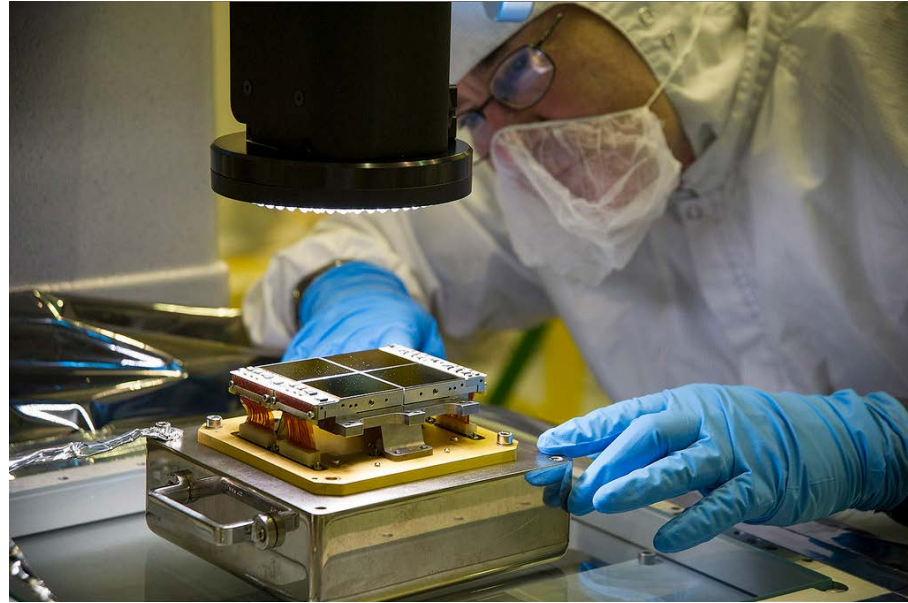
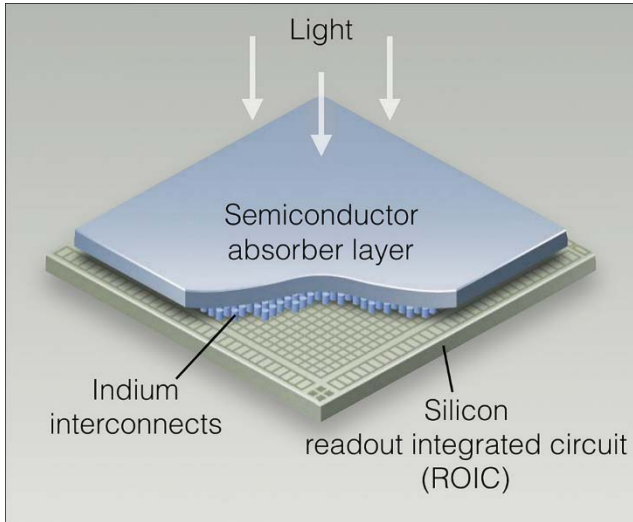

Fully integrated ISIM (SIs, Structure, etc.)

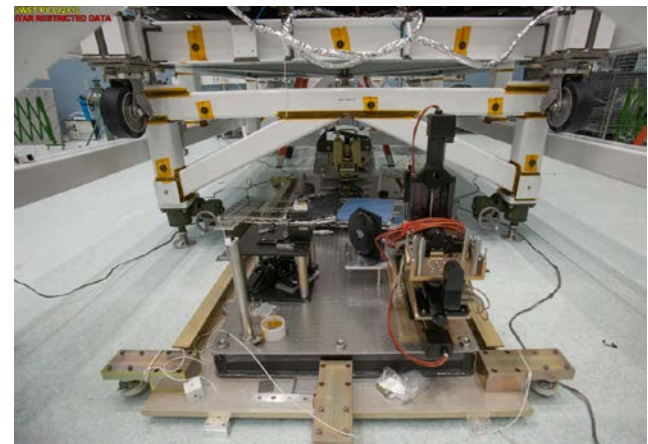
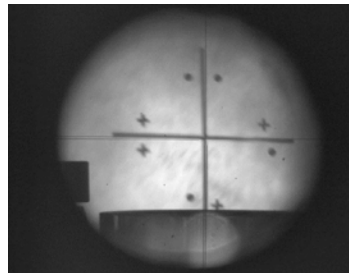
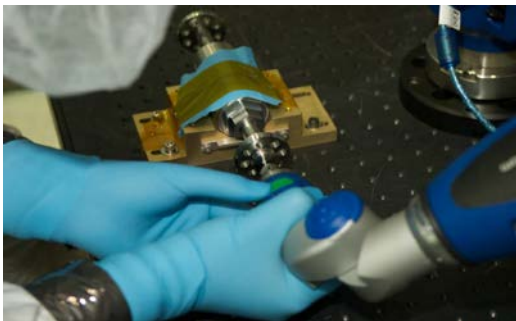
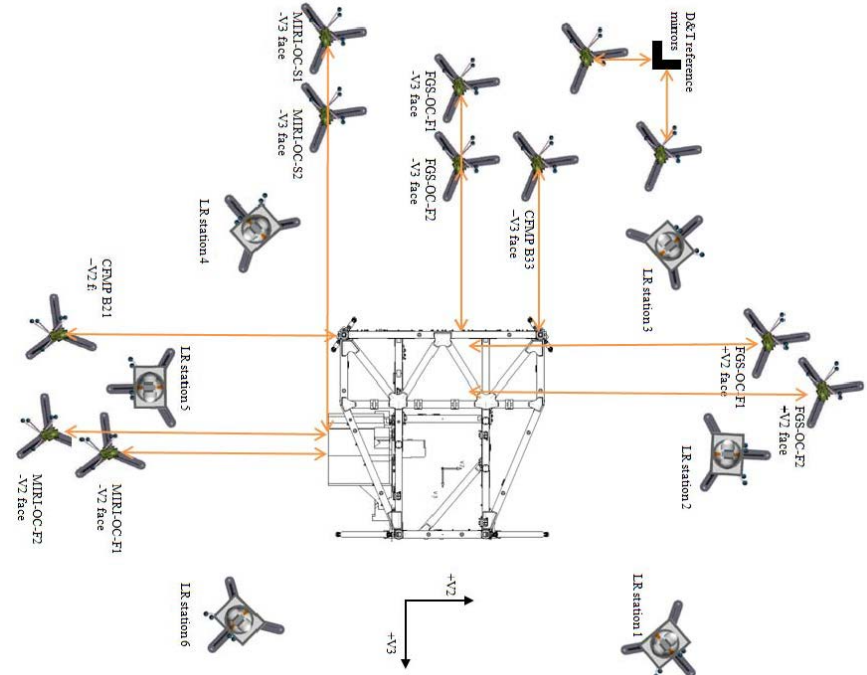
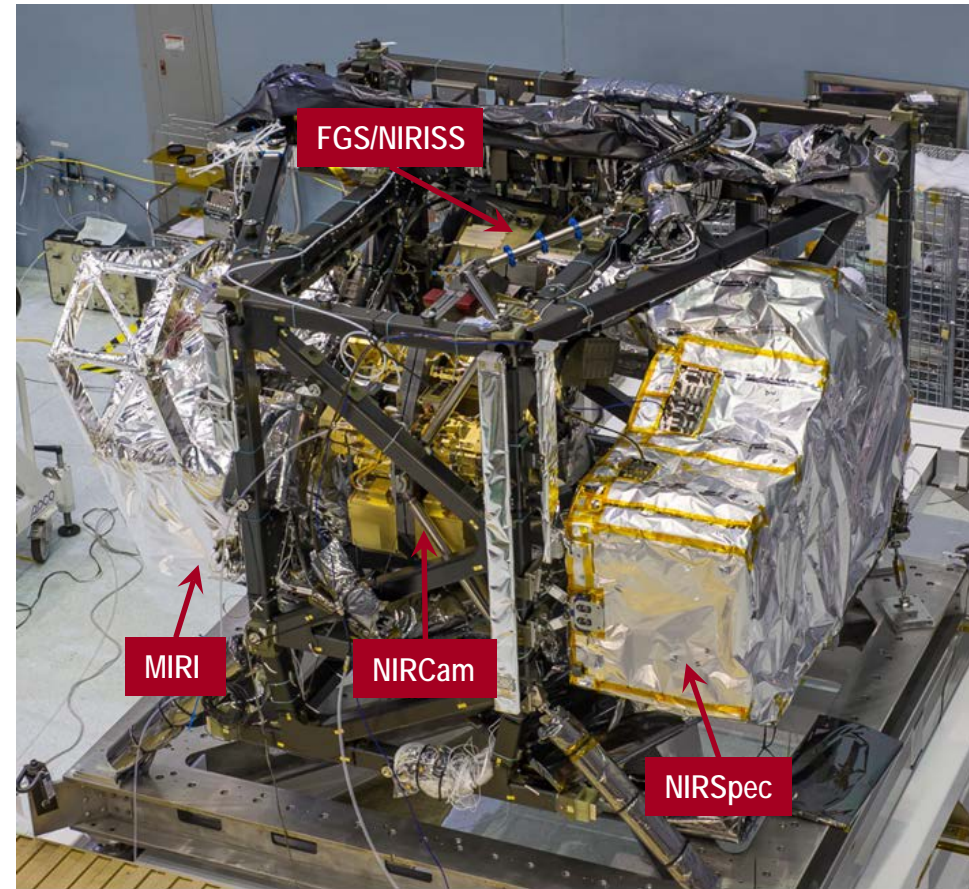



Gravity release alignment test

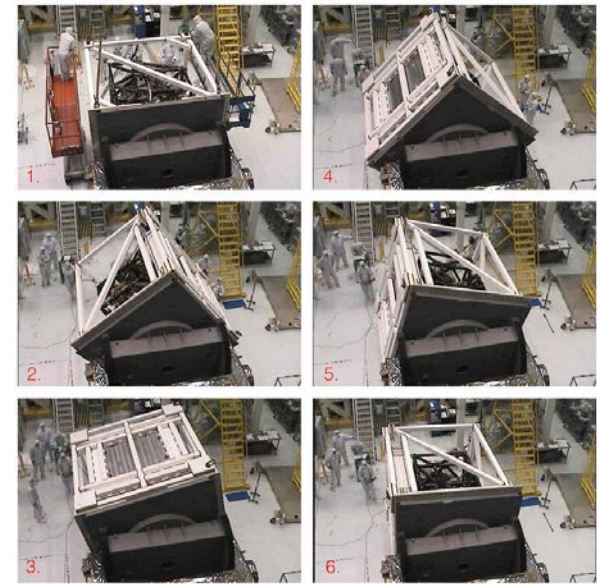



ISIM Cryo-Vacuum Test Configuration

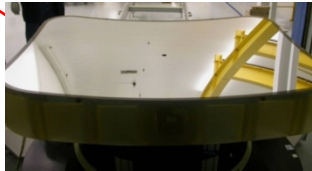
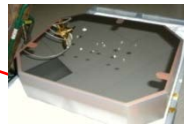
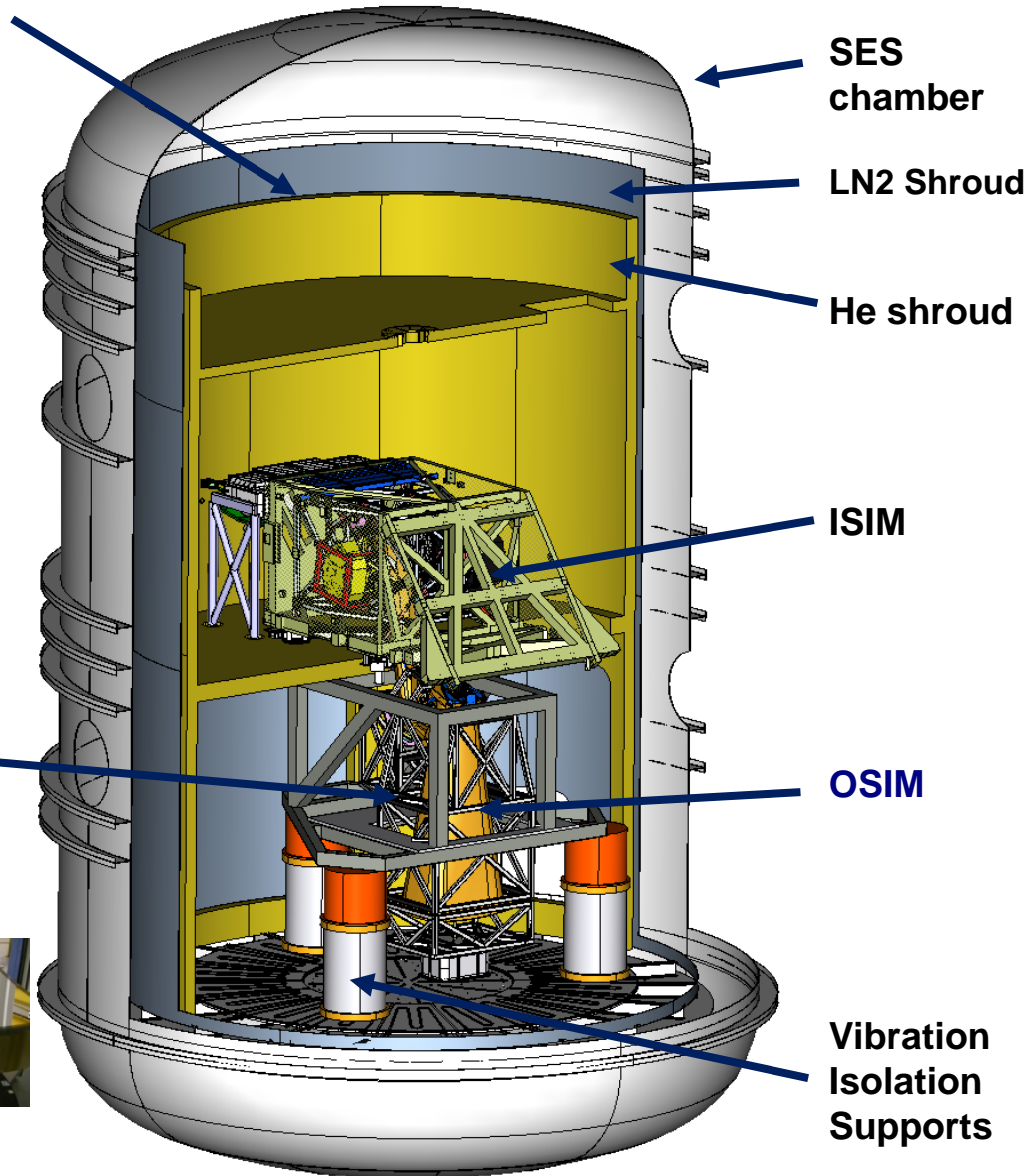
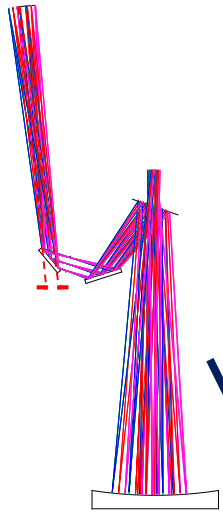

OSIM Primary Mirror



Alignment Diagnostic Module

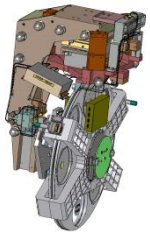

Fold Mirror 3 Tip/Tilt Gimbal Assembly





Absolute alignment of OSIM's optical output

The BATC ADM monitors the alignment of various targets located along the OSIM optical path relative to the MATF & IATF targets during cool down and during the OSIM Checkout Tests.

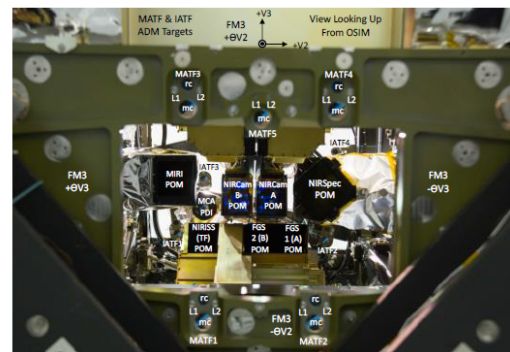
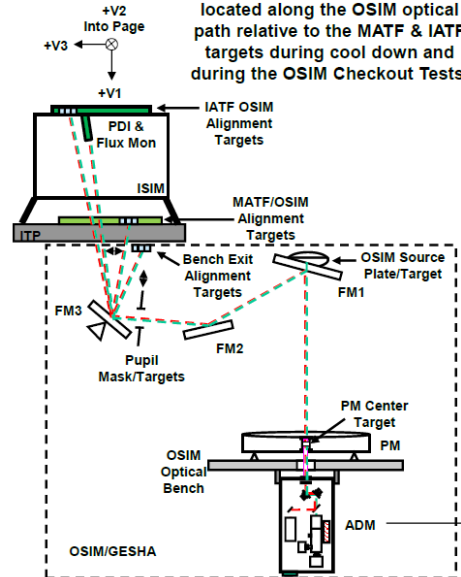
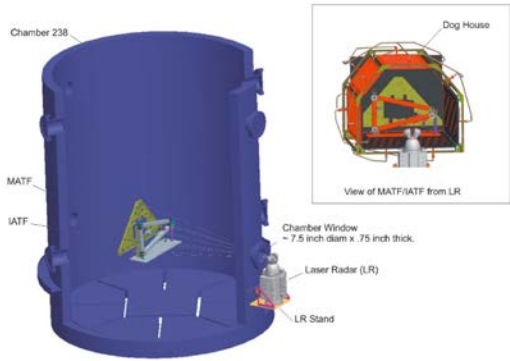

View of MATF, IATF and MCA/PDI Targets From OSIM

ADM Components Inside Pressure Vessel



OSIM cryo-vac test configuration

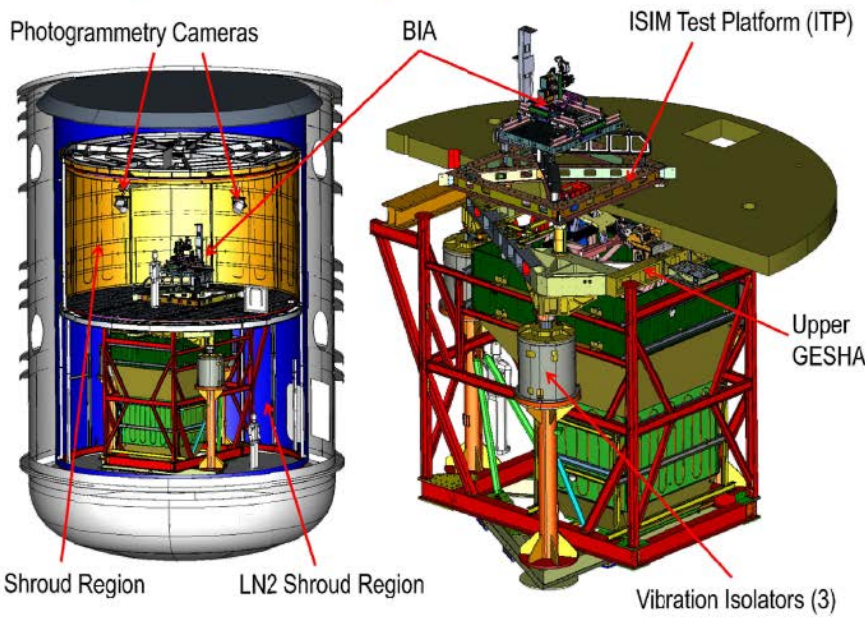



Primary mirror

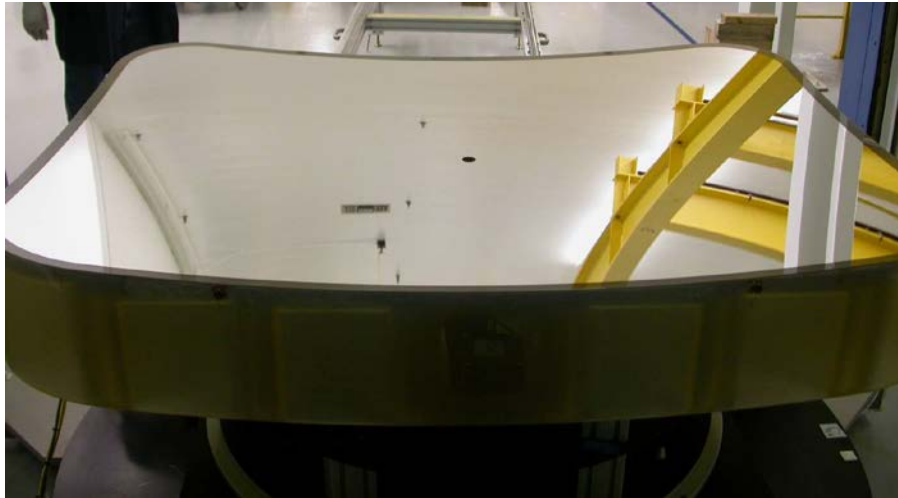

Concave mirror under test

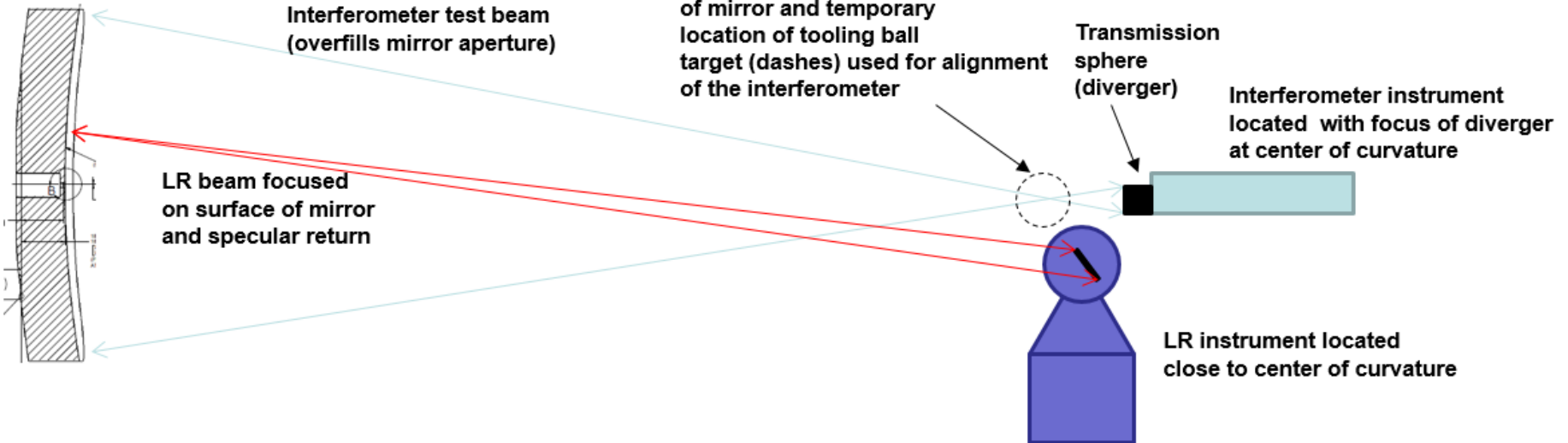



ISIM Element in SES Chamber

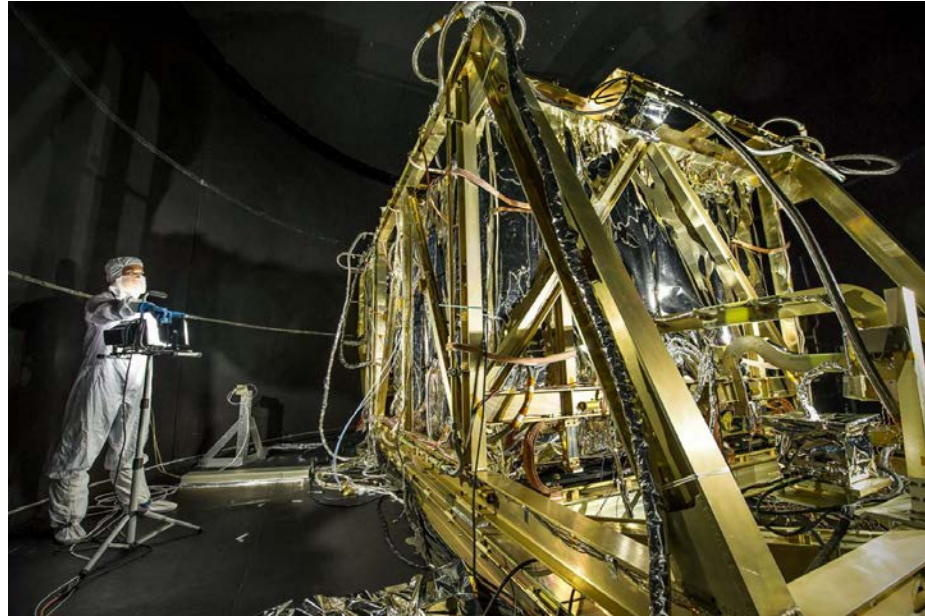

ISIM and the IEC within their test cryo-panels, all mounted on the test integration fixture

The OSIM telescope simulator, carefully closed out to keep the test environment dark out to $\sim 6\mu\text{m}$ wavelengths



Key CV3 objectives:

- Verify the ISIM System in its final configuration after environmental exposure
- Provide a post-environmental performance baseline
- Obtain critical ground calibrations needed for science data processing in flight

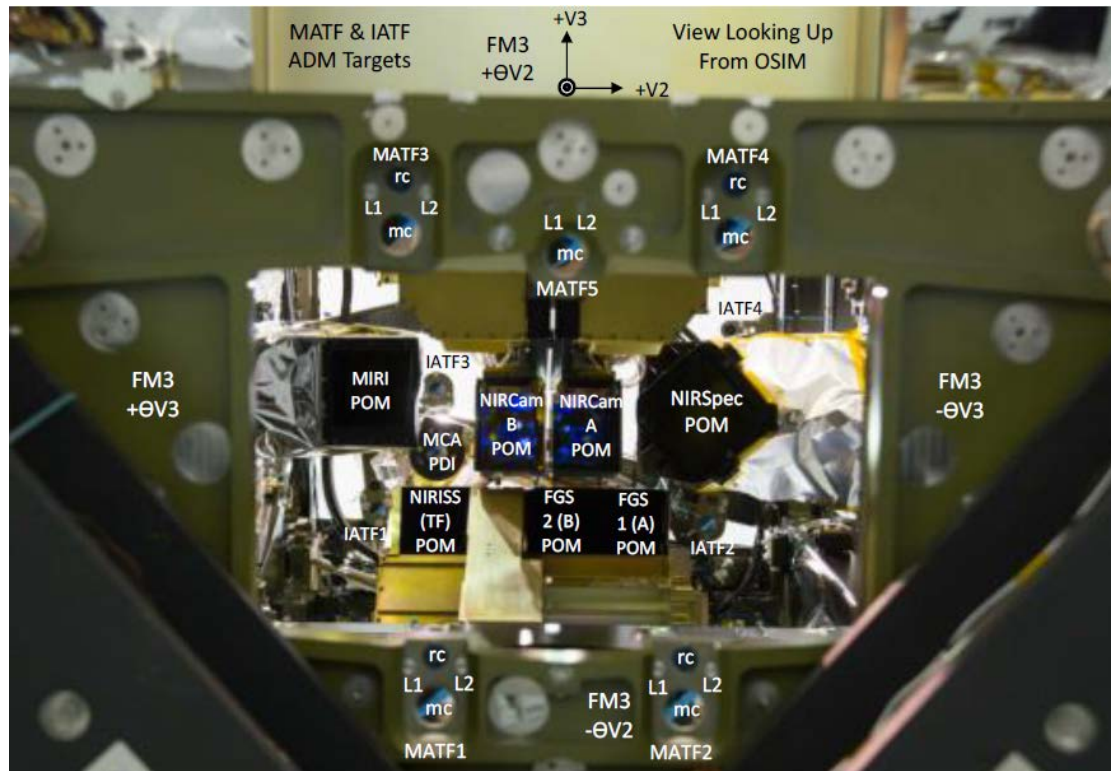



CV3 in a Nutshell: The As-Run Timeline

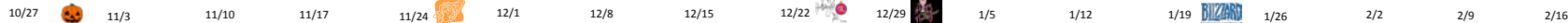

ISIM Cryo-vacuum Test #3 As Run Timeline 4/4/2016

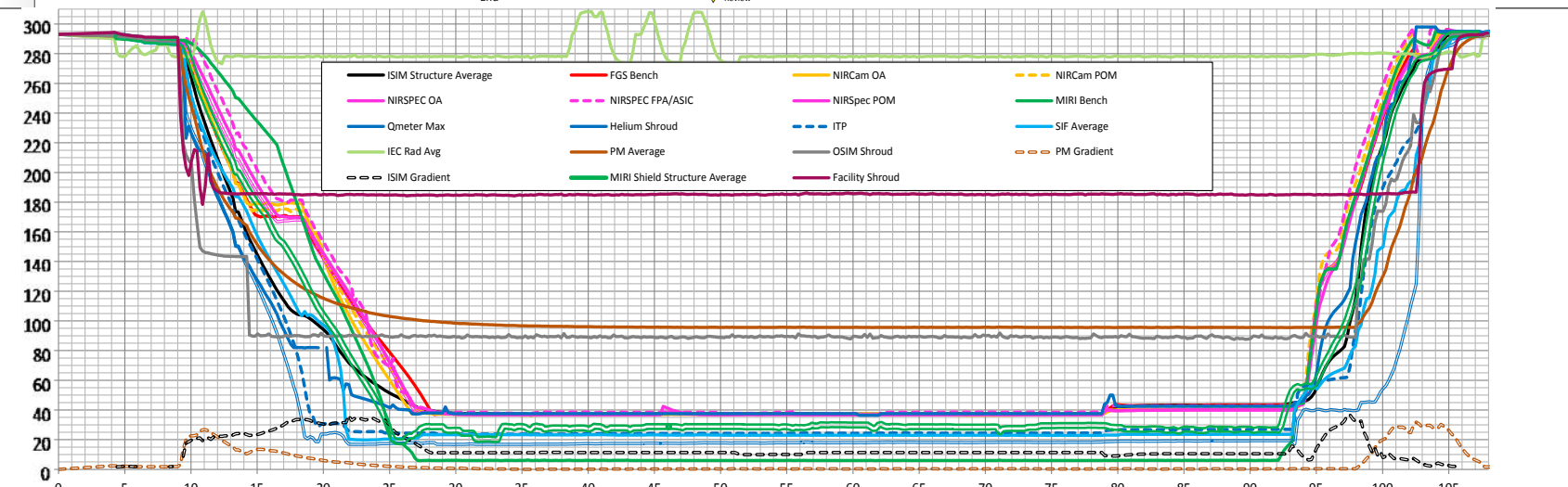
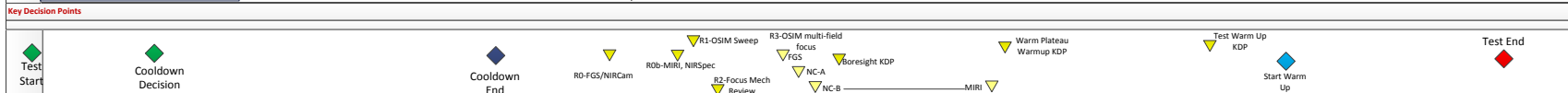
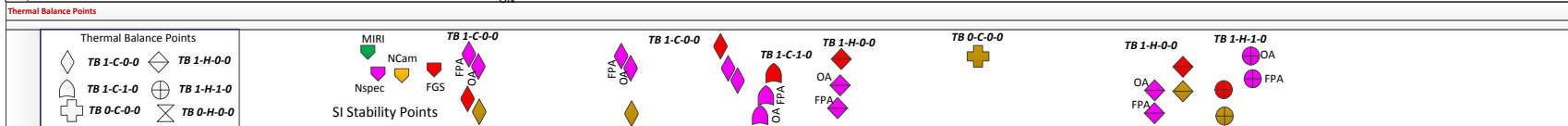
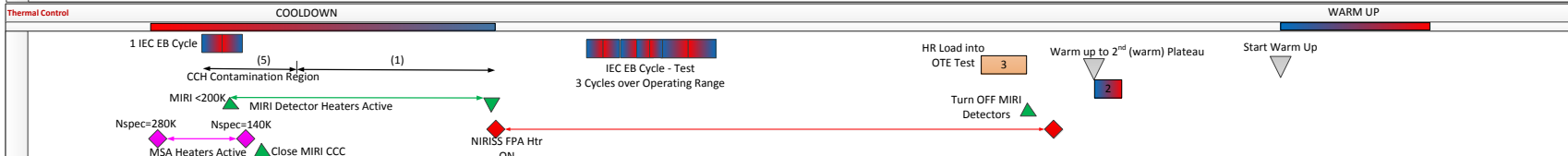
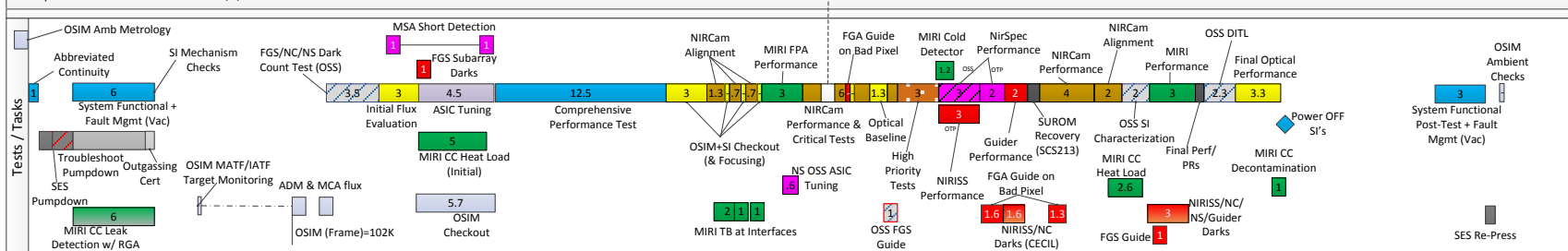



CV3 in a Nutshell: The As-Run Timeline

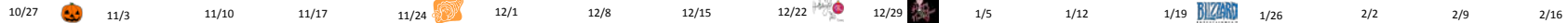

ISIM Cryo-vacuum Test #3 As Run Timeline 4/4/2016

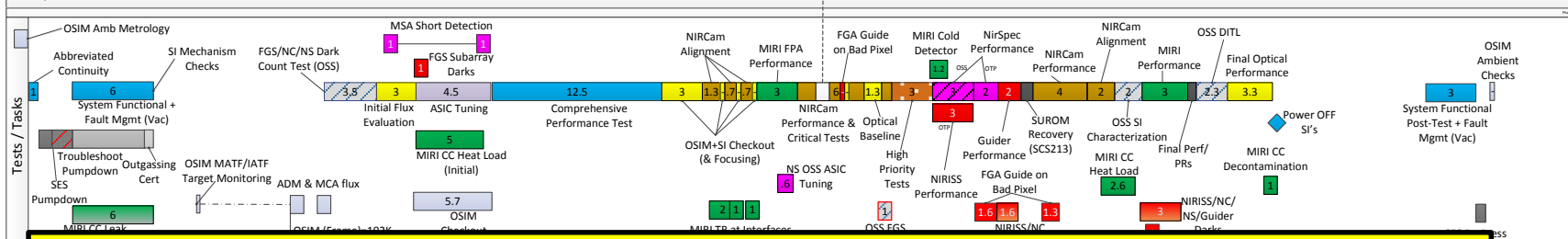

Oct 27, 2015 → Feb 12, 2016: 108 days around the clock

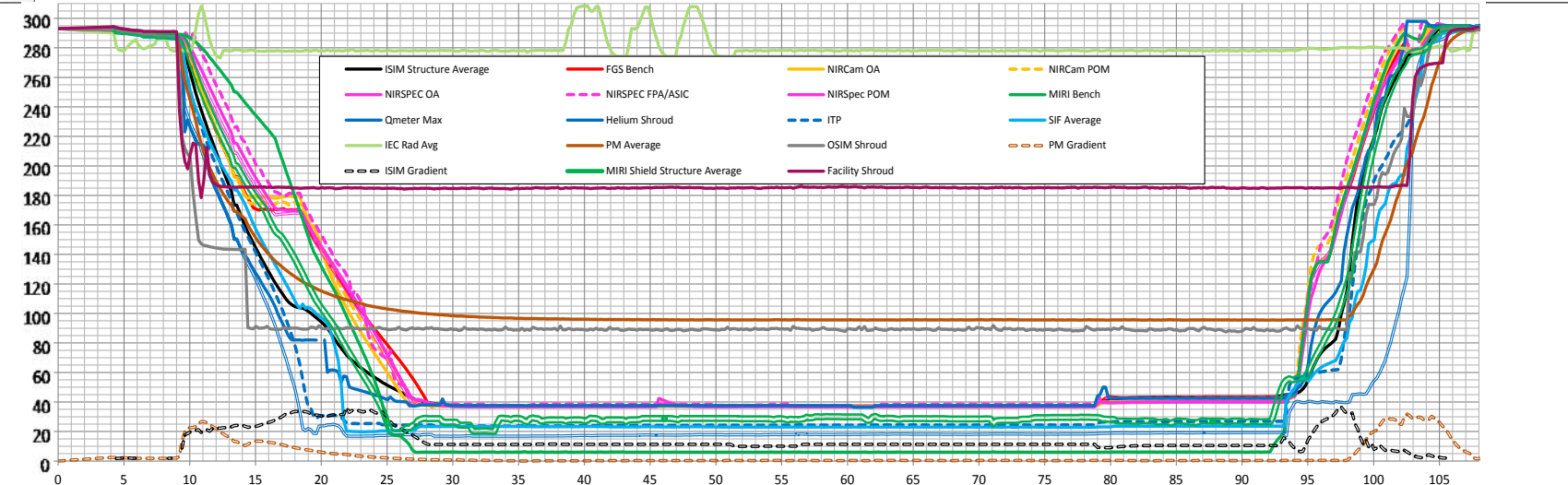
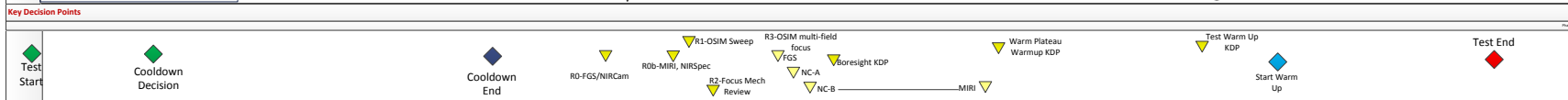
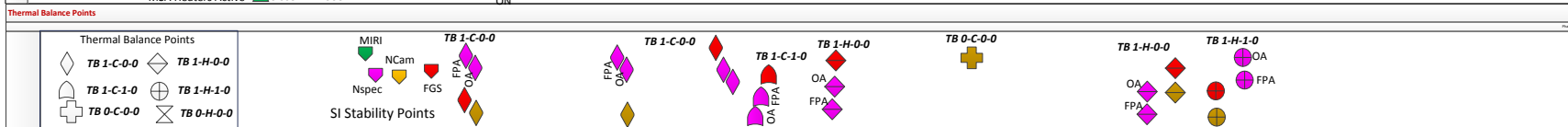



CV3 in a Nutshell: The As-Run Timeline

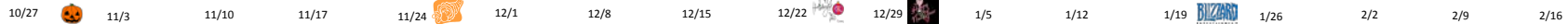

ISIM Cryo-vacuum Test #3 As Run Timeline 4/4/2016

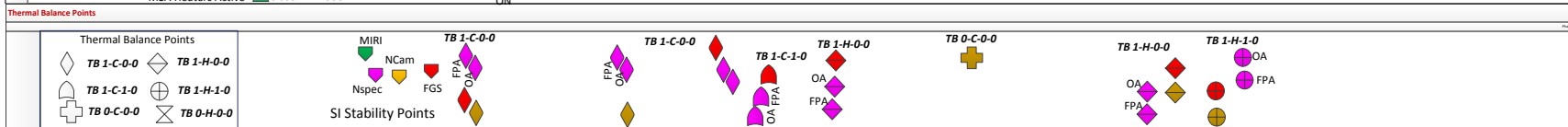
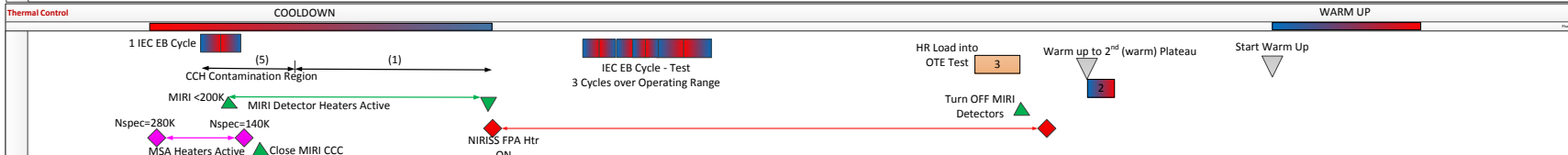
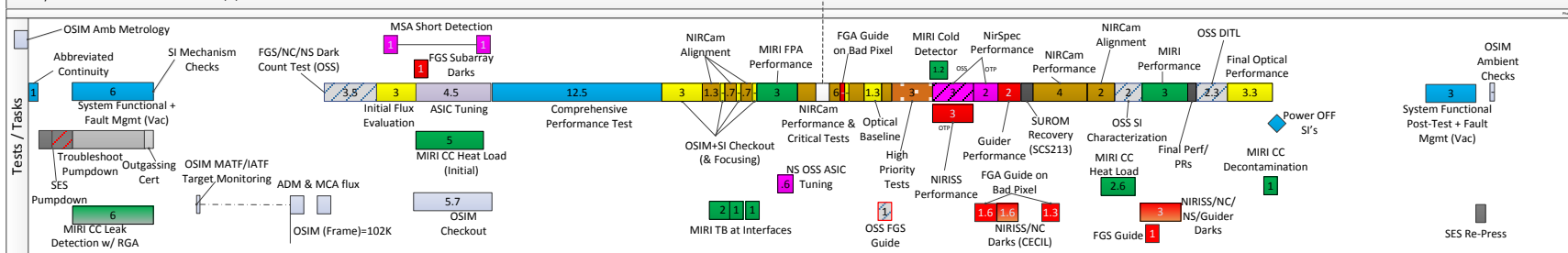

~1 Week at Ambient Vacuum: Outgassing + System Functional

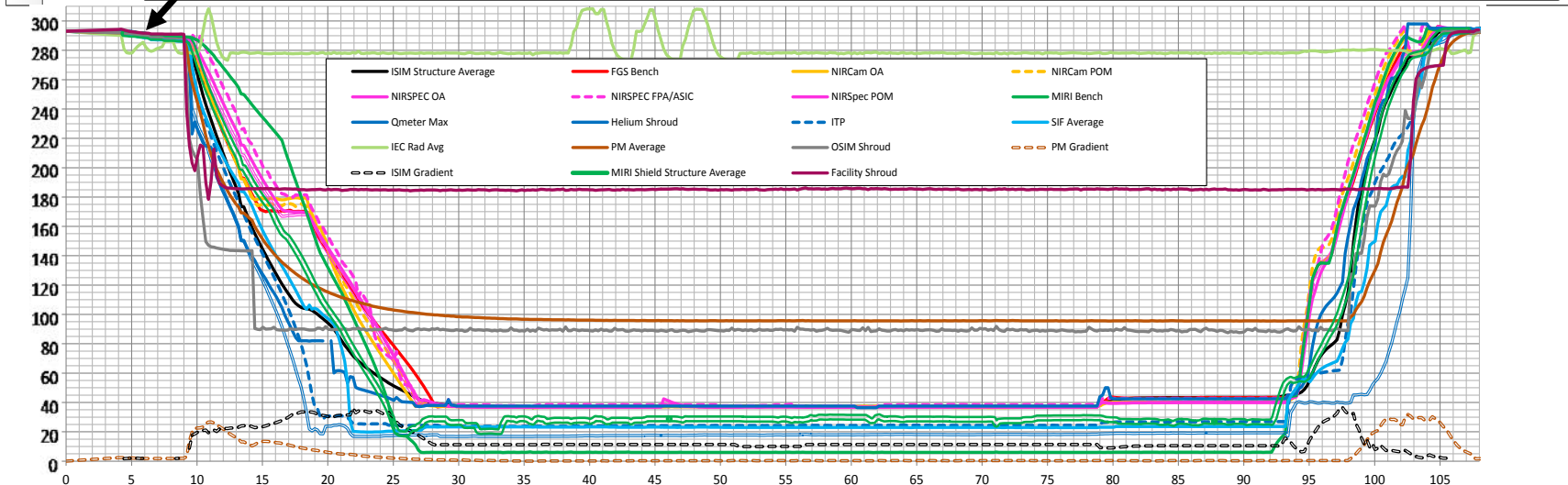



CV3 in a Nutshell: The As-Run Timeline

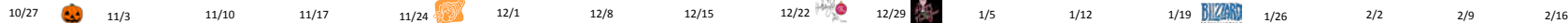

ISIM Cryo-vacuum Test #3 As Run Timeline 4/4/2016

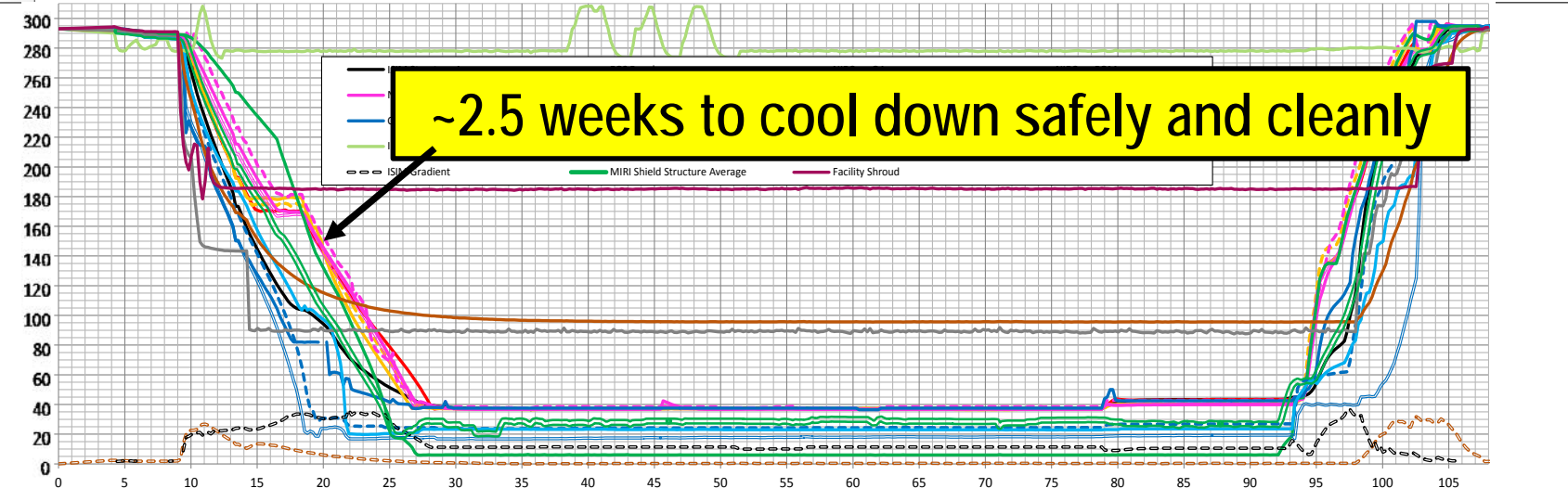
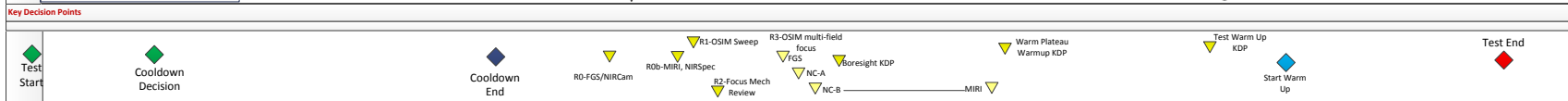
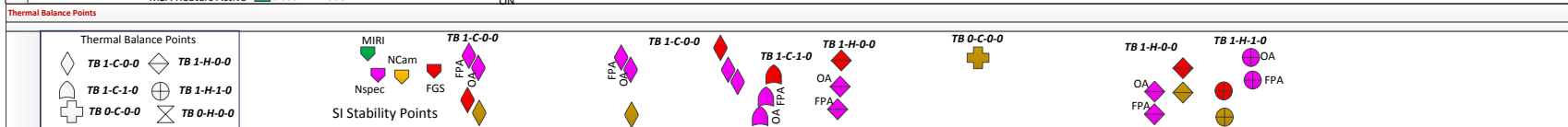
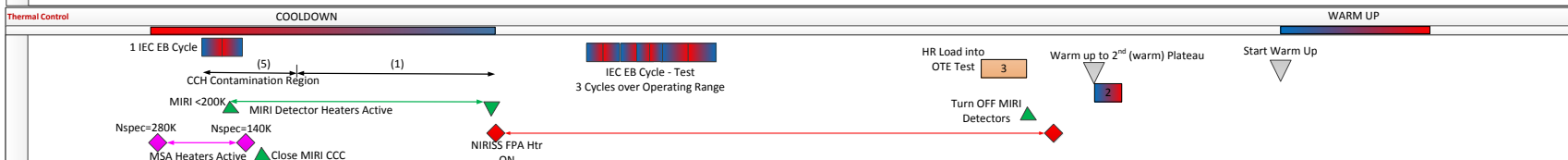
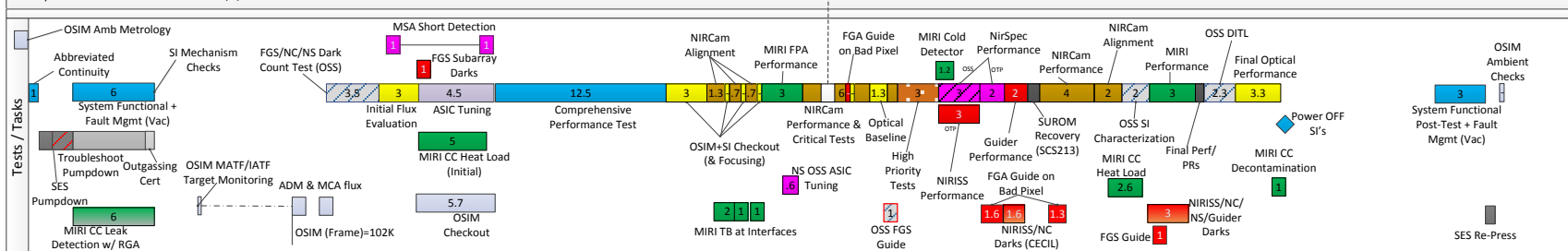



CV3 in a Nutshell: The As-Run Timeline

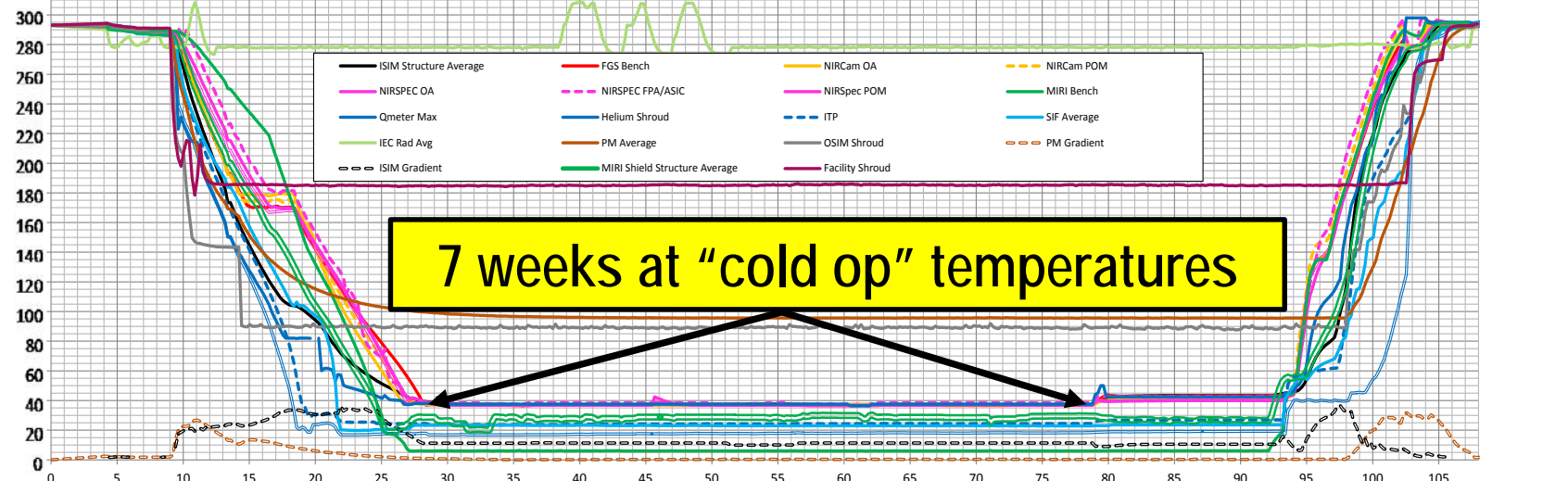
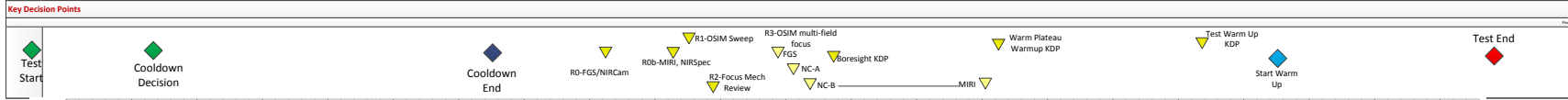
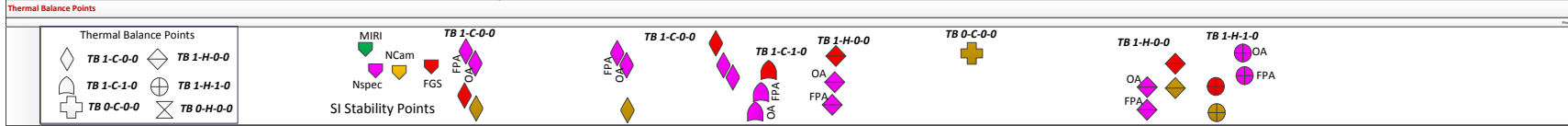
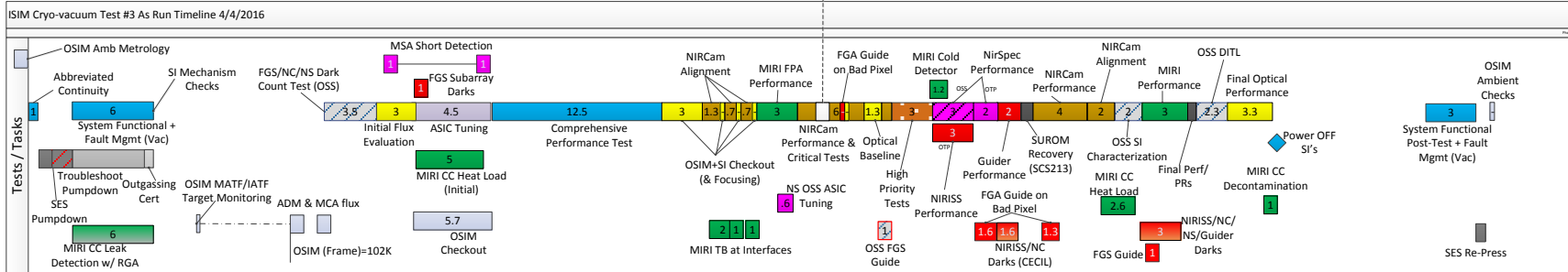
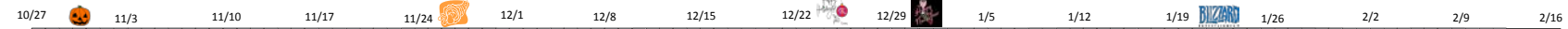



CV3 in a Nutshell: The As-Run Timeline

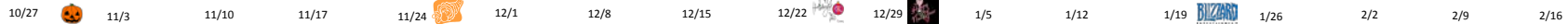

ISIM Cryo-vacuum Test #3 As Run Timeline 4/4/2016

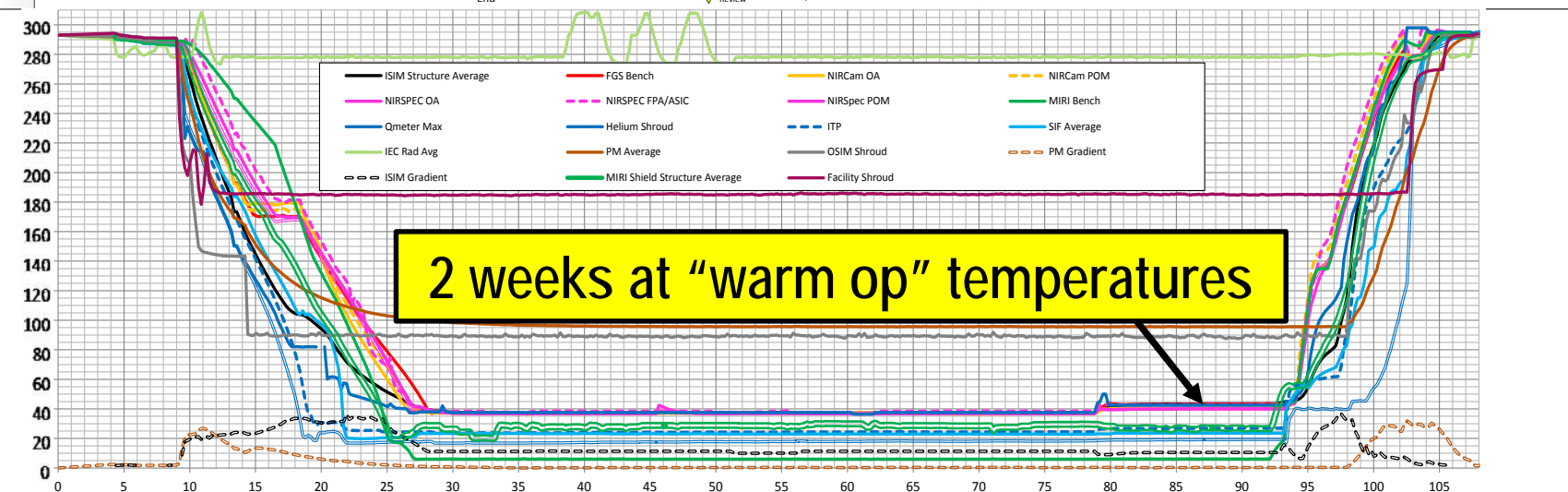
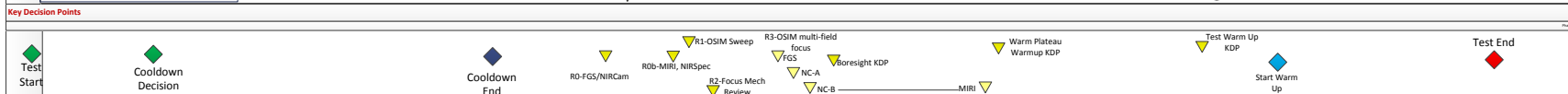
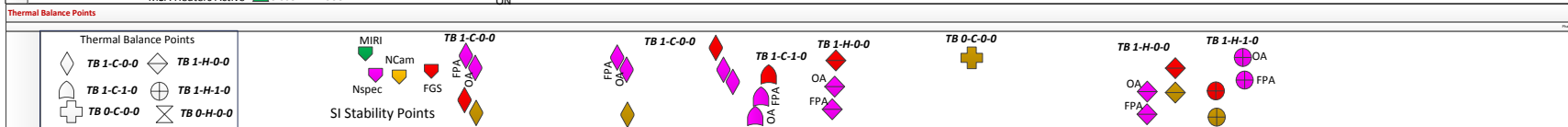
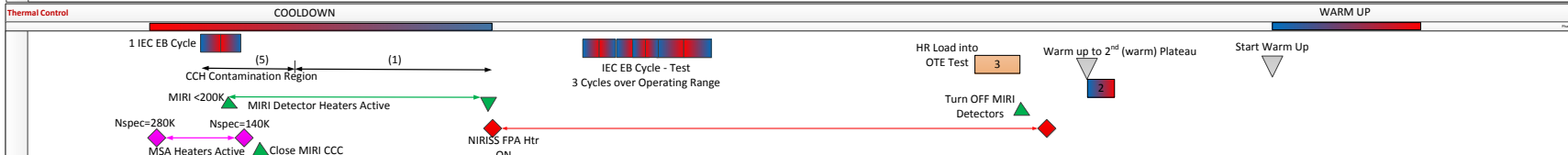
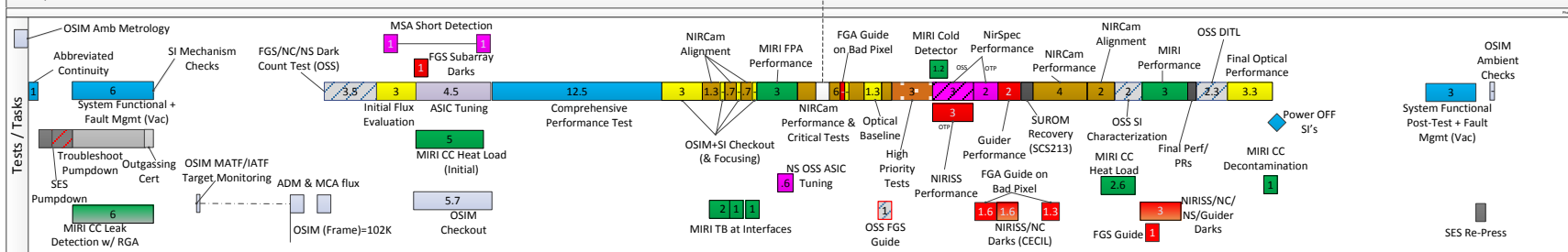



CV3 in a Nutshell: The As-Run Timeline

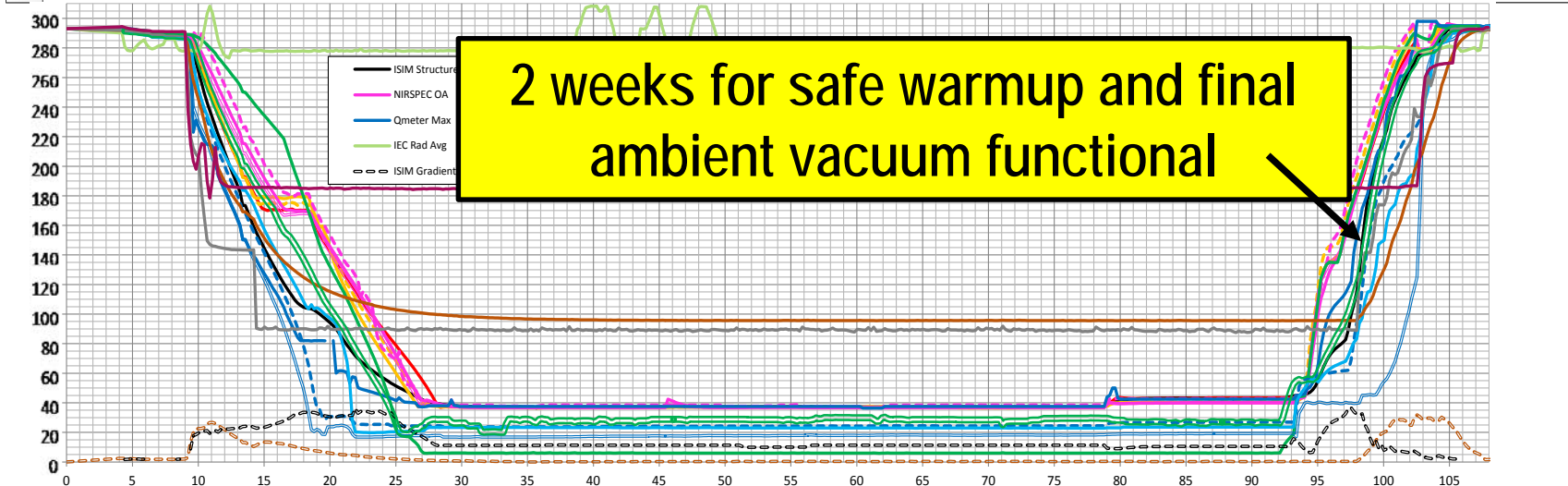
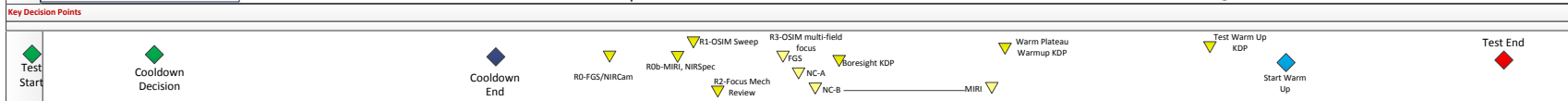
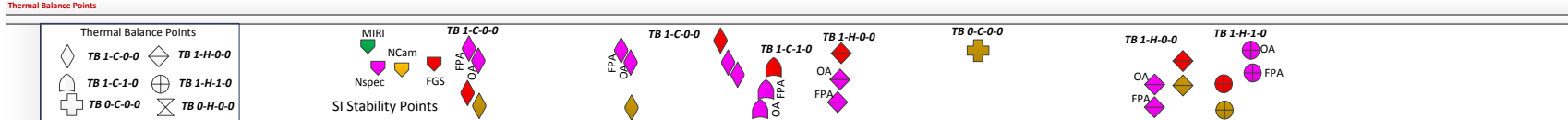
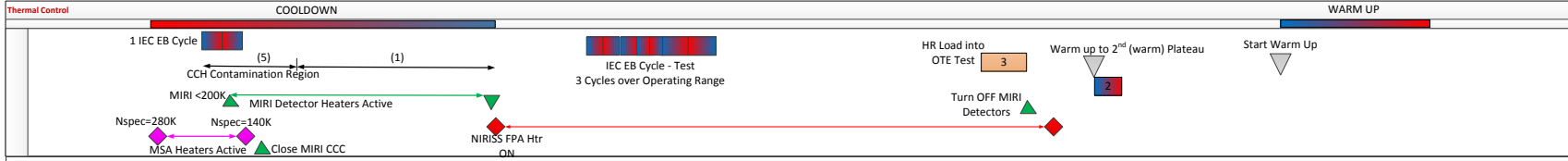
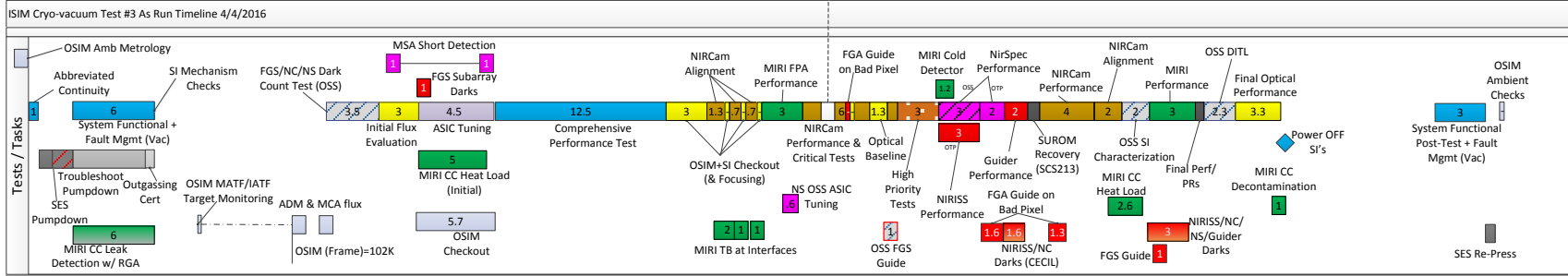
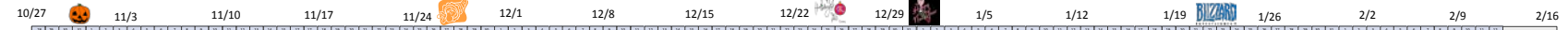



Test Went Very Well

- The test campaign ran extremely smoothly overall **and accomplished all of its significant goals**
- Thoroughly exercised ISIM instruments and systems: >25,000 images (>8 TB) collected

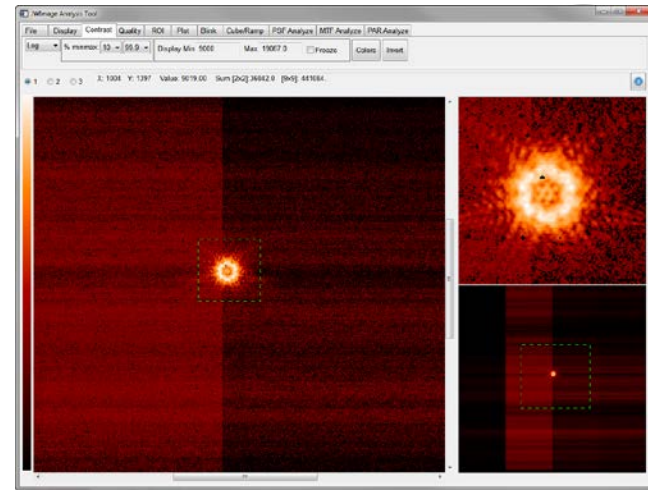

PUPIL SHEAR

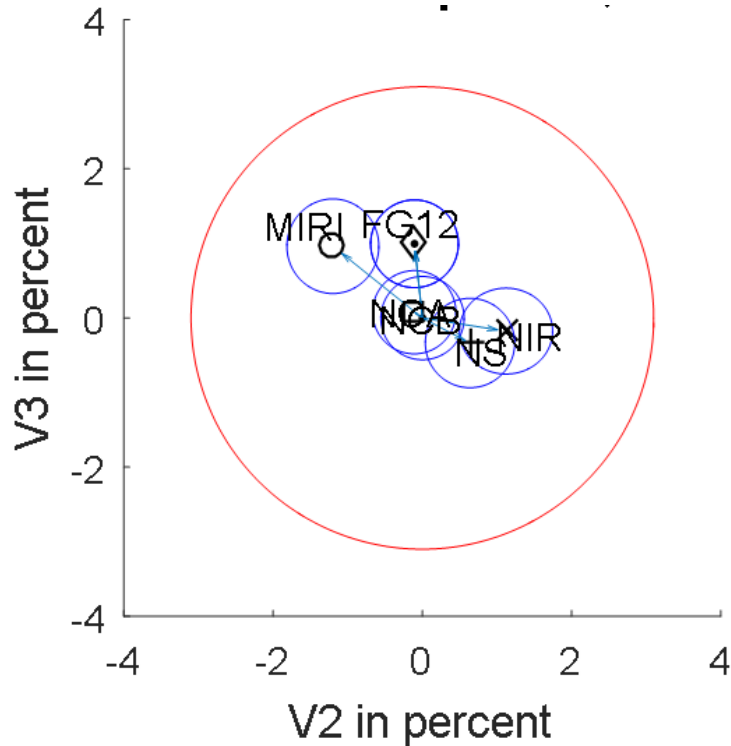

FOCUS

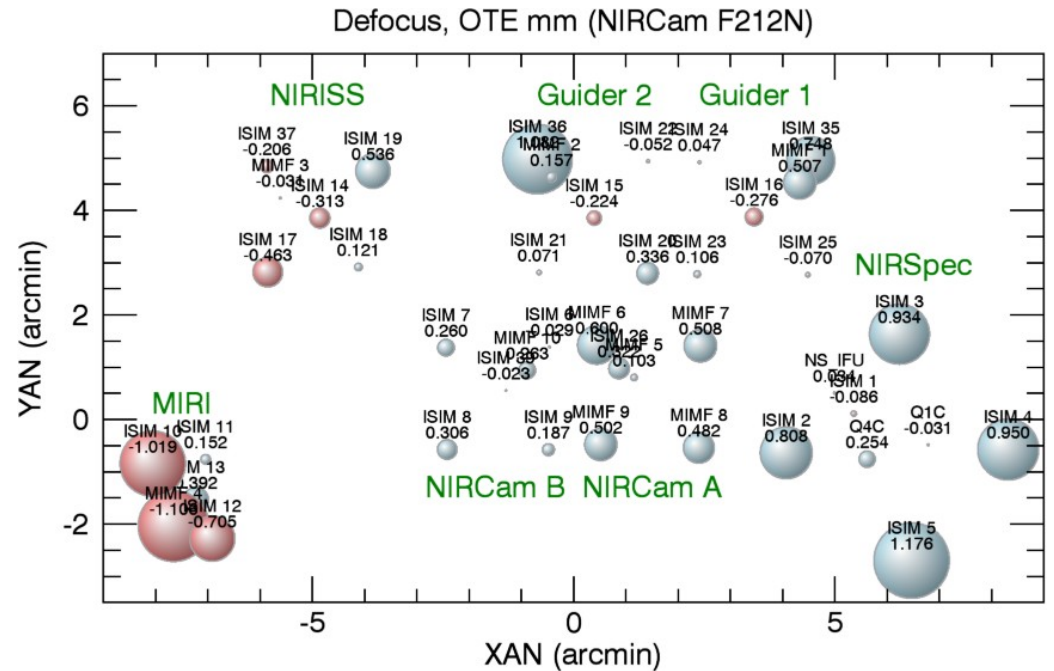

 Afterward, we attached ISIM to OTE (“OTIS”)

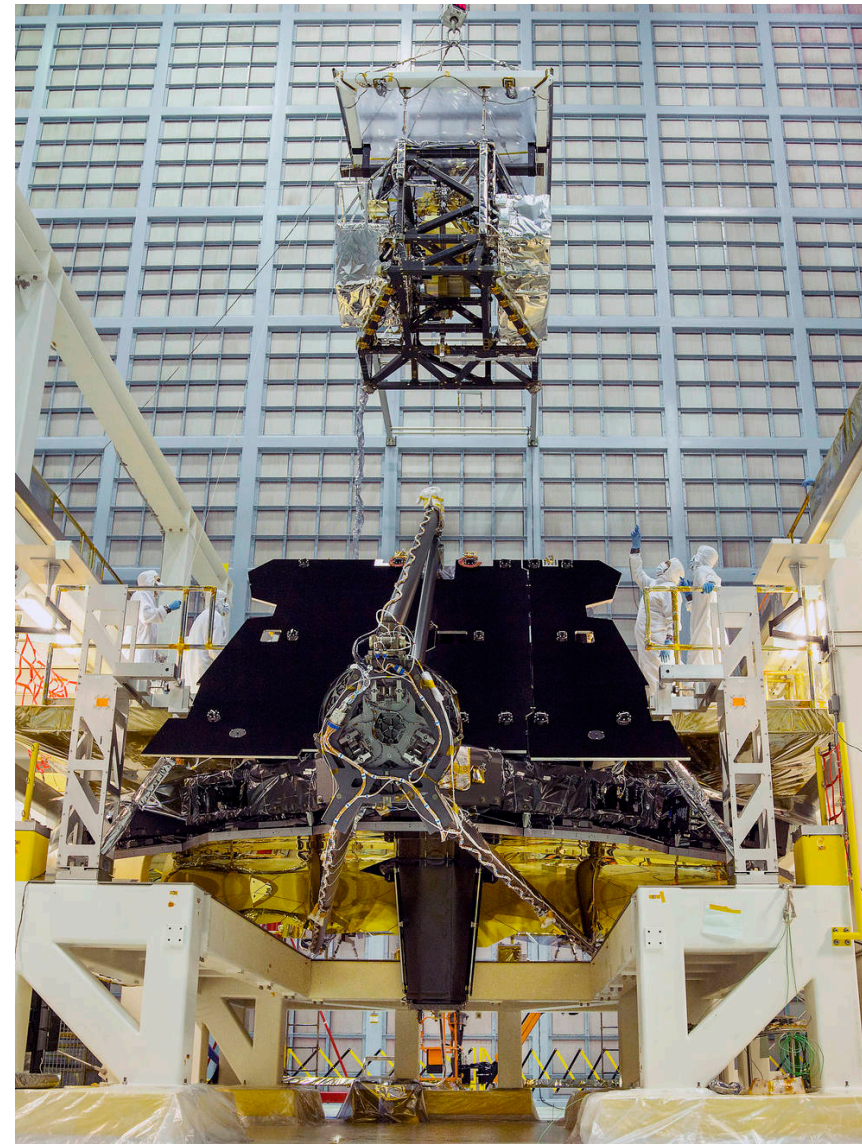



Next test: OTE+ISIM, NASA JSC, Chamber A

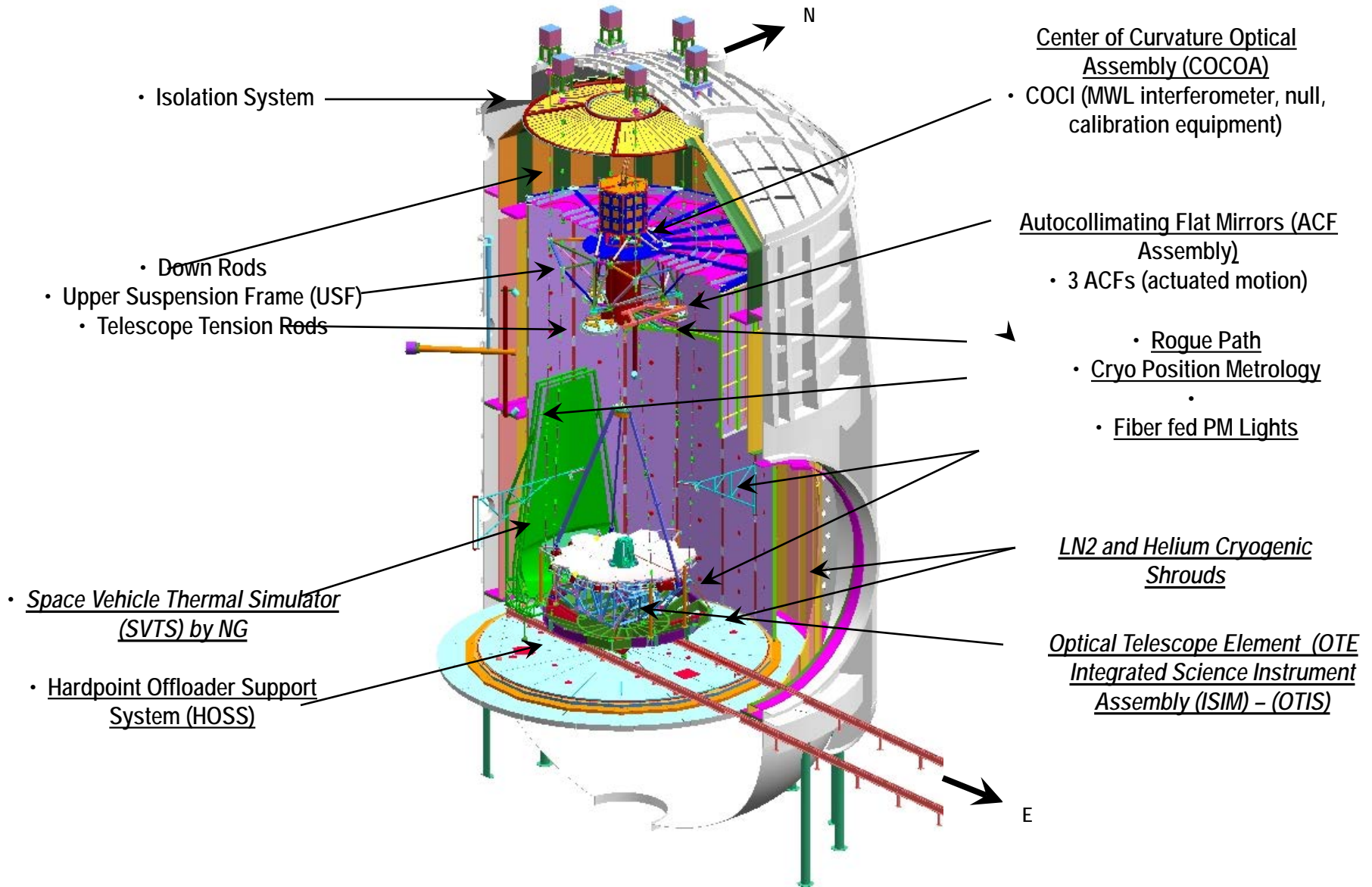

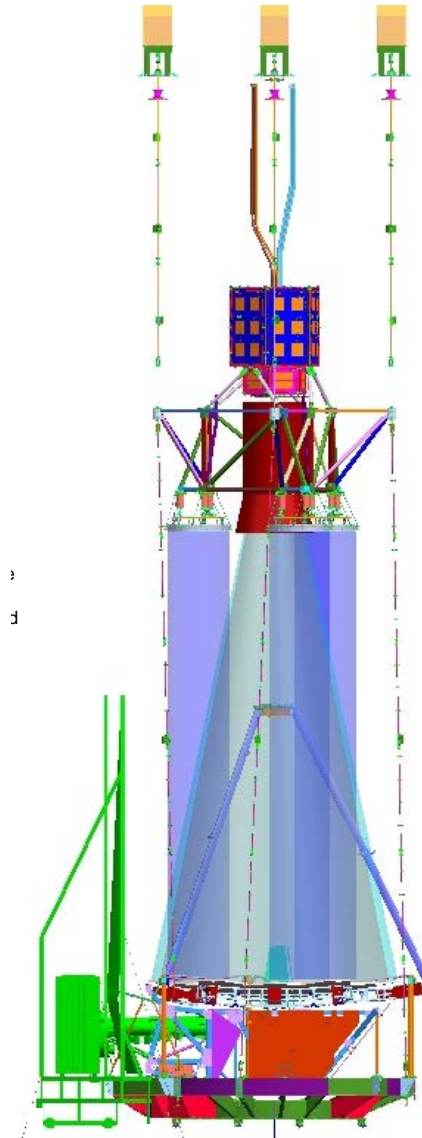
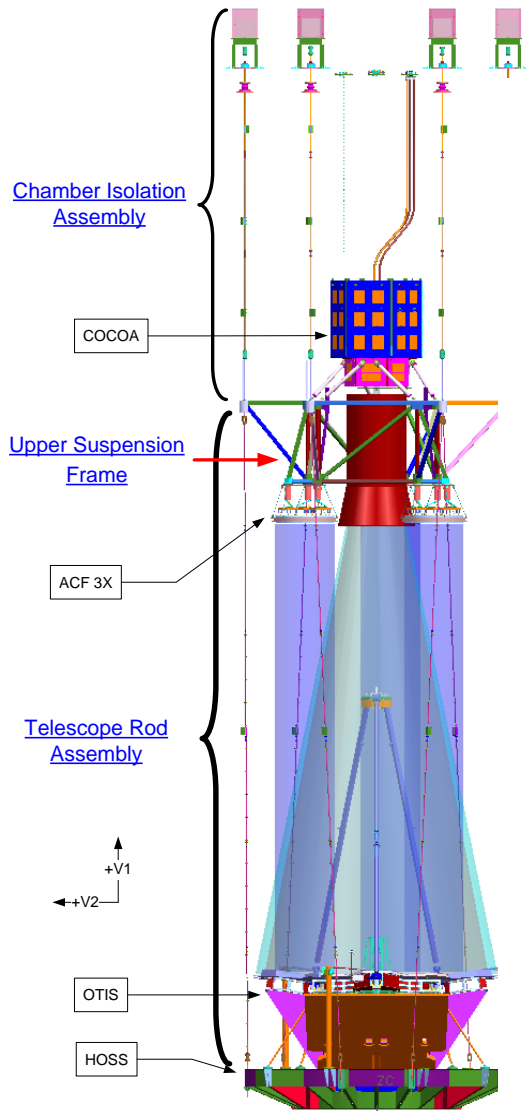

Ref. - JSC Chamber A

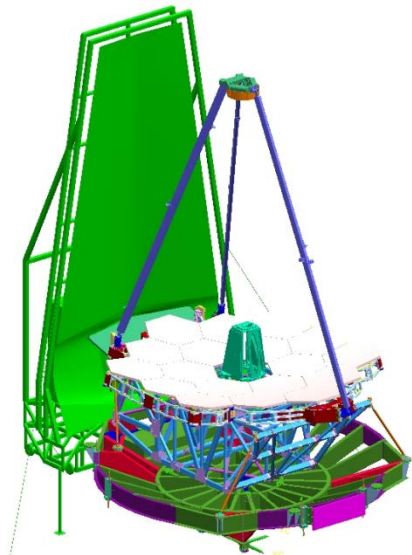

Ref. - OTIS and Thermal Sim(s).



Monitor JWST's progress and learn about its science



- www.nasa.gov
- www.jwst.nasa.gov
- <http://www.jwst.nasa.gov/science.html>

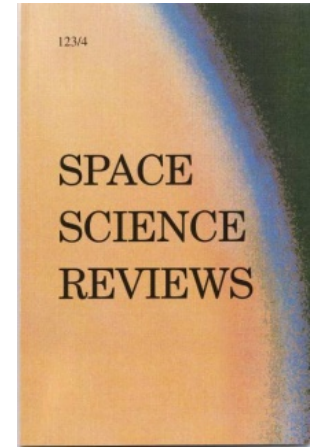
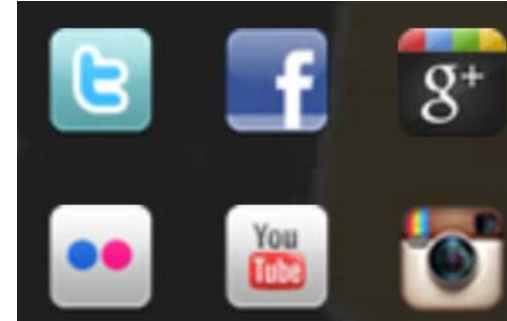

NASA needs you

- Internships: <https://intern.nasa.gov/>

(Student Opportunities; OSSI)

- Co-operative education (co-op; “Pathways”; BS--PhD)

Engineering Student Trainee - NASA Pathways Intern

Vacancy Announcement Number: GS16I0015

Pay Plan, Series, and Grade: GS- GS-0899-4/5/6/7/9/11

Code: 220, 360, 550, 560, 580, 590

Duty Station: Greenbelt, MD

Closing Date: 10/03/2016

Engineering Student Trainee - NASA Pathways Intern

Vacancy Announcement Number: GS16I0016

Pay Plan, Series, and Grade: GS- GS-0899-4/5/6/7/9/11

Code: 250, 580, 590

Duty Station: Wallops Island, VA

Closing Date: 10/03/2016

- Civil servant jobs

Research Astrophysicist, AST, Atmospheres and Ionospheres

Vacancy Announcement Number: GS16D0080

Pay Plan, Series, and Grade: GS-1330-13

Code: 693

Duty Station: Greenbelt, MD

Closing Date: 09/29/2016

Research Space Scientist, AST, Planetary Studies

Vacancy Announcement Number: GS16D0084

Pay Plan, Series, and Grade: GS-1330-12

Code: 691

Duty Station: Greenbelt, MD

Closing Date: 09/29/2016

- “Contractor” jobs (industry, academia)





Questions?

