

The Geostationary Operational Satellite R Series SpaceWire Based Data System

Session: SpaceWire Networks and Protocols, Long Paper

William Anderson
GOES-R Flight Data System Lead Engineer
NASA Goddard Space Flight Center
Greenbelt, MD USA
william.h.anderson@nasa.gov

Michael Birmingham
GOES-R Embedded Software Engineer
NASA Goddard Space Flight Center
Denver, CO USA
mike.j.birmingham@lmco.com

Alexander Krimchansky
GOES-R Mission Systems Manager
NASA Goddard Space Flight Center
Greenbelt, MD USA
alexander.krimchansky@nasa.gov

Matthew Lombardi
GOES-R Simulation and Test Engineer
Lockheed Martin
Denver, CO USA
matthew.s.lombardi@lmco.com

Abstract - The Geostationary Operational Environmental Satellite R-Series Program (GOES-R, S, T, and U) mission is a joint program between National Oceanic & Atmospheric Administration (NOAA) and National Aeronautics & Space Administration (NASA) Goddard Space Flight Center (GSFC). SpaceWire was selected as the science data bus as well as command and telemetry for the GOES instruments. GOES-R, S, T, and U spacecraft have a mission data loss requirement for all data transfers between the instruments and spacecraft requiring error detection and correction at the packet level. The GOES-R Reliable Data Delivery Protocol (GRDDP) [1] was developed in house to provide a means of reliably delivering data among various on board sources and sinks. The GRDDP was presented to and accepted by the European Cooperation for Space Standardization (ECSS) and is part of the ECSS Protocol Identification Standard [2].

GOES-R development and integration is complete and the observatory is scheduled for launch November 2016. Now that instrument to spacecraft integration is complete, GOES-R Project reviewed lessons learned to determine how the GRDDP could be revised to improve the integration process. Based on knowledge gained during the instrument to spacecraft integration process the following is presented to help potential GRDDP users improve their system designs and implementation.

I. INTRODUCTION

The GOES-R, S, T, and spacecraft program is a key element of the National Oceanic and Atmospheric Administration's (NOAA) weather satellite observation operations. The GOES-R spacecraft uses European Cooperation for Space Standardization (ECSS) SpaceWire (SpW) [3] for the transfer of sensor, telemetry, ancillary, command, time code, and time synchronization information between instruments and the spacecraft. In addition, the spacecraft and instruments are required to use the GRDDP for all data transferred over on-board SpaceWire links.

In an effort to minimize risk the GRDDP underwent a robust testing program by the GOES-R Project, instrument providers, and spacecraft developer. Several SpaceWire router implementations were used in this testing as well final mission integration. These implementations included two different ASICs and three different FPGAs designs. Integrating this diverse combination of SpW routers proved to be a challenge for GOES-R. The current version of GRDDP will not be modified for the follow-on GOES spacecraft. Hardware and software for the GOES-S,T, and U spacecraft are copies of GOES-R. The construction and integration of these spacecraft have progressed to the point where it is cost prohibitive to make changes to their hardware and software.

II. CURRENT GRDDP FEATURES

The GRDDP uses the lower level SpaceWire data link layer to provide reliable packet delivery services to one or higher level host application processes. For the GOES-R series spacecraft, the lower level protocol is the Packet Level service specified in the ECSS SpaceWire standard [3]. The original GRDDP requirement goal was to have no data loss with a simple to implement protocol using microcontroller, ASIC, or FPGA designs.

The GRDDP design philosophy is that all good received packets must send an acknowledgement packet (ACK) to the transmitter. Packets with errors are discarded and not acknowledged. The header is eight bytes and has an eight bit CRC trailer. The protocol can be used in simple point-to-point full duplex interfaces or a full networked environment. GOES-R has both point-to-point and networked environments.

The GRDDP has two protocol services which are Reliable Delivery (RD) and Urgent Message (UM). The RD service requires a positive acknowledgement for all received error free packets. This service is used for data that is critical to the mission. Examples of RD data types are instrument sensor data, commands, and critical telemetry. UM service is for data that is fire-and-forget such as ancillary data and less critical telemetry that updates at higher rates. RD packets must utilize the header sequence number for sliding window, missing packet detection, duplicate packet detection, and packet order processing where UM packets do not.

There is a virtual channel capability included in the GRDDP. This allows up to 96 virtual channels (VC) to be used on a single physical SpW link. VCs are defined by SpW Logical Address (SLA) pairs that are required to operate independently. The VC capability allows mixing of low, medium, and high rate data on a single physical SpW connection, while having a logical separation.

Packet segmentation is not allowed in order to comply with the keep-it-simple philosophy for the protocol. If a user has shorter packets it is allowed to pack out the 64k application space. Any error condition outside the protocol's ability to manage it causes the GRDDP to stop and report this condition to a higher level process.

III. GRDDP STARTUP REQUIREMENTS MISSING FROM ORIGINAL SPECIFICATION

There are five instruments on the GOES-R spacecraft covering a wide range of Earth and Solar sensing capabilities. The data rates from these instruments varies widely. The instruments started development before a spacecraft contractor was selected. This created a situation where the spacecraft provider wasn't in a position to negotiate instrument operation over the SpW GRDDP links. The instrument providers all implemented the startup operation of their GRDDP interfaces differently since the specification was not explicitly specific. This caused the spacecraft to develop unique startup processes for each instrument.

During GRDDP development and proof-of-concept testing, the GOES-R Project development system host processors were up and running long before instrument links were established. This case was reversed when the instruments were integrated with the spacecraft. The instrument's GRDDP interfaces established links with the spacecraft before their host processors were fully functional. Another difference between GRDDP development and spacecraft integration is that development system startup procedures were implemented manually where the spacecraft procedures are automated. This prevented testing during development that could have identified startup interface failures due to host processor initialization delays. Additional problems relating to instrument reset/reboot and timecode processing were encountered.

Post GRDDP development and when the instrument providers delivered emulators, integration and software verification testing proceeded using spacecraft host processors and simulators. The spacecraft simulators had functionally equivalent spacecraft SpW network routers and were used to test command products and procedures in operational configurations. This testing revealed problems with instrument reset/reboot, router flow control, and timecode processing. These issues were analyzed and resolved.

The primary and highest rate GOES-R instrument GRDDP interface establishes links with the spacecraft and buffers messages until the instrument's host processor is ready. It takes approximately 3 seconds for this instrument's host processor to reach the state where it can configure the GRDDP interface and process messages. Due to GOES-R timecode processing requirements, the instrument needs to receive time information from the spacecraft as soon as the link is established. In order to deal with these issues procedures

were created holding high rate and ancillary packets for 3 seconds. No delays were implemented for time messages.

The link to host processor startup latency issue was a problem for all GOES-R instruments. The corrective action implemented, shown in Figure 1, was creation of a programmable delay in the instrument startup procedures holding off link initialization until the host was fully operational. This programmable delay is different with each instrument and defined in spacecraft to instrument Interface Control Documents (ICD).

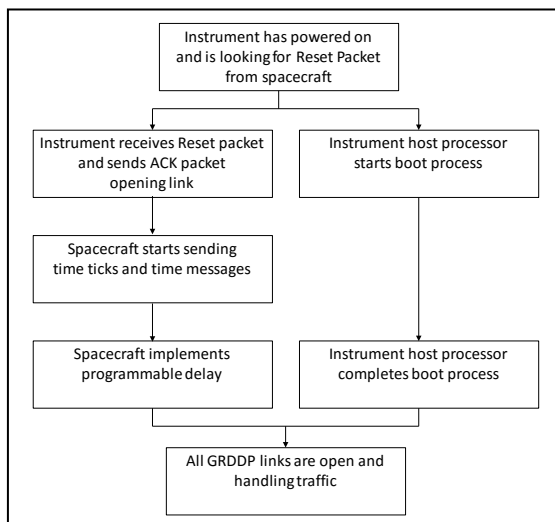

Figure 1. GOES-R GRDDP Startup Host Delay Compensation Procedure

The next highest rate GOES-R instrument is the first of four instrument nodes, as seen from the spacecraft, in an onboard network. This instrument designed their flight software to initiate an internal reset every 1.3 seconds if a spacecraft transmit channel is not opened causing a disconnect/reconnect cycle. This causes the SpW timecode hardware to lose synchronization with the other nodes on the router, since a disconnect on any port resets the six bit SpW timecode count for all ports. If this instrument's internal resets continue, the other instruments on the link will see a loss of timecode for a period of greater than ten seconds. This condition, by GOES-R requirements, causes the other instruments on the link to safe themselves. To mitigate this problem, procedures were developed that powered this instrument on and opened GRDDP channels before the other instruments sharing the same link were powered on and activated. Also, procedures diagramed in Figure 2 were implemented that powered this instrument down after shutting down the other instruments on the link.

Based on GOES-R integration experience as discussed above several modifications to the GRDDP specification are recommended. In order to deal with link to host initialization delays GRDDP users should revise the protocol with the following:

From:

7.2 Reset Command

When a Transmit (Transmit End Point) TEP transitions to the Enabled state, it shall send a Reset command to its remote Receive TEP and initiate an acknowledgement timer.

To:

7.2 Reset Command

When a Transmit TEP transitions to the Enabled state and all associated processors are fully operational, it shall send a Reset command to its remote Receive TEP and initiate an acknowledgement timer.

This compensates for link to host startup delay issues and eliminates the need for programmable delays in startup procedures.

GOES-R has implemented a dual redundant SpW architecture between the spacecraft and onboard instruments. If GRDDP users implement redundant SpW interfaces GRDDP requirements need to be added to insure transmitters and receivers are connected to the correct link.

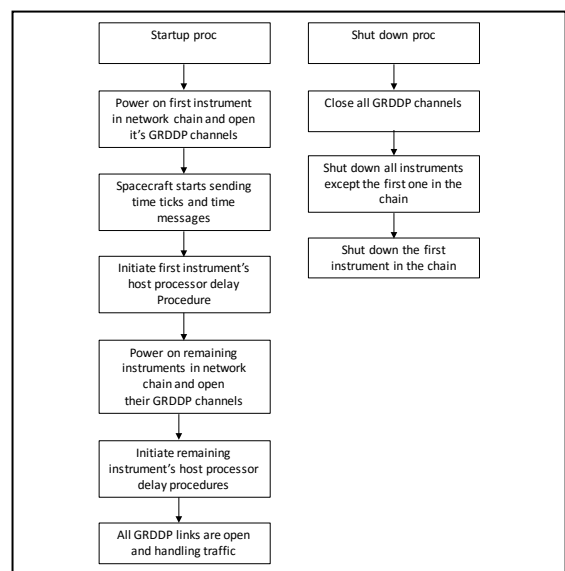

Figure 2. Startup and Shutdown Procedure

V. HEADER REVISION

IV. GRDDP PRIORITY PROCESSING

The current GRDDP requirements for transmit priority processing are as follows:

4.1.2 Transmit Priority

When more than one packet is available for transmit, all Acknowledge packets shall be transmitted first, then Reset Command packets, then Urgent Message packets, then retransmit packets, then Data packets.

4.1.3 Data Transmit Queue

When data packets from more than one channel are available for transmit, packets shall be transmitted in the order in which they are queued.

4.1.4 Urgent Message Transmit Queue

When Urgent Message packets from more than one channel are available for transmit, packets **shall** be transmitted in the order in which they are queued.

The GOES-R spacecraft uses the GRDDP UM service to distribute ancillary packets at a 100Hz rate to the primary instrument. There is a latency requirement for this ancillary data. The spacecraft implemented flight software compliant with the GRDDP specification. Due to a unique set of circumstances, this instrument's operational procedures caused delays in transmitting ancillary data packets outside the latency requirement. It was determined the ancillary packet latency requirement was more important than meeting GRDDP priority requirements. A modification was made to transmit packets that met the latency requirement and violated GRDDP requirements.

It is recommended that GRDDP transmit packet priority processing requirements be changed to allow a more adaptive design. The basis for this requirement change is that when a packet is ready and the channel is idle it should be sent immediately instead of being sent to a queue. In the case where the channel is busy the packet should be sent to a queue. As soon as the channel returns to an idle state queued packets need to be transmitted highest priority first.

The current GRDDP specification defines a single header format for all protocol packet types and is shown in Figure 3. Based on experience gained from GOES-R spacecraft and instrument integration a revision to the data packet header is proposed. In addition, an ACK packet and Reset packet header are to be added to the GRDDP. These changes enable the protocol to be more robust. Also, these recommendations improve error detection and management capabilities.

The first of these recommended header revisions is addition of a version number to all three packet types. The version number aids in detecting packets that may be in the data stream, but are not valid for a specific mission need. Inclusion of a version number replaces the user defined nibble in the original GRDDP header. The proposed GRDDP Data packet header is shown in Figure 4.

Originally it was intended that the spacecraft and instruments cooperatively develop and Interface Control Document (ICD) defining GRDDP user selectable parameters. It was assumed the spacecraft to instrument ICD would be adequate and allow "trouble free" spacecraft to instrument communications. However, as spacecraft and instrument development advanced into integration mismatches occurred. The reason for these mismatches was due to the lack of a requirement for either side to verify the other side's operation. The Reset packet header format is to be lengthened by 5 bytes and is shown in Figure 5.

This proposed Reset packet header allows a plug-and-play environment where programmable protocol parameters would be provided to protocol receivers. The receiver could optionally adaptively configure for that channel's parameters. The ACK to the Reset packet could either verify matching parameters to a predetermined configuration or indicate some requirement is beyond the receiver's capabilities.

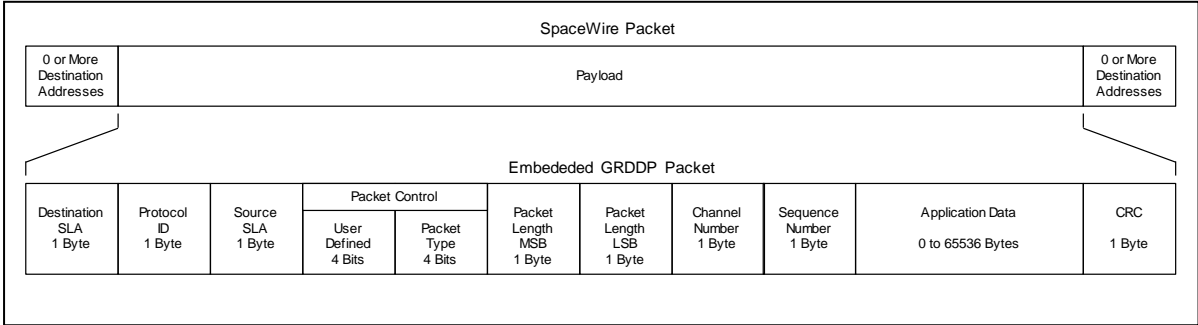

Figure 3. Current GRDDP Header

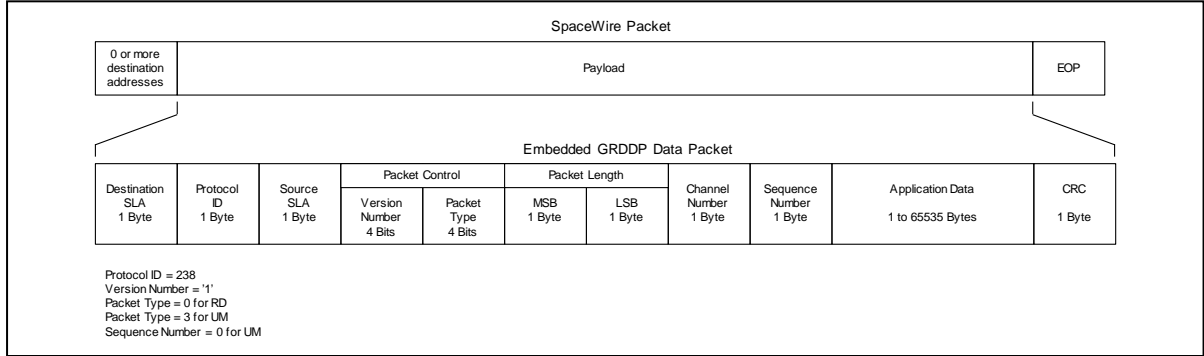

Figure 4. Proposed Data Packet Header

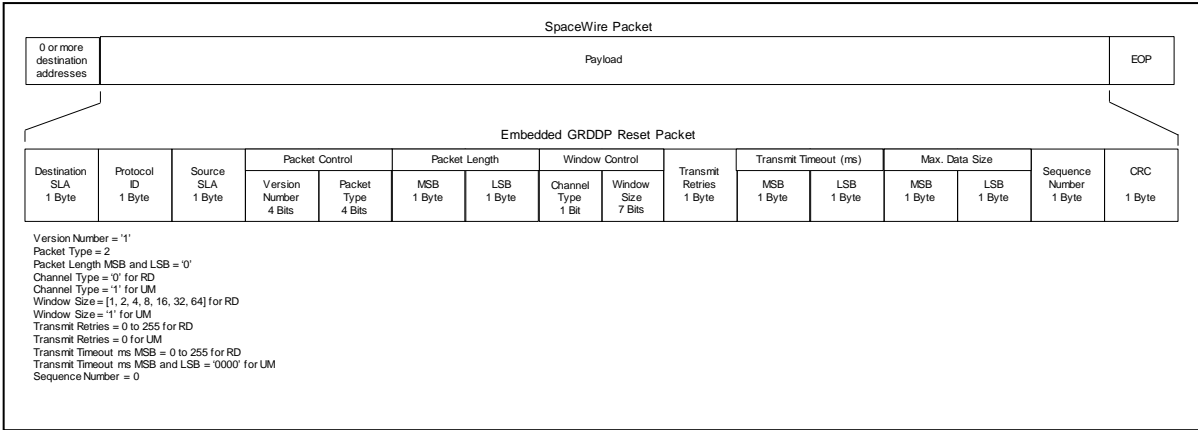

Figure 5. Proposed Reset Packet Header

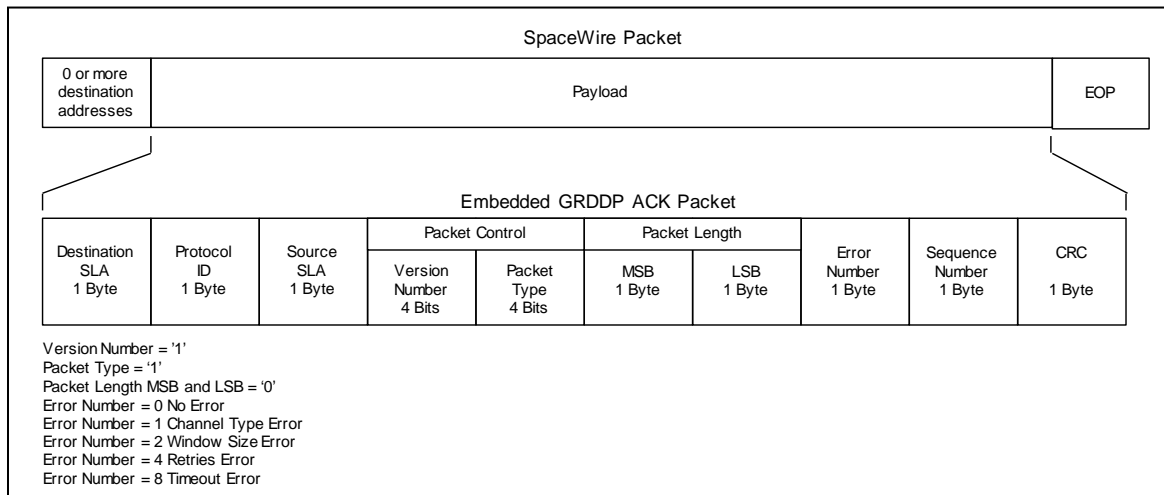

Figure 6. Proposed ACK Packet Header

VI. MISCELLANEOUS RECOMMENDATIONS

ECSS-E-50-12A, “SpaceWire – Links, Nodes, Routers and Networks,” 2003

There is no current GRDDP requirement that a channel should exclusively deliver RD or UM packets. In order to reduce the possibility of complications, it is recommended that such a requirement be added. Reset packet rate has proven to be a problem. It is recommended that a requirement be added controlling GRDDP Reset packet rate to something on the order of once a second.

It is essential that the spacecraft disable the redundant port to the instrument prior to power on. Also the instrument should initiate communications after determining which side is active based on the link’s run status. In order to eliminate programmed delays in power up sequences the spacecraft needs to detect when the instrument is “alive.” This is accomplished when the spacecraft receives a Reset packet. The next step is to open timecode and command channels. When all channels are in the Open state telemetry data should commence.

REFERENCES

- [1] NASA Goddard Space Flight Center GOES-R Project "GOES-R Reliable Data Delivery Protocol," 417-R-RPT - 0050 Version 2.1, 2008
- [2] European Cooperation for Space Standardization, ECSS-E-ST-50-51C 5, “Space Engineering SpaceWire Protocol Identification,” February 2010
- [3] European Cooperation for Space Standardization,