

Time Domain Stability Margin Assessment

Keith Clements

ERC, Inc/Jacobs ESSSA Contract/MSFC-EV41

AIAA Young Professionals Symposium, October 20-21

Huntsville, AL

Typical Control System

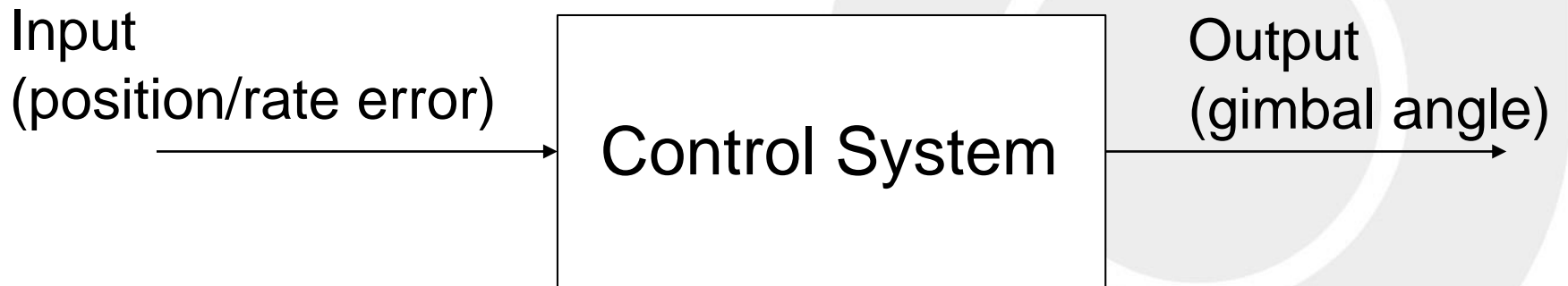

Gain Explanation

- After an input is passed to the control system, the output can be scaled relative to the input signal. The ratio of the magnitude of output/input is called the Gain.
- The gain can be expressed in dB, which is done by doing the operation: $20 \cdot \log_{10}(\text{gain})$.

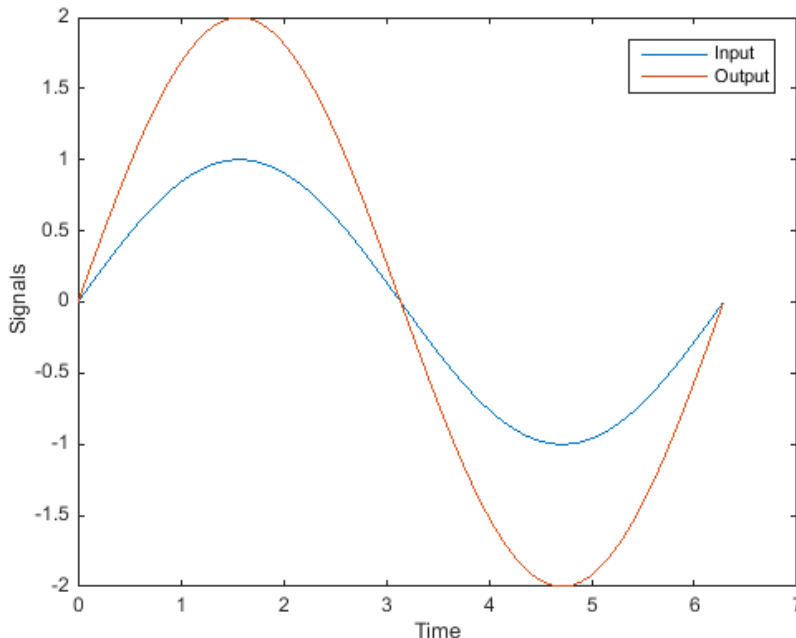

In this example, the ratio of the peaks is 2, so we'd say the gain is 2.

The gain in dB would be $20 \cdot \log(2) = 6.02$ dB.

Phase Explanation

- The output can also experience a “lag” or “delay” due to the control system. This is known as the phase.
- The phase is usually expressed in degrees. This is done by finding the time delay and using the formula: $\text{phase} = 360 * \text{frequency} * \text{delay}$

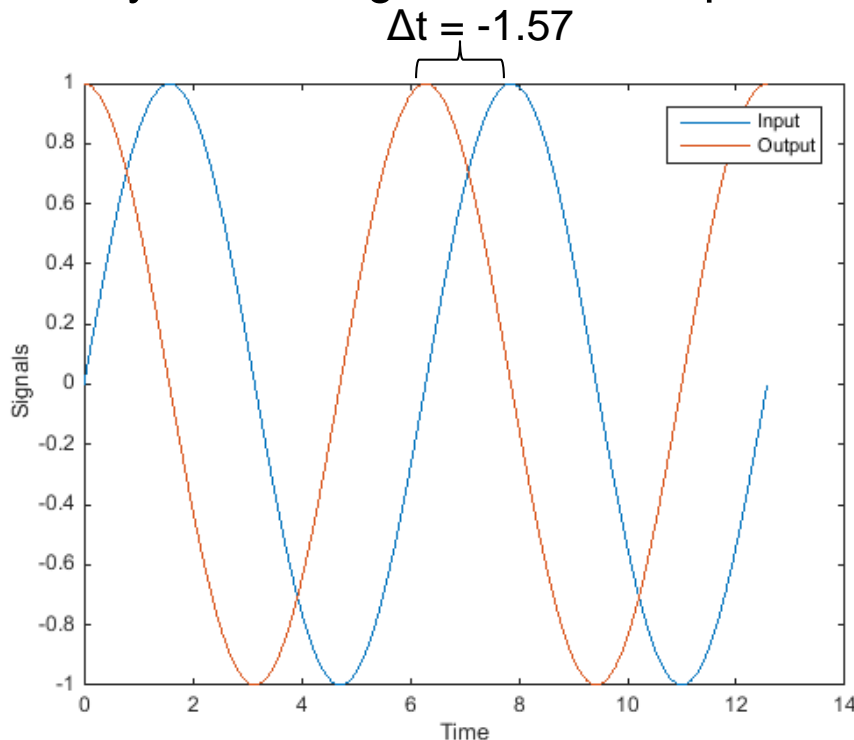

The phase of this system is
 $-360 * 1/6.28 * 1.57 = -90^\circ$

Gain and Phase Margins

- A system itself can have a number of uncertainties in it (mass properties, sensor measurements, etc). For large systems, many uncertainties can arise.
- The gain and phase margins are the quantities that define how close a system is to becoming unstable.
- An instability occurs when the gain of the system reaches 0 dB (or greater) at the same time that the phase reaches -180 degrees.
- The gain and phase margins are built into the system in order to prevent an instability from occurring due to modeling uncertainties or differences when the real system is built (for SLS, minimum phase margin is 30 deg and minimum gain margin is 6 dB).

Nichols Chart

- The Nichols Chart is a tool that helps easily determine the gain and phase margins. This example shows a simple simulated system with gain and phase margin co-plotted with what the “real” system might look like.
- In this presentation, time delays will be converted to phase values by using the *crossover frequency*. This is the frequency associated with the phase margin (0.459 Hz in this example).

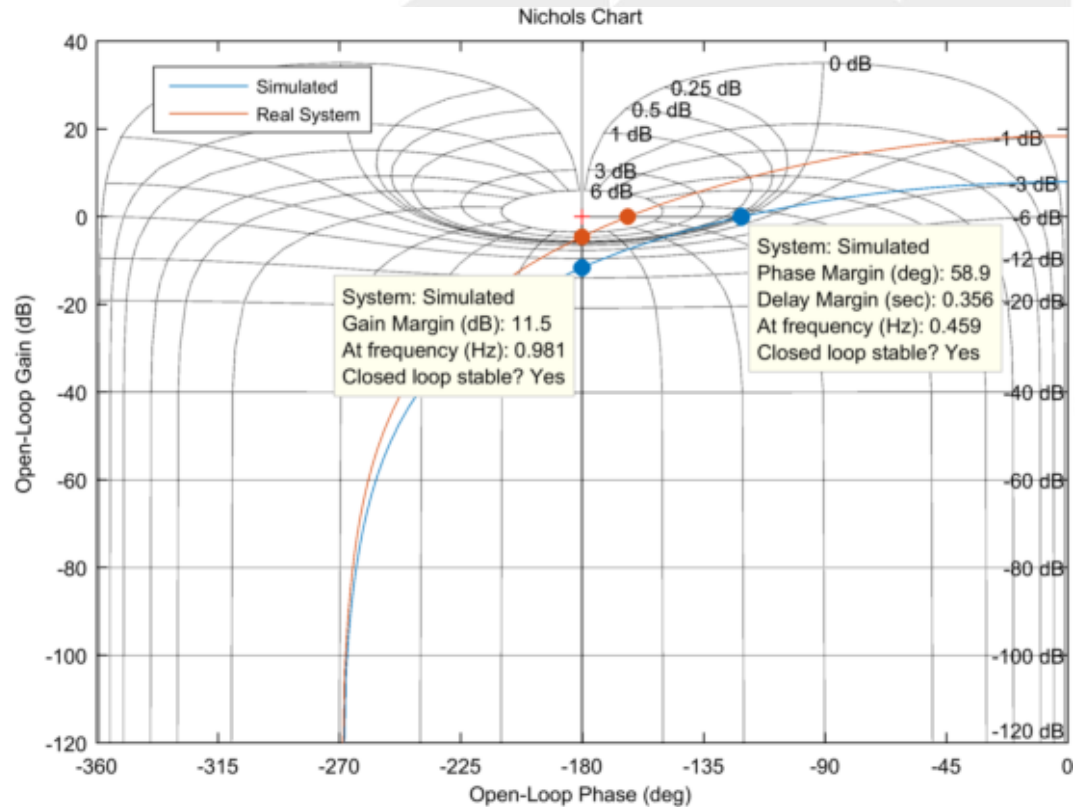

Introduction

- The Gain and Phase margins of a system are essential metrics in the control system design and analysis branch. These give us an idea of how robust our system is to uncertainties in the system modeling vs. real life applications.
- The Control Systems Design and Analysis Branch (EV41) at MSFC has a few analysis tools to compute these margins. The primary tool is called FRACTAL (Frequency Response Analysis and Comparison Tool Assuming Linearity).
- The full 6-dof simulation is done in a tool called MAVERIC (Marshall Aerospace VEHICLE Representation in C).
- Previously, no work had been done to verify the margins computed in FRACTAL in the time domain.

Purpose

- The primary goal of this study is to analyze the effects of the augmenting adaptive control (AAC) in the system as well as highlight the pros and cons of the time domain stability margin assessment.
- AAC increases robustness to unanticipated dynamics by adjusting control gains when attitude/rates are significantly different from a high fidelity reference model.
- AAC can ideally help recover up to 6 dB of gain margin in the system; however, in doing so, the phase margin can be reduced by an undetermined amount.
- The following cases were run to gain more insight into the system:
 - AAC on/off – AAC off is basically just verifying the stability margins, and AAC on will show how AAC can help recover an unstable system.
 - Gimbal limits on/off – Allowing the gimbal limits to go beyond 8 degrees lets the system perform to its maximum capabilities. The limits-on cases give more realistic simulations.

Gain and Phase Modification in the Time Domain

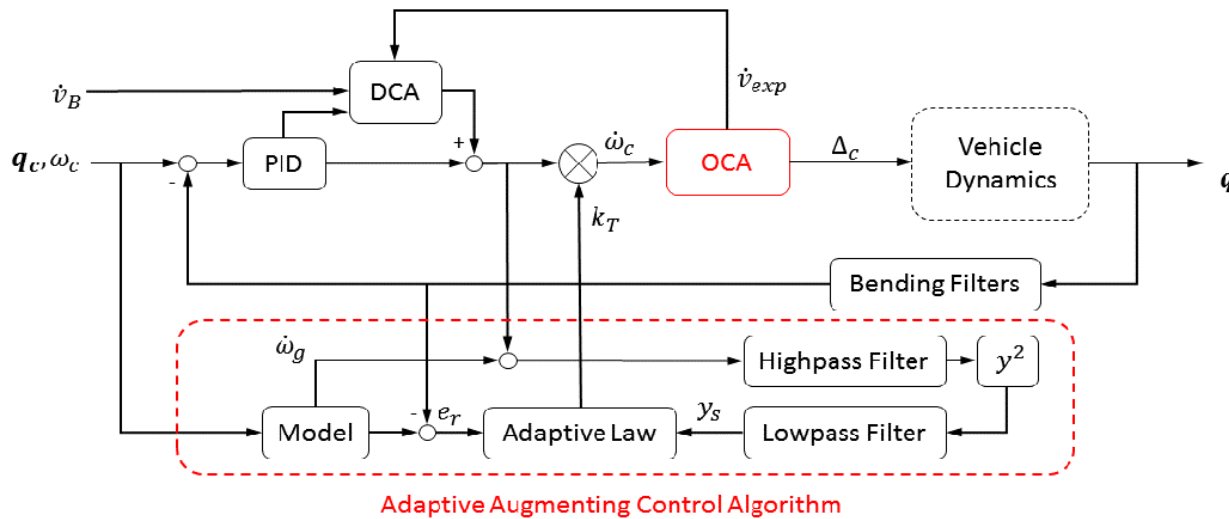

Modification is done within the optimal control allocator (OCA)

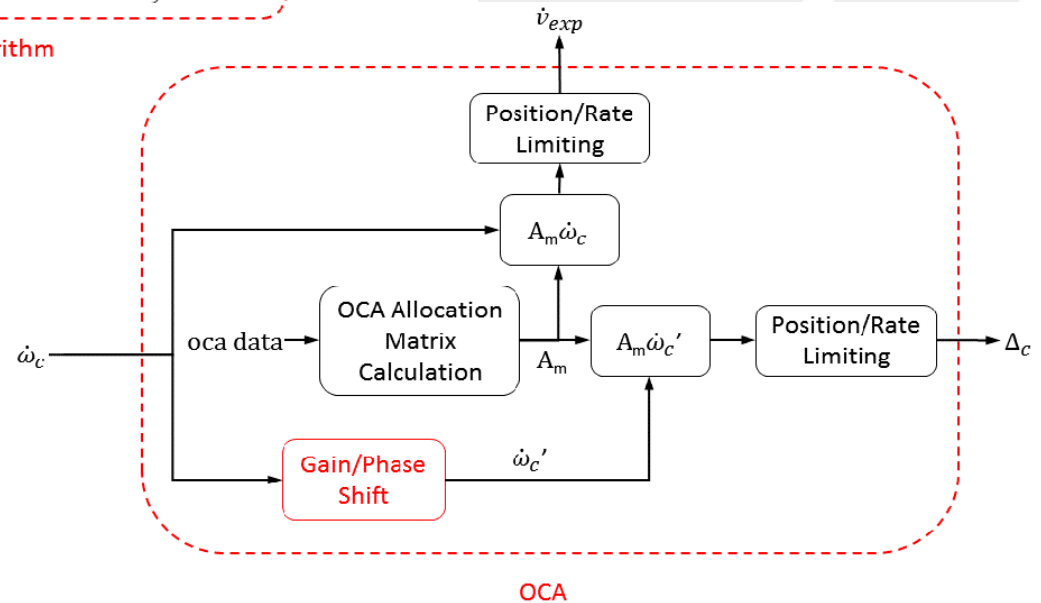

Rigid Body Gain Margin Method

- The stability margins were evaluated every second throughout ascent flight and stored as a function of time.
- The overall gain of the system was artificially increased to the neutral stability point at each time step and then adjusted to some value +/- the neutral point. The figures below show how the rigid gain margins are applied (Note, numbers are removed on most of these plots due to ITAR restrictions).

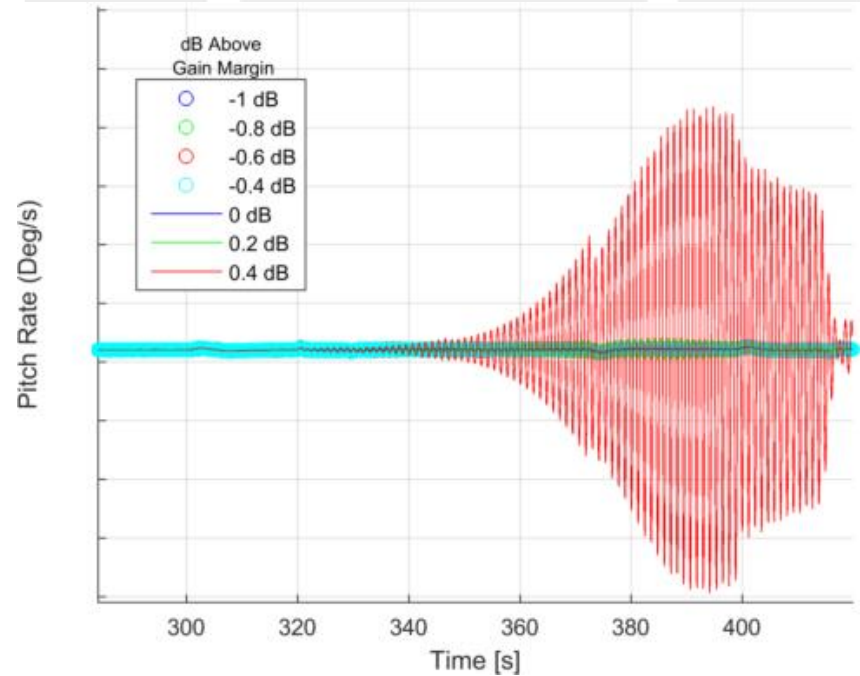
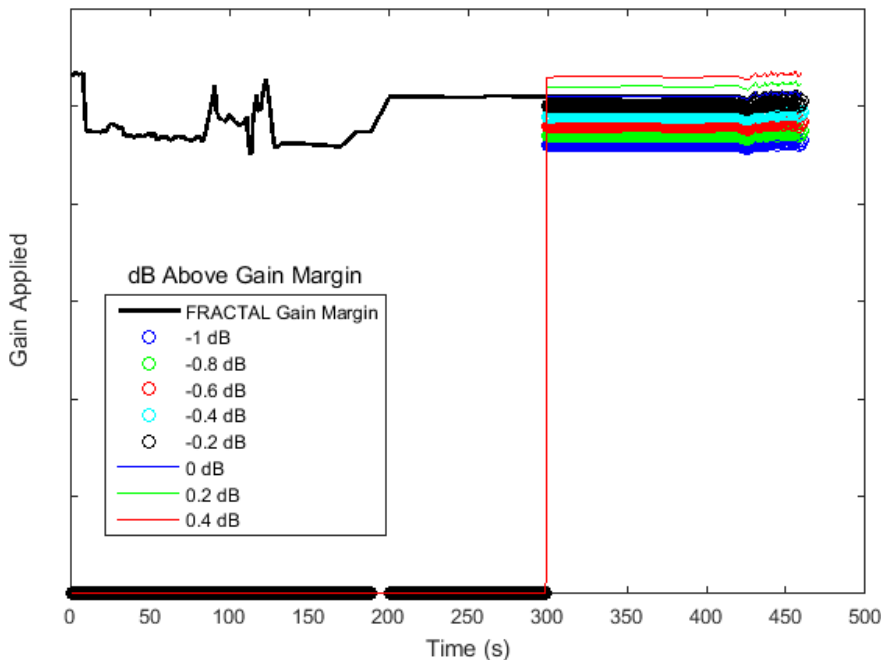

Aero Gain Margin Method

- The aero gain margins test the effect of lowering the gain to reach instability
- The overall gain of the system was artificially decreased to the neutral stability point at each time step and then adjusted just like the rigid gain margins. The figure below show the aero gain margins as a function of time.
- Due to the quickly varying nature of the boost phase aero gain margin and the much slower time constant of the corresponding instability, initial attempts at identifying the aero margin in boost phase proved inconclusive; therefore, these time points are omitted from this presentation.

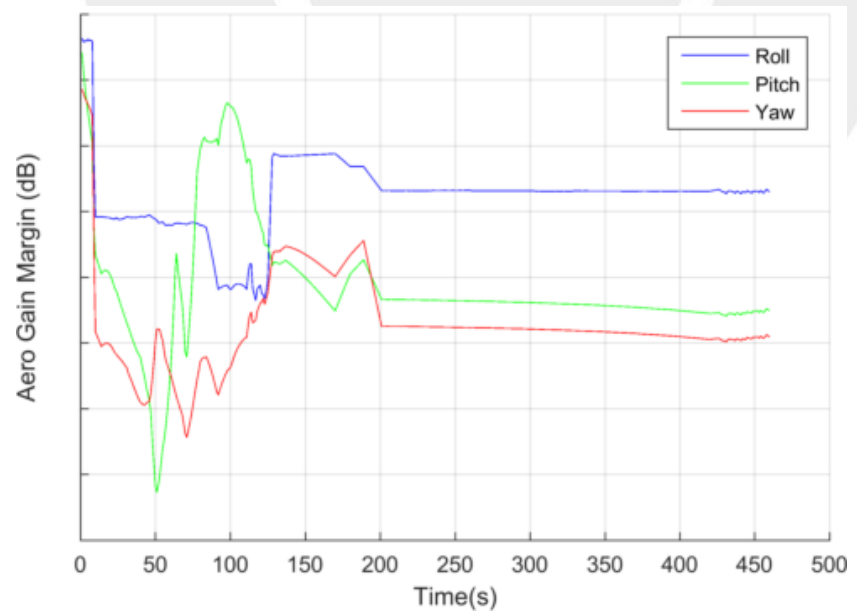

Phase Margin Method

- When assessing the rigid-body phase margin, a constant time delay was applied to the system starting at the time point under consideration. This delay was converted to a phase in degrees by the formula: $\varphi_{deg} = 360(\omega_{cr})(t_d)$, where ω_{cr} is the crossover frequency and t_d is the time delay being tested.
- Since the linearized phase margins vary in time, it is not possible to adjust the phase to neutral stability as was done with the rigid body gain margins. This is because a constant delay needs a few cycles for an instability to appear.
- Inaccuracies in the phase margin assessment can arise in regions of rapidly-varying phase margin.

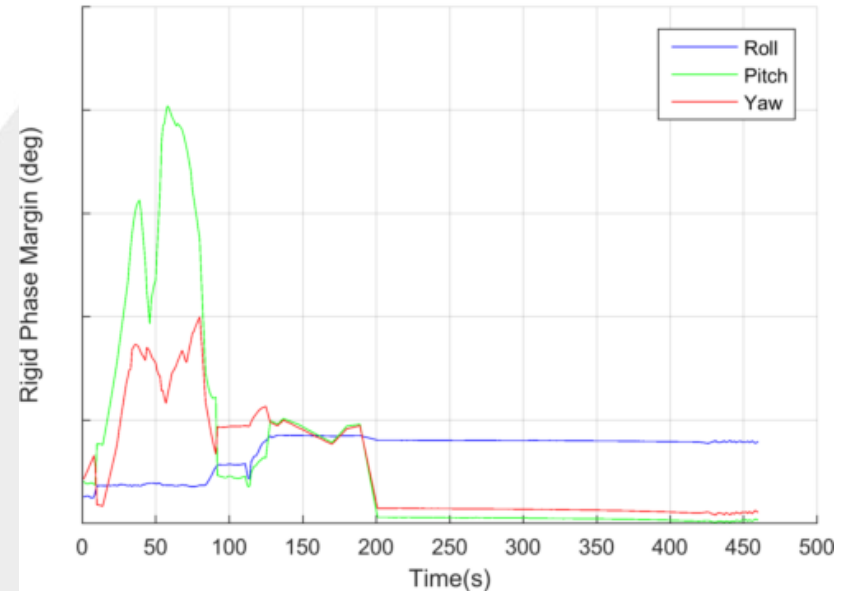

Time Points Analyzed

- The operating points were chosen to assess the three main phases of flight.
 - Boost Flight - 70 Seconds
 - Core Flight, Pre-LAS Jettison - 140 Seconds (phase and aero gain margin assessment) and 180 seconds (rigid body gain margin assessment)
 - Core Flight, Post-LAS Jettison – 300 Seconds
- For each time point, the gain was varied in 0.2 dB steps, and the delay was applied in 0.02 second increments (50 Hz frame delay).
- The stability margin was found through a numerical assessment of the time domain results.
- The metrics and method for assessment of instability depends upon the type of stability margin being verified and the configuration of the system.

Variables Assessed

- In order to determine the first simulation that displays unstable behavior, a set of variables was created to fully assess the instabilities.
- **Body Rates** (p , q , or r): These are the main indicators of instability. If the axis under investigation displays divergent oscillations in its body rate, it is said to be unstable.
- **Max engine saturation ratio**: This variable measures the maximum of the ratio of the commanded gimbals angles to that of the actual gimbals angles. If the max engine saturation ratio is larger than one, the system has reached gimbals angle saturation. For cases with gimbals limits enabled, this will likely lead to an instability. For cases with gimbals limits off, divergent behavior of this variable is indicative of an instability.
- **Adaptive Gain**: For cases with AAC enabled, this variable is a good indicator of instability. If the adaptive gain is saturated (either 2.0 or 0.5), it is no longer improving the performance of the system. If this is the case for long enough (usually about 10-15 seconds), the system will often become unstable.

Plots of Assessed Variables

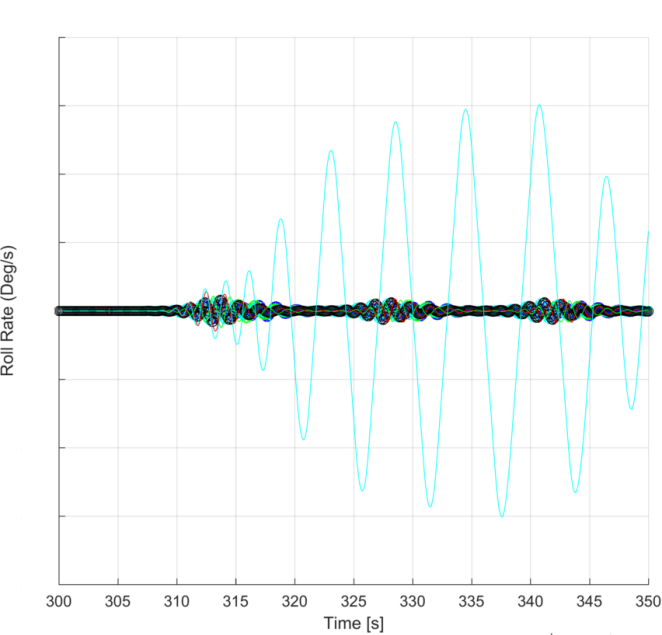

Rigid Body Gain Instability Example

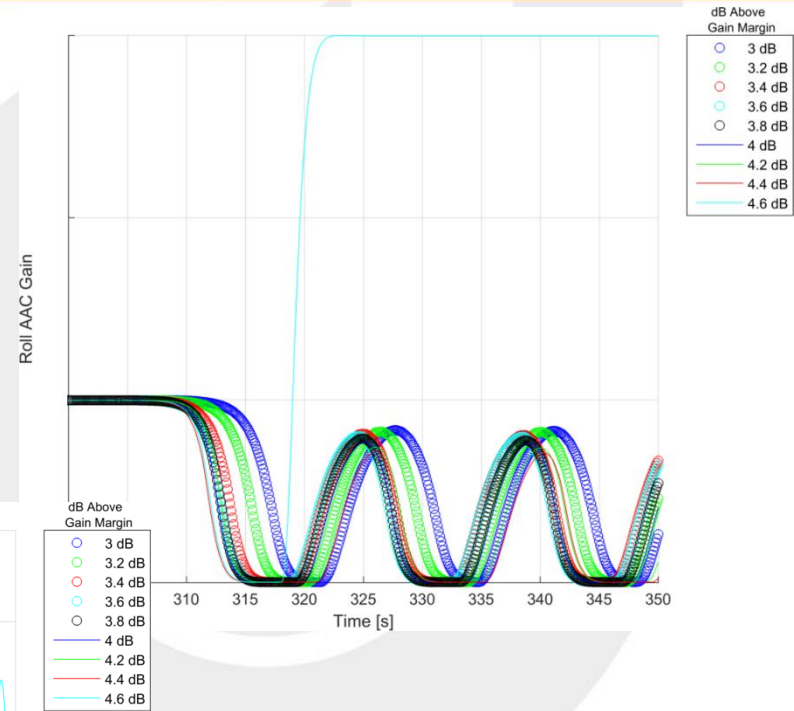
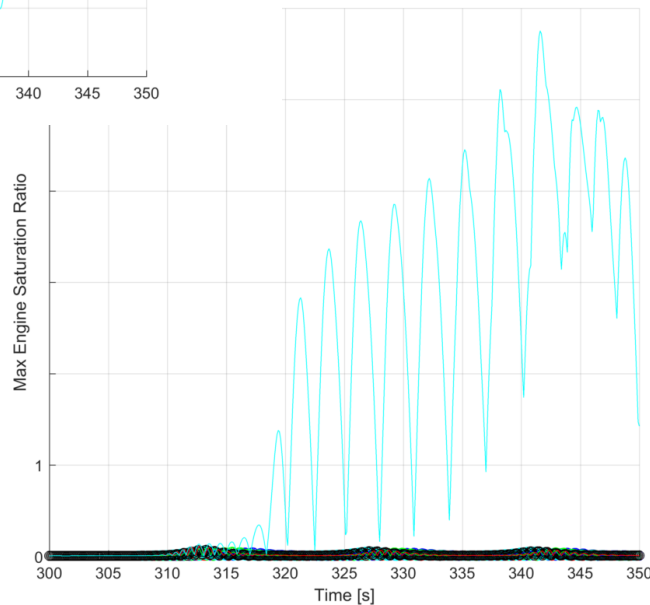

Results

- The method described in the previous section was applied to configurations in which AAC was enabled or disabled and limits to gimbal angle and rate commands issued by the controller were enabled or disabled.
- Since AAC is expected to increase gain margins by 6 dB, the baseline gain margin with AAC enabled are the same curves as with AAC disabled but with an additional 6 dB.

Results

Rigid Body Gain Margins

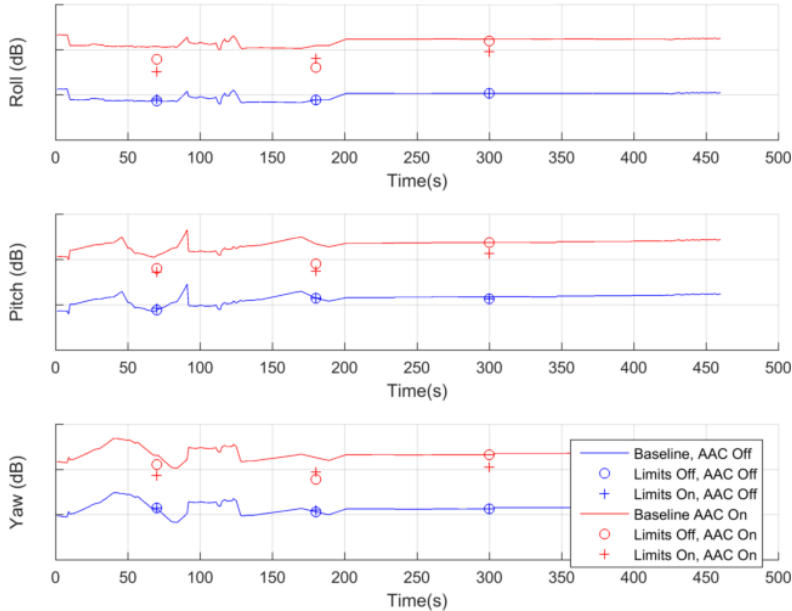

Phase Margins

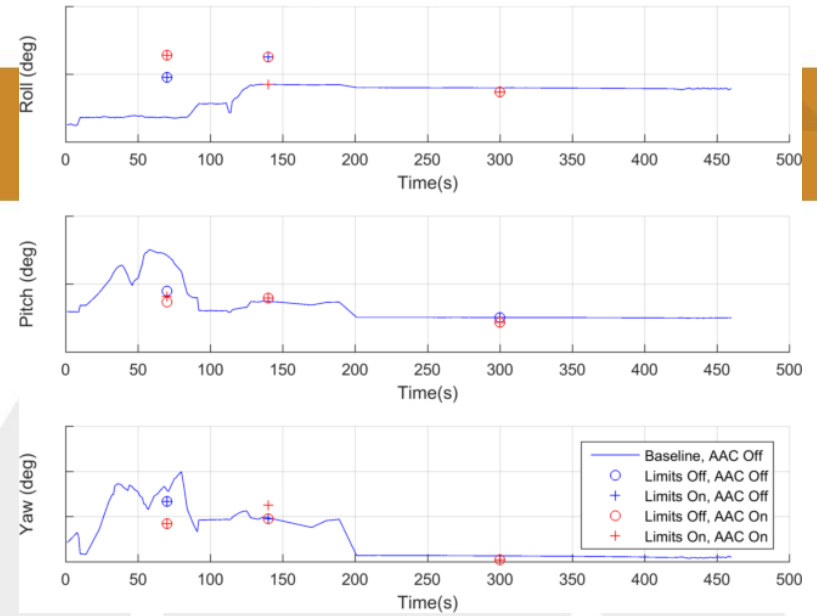

Aero Gain Margins

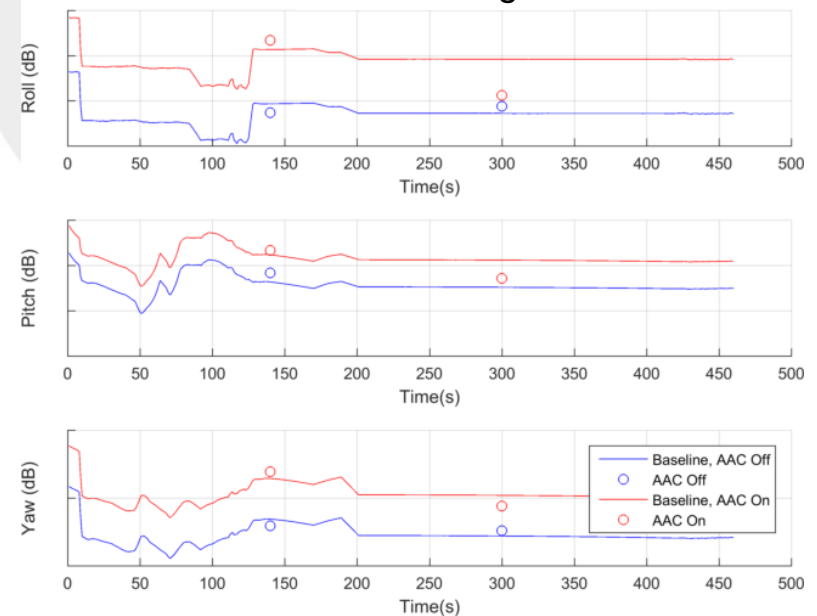

Results

Margin	Axis	Limits	Time (sec)			
			70	140	180	300
Rigid Gain Margin Difference(dB)	Roll	On	0.2	-	0	0
		Off	0	-	0	0
	Pitch	On	0.2	-	0	-0.2
		Off	0	-	0	-0.2
	Yaw	On	0.2	-	0.2	0
		Off	0.2	-	0	0
Aero Gain Margin Difference (dB)	Roll	Off	N/A	-1	-	0.8
	Pitch	Off	N/A	2	-	2
	Yaw	Off	N/A	-1	-	0.8

Margin	Axis	Limits	Time (sec)			
			70	140	180	300
Rigid Gain Margin Difference(dB)	Roll	On	3.2	-	4.6	4.6
		Off	4.6	-	3.6	5.8
	Pitch	On	4.2	-	3	4.8
		Off	4.6	-	3.8	6
	Yaw	On	3.8	-	4.4	4.6
		Off	5	-	3.6	6
Aero Gain Margin Difference (dB)	Roll	Off	N/A	7	-	2
	Pitch	Off	N/A	7	-	2
	Yaw	Off	N/A	7	-	4.4

Significant Findings – AAC Recovery of Gain-Unstable Systems

- A primary goal of this study was to observe the ability of AAC to recover gain-unstable systems. Across all cases tested, the gain margins from instability was increased by at least 4 dB in the MAVERIC time domain.
- Example of AAC recovering 6 dB of gain margin:

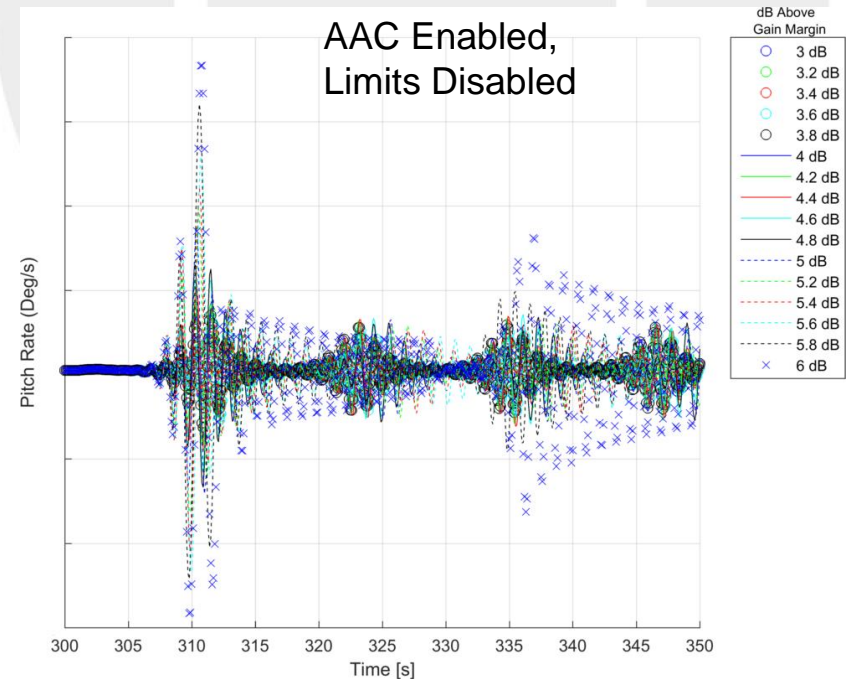
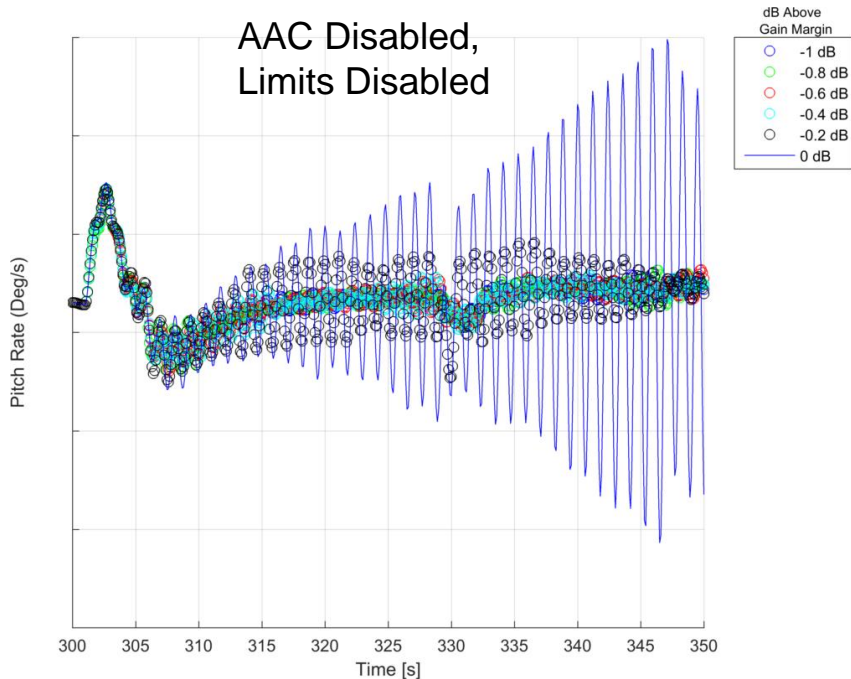

Significant Findings – Degradation Associated with Limiting

- Intuitively, it makes sense that a system will become unstable at lower magnitudes of gain or phase degradation if limits are applied to the command gimbal angles and command gimbal rates than it would if there were no limits applied.
- Example:

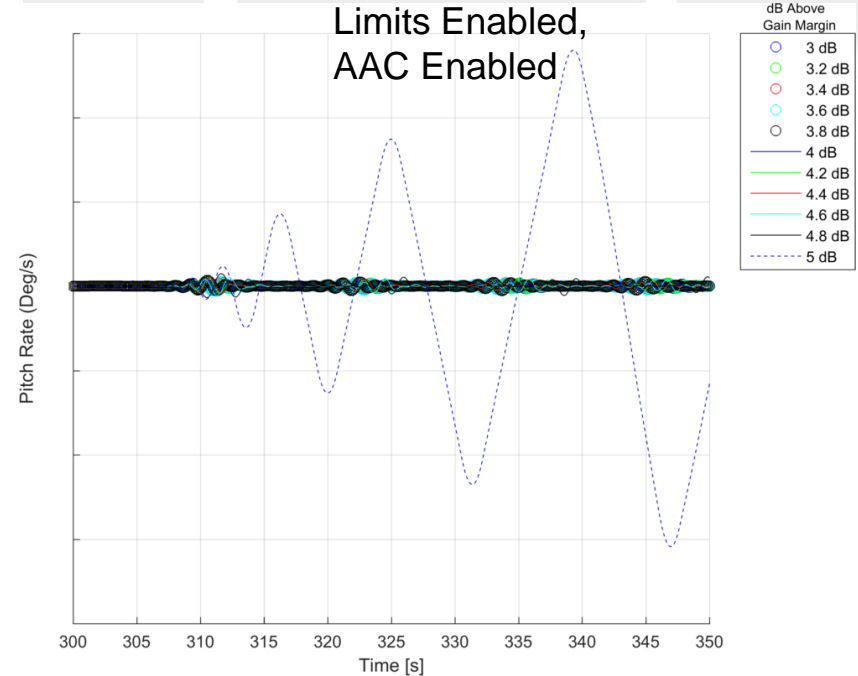
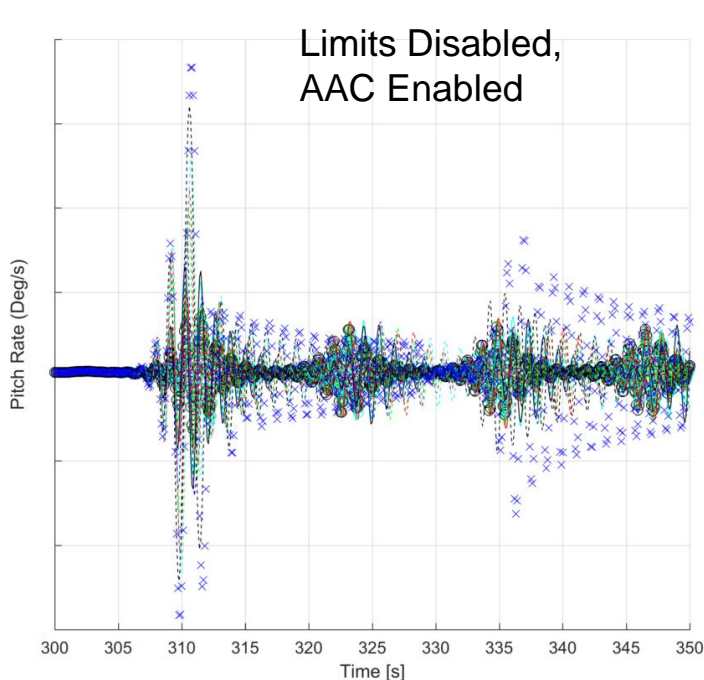

Significant Findings – Degradation Associated with Limiting

- The degradation associated with limiting is almost exclusively seen in the rigid body gain instabilities. This is likely due to the rapid divergence of these instabilities resulting from the low damping of the control response near its second phase crossover.
- In some cases, the rigid phase margins are slightly affected by the gimbaling limiting, but most cases show little to no degradation owing primarily to the very lightly damped response of the system without phase margin

Limits Disabled

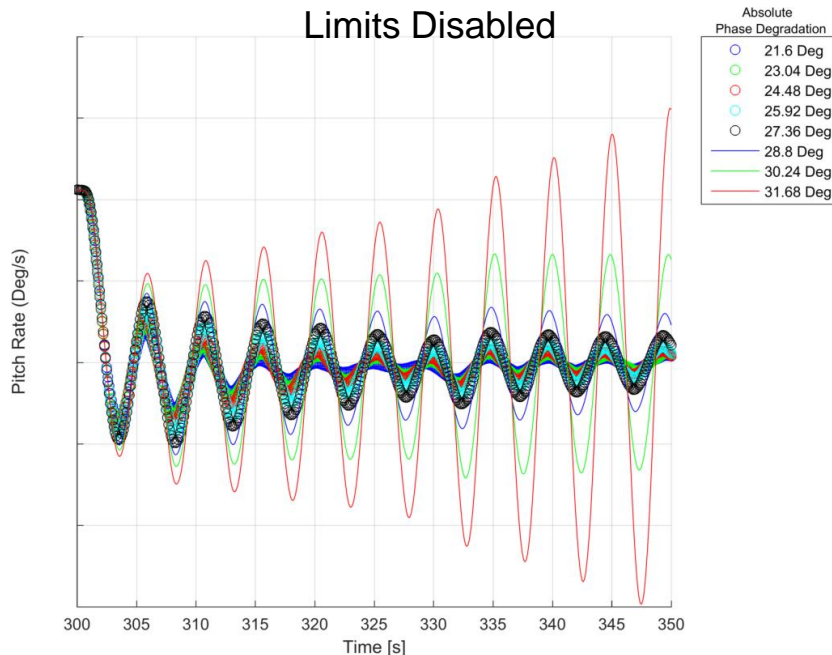

Limits Enabled

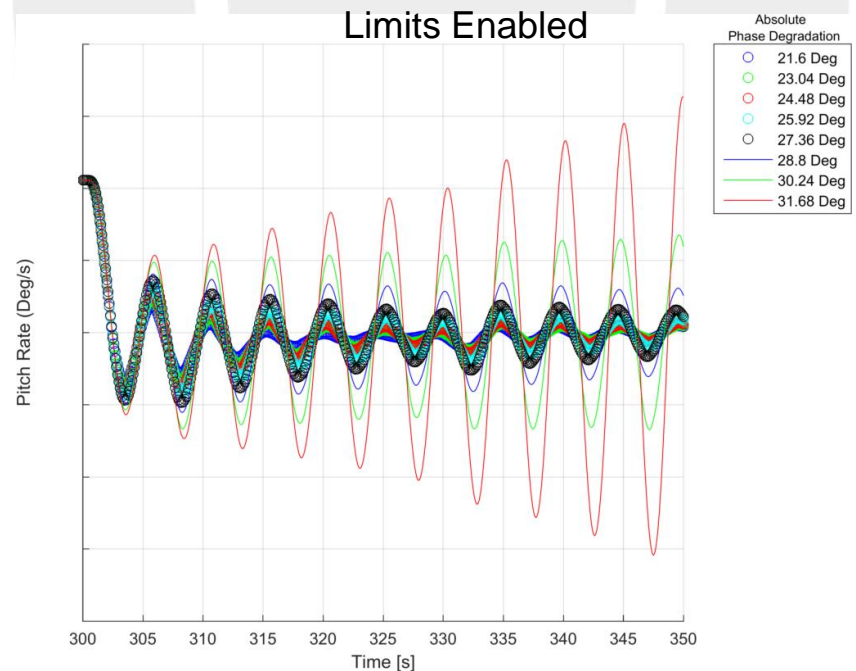

Difficulty in Assessing Aero Gain Margin

- Due to the low frequency nature of the aero gain instabilities, it was difficult to assess the exact point where instability began to occur in a lot of these tests. The frequencies of these instabilities were on average less than 0.1 Hz, so it took at least 100 seconds to see 10 cycles of the instabilities (about 10x longer than the rigid body gain instabilities).

Fairly obvious that 0.2-0.4 dB is unstable

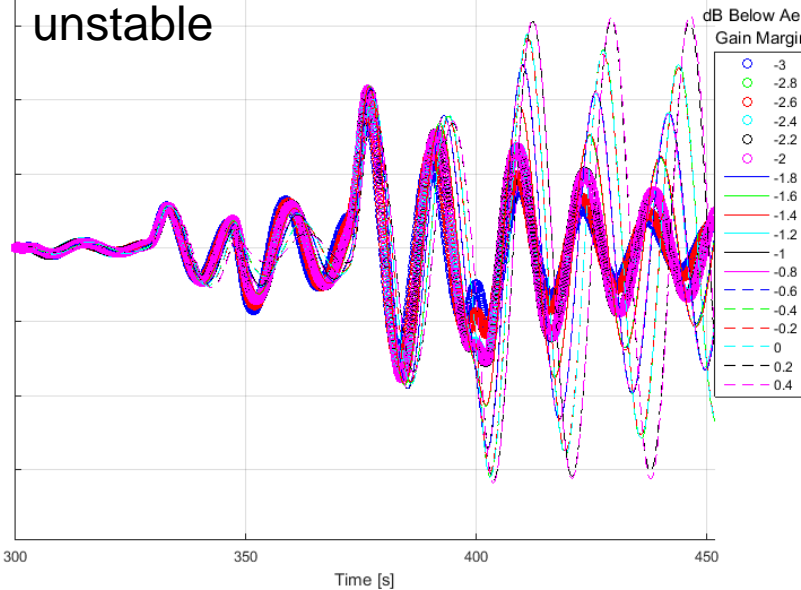

Very ambiguous

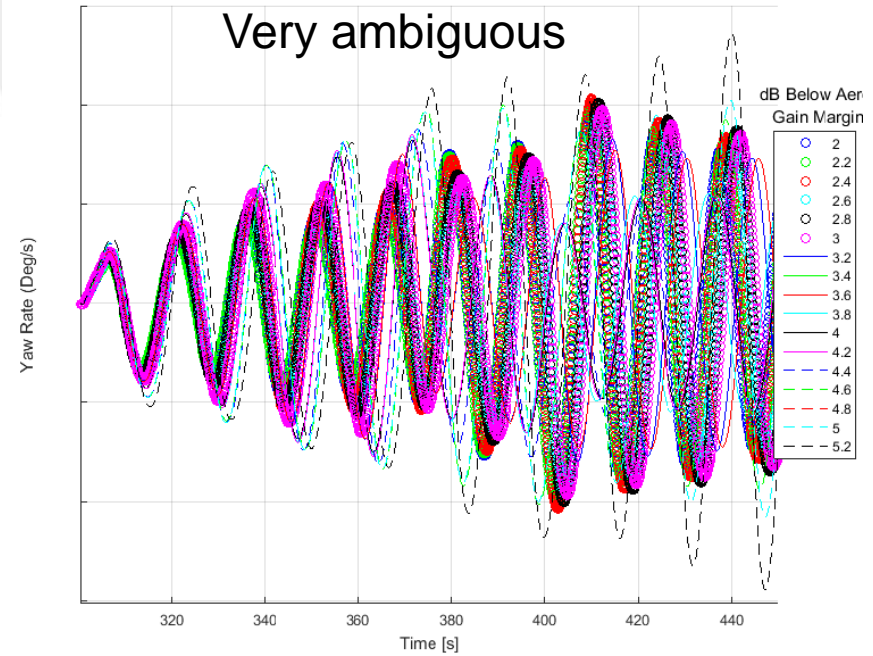

Conclusions

- The gain and phase margins derived from the nonlinear time domain simulations demonstrate good overall agreement to the frequency domain LTI-derived margins. Ignoring AAC for the moment, this validation of the mainline SLS frequency domain analysis is a noteworthy finding
- AAC will recover rigid body gain instabilities beyond those derived in the frequency domain. AAC has been shown to recover at least half of the theoretical 6 dB of rigid body gain margin in the time domain.
- AAC has the potential to decrease the phase margin. The shape of the Nichols chart and the magnitude of gain variation will determine the precise amount of phase degradation caused by AAC. In MAVERIC, the magnitude of this degradation was no more than 2-4 degrees at the time points under consideration.
- The gimbals limiting decreases the ability of AAC to recover rigid body gain instabilities. A minimum of 2.8 dB of extra rigid body gain recovery is seen when gimbals limits are enabled. These limits don't considerably affect the phase margins due to the low frequency nature of the instabilities.

Shortcomings and Future Work

- The phase margin evaluation in highly dynamic regions will often cause a mismatch with those margins derived in the frequency domain.
- It is often difficult to pinpoint the exact magnitude of instability when assessing the aero gain margins.
- In the future, it is desirable to add error bars to the points on the plots of results. Since there's some ambiguity associated with the point of instability, it would be ideal to show the range of possible instabilities.
- Possibly find new metric for determining aero instabilities – this could reduce uncertainty in assessing this margin.



Shaping the Future of Aerospace