

Thermal Testing and Model Correlation for Advanced Topographic Laser Altimeter Instrument (ATLAS)

Deepak Patel
Goddard Space Flight Center,
Greenbelt, Maryland

ABSTRACT

The Advanced Topographic Laser Altimeter System (ATLAS) part of the Ice Cloud and Land Elevation Satellite 2 (ICESat-2) is an upcoming Earth Science mission focusing on the effects of climate change. The flight instrument passed all environmental testing at GSFC (Goddard Space Flight Center) and is now ready to be shipped to the spacecraft vendor for integration and testing. This topic covers the analysis leading up to the test setup for ATLAS thermal testing as well as model correlation to flight predictions. Test setup analysis section will include areas where ATLAS could not meet flight like conditions and what were the limitations. Model correlation section will walk through changes that had to be made to the thermal model in order to match test results. The correlated model will then be integrated with spacecraft model for on-orbit predictions.

KEY WORDS

TVac: Thermal Vacuum
Qualification Testing
Thermal Balance Testing
Environmental Testing

INTRODUCTION

ATLAS is a sole instrument aboard ICESat 2 mission. Currently planned for launch in 2018, it is specifically intended to quantify the amount of change in ice sheets and sea ice and provide key insights into their behavior. It will achieve these objectives through the use of precise laser measurements of surface elevation, building on the groundbreaking capabilities of its predecessor, the Ice Cloud and Land Elevation Satellite (ICESat). In particular, ICESat-2 will measure the temporal and spatial character of ice sheet elevation change to enable assessment of ice sheet mass balance and examination of the underlying mechanisms that control it.¹

ATLAS was tested through bakeout, thermal cycle, and thermal balance. Thermal vacuum testing can include both thermal vacuum cycling and thermal balance testing. Thermal cycling exposes the instrument/test article to temperature extremes that maintains the hardware within the “elastic” region while operational. Thermal balance exposes the hardware to a flight-like

environment to allow for thermal model correlation. Model correlation is then used to better predict flight temperatures as requested by system engineers.

ATLAS Thermal vacuum testing consisted of three qualification cycles and four thermal balances. After the instrument level testing campaign, the next step is observatory integration and testing campaign. ATLAS is scheduled to launch in mid-2018.

ATLAS THERMAL DESIGN

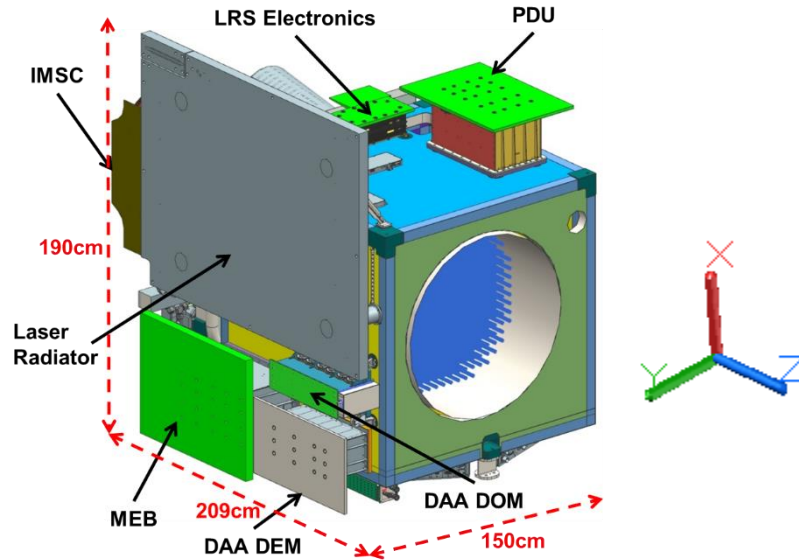

Figure 1: ATLAS Instrument

ATLAS instrument is a nadir-pointing science mission. This configuration provides two areas where the radiators can be placed due to a direct view of deep space (desired radiative environment). Figure 1 shows the instrument with its three-axis. The plus Y axis has the Laser radiator which dissipates a maximum of 150W; the MEB (Main Electronics Box) radiator dissipates a maximum of 85W; the DAA (Detector Array Assembly) DEM (Detector Electronics Module) dissipates a maximum of 65W, and DOM (Detector Optics Module) dissipates a maximum of 1.8W. The plus X has three radiators, the PDU (Power Distribution Unit), LRSE (Laser Reference System Electronics) box and LRS-O (optics). The PDU dissipates a maximum of 46W, LRSE dissipates a maximum of 9W and the LRS Optics, not shown in Figure 1 dissipates a maximum of 0.9W.

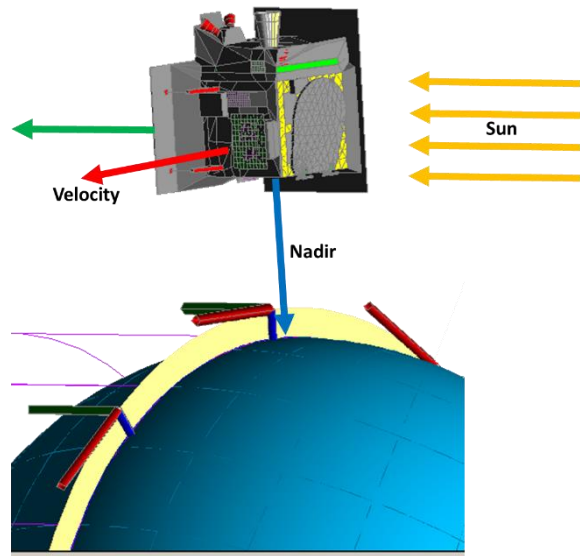

Figure 2: ATLAS in High Beta Angle

All the high dissipation electronic boxes have dedicated radiators mounted directly to them with the exception of lasers. Lasers have a CCHP (Constant Conductance Heat Pipe) connecting to an LHP (Loop Heat Pipe) which routes to the laser radiator.

ICESat2 is a polar orbiting mission which will expose ATLAS through all beta angles. Through analysis, it was determined that for model correlation the optimal cases would be the combination of the least varying environment and a highly varying. For thermal balance, beta angle 70 and 0 were chosen for hot operational cases (high power) and beta angle 90 was chosen for the cold operational case and survival condition. Beta 90 orbit is shown in Figure 2.

TVAC TEST PREDICTION REQUIREMENTS

Due to test setup limitations and modeling errors, the predicted temperatures for thermal balance and thermal cycling will have a certain level of uncertainty. In order to bound these uncertainties, there are requirements enforced to temperature and heater power predictions.

Table 1: Tvac Prediction Requirements

Requirement Description		Requirement Value
Temperature	Thermal Balance	+/-2 degC
	Thermal Cycling	+0/-2 degC for Hot Qualification +2/-0 degC for Cold Qualification
Heater Power	Thermal Balance and Cycling	+/- 10%

For components that did not meet these requirements, a waiver was written to justify whether it was a critical component and the impact to either not achieving qualification temperature or balance temperature.

TVAC FIXTURE DESIGN

The design of the ATLAS TVac fixture was driven by two factors:

1. During thermal balance: Achieve flight like temperature gradients and maintain heater duty cycle within given requirements
2. During thermal cycle: Expose all flight components qualification temperatures

The fixture design began with exporting of ATLAS thermal model into a standalone thermal platform, without the orbital parameters. Next, cryopanel were modeled for the plusX side, where the PDU, LRSE and LRSO radiators were facing and plus Y side where the MEB, DAA, DOM, and the laser radiators were facing. The setup with only the plusX and plusY cryopanel, in magenta color, is shown in Figure 3.

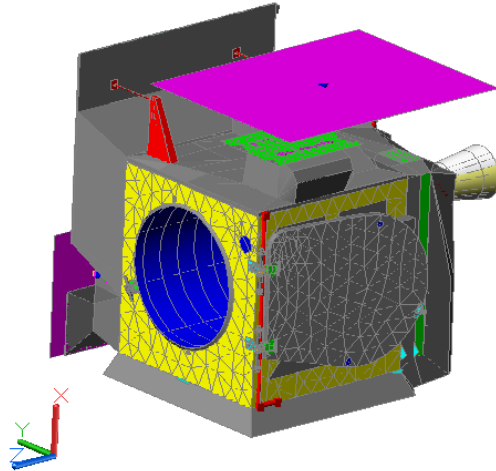

Figure 3: ATLAS Thermal Model with +X and +Y Cryopanel

After performing thermal analysis to verify whether all flight like temperatures met the requirements as defined in Table 1, the next step was to instrument further and “close-in” on the predictions. Through multiple iterations, while continuously checking against requirements, the final setup included cryopanel on plusX and plusY; two heater panels on minusY; one heater panel on minusZ; and one heater panel on plusX. The final setup is shown in Figure 4.

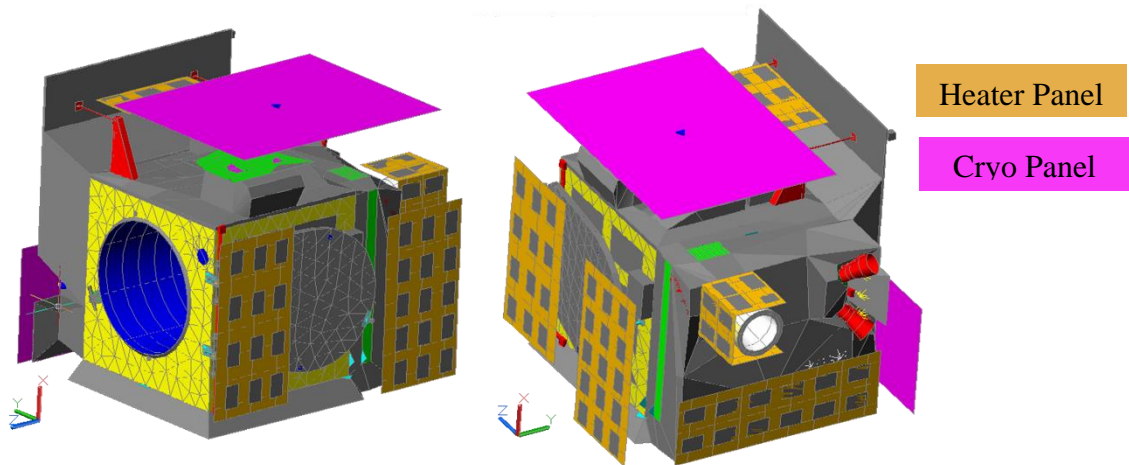

Figure 4: Final Test Panels Configuration

The panels on minusY side were driven by the flight cases where the sun illuminates on this surface. **Error! Reference source not found.** shows a case, beta 90, where the sun hits minusY surface directly. These panels also maintained the temperature of the door within qualification temperatures. Without these panels, the door would view the shroud which is almost 60degC colder than door survival limit. The minusZ panels, especially the one covering the baffle was also driven by sun illumination. Without the LRS heater panel, the C-shaped panel on minusZ side, the temperature of the baffle would’ve been driven lower than its survival temperature range due to full view to a -120 degC shroud in some cases.

Lesson learned #1:

Always track temperature sensors along with temperature averages of the components. Due to the limitations of temperature sensors instrumentation, it is easy to overlook component, with large surface areas, driven to survival temperatures.

The plusX heater panel was driven by the heat being reflected from the back side of laser radiator MLI (multi-layer insulation) onto plusX MLI as noted “X1” in Figure 5 . The main purpose of this panel was to simulate the on-orbit heating to allow the components under the blanketing (MLI) to achieve flight like temperatures and heater power. This panel was the most difficult to discover, due to the complexity of heat flow between blankets. A heat map was generated in order to understand why the components under the MLI were not meeting temperature and heater power requirements. Through various grouping methods to weed out the heat affecting the X1 area, it was determined that the critical heat flow is not between components and blankets, it is in-between blanketing. For example: the blanket from the right of X1 was reflecting heat onto the blanket underneath X1.

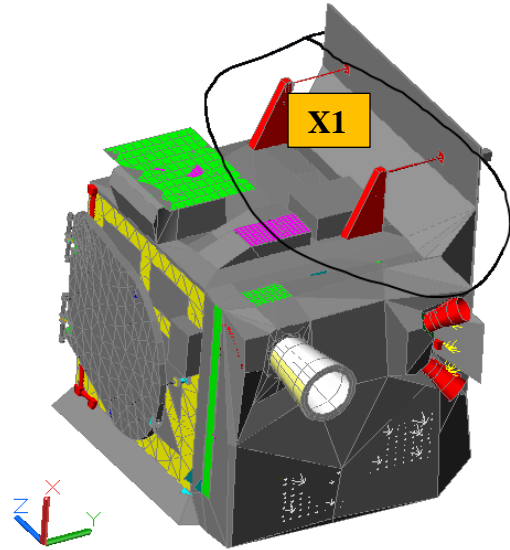

Figure 5: PlusX Heater Panel Location of Interest

Lesson learned #2:

Whenever developing a heat map, isolate blankets that have view to other blankets.

LIMITATIONS DUE TO TEST SETUP

Whenever testing an article against certain conditions, there are limitations either due to

1. Available space and control to place required TCP (temperature controlled panels),
2. Limited access to certain locations on test hardware
3. Components with wide range of test temperature, located in proximity of each other, will limit testing
4. Test facility limitations

Lesson learned #3

Perform analysis ahead of time to verify the effects of test limitations. Make systems team aware of the limitations that will prevent testing for some of the hardware.

THERMAL MODEL CORRELATION

A model correlation consists of compiling test data, for ease of model correlation, and a changing model that converges, through iteration, to a solution within allowable temperature and heater power requirements. It is best practice to insist, to the project, on conducting the balance as early as possible during thermal testing. This will allow the thermal analyst to gain understanding of whether the test article is behaving as predicted through analysis.

After conversation with multiple thermal analyst, it was learned that following steps are crucial part of model correlation:

Pre-Test:

1. Set up a workbook (Excel) that is ready to accept the raw **temperature, heater power** and **power dissipation** data
2. Filter through the most critical temperature sensors. These are usually at the interface of electronic boxes and thermally sensitivity components.

During Testing:

1. Record temperature data before starting to pump down to vacuum. This will provide reference on which sensors are different relative to ambient temperature.
2. Notify personnel on shift to take notes of each incident: for example, when components are powered on and any “out of the ordinary events”

Model Correlation:

1. Verify the final test setup matches the model
2. Update power dissipation values for all boxes that have heat dissipation
3. Replace all heaters with heat loads and apply time-average heater values
4. Apply time-average, test derived, heat loads to heater panels that simulate the environment.
5. Start with changing the effective emmissivity of blankets
6. If the temperatures are out of order by large amount (~10C) then verify that the geometry is consistent between model and reality

At the beginning of model correlation, hot balance test data should be analyzed first. The hot case will provide the least amount of heat flow variation due to heater cycling. Currently the ATLAS thermal model is still being analyzed for model correlation.

CONCLUSION

The final test setup as shown in Figure 6.

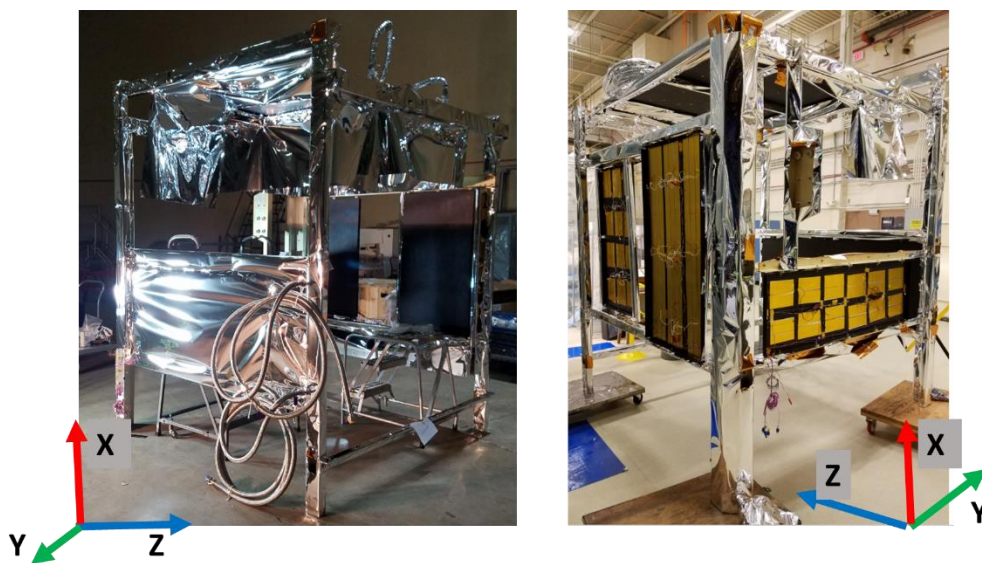

Figure 6: ATLAS TVac Test Cage

ATLAS thermal balance test did conclude with 80% of the temperature sensors to be within requirement. Due to test setup limitations, many of the components did not achieve qualification temperatures but were waived due to robust component level thermal testing.

Overall, all of the thermal requirements were met, with the exception of four thermal cycles on the instrument. Due to the laser issues, there was an unplanned chamber break. Once the instrument has been re-patched, the final two thermal cycles along with minimum of two thermal balance will be conducted again.

In conclusion, when preparing for thermal balance and thermal vacuum testing it is critical to understand requirements and limitations. Afterwards, review the decisions with systems team and verify with more experienced thermal analysts on anything that can be streamlined to make the model correlation process and thermal testing an ease at the same time gain all the required understanding of the test article.

REFERENCES

¹ Waleed Abdalati, H. Jay Zwally, Robert Bindschadler, Bea Csatho, Sinead Louise Farrell, Helen Amanda Fricker, David Harding, Ronald Kwok, Michael Lefsky, Thorsten Markus, Alexander Marshak, Thomas Neumann, Stephen Palm, Bob Schutz, Ben Smith, James Spinhirne, and Charles Webb, "The ICESat-2 Laser Altimetry Mission", Proceedings of the IEEE, Vol. 98, No. 5, pp. 735-751, May 201

ACKNOWLEDGMENTS

In order to complete this paper, much of the data was extracted from the works of ATLAS TVac Test Report written by Matthew Garrison of Goddard Space Flight Center Thermal Engineering Branch.