

LMSC/D974197B
31 MAY 1985

**SPACE TELESCOPE
SYSTEMS DESCRIPTION HANDBOOK**

ST/SE-02

**SYSTEMS ENGINEERING
SPACE TELESCOPE PROJECT**

**SUBMITTED IN ACCORDANCE WITH REQUIREMENTS OF
CONTRACT NAS 8-32697, DPD 539**



LOCKHEED MISSILES & SPACE COMPANY, INC.
SPACE SYSTEMS DIVISION • SUNNYVALE, CALIFORNIA

FOREWORD

The Space Telescope Systems Description Handbook is submitted by Lockheed Missiles & Space Company, Inc., in accordance with DR SE-02 of NASA-MSFC NAS8-32697.

The Space Telescope Systems Description Handbook provides general background information about the Space Telescope and describes the telescope's systems and subsystems. This handbook has been extensively reviewed by all responsible agencies and associates and therefore is considered correct as of this date.

Questions or comments regarding this document may be directed to Robert E. Carter, (205) 453-0983.

Approved by:

Prepared by:



D. A. Gervin, Manager
Systems Analysis and Operations
Space Telescope

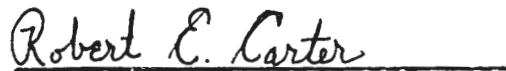

R. E. Carter
LMSC Resident Representative
Marshall Space Flight Center



D. J. Tenerelli, CSE
Operations, Integration & Systems Analysis
Space Telescope



B. R. Bulkin
Program Manager
Space Telescope

RELEASE
DATE:

DOCUMENT CHANGE RECORD

SHEET: ii

| CHANGE DOCUMENT: LMSC/D974197B | | B | 31 May 1985 | COPY NO. |
|--------------------------------|---|------------------|---|----------|
| | | NUMBERED | REVISION | DATED |
| CHANGE (DATE) | TO INCORPORATE THE CHANGE INTO THE DOCUMENT: | | OTHER COMMENTS REGARDING THIS CHANGE (AUTH., INSTRUCT., ET.) | |
| | 1. ADD PAGES; | 2. REMOVE PAGES; | | |
| Initial Issue 6-15-84 | Initial issue covering only the SSM section and proposed outline. | | | |
| A | Coordination copy | dated 11/30/84. | Never published. | |
| B 5-31-85 | 273 Printed Pages | N/A | Supersedes initial issue in entirety. | |
| | | | | |

TABLE of CONTENTS

| Section | Title | Page |
|---------|---|------|
| | FOREWORD | i |
| | DOCUMENT CHANGE RECORD | ii |
| | TABLE of CONTENTS | iii |
| | LIST of FIGURES | x |
| | LIST of TABLES | xii |
| | ACRONYMS/ABBREVIATIONS | xiii |
| 1.0 | INTRODUCTION | 1-1 |
| 1.1 | Purpose | 1-1 |
| 1.2 | Scope | 1-1 |
| 1.3 | Preface | 1-1 |
| 1.3.1 | Why Space Telescope? | 1-2 |
| 1.3.2 | Specific Scientific Objectives | 1-3 |
| 2.0 | OVERVIEW | 2-1 |
| 2.1 | General Configuration | 2-1 |
| 2.1.1 | External Structure | 2-1 |
| 2.1.2 | Support Systems | 2-4 |
| 2.1.3 | Coordinate Systems | 2-5 |
| 2.2 | ST Major Elements | 2-7 |
| 2.2.1 | Support Systems Module (SSM) | 2-7 |
| 2.2.2 | Optical Telescope Assembly (OTA) | 2-8 |
| 2.2.3 | Scientific Instruments (SIs) | 2-9 |
| 2.2.4 | SI Control and Data Handling (SI C&DH) | 2-10 |
| 2.2.5 | Solar Arrays (SAs) | 2-11 |
| 2.3 | Mission Operation Ground System (MOGS) | 2-12 |
| 2.4 | Space Support Equipment (SSE) | 2-14 |
| 2.5 | Management Responsibility | 2-14 |
| 2.5.1 | NASA Centers | 2-15 |
| 2.5.1.1 | Office of Space Science (OSS) | 2-15 |
| 2.5.1.2 | Marshall Space Flight Center (MSFC) | 2-15 |
| 2.5.1.3 | Goddard Space Flight Center (GSFC) | 2-15 |
| 2.5.1.4 | Office of Space Tracking and Data Systems (OSTDS) | 2-16 |
| 2.5.1.5 | Johnson Space Center (JSC) | 2-16 |
| 2.5.1.6 | Kennedy Space Center (KSC) | 2-16 |
| 2.5.2 | Associate Contractors and Agency | 2-16 |
| 2.5.2.1 | Lockheed Missiles & Space Company, Inc. | 2-16 |
| 2.5.2.2 | Perkin-Elmer | 2-16 |
| 2.5.2.3 | European Space Agency | 2-16 |
| 2.5.3 | Major ST Project Elements | 2-17 |
| 2.5.3.1 | Scientific Instruments (SIs) | 2-17 |
| 2.5.3.2 | Other Space Telescope Equipment | 2-17 |

TABLE of CONTENTS
(Continued)

LMSC/D974197 B
31 May 1985

| Section | Title | Page |
|---------|---|------|
| 3.0 | SUPPORT SYSTEMS MODULE (SSM) | 3-1 |
| 3.1 | Structures and Mechanisms (S&M) Subsystem | 3-2 |
| 3.1.1 | Aperture Door (AD) | 3-3 |
| 3.1.2 | Light Shield (LS) | 3-4 |
| 3.1.3 | Forward Shell (FS) | 3-5 |
| 3.1.4 | Equipment Section (ES) | 3-6 |
| 3.1.5 | Aft Shroud (AS) | 3-8 |
| 3.1.6 | Aft Bulkhead (AB)..... | 3-9 |
| 3.1.7 | Mechanisms | 3-10 |
| 3.1.7.1 | Latch | 3-11 |
| 3.1.7.2 | Hinge Drive | 3-12 |
| 3.1.7.3 | Rotary Drive Actuator (RDA) | 3-13 |
| 3.1.7.4 | Two-Axis Gimbal (TAG) | 3-14 |
| 3.1.8 | Solar Array (SA) Latch Mechanisms | 3-15 |
| 3.1.9 | High Gain Antenna (HGA) Mechanisms | 3-16 |
| 3.1.10 | Aperture Door (AD) Mechanisms | 3-17 |
| 3.2 | Instrumentation and Communication (I&C) Subsystem | 3-18 |
| 3.2.1 | Low Gain Antenna (LGA) | 3-19 |
| 3.2.2 | High Gain Antenna (HGA) | 3-19 |
| 3.2.3 | Multiple Access (MA) | 3-20 |
| 3.2.4 | S-Band Single Access (SSA) | 3-20 |
| 3.3 | Data Management Subsystem (DMS) | 3-21 |
| 3.3.1 | DF-224 Computer | 3-24 |
| 3.3.1.1 | Central Processing Unit (CPU) | 3-25 |
| 3.3.1.2 | Memory Unit (MU) | 3-25 |
| 3.3.1.3 | Input/Output Unit (IOU) | 3-25 |
| 3.3.1.4 | Internal Data Bus (IDB) | 3-25 |
| 3.3.1.5 | External Data Bus (EDB) | 3-25 |
| 3.3.1.6 | Power Control Unit (PCU) | 3-25 |
| 3.3.2 | Data Management Unit (DMU) | 3-26 |
| 3.3.2.1 | Timing | 3-28 |
| 3.3.2.2 | Engineering Data (ED) Handling | 3-28 |
| 3.3.2.3 | Science Data (SD) Handling | 3-28 |
| 3.3.2.4 | Telemetry Data Handling | 3-29 |
| 3.3.2.5 | Forward Link Commands | 3-29 |
| 3.3.3 | Data Interface Unit (DIU) | 3-30 |
| 3.3.3.1 | Electrical/Thermal Characteristics | 3-30 |
| 3.3.3.2 | Command and Data Handling Characteristics | 3-31 |
| 3.3.4 | Engineering/Science Tape Recorder (ESTR) | 3-32 |
| 3.3.5 | Oven-Controlled Crystal Oscillator (OCXO) | 3-34 |
| 3.4 | Pointing Control Subsystem (PCS) | 3-35 |
| 3.4.1 | PCS Hardware Description | 3-35 |
| 3.4.1.1 | Fine Guidance Sensor (FGS) | 3-38 |
| 3.4.1.2 | Fixed Head Star Tracker (FHST) | 3-39 |
| 3.4.1.3 | Coarse Sun Sensor (CSS) | 3-40 |
| 3.4.1.4 | Magnetic Sensing System (MSS) | 3-41 |
| 3.4.1.5 | Rate Gyro Assembly (RGA) | 3-42 |
| 3.4.1.6 | Computer | 3-43 |
| 3.4.1.7 | Pointing and Safemode Electronics Assembly (PSEA) | 3-44 |
| 3.4.1.8 | Reaction Wheel Assembly (RWA) | 3-45 |
| 3.4.1.9 | Magnetic Torquing System (MTS) | 3-46 |

TABLE of CONTENTS
(Continued)

LMSC/D974197B
31 May 1985

| Paragraph | Title | Page |
|-----------|---|------|
| 3.4.1.10 | Retrieval Mode Gyro Assembly (RMGA) | 3-47 |
| 3.4.2 | PCS Functions | 3-48 |
| 3.4.3 | Operational Modes | 3-50 |
| 3.4.3.1 | Deployment Mode | 3-50 |
| 3.4.3.2 | Systems Calibration | 3-50 |
| 3.4.3.3 | Attitude Determination | 3-51 |
| 3.4.3.4 | Attitude Update | 3-51 |
| 3.4.3.5 | Maneuvers | 3-51 |
| 3.4.3.6 | FGS Guide Star Acquisition | 3-52 |
| 3.4.3.7 | Fine Pointing Mode | 3-52 |
| 3.5 | Electrical Power Subsystem (EPS) | 3-53 |
| 3.5.1 | Solar Array (SA) | 3-55 |
| 3.5.1.1 | Solar Array Drive Electronics (SADE) | 3-56 |
| 3.5.1.2 | Deployment Control Electronics (DCE) | 3-56 |
| 3.5.2 | Batteries | 3-59 |
| 3.5.2.1 | Battery Protection and Reconditioning Circuit ... | 3-61 |
| 3.5.2.2 | Input Circuit Assembly | 3-62 |
| 3.5.2.3 | Battery Case Extension | 3-62 |
| 3.5.3 | Charge Current Controllers (CCC) | 3-63 |
| 3.5.4 | Power Control Unit (PCU) | 3-64 |
| 3.5.5 | Power Distribution Unit (PDU) | 3-64 |
| 3.6 | Thermal Control Subsystem (TCS) | 3-65 |
| 3.7 | Safing System (SS) | 3-69 |
| 3.7.1 | ST Safing System (STSS) | 3-69 |
| 3.7.1.1 | Mode Progression and Sequence | 3-70 |
| 3.7.1.2 | Mode Description | 3-71 |
| 3.7.2 | Pointing and Safemode Electronics Assembly (PSEA) | 3-73 |
| 4.0 | OPTICAL TELESCOPE ASSEMBLY (OTA) | 4-1 |
| 4.1 | Primary Mirror Assembly (PMA) | 4-4 |
| 4.1.1 | Main Ring (MR) | 4-5 |
| 4.1.2 | Reaction Plate Assembly (RPA) | 4-6 |
| 4.1.3 | Primary Mirror Assembly Baffles | 4-6 |
| 4.1.3.1 | Main Baffle Assembly (MBA) | 4-7 |
| 4.1.3.2 | Central Baffle Assembly (CBA) | 4-7 |
| 4.1.4 | Primary Mirror (PM) | 4-8 |
| 4.2 | Secondary Mirror Assembly (SMA) | 4-9 |
| 4.2.1 | Secondary Mirror Subassembly (SMSA) | 4-9 |
| 4.2.2 | Secondary Baffle Assembly (SBA) | 4-10 |
| 4.2.3 | Metering Truss Structure | 4-11 |
| 4.3 | Focal Plane Structure Assembly (FPSA) | 4-12 |
| 4.3.1 | Focal Plane Deck Assembly (FPDA) | 4-13 |
| 4.3.2 | Scientific Instrument Support Structure (SISS) .. | 4-13 |
| 4.3.3 | Mounting Constraints | 4-13 |
| 4.3.4 | SSM-Equipment Shelf (SSM-ES) | 4-15 |

TABLE of CONTENTS
(Continued)

LMSC/D974197B
31 May 1985

| Section | Title | Page |
|---------|--|------|
| 4.4 | Fine Guidance Sensor (FGS) | 4-16 |
| 4.5 | OTA Equipment Section (OTA ES) | 4-21 |
| 4.5.1 | Electrical Power Thermal Control Electronics | 4-21 |
| 4.5.2 | Data Interface Unit (DIU) | 4-21 |
| 4.5.3 | Actuator Control Electronics (ACE) | 4-23 |
| 4.5.4 | Optical Control Electronics (OCE) | 4-23 |
| 4.5.5 | Actuators | 4-23 |
| 4.5.6 | Fine Guidance Electronics (FGE) | 4-23 |
| 5.0 | SCIENTIFIC INSTRUMENTS (SIs) | 5-1 |
| 5.1 | Wide Field/Planetary Camera (WF/PC) | 5-5 |
| 5.2 | Faint Object Camera (FOC) | 5-8 |
| 5.2.1 | Optical Bench | 5-12 |
| 5.2.2 | Load Carrying Structure Assembly | 5-12 |
| 5.2.3 | Electronic Bay Assembly (EBA) | 5-12 |
| 5.3 | High Resolution Spectrograph (HRS) | 5-14 |
| 5.4 | Faint Object Spectrograph (FOS) | 5-18 |
| 5.5 | High Speed Photometer (HSP) | 5-22 |
| 5.6 | Astrometry with the Fine Guidance System (FGS) .. | 5-25 |
| 5.6.1 | Fixed Field | 5-27 |
| 5.6.2 | Moving Targets | 5-27 |
| 5.6.3 | Intensity Transfer | 5-27 |
| 6.0 | SI CONTROL and DATA HANDLING (SI C&DH) | 6-1 |
| 6.1 | SI C&DH Electronic Components | 6-2 |
| 6.1.1 | NASA Standard Spacecraft Computer Model-I (NSSC-I) | 6-2 |
| 6.1.2 | Standard Interface for Computer (STINT) | 6-2 |
| 6.1.3 | Control Unit/Science Data Formatter (CU/SDF) | 6-3 |
| 6.1.4 | Power Control Unit (PCU) | 6-4 |
| 6.1.5 | Remote Module (RM) | 6-4 |
| 6.1.6 | Bus Coupler Unit (BCU) | 6-4 |
| 6.1.7 | Multiplexed Data Bus (MDB) | 6-4 |
| 6.2 | SI C&DH Component Function | 6-5 |
| 6.2.1 | Command Handling | 6-5 |
| 6.2.2 | Processor Interface Table (PIT) Handling | 6-8 |
| 6.2.3 | Timing and Synchronization | 6-9 |
| 6.2.4 | Engineering Data (ED) Handling | 6-11 |
| 6.2.5 | Science Data (SD) Handling | 6-13 |

TABLE of CONTENTS
(Continued)

LMSC/D974197B
31 May 1985

| Paragraph | Title | Page |
|-----------|--|------|
| 7.0 | SOLAR ARRAY (SA) | 7-1 |
| 7.1 | SA Configuration | 7-1 |
| 7.1.1 | Electrical Power Subsystem (EPS) | 7-2 |
| 7.1.2 | Summary Weights and Mass Properties | 7-2 |
| 7.1.3 | SA Description | 7-3 |
| 7.1.3.1 | Stowed Configuration | 7-3 |
| 7.1.3.2 | Deployed Configuration | 7-4 |
| 7.2 | SA Subsystems | 7-5 |
| 7.2.1 | Solar Cell Array | 7-5 |
| 7.2.2 | Primary Deployment Mechanism (PDM) | 7-5 |
| 7.2.3 | Solar Array Drive (SAD) Adapter | 7-6 |
| 7.2.4 | Secondary Deployment Mechanism (SDM) | 7-7 |
| 7.2.5 | Solar Array Drive Mechanism (SADM) | 7-8 |
| 7.2.6 | Electronic Control Assembly (ECA) | 7-9 |
| 7.2.6.1 | Deployment Control Electronics (DCE) | 7-10 |
| 7.2.6.2 | Solar Array Drive Electronics (SADE) | 7-10 |
| 7.2.7 | Diode Box Assembly (DBA) | 7-11 |
| 7.3 | SA Equipment List | 7-12 |
| 7.4 | Interface Description | 7-12 |
| 8.0 | MISSION OPERATIONS GROUND SYSTEM (MOGS) | 8-1 |
| 8.1 | ST Operations Control Center (STOCC) | 8-1 |
| 8.1.1 | Payload Operations Control Center (POCC) | 8-1 |
| 8.1.2 | Science Support Center (SSC) | 8-2 |
| 8.1.3 | Data Capture Facility (DCF) | 8-2 |
| 8.1.4 | ST Science Institute (ST Sci) | 8-2 |
| 8.2 | Support Elements | 8-4 |
| 8.2.1 | Spaceflight Tracking and Data Network (STDN) | 8-4 |
| 8.2.1.1 | Tracking and Data Relay Satellite System (TDRSS) . | 8-4 |
| 8.2.1.2 | Ground Spaceflight Tracking & Data Network (GSTDN) | 8-5 |
| 8.2.1.3 | NASA Communications Network (NASCOM) | 8-6 |
| 8.2.1.4 | Network Control Center (NCC) | 8-6 |
| 8.2.2 | Mission Planning Terminal (MPT) | 8-7 |
| 8.2.2.1 | Interactive POCC Capability | 8-7 |
| 8.2.2.2 | NASCOM Interface | 8-8 |
| 8.2.2.3 | NCC Interface Protocol | 8-8 |
| 8.2.2.4 | Schedule Requests, Confirmations and Receipt | 8-8 |
| 8.2.2.5 | Prototype Event Definition | 8-8 |
| 8.2.2.6 | Configuration Code Definition | 8-8 |
| 8.2.2.7 | Support Impact Message | 8-9 |
| 8.2.2.8 | POCC Information Display | 8-9 |
| 8.2.2.9 | Data Base Exchange/Access | 8-9 |
| 8.2.2.10 | Other MPT Functions | 8-9 |
| 8.2.3 | Operation Support Computing Facility (OSCF) | 8-9 |
| 8.2.3.1 | Metric Data Processing | 8-10 |
| 8.2.3.2 | Orbit Determination | 8-11 |
| 8.2.3.3 | Acquisition Data Generation | 8-11 |
| 8.2.3.4 | Scheduling/Mission Planning Data Generation | 8-11 |

TABLE of CONTENTS
(Continued)

LMSC/D974197 B
31 May 1985

| Paragraph | Title | Page |
|-----------|---|------|
| 9.0 | ST ORBITAL MAINTENANCE | 9-1 |
| 9.1 | Maintenance Mission (MM) | 9-1 |
| 9.1.1 | Berthed Position | 9-1 |
| 9.1.2 | Maintenance Position | 9-1 |
| 9.1.3 | Reboost Position | 9-1 |
| 9.2 | Space Support Equipment (SSE) | 9-2 |
| 9.2.1 | Maintenance Platform (MP) Design Features | 9-3 |
| 9.2.1.1 | Cradle | 9-3 |
| 9.2.1.2 | Pivot Arm | 9-4 |
| 9.2.1.3 | Rotation Platform | 9-4 |
| 9.2.1.4 | Umbilicals | 9-4 |
| 9.2.2 | ORU Carrier Design Features | 9-5 |
| 9.2.2.1 | ORU Payload Complements | 9-6 |
| 9.2.2.2 | ORU Carrier/Orbiter Interface | 9-7 |
| 9.2.2.3 | Carrier Crew Aids | 9-7 |
| 9.3 | ST Hardware Design Features | 9-7 |
| 9.3.1 | Orbital Replaceable Units (ORU) | 9-7 |
| 9.3.2 | ST Mounted Crew Aids | 9-9 |
| 9.3.2.1 | Handrails | 9-9 |
| 9.3.2.2 | Foot Restraint Sockets | 9-9 |
| 9.3.2.3 | Astronaut Control Panel (ACP) | 9-9 |
| 9.4 | Orbiter Stored Crew Aids and Tools | 9-10 |
| 9.4.1 | Portable Handholds | 9-10 |
| 9.4.2 | Foot Restraint | 9-10 |
| 9.4.3 | Personnel and Equipment Tethers | 9-10 |
| 9.4.4 | Ratchet Wrench | 9-10 |
| 9.4.5 | Box End Ratchet | 9-11 |
| 9.4.6 | Portable Grapple Fixture | 9-11 |
| 9.4.7 | Appendage Jettison Handle | 9-11 |
| 9.4.8 | EVA Portable Lights | 9-11 |
| 9.5 | Protective Covers | 9-11 |

TABLE of CONTENTS
(Concluded)

LMSC/D974197 B
31 May 1985

| Appendix | Title | Page |
|----------|---|------|
| A | SUMMARY of WEIGHTS and MASS PROPERTIES | A-1 |
| 1.0 | INTRODUCTION | A-1 |
| | 1-1 Specification Weight Status | A-3 |
| | 1-2 Orbiter Payload Control Weights | A-4 |
| | 1-3 Space Support Equipment (SSE) | A-5 |
| | 1-4 First Planned Maintenance Mission | A-6 |
| 2.0 | SUMMARY WEIGHT STATEMENT | A-7 |
| 3.0 | DETAILED WEIGHT STATEMENT | A-8 |
| 3.1 | Support Systems Module (SSM) | A-8 |
| | Aperture Door | A-8 |
| | Light Shield | A-8 |
| | Forward Shell | A-8 |
| | OTA Equipment Section | A-9 |
| | SSM Equipment Section | A-9 |
| | Aft Shroud | A-10 |
| | Total Structure | A-10 |
| | Mechanisms | A-11 |
| | Thermal Control | A-11 |
| | Electrical Power | A-11 |
| | Communication and Instrumentation | A-12 |
| | Data Management | A-13 |
| | Pointing Control | A-13 |
| | Crew Systems | A-13 |
| 3.2 | Optical Telescope Assembly (OTA) | A-14 |
| 3.3 | Solar Array (SA) | A-14 |
| 3.4 | Faint Object Camera (FOC) | A-15 |
| 3.5 | Faint Object Spectrograph (FOS) | A-15 |
| 3.6 | High Resolution Spectrometer (HRS) | A-15 |
| 3.7 | High Speed Photometer (HSP) | A-15 |
| 3.8 | Wide Field/Planetary Camera (WF/PC) | A-15 |
| 3.9 | Scientific Instruments C&DH (SI C&DH) | A-15 |
| 3.10 | Total Space Telescope Current Weight | A-16 |
| 4.0 | ST MASS PROPERTIES | A-17 |
| 5.0 | CRITICAL MASS PROPERTIES SUMMARY | A-19 |
| 5.1 | Mass Properties Compatibility with PCS Capability | A-19 |
| 5.2 | Orbiter Payload C.G. Limits | A-20 |
| 6.0 | PENDING and POTENTIAL CHANGES | A-21 |
| 6.1 | SSM | A-21 |
| 6.2 | OTA | A-21 |
| 6.3 | HRS | A-21 |
| 7.0 | REFERENCES - ST MASS PROPERTIES | A-22 |
| B | DOCUMENT TREES | B-1 |
| C | ST SSM SCHEMATICS - TABLE of CONTENTS (SE-08) ... | C-1 |
| D | SPACE TELESCOPE CONFIGURATION DRAWINGS | D-1 |

LIST of FIGURES

| Figure | Title | Page |
|--------|--|------|
| 2-1 | Hubble Space Telescope | 2-2 |
| 2-2 | Space Telescope Exploded View | 2-3 |
| 2-3 | Orbiter/ST Coordinate Relationships | 2-6 |
| 2-4 | Support System Module - Design Features | 2-7 |
| 2-5 | Optical Telescope Assembly - Design Features | 2-8 |
| 2-6 | Scientific Instruments | 2-9 |
| 2-7 | Scientific Instruments Control and Data Handling . | 2-10 |
| 2-8 | Space Telescope with Solar Arrays | 2-11 |
| 2-9 | Mission Operation Ground System | 2-12 |
| 2-10 | Space Telescope Communication Network | 2-13 |
| | | |
| 3-1 | ST Support Systems Module Design Features | 3-1 |
| 3-2 | ST Inboard/Outboard Profile | 3-2 |
| 3-3 | Mechanisms located on ST | 3-2 |
| 3-4 | Aperture Door | 3-3 |
| 3-5 | Light Shield | 3-4 |
| 3-6 | Forward Shell | 3-5 |
| 3-7 | SSM Equipment Section | 3-6 |
| 3-8 | Equipment Section Component Locations | 3-7 |
| 3-9 | Aft Shroud | 3-8 |
| 3-10 | Aft Bulkhead | 3-9 |
| 3-11 | Mechanisms Block Diagram | 3-10 |
| 3-12 | Latch Assembly | 3-11 |
| 3-13 | Typical Hinge Assembly | 3-12 |
| 3-14 | Rotary Drive Actuator | 3-13 |
| 3-15 | Two Axis Gimbal (TAG) | 3-14 |
| 3-16 | Solar Array Latch Mechanisms | 3-15 |
| 3-17 | High Gain Antenna Mechanisms | 3-16 |
| 3-18 | Aperture Door Mechanisms | 3-17 |
| 3-19 | I&C Subsystem Block Diagram | 3-18 |
| 3-20 | High Gain Antenna | 3-19 |
| 3-21 | Data Management Functional Block Diagram | 3-22 |
| 3-22 | SSM Equipment Section DMS Component Locations ... | 3-23 |
| 3-23 | DF-224 Computer | 3-24 |
| 3-24 | DMU Block Diagram | 3-26 |
| 3-25 | Data Management Unit Assembly | 3-27 |
| 3-26 | Internal Assembly of ESTR | 3-32 |
| 3-27 | Functional Block Diagram of ESTR | 3-33 |
| 3-28 | Oven-Controlled Crystall Oscillator | 3-34 |
| 3-29 | PCS Functional Diagram | 3-36 |
| 3-30 | PCS Equipment Locations | 3-37 |
| 3-31 | Location of Fine Guidance Sensors | 3-38 |
| 3-32 | Fixed Head Star Tracker Locations on ST | 3-39 |
| 3-33 | Coarse Sun Sensor Locations and Field of View ... | 3-40 |
| 3-34 | MSS Location and Alignment | 3-41 |
| 3-35 | Rate Gyro Assembly | 3-42 |
| 3-36 | Reaction Wheel Assembly Physical Characteristics . | 3-45 |
| 3-37 | RWA Position Detailed View | 3-45 |
| 3-38 | Magnetic Torquer Location | 3-46 |
| 3-39 | Electrical Power Subsystem Block Diagram | 3-53 |
| 3-40 | EPS Equipment Location in ST Equipment Section ... | 3-54 |
| 3-41 | Solar Array Arrangement | 3-55 |
| 3-42 | DCE Block and Interconnect Diagram | 3-57 |

LIST of FIGURES
(Continued)

LMSC/D974197 B
31 May 1985

| Figure | Title | Page |
|--------|---|------|
| 3-43 | ST SA-DCE Signal Conditioner Block Diagram | 3-58 |
| 3-44 | Nickel-Cadmium RSN 55-3 Cell | 3-59 |
| 3-45 | BPRC Block Diagram | 3-61 |
| 3-46 | Charge Current Controller | 3-63 |
| 3-47 | SSM Baseline Thermal Design | 3-66 |
| 3-48 | Safemode Description, Progression, and Sequence . | 3-70 |
| 3-49 | Pointing and Safemode Electronics Assembly | 3-73 |
| 4-1 | OTA Exploded View | 4-1 |
| 4-2 | OTA Major Structural Components | 4-2 |
| 4-3 | Space Telescope Incoming Light Path | 4-3 |
| 4-4 | Primary Mirror Assembly | 4-4 |
| 4-5 | Primary Mirror Assembly Cross Section | 4-5 |
| 4-6 | Reaction Plate Assembly | 4-6 |
| 4-7 | Main Baffle Assembly | 4-7 |
| 4-8 | Central Baffle Assembly | 4-7 |
| 4-9 | Primary Mirror Construction | 4-8 |
| 4-10 | Secondary Mirror Assembly | 4-9 |
| 4-11 | Secondary Mirror Subassembly | 4-9 |
| 4-12 | Secondary Mirror Subassembly and Baffles | 4-10 |
| 4-13 | Metering Truss | 4-11 |
| 4-14 | Focal Plane Structure Assembly | 4-12 |
| 4-15 | Radial Bay Mounting Arrangement and Constraints . | 4-14 |
| 4-16 | Axial SI Mounting Arrangement and Constraints ... | 4-14 |
| 4-17 | SSM-Equipment Shelf | 4-15 |
| 4-18 | SSM-Equipment Shelf Mount Constraints | 4-15 |
| 4-19 | FGS Optical and Mechanical Arrangement | 4-16 |
| 4-20 | Fine Guidance Sensor Optical Schematic | 4-16 |
| 4-21 | Space Telescope Focal Plane | 4-17 |
| 4-22 | FGS Field of View Description | 4-18 |
| 4-23 | Interferometer Optical Assemblies | 4-18 |
| 4-24 | Koesters Interferometer Dead Center Tracking | 4-19 |
| 4-25 | Koesters Interferometer Off-Axis Case | 4-20 |
| 4-26 | OTA Equipment Section | 4-22 |
| 5-1 | Location of Scientific Instruments | 5-1 |
| 5-2 | Spectral Ranges of the SIs and the OTA | 5-2 |
| 5-3 | Atmospheric Absorption Spectral Range | 5-4 |
| 5-4 | Wide Field/Planetary Camera | 5-5 |
| 5-5 | Faint Object Camera | 5-8 |
| 5-6 | High Resolution Spectrograph | 5-14 |
| 5-7 | Faint Object Spectrograph | 5-18 |
| 5-8 | High Speed Photometer | 5-22 |
| 6-1 | SI Control and Data Handling | 6-2 |
| 6-2 | Command Information Flow | 6-6 |
| 6-3 | PIT Information Flow | 6-8 |
| 6-4 | Timing and Synchronization Information Flow | 6-10 |
| 6-5 | Engineering Data Information Flow | 6-12 |
| 6-6 | Science Data Information Flow | 6-14 |
| 7-1 | SA Secondary Deployment Mechanism | 7-1 |
| 7-2 | Solar Array in Stowed Configuration | 7-3 |
| 7-3 | Solar Array in Deployed Configuration | 7-4 |

LIST of FIGURES
(Concluded)

LMSC/D974197 B
31 May 1985

| Figure | Title | Page |
|--------|--|------|
| 8-1 | Mission Operations Ground System | 8-1 |
| 9-1 | Maintenance Mission SSE Flight Configuration | 9-2 |
| 9-2 | SSE Maintenance Platform (Modified FSS) | 9-3 |
| 9-3 | SSE ORU Carrier - 1 FGS Configuration | 9-5 |
| 9-4 | SSE Payload Complements | 9-6 |

LIST OF TABLES

| Table | Title | Page |
|-------|--|------|
| 5-1 | Wide Field/Planetary Camera Performance | 5-7 |
| 5-2 | Faint Object Camera Performance | 5-12 |
| 5-3 | High Resolution Spectrograph Performance | 5-18 |
| 5-4 | Faint Object Spectrograph Performance | 5-22 |
| 5-5 | High Speed Photometer Performance | 5-25 |
| 5-6 | Astrometry with the Fine Guidance Sensor | 5-28 |
| 8-1 | ST In-Track Orbital Position Prediction Accuracy | 8-11 |
| 9-1 | Orbital Replaceable Units Listing | 9-8 |

ACRONYMS/ABBREVIATIONS

| | |
|--------|--|
| A | Ampere |
| A | Angstrom (10 ^{**} -10 m), see notation ** |
| AB | Aft Bulkhead |
| ac | Alternating Current |
| ACE | Actuator Control Electronics |
| ACP | Astronaut Control Panel |
| ACS | Actuator Control Subsystem |
| AD | Aperture Door |
| AFD | Aft Flight Deck |
| Al | Aluminum |
| AOS | Acquisition of Signal |
| AS | Aft Shroud |
| ASSY | Assembly |
| BAe | British Aerospace |
| BASD | Ball Aerospace Systems Division |
| BCU | Bus Coupler Unit |
| BOT | Beginning of Tape |
| BPI | Bits per Inch |
| C | Celsius |
| C&DH | Communication and Data Handling |
| C-WEAR | Critical-Work Element Audit Review |
| C/C | Configuration Control |
| CBA | Central Baffle Assembly |
| CCC | Charge Current Controller |
| CCD | Charge-Coupled Device |
| CDI | Command Data Interface |
| CEHT | Camera Electrical High Tension |
| CEI | Contract End Item |
| CEU | Camera Electronics Unit |
| CG | Center of Gravity |
| CIT | California Institute of Technology |
| CM | Camera Module Configuration Management |
| CMD | Command |
| cm | Centimeter |
| CORU | Canidate Orbital Replaceable Unit |
| CPC | Computer Program Command |
| CPM | Central Processor Module |
| CPU | Central Processing Unit |
| CRT | Cathode Ray Tube |
| CsI | Cesium Iodide |
| CsTe | Cesium Tellurium |
| CSS | Coarse Sun Sensor |
| CU | Control Unit |
| CU/SDF | Control Unit/Science Data Formatter |
| DBA | Diode Box Assembly |
| dc | Direct Current |
| DCE | Deployment Ccntrol Electronics |
| DCF | Data Capture Facility |
| DDC | Digital Data Control |
| Deg | Degree |
| DH | Data Handling |

ACRONYMS/ABBREVIATIONS
(Continued)

LMSC/D974197 B
31 May 1985

DHU Detector Head Unit
DICU Data Handling Interface and Control Unit
DIU Data Interface Unit
DMA Direct Memory Access
DM&O Data Management and Operations
DMS Data Management Subsystem
DMU Data Management Unit
DR Data Requirements
DSASS Digital Sun Angle Sensing System

EBA Electronics Bay Assembly
EBS Electron Bombarded Silicon
ECA Electronics Control Assembly
ECP Engineering Change Proposal
ECU Electronics Control Unit
ED Engineering Data
EDB External Data Bus
EHT Electrical High Tension
EMI Electromagnetic Interference
EMU Extravehicular Mobility Unit
EOT End of Tape
EP Electrical Power
EPS Electrical Power Subsystem
EPTCE Electrical Power Thermal Control Electronics
ES Equipment Section, Equipment Shelf
ESA European Space Agency
ESTR Engineering and Science Tape Recorder
EU Expander Unit
EV Extravehicular
EVA Extravehicular Activity

F Fahrenheit
FCA Figure Control Actuator
FGE Fine Guidance Electronics
FGS Fine Guidance Sensor
FHST Fixed Head Star Tracker
FOC Faint Object Camera
FOS Faint Object Spectrograph
FOSR Flexible Optical Solar Reflector
FOV Field of View
FPA Focal Plane Assembly
FPDA Focal Plane Deck Assembly
FPS Fine Pointing Simulation, Focal Plane Structure
FPSA Focal Plane Structure Assembly
FS Forward Shell
FSS Flight Support Structure
Flight Support System (A' cradle not modified for SSE)
FWH Flexible Wire Harness

G/E Graphite-Epoxy
GE General Electric
GEA Gimbal Electronics Assembly
GFE Government Furnished Equipment
GGM Gravity Gradient Mode
GSE Ground Support Equipment
GSFC Goddard Space Flight Center (Maryland)
GSTDN Ground Spaceflight Tracking and Data network

ACRONYMS/ABBREVIATIONS
(Continued)

LMSC/D974197 B
31 May 1985

HGA High Gain Antenna
HgF2 Mercury Difluoride
HGAS High Gain Antenna System
HLD High Level Discrete
HRS High Resolution Spectrograph
HSP High Speed Photometer
HST Hubble Space Telescope (commonly referred to as ST)
Hz Hertz (Cycles per Second)

I Invar
I&C Instrumentation and Communications (subsystem)
I/F Interface
IBM International Business Machines Corporation
ICD Interface Control Document
ICU Instrumentation Control Unit
ID Inside Diameter
IDB Internal Data Bus
IDCA Image Disector Camera Assembly
IDT Instrument Development Team
IEHT Intensifier Electrical High Tension
IOU Input Output Unit
IPCU Interface Power Control Unit
IR Infrared
IRD Interface Requirements Document

JHU Johns Hopkins University
JPL Jet Propulsion Laboratory
JSC Johnson Space Center

k Kilo (1000)
KBPS Kilobits per Second
Kbytes Kilobytes
KCRT Keyboard Cathode Ray Tube
kg Kilogram
km Kilometer
KSC Kennedy Space Center
kV Kilovolts

lb Pound
LGA Low Gain Antenna
LHCP Left Hand Circular Polarization
LiF Lithium Fluoride
LLD Low Level Discrete
LMSC Lockheed Missiles & Space Company, Inc.
LOS Line of Sight
Loss of Signal
LS Light Shield
LSB Least Significant Bit

m Meter
M&R Maintenance and Refurbishment
MA Multiple Access
mA Milliampere
MBA Main Baffle Assembly
MBPS Megabits per Second
MCE Monitor and Control Electronics
MCU Mechanisms Control Unit

ACRONYMS/ABBREVIATIONS
(Continued)

LMSC/D974197 B
31 May 1985

MDB Multiplexed Data Bus
MFR Manipulator Foot Restraint
Mg Magnesium
MgF₂ Magnesium Fluoride
Mgt Management
MHz Megahertz (10⁶ Hz)
MIT Massachusetts Institute of Technology
MLI Multilayer Insulation
mm Millimeter
MM Maintenance Mission
MMC Martin Marietta Corporation
MMS Multimission Modular Spacecraft
MOGS Mission Operations Ground System
MOI Moment of Inertia
MOWG Mission Operations Working Group
MP Maintenance Platform
MPT Mission Planning Terminal
MPXLR Multiplexer
MR Main Ring
MRA Main Ring Assembly
MSFC Marshall Space Flight Center
MSS Magnetic Sensing System
MT Magnetic Torquer
MTA Metering Truss Assembly
MTB Magnetic Torque Bar
MTE Magnetic Torquer Electronics
MTP Master Timing Pulse
MTS Magnetic Torquing System, Metering Truss Structure
MU Memory Unit
Mv Apparent Visual Magnitude

N Newton
N/A Not Applicable
NASA National Aeronautics and Space Administration
NASCOM NASA Communications Network
NCC Network Control Center
NCCDS Network Control Center Data System
nm Nanometers (10⁻⁹ meters)
NM nautical miles
NOCC Network Operations Control Center
NRZ Non-Return to Zero
NSSC-I NASA Standard Spacecraft Computer, Model-I

OB Optical Bench
OBC On-Board Computer
OCE Optical Control Electronics
OCS Optical Control Subsystem
OD Outside Diameter
OSCF Operation Support Computing Facility
OCXO Oven Controlled Crystal Oscillator
OLD Off-Load Device
OMS Orbital Maneuvering System
ORU Orbital Replaceable Unit
OSS Office of Space Science
OSFC Operations Support Computing Facility

ACRONYMS/ABBREVIATIONS
(Continued)

LMSC/D974197 B
31 May 1985

OSTDS Office of Space Tracking and Data Systems
OTA Optical Telescope Assembly

P-E Perkin-Elmer Corporation
PASS POCC Application Software Support
PC Planetary Camera
PCEA Pointing Control Electronics Assembly
PCS Pointing Control Subsystem
PCU Power Control Unit; Power Converter Unit (module of DF-224)
PDA Photon Detector Assembly
PDM Primary Drive Motor, Primary Deployment Mechanism
PDU Power Distribution Unit
PFR Portable Foot Restraint
PI Principal Investigator
PID Proportional Integral Derivative
PIP Payload Integration Plan
PIT Processor Interface Table
PLL Phase-Locked Loop
PM Primary Mirror
PMA Primary Mirror Assembly
PMT Photomultiplier Tube
PN Pseudo-Random Noise
POCC Payload Operations Control Center
POS Position
PRLA Payload Retention Latch Assemblies
PSEA Pointing/Safing Electronics Assembly
PWR Power
PX Pixel

QD Quick Disconnect

R-S Reed-Solomon
RAM Random-Access Memory
RCDR Recorder
RCS Reaction Control System
RDA Rotary Drive Actuator
RF Radio Frequency
RFI Radio Frequency Interference
RGA Rate Gyro Assembly
RIG Rate Integration Gyros
RIU Remote Interface Unit
RM Remote Module
RMES Retrieval Mode Electronics Assembly
RMGA Retrieval Mode Gyro Assembly
RMS Remote Manipulator System
ROM Read-Only Memory
RPA Reactive Plate Assembly
RPM Revolutions per Minute
RSU Rate Sensing Unit
RTC Real Time Command
RU Remote Unit
RW Reaction Wheel
RWA Reaction Wheel Assembly

ACRONYMS/ABBREVIATIONS
(Continued)

LMSC/D974197B
31 May 1985

S&M Structures and Mechanical (subsystem)
S/N Signal-to-Noise Ratio
S/W Software
SA Solar Array
SAA South Atlantic Anomaly
SAD Solar Array Drive
SADE Solar Array Drive Electronics
SADM Solar Array Drive Mechanism
SBA Secondary Baffle Assembly
SC Science
Sci Science Institute
SciF Science Institute Facility
SCP Stored Command Processor
SD Science Data
SDC Serial Digital Commands
SDF Science Data Formatter
SDM Secondary Deployment Mechanism
SDS Science Data Store
SEA Sensor Electronics Assembly
SE Systems Engineering (for documents)
SE Support Equipment
SI Scientific Instrument
S1,S2,S3 Solar Array Coordinate System
SI C&DH SI Control and Data Handling (subsystem)
SIMA Secondary Mirror Incremental Motor Actuator
SiO2 Silicon Dioxide
SIPE Scientific Instrument Payload Enclosure
SISS Scientific Instrument Support Structure
SM Secondary Mirror
SMA Secondary Mirror Assembly
SMB Secondary Mirror Baffle
SMC Safe Mode Command
Safe Mode Computer
SMCH Standard Mixed Cargo Harness
SMEA Safe Mode Electronics Assembly
SMM Spectro-Mirror Mechanism
SMRD Spin Motor Rotation Detector
SMSA Secondary Mirror Subassembly
SPA Solar Panel Assembly
SPC Stored Program Command
SPEC Specification
SPG Single Point Ground
SPM Sun Point Mode
SSA S-band Single Access
Star Selector Assembly
SSC Science Support Center
SSE Space Support Equipment
SSM-ES SSM-Equipment Shelf
SSM Support Systems Module
SSP Standard Switch Panel
SS Safing System
SSS Star Selector Servos
SIPE Support Structure
ST Space Telescope, common name for Hubble Space Telescope
STS Space Transportation System

ACRONYMS/ABBREVIATIONS
(Concluded)

LMSC/D974197B
31 May 1985

STA Station
STACC Standard Telemetry and Command Components
STDN Space (flight) Tracking and Data Network
STINT Standard Interface
STOCC Space Telescope Operations Control Center
STS Space Transportation System
STSS Space Telescope Safing System
ST Sci Space Telescope Science Institute

TAG Two-Axis Gimbal
TBD To Be Determined
TCE Thermal Control Electronics
TCS Thermal Control Subsystem
TDRS Tracking and Data Relay Satellite
TDRSS Tracking and Data Relay Satellite System
TDRSSGT TDRSS Ground Terminal (White Sands, New Mexico)
Ti Titanium
TiO₂ Titanium Dioxide
TLM Telemetry
TR Tape Recorder
TRACC Standard Telemetry and Command Components
TRW Thompson Ramo Woolridge, Inc.
TV Thermal Vacuum
TYP Typical

UC University of California
UCSD University of California, San Diego
ULE Ultra Low Expansion
μm Micrometer (10⁻⁶ m)
UT University of Texas
UT Universal Time
UV Ultraviolet

V Volt
V1,V2,V3 ST Coordinate System
VPU Video Processing Unit

W Watt
WBS Work Breakdown Structure
WEAR WBS Element Audit Review
WFC Wide Field Camera
WF/PC Wide Field Planetary Camera
WT Weight

X,Y,Z STS Coordinate System
ZOE Zone of Exclusion

** Exponent, example 10 to the 10th power (10¹⁰)

1.0 INTRODUCTION

1.1 Purpose

The Space Telescope Systems Description Handbook provides in one document the general description of the Hubble Space Telescope and its major systems and subsystems. It is intended for use by personnel engaged in Space Telescope activities.

1.2 Scope

The handbook represents a compilation of current data and descriptive information extracted from several sources in accordance with DR-SE-02 of NASA-MSFC NAS8-32697.

This handbook is divided into the following major elements: Overview of the Space Telescope, Support Systems Module, Optical Telescope Assembly, Scientific Instruments, Scientific Instruments Control and Data Handling, Solar Array, Mission Operation Ground System, and Crew and Hardware Interface. Included within this document are: configuration drawings, weights and mass properties, systems and subsystems descriptions, module equipment lists, schematics, module and Space Telescope interface descriptions with a general definition of performance capability.

Appendix A provides a summary of the Space Telescope system and subsystem weights and mass properties. Appendix B contains document trees for the Space Telescope and the Crew Systems. Appendix C provides the electrical schematics table of contents referenced in document ST/SE-33, and Appendix D presents six configuration drawing charts that show the inboard/outboard profile of the Space Telescope.

1.3 Preface

The objective of the Space Telescope Project is to orbit a high quality optical 2.4-m telescope system by the Space Shuttle for use by the astronomical community in conjunction with NASA. The scientific objectives of the Space Telescope are to determine the constitution, physical characteristics, and dynamics of celestial bodies; the nature of processes which occur in the extreme physical conditions existing in stellar objects; the history and evolution of the universe; and whether the laws of nature are universal in the space-time continuum.

Like ground-based telescopes, the Space Telescope was designed as a general-purpose instrument, capable of utilizing a wide variety of scientific instruments at its focal plane. This multi-purpose characteristic will allow the Space Telescope to be effectively used as a national facility, capable of supporting the astronomical needs for an international user community and hence making contributions to man's needs. By using the Space Shuttle to provide scientific instrument upgrading and subsystems maintenance, the useful and effective operational lifetime of the Space Telescope will be extended to a decade or more.

1.3.1 Why Space Telescope?

Man's concept of the universe has drastically changed in the past century. Improved observational and instrumentation techniques and analytical tools provided the opportunities for evolving this clearer understanding of the universe. With each significant improvement in observation capability, deeper insights into the composition, evolution, and processes of the universe have been made possible. Indeed astronomy as a science has yielded outstanding contributions to the understanding of physical processes and formulation of physical laws, e.g., gravity, that affect all aspects of our lives. Much has been learned, but much remains to be understood, including the extent and geometry of the universe, the past history and the future of the universe, and the many diverse and violent physical processes which occur in various stars, galaxies, and other celestial objects.

The 200-in. aperture Hale telescope at Palomar Mountain, California, can recognize individual galaxies several billion light years away. However, like all earthbound devices, the Hale telescope has limited resolution because of the blurring effect which the earth's atmosphere causes due to its turbulence and light scattering. The wavelength region observable from the earth's surface is limited by the atmosphere to the visible part of the spectrum. Unlike ground-based telescopes, the 2.4-m Space Telescope will possess and can effectively utilize an optical quality of such precision that its resolving power is limited primarily by the diffraction limit of the optics. The Space Telescope will be taken into earth orbit by the Space Shuttle and, from there, unhindered by atmospheric distortion and absorption, it can see objects with a resolution approximately seven to ten times better than that obtainable even with the largest telescopes on earth and over a wavelength region which reaches far into the ultraviolet (UV) and infrared (IR) portions of the spectrum. Objects at seven billion light years, for example, can be seen with the Space Telescope with as much detail as objects at one billion light years can be seen with the best earthbound telescopes.

NASA and the scientific community have, for the past several years, been evolving the technological and operational capabilities which are needed to utilize that technology effectively. These technology advancements have occurred as a natural result of other orbiting astronomical satellite programs such as Orbiting Astronomical Observatory (OAO), Orbiting Solar Observatory (OSO), and Apollo Telescope Mount (ATM), as well as through supporting research and technology activities. In addition, a number of Space Telescope mission definition and design activities were conducted within the agency and by contractors. Based on need and state of technology, Space Telescope is the next logical step in astronomy.

1.3.2 Specific Scientific Objectives

The overall scientific objectives are to gain a significant increase in our understanding of the universe through observations of celestial objects and events. The ST has been designed and developed to achieve the following specific scientific objectives:

- o Precise determination of distances to galaxies out to expansion velocities of $1 \times 10^{*4}$ km/sec and calibration of distance criteria applicable at cosmologically significant distances
- o Determination of the rate of the deceleration of the Hubble expansion of the universe, its uniformity in different directions, and possibly its constancy with time
- o Testing of the basic reality of the universal expansion by determination of the surface brightness versus redshift relation for distant galaxies
- o Establishment of the history of star formation and nuclear processing of matter as a function of position in nearby galaxies and determination of the variations from galaxy to galaxy
- o Determination of the nature of stellar populations in the early stages of galactic evolution, based on "lookback" observation of distant galaxies
- o Estimation of the He/H ratio in quasars by observation of red-shifted He I and He II resonance lines
- o Search for multiple-red-shift absorption line groups in the ultraviolet spectra of low-red-shift quasars
- o Intercomparison of total spectra of high-red-shift quasars, low-red-shift quasars, and active galactic nuclei
- o Resolution of densely-packed nuclei of globular star clusters in search of massive black holes
- o Identification and flux measurement in ultraviolet and optical wavelengths of faint X-ray sources and radio pulsars
- o Resolution of the complex internal structure of Herbig-Haro objects to investigate their possible links to star formation
- o High spatial resolution, infrared observations of proto-stars
- o Direct imaging and astrometric search for planetary companions of nearby stars
- o Determination of bolometric luminosities of faint, hot stars for studies of stellar evolution

31 May 1985

- o Determination of composition, temperature, density, and ionization structure of the gas in the galactic halo, in high-velocity clouds, and in the intergalactic medium
- o Precise mapping of the 100 μm flux sources in compact H II regions
- o Determination of composition of clouds in the atmospheres of Jupiter, Saturn, Uranus, and Neptune
- o Resolution of surfaces of minor planets and asteroids
- o Synoptic mapping of atmospheric features on Venus, Jupiter, Saturn and Uranus for study of atmospheric dynamics
- o Intensity measurements of atomic and molecular ultraviolet emission lines important to understanding the chemistry of comets.

The primary objective of ST design and development is to provide a high resolution, optical telescope system that will meet these scientific objectives and perform them within the operational life of the ST.

The scientific and technological requirements will be fulfilled within the anticipated mission operational life of 15 years. In principle there is no reason the mission operation could not be operated for many decades. Because the Science Instruments (SIs) and some of the electronics are of modular design they can be replaced with improved or different models. Periodic orbital maintenance and altitude reboost via the Shuttle Orbiter is planned. If major refurbishing is necessary it will be possible to retrieve the ST, return it to earth and relaunch.

2.0 OVERVIEW

The NASA Hubble Space Telescope (ST) is an astronomical observatory to be placed in an approximately circular orbit at 593 km (320 NM) altitude, at an inclination angle of 28.5 deg and an orbital period of approximately 95 min. Operating well above the earth's turbulent atmosphere, the ST will: observe the ultraviolet, visible, and infrared wavelength regions of the faintest objects; achieve an increase in spatial resolution that is seven or more times better than the capability of ground-based observatories for a wide range of objects; detect objects approximately 50 times fainter than are presently observable and view them with ten times better clarity than ground-based observatories. This capability will expand the universe visible to man by 350 times and enable him to see close to the edge of the observable universe at objects an estimated 14 billion light years away.

2.1 General Configuration

The ST launch weight will be approximately 11,600 kg (25,500 lb); it will be 13.1 m (43.5 ft) long and have a diameter of 4.27 m (14 ft) at the aft end and have a diameter of 3.05 m (10 ft) at the forward end. The spacecraft illustrated in Figure 2-1 is built to work much like a ground observatory. In principle, it is no different than the reflecting telescopes invented by Guillaume Cassegrain and James Gregory in the 17th Century. This figure defines the location of the ST's major external surface elements and the cutaway section views some of the major support sections. Figure 2-2 is an exploded view of the ST modules to show their relative positions.

2.1.1 External Structure

o The Support System Module (SSM) is divided into four main sections; the Light Shield (LS), the Forward Shell (FS), the Equipment Section (ES), and the Aft Shroud (AS). These four pieces fit together like stacked canisters, to enclose the Optical Telescope Assembly (OTA), Scientific Instruments (SIs), and electrical/mechanical modules to provide power, communications, pointing and control, and other support systems required for successful operation.

o The Aperture Door (AD) located at the ST forward end is attached to the SSM LS and may be positioned relative to the Sun, Moon or Earth to shade and protect the sensitive SIs from electromagnetic radiation and degrading the focal plane image.

o The Magnetic Torquers (MTs) are attached to the external surface of the SSM FS at four positions. The MTs are magnetized metal rods controlled by an onboard, triple-redundant computer to align the spacecraft with the earth's magnetic field. Working in conjunction with four attitude control reaction wheels located within the SSM ES the attitude of the spacecraft may be controlled.

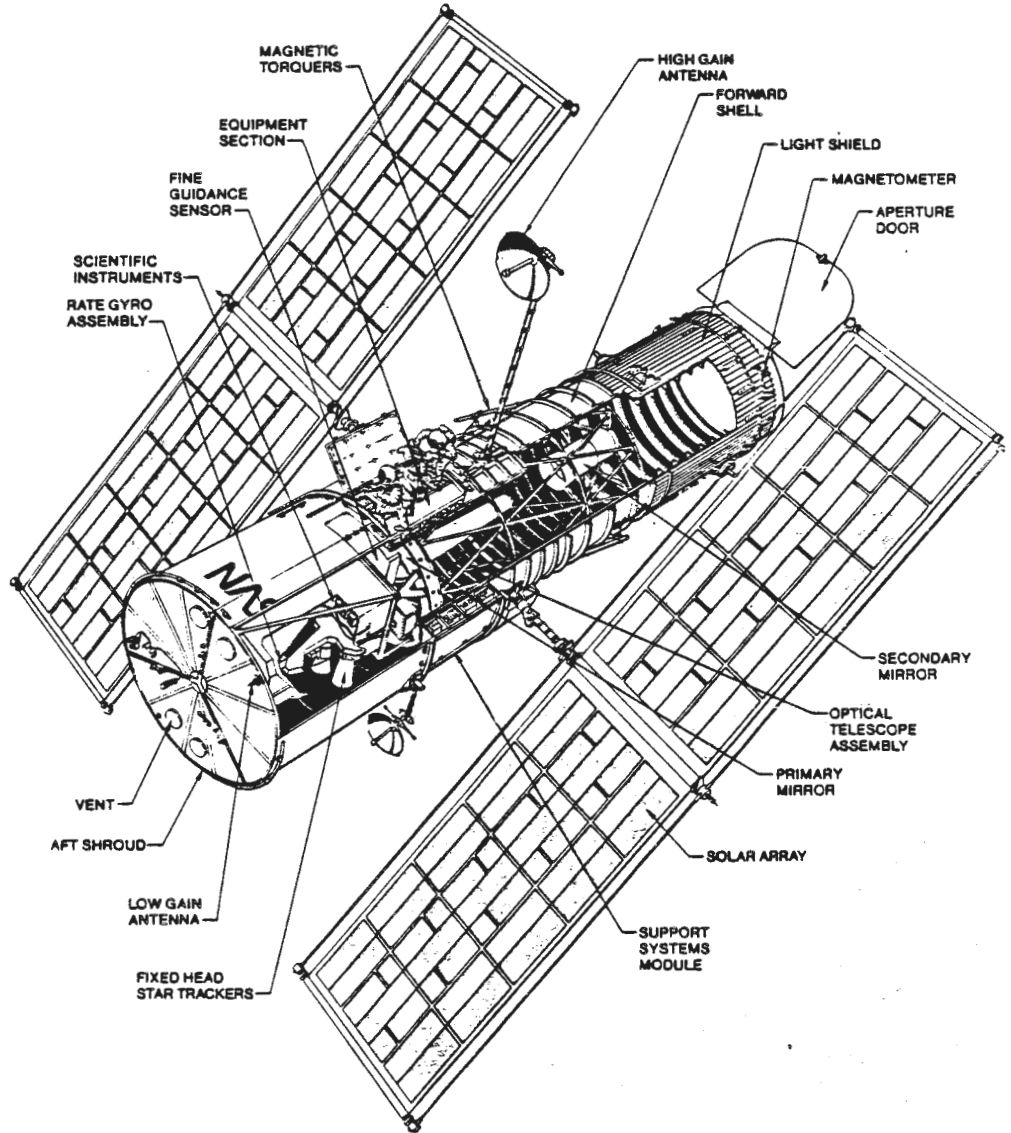

Figure 2-1 Hubble Space Telescope

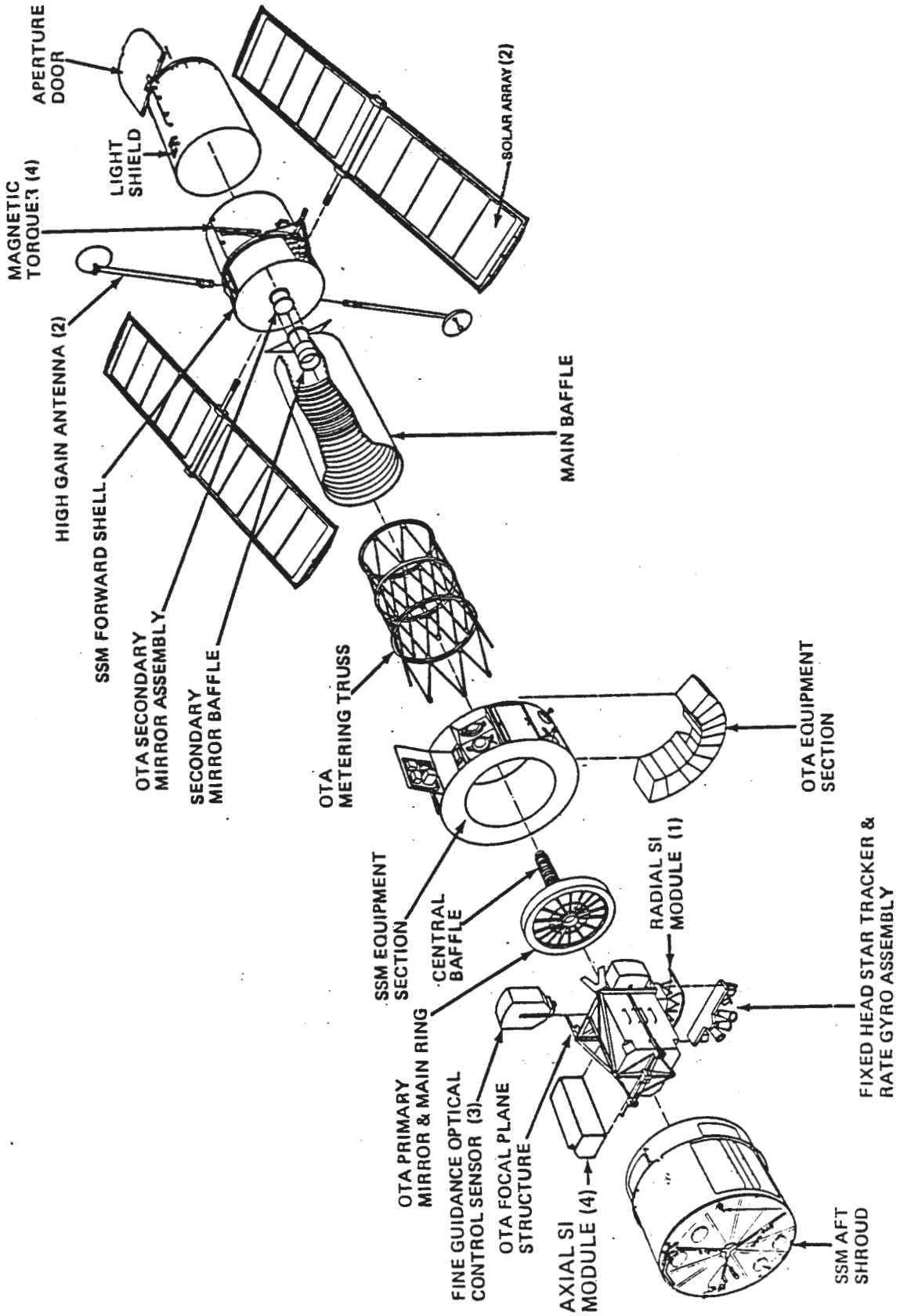

Figure 2-2 Space Telescope Exploded View

o High Gain Antennas (HGAs) are attached to the exterior surface of the SSM FS at two locations. While in the Shuttle bay the HGA is in a latched position located on the SSM LS. The reversible motor-driven hinge mechanism is used to deployed the HGA for on-orbit use or retracted for ST retrieval.

o The Solar Arrays (SAs) are attached to the exterior of the SSM FS at two locations. While in the Shuttle bay the SA is latched at a position located on the SSM LS. The deployment mechanism interfaces via an adapter with the Solar Array Drive Mechanism (SADM). The deployment and unfurling mechanisms are controlled by the Deployment Control Electronics (DCE).

o Handrails and portable foot restraints are fixed on the external surface to permit astronauts to perform Maintenance and Refurbishment (M&R) tasks.

o Access to many of these modules will be relatively easy as some compartments can be opened from the outside via a hatch or Access Door (AD). An astronaut opens the cover to get at the module needing replacement, disconnects the module from the plug-in compartment, and inserts a replacement. Among the components in the ES are the Reaction Wheel Assembly (RWA), Digital Interface Units (DIU), communication system, batteries, and charge controller. The AS fits over the section which contains the four axial SIs, one radial SI, and three Fine Guidance Sensors (FGS). Access covers on this shroud enable astronauts to get at the other instruments such as the Fixed Head Star Tracker (FHST), Rate Gyro Assembly (RGA), and other sensors, for maintenance or removal.

o The Aft Bulkhead (AB) of the SSM AS contains four vents to equalize differential pressure during launch and recovery operations. An omnidirectional Low Gain Antenna (LGA) and two Coarse Sun Sensors (CSS) are also mounted to the AB.

o The OTA Equipment Section is a 150-deg toroidal structural assembly attached to the SSM FS and the forward face of the SSM ES. This section is slotted at the forward end for the HGA attachment to the FS.

2.1.2 Support Systems

o The Focal Plane Structure (FPS) consists of two-piece separable assembly consisting of the Focal Plane Deck Assembly (FPDA) and the Scientific Instrument Support Structure (SISS). The FPDA interfaces with the Main Ring (MR) and provides the forward support for the SSM Equipment Shelf (SSM-ES). The SISS supports the aft end of the SSM-ES.

o The three Fine Guidance Systems (FGSs) and the Wide Field/Planetary Camera (WF/PC), the only radial SI, are housed within the FPDA and are supported by latches to permit removal on orbit.

- o The Faint Object Spectrograph (FOS), High Resolution Spectrograph (HRS), High Speed Photometer (HSP), and the Faint Object Camera (FOC) are the four radial SIs mounted in the SISS and supported by latches to permit removal on orbit.
- o The Fixed Head Star Tracker (FHST) and three rate gyro assemblies called the Rate Sensor Units (RSUs) are mounted to the SSM-ES.
- o The Main Ring Assembly (MRA) is the primary load carrying structure to which all OTA subassemblies such as the Primary Mirror Assembly (PMA), Secondary Mirror Assembly (SMA), Focal Plane Structure Assembly (FPSA), Reaction Plate Assembly (RPA), Axial OTA/SSM Links, Tangential OTA/SSM Links and Main Baffle (MB) are attached.
- o The Central Baffle Assembly (CBA) is located just in front of the Primary Mirror (PM), while a Secondary Baffle (SB) fits just behind the Secondary Mirror (SM).
- o A large aluminum Main Baffle Assembly (MBA) extends from the PM to just beyond the SM and is supported by the MR. The SBA is located concentric with and just inside the Metering Truss Assembly (MTA).
- o The OTA Metering Truss Assembly (MTA) separates and supports the MRA and the Secondary Mirror Subassembly (SMSA).

2.1.3 Coordinate Systems

Three coordinate systems are defined in Figure 2-3 for the Orbiter, ST, and the ST Solar Arrays (SA). While in the Orbiter payload bay the ST coordinates (V1,V2,V3) are related to the Orbiter coordinates (X,Y,Z). The SA coordinates (S1,S2,S3) are referenced to the SA attach points.

The V1 origin is 6.096 m (240-in.) behind a plane through the OTA/SSM interface on the ST centerline (optical axis). The ST centerline is identical to V1 axis and is positive toward the SSM aperture door. The V3 axis is perpendicular to the V1 axis and the SA drive axis and is positive along the nominal sun direction (solar arrays in the V1, V2 plane, the sun perpendicular to the active side of the SA). The V2 axis is parallel to the SA drive axis and directed to form a right-hand coordinate system. When the ST is in the Orbiter V1 = 0 is at Orbiter station X = 1250 in., V2 = 0 at Orbiter station Y = 0 and V3 = 0 at Orbiter station Z = 400 in.

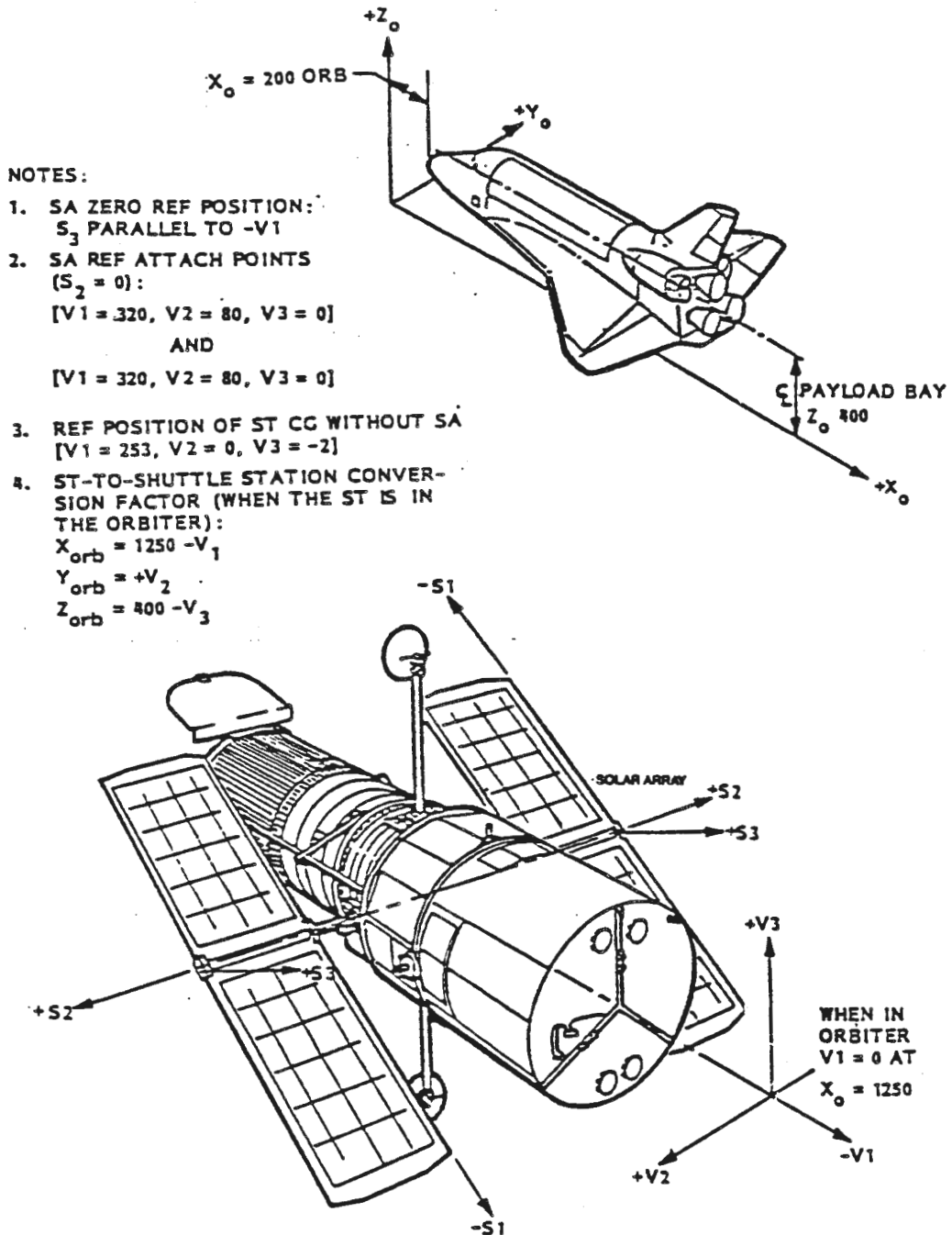

Figure 2-3 Orbiter/ST Coordinate Relationships

2.2 ST Major Elements

2.2.1 Support System Module (SSM)

The SSM (Figure 2-4) is the major component of the ST which houses the Optical Telescope Assembly (OTA), Scientific Instruments (SIs), and the Scientific Instruments Control and Data Handling (SI C&DH) Subsystem, and supports the OTA equipment section.

The physical relationship of the SSM, OTA, OTA equipment section, and SIs are shown in Figure 2-4. The SSM provides structural support, thermal control, electrical power, communications, data management, pointing control in support of the OTA, OTA equipment section, SI, SI C&DH, and the ST system. The SSM structure is composed of the following major components: Aperture Door (AD), Light Shield (LS), SSM Forward Shell (FS), SSM OTA Equipment Sections (ESs) with electrical equipment, Aft Shroud including Aft Bulkhead (AS/AB), and Mechanisms.

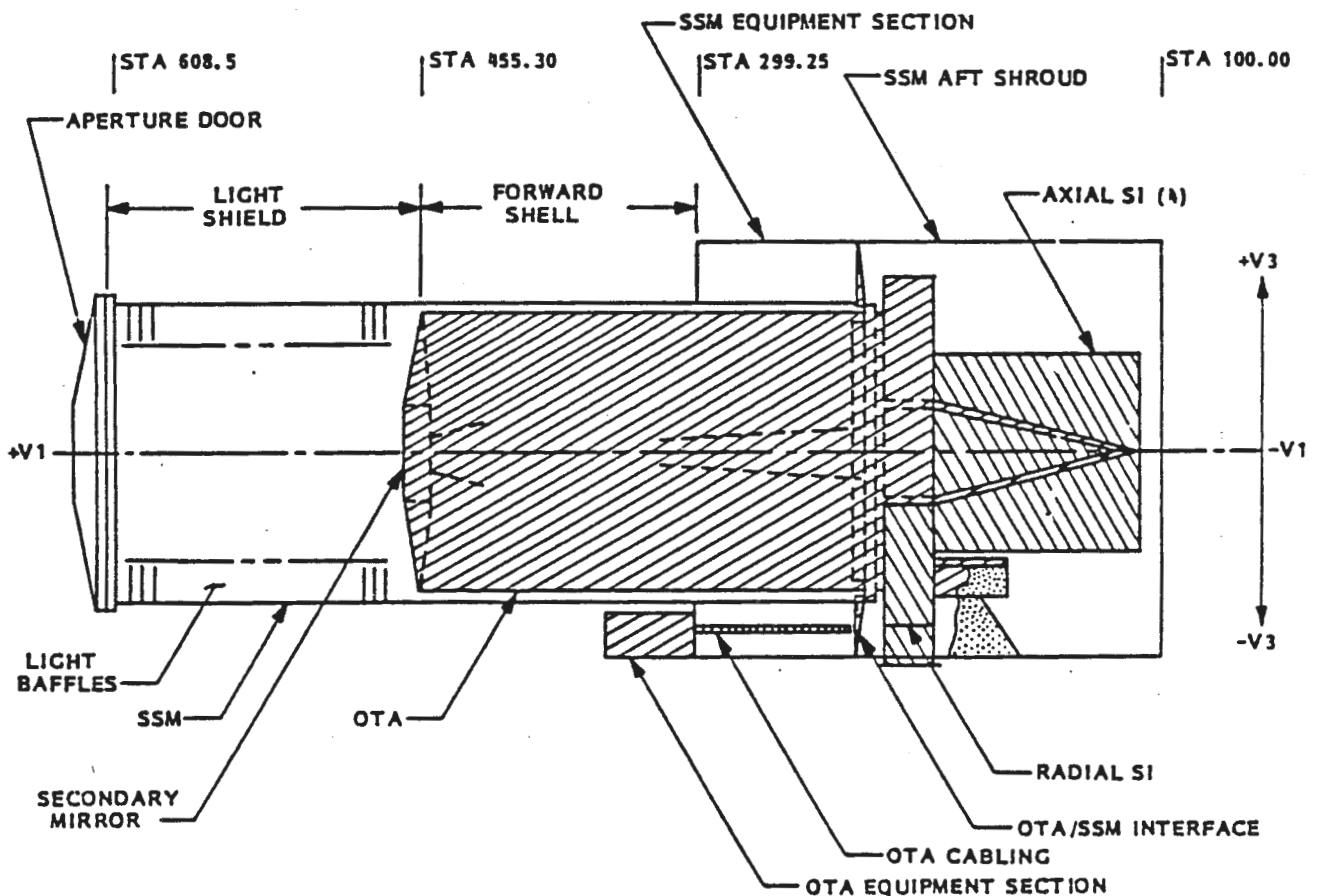

Figure 2-4 Support System Module - Design Features

2.2.2 Optical Telescope Assembly (OTA)

The OTA (Figure 2-5) is the core of the ST and includes the 2.4-m, f24, Ritchey-Chretien Cassegrain-type telescope. The OTA is composed of the following major components: Focal Plane Structure, Primary Mirror, Main Ring, Central Baffle, Main Baffle, Graphite Epoxy Metering Truss, Secondary Mirror Baffle, Secondary Mirror Assembly, and Equipment Section with electrical equipment.

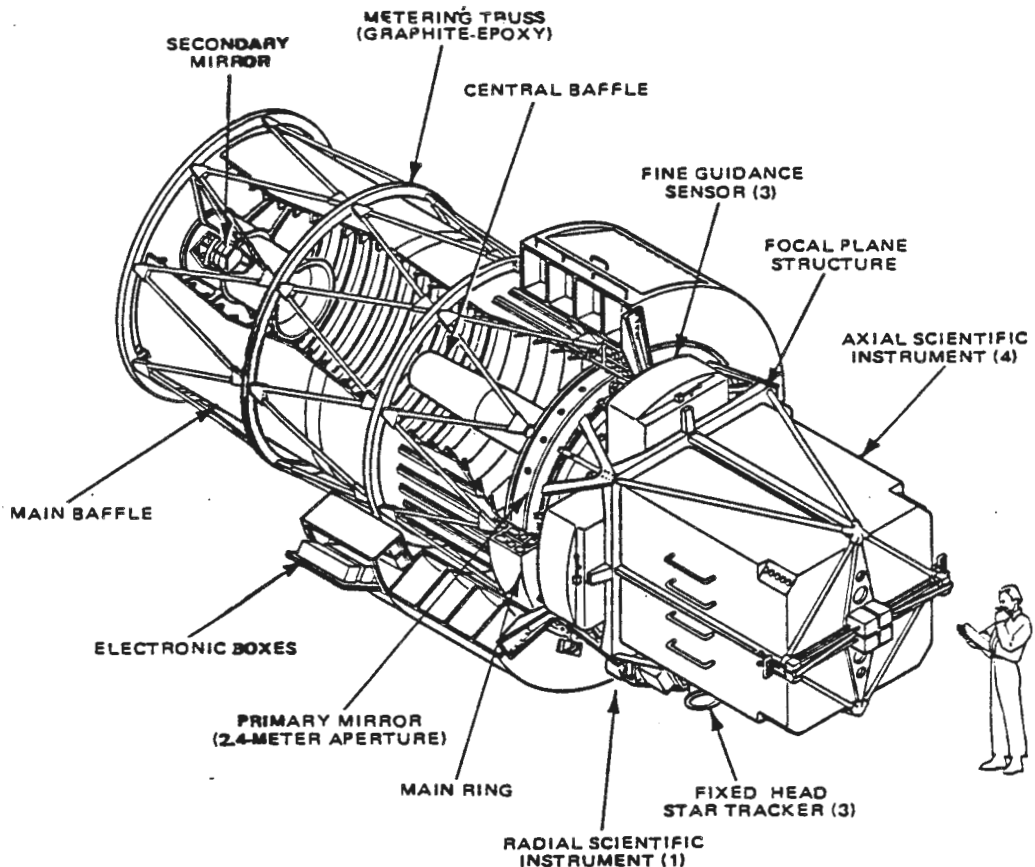

Figure 2-5 Optical Telescope Assembly - Design Features

The light from a star or other object travels through the aperture, down the assembly, and past the secondary mirror. The light then strikes the primary mirror where the beam is narrowed and is reflected to the secondary mirror where it is intensified into a small diameter beam. A meteoroid shield sun shade protects these optics. The beam passes through a 24-in. hole in the primary mirror to the focal plane almost five feet behind it. The focal plane is where the light originally captured by the primary mirror is turned into a focused image. Parts of the image enter the apertures of the SIs and are transmitted as data. The mirrors will be kept at nearly constant temperatures so that images at the focal plane will not be distorted by changes in the environment. These images, as well as other SD, are converted to electronic digitized signals. The data are transmitted by means of high-gain antennas at a speed of up to one million bits per second.

2.2.3 Scientific Instruments (SIs)

The initial complement of SIs (Figure 2-6) include two cameras, two spectrometers, and a photometer. The Faint Object Camera (FOC), High Resolution Spectrograph (HRS), Faint Object Spectrograph (FOS), and the High Speed Photometer (HSP), are located in the axial position connected to the OTA Focal Plane structure (FPS). The Wide Field Planetary Camera (WF/PC) is a radial SI.

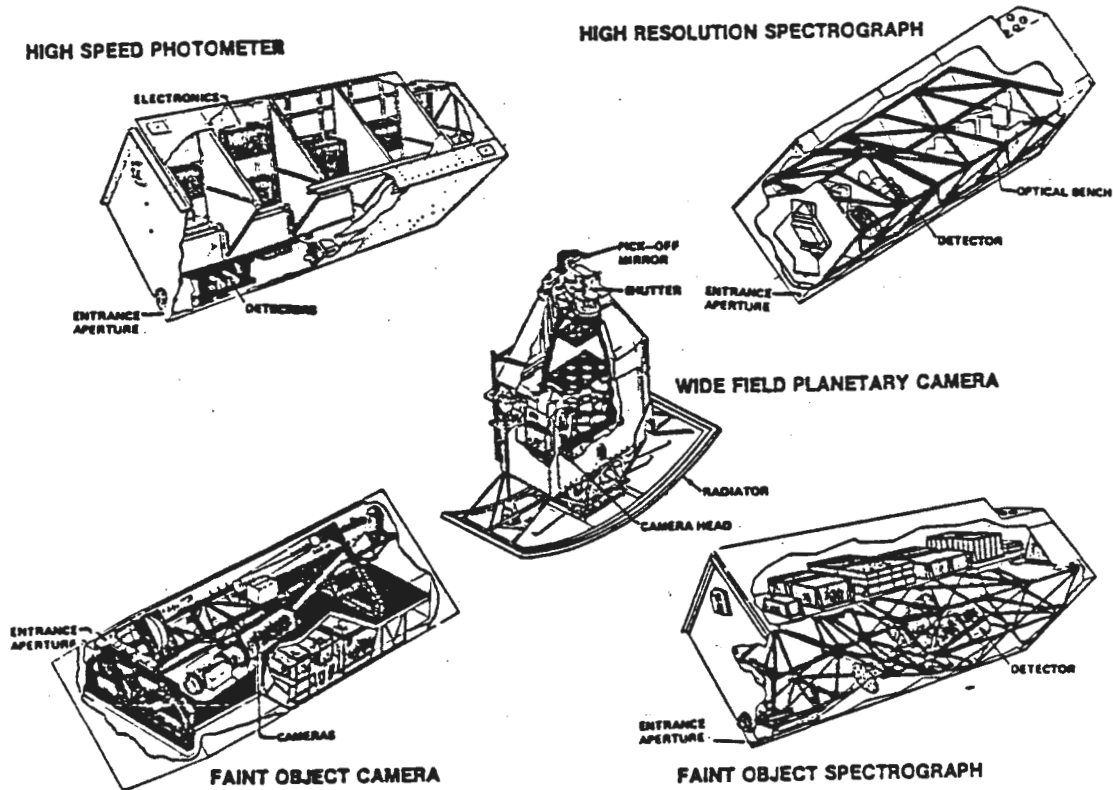

Figure 2-6 Scientific Instruments

The FOC and the WF/PC are distinguished by their field of view, spatial resolution and wavelength range. Both instruments cover the ultraviolet and blue regions of the spectrum. The WF/PC also covers the red and near-infrared regions with a field at least 40 times larger than the FOC, but with a resolution degraded by a factor of two to four. The FOC has a very small field of view, but can use the highest spatial resolution which the ST optics can deliver.

The HRS and the FOS provide a wide range of spectral resolutions which would be impossible to cover in a single instrument. Both instruments will record ultraviolet radiation. Only the FOS covers the visible and red regions of the spectrum.

The HSP is a relatively simple device capable of measuring rapid brightness variations over time intervals as short as 0.0001 sec. It can also be used to measure ultraviolet polarization and to calibrate other instruments.

2.2.4 SI Control and Data Handling (SI C&DH)

The SI C&DH (Figure 2-7) provides a unified command, data, and telemetry interface between the five SIs and the SSM Data Management System (DMS). The SI C&DH hardware is located in Bay 10 of the SSM Equipment Section and will provide the overall control of SI operations and data routing. The command software residing in the SI C&DH for each instrument will be reprogrammable, permitting modification of observing sequences as experience in the use of each instrument is gained. In addition, the instruments contain nonreprogrammable microprocessors that are used to implement internal control sequences and data handling functions.

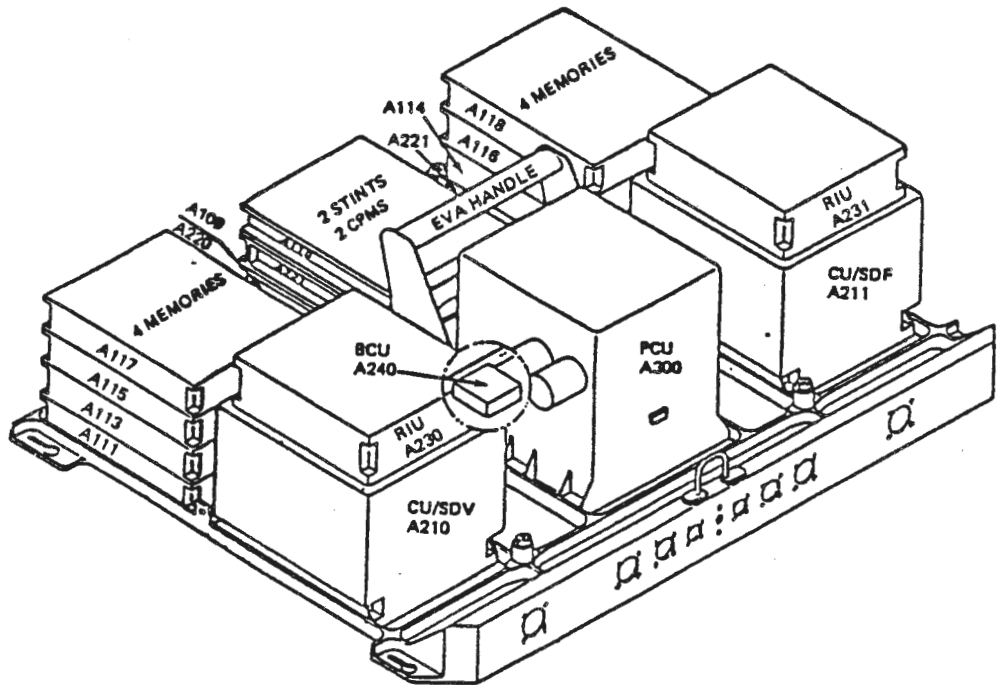

Figure 2-7 Scientific Instruments Control and Data Handling

Major functions of the SI C&DH include the reception, decoding and storage of commands. Collected SI Engineering Data (ED) and Science Data (SD) is transmitted to the DMS. Other functions include: command storage, buffering, and formatting of SD into a transmission format, error correction coding of SD to provide a general computing capability to support SI control, monitoring, and data manipulation/analysis. The SI C&DH provides a power interface between the SIs and the SSM by conditioning power and providing for internal SI C&DH power distribution and redundancy selection.

The components of the SI C&DH illustrated above are: Control Unit/Science Data Formatter (CU/SDF), Multiplexed Data Bus (MDB), Bus Coupler Unit (BCU), Remote Module (RM), Standard Interface for Computer (STINT), NASA Standard Spacecraft Computer, Model I (NSSC-I), and Power Control Unit (PCU).

2.2.5 Solar Arrays (SAs)

The two SAs, shown in Figure 2-8, are affixed externally to the ST at the Forward Shell. Prior to deployment, each blanket is contained on a cylinder 15 in. in diameter. The cylinder is pivoted against the side of the telescope. Each SA will be unfurled when the ST is deployed and measures approximately eight ft. by 40 ft. They provide at least 2400 W average power to recharge the SSMs six nickel-cadmium batteries each time the ST completes the sunside portion of its 95-min orbit. The two SAs along with the batteries and power conditioning equipment comprise the power supply system for the ST.

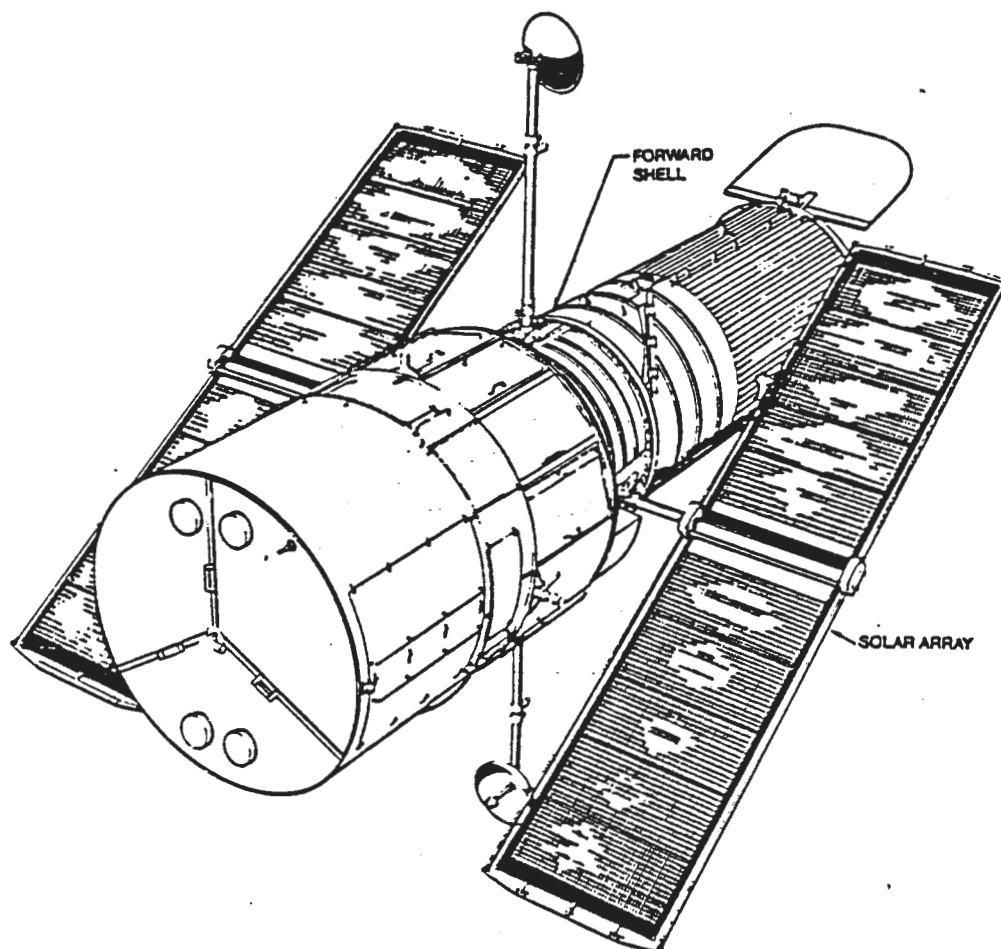

Figure 2-8 Space Telescope with Solar Arrays

Each array is comprised of two flexible solar cell blankets, storage drum, and the necessary deployment/retraction and orientation mechanisms. An Electronic Control Assembly (ECA) is mounted in Bay 7 of the SSM equipment section and consists of the Deployment Control Electronics and the SA Drive Electronics. Electrical power is generated by the solar cell panels and then passed to the SSM EPS for conditioning and distribution. Power for all SA motors and instruments is controlled by the Electronics Control Assembly (ECA), which also accepts commands from the SSM and conditions data from the SA system for transmission to the SSM DMS and PSEA.

2.3 Mission Operation Ground System (MOGS)

The MOGS (Figure 2-9) consists of the Space Telescope Operations Control Center (STOCC) located at GSFC, Greenbelt, Maryland. STOCC is the major facility for the scheduling and control of ST operations. STOCC is composed of the Payload Operations Control Center (POCC) and the Science Support Center (SSC). POCC represents the focal point for all mission operations including ST command and control, determination of operating constraints and restrictions, ST health and status monitoring, and contingency control of the ST. SSC represents the primary interface between the ST Sci and the POCC, including daily science scheduling, observer support, real time science operations, quick look data processing and display, and Scientific Data (SD) management. The SSC is the control point for science input and evaluation of SD. Also housed at GSFC is the ST Data Capture Facility (DCF) which receives SD from the ST and forwards it to the ST Science Institute (Sci) facility located at the Johns Hopkins University (JHU), Homewood Campus, Baltimore, Maryland.

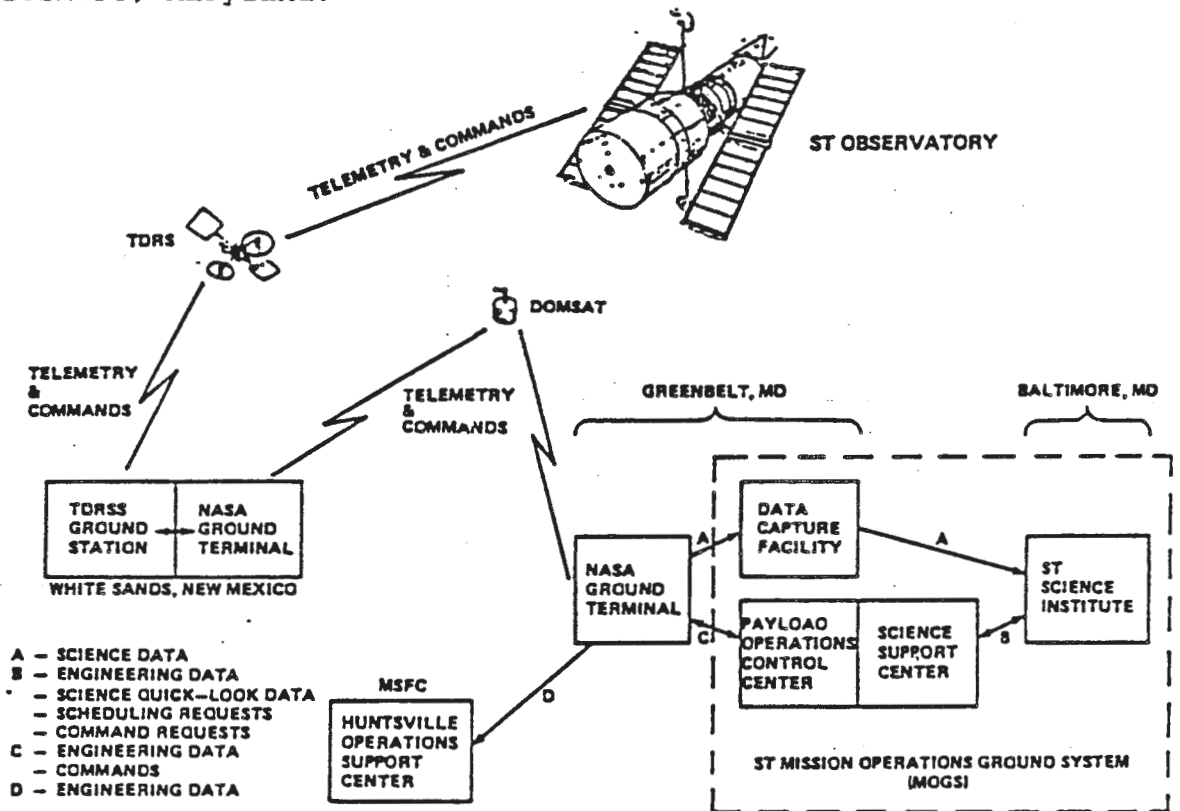

Figure 2-9 Mission Operation Ground System

The ST Sci conducts an integrated ST science program including the establishment of observing policy, selection and support of ST observers, detailed science planning, observation implementation, and data archiving, processing and analysis. In addition to operations at its own location, the ST Sci provides scientists and other staff to perform operations at the SSC.

The ST communication network (Figure 2-10) is described as follows: astronomers at the ST Sci, will decide where in the sky the ST should be pointed. Celestial coordinates are then transmitted via microwave link through the NASA Goddard Space Flight Center (GSFC), which is the Payload Operations Control Center (POCC). From GSFC, the commands pass through a commercial communications satellite to a ground relay station at White Sands, New Mexico, transmitted to a Tracking and Data Relay Satellite (TDRS) in geostationary orbit, and thence to the ST. Digitized images and data are transmitted from the ST over the reverse path to the ST Sci.

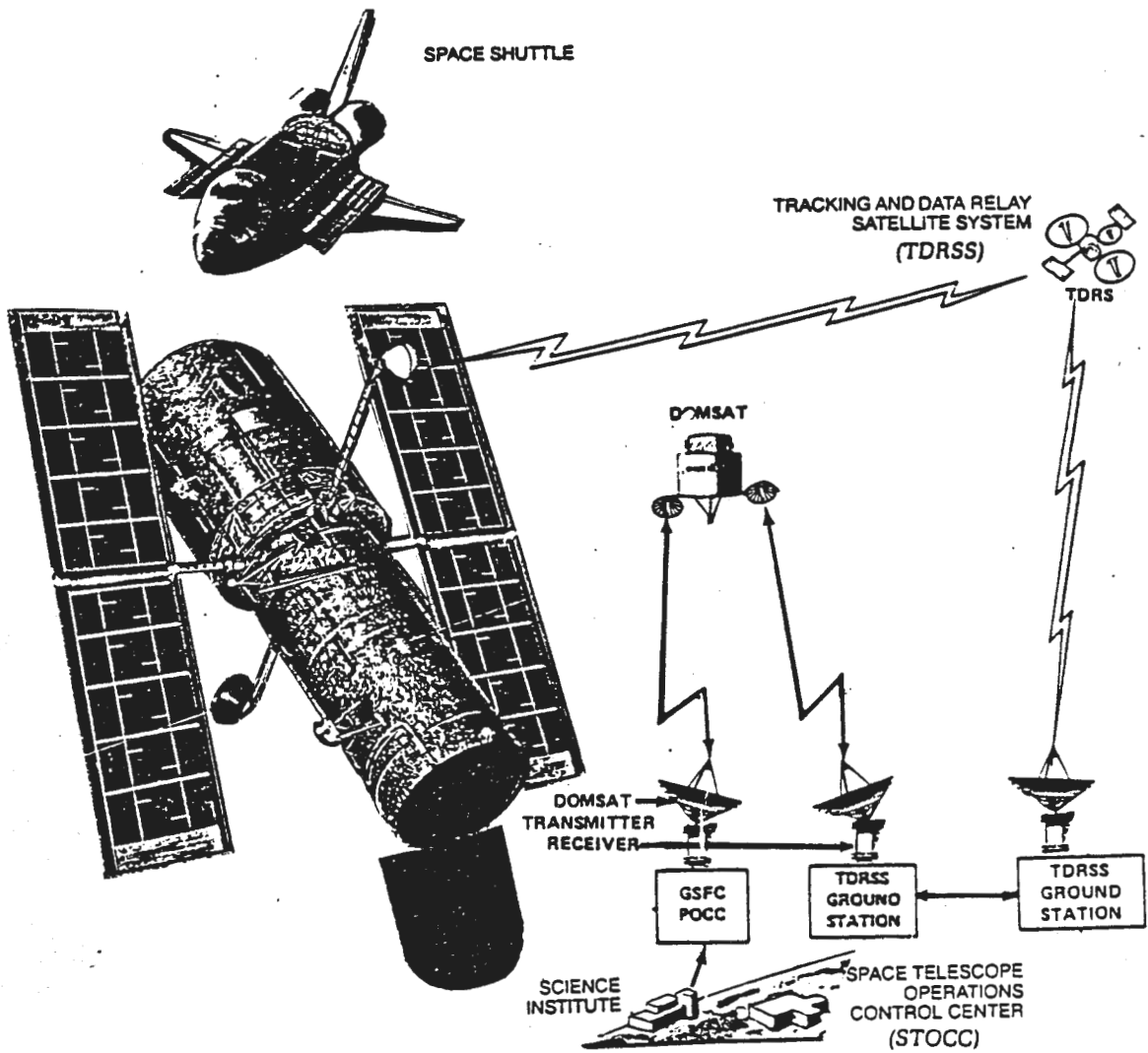

Figure 2-10 Space Telescope Communication Network

2.4 Space Support Equipment (SSE)

The SSE is the mechanical and electrical hardware which aids the astronaut crew in deploying and retrieving the ST as well as performing Extra Vehicular Activity (EVA) during Maintenance Missions (MM).

ST mounted crew aids permanently mounted to the ST includes translation rails, handholds, tether loops, foot restraint receptacles, deployment umbilical, astronaut control panel, portable light receptacles, flight support system interfaces, and miscellaneous SI/changeout hardware.

The STS mounted SSE hardware is used in the deployment and retrieval of ST and will be returned to earth with each mission. This hardware consists of the umbilical disconnect mechanism, Interface Power Control Unit (IPCU), astronaut tools, the umbilical mounting bracket, tool mounting bracket, portable foot restraint, and jettison handle.

Section 9, provides a description of the Crew/Hardware Interface of the SSE during MM. Orbital Replacement Units (ORUs) approximate size, weight, and ST location are listed and include Candidate ORUs (CORUs). Appendix A, Table A1-3 provides a listing of the SSE current weight values based on SSE Critical Work Element Audit Review (C-WEAR) data package. The SSE MM is briefly defined since a detailed description is beyond the scope of this handbook.

The Ground Support Equipment (GSE) is the mechanical and electrical hardware which are required for the installation, protection and operation of the ST prior to flight. These GSE are beyond the scope of this handbook. Other GSE such as communication hardware utilized during flight are defined briefly in Section 8 (Mission Operations Ground System).

ORU - CHANGEOUT

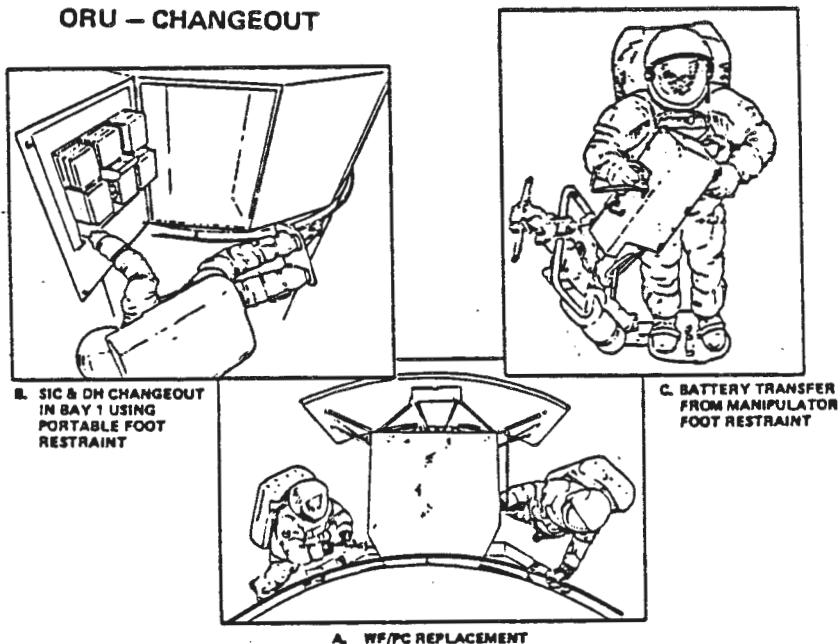

2.5 Management Responsibility

The execution of the Space Telescope (ST) design/development and mission/science operation activity involves the participation of several NASA Headquarters offices and NASA centers, associate contractors, national agencies, and other individual contracts for the major ST Project elements.

2.5.1 NASA Centers

2.5.1.1 Office of Space Science (OSS)

OSS, Headquarters, Washington, D.C., is responsible for the agency-wide planning and direction of the Space Science Program. Within OSS, the Associate Administrator for Space Science has delegated authority for the Space Telescope Program to the Director of the Solar Terrestrial and Astrophysics Division.

The Director of the Solar Terrestrial and Astrophysics Division has assigned responsibility for the Space Telescope Program to the ST Program Manager, who will maintain policy, goals and objectives, and will control the allocation of resources. The ST Program Scientist in the OSS is responsible for the overall science policy.

2.5.1.2 Marshall Space Flight Center (MSFC)

MSFC, Huntsville, Alabama, has been designated as the Project Management Center for the ST Project and has overall implementation responsibility for meeting cost, schedule, and technical performance goals of the ST Project, including participation of other centers. The MSFC Center Director has delegated authority to the ST Project Manager to manage and implement the ST Project.

The ST Project Manager heads a Project Office which is responsible for directing all NASA and contractors' efforts, for establishing and maintaining effective project management activities, and for preparing and maintaining the detailed technical specifications which will define the requirement for all elements of the project.

2.5.1.3 Goddard Space Flight Center (GSFC)

GSFC, Greenbelt, Maryland, is responsible to the ST Project for the ST Scientific Instruments (SIs), the SI Control and Data Handling (SI C&DH) Subsystem, the total ST ground system, the Science Institute, and the conduct of mission and science operations, including operations planning. Within GSFC, the Flight Projects Directorate (Code 400) is responsible for managing GSFC portion of the ST Project. Specifically, the Manager of the GSFC ST Project for Science and Operations (Code 440) is responsible for the cost, schedule, and performance of the GSFC portion of the ST Project.

2.5.1.4 Office of Space Tracking and Data Systems (OSTDS)

The OSTDS has overall management responsibility for NASAs tracking and data acquisition, which includes the TDRSS, NASCOM, and POCC activities, which will provide support to the ST Project. The Support Instrumentation Requirements Document (SIRD) covers OSTDS support for the mission.

2.5.1.5 Johnson Space Center (JSC)

JSC, Houston, Texas, is the lead center for Space Shuttle which will be used to place the ST on orbit, during MM to deploy, retrieve, and provide maintenance reboost operations. In response to overall ST project requirements, JSC is responsible for defining and establishing all crew system design and training requirements. These requirements, along with all STS interface requirements, are controlled by the Shuttle/Payload Integration and Development Program Office (SPIDPO) at JSC. The Payload Integration Plan (PIP) describes the integration requirements and implementation.

2.5.1.6 Kennedy Space Center (KSC)

KSC, Florida, is responsible for launch activities. The ST Project Office is working with KSC to develop requirements and support plans for launch site services for ST. The KSC effort is managed by the ST Launch Site Support Manager, working closely with the ST Project Office.

2.5.2 Associate Contractors and Agency

2.4.2.1 Lockheed Missiles & Space Company, Inc. (LMSC)

LMSC, Sunnyvale California, is the associate contractor for the Support Systems Module (SSM). The SSM contract includes design, development, fabrication, assembly, and verification of the SSM; integration of systems engineering and analysis for the overall ST; and support to NASA for planning and implementing ground, flight, and orbital operations support. The SIs and the OTA will be GFE to the SSM contractor.

2.5.2.2 Perkin-Elmer Corporation (P-E)

P-E, Danbury, Connecticut, is the associate contractor for the Optical Telescope Assembly (OTA). The OTA contract includes design, development, fabrication, assembly, and verification of the OTA and support of ST integration and development operations.

2.5.2.3 European Space Agency (ESA)

ESA is participating in the ST Project, making specific contributions to the ST Project by providing the Solar Arrays (SA) and Faint Object Camera (FOC) and by providing personnel to participate in science operations activities.

31 May 1985

2.5.3 Major ST Project Elements

2.5.3.1 Scientific Instruments (SIs)

The Wide Field and Planetary Camera was developed under the leadership of J. A. Westphal of the California Institute of Technology.

The Faint Object Camera was developed by ESA under the leadership of F. Duccio Macchetto (Project Scientist) and H. C. Van den Hulst (Team Leader).

The Faint Object Spectrograph was developed under the leadership of R. J. Harms of the University of California, San Diego.

The High Resolution Spectrograph was developed under the leadership of J. C. Brandt of GSFC.

The High Speed Photometer was developed under the leadership of R. C. Bless of the University of Wisconsin.

2.5.3.2 Other Space Telescope Equipment

| | |
|---|---------------------|
| Actuator Control Electronics | P-E |
| Aft Latch, Solar Array | LMSC |
| Antenna Pointing System | Sperry |
| Battery | Eagle Picher/GE |
| Charge Current Controller | LMSC |
| Circulator Switch | Electromagnetic |
| Coarse Sun Sensor | LMSC |
| Computer | Rockwell Autonetics |
| Data Interface Unit | LMSC |
| Data Management Unit | LMSC |
| Deployment Control Electronics | ESA |
| Dish and Feed for HGA | GE |
| Elec. Power/Thermal Control Elect. | P-E |
| FHST Light Shade | Bendix |
| Faint Object Camera | Dornier |
| Faint Object Spectrograph | MMC |
| Fine Guidance Electronics | Harris |
| Fine Guidance Sensor | P-E |
| Fixed Head Star Tracker | Ball/Bendix |
| Focal Plane Assembly | P-E |
| Forward Latch, Solar Array | LMSC |
| High Resolution Spectrograph | Ball Brothers |
| High Speed Photometer | Univ. of Wis. |
| Hinge, Aperture Door | LMSC |
| Hinge, High Gain Antenna | LMSC |

| | |
|--|--------------------|
| Image Dissector Camera Assembly | P-E |
| Instrument Control Unit | LMSC |
| Interconnect Cables | LMSC/P-E et al. |
| Latch, Aperture Door | LMSC |
| Latch, High Gain Antenna | LMSC |
| Low Gain Antenna | LMSC |
| MA Transponder | Motorola |
| Magnetic Torquer | Ithaco/Bendix |
| Magnetic Sensing System | Schoenstadt/Bendix |
| Mechanism Control Unit | LMSC |
| Metal Matrix Mast | DWA/LMSC |
| Multilayer Insulation | LMSC/P-E |
| Off Load Device | ESA |
| Optical Telescope Assembly | P-E |
| Optical Control Electronics | P-E |
| Oscillator | Frequency Elect. |
| Photomultiplier Tube Electronics | P-E |
| Pointing Safemode Electronics Assembly | Bendix |
| Power Control Unit | LMSC |
| Power Distribution Unit | LMSC |
| Primary Deployment Mechanism | ESA |
| Primary Mirror Assembly | P-E |
| RF Multiplexer | Wavecom |
| RF Switch | Transco |
| RF Transfer Switch | Transco |
| Rate Gyro Assembly | Bendix |
| Reaction Wheel Assembly | Sperry |
| Retrieval Mode Assembly | Northrop/Bendix |
| Rotary Drive | Schaeffer |
| SAD Adapter | ESA |
| SI C&DH | Fairchild/IBM |
| SSA Transmitter | Cubic |
| Science/Engineering Tape Recorder | Odetics |
| Secondary Deployment Mechanism | ESA |
| Secondary Mirror Assembly | P-E |
| Sensor Electronics Assembly | P-E |
| Solar Array Blanket | ESA |
| Solar Array Drive | ESA |
| Solar Array Drive Electronics | ESA |
| Star Selector Servo | BEI |
| Temperature Sensor | LMSC/P-E |
| Thermostat/Heater | LMSC/P-E |
| Umbilical Drive Unit | Sperry |
| Waveguide | LMSC |
| Wide Field/Planetary Camera | JPL |

3.0 SUPPORT SYSTEMS MODULE (SSM)

The SSM supplies a means by which the entire integrated ST is structurally supported while making available all the required services to support a typical ST mission. The SSM includes all structures, equipment and subsystems to support ST mission operations excluding the OTA, OTA equipment section, Scientific Instruments, and the SI C&DH. The SSM subsystems are shown in Figure 3-1.

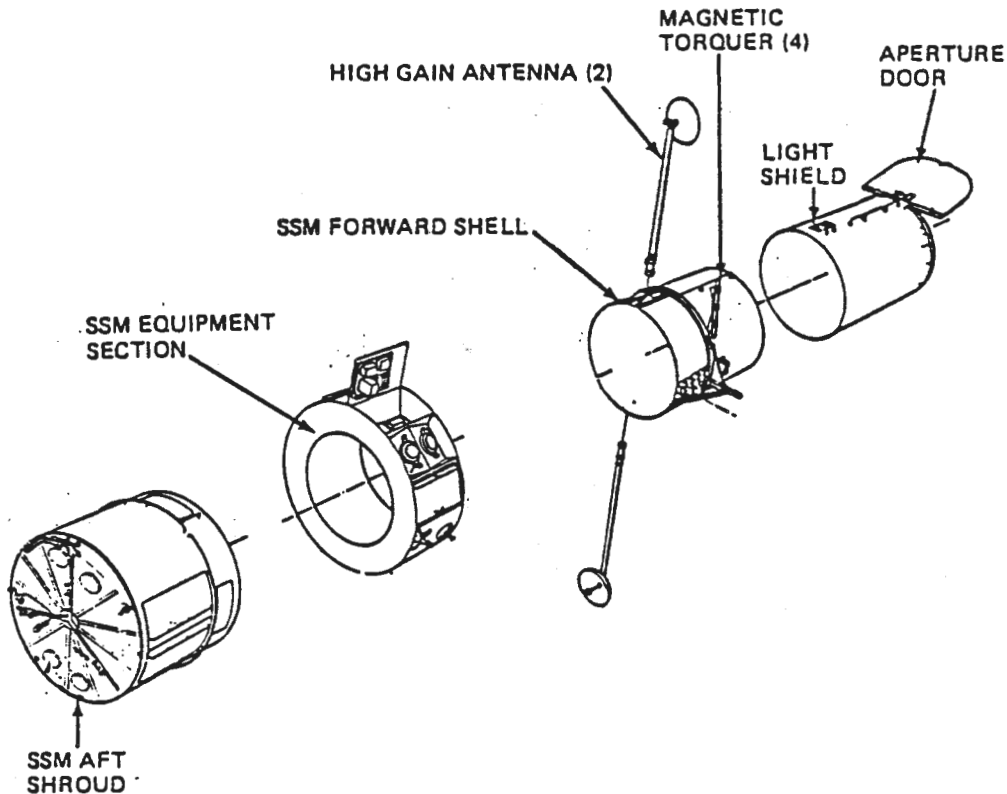

Figure 3-1 ST Support Systems Module Design Features

The SSM provides structural support, thermal control, electrical power, communications, data management, and pointing control in support of the OTA, OTA equipment section, SIs and SI C&DH. Provisions are made in the SSM for on-orbit maintenance and planned SI replacements by Extravehicular Activity (EVA) crewman while the ST is attached to the Space Shuttle Orbiter. The SSM consists of the following subsystems which are described in subsequent paragraphs:

- 3.1 Structures and Mechanisms Subsystem (S&M)
- 3.2 Instrumentation and Communications Subsystem (I&C)
- 3.3 Data Management Subsystem (DMS)
- 3.4 Pointing Control Subsystem (PCS)
- 3.5 Electrical Power Subsystem (EPS)
- 3.6 Thermal Control Subsystem (TCS)
- 3.7 Safing System (SS)

3.1 Structure and Mechanisms (S&M) Subsystem

The S&M major structural elements are Aperture Door, Light Shield, Forward Shell, SSM Equipment Section, and Aft Shroud/Aft Bulkhead. The inboard and outboard profile of the ST is illustrated in Figure 3-2 to show their relative location and design features.

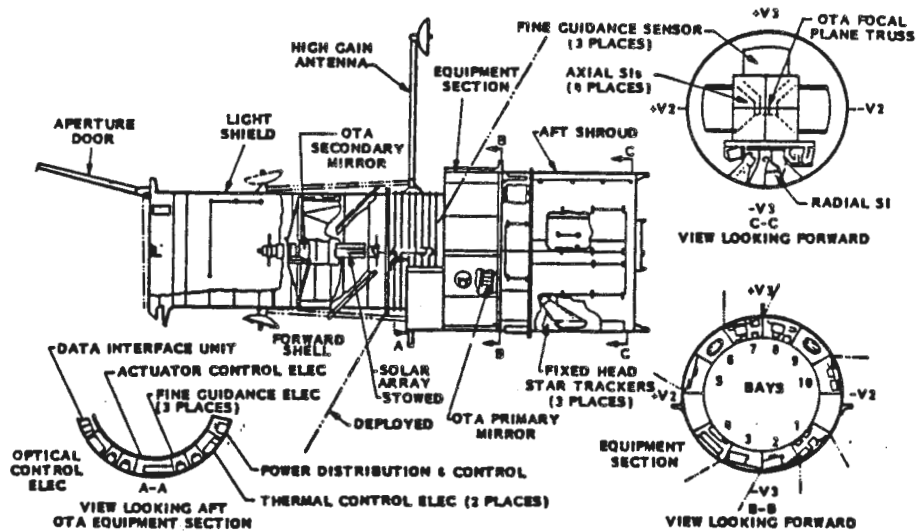

Figure 3-2 ST Inboard/Outboard Profile

The mechanisms excluding SA (Figure 3-3) are a group of devices including latches, hinges, and rotary drives which perform a number of functions upon command and in some cases automatically because of external stimuli. All devices (except the antenna gimbal drive assembly) are electrically internally redundant to the maximum extent practical, designed for manual override in case of failure, and are controlled by the mechanisms control unit. All driven hinges and latches use the same rotary drive mechanism.

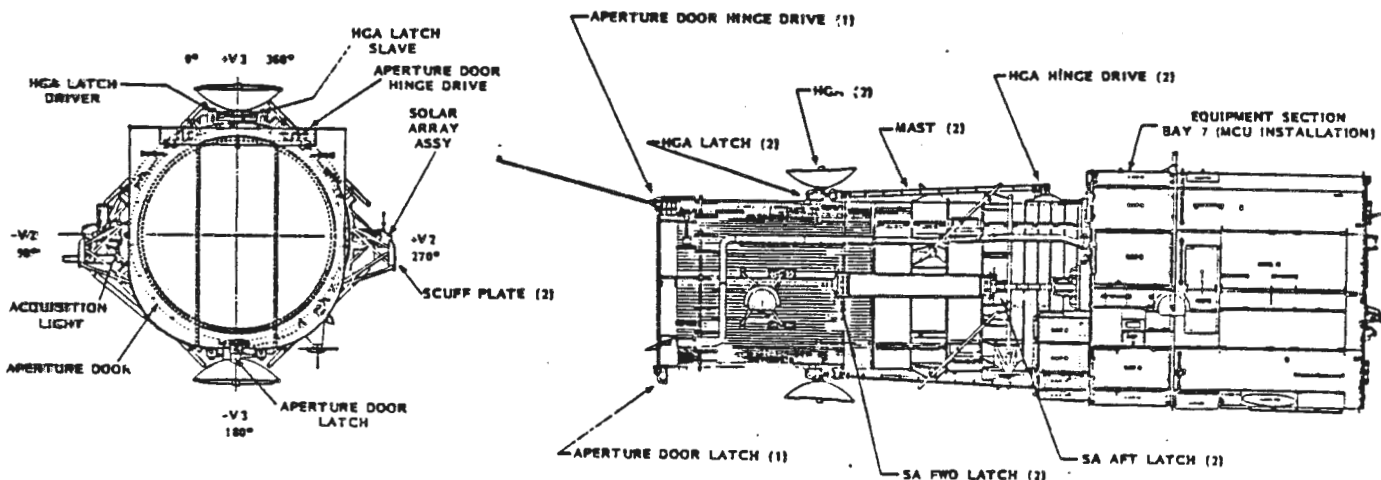

Figure 3-3 Mechanisms Located on ST

3.1.1 Aperture Door (AD)

The SSM AD (Figure 3-4) is approximately 120 in. in diameter and is constructed of:

- 0 6061-T6 AL facesheets, (0.012 in. thick)
- 0 5052 AL Honeycomb core, (1.46 in. thick)
- 0 Heavier core near hinges and latch (0.25 in. cells), 3.4 lb/ft³
- 0 Hinge-Line Beam machined 7075-T73511 AL
- 0 Peripheral edge closed of formed 6061-T6 Sheet, (3 Sides)
- 0 Outside of door covered with AL flexible optical solar reflector
- 0 Inside of door painted with Chemglaze Z302 overcoated with a clear silicone resin.

The Aperture Door covers the light shield opening. It assists in providing stray light suppression and contamination control. The Aperture Door is designed to meet the following requirements:

- 0 Contamination requirements of the SSM-to-OTA are in IRD STR-01.
- 0 Maximum travel full open/closed is 105.25 deg (± 0.25 deg).
- 0 Maximum travel time to close door is one minute.
- 0 Start closure when the sun line is within 35 deg of +V1 axis.
- 0 Finish closure when the sun line is within 20 deg of +V1 axis.
- 0 Fully opened, the door permits viewing within 50 deg of +V1.
- 0 Fully opened, a ± 5 deg roll shades the sun from entering.
- 0 A close command inhibit and override capability is provided.
- 0 The AD position status and redundant status monitors are provided.
- 0 Manual override wrench is provided to operate EVA open/closed.
- 0 Stray sunlight in the hinge region will be attenuated.

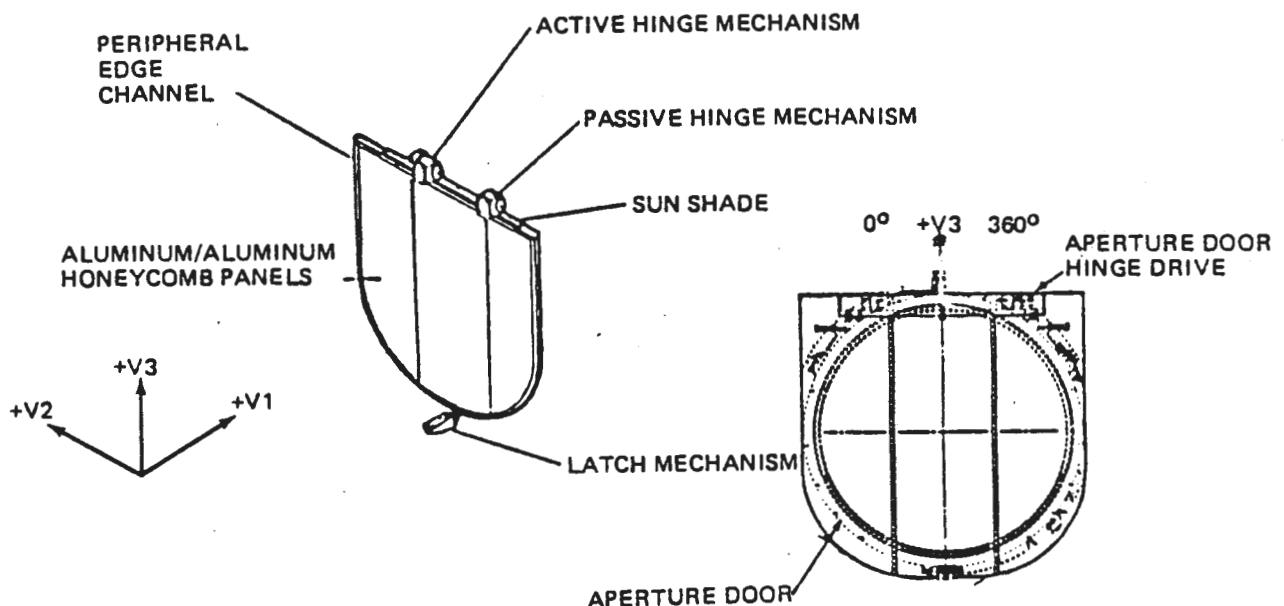

Figure 3-4 Aperture Door

31 May 1985

3.1.2 Light Shield (LS)

The SSM LS assembly (Figure 3-5) is 157.5 in. long, has an internal diameter of 120 in., and is constructed of:

- 0 Integrally stiffened skin, machined from AZ31B-H24 Mg plate
- 0 Forward end, forward SA and HGA support, and LS/FS interface rings, machined from 7075-T7351 AL rolled ring forgings
- 0 Eight internal stiffener/LS baffle support rings, stretched formed from ZK60A-T5 Mg extrusion.

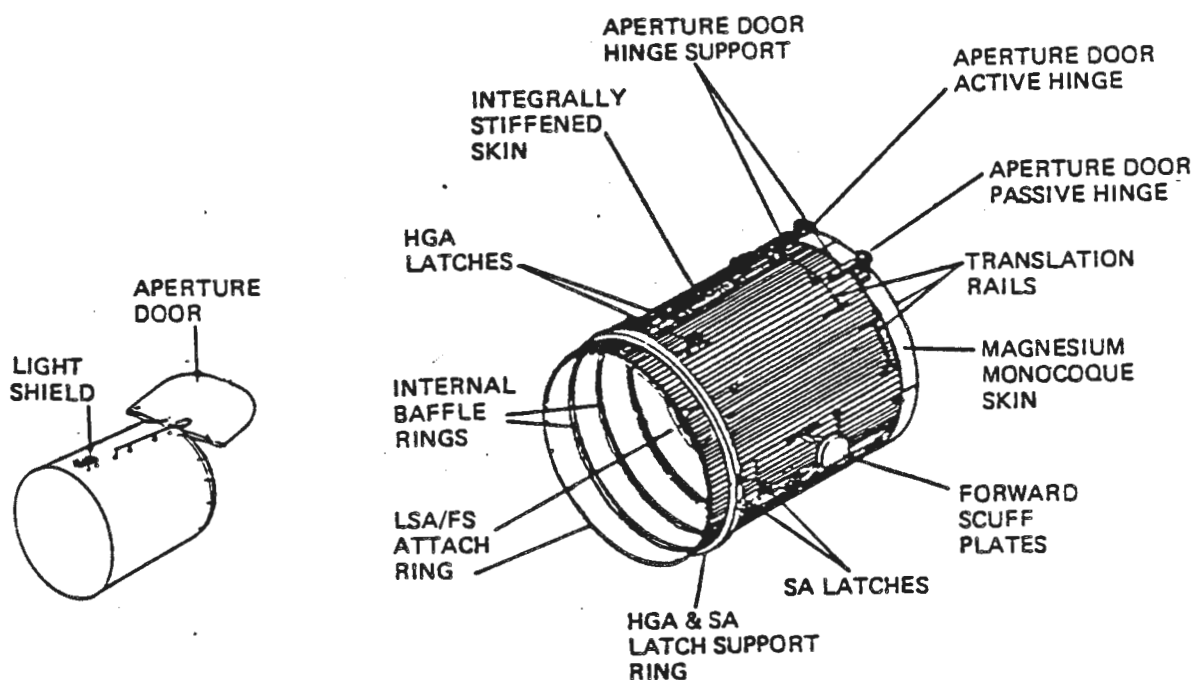

Figure 3-5 Light Shield

The LS assembly is a magnesium ring with milled and stiffened skin barrel. The forward section from Station 596.3 to Station 608.5 is a monocoque shell with the remaining portion to be integrally stiffened with one construction joint at Station 477. The LS contains ten internal light baffles with two different internal diameters for the suppression of stray light. Requirements for the light baffle design are specified in the SSM-to-OTA IRD STR-01. Internally, the LS is painted flat black. Externally it is covered with Multilayer Insulation (MLI) thermal blankets and supports a Low Gain Antenna and Waveguide, Coarse Sun Sensors, three axial Magnetometers, Aperture Door with latch and hinge mechanisms, Solar Array forward latches, High Gain Antenna latches, wire harness and coaxial cable, and crew systems aids, including foot restraint receptacles and handrails, translation rails, and handholds. The LS conforms to LMSC Drawing 4171555.

3.1.3 Forward Shell (FS)

The SSM FS (Figure 3-6) is stiffened with external rings and integrally machined internal longitudinal stiffeners. At Station 358.0, an external AL forged ring is used to support the forward trunnion. The 121.2 in. diameter, 156-in. long FS is constructed of:

- 0 Integrally stiffened skin, machined from 7075-T7351 AL plate.
- 0 Forward (FS/LS) and aft (FS/ES) interface ring, aft SA support, and forward trunnion support rings, machined from 7075-T7351 AL extrusion
- 0 Seven external stiffener rings, extrusion formed from 6061-T6511 Al.

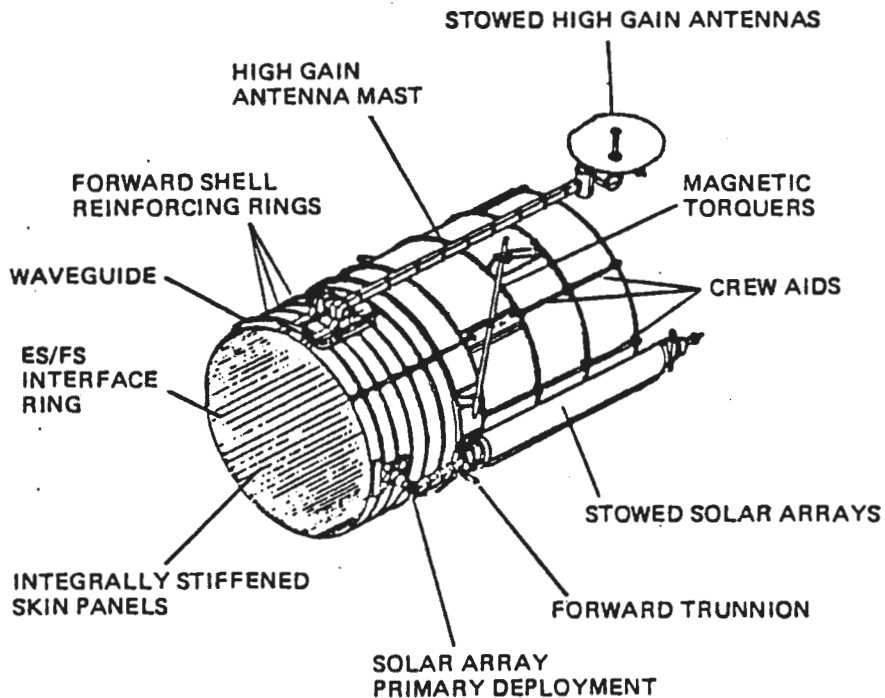

Figure 3-6 Forward Shell

The trunnion mounts through a spherical bearing system and is supported in the V3 (vertical) axis with load carrying tubular members. The FS provides the structural members for mounting four Magnetic Torquers 90 deg apart. Structural provisions for mounting the Solar Array wings and aft latches are provided on the V2 axis and for the High Gain Antenna masts on the V3 axis. The Solar Array wings and High Gain Antenna masts have the capability of being manually jettisoned. The external surface of the FS is covered with MLI thermal blankets. Structural rings are external to minimize internal contamination and to provide maximum dynamic clearance for the OTA. The Low Gain Antenna and High Gain Antenna mast waveguide is externally mounted and will traverse the FS. The FS provides support for a single remote manipulator system grapple fixture and also provides crew system aids, including foot restraint receptacles and handrails, translation rails, and handholds. The FS conforms to LMSC Drawing 4171568.

3.1.4 Equipment Section (ES)

The SSM ES (Figure 3-7) has an outside diameter of 168.0 in. and an internal barrel section diameter of 120.6 in. and is 61.25 in. long and is constructed of:

- 0 Integrally stiffened frame panels, machined from 7075-T73 AL
- 0 Integrally stiffened inner barrel, machined from 7075-T73 AL
- 0 Radial rib shear panels, machined from 7075-T73 AL sheet/plate
- 0 Ten flat honeycomb cores and two curved stiffened panel doors.

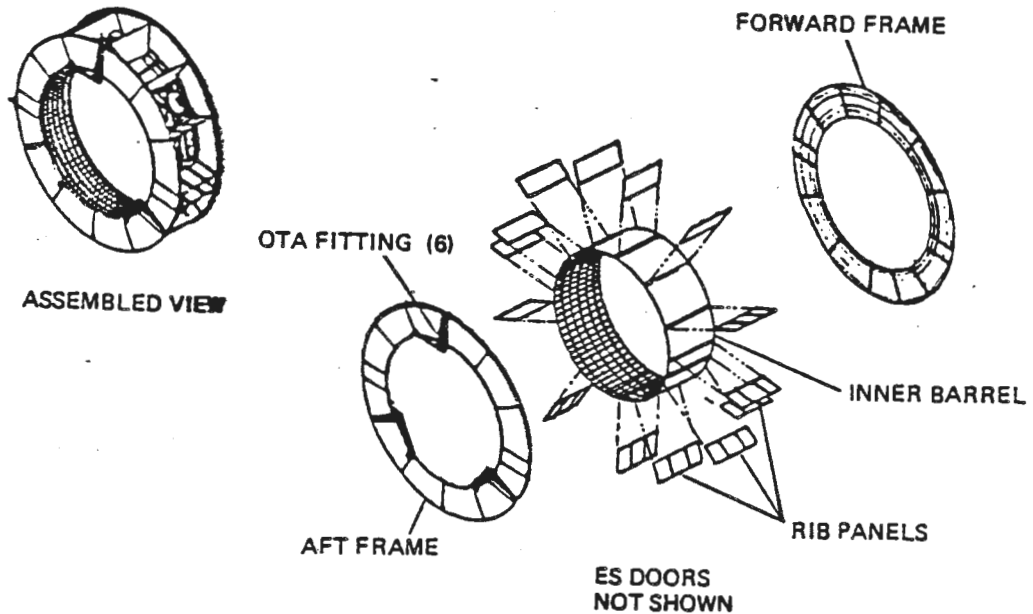

Figure 3-7 SSM Equipment Section

Radial shear webs from the inner shell to the outer diameter separate the ES into 12 bays, two of which provide the structure supporting the two aft trunnions. The trunnions at Station 240.0 will carry fore and aft (V1 axis) as well as vertical (V3 axis) loads. Provisions are provided for support of a keel fitting at Station 240 (+V3 axis). Eight of the remaining ten bays have external flat honeycomb hinged doors; the remaining two bays contain the four Reaction Wheel Assemblies and have only a thermal control enclosing surface or cover. Subsystem equipment is placed on the doors and the inner barrel outer surface including the solar array electronics and the SI C&DH. Thermal shields are mounted on external standoffs from some of the doors. OTA attach points are provided by a six-point mount system on the ES Aft Bulkhead in accordance with the OTA/SSM ICD-01.

The SSM ES is composed of ten equipment bays. The ES layout is shown on Figure 3-8 for definition of the ES component locations. The ES provides two government furnished equipment solar array diode boxes on the forward (+V1) end. One located on the -V2 axis and the other on the +V2 axis. On-orbit maintenance of equipment in the ES is achieved through a Orbital Replaceable Unit (ORU) concept. Provisions are made for crew aids, manual power turn-off

31 May 1985

during maintenance, ground test plugs, and air conditioning during ground operations. The ES conforms to LMSC Drawing 4171576.

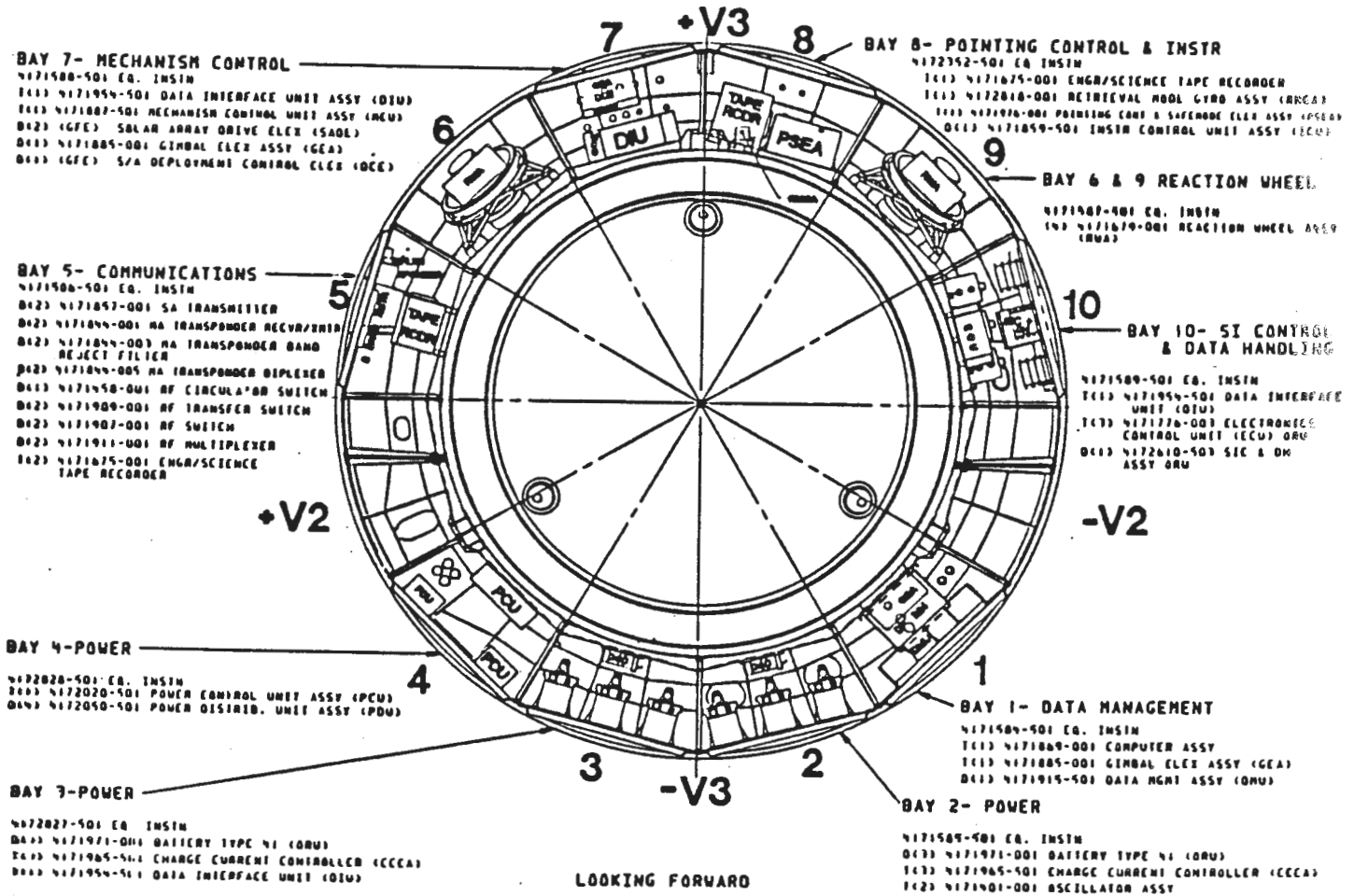

Figure 3-8 Equipment Section Component Locations

The typical SSM ES Bay consists of reinforced rib panels, ES forward and aft bulkheads, and inner barrel rings. The equipment is mounted in the tunnel structure and on the panel door. Each Bay is vented through four EMI sealed vents in the door panel. Each Bay is constructed to support the equipment such as the ORUs mounted in six Bays.

For example: the reaction wheels are located in the SSM ES Bays 6 and 9. There are two Reaction wheels in each bay that are held down by six bolts on each tab. Each reaction wheel assembly truss consists of two rings and 16 tubular legs. The truss material is 6061-T6 aluminum and is mounted on a beam running fore/aft of material 7075-T73 aluminum.

3.1.5 Aft Shroud (AS)

The SSM AS (Figure 3-9) is a cylindrical structure with an inside diameter (at the inside of the outer skin) of 168.0 in. with a length of 138.0 in. and is constructed of: (a) integrally stiffened skin, machined from 7075-T7351 AL plate; (b) unstiffened skin, AZ31B-H24 Mg sheet; (c) forward (AS/ES) interface ring and four door sill rings, machined from 7075-T7351 AL rolled ring forging; (d) five stiffener rings and door frame ring segments stretch formed from 7075-T7351 AL extrusion; (e) eight external longerons machined from 7075-T7351 AL bar; and (f) Eight internal longerons and door frame longitudinal members, 7075-T7351 AL extrusion.

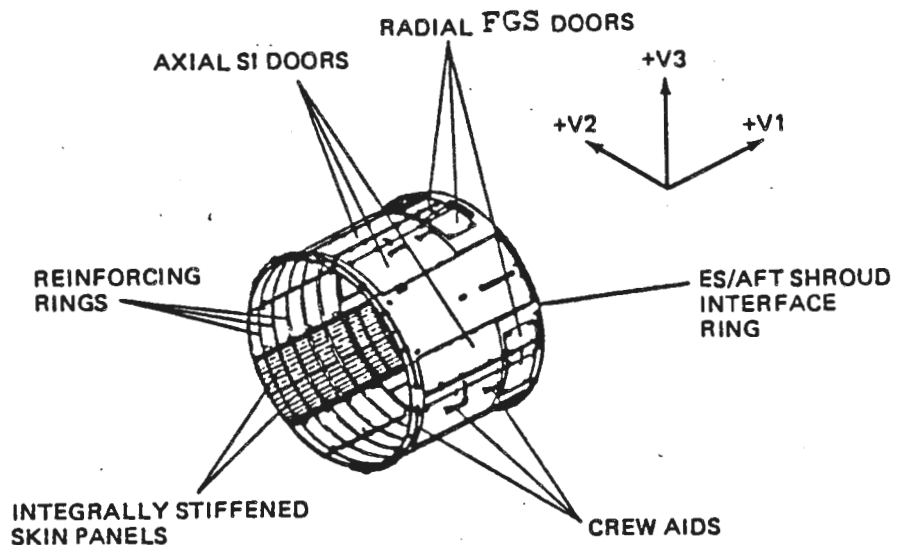

Figure 3-9 Aft Shroud

The AS provides an opening for the installation of the Wide Field/ Planetary Camera (WF/PC) including its external radiator. Doors also provide adequate access by Extra Vehicular (EV) crew for axial Scientific Instruments (SIs), Fine Guidance Sensors (FGSs) and Rate Sensing Units (RSU) changeout. Longitudinal and circular EVA rails, internal translation handrails, internal light provisions, and foot restraint attach points are provided to support crew system requirements. Also provided is the Low Gain Antenna assembly, waveguide, and Coarse Sun Sensors. A non-mechanical seal is provided between the WF/PC external radiator and the AS which meet the light tight requirements. A continuous dry nitrogen purge capability are provided to the SIs to prevent contamination, commencing with their installation and ending when the orbiter doors are closed.

The Aft Bulkhead (see Section 3.1.6) is also part of the AS and closes the end of the ST AS.

3.1.6 Aft Bulkhead (AB)

The SSM AB (Figure 3-10) is part of the AS and closes the 168 in. diameter Aft Shroud assembly with a flat honeycomb bulkhead which is attached through ring segments and is constructed of:

- o 7075-T6 AL, honeycomb, 2 in. thick with 0.25-in. cells
- o Three radial beams to secure flight support system pins, from 6061-T651 AL, and bonded into the honeycomb panels
- o Forward locating ring of stretch-formed 6063-T5 extrusion
- o Aft closure ring of stretch-formed 7075-T73511 extrusion.

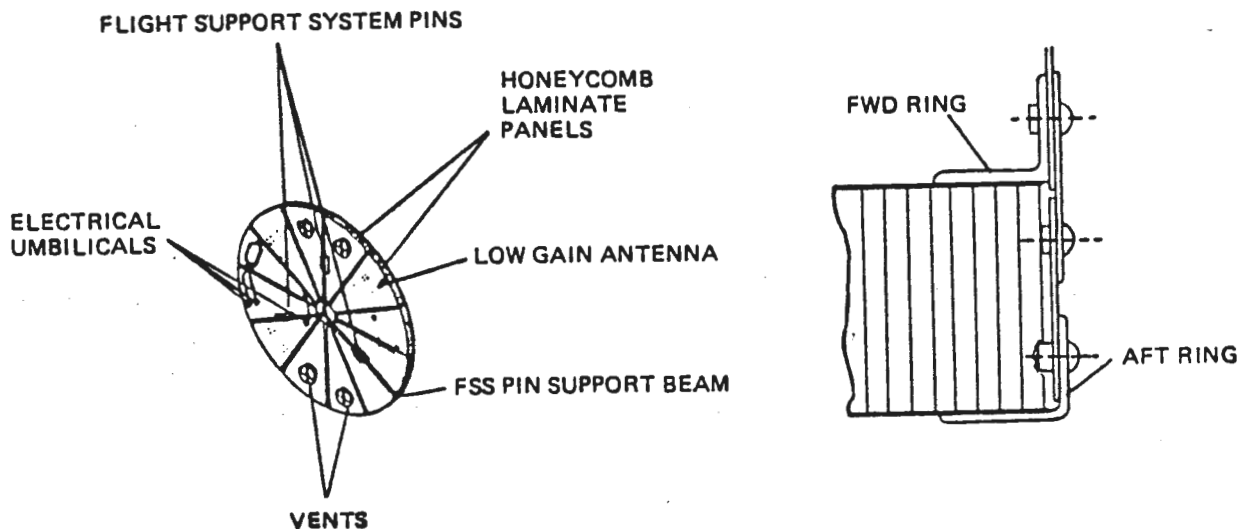

Figure 3-10 Aft Bulkhead

The interface structure for the Flight Support System (FSS) is provided, and includes three berthing pins, an umbilical connector, and an alignment target. Provisions are made in the aft shroud for installation of an SI cryogenic vent system. The vent outlet is located in the aft shroud AB and meets the light tight and Electromagnetic Interference (EMI) shielding requirements. To achieve the purge, intake Quick Disconnect (QD) fittings are supplied at the AB and flexible tubes carry the purge gas from the intake fittings to QD fittings on three of the axial SIs and the WF/PC. Provisions are made for stowing the nitrogen purge lines during SI changeout. Ducting through the aft bulkhead does not permit light leaks in excess of 1×10^{-5} lumens per square meter.

3.1.7 Mechanisms

Mechanisms are a group of devices that perform upon command by the Data Management System (DMS), and in some cases automatically because of external stimuli. All devices are redundant internally, designed for manual override in case of failure and are controlled by a Mechanisms Control Unit (MCU) as directed by the DMS. The MCU contains internally redundant electronics to control the motors, latches and hinge mechanisms of the following subsystems: Solar Array (SA), High Gain Antenna (HGA), and Aperture Door (AD).

The Mechanisms Block Diagram (Figure 3-11) presents the mechanisms contained in the subsystem and their associated equipment designators. Mechanisms are provided to secure the deployable assemblies during the Shuttle launch phase. After the ST is deployed by a Remote Manipulator System (RMS), the Shuttle backs away to a safe distance and the ST assemblies are unlatched and deployed to the mission configuration by ground command. In the retrieval phase, these assemblies are returned to their original configuration and latched, again by ground command.

The deployable assemblies consist of the AD hinge drive and latch, two HGA hinge drives and four latches, and two SA latches on each wing. Each mechanism contains end-of-travel Telemetry Latching Mechanism (TLM) microswitches.

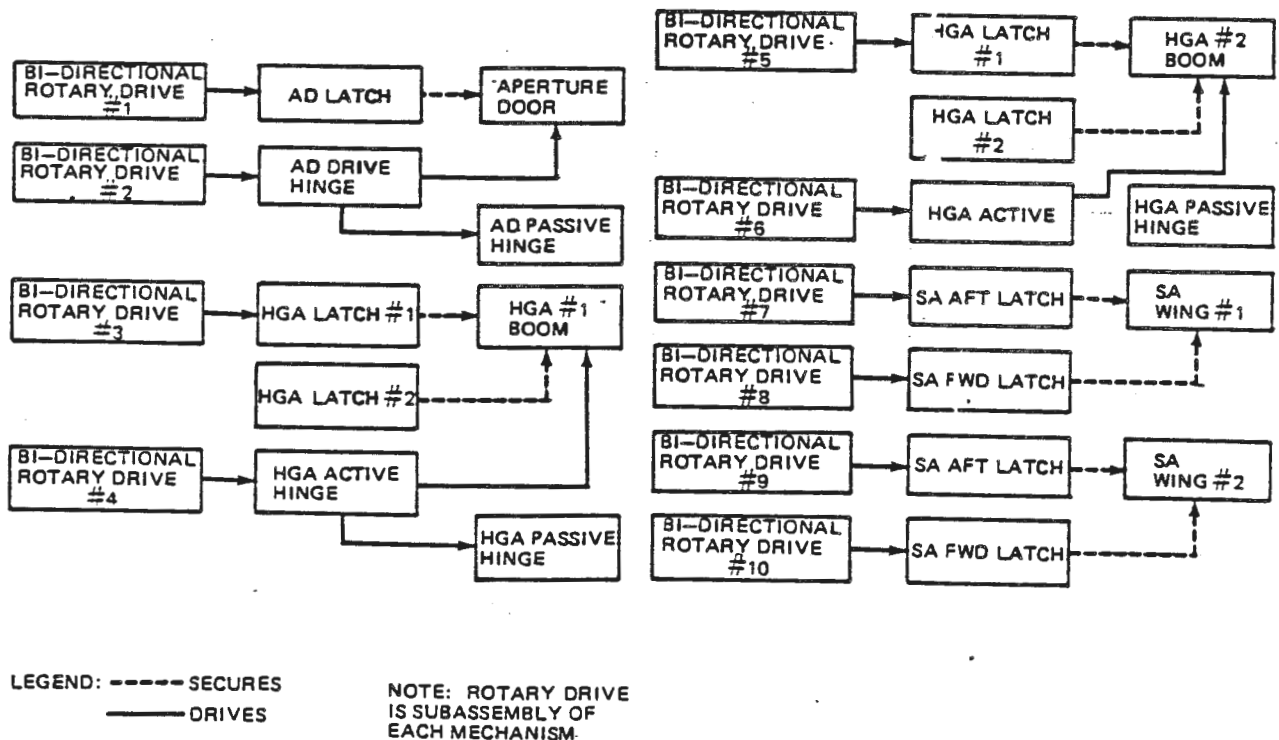

Figure 3-11 Mechanisms Block Diagram

3.1.7.1 Latch

The latch mechanisms (Figure 3-12) secure, release and relatch deployables on the ST. Each latch mechanism is a mechanically preloaded device composed of a four-bar linkage driven by a rotary drive actuator. The latch mechanisms secure the SA wings, the HGA and AD during ST deployment and retrieval. The latches are normally operated with a rotary drive actuator; however, contingency manual operation during EVA is also available. A total of nine latches are utilized as follows: two for each of the two HGA, two at the SA aft position, two at the SA forward position and one for the AD. The HGA, aft SA latches and AD latches are identical in design. The HGA latches are designed slightly different from the others, since one latch with its Rotary Drive Actuator (RDA) drives a slave latch via an interconnecting drive shaft (see Figure 3-17).

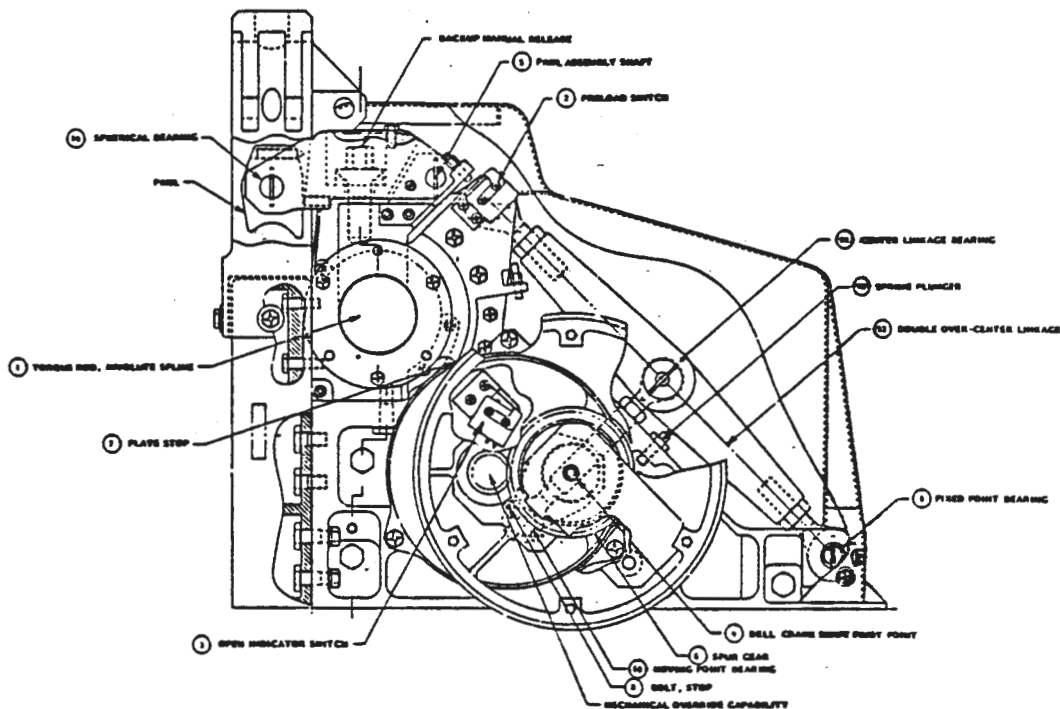

Figure 3-12 Latch Assembly

A driving spur gear provides a 3.2:1 mechanical advantage to aid the astronaut in manually operating the latch. The rotary drive actuator, with its magnetic detent in the stepper motor acting through an Harmonic Drive Gear Head (speed reducer), creates a resistance to unpowered rotation. Torque applied to the output shaft will cause it to backdrive through the gearhead. A 7/16-in. hex fitting (to accept a wrench on the pinion shaft) provides access for the astronaut to manually operate the latch. The magnetic detent in the stepper motor also provides the holding feature for the latch in either the open or closed position. In case the astronaut is unsuccessful in overriding the latch, the pawl arm can be released and rotated to release the latch.

3.1.7.2 Hinge Drive

A hinge drive (Figure 3-13) is used to open and close the AD and deploy each of the HGAs. The figure shows a cross section of the hinge drive assembly. A passive drive provides mechanical balance and an additional bearing support. Bearings are identical in the active and passive drives; each consists of two sets of primary bearings and spherical bearing in active redundancy. The active hinge is driven by a rotary drive actuator.

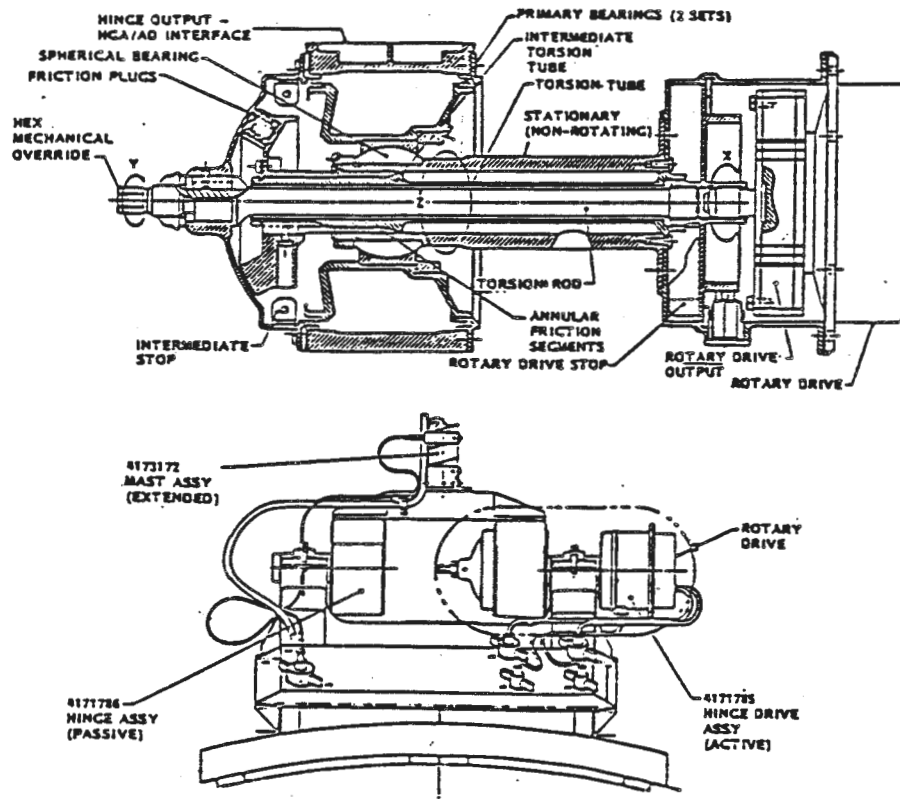

Figure 3-13 Typical Hinge Assembly

The primary astronaut override method in the case of a drive failure is to manually deploy or retract the HGA, or open and close the AD by overcoming the forces in the hinge. The backup procedure is to mechanically turn the mechanism with a hex wrench at the point shown.

The AD is opened as part of the deployment sequence and remains open during the mission. It is closed automatically when the pointing system detects sun presence. In the retrieval phase, the door is closed by ground commands.

The two HGAs are erected as part of the deployment sequence. Mission success requires the deployment of at least one HGA; however, the increased recording time with one HGA may reduce tape recorder life by a limited amount. In the retrieval phase, the HGAs are returned to the stowed position by ground command. Both HGAs and the AD can be removed and jettisoned in case of trouble during retrieval phase.

3.1.7.3 Rotary Drive Actuator (RDA)

The RDA (Figure 3-14) is a compact, coaxial design, featuring a unique, small angle (1.5 deg), permanent magnet stepper motor driving the output through a harmonic drive speed reducer (ratio of 200:1). The motor is a three-phase, six-state, wye-connected stepper containing two physically and electrically isolated redundant stator windings. Each of the three-phase winding configurations is coded into six discrete operating states. Reversing the code sequence reverses the direction of rotation. The bi-directional RDAs are utilized to deploy the HGA and to open/close the AD. Other bi-directional RDA features are:

- 0 Output step angle: 0.0075 deg
- 0 Step rate: 0 to 300 steps/sec
- 0 Output torque: > 750 in-lb
- 0 Unpowered holding Torque: > 100 in-lb
- 0 Peak power: 12.0 W
- 0 Operational controlled temperature range: -30°F to +160°F.

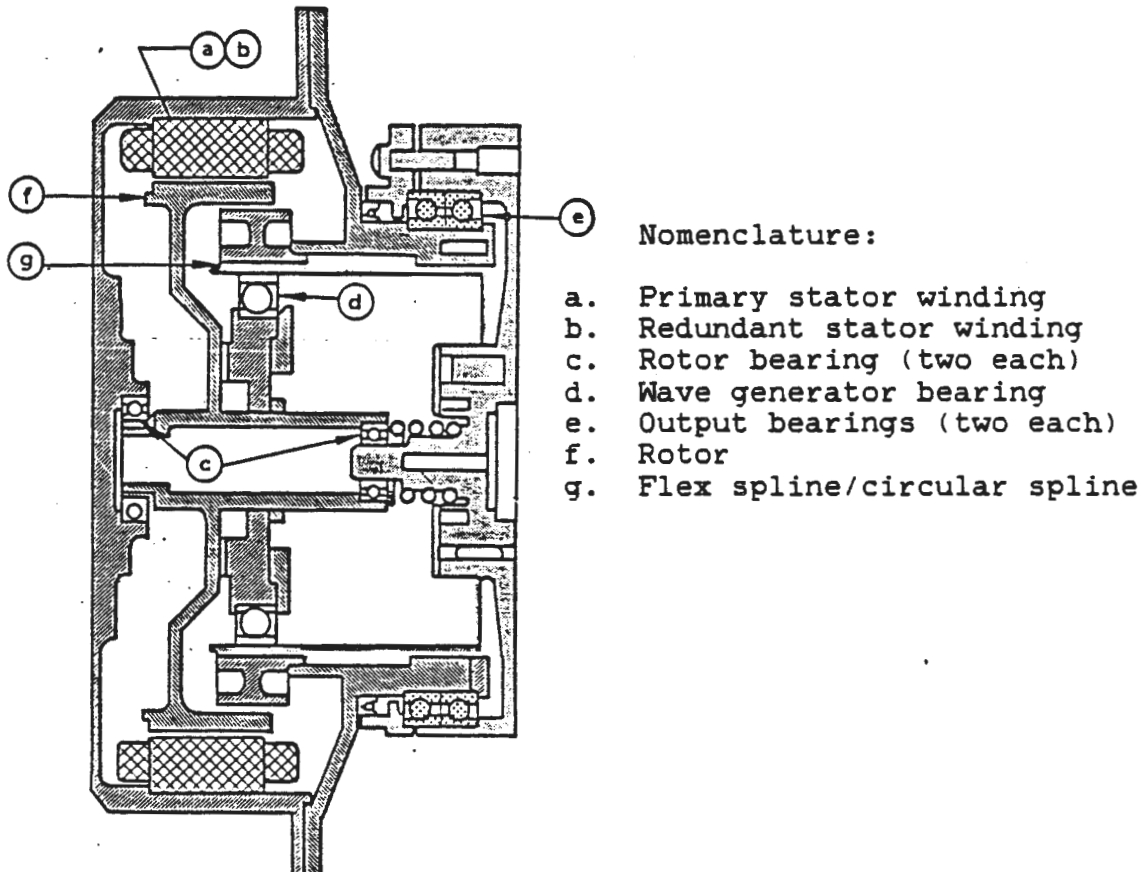

Figure 3-14 Rotary Drive Actuator

The RDA provides the mechanical drive for each mechanism located at: seven of the nine latches, each of the two HGA active hinges and the AD drive hinge. Each of the ten RDAs is electrically driven by a dedicated channel in the Mechanism Control Unit (MCU).

3.1.7.4 Two-Axis Gimbal (TAG)

Each High Gain Antenna (HGA) dish is attached to a boom through a Two-Axis Gimbal (TAG). The TAG (Figure 3-15) general capabilities were established for the Spectro-Mirror Mechanism HGA application. The gimbal range is ± 110 deg with mechanical stops at ± 112 deg. The TAG has a 20 oz-in. torque for electronically controlled rates to 30 deg/min. The command torque linearity is within 25 percent deviation. This linearity was difficult to verify at low torque levels. The mechanical pointing alignment is to be within 0.1 deg. The HGA system alignment based on assembly machining is better than 0.05 deg. The resolver accuracy is within four arcmin over ± 120 deg range (-45°C to 40°C). The ripple is less than 5.6 percent of maximum. Features of the HGA TAG are:

- 0 Weight 10.5 lb, each axis
- 0 Rotational freedom ± 110 deg
- 0 Dual redundant configuration
- 0 Integral thermal control
- 0 DC brushless torque motor
- 0 Life > 5 years
- 0 Passive film lubricant, KG-80
- 0 Electrical and RF interfaces provided.

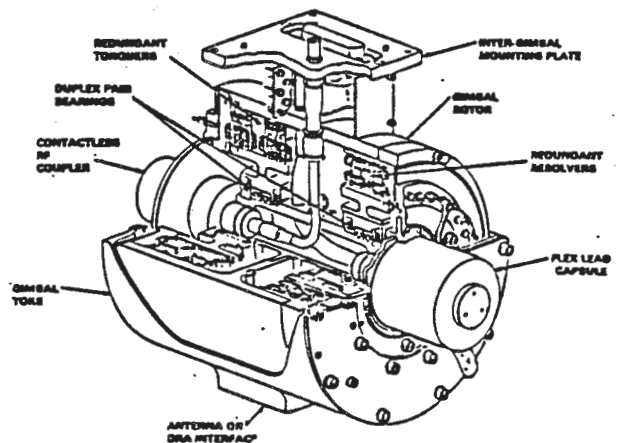
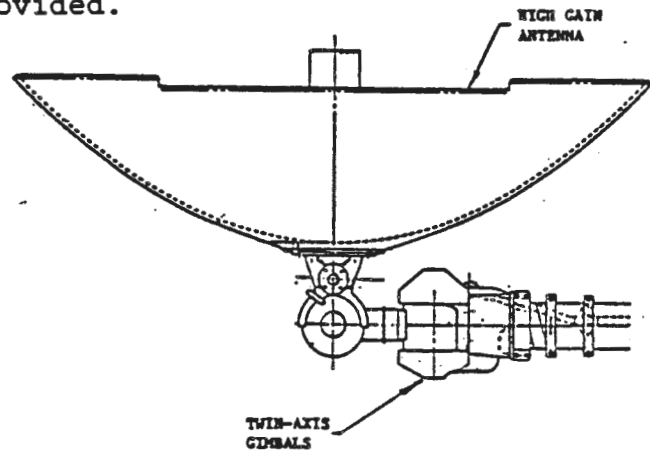
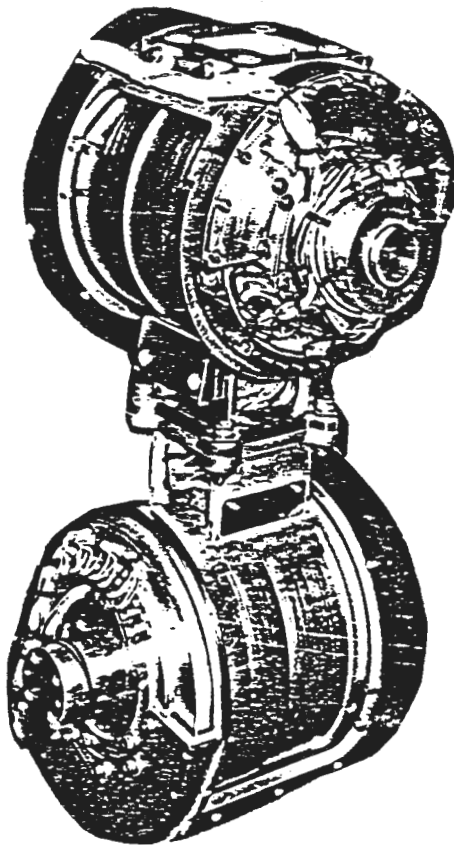

Figure 3-15 Two Axis Gimbal (TAG)

3.1.8 Solar Array (SA) Latch Mechanisms

Mechanisms for securing two SA systems (Figure 3-16) are installed on the SSM LS/FS.

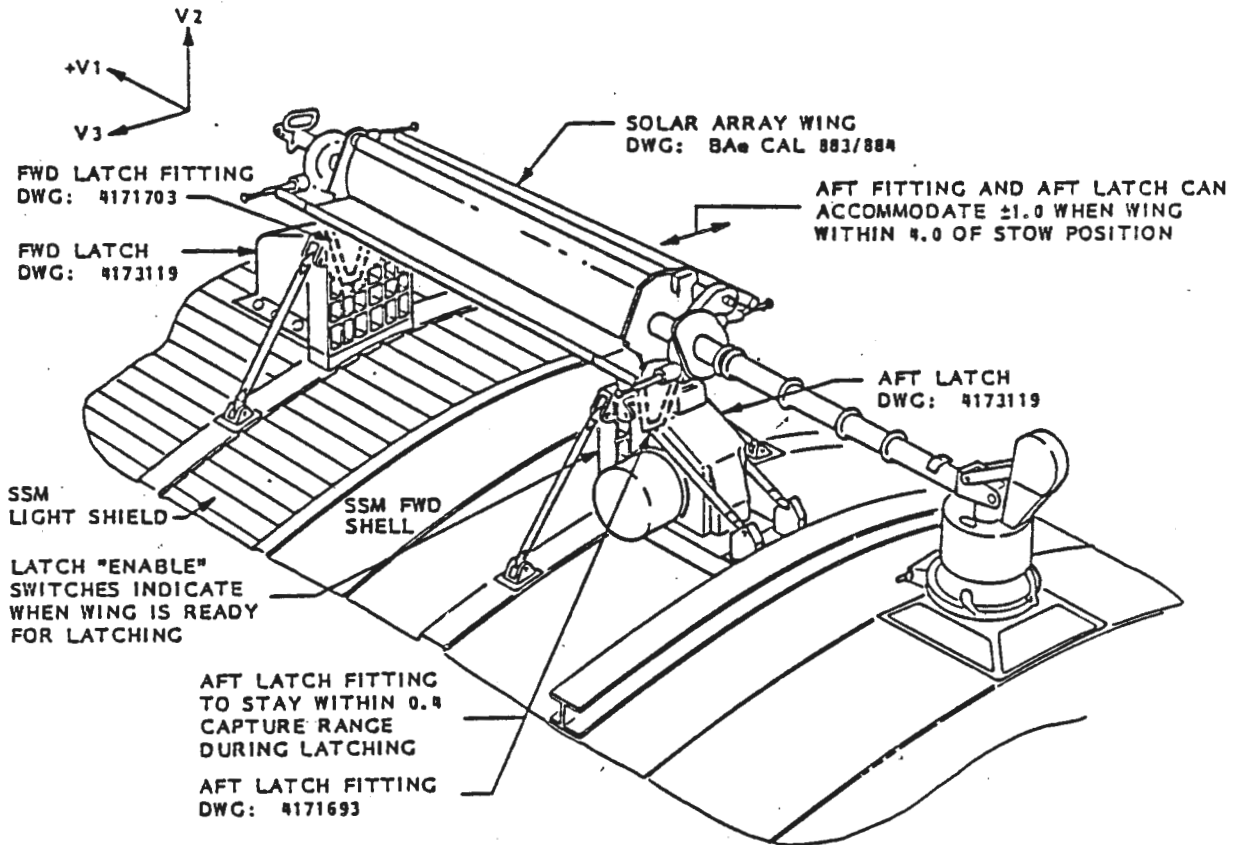

Figure 3-16 Solar Array Latch Mechanisms

The latch mechanisms secure the SA wings until each is deployed and after resecuring at the time of ST retrieval. The SA Latch features are:

- 0 Preload: 2750 +275/-0 lb
- 0 Operational rate: 1.35 deg/sec
- 0 Time to latch or relatch: $\approx 2\frac{1}{2}$ min
- 0 Redundant rotational bearings
- 0 EVA manual override capability
- 0 Rotary actuator at -30°F or above with heater/thermostat
- 0 Aft latch reacts loads in three axes
- 0 Forward latch reacts loads in two axes (V2 and V3 axis)
- 0 Aft latch must be latched before the forward latch
- 0 Forward latch must be unlatched before the aft latch.

31 May 1985

3.1.9 High Gain Antenna (HGA) Mechanisms

The two HGA systems (Figure 3-17) are installed on the SSM LS/FS.

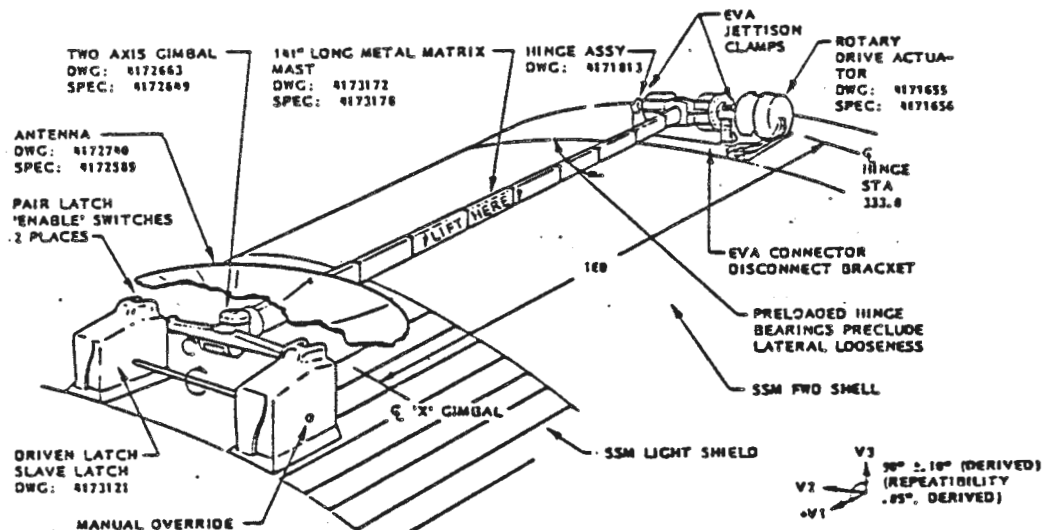

Figure 3-17 High Gain Antenna Mechanisms

Each subsystem consists of an antenna, two-axis gimbal TAG antenna pointing system, mast, deploy/retract/jettison system, and latches. The deployment hinge support mount is aligned through a three point adjustable attachment to the FS. Each antenna and pointing assembly is mounted on a mast designed in accordance with RF waveguide and structural stiffness requirements. Each HGA is stowed against the Forward Shell (FS) structure (one each at +V3 and -V3 axis) while in the Shuttle bay and deployed upon command (and retracted for ST retrieval) by a reversible motor-driven hinge mechanism. Each mast, with its antenna and gimbal drive assembly, can be manually jettisonable. Two foot restraints permit hinge area and latch area access for manual override.

The HGA hinge features are:

- 0 Deployed preload: 80 +70/-30 in-lb
- 0 Deploy/Stow rate: 0.23 deg/sec
- 0 Time to deploy or restow: ~ = seven minutes
- 0 Capable of manual deploy/restow, preload at deploy position
- 0 More angular travel commanded to hinge actuator than needed
- 0 Deploy stop repeatability demonstrated to 0.033° (two arcmin.)
- 0 Redundant rotation bearings
- 0 Switches indicate deployed or stowed position.

The HGA latch features are:

- 0 Preload: 865,+87/-0 lb each latch
- 0 Operational rate: 1.35 deg/sec
- 0 Time to latch or relatch: ~ = 2 ¼ min
- 0 Redundant rotational bearings
- 0 EVA manual latch override capability - both at the same time
- 0 Rotary operates at -30°F or above with heater/thermostat.

3.1.10 Aperture Door (AD) Mechanisms

The AD (Figure 3-18) is driven by a single hinge mechanism and drive motor and will open or close upon command. Signals from the Coarse Sun Sensor indicating that the pointing azimuth of the ST is approaching the sun will cause the Mechanism Control Unit (MCU) to power the mechanism to close the door. The mechanism mounts on the forward end of the LS (LMSC Drawing 4171567).

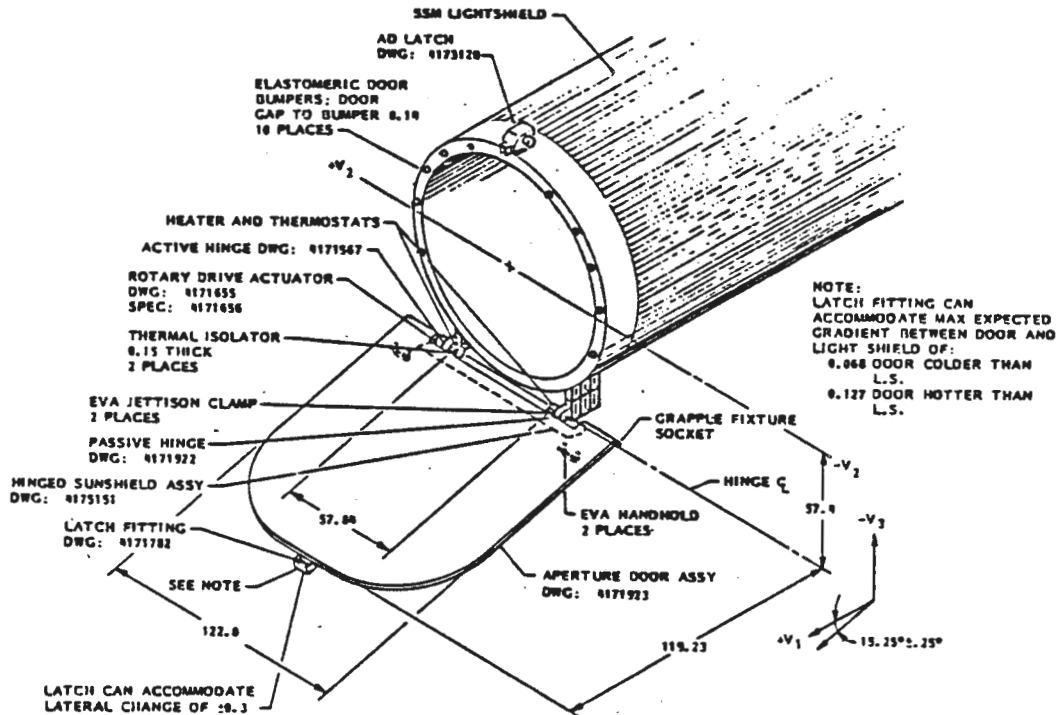

Figure 3-18 Aperture Door Mechanisms

The AD hinge features are:

- 0 Deployed preload: 80 +70/-30 in-lb.
- 0 Open/close rate: 2.25 deg/sec and 0.23 deg/sec
- 0 Time to open or close door < 1 min
- 0 Capable of manual close/open, manual preload at deploy position
- 0 More angular travel commanded to hinge actuator than needed
- 0 Open stop repeatability demonstrated to 0.033 deg (two arcmin)
- 0 Redundant rotational bearings
- 0 T/M potentiometer indicates door position, < three min. of door travel
- 0 Rotary actuator at -30°F or above with heaters /thermostats
- 0 Hinge bearings at -80°F or above with heaters/thermostats.

AD latch features are:

- 0 Preload: 770 +77/0 lb
- 0 Operational rate: 1.35 deg/sec
- 0 Time to latch or relatch: ~ = 2½ min
- 0 Redundant rotational bearings
- 0 EVA manual override capability
- 0 Rotary actuator at -30°F or above with heater/thermostat.

3.2 Instrumentation and Communications (I&C) Subsystem

The I&C subsystem block diagram (Figure 3-19) includes all on-board equipment required to complete the communication loop and supply signal conditioning for temperature and sensors.

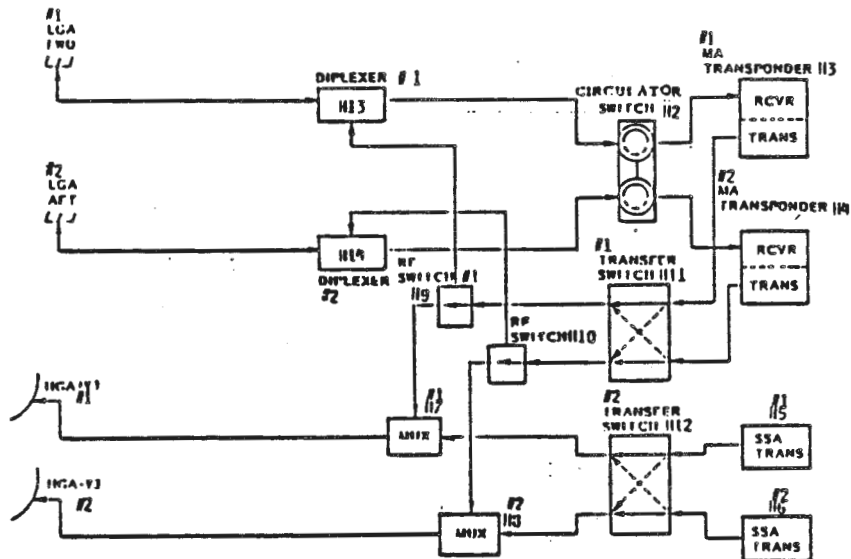

Figure 3-19 I&C Subsystem Block Diagram

The instrumentation subsystem hardware include an Instrumentation Control Unit (ICU), temperature sensors, and signal conditioning not incorporated in other subsystems equipment. The ICU provides electrical power control and signal conditioning for temperature sensors. The temperature sensors (thermistors) conform to LMSC Drawings 1621359 and 1621360.

Communication hardware in this subsystem will include S-Band Single Access (SSA) transmitters, Low and High Gain Antennas, Multiple Access (MA) transponders, RF transfer switches and multiplexer, a ferrite/stripline type circulator switch, antennas and pointing system, RF switches, coaxial cables, and waveguides. Redundant multiple access and single access links are provided.

Communication to the ST is accomplished through the MA forward link utilizing the Low Gain Antenna (LGA) system and the SSA/SSM return links utilizing the High Gain Antenna (HGA) system during normal operations and the LGA system during deployment, retrieval, and contingency operations. The receiver demodulates the discrete command and ranging channels; routes the command information to the command detector unit and the ranging Pseudo-Random Noise (PN) code to the transmitter portion of the transponder. An on-board generated ranging PN code is synchronized with the received PN code to provide ranging information for orbit determination.

3.2.1 Low Gain Antenna (LGA)

Two LGAs provided are conical spiral, Left-Hand Circular Polarized (LHCP) antenna with a maximum 3 dB axial ratio. The two antennas are mounted at opposite ends of the Spacecraft and approximately 180 deg apart. The antennas provide 95 percent spherical coverage at a minimum gain of negative one dBi. The LGA has a frequency range from 2,100 MHz to 2,300 MHz.

3.2.2 High Gain Antenna (HGA)

The HGA (Figure 3-20) is a paraboloidal antenna with Left-Hand Circular Polarization (LHCP), a specified maximum value of three dB axial ratio within one degree of the rf boresight axis. The gain is a minimum +26.4 dBi within a one degree cone about the boresight axis. The HGA transmits over the following frequencies: 2,255.5 \pm 10 MHz and 2,287.5 \pm 10 MHz. Each of two HGAs is mounted on a two-axis gimbaling system at the ends of deployable masts located on opposite sides (\pm V3 axes) of the SSM. Pointing will be controlled by the antenna pointing system gimbal and electronics. The HGA pointing system is capable of the following:

- 0 Slew rate (0.5 deg/sec nominal) in gimbal X or Y reference axis
- 0 Capable of pointing to a fixed position (RSS error < \pm 1 deg)
- 0 Provide a 20 deg boresight clearance to any ST structure except AD and SA (reposition) for any orientation of the antenna dish
- 0 ST line of sight error held < 0.0007 arcsec during HGA movement
- 0 Capable of accepting STOCC orientation commands (SSM in Safe Mode).

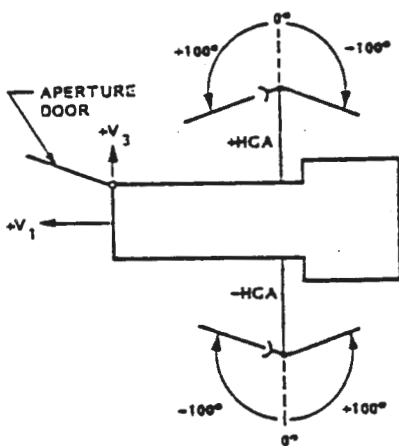

Definition of HGA X-Axis Angles

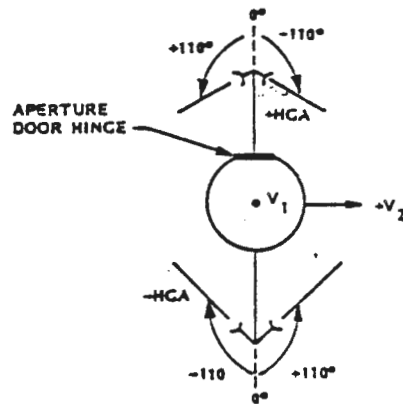

Definition of HGA Y-Axis Angles

Figure 3-20 High Gain Antenna

3.2.3 Multiple Access (MA)

The MA system utilizes two simultaneous, independent channels (I and Q) in one of three modes employing spread spectrum techniques for the transmission of real time four kbps or 32.0 kbps science and engineering data. In Modes one and two, the data in each channel are asynchronously added to an ST unique PN code prior to modulating quadrature phases of 2287.5 Mhz five watt RF carrier. In mode three, the in-phase (I) channel only is added to an ST unique PN code. Mode three is not used frequently. Engineering data may be transmitted on either the I or the quadrature phase (Q) channel at four kbps or 32 kbps data rates or on both channels simultaneously. Science data are transmitted on the I channel only. The MA system also provides a third channel for direct communications with the Ground Spaceflight Tracking and Data Network (GSTDN). This channel is utilized primarily for tape recorder playback during contingency operations, although it is capable of transmitting all ST data rates. The NASA standard transponder is a Government Specified Procurement (GSP) type. The MA transponder includes the duplexers and filter.

Each redundant transponder provided contains an S-Band receiver, command detector, and a five watt transmitter capable of TDRSS service at the TDRSS MA forward link (TDRS to ST) frequency of 2,106.4 MHz, nominal, and a return link (ST to TDRS) frequency of 2,287.5 MHz, nominal. The transponders also are able to receive command data rates of 1,000/125 bps. Ranging code coherence is provided by the transponder in its selectable mode.

3.2.4 S-Band Single Access (SSA)

The SSA system utilizes a single data channel for the transmission of real time science data, playback science data, or playback engineering data at a 1.024 Mbps rate. All data are differentially encoded, rate 1/3 convolutionally encoded and optionally periodic convolutionally interleaved during periods of RFI prior to Binary Phase Shift Key (BPSK) modulating a 2255.5 MHz 13.5 W RF carrier.

The Instrumentation Control Unit (ICU) provides signal conditioning for the ST temperature sensors. The incoming DC power is put through a regulator and then distributed to the individual sensors. The necessary resistors to condition the output of temperature sensors are contained in this box. The ICU is internally redundant with each side essentially in parallel to all of the sensors. Each sensor can be serviced by either ICU section.

3.3 Data Management Subsystem (DMS)

The DMS provides for the acquisition, processing, storage, and dissemination of all data and commands between the Communications Subsystem and all other subsystems of the ST. The DMS functions across ten major functional interfaces: Data Management Unit (DMU)/DF-224 Computer Interface, Vehicle (ST) Timing, Forward Link Commanding, Data Interface Unit (DIU), Telemetry, Data Recording, Fixed Head Star Tracker (FHST) Interface, Rate Gyro Assembly (RGA) Interface, Solar Array (SA) Interface, PSEA, and, SI C&DH.

The DMS provides the capability to accept, decode, and distribute forward link messages received via the ST communications subsystem; store time-tagged commands for subsequent distribution and execution; distribute and execute real time commands; gather, format and record/transmit ST engineering telemetry data; record/transmit science data, and perform PCS computations.

A functional block diagram (Figure 3-21) of the DMS, provides the basic functions of the DMS. Interaction of the component elements are described in the following paragraphs. The major elements of the DMS are a DF-224 Computer (DF-224), a Data Management Unit (DMU), four Data Interface Units (DIU) (three in the SSM and one in the OTA), three Engineering/Science Tape Recorders (ESTR), and two Oven-Controlled Crystal Oscillators (OCXO).

All DMS hardware is located in the SSM equipment section (Figure 3-22) with the exception of DIU No 1, which is located in the OTA equipment section. All units incorporate some degree of redundancy or cross-strapping to provide a high degree of reliability and flexibility. Operational constraints or restrictions due to timing, power, thermal, or procedural considerations are contained in SMO-1020, Mission Operations Constraints and Restrictions, and in SDM-1001.

The types of commands and data signals to be handled by the DMS are listed as: (1) High Level Discrete (HLD) commands output to users also known as discrete power pulse commands, (2) Low Level Discrete (LLD), for the DIU only, commands output to users, (3) Serial Digital commands (messages) output to users, (4) Serial Digital data (messages) received from users, (5) Analog data received from users, (6) Bi-level data received from users, (7) Science data received from the Scientific Instruments Control and Data Handling (SI C&DH) module, (8) Continuous clock signal output to users, (9) Time synchronization pulse output to the SI C&DH, (10) Data correlation pulses output to users (Freeze pulse, major frame synchronization pulse, and minor frame synchronization pulse), (11) Serial Digital messages to the SI C&DH.

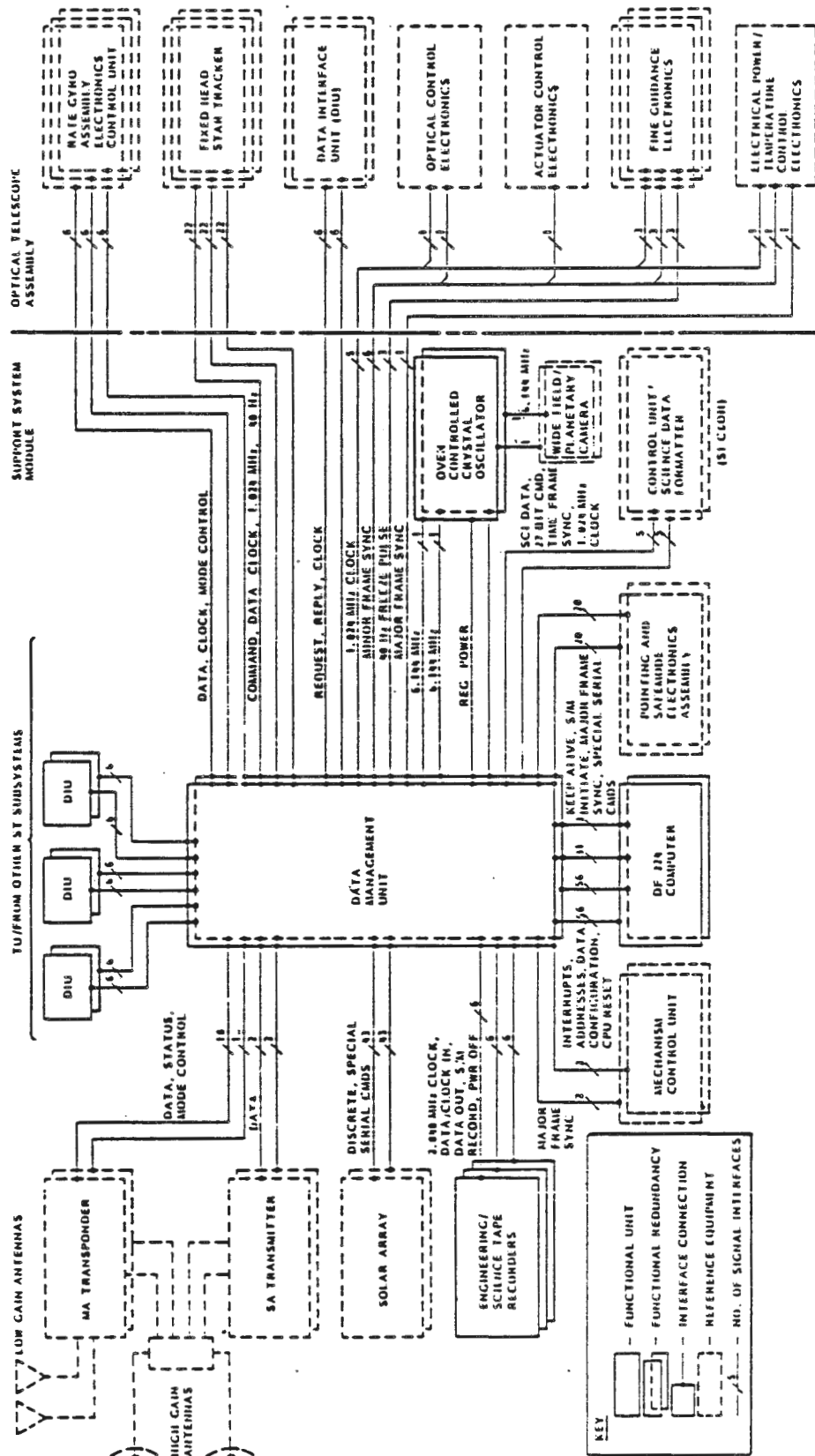

Figure 3-21 Data Management Functional Block Diagram

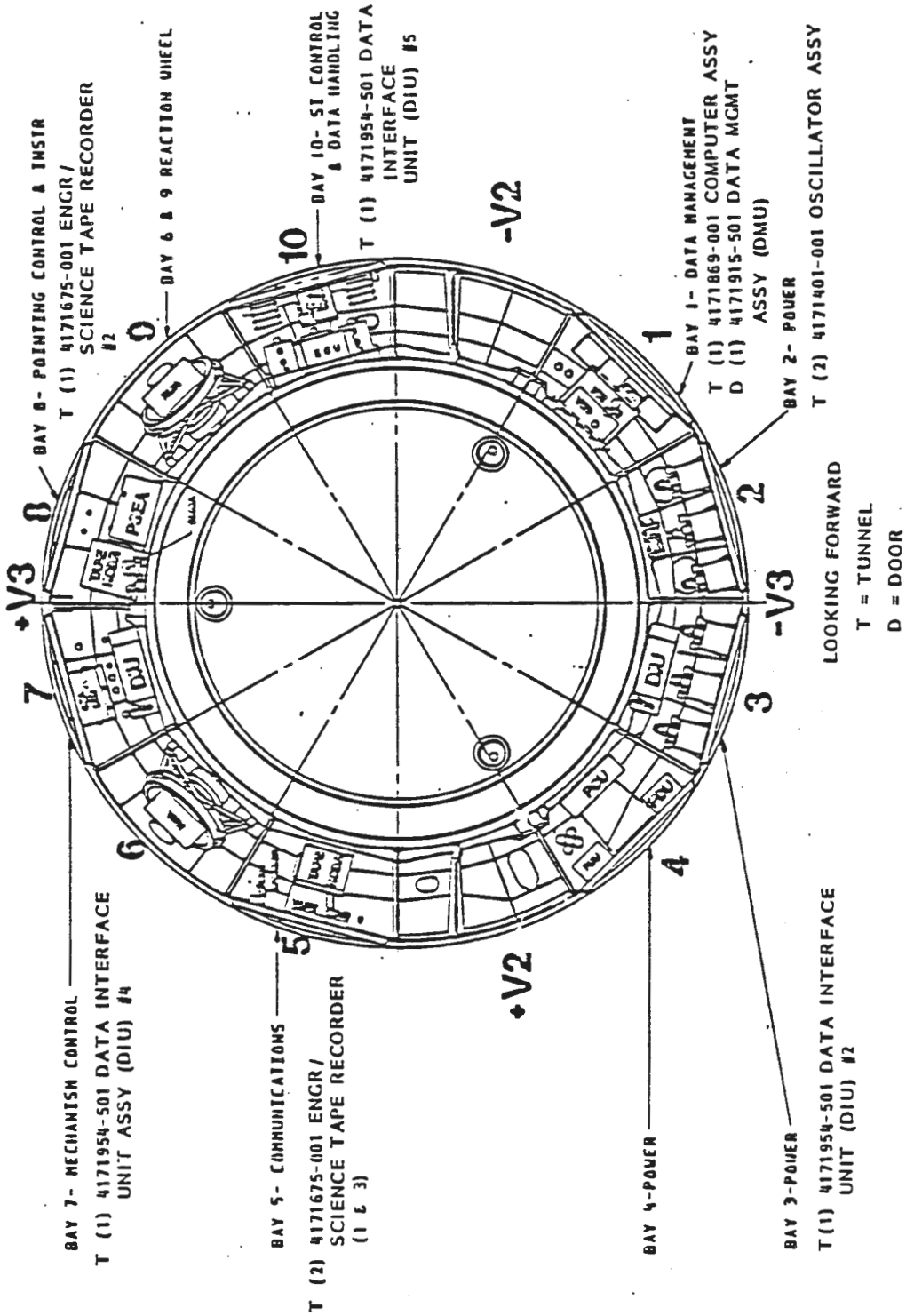

Figure 3-22 SSM Equipment Section DMS Component Locations

3.3.1 DF-224 Computer

The DF-224 Computer (Figure 3-23) is designed for long-life space applications, the DF-224 general purpose digital computer is a stored program, parallel single-address modular machine used for onboard engineering computations of the ST. Attitude control, execution of stored commands, telemetry format control, solar array orientation, power system monitoring, and antenna pointing control are the major functions of the computer.

The DF-224 is roughly 18x18x12 in. and weighs approximately 110 lb. It is located in Bay 1 of the SSM equipment section as indicated above.

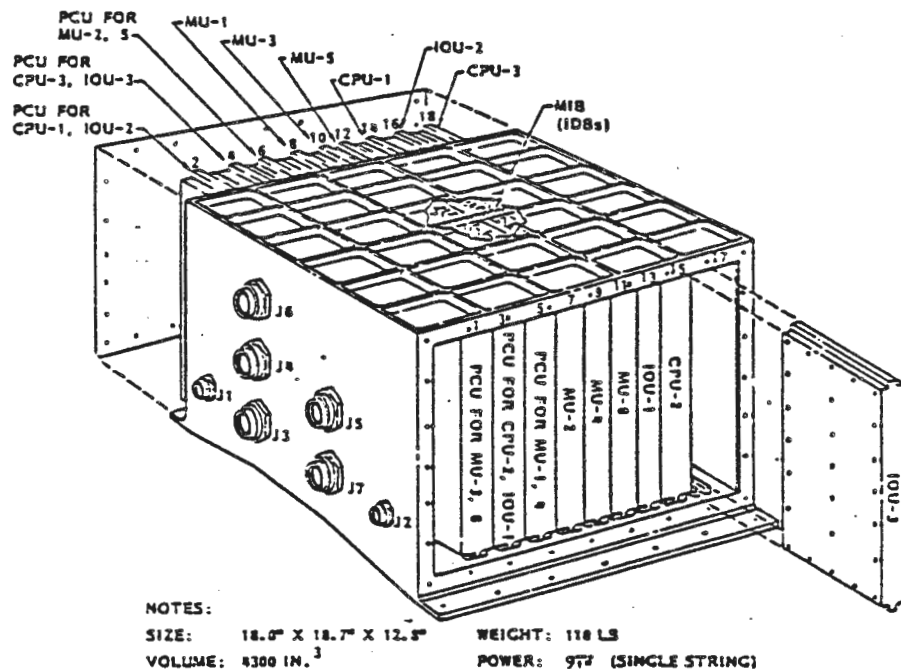

Figure 3-23 DF-224 Computer

The DF-224 is configured as a single-string computer with multiple backup units for reliability. Reconfiguration is by command from the ground only. The basic configuration consists of the following: (1) three identical Central Processing Units (CPUs), each having the capability to perform computations, format data, and transfer data; (2) six identical Memory Units (MUs), each providing 8K, 24-bit words of non-destructive readout storage of both data and instructions; (3) three identical Input/Output Units (IOU), each capable of providing an external parallel data interface to the DMU via two external data buses; (4) three Type-1 Power Converter Units (PCU-1) modules, each capable of providing power for two preassigned MUs (two PCU-1s per module); (5) three Type-Two Power Converter Unit (PCU-2s) modules, each capable of providing power for one preassigned CPU and one preassigned IOU (two PCU-2s per module).

3.3.1.1 Central Processing Unit (CPU)

Three identical CPUs, any one of which is capable of performing all the computations, data formatting, and data transfers, with the other two available as backup units.

The CPU is a programmable, single address, digital processor that executes sequences of instructions stored in memory. These instructions include arithmetic, load/store, logical, shift, branch, and special operations for a total repertoire of 153 instructions. Each of the three CPUs includes a control section, and arithmetic section, and a clocking system that uses a crystal oscillator to provide an 800-nsec internal system clock. There are three CPUs, but only one is used at a time.

3.3.1.2 Memory Unit (MU)

Six identical MUs, each of which is capable of providing 8K (8,192) words of non-destructive readout, non-volatile storage of both data and instructions for operational, executive, subroutine, and test programs.

3.3.1.3 Input/Output Unit (IOU)

Three identical IOUs, any one of which is capable of providing an external parallel data interface for the computer, with the other two available as backup units.

3.3.1.4 Internal Data Bus (IDB)

Three identical IDBs, each capable of providing communications between the CPU, MU, and, IOU as described above.

3.3.1.5 External Data Bus (EDB)

Two identical EDBs provide the capability for transfer of data between the IOUs and external equipment.

3.3.1.6 Power Control Unit (PCU)

The DF-224 has six dual PCUs, providing twelve independent power supplies, each dedicated to a logic unit or pair of MUs. Three PCU-1 units serve the six MUs and three PCU-2 units supply CPU-IOU combinations. Each of the twelve power supplies is individually switched on or off. In addition, each can be commanded, to select and activate the Internal Data Bus (IDB) ports.

3.3.2 Data Management Unit (DMU)

The DMU collects DMS functions into a single hardware package and provides interface between the DF-224 computer and all other subsystems and the ST modules. The block diagram (Figure 3-24) identifies many of the cards in the DMU and the external interfaces they serve.

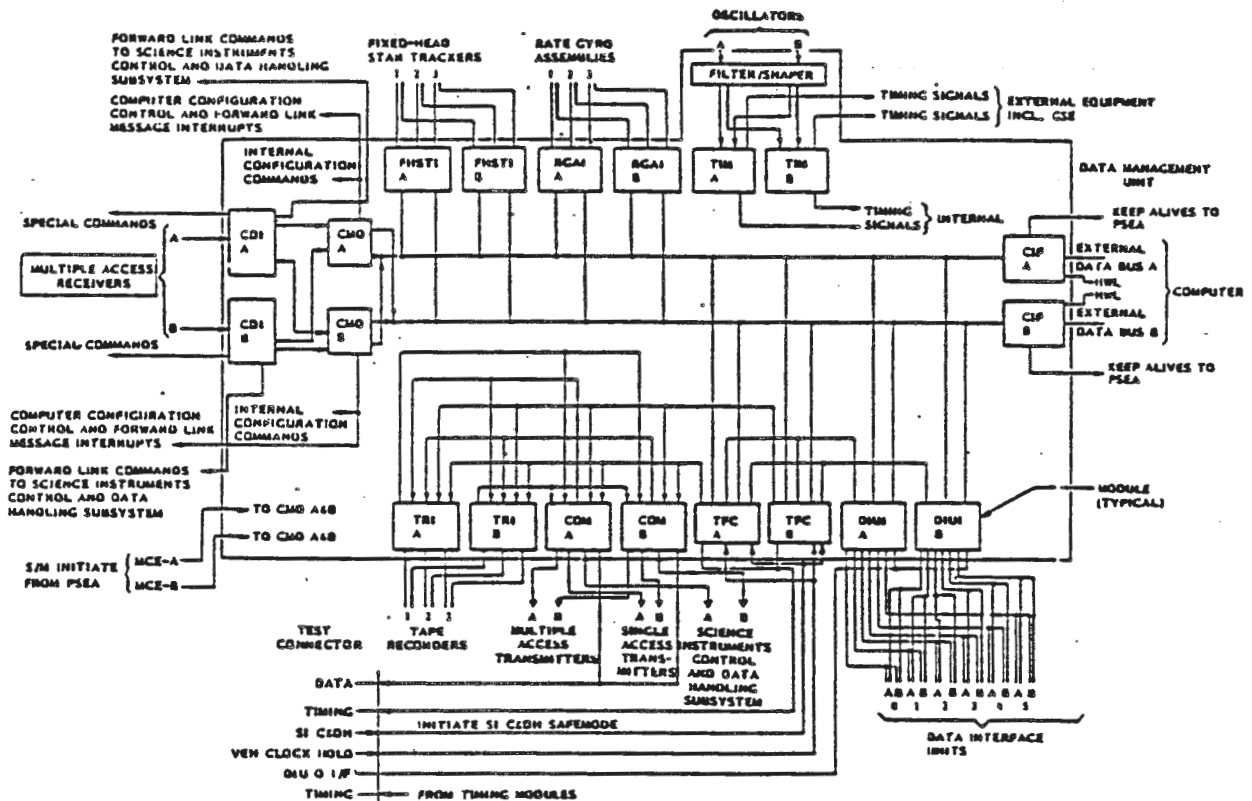

Figure 3-24 DMU Block Diagram

The principal functions are: (1) error-check forward link messages; (2) decode and distribute forward link messages, (3) format and encode return link telemetry; (4) provide dedicated interfaces for selected units on the ST; (5) provide interface circuits and logical operations as required to all units of the DMS; (6) provide regulated power to the Oven-Controlled Crystal Oscillators (OCXO); and (7) in conjunction with the oscillators, provide the central vehicle timing source.

The DMU accepts data from the FHSTs for comparison with a program in the computer. This program is part of the FHST update logic. Attitude commands are issued to the vehicle when required by the comparison.

The DMU accepts data from the Rate Gyro Assemblies (RGAs) and provides the angular rate data to the computer. The data are compared to a program in the computer, and commands are issued based on the comparison. There are three RGAs of two gyros each; four gyros are powered at one time each of which provides an input to the computer.

The DMU Assembly (Figure 3-25) consists of a single enclosure that houses the primary (A) and redundant (B) functional modules, dc/dc converters, and 38 connectors. The assembly is mounted on the door of the SSM-ES Bay 1, weighs approximately 83 lb, and measures 25.5 x 29.9 x 7.2 in. The functional modules, each composed of one or more 5x7-in. plug-in printed circuit boards, and each fully redundant, connect through a backplane to each other and by wire-wrap to external connectors. The two CDI dc/dc converters (power supply No. 2) are totally enclosed and also plug into the backplane. The two DMU dc/dc converters (power supply No. 1) that serve the rest of the DMU are also totally enclosed and are mounted on the inside end wall of the DMU box for good heat transfer.

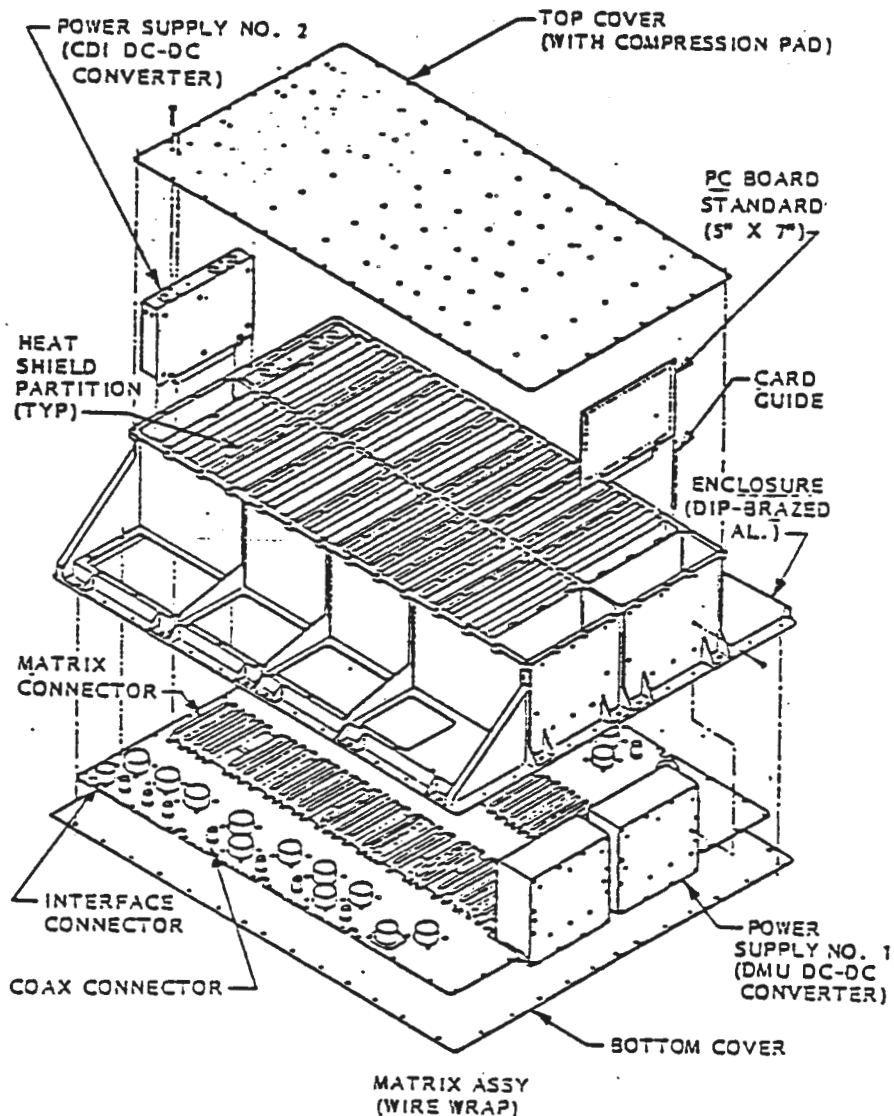

Figure 3-25 Data Management Unit Assembly

3.3.2.1 Timing

The DMU receives a 6.144 MHz sine wave from the master oscillator, counts down and generates various clock signals required by the ST. The timing function provides 40 Hz synchronization pulses to the DF-224 computer for synchronizing the software with spacecraft functions and a one kHz signal as a primary timing reference. The software generates a 32-bit ST vehicle time word with a least significant bit of 0.125 second, which can be set by Store Program Command (SPC) with a resolution of one second. The ST vehicle time word is transferred to the SI C&DH and is also output as four eight-bit words in the SSM telemetry data. The timing function also provides master timing pulses, minor and major frame synchronization pulses, and telemetry bit and word rate signals.

3.3.2.2 Engineering Data (ED) Handling

The ED are non-science data telemetered from the ST. The ED stream contains information (e.g., temperatures, voltages, status, etc.) about each of the ST subsystems, including the SIs and the SI C&DH. In the four KBPS formats, which are the normal formats, the ED are routed to the ground via a TDRSS Multiple Access (MA) link. ED are recorded on the Engineering/Science Tape Recorder (ESTR) when the link is not available. The ESTR is played back roughly once per day, but may be required to be played back as soon as possible for certain observations.

The ED will be used to assist in target acquisition, monitor SI status, verify that the schedule is being properly executed, and ensure that SIs are not only within health and safety limits but are also in a condition to generate meaningful science data.

3.3.2.3 Science Data (SD) Handling

The SD will be continually available in the POCC while the ST is in contact with TDRSS and the appropriate links are established. The SD may be transmitted at two basic rates, four KBPS and 1.024 Mbps. The low rate requires a TDRSS MA link, while the 1.024 Mbps rate requires an S-band Single Access (SSA) link. Although both of these links have to be scheduled, the MA link is expected to be routinely available. The use of the SSA link may be oversubscribed and will impact scheduling of ST operations. The on-board tape recorders can be used to record SD when Tracking and Data Relay Satellite (TDRSS) services are not available (e.g., zone of exclusion [ZOE] or no link available) or to back up important "one time only" SD. The tape recorder data are downlinked at 1.024 MBPS.

3.3.2.4 Telemetry Data Handling

The telemetry function provides timing and control signals to select telemetry formats and bit rates. This function contains the capability to provide three programmable (deployment, basic and diagnostic) and two fixed telemetry formats as described in the following paragraphs.

The deployment format is a 500 bps, software controlled, programmable format designed to be used during deployment operations when only the LGAs are available. The format structure provides 125 eight-bit words per minor frame and 20 minor frames per major frame.

The basic format is a four kbps, software controlled, programmable format designed to be used during normal day-to-day ST operations. The format structure provides 250 eight-bit words per minor frame and 120 minor frames per major frame.

The diagnostic format is a 32 kbps, software controlled, programmable format designed to provide data at a faster rate for OTA and SSM performance diagnosis or evaluation. The format structure provides 200 eight-bit words per minor frame and 1200 minor frames per major frame.

The four KBPS fixed format in DMS Read-Only Memory (ROM) is autonomously selected by the DMS in the event of an DF-224 computer failure. The format structure provides 125 eight-bit words per minor frame and 20 minor frames per major frame.

The 500 bps fixed format stored in DMS ROM is selected by ground command if for any reason the other formats are not available. The format is designed to provide the "bare bones" information necessary to evaluate essential SSM functions, and to identify critical ST modes and problem areas during severe contingency conditions. The format structure provides 125 eight-bit words per minor frame and 20 minor frames per major frame.

3.3.2.5 Forward Link Commands

Forward link command messages are received by the ST Communications Subsystem. These messages are forwarded to the Command Data Interface (CDI) module in the Data Management Unit (DMU) for all command validation and decoding of SI C&DH, PSEA, MA transponder, special SA serial messages, and special High Level Discrete (HLD) commands. All other messages are sent from the CDI module to the Command (CMD) module to be executed as Configuration Control (C/C) commands or to be input to the computer as Real Time Commands (RTC), Header, or Data words. In the DMU Computer bypass and Diagnostic modes, hardware RTC messages are output from the CMD module directly to the DIU Interface (DIUI) module for transmission to the DIU for execution, bypassing the computer.

3.3.3 Data Interface Unit (DIU)

The DIU is used to provide a common command and data interface between the DMS and other ST equipment. It receives instructions from the Data Management Unit (DMU) in the form of serial messages defining the operation to be performed. The DIU performs the operation requested and returns data and status information to the DMU. Each DIU contains two complete elements, either of which is capable of handling all the required functions. The basic design provides for issuing High Level Discrete (HLD) commands, Low Level Discrete (LLD) commands or Serial Digital Commands (SDC) messages to the users, and for accepting analog data, bi-level data and serial digital data messages from the users. Four flight DIUs are used on the ST. DIU-1, on the Optical Telescope Assembly (OTA) Equipment Section (Bay B), has full capability; DIU-2, DIU-4 and DIU-5, are mounted on the tunnel located in the SSM Equipment Section Bays (3, 7, and 10 respectively). The SSM DIUs are part of the DMS, and do not have the circuit board for LLD commands installed, since the SSM does not use these commands. The sockets are wired, however, for the low level drivers. Although the DMU is capable of interfacing with six redundant DIUs, port -3 is not used and port -0 is reserved for ground test use, such as interfacing with the pointing control subsystem simulator.

The physical description of the DIU is a box that measures approximately 15x16x7 in. and weighs 35 lb. DIU-1, used on the OTA, contains 19 printed circuit cards; the others contain 17 cards since the LLDs are not required. All units have two power supplies with two cards each. Connectors are located on both 7x16 sides.

3.3.3.1 Electrical/Thermal Characteristics

The "A" element of each DIU is provided with 28 Vdc power from both No 1 and No 2 Power Distribution Units (PDU) whenever the ST is powered up. Similarly, the "B" element of each DIU is provided with redundant power from PDU No 3 and No 4. Normal operation range is 24-32 Vdc, but the DIU is designed to survive power at 21-24 Vdc or 32-35 Vdc indefinitely. Each element has three states: off, standby (on), and active. Ground-originated HLDs are used to address individual DIU elements and apply or remove power to them. A power-on command brings the commanded element into the standby mode, and into fully operational condition within two seconds. Receipt of clock pulses from the DIU interface causes the DIU element to switch to the active mode; the absence of three consecutive clock pulses causes it to revert to the standby mode. An element consumes about 8.5 W in the standby mode; average power increase for the active mode is not significant. Normally only one element of a DIU is powered-on at a time. This is currently listed as a constraint to avoid box overheating, but recent thermal analyses using the measured power levels indicate safe temperatures with both elements turned on.

There are no provisions in the DIUs for heaters or other active thermal control devices. Passive thermal devices and techniques are used within the DIU box to conduct heat into the box walls and covers, from which it can be radiated. Maximum operating temperature for a worst case hot orbit environment is 52°C (91°F). For the worst case cold orbit environment, the calculated value is -37°C (-35°F).

3.3.3.2 Command and Data Handling Characteristics

A DIU element (A or B) is capable of handling 196 HLD power pulse commands and 20 SDC messages. In addition, the OTA DIU-1 can handle six LLD commands in element A and in Element B. All DIUs provide 215 analog data channels, 164 bi-level data channels and 16 serial digital data channels to the users from either the A element or the B element.

Direct ground control of DIUs is limited to power on and off commands to either DIU element, A or B. Each DIU element is supplied bus power by two separate fused lines from separate PDUs. Both primary and redundant power are available at the DIU interface connector when the PDU buses are energized. Within each DIU element are relays that will select either the primary or redundant line for power input. Normally, only one DIU element is powered at a time and either primary or redundant power feed selected. Having both primary and redundant power on effectively parallels fuses in two PDUs. Control of DIU power is by means of special Command Data Interface (CDI) HLDs. All DIU primary power discrettes are issued by CDI-A, and DIU redundant power commands are issued by CDI-B.

3.3.4 Engineering/Science Tape Recorders (ESTR)

Three identical tape recorders (Figure 3-26) are used in the DMS to store ED and SD. The tape recorder is housed in a hermetically sealed case approximately 12x9x7 in. and is pressurized to 18 psia (nominal). A pressure transducer provides pressure status on telemetry. Each ESTR weighs approximately 20.5 lb. The three recorders are installed in the SSM equipment section on the tunnels of Bays 5 (ESTR No. 1 and No. 3) and Bay 8 (ESTR No. 2).

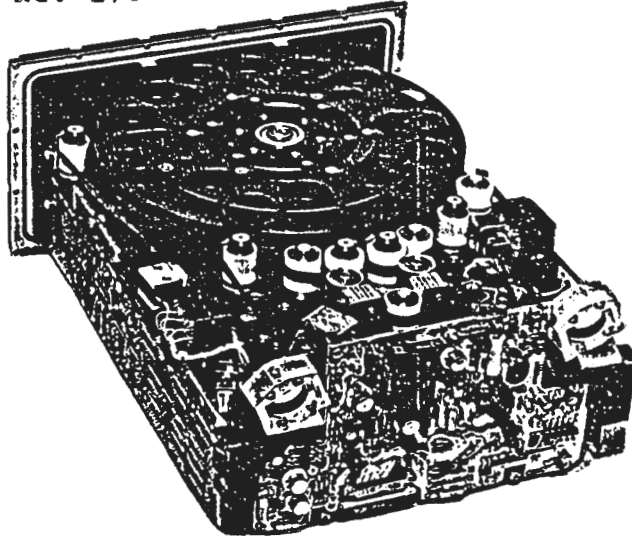

Figure 3-26 Internal Assembly of ESTR

One ESTR is assigned to record four Kbps, or 32 KBPS ED; a second unit is assigned to record four Kbps, 32 Kbps, or 1024 KBPS SD; and a third unit is assigned as the safemode recorder or used as a back-up. The safemode ESTR is used to record fixed format 4 Kbps ED in the event the ST enters safemode operation. The assignment of the three ESTRs is under ground control and will be rotated periodically to equalize wear on the tape recorders.

The unit records and plays back while running in either direction. It records in forward direction on track 1 and in reverse direction on track two and reproduces in a tape direction opposite to the record mode tape direction. Non-contact redundant End Of Tape (EOT) and Beginning Of Tape (BOT) sensors are provided to prevent tape breakage.

Data storage capacity is specified to be one gigabit, i.e., 1×10^9 bits. The actual capacity is 20 percent higher, providing overhead to absorb the tape used during multiple starts and stops. Twenty four record blocks of 1024 KBPS data, for example, will use up approximately 15 percent of the potential storage capacity during speed ramp ups and ramp downs.

Data quality is specified to be no more than one error in 1×10^6 bits of data, or a Bit Error Rate (BER) of 1×10^{-6} . Actual performance results in virtually error free data with a BER of less than 1×10^{-8} .

31 May 1985

The functional block diagram of the ESTR (Figure 3-27) shows the key derived design characteristics.

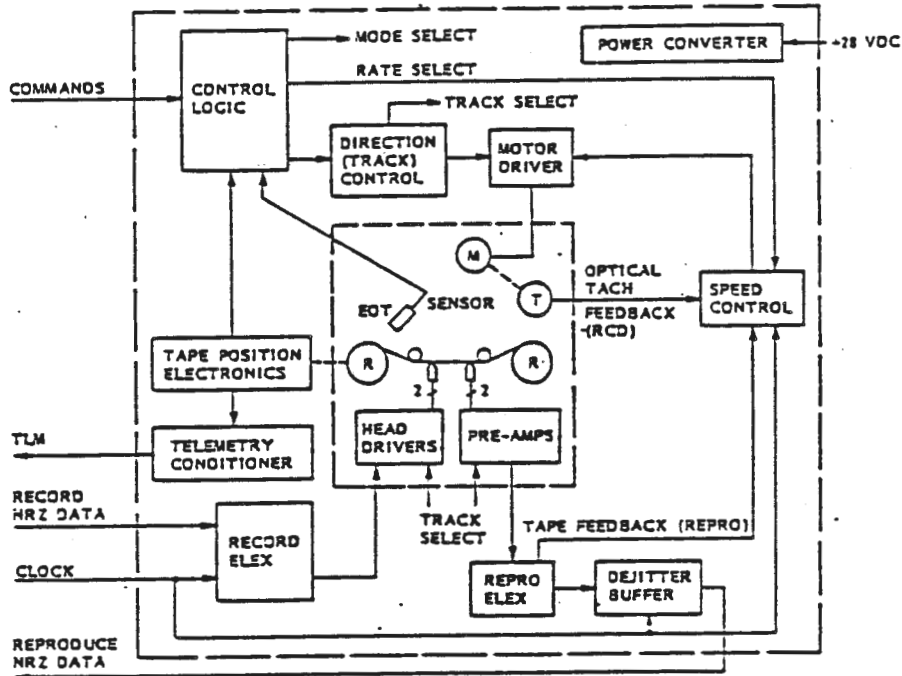

Figure 3-27 Functional Block Diagram of ESTR

The ESTR design features are:

- Tape Type ----- AMPEX 797, 1/4 in. wide, 1.0 mil thick
- Tape Length ----- 2068 ft of oxide, 41 ft of leader
- Tape Tracks ----- two, sequentially switched
- Data Packing Density - 25,000 bits/in.
- Recording Code ----- modified delay modulation
- Capstan Drive ----- ODETICS 3-Capstan drive, 3 redundant belts
- Motor ----- brushless dc motor with optical commutation
- Tachometer----- optical 2884 lines
- Reeling System ----- coaxial, counter-rotating
- Tape Tensioning ----- negator spring
- Heads ----- two record heads, two tracks each, alternating in erase and data recording functions. Two single track reproduce heads.
- Power ----- record, low rates (15 W)
 record, high rate (20 W)
 reproduce (27 W)
 fast wind/rewind (21 W)
- Record Time ----- low rates, 5.2 hours per track
- Record Reproduce Time- high rate, 9.75 min per track

3.3.5 Oven-Controlled Crystal Oscillator (OCXO)

The master oscillator consists of redundant OCXOs that provide a central time source for the ST. Only one of the two OCXOs may be powered on at a time. Each OCXO is capable of providing multiple, highly stable 6.144 MHz sine wave outputs. These stable frequencies are used within the DMU to generate ST vehicle time and the timing signals required for the DMS, OTA, and SI C&DH. The OCXO also provides an output directly to the Wide Field/Planetary Camera (WF/PC). The outputs are interfaced to the radial SI and DMU Filter Shaper Module using coaxial cables. The Filter Shaper Module outputs are cross-strapped to the Timing Interface Module A and B.

The oscillator (Figure 3-28) is enclosed in a cylindrical housing approximately four inches in diameter by nine inches long with two coaxial output connectors and one power/instrumentation connector mounted on one end. Both OCXOs are mounted in SSM equipment section Bay 2 on the tunnel wall. Each OCXO weighs 2.8 lb.

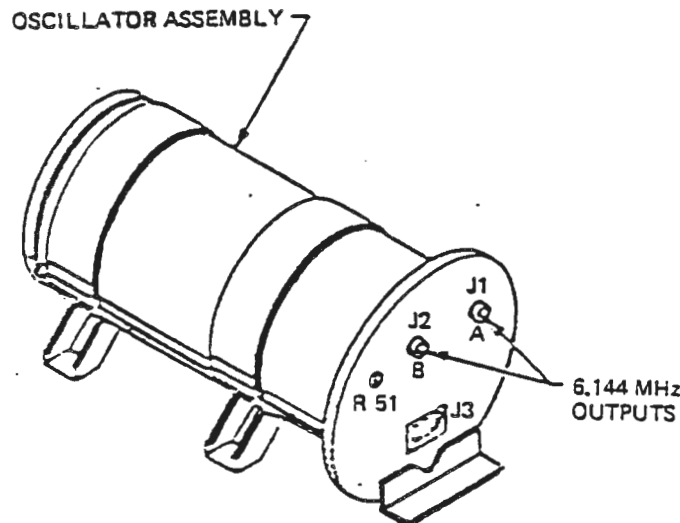

Figure 3-28 Oven-Controlled Crystal Oscillator

Only one OCXO is on at a time and although the OCXO will meet most of the specified parameters after a warmup of only 30 sec, it takes approximately 24 hours after power is applied to reach frequency accuracy and long term stability specifications.

An OCXO is selected by applying power to it and its associated bandpass filter. The OCXOs and filters derive their power from the DMU dc/dc converters. Whenever the DMU is powered on, one of the OCXOs is also on. The selection of the OCXO and filter/shaper (A or B) is controlled by special High Level Discrete (HLD) commands from the Command Data Interface (CDI) and modules. These HLD commands are wired internal to the DMU and are not brought to external connectors.

3.4 Pointing Control Subsystem (PCS)

The PCS provides the ST with the capability of pointing at designated targets with sufficient accuracy and for the necessary period of time to achieve mission objectives.

The primary PCS functions provide attitude reference, attitude control and stabilization, and vehicle maneuvering during ST orbit operations. These functions have been implemented by using PCS sensors, actuators and associated electronics. Functional control is provided by an on-board computer in the Data Management System (DMS), and other support from vehicle subsystems. A limited amount of ground support consistent with Tracking and Data Relay Satellite (TDRS) coverage will be required for data updates and commands. In the event of two major PCS failures, a backup system provides vehicle control and stabilization for ST retrieval by the Orbiter.

The secondary functions of the PCS provide: momentum desaturation, equipment calibration, health status determination, failure detection, isolation, and safemode attitude control.

The PCS operates in a digital mode uses software modules resident in the flight computer (DF-224) and hardware items physically located throughout the ST. A PCS Functional Block Diagram is shown in Figure 3-29.

3.4.1 PCS Hardware Description

The PCS equipment (Figure 3-30) can be divided into three categories: sensors, computer and actuators.

There are five different types of sensors that record ST attitude and rate measurements. These sensors are: Fine Guidance Sensor (FGS), Fixed Head Star Tracker (FHST), Coarse Sun Sensor (CSS), Magnetic Sensing System (MSS), and the Rate Gyro Assembly (RGA).

The DMS DF-224 computer calculates the control law, attitude updates, momentum management law and the command generators. To limit structural mode acceleration, the command generators shape the acceleration and incremental angle commands to the control systems in an accelerate, coast and decelerate pattern (DF-224 and Software; Ref. SE-23, Vol. IV.).

Finally, actuators turn the control signal into torques that move the vehicle. There are two kinds of actuators: the Reaction Wheel Assemblies (RWA), and the Magnetic Torquers (MTs).

Redundant hardware elements are provided to allow a timely resumption of science operations following a detected anomaly in system behavior.

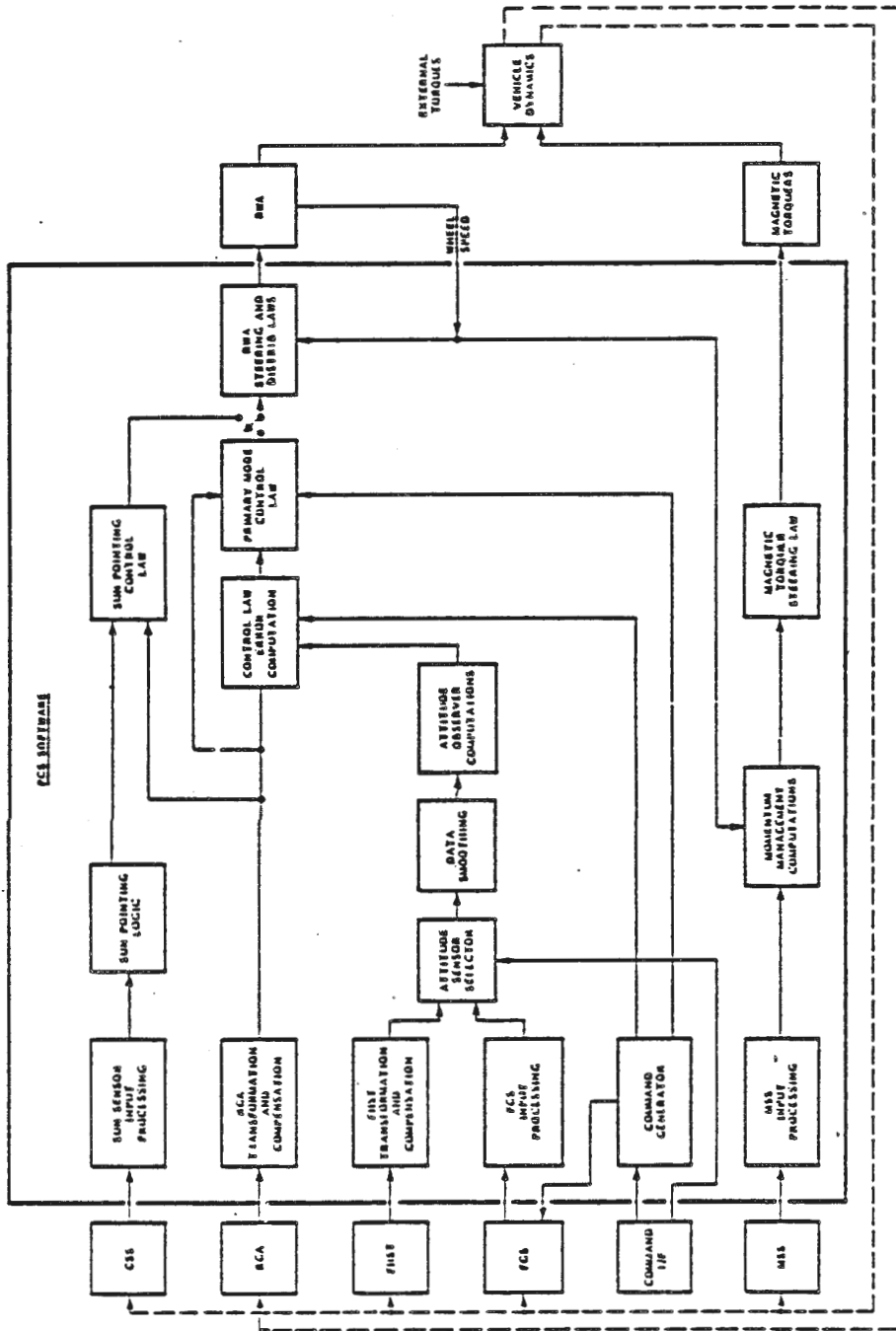

Figure 3-29 PCS Functional Diagram

Figure 3-29 PCS Functional Diagram

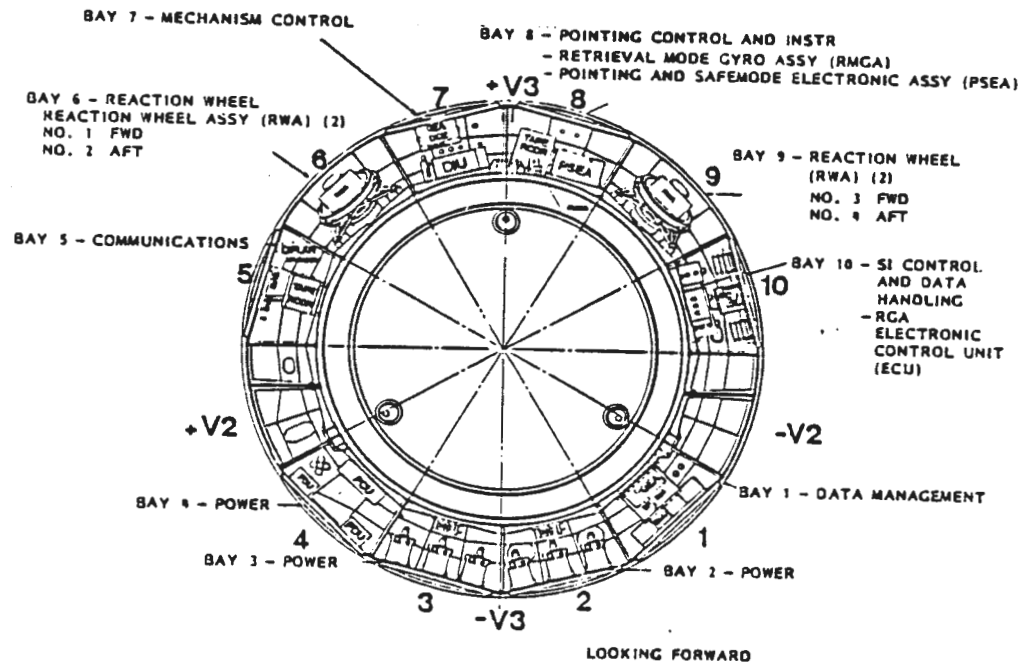
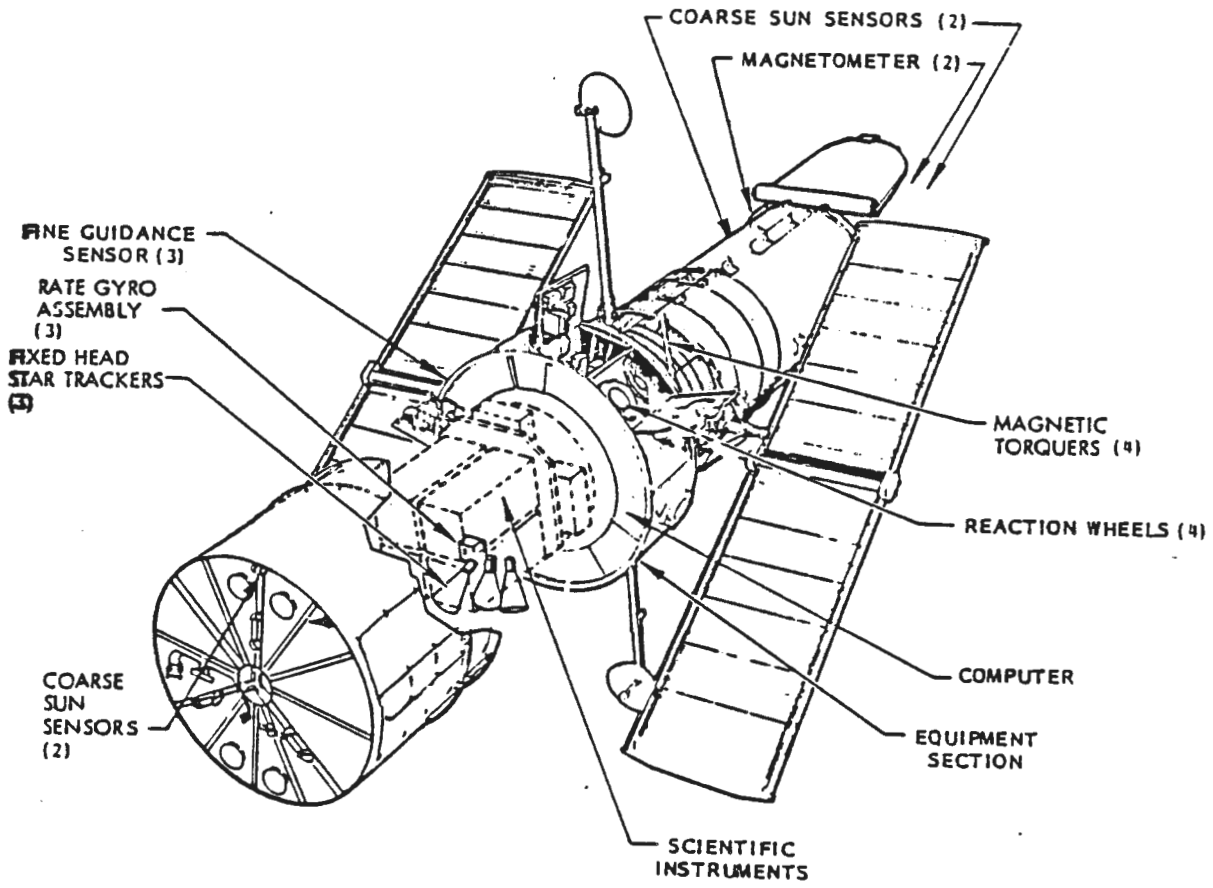

Figure 3-30 PCS Equipment Locations

3.4.1.1 Fine Guidance Sensor (FGS)

The three FGSs (Figure 3-31) are located radially around the outside edge of the OTA (Section 4.4). Each FGS is about five feet long and weighs 600 lb. The FGS generates attitude error signals during fine pointing about two orthogonal axes contained in a plane normal to the ST V1 axis. The PCS then controls torques on the ST to null the pointing error and thus stabilize the target image.

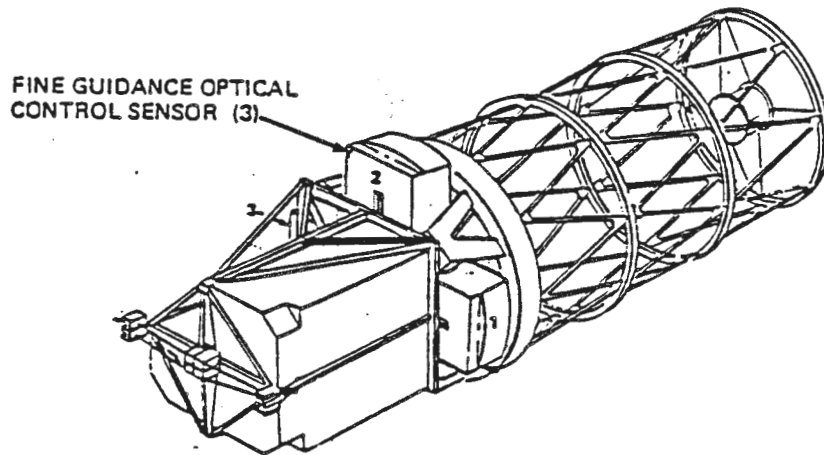

Figure 3-31 Location of Fine Guidance Sensors

The FGS is the most accurate and the most complicated of the sensors, which measures the angular position of a star. It uses the principle of interferometry to obtain an error signal that is accurate to fractions of an arcsec. Two of the three FGSs are used by the PCS to perform stellar pointing or low rate scanning. These sensors are used for attitude correction of the telescope Line Of Sight (LOS) with rate gyros used for rate and short term attitude information. Control about the LOS is provided by rate integrating gyros with information from the two FGSs being used to provide attitude corrections. The sensor that is not used for telescope pointing, which can be any one of the three FGS sensors, will be available for astrometric measurement.

An FGS sensor consists of a set of rotating mirrors such that any star within its field of view can be placed on an image dissector/interferometer combination. The encoder readings of the rotating mirror axes supply the objective position in the Field Of View (FOV); the output of each of the pair of interferometers supplies a fine error signal. The system determines accurate relative positions to ± 0.002 arcsec of all predesignated point sources within the FOV of the FGS astrometric sensor.

The FGS can be used in three astrometric modes: primary astrometric targets stationary with respect to the FOV; primary targets moving with respect to the FOV; and a scan to obtain the transfer function for each object in the FOV.

31 May 1985

3.4.1.2 Fixed Head Star Tracker (FHST)

The FHST is a sensitive, electro-optical detector which has the capability of locating and tracking a target star within its Field Of View (FOV). As part of the Pointing Control System sensor complement, the FHSTs perform the following functions:

0 Facilitate initial on-orbit PCS calibration following Space Transportation System (STS) deployment.

0 Update, together with the Fine Guidance Sensor and Rate Gyro Assembly by ST Operations Control Center (STOCC) command, the precision pointing reference of the PCS.

0 Obtain attitude information before and after a large scale maneuver to expedite the search process used by the FGS to locate a guide star.

Each FHST unit consists of the following major components and subsystems: (1) a 70 mm f/1.2 lens; (2) a one-in., magnetically deflected and focused image dissector tube; (3) power subsystem, (4) scan generators; (5) deflection circuits; (6) timing and control logic; (7) video processor; (8) input circuitry; and (9) output circuitry.

Three FHSTs make up the FHST system on the ST. For alignment stability, these units are mounted on the special Support Systems Module (SSM) Equipment Shelf (SSM-ES) platform near the Optical Telescope Assembly (OTA) focal plane, along with the Rate Sensing Units (RSU) of the Rate Gyro Assembly (RGA). Each FHST is individually aligned to its unique orientation with respect to the platform by an additional mounting fixture called a delta plate.

The optical axis of one FHST is oriented within 30 deg of the -V3 axis while the other two FHSTs are at a maximum angle from the first so that the FOV is not obstructed by the Solar Arrays. The location of the SSM-ES and FHSTs inside the ST aft shroud is shown in Figure 3-32.

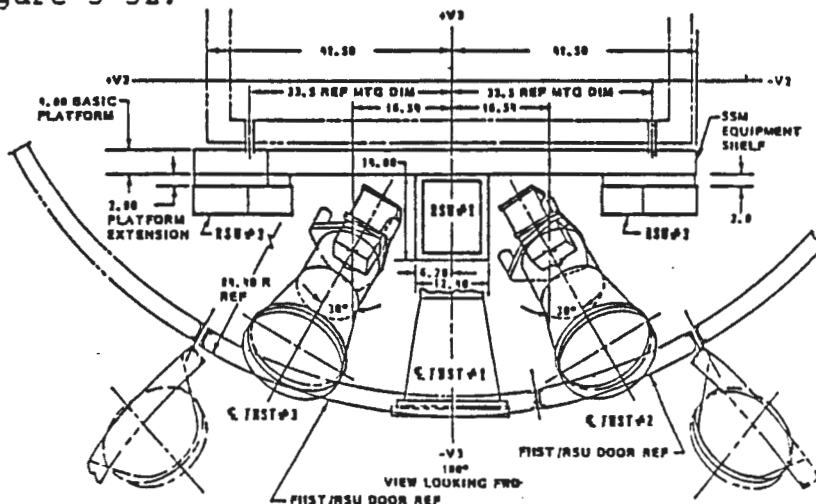

Figure 3-32 Fixed Head Star Tracker Locations on ST

3.4.1.3 Coarse Sun Sensor (CSS)

In addition to using stars for attitude information, the sun position will be measured by CSS. The CSSs are used in the initial attitude acquisition sequence upon deployment. Also, the CSSs are part of the backup control system.

Four CSSs (Figure 3-33) are installed on the SSM to provide greater than three Pi steradian coverage. Two are installed on the front end of the Light Shield Assembly and two on the Aft Shroud Assembly. Each CSS include three monitor sensors to provide analog outputs for determining the direction of the sun vector and two redundant control sensors to provide proportional error signals representing the error angle from the sun vector. The sensor outputs of the CSS are processed by the Pointing and Safemode Electronics Assembly (PSEA) and are used to: initiate Aperture Door (AD) closure whenever the sun reaches within 38 deg. of the +V1 axis; provide the sun reference during +V3 or -V1 sun point modes.

The physical characteristics of the CSS are an arrangement of the triple redundant monitor sensors and the double redundant control sensor pyramid. The CSS is approximately 2x2x1.5 in., weighs one-third lb and requires no input power.

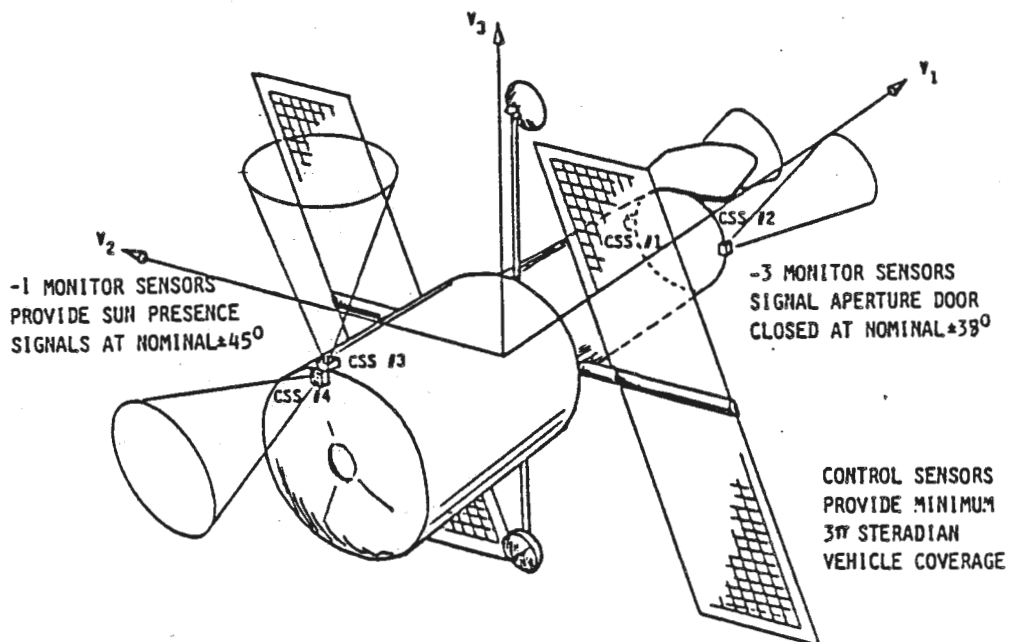

Figure 3-33 Coarse Sun Sensor Locations and Field of View

3.4.1.4 Magnetic Sensing System (MSS)

The MSS consist of two three-axis magnetometers (one redundant) to sense the earth's magnetic field with respect to the vehicle attitude. The magnetic field readings are compared with a model of the earth's magnetic field, stored onboard in the computer, to obtain an attitude reference. The magnetometers are used in both the control system, and the momentum management system. Outputs proportional to the field strength along each axis are used to calculate the required torquing currents for the magnetic torquer coils.

The two magnetometers (Figure 3-34) are located on the forward portion of the Optical Telescope Assembly (OTA) and are aligned with the vehicle axes. The MSS-2 sensor unit is aligned with the positive vehicle axes, the MSS-1 sensor unit is rotated 180 deg around Z axis (V3). Each MSS unit is positioned 54 deg from the +V3 axis in the V2-V3 plane. Since the magnetometer outputs are defined in terms of the positive X,Y and Z axes, the MSS-1 outputs correspond to -V1, -V2 and +V3.

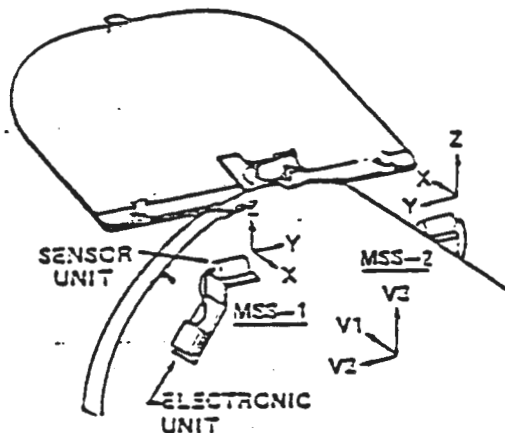

Figure 3-34 MSS Location and Alignment

The MSS output is used in the Primary PCS momentum desaturation control law and in analog safe mode control laws. The primary torque actuators consist of four Reaction Wheel Assemblies (RWA) which counteract vehicle disturbances and respond to maneuver commands through the DF-224 Flight Computer.

The MSS data are used in the DF-224 flight software by the Cross Product Momentum Management software and to correct for magnetic distortion in Fixed Head Star Tracker (FHST) data. The MSS is also a component of the backup attitude control system for the ST and, therefore, interfaces with the Pointing and Safemode Electronics Assembly (PSEA).

The Space Telescope Operations Control Center (STOCC) will use MSS data primarily for initial attitude determination during High Gain Antenna (HGA) acquisition of the Tracking and Data Relay Satellite System (TDRSS). The MSS data will also be used by the STOCC for attitude determination after a safemode condition.

3.4.1.5 Rate Gyro Assembly (RGA)

The RGA is a strapdown, reference gyro package. It senses vehicle motion using two modified, ultra-low noise Rate Integrating Gyros (RIG) to provide two-channel digital attitude and analog rate information. During normal vehicle operations, these rate and short term attitude updates are provided by the ST RGAs for fine pointing and spacecraft maneuvers. The RGA system is also used to produce inputs for Pointing Control System (PCS) operation during vehicle safemode.

A single RGA is composed of two separate subassemblies; the Rate Sensor Unit (RSU), which contains the RIGs, and the Electronics Control Unit (ECU). These two units are shown in Figure 3-35. The RSU weighs 24 lb, and the weight of the ECU is 17.5 lb. Both units are designated as Orbit Replaceable Units (ORU).

In order to reduce alignment errors among the three RSUs, and between the RGA and FHST, the RSUs are mounted on the SSM-ES along with the three FHST units. Sheet two of Appendix D shows the location of this equipment platform within the ST aft shroud. The three ECU boxes are mounted in Bay 10 of the SSM Equipment Section, as shown in Sheet four of Appendix D.

The input axis of each single-degree-of-freedom gyro is skewed relative to the ST axes. The RGAs sense vehicle motion and output incremental attitude data to the Data Management System (DMS). The data are received by the Data Management Unit (DMU) at 830 microsec intervals and accumulated into 25-msec samples to be used by the PCS for vehicle attitude control.

The rate gyros have a dual rate range. The high rate scale range is 1800 arcsec/sec (± 1800 deg/hr minimum), and the low rate scale is 20 arcsec/sec (± 20 deg/hr minimum). One of the gyro sensor units is redundant and kept in a dormant state unless needed.

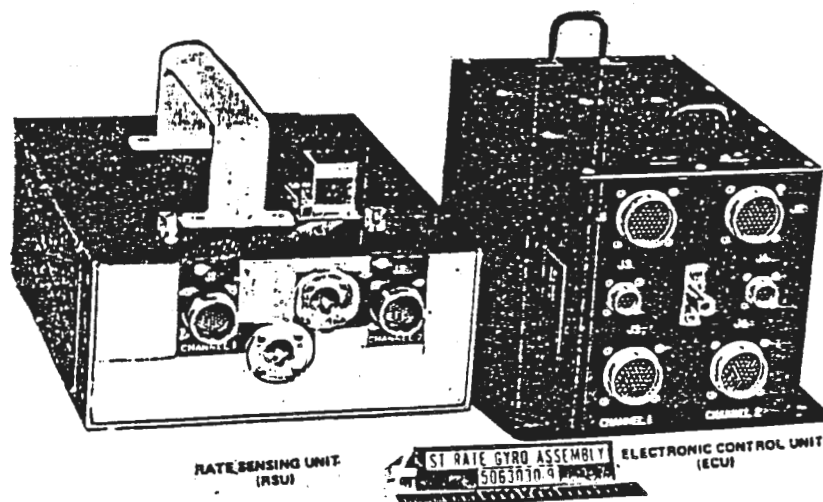

Figure 3-35 Rate Gyro Assembly

3.4.1.6 Computer

The computer, (see section 3.3.1) part of DMS Subsystem, calculates the control law, attitude updates, momentum management law, and the command generator. The command generator is a program which, in response to ground commands, calculates the reaction wheel input that maneuvers the vehicle from one orientation to another. The command generator is designed to accelerate, coast, and decelerate the vehicle smoothly enough that the flexing or vibration of the solar arrays and the telescope assembly itself is minimized. The purpose of the momentum management law is to prevent the reaction wheels from building up too much momentum in any one direction. This would eventually happen because the atmospheric drag and gravity gradient torques average a constant direction. The momentum management control system uses the Magnetic Torquers (MTs) to create an opposing torque to slow the wheels. Since the MTs are limited in the direction which they can create torque, a sophisticated computer program is required.

The computer itself has six 8 K, 24-bit words, plated wire memories, three central processing units and three input/output channels. The DMS, which transfers data between the computer and the hardware, has special data interfaces for the gyros, star trackers, and DIUs. The DIUs, which acquire all data with the exception of the gyro and star tracker digital data output, can send and receive 16-bit serial digital words.

In the event of a failure of one of the PCS components, the computer will go into a sun pointing safemode program. The +V3 axis is pointed to the sun to ensure power output from the SAs. The sun sensors, gyros, and magnetometers are used to determine attitude, and the RWAs and the MTs are used for actuation. Should a critical failure occur, such as two RWAs or the primary computer, control is transferred to a backup magnetic control system.

The backup magnetic control system is complete with its own rate gyros and microprocessor controller. The MTs are used for actuation. Since failure or malfunction of key elements of the pointing control system causes loss of attitude reference or vehicle tumbling, the backup system, which can capture the vehicle from unknown initial attitude and rates, is used to establish a specified orientation relative to the orbit plane. The critical parameter for the capture system is orientation of the vehicle so the SAs receive maximum illumination until primary control can be reestablished. Since the MTs generated against the earth's magnetic field are constrained to lie in a plane orthogonal to the geomagnetic field vector, only two-axis attitude reference and torque data can be obtained at any instant of time. Because the backup magnetic control system does not have stringent performance criteria, the backup rate gyros and the magnetometers are used together to determine the attitude reference. To develop three axis torque for local vertical control, the magnetic torque is augmented by gravity gradient torques. This magnetic control safemode is used only as a last resort since, in general, it is not recoverable.

3.4.1.7 Pointing and Safemode Electronics Assembly (PSEA)

The PSEA consists of three functional elements designated as the Magnetic Torquer Electronics (MTE), Safe Mode Computer (SMC), and Monitor and Control Electronics (MCE).

The MTE and four fixed bar magnets (Torqrods) comprise the Magnetic Torquing System (MTS). The MTE consists of eight identical magnetic torquer electronic channels. There are two redundant channels for each magnetic torqrod. Only one of each redundant channel will be energized at one time.

The SMCs consist of two identical independent electronics sections, designated as SMC A and SMC B, each of which has the capability to:

0 Sun point the vehicle in Sun Point Mode (SPM). The SPM is a software section of SMC A and SMC B used as a backup to the Data Management System (DMS) for the control function of pointing of a predetermined axis of the ST toward the sun. The SPM computes Reaction Wheel Assembly (RWA) torque commands and magnetic moment commands using vehicle rate provided by either the RGAs or Retrieval Mode Gyro Assembly (RMGA) and position information supplied by the the Coarse Sun Sensors (CSS). The SPM computes magnetic moment commands and provides these commands to the MTE. These moment commands based on the magnitude and direction of the momentum contained in the Reaction Wheel System and the earth magnetic field measured by the magnetometer.

0 Orient the vehicle in a Gravity Gradient Mode (GGM). The GGM is a software section of SMC A and SMC B which computes magnetic moment commands based on vehicle rates provided by either the RGAs or RMGA and earth's magnetic field data supplied by the magnetometer. It issues commands to the MTE portion of the PSEA for ST rate damping.

0 Implement the load control strategy contained in the memory.

0 Control the Solar Arrays during PSEA control.

The MCEs are independent electronics sections, designed as MCE A and MCE B, each of which has the capability to: command closing the Aperture Door when the optical axis of the vehicle is in proximity to the sun, process the Coarse Sun Sensor sun angle data for use by the DMS and SMC, monitor the health of the DMS and EPS as indicated by the presence of keep alive signals and store vehicle configuration data for use in hardware safe mode to execute the load control strategy.

3.4.1.8 Reaction Wheel Assembly (RWA)

Four RWAs are employed to provide momentum storage capability to maintain the ST in an accurate inertial hold attitude and to supply control torques for maneuvering.

The physical characteristics (Figure 3-36) of the RWA consists of the following major components: large rotating mass or flywheel, torquer of drive motor, tachometer or speed sensor, power supply, tach and motor control electronics. Total weight of this unit is approximately 103 lb. The rotor inertia is sized at 0.84 kg-m², adequate to compensate for the adverse effects of worst case environmental torques, wheel speed uncertainties, and the possibility of one failed wheel. The wheel has an output torque range of 0.004 to ± 0.7 N-m compatible with a speed range of zero to $\pm 3,000$ rpm, respectively.

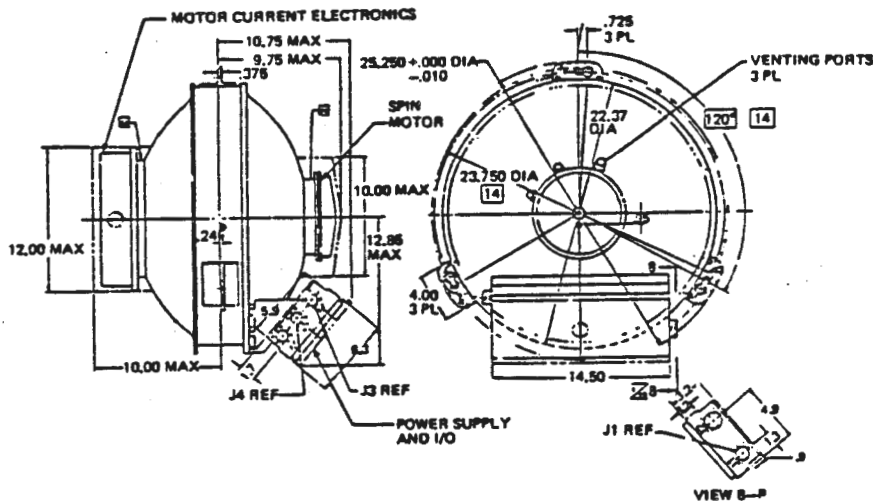

Figure 3-36 Reaction Wheel Assembly Physical Characteristics

Each RWA (Figure 3-37) spin axis is oriented at 45 deg to the V2-V3 axes and 20 deg above the V2-V3 plane to provide system redundancy. Thus, the pointing control system can operate using only four gyro channels and three reaction wheels.

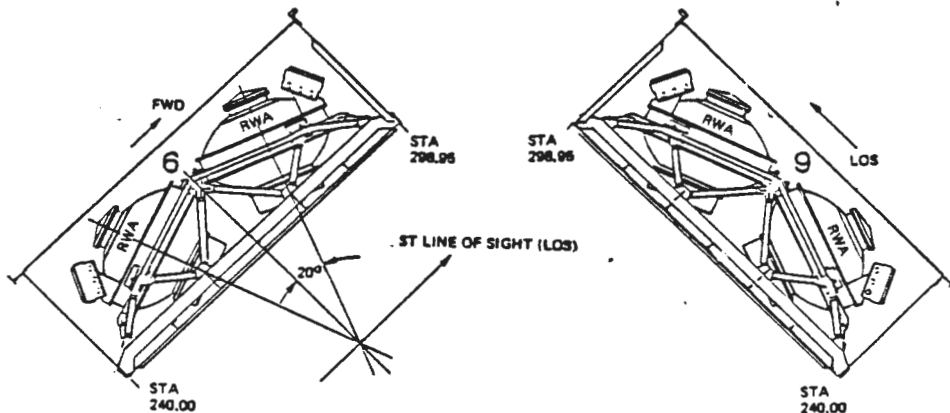

Figure 3-37 RWA Position Detailed View

3.4.1.9 Magnetic Torquing System (MTS)

The MTS consists of four Torquers and Magnetic Torquer Electronics to supply control torques for RWA momentum desaturation. The magnetic torquers (MTs) are limited in that the torque created must be in a direction perpendicular to the earth's magnetic field lines. The MTS also provides backup control during initial stabilization of the ST after deployment from the Orbiter, and during restabilization of the ST for retrieval by the Orbiter in the event an RWA, RGA, or computer failure occurs.

The magnetic torquer coils (four required) are wound on a cylindrical iron core measuring approximately 100 in. long by 3 in. in diameter and can produce a magnetic moment of 2,800 A-m squared at rated current. The units have a 100 percent duty cycle, require 16 W at peak power, and weigh not more than 100 lb each. They are mounted external to the Forward Shell (FS) (Figure 3-38) with the axes oriented at 45 deg to the V2-V3 axes and 35.26 deg above the V2-V3 plane.

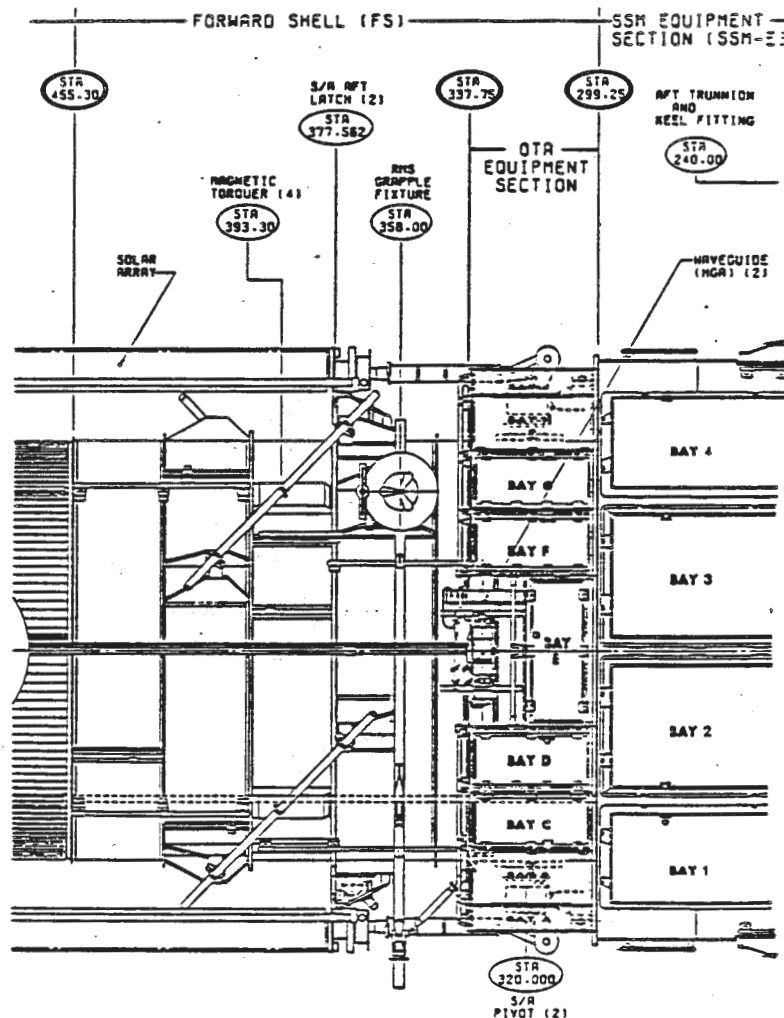

Figure 3-38 Magnetic Torquer Location

3.4.1.10 Retrieval Mode Gyro Assembly (RMGA)

The RMGA is an element of a backup system for attitude stabilization in the gravity gradient and hardware sun point modes. In the event that less than three RGAs are available, the RMGA will be used to provide vehicle rate signals for rate damping. It will sense rate about three orthogonal axes and provide analog output signals proportional to the rate.

The RMGA is made up of three single-degree-of-freedom gyroscopes design with long-life precision bearings. Performance requirements for this unit are much less precise than for the RGA. Though it substitutes in place of the RGAs, the ST performance is limited to emergency survival when the RMGA is in use.

The RMGA power interface is from PDU four, which supplies fused switched power to the RMGA from all three ST power buses. PDU "on"/"off" control of the RMGA via commands from STOCC or from the PSEA. The RMGAs will be powered only during orbital testing, or when two RGAs fail the reasonableness checks performed by the PSEA. The RMGA draws 20 W when operating.

Heaters in Equipment Section Bay 8 are provided on the door for the ICU and on the tape recorder mounting bracket. No special thermal provisions are made for the RMGA, as the environment in the bay provided by the other equipment and their heaters maintains the environment well within the RMGA temperature limits.

There is no direct ground command interface with the RMGA per se. The power is applied by a command to the PDU. The Spin Motor Rotation Detector (SMRD) is the only monitor routed directly from the RMGA to DIU four, and this bi-level reads "1" approximately 30 sec after turn-"on" when the gyro exceeds 90 percent of synchronous speed. The three torquer commands, and set rate bias for the RMGA can be issued to the PSEA, and the settings can be monitored via PSEA outputs.

3.4.2 PCS Functions

The PCS has three functions, autonomous maneuvering, star acquisition, and fine pointing. When the ST receives a command to slew, the RWA torque signals are computed by the command generator and fed forward directly to the RWAs. During the maneuver, the FGS is disabled, and the vehicle is under gyro control only. After a long maneuver, the FHSTs can be used for an attitude update.

Once the vehicle is in the desired orientation, the FGSs must acquire their guide stars. This is done in three steps, search, coarse track, and fine lock. When the search mode is initiated, the instantaneous Field of View (FOV) is moved outward in an Archimedes spiral by the Star Selector Servos (SSS). The spiral scans out to 30 arcsec within 150 sec with sufficient FOV overlap to assure star detection while experiencing up to a maximum of 0.05 deg/hr of uncompensated vehicle drift. The FGS is programmed to look only for a star of a predesignated brightness. When the FGS is in this search mode, the outputs of the four Photomultiplier Tubes (PMT) are summed to create the detection signal.

After star detection in spiral scan, the FGS will command the five arcsec square FOV to encircle the star position at the rate of once per second with a radius of 2.6 arcsec. The star's position is then determined by averaging the sums and differences of the photomultiplier counts in sectors of the coarse track circle and commanding the center of the circle to balance the detected signals. The purpose of this mode is to more accurately determine the location of the guide star in preparation for transition to the final fine lock mode. At this point, the four PMTs are put into the interferometric mode. Now a signal from the FGS can detect the star only when the star is in the ± 0.04 arcsec wide interferometric characteristics contained in the instantaneous FOV. The ± 0.04 by ± 0.04 arcsec square interferometric Interface (I/F) center square is ultimately where the guide star must lie for fine pointing.

After 16 cycles of coarse track, the star selector servos positions the I/F center at a point 0.6 arcsec from the FGS's estimate of the guide star's position, equally offset along the X and Y axes. Then the I/F center is stepped down the diagonal direction toward the estimated position with 0.009 arcsec steps at 40 Hz. When a sufficient signal is detected in the I/F center along one axis, the search is stopped and the I/F locks on in that axis. The other axis resumes stepping until it detects the star and locks on.

Once fine lock has been achieved by the primary FGS, an attitude update is calculated, and the secondary FGS's SSS are adjusted accordingly. Then, the second FGS goes through the same sequence to acquire its guide star. When both guide stars are acquired in fine lock, the vehicle attitude is adjusted to place the target star in the aperture entrance of the specified science instrument.

When in fine lock mode, the movements of the vehicle are so slight that the equations of motion reduce to a linear decoupled form, and the control of the three axes (roll, pitch, and yaw) can be considered independently. The block diagram on the PCS for one axis only is shown in Figure 3-29.

Two basic components are involved in the PCS software program: the observer, which calculates the attitude updates, and the controller, which calculates wheel commands based on the attitude error. The observer accepts both the attitude signal obtained by integrating the rate gyro output, and the FGS output. These signals are averaged over one second intervals, and then processed to provide a gyro drift correction. The attitude reference signal is created by integrating the rate gyro outputs at 40 Hz, with one-sec gyro drift corrections from the observer. This attitude signal is then passed into the controller, where it is amplified and also integrated. A rate signal is taken directly from the gyros and passed through a filter. These three signals are then added to create the wheel command signal.

The various observer and controller gains were chosen to satisfy the stability margin and response time criteria. Stability problems caused by the solar array and telescope assembly bending modes necessitated the filter in the rate feedback path. The closed loop bandwidth of the PCS is 1 to 2 Hz.

3.4.3 Operational Modes

The operational modes are: deployment, system calibration, ST slew, guide star and target star acquisitions, coarse and fine pointing, scanning maneuvers, solar system object tracking, and contingency attitude control. ST attitude reference is maintained by means of quaternion algorithm processing within the DF-224 computer.

3.4.3.1 Deployment Mode

During deployment and in some contingency modes, attitude data are obtained from the magnetometers that sense the earth's magnetic field and Coarse Sun Sensors (CSS) that sense the attitude of the sun. The ST is deployed with an inertial orientation. The ST PCS will damp initial tip-off rates and retain an inertial orientation.

3.4.3.2 Systems Calibration

During slews, initial system calibrations, and coarse pointing attitude data are obtained from the Rate Gyro Assembly (RGA) and the Fixed Head Star Tracker (FHST). During final system calibrations and all other modes, attitude data are obtained from the RGA and the Fine Guidance Sensors (FGS). Critical pointing requirements are: slew rate 0.25 deg/sec max, time to complete 90 deg Slew 18 min, coarse pointing accuracy ± 3.5 arcsec, plus 1 arcsec/deg of maneuver, and fine pointing accuracy 0.007 arcsec RMS.

3.4.3.3 Attitude Determination

After the deployment procedure is complete, initial attitude determination is performed. To first establish the approximate orientation of the vehicle, the Coarse Sun Sensor (CSS) and Magnetic Sensing System (MSS) are used as attitude sensors. The ST is rotated to orient with the +V3 axis toward the sun.

The magnetometer measures the three orthogonal components of the earth's magnetic field in vehicle coordinates. In combination with a STOCC model of the earth's field and with orbit ephemeris knowledge, the magnetometer output will determine the V3 attitude.

The total attitude determination procedure includes three basic steps: (1) sun point with the -V1 axis aligned to the sun; (2) key Star Acquisition when the vehicle is oriented so that a selected star will be within the field of view of FHST number one; and (3) Second Star Acquisition requiring a roll about the eigenvector of star number one to the orientation that places a second reference star in the field of view of another FHST. "Key" stars are isolated from similar (ΔmV less than 1.2) neighboring stars by a minimum of 4.8 deg.

3.4.3.4 Attitude Update

Attitude updates to correct for PCS attitude errors due to uncompensated RGA drift are obtained from either averaged FHST or FGS attitude. The FHST data are averaged for 20 sec and FGS data are averaged for one second. PCS attitude updates are made at the end of each averaging period. The attitude update are made using an attitude observer process.

3.4.3.5 Maneuvers

Space Telescope maneuvers are accomplished by mechanization of an on-board software Command Generator.

The Command Generator accepts time tagged ST eigenaxis commands which were previously uplinked and stored in the flight computer memory. The Command Generator is mechanized for a (one-cosine) jerk pulse. The jerk pulse width is chosen for an acceptable excitation of the solar array pointing error contribution following the maneuver. The maneuver target-to-target commands are stored in the flight computer memory to implement consecutive maneuvers, allowing the desired time in the fine pointing mode between maneuvers. The eigenaxis commands are with the quaternion implementation of the attitude reference system. The large angle maneuver will be either velocity limited, acceleration limited, or jerk limited dependent on the maneuver angle. The Command Generator operates on a one second major cycle which generates coefficients used in a basic cycle (40 Hz) quaternion interpolation. The interpolation outputs a relative command quaternion which commands rate to the ST control law every 25 msec. A feed-ahead acceleration command is utilized as a reaction wheel torque command. The jerk pulse magnitude and ST velocity during the maneuver is sized to accomplish a 90 deg maneuver in 14 min.

Reaction wheel maximum speed attained during the maneuver is determined from initial momentum conditions and maximum ST angular velocity. The baseline system is designed for a 0.153 deg/sec velocity during maneuvers.

Since the baseline large angle maneuver minimum time is 240 sec when using the 60-sec jerk pulse, a small angle maneuver technique, spline function, that is more time conservative is used where applicable.

3.4.3.6 FGS Guide Star Acquisition

The ST attitude at the end of the maneuver is the nominal command orientation in inertial space. The attitude command reference stored in the PCS command generator is generally the best orientation data available until FGS guide star acquisition is completed.

The FGS acquisition Field of View (FOV) is 180 sec in diameter. The selected guide star is within the FGS total FOV, an annular sector that covers at least 60 square arc min.

The FGS autonomously coarse acquires each guide star while the ST is controlled in the Gyro Hold mode. A coarse acquisition signal from the FGS allows attitude hold reference. Following FGS fine acquisition, the PCS starts to control the star selector and uses the fine error signal as a rate and attitude reference for the Primary PCS in the fine pointing mode. In the fine pointing mode, the star selector commands are generated using the software command generator.

3.4.3.7 Fine Pointing Mode

Following the acquisition of guide stars in two FGSs, the fine pointing mode can begin. This primary ST mode is designed to accomplish a pointing stability of 0.007 arcsec (one sigma). The PCS ensures total ST stability following detected failures and system reconfiguration and when left with the minimum primary PCS complement of components (i.e., three gyro channels, three reaction wheel assemblies, three magnetic torquer bars, etc.).

The fine pointing mode uses the FGS for derived rate for the V2 and V3 axis control. For V1 rate control, the RGA output is updated by FGS position. The PCS fine pointing accuracy is highly dependent upon the FGS equivalent noise error. The FGS contribution to the pointing stability therefore vary, dependent on the noise output of the FGS.

3.5 Electrical Power Subsystem (EPS)

The EPS (Figure 3-39) provides electrical power generation, storage, and distribution to the ST equipment. Electrical power is supplied to the Solar Array (SA) Electronics Control Assembly (ECA), SSM, Optical Telescope Assembly (OTA), Scientific Instruments Control and Data Handling (SI C&DH) module, and five Scientific Instruments (SIs). Power generated by a deployable retractable SA simultaneously supplies the ST load requirements and energy storage for the batteries in the sunlight period of each orbit revolution. During the eclipse period, energy stored in the batteries is distributed to the ST equipment. The EPS contains provisions for autonomous power management, monitoring of EPS parameters for power management at a ground station, battery charge control and command control. The EPS also provides an electrical interface to the Orbiter via the Space Support Equipment (SSE).

Major hardware elements of the EPS are two SA wings, one Deployment Control Electronics (DCE), two SA Drive Electronics (SADE), six secondary batteries, six Charge Current Controllers (CCC), one Power Control Unit (PCU), and four Power Distribution Units (PDUs).

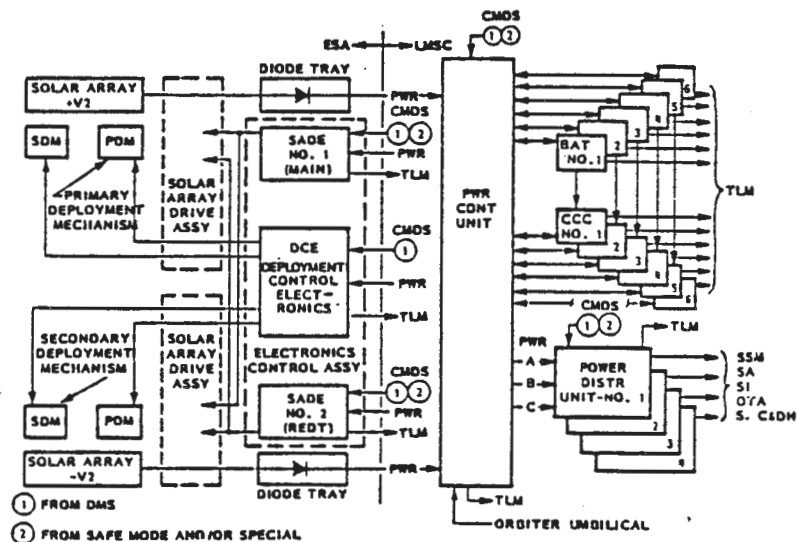

Figure 3-39 Electrical Power Subsystem Block Diagram.

Circuit protection (fusing) is provided in the distribution circuits to ensure safe and reliable operation of the EPS. These devices are sized to protect ST wire harnesses and EPS equipment from short circuits occurring in the using equipment. Separate power lines from redundant circuits are routed through separate redundant connectors to supply power to this equipment. Switching devices are used to control power to the various components of equipment and are capable of switching currents up to the fuse rating of the protective devices, inrush currents, and voltage transients.

The SSM Equipment Section (Figure 3-40) houses the EPS equipment.

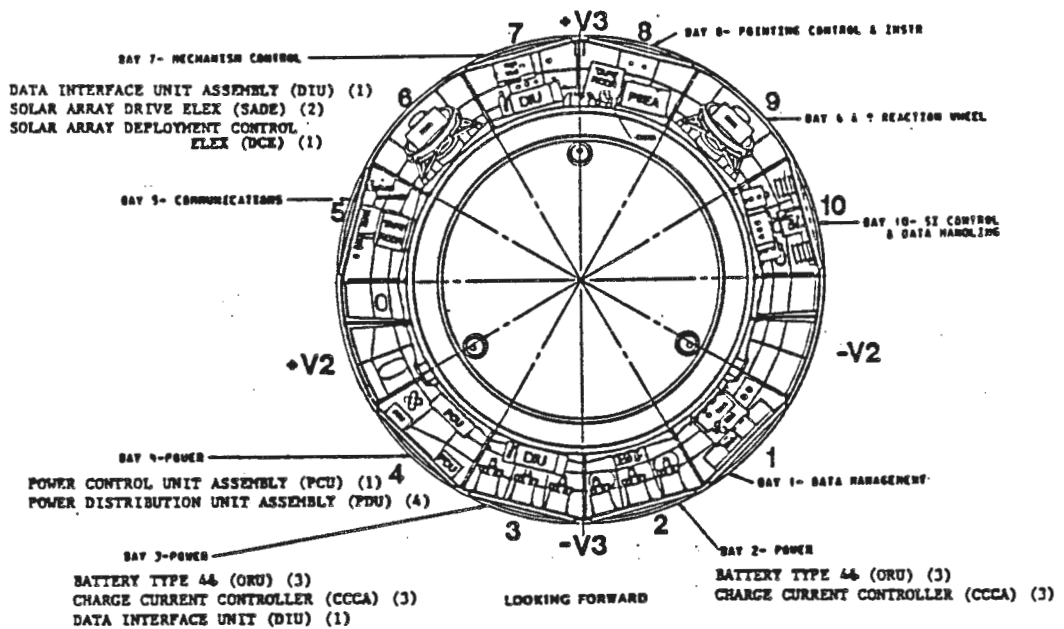

Figure 3-40 EPS Equipment Location in ST Equipment Section

The ST power return buses are referenced to ST structures at one point within the SSM via the Single Point Ground (SPG). The SPG is capable of being connected to the Orbiter through the SSM umbilical and is designed to carry the maximum expected fault current. All SSM, OTA, SA, ECA, SI, and SI C&DH dc power is isolated from all component structures. Electrical umbilical connections are provided on the ST to mate with the SSE when the ST is installed in the Shuttle bay for ground check out, ascent, retrieval, or during in-orbit planned maintenance.

The EPS contains provisions for remote power management, monitoring, and control overrides to permit flexibility during orbit operations. The EPS also contain multi-level voltage steps for charging the batteries with the capability of raising or lowering the charge cutoff voltage.

The battery chargers completely recharge the batteries in each orbit during normal observation attitudes, although failure to achieve complete recharge is acceptable in one orbit in each 24-hr period. After off-normal roll maneuvers, the battery chargers completely replenish battery energy within five orbits. The average depth of discharge over a 24-hr period will not exceed 20 percent with one battery out. ST electrical power during periods when the ST is berthed or stowed in the Orbiter is drawn from the Orbiter through the SSM.

3.5.1 Solar Array (SA)

The SA arrangement (Figure 3-41) consists of two fully interchangeable wings, each comprising two flexible solar cell blankets, supporting structure, instrumentation, cushion blanket, storage drum and the necessary deployment retraction and orientation mechanisms. An Electronic Control Assembly (ECA) is mounted in Bay 7 of the SSM and consists of the Deployment Control Electronics (DCE) and the Solar Array Drive Electronics (SADE) for both wings. A diode box is mounted near each wing external to the equipment section.

Electrical power is generated by the solar cell panels and is passed to the SSM PCU for conditioning and distribution. Power for all SA motors and instruments is controlled by the ECA, which also accepts commands from the SSM and conditions data from the SA system for transmission to the SSM Digital Interface Units (DIU).

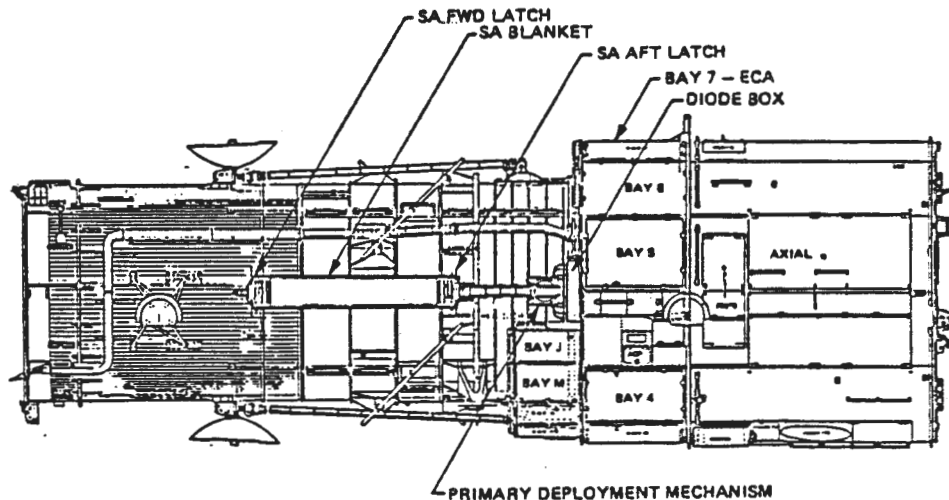

Figure 3-41 Solar Array Arrangement

Each wing has a diode box which provides the isolation diodes for power from each of the Solar Panel Assemblies (SPA) and interconnect interface between the electronics and the deployment and positioning mechanisms. The diode box is an Orbital Replacement Unit (ORU) and also provides the means for disconnecting the cables from the SA should jettison of the array be required. Connector modules that permit removal of two or four connectors at a time by using a ratchet wrench on the drive screw provided are the means of disconnect. Each connector module is equipped with a tether loop to restrain the wire harness after disconnect. Each diode box measures 4.75 x 6 x 33.9 in. and is located external to the ST on the forward face of the SSM equipment section near the Solar Array Drive (SAD)/SSM interface.

The electronics for the SA known as the Electronics Control Assembly (ECA) is located in Bay 7 of the SSM equipment section. The ECA consists of the DCE and the SADE.

3.5.1.1 Solar Array Drive Electronics (SADE)

The SADE consists of two units, either capable of sending wing position commands to the array wing.

3.5.1.2 Deployment Control Electronics (DCE)

The DCE is a single internally redundant unit, which controls the primary and secondary deployment and retraction functions of the SA wings and monitors the characteristics related to the deployment mechanisms and the SA. During normal operations the DCE will be powered off except for periodic telemetry checks, which require turning the unit on.

The DCE is a fully standby redundant subsystem, in which the two separated parts utilize no interconnections except at inputs and outputs in order to ensure that a failure in one part of the DCE does not propagate to the redundant part.

The DCE contains a dc/dc converter for the supply of all internal logic and signal conditioning. However, due to power level and heat dissipation requirements, the motors are supplied directly from the main buses. The converter control logic, the instrumentation switches, and the motor voltage/current monitors are also supplied directly from the main buses. The discrete commands for the DCE activate relays in the DCE.

The signal conditioning and control (Figure 3-42) acquires and disseminates all data and control signals related to the control and monitoring of primary and secondary deployment. It also routes and conditions information via telemetry from the following SA instrumentation for both wings: 10 accelerometers, four strain gauges or potentiometers, 16 microswitches, 10 thermistors and six platinum resistance sensors.

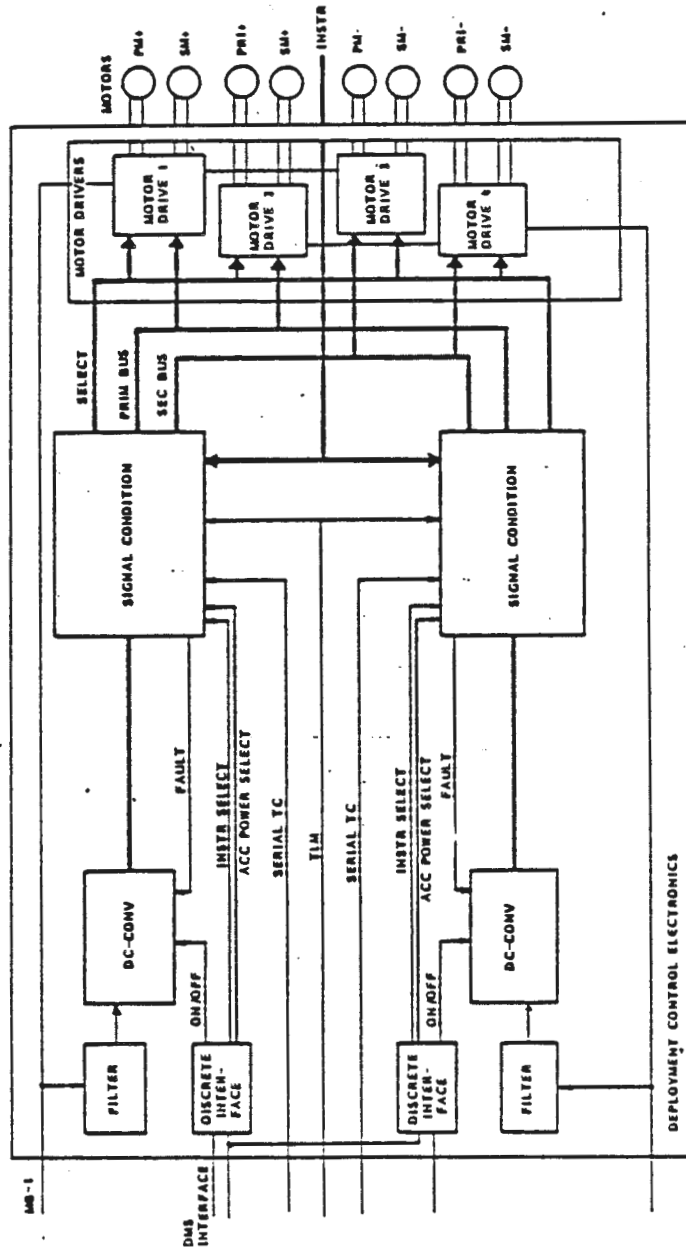

Figure 3-42 DCE Block and Interconnect Diagram.

The motor control circuit enables the desired motor configuration and terminates deployment when confirmation (deployed/restowed) is obtained from the pertinent microswitches. The performance of the SA wings is identified by the status flags "wing active," +wing/-wing, respectively. An internal failure detection logic is provided that automatically and instantaneously switches off the DCE and raises the failure detection flag when an excessive current is drained by the motors, the accelerometers, or the converters. Furthermore, the primary motor voltages are monitored and a low voltage will cause immediate switch-off. Figure 3-43 is a detailed block diagram of the signal conditioner.

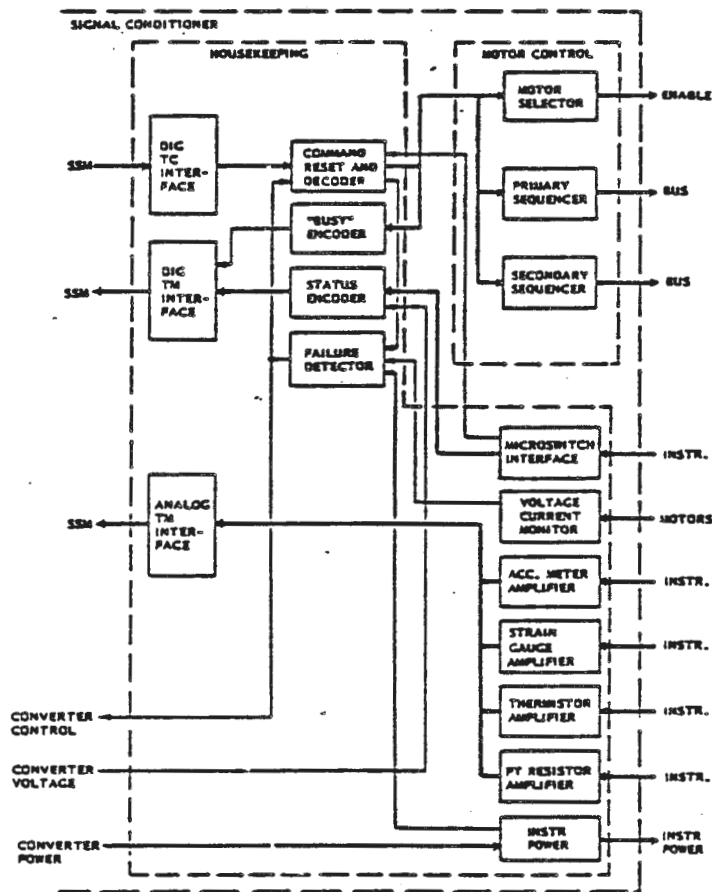

Figure 3-43 ST SA-DCE Signal Conditioner Block Diagram

There are eight motor drivers, one for each motor on the SA mechanisms. The SA wings are operated through a Primary Deployment Mechanism (PDM) and Secondary Deployment Mechanism (SDM). On each wing, a main and a redundant motor are provided for each mechanism. One motor is capable of operating the mechanism to full extend. The power supply for these drivers is obtained from the two independent main buses. Cross-strapping between the essential blocks has been provided so that signal conditioner one or two will supply the control signals for the motor drivers and condition the SA instrumentation signals.

3.5.2 Batteries

Six type 44 batteries manufactured by Eagle Picher provide ST vehicle power during eclipse and during other periods when vehicle loads exceed solar array capability. Each battery, weighing a maximum of 135 lb, consists of 23 series-connected Nickel-Cadmium (Ni-Cd) cells, as illustrated in Figure 3-44, with stainless steel cases. Each cell is sealed and fitted with a pressure relief valve set to open at 200 ± 25 psi and reset at above 100 psi. Under normal operation internal cell pressure will not exceed 30 psi.

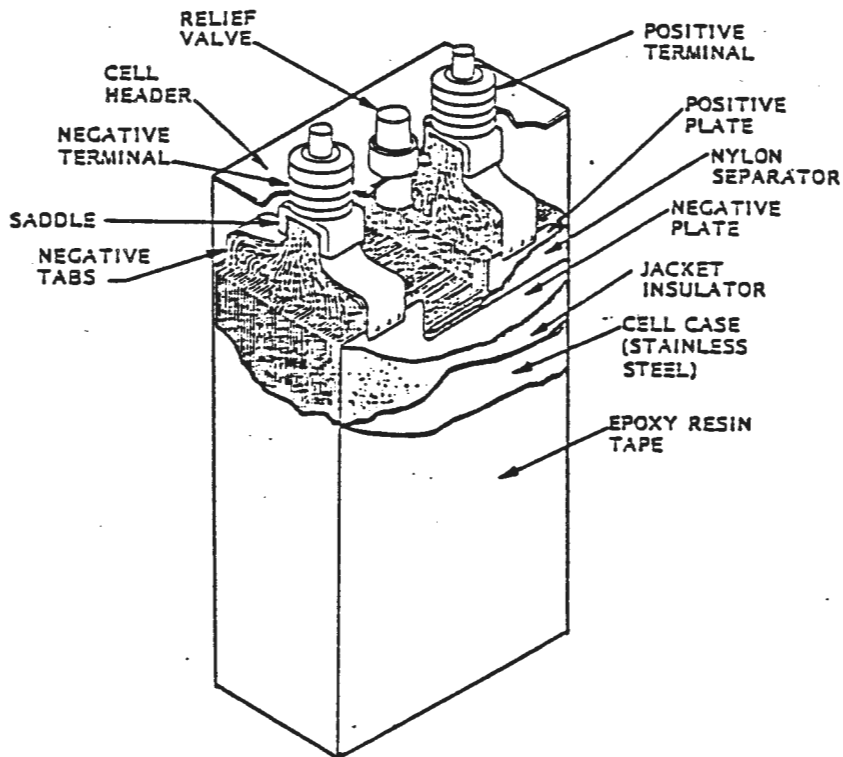

Figure 3-44 Nickel-Cadmium RSN 55-3 Cell (23 per Type 44 Battery)

The cells are housed in a cast aluminum battery case which contains 23 cavities partitioned much like an egg-crate. Each cell is bonded to the five walls of its individual cavity with an epoxy adhesive. The battery case is also sealed with a magnesium cover and a handle which allows the astronauts to remove batteries for resupply. A pressure relief valve set to open at 15 ± 5 psi and to close above five psi is also installed on the battery case.

Monitoring of battery current and maintenance of battery temperature are provided by a bi-directional current sensor and two (redundant) temperature control systems. The current sensor provides a 0-5 Vdc output signal proportional to the magnitude of charge/discharge currents. The battery heaters are rated at 40 W and either will sustain the battery at an optimum operating temperature in the ST environment.

The primary and redundant heaters are turned "on" at nominal temperatures of 32°F and 21°F, respectively. The corresponding "OFF" temperatures are 35°F and 25°F.

The six batteries are installed in two groups of three each on the ST doors of the SSM Bays 2 and 3. Six astronaut-compatible hook-type fasteners are used to attach each unit to the bay doors.

The battery is designed to deliver a minimum capacity of 60 A-hr to a cutoff voltage of 26.1 Vdc at a discharge rate of 10 A. The battery will accept charging currents of up to 17 A safely, provided a charging voltage limit of 34.5 Vdc is not exceeded.

Cycling of the battery over an extended time period results in a progressive degradation of discharge voltage. Factors that significantly increase the rate of voltage decay are higher battery temperatures (above 60°F) and depths of discharge (over 20 percent).

The degradation is ascribed to changes in the structure of plate active materials and redistribution of electrolyte. This degradation is noted as a reduced voltage from the discharged battery after the ST exits an eclipse. This degradation gradually increases over an extended period. Unless a random failure has occurred, the degradation is reversible. Near original battery performance is restored by "reconditioning," a technique consisting of one or more discharges at very low rates (0.5 A) to an average voltage of 1 Vdc per cell.

The batteries are recharged by a SA through Charge Current Controllers (CCC). Each battery is energy supported by three switchable panels from the SA. The three panels for each battery are geometrically selected within the SA to ensure equal energy distribution. The EPS is a three main bus system. These buses are normally tied together but will automatically separate if a large overload or structure current is detected.

Battery charging is controlled by the CCCs. There are six CCCs, each dedicated to a specific battery. Each CCC monitors the terminal voltage and cell temperature for a specific battery and utilizes these parameters to control the K1 and K2 charge control relays located within the PCU. Trip points for these relays can be changed by ground command (four selectable settings for each K1 and K2 relay) to compensate for changes in system behavior due to battery aging.

3.5.2.1 Battery Protection and Reconditioning Circuit (BPRC)

Battery reconditioning is controlled by the BPRC which consists of a dc-to-dc converter with a low voltage, full wave rectifier output connected in parallel with each cell. The BPRC provides protection for the battery by ensuring that no cell reverses during reconditioning. During normal operation the BPRC circuit is isolated from the cells by reverse biasing diodes. In this mode its standby power is three watts. When the battery discharges, cells at the lower state of charge allow Schottky diodes to become forward biased and the BPRC for that cell begins to support the battery output voltage. This increases the input current to the BPRC. A maximum input current of approximately 1.75 A is reached during the reconditioning cycle when all cells have been discharged to and held at approximately 0.5 V per cell. The discharge period required for a complete battery reconditioning is three days. If a cell fails to maintain a charge the BPRC supports that cell's voltage and provides the path for the battery current so that the battery will continue to provide its share of the vehicle load.

The BPRC is composed of an input electronics drive circuit mounted on a two-ounce copper printed circuit board. The output circuit is mounted adjacent to the input circuit.

Four sections are identified on the input circuit. Section 1 is the input filter and regulator, Section 2 is the main logic control, Section 3 the enable and Section 4 the hexfet drive circuit. A block diagram of the BPRC is shown in Figure 3-45.

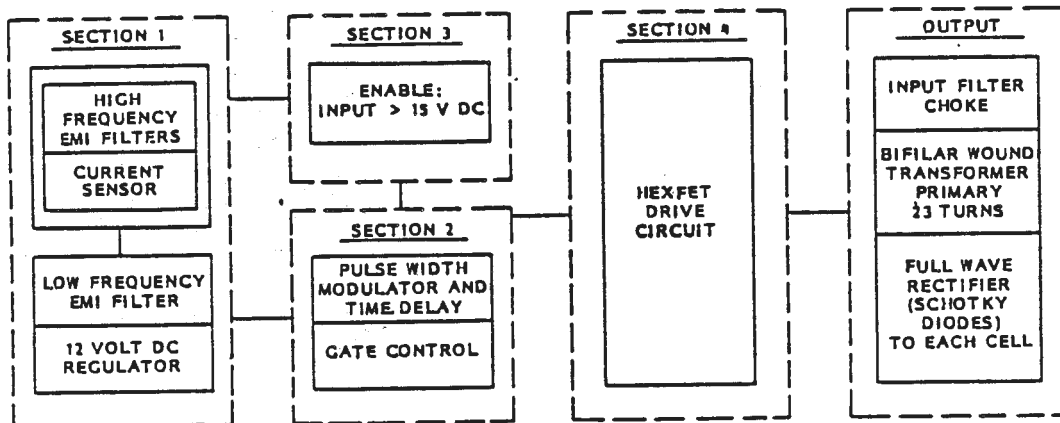

Figure 3-45 BPRC Block Diagram

Section 1 consists of an EMI filter and a series pass regulator that supplies +12 V to the rest of the logic circuit.

Section 2 consists of a 40 kHz clock, a one microsecond time delay circuit, a frequency divider (2), a pulse width modulator, and a control gate.

Section 3 consists of an enable circuit which holds the control gate off until the input voltage is more than 15 V.

Section 4 consists of a buffer and hexfet drive circuit connected to the primary of the transformer.

The output circuit consists of an input filter choke, and an output transformer with a bifilar wound full wave rectified low voltage output winding to each cell which is fused separately.

3.5.2.2 Input Circuit Assembly

The input circuit is mounted on a two-ounce, two sided printed circuit board measuring 0.063 x 6.25 x 4.434 in. The circuit board is supported by seven mounting holes on two sides and will be conformally coated prior to installation. The diode plate is 0.094-in. thick aluminum alloy 12 by 6.67 in. The plate is attached to the battery case extension with number 6 size hardware for good thermal conduction to the battery case. The plate contains 46 Schottky diodes attached in series with 16 AWG wires. Each pair of diodes has one terminal for the 14 AWG battery connection and one terminal for the upstream pair of diode wires. These are attached to the diode pair using smaller gage wires as fuses. The diode plate is conformally coated after assembly.

3.5.2.3 Battery Case Extension

The battery case extension is an aluminum frame match-drilled to individual battery cases and covers. It contains ribs and flanges for mounting the circuit assembly and diode plate assembly. Mounting holes will be provided for one current sensor and two line filters adjacent to the circuit card assembly. Provisions are made for EMI protection, hermeticity, and handling fixtures now used on the battery case/cover assembly.

3.5.3 Charge Current Controllers (CCC)

The purpose of the CCC (Figure 3-46) is to provide multilevel, voltage-temperature control of battery charging through two independent channels. The CCC measures 8.13 x 7.62 x 4.5 in. and weighs approximately 4.9 lb. The power consumption is less than four watts with a operating voltage of 24 to 32 Vdc and a survival voltage of 21 to 24 and 32 to 35 Vdc.

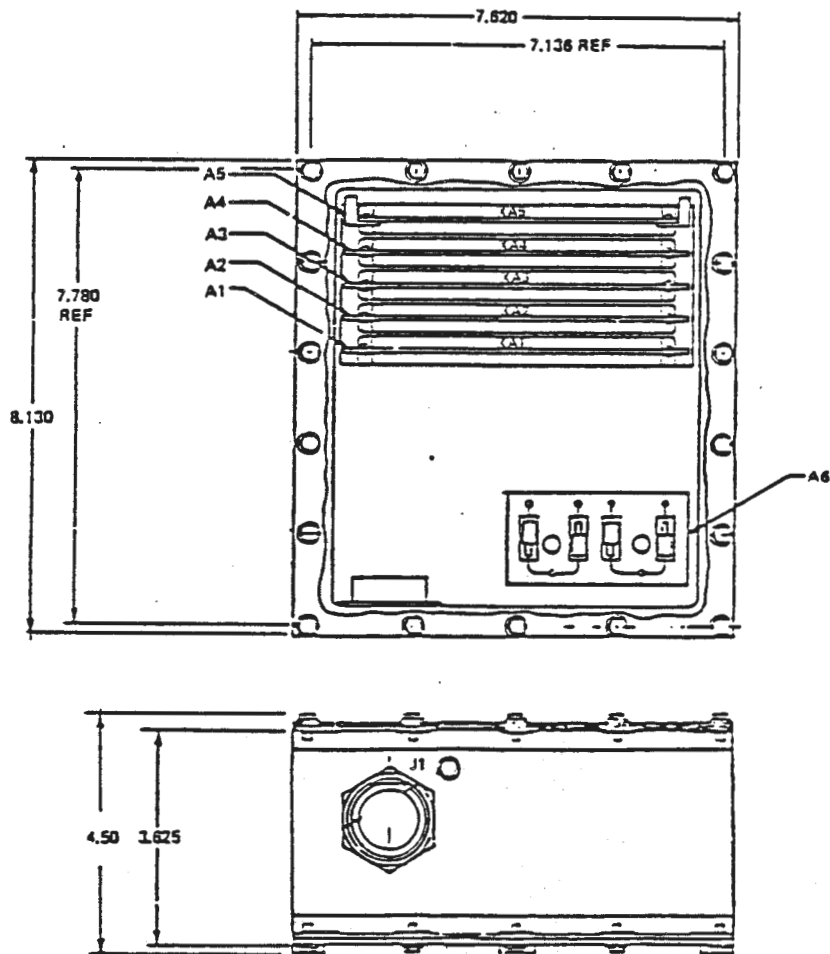

Figure 3-46 Charge Current Controller

The CCC is capable of compensating for battery aging by providing four levels of voltage-temperature on-off control to two relays, K1 and K2. The two channels are independently controlled with separate power excitation and battery reference voltage/temperature inputs. An over-temperature cutoff circuit in each channel removes the charging source at a preset temperature limit for each channel. All CCC modes of operation have command override capability in the event of circuit failure. The four on-off voltage-temperature settings are each selectable by STOCC command. One CCC is provided for each of the six batteries and operate independently of each other.

3.5.4 Power Control Unit (PCU)

The function of the PCU is to control and distribute the electrical power from the SA and batteries to the four Power Distribution Units (PDU). The enclosure is 42.8 x 11.9 x 8.0 in. (including the 2-in. baseplate support that stiffens the large structure). The PCU weighs approximately 120 lb and dissipates approximately 20-25 W, depending on ST load and configuration.

The PCU box is mounted on the rings of the tunnel structure at the back of the SSM equipment section in Bay 4. The PCU interconnects and switches the SA, battery, and charge current controllers and provides the primary bus distribution.

The PCU circuits consist primarily of relays, transfer switches, diodes, current and voltage monitors, bus bars, and a few printed wiring boards with electronic circuitry. The circuits can be divided into the following six categories: SA trim relays, CCC slave and bypass relays, battery reconditioning switching, voltage limiting circuits, bus separation switches and voltage and current monitors.

3.5.5 Power Distribution Units (PDU)

Four PDUs house the buses, switching, fusing, and monitor circuits and are mounted on the interior of the SSM equipment section Bay 4 door. Two PDUs are dedicated to the OTA, SI, and SI C&DH loads, while the others distribute dc power to the various SSM loads.

The PDUs are identical to each other, each is 10 x 5.25 x 17.5 in. and weighs approximately 25 lb and dissipates 1.3 W of electrical power. Each box includes latching relays, non-latching relays, bus bars, diodes, fuses, current sensors, and voltage monitors. Most of the fuses are mounted internal to the box, but fuses in circuits supplying equipment classed as ORU are installed in fuse modules external to the PDU for ease of replacement on orbit. These modules have wing tabs for astronaut use.

Each PDU has six distribution buses. Two buses are supplied from each main bus in the PCU (A1 and A2, B1 and B2, C1 and C2) by two individually fused feeders. Individual circuits are then in turn supplied from an A, B, C, bus through diodes and fuses and supplied to individual user equipment. Some of the circuits include latching or non-latching relays can be operated from ground commands.

3.6 Thermal Control Subsystem (TCS)

The TCS provides thermal control for all subsystem components mounted within the SSM Equipment Section. In addition, the TCS controls the temperatures and gradients of structures that interface with the OTA and SIs and controls the conduction heat transfer through the attachments. General features and requirements of the TCS are:

The TCS provides thermal control for all SSM equipment during all mission phases and is passive to the maximum extent possible. The SSM uses passive thermal control design consisting of insulation, component arrangements, and mounting configurations augmented with thermostatically controlled heaters. White paint or clear anodized aluminum surface finishes are used if possible to meet high emittance requirements for all internal surfaces and components to enhance lighting for on-orbit maintenance. Materials with stable optical surfaces and low contamination are utilized throughout the TCS.

The ST thermal design uses the 398 km (215 NM) orbit and the maximum OTA, SE, and SA power dissipation rates as specified for the hot case condition (time in shadow is taken at 26 min; the sun on the +V3 axis and the maximum solar, albedo, and earth flux consistent with the assumed orbital parameters). The cold case (time in shadow 37 min; sun on -V1 axis and the minimum solar, albedo and earth flux consistent with the assumed orbital parameters) condition uses the 593 km (320 NM) orbit and the minimum power dissipation rates as specified.

The TCS design is configured for sun angles in the range of 50 deg from the +V1 axis to the sun on the -V1 axis (within ± 5 deg roll about the V1 axis). The TCS design will accommodate up to five consecutive orbits with rolls of up to ± 30 deg about the V1 axis after 50 orbits of normal rolls (± 5 deg).

Five-year orbit environment optical surface properties are used for the hot condition and initial surface optical properties for cold condition TCS design. Thermal control surfaces will not be replaced on-orbit. Stable optical surfaces are used.

Low contamination materials are featured and venting provisions in the Multi-Layer Insulation (MLI) are provided with consideration for contamination control. Electrical grounding of thermal insulation and components are provided.

The TCS design is configured to maintain component temperatures within 5°C of the joint qualification/acceptance temperature range for the worst combination of: environmental fluxes, orbit altitudes, ST orientation, eclipse, surface optical properties, and equipment operation. Heater-controlled components have design margins of 25 percent over worst case requirements at the minimum electrical bus voltage.

Thin film Kapton heaters with both primary and secondary elements in the same heater blanket are used for temperature control. The Kapton heaters are adhesively bonded directly onto the component or structure as required. Two thermostats are set nominally 8.3°C (15°F) above the minimum temperature requirements. The two secondary thermostats are set nominally 2.8°C (5°F) above the minimum temperature requirements.

There are several heater circuits for the TCS heaters. Each heater circuit is wired to the A and B electrical buses as well as to a third bus C. Each heater circuit has a second circuit wired to the secondary heater elements with the three A, B, C buses. Each heater circuit can be commanded on or off as well as switched between buses. The commands controlling the heater circuits are identified with the EPS commands. There are no separate commands for the TCS.

The batteries require very close temperature control and must be limited to 25°C maximum during ascent and 10°C maximum on orbit. The minimum temperatures are controlled with heaters set at 0°C with the primary system and -7°C with the secondary system.

The ST thermal design uses passive thermal control augmented by electrical heaters. The design uses stable flight-proven materials and components. The ST uses low absorptivity materials. Either aluminized FEP Teflon or silverized FEP teflon second surface Flexible Optical Solar Reflector (FOSR) is used on most external surfaces. The thermal design concept has been to minimize the effect of the solar energy differences due to variation in sun angle.

The SSM baseline thermal design is illustrated in (Figure 3-47).

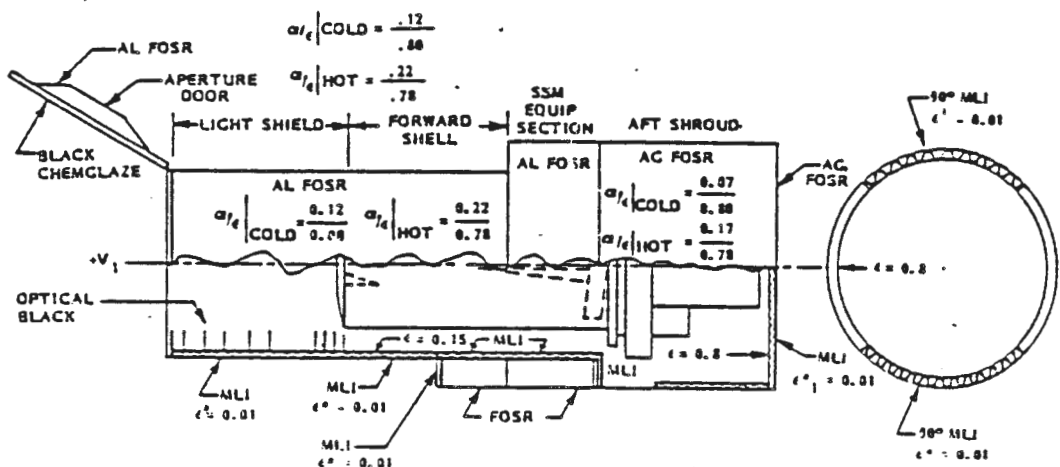

Figure 3-47 SSM Baseline Thermal Design

The LS thermal design meets the OTA interface requirement of an orbital average temperature of between +10°C and -87°C and minimizes thermal distortions. The LS has eight internal baffles for stray light control. The baffles and internal surface of the LS are coated with an optical black paint, Flat Black Chemglaze (Z306), as required by the OTA stray-light analysis. The ratio of absorptivity to emissivity of black paint is 0.95/0.92. The external surface of the LS is covered with Multilayer Insulation (MLI) blankets which have an outer layer of aluminum Teflon (FOSR), 15 layers of 1/3-mil embossed Double-Aluminized Kapton (DAK), and an inner layer of 1-mil DAK. An effective emittance (*) of 0.01 has been used for the MLI blankets. The MLI blankets are mounted on the structure and are part of the meteoroid protection system.

The AD temperatures which interface with the OTA must be maintained between +10°C and -118°C. The surface finish of the door which faces the OTA is a glossy black paint (glossy black Chemglaze Z302) as required by the OTA straylight analysis. The other surface is covered with aluminum Flexible Optical Solar Reflector (FOSR) to minimize temperatures and gradients with full solar heating. The AD is honeycomb structure 1.5 in. thick. The core is aluminum honeycomb (3/8 in. cells, 1.6 lb/ft³, and 1/4-in. cells, 3.4 lb/ft³), and the facesheets are 0.016 in. thick aluminum. The AD has a temperature sensor at the center of the door located on the outer surface. Two additional sensors are placed near the active and passive sections of the AD hinge.

The LS structure consists of integrally stiffened machined skins between stations 455.3 and 568.4, and 0.040 in. thick monocoque skin from there forward (between stations 568.4 and 608.5). The structure has internal rings at each baffle location. The light baffles are 12.75 in. high, resulting in an aperture diameter of 94.5 in. The forward ring at Station 608.5 is painted with optical black paint and has a light baffle attached. There are eight temperature sensors on the light shield structure: four at station 570 and four at Station 494. These sensors are spaced around the circumference of the light shield.

The SSM-ES thermal design is required to; maintain each component within its operational temperature limits, and maintain the OTA/SSM conduction and radiation interfaces below 21°C. Heat rejection from each of the 10 SSM equipment bays is controlled by specified patterns of solar reflecting surfaces (FOSR) and MLI on each door. Heat transfer inboard and through the forward and aft bulkheads is controlled by MLI blankets. MLI is also used to isolate the battery bays and trunnion compartments from the rest of the ES. Bays 1 through 4 are located on the -V3 (shade) side of the satellite and have an average heat dissipation of approximately 140 W per bay. The six +V3 bays have an average component heat dissipation of approximately 60 W each. Bays 1 through 4 are more sensitive to earthshine heating.

There are a total of 17 temperature sensors: six sensors on the forward bulkhead (Station 299) located in bays 2,4,5,7,9, and negative Trunnion Bulkhead, five sensors located in the center of the aft bulkhead station (Station 240) in bays 3,6,8,10 and positive Trunnion Aft

Bulkhead, six sensors located on the radial and axial OTA/SSM attachment fittings at the STA 240 bulkhead. These sensors provide data on structural temperature distributions and verify compliance with SSM/OTA interface requirements. These sensors are isolated from the bays by the internal MLI blankets and will not respond rapidly to local changes in power levels. A total of 12 temperature sensors: six sensor on the tunnel structure and six sensors mounted on the external skins and webs separating the trunnion compartments, will predict temperatures within an accuracy of $\pm 20^{\circ}\text{C}$. Eighteen sensors are used to monitor the temperature of component mounting interfaces. These sensors are located in the internal surfaces of the doors and the component mounting interfaces on the tunnel structure. These sensors will run approximately 5°C to 10°C lower than the corresponding component internal temperature sensors. There are four component temperature sensors in Bay 1: two internal to the DF-224 computer and two internal to the DMU. There are three battery and two oscillator temperature sensors in Bay 2. There are five component temperature sensors in Bay 3, and three battery sensors and two sensors in the DIU. There are no component temperature sensors in Bay 4. A total of 10 component temperature sensors are located in Bay 5: two on each of the Multiple-Access (MA) Transponders and tape recorders and one on each of the S-Band Single-Access (SSA) Transmitters. There are three sensors on each of the two Reaction Wheel Assemblies (RWA) mounted in Bay 6. The two temperature sensors on DIU-4 are the only component measurements in Bay 7. There are 12 component temperature sensors in Bay 8. The location of temperature instrumentation for the RWAs in Bay 9 are the same as in Bay 6. There are two component temperature sensors on the DIU in Bay 10.

The internal 90-deg sections of the AS adjacent to the $\pm V2$ axes use radiation shields to control SI and component effective sink temperatures to their required levels. The internal 90-deg sections of the SA adjacent to the $\pm V3$ axes and the internal surface on the aft bulkhead are covered with MLI blankets. The AS also contains Fixed Head Star Tracker (FHST) and Rate Sensor Units (RSU) which are a part of the SSM Pointing Control Subsystem (PCS). There are eight structural temperature sensors mounted to the SA skin and radiation shields adjacent to the $\pm V2$ axes. These sensors are located opposite the main heat rejection surfaces of the SIs at various axial locations. There are seven temperature sensors located adjacent to the $\pm V3$ axes and three sensors on the Aft Bulkhead (AB). There are 15 temperature sensors mounted on the three RSUs and three FHSTs in the AS.

Finally there are 54 temperature sensors used to monitor external components. These components are elements of the SA, mechanism subsection, HGA, and PCS. The AS has 18 heater circuits to provide thermal control of SSM components. These consist of primary and redundant circuits for each of the three FHST and operational and survival heaters for each of the six gyros.

3.7 Safing System (SS)

The SSM includes a SS which will autonomously protect the ST from electrical power depletion during any 72 hour period when ST Operations Control Center (STOCC) may be out of contact. The SS protects for single failures in any subsystem and permits the ST to survive until STOCC regains contact and control. The SS interfaces with all SSM Subsystems and makes use of many of the Pointing Control System (PCS) and Data Management System (DMS) components. The only "dedicated" safemode hardware is the PSEA which also performs some primary PCS functions. The SS includes the PSEA and makes use of rate gyros, reaction wheels, coarse sun sensors, magnetometers, magnetic torquers and retrieval mode gyros from the PCS. The Data Management Unit (DMU), Data Interface Units (DIUs), DF-224 (Onboard Computer) and flight software are also essential elements of the safing system.

3.7.1 ST Safing System (STSS)

The STSS is structured to operate without ground control for up to 72 hours, but STOCC intervention is required to status the ST configuration, determine the anomaly, reconfigure and resume science operations.

The primary threat to survivability of the ST is the loss of electrical power. The basic strategy behind the ST Safing System is to maintain pointing control, solar array orientation for battery charging and, through use of power load shedding, to conserve electrical power usage. Progressive actions (modes) are employed to permit return to science operation as quickly as possible. The approach is to take the action for a failure that will provide ST safety and yet permit the most rapid return to normal operation. If an unsafe condition persists, the STSS will progress to the next mode that will provide safety though possibly at the cost of time to return to operations.

The STSS detects system level anomalies and takes corrective actions (safe modes) independent of ground control to place the ST in a power positive condition. A safe condition is defined as maintenance of all equipment thermally and in a configuration such that when ground control does intervene, normal ST science operations can be reestablished. The basic ST Safing Requirements within which the ST Safing System has been structured are: autonomously protect ST from power depletion during any 72 hour period with a STOCC outage, two PCS failures will not preclude recovery by the Orbiter.

3.7.1.1 Mode Progression and Sequence

Progressive safing action are employed to permit a return to normal operations in as short a time as possible after fault correction. If a failure is detected that does not immediately threaten ST survival, an inertial hold mode permits maintaining existing attitude and merely suspends science operations. Ground action required to return to normal operations is minimal. If vehicle health deteriorates, the STSS will re-orient solar arrays and the ST axes to point the active surface of the arrays to the sun. The STSS turns off nonessential equipment and maintains a power positive condition, if possible. Recovery from this mode requires additional ground operations.

If STSS is unable to maintain this condition using primary PCS or DMS elements, safing system back-up hardware takes over vehicle control and again attempts to maintain ST safety. Recovery from this condition requires progressively more operations and time. STOCC can, as a last resort, enable transition to an additional non-operational gravity gradient (GG) mode which is used only for contingency retrieval by STS and return to earth following multiple system failures. An autonomous entry capability into GG may also be selected by STOCC. Return to normal operations, though possible (dependent on duration in GG), is not required from this mode. Autonomous safing mode (Figure 3-48) progression illustrates the basic modes of the Safing System.

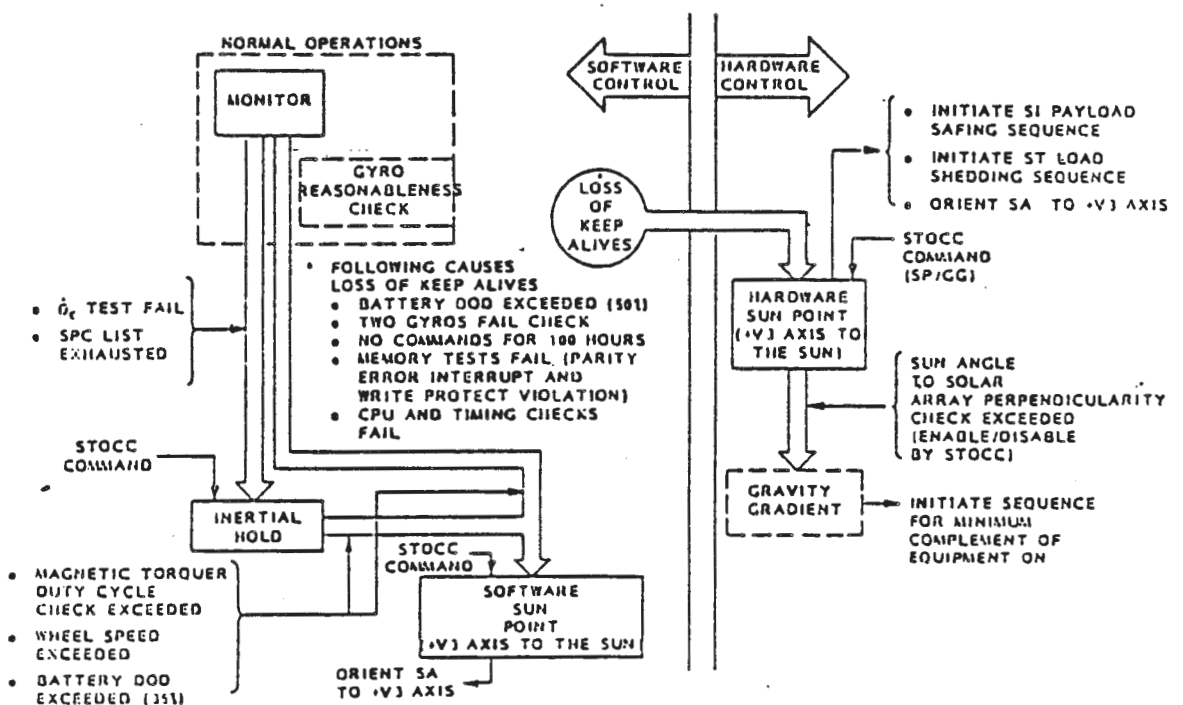

Figure 3-48 Safemode Description, Progression, and Sequence

3.7.1.2 Mode Description

In addition to a routine monitor mode, there are three operational safemodes that can be entered autonomously. These modes are Software Inertial Hold, Software Sun Point Vehicle Mode, and Hardware Sun Point Mode and are described in the following paragraphs. Gravity gradient mode, which cannot be entered autonomously without prior enabling by STOCC, is also discussed.

The Monitor Mode is active during all normal mission operations and encompasses all safing system monitoring functions on-board the ST to autonomously check the ST status. The Safing System may be activated, deactivated, or inhibited by ground command.

The Software Inertial Hold Mode is entered in the event an anomaly is detected during the Monitor Mode. It is initiated when a performance monitor signal threshold is exceeded, or the list of SPCs is exhausted. The ST attitude will be inertially held to the last orientation commanded. If entry occurs during a maneuver, the maneuver will be completed and the safing system will inertially stabilize the ST. No subsequent adjustment in ST attitude is performed and all vehicle rates are damped. The SAs and the HGAs are maintained at the final position commanded.

The Software Sun Point Vehicle Mode is entered upon failure of PCS checks, sun angle check or a marginal electrical power condition. The ST +V3 axis is pointed toward the sun and the SAs are oriented normal to the V3 axis facing the +V3 direction. Constant solar inertial orientation is maintained after the sun point maneuver. ST hardware is maintained above survival temperatures for recovery to normal operations.

The safing system initiates the Hardware Sun Point Mode upon detection of a failure in the DMS or computer software, causing suspension of keep-alive signals. The suspension of keep-alives is caused by battery depth of discharge in excess of 50 percent, or failure of two RGAs or failure in the DMS. When this mode is entered, the Pointing Safemode Electronics Assembly (PSEA) issues discrete commands to remove power from selected equipment, including the DF-224 computer, and activates the Safemode Computer in the PSEA. The "A" bus and "B" bus are separated; the "B" bus and "C" bus are separated. The SSM Processor Interface Table transfer is stopped, which causes the payload safing sequence to be initiated. (Note: The PSEA commands removal of all electrical power to the SI C&DH two hours from mode entry.) After these commands are issued, the PSEA uses rate and attitude information to point the +V3 axis to the sun in a constant inertial orientation. The SA wings are oriented normal to the V3 axis with the active surfaces pointing toward the sun. When the ST is pointed to the sun, the PSEA uses the signal from Coarse Sun Sensor head No 3 for attitude references to maintain sun pointing. Upon attaining the commanded attitude, the PSEA monitors the RGA rates for reasonableness and verifies sun pointing.

In any of the preceding modes, safe survival of the ST can be assured for up to 72 hours without ground intervention, and in most cases longer. If the failure is of such a major nature that even the PSEA Sun Point Mode cannot be achieved or maintained, the ST enters the Contingency Gravity Gradient mode. This mode is a gravity gradient stabilized mode and is not a basic Safing System mode. Unlike the Safing System modes, survival for return to normal operations cannot be ensured without prompt ground intervention and the mission may have to be discontinued.

In this mode, the PMEA issues commands to remove power from selected loads and activates the gravity gradient mode in the PSEA Safemode Computer. Attitude rates are sensed with the Retrieval Mode Gyro Assembly and damped with magnetic torquers. The vehicle is oriented with $\pm V1$ pointing to earth and the V3 axis normal to the orbit plane. When the rates are damped sufficiently, the SAs will be positioned from beta angle input data to maximize power acquisition.

3.7.2 Pointing and Safemode Electronics Assembly (PSEA)

The PSEA (see also section 3.4.1.7) is a part of the ST safing system and its primary purpose is to provide autonomus ST safing in the event of a failure in the DMS, PCS, or EPS subsystems. The PSEA will issue appropriate commands to save the vehicle. In addition to the purely safemode functions, the PSEA provides the electronics to drive the magnetic torquers during normal operations, commands the Mechanism Control Unit (MCU) to close the aperture door if the optical axis approaches the sun line, processes sun angle data for use by the DMS during normal operations and Nadir points the vehicle in GG operation.

The PSEA (Figure 3-49) overall design features a completely redundant electronic unit enclosed in a 9x18x27 in. aluminum dip brazed housing and weighs approximately 86 lb. The unit is completely redundant within the single enclosure and is installed on the tunnel in SSM equipment section Bay 8. The enclosure consists of a machined aluminum based and sandwich constructed sides that have inner and outer aluminum skins and a corrugated core. Twenty-six interface connectors are mounted in the ends of the unit. Electronic components are mounted on 40 electronic printed circuit boards. Top and bottom covers are removable for component access.

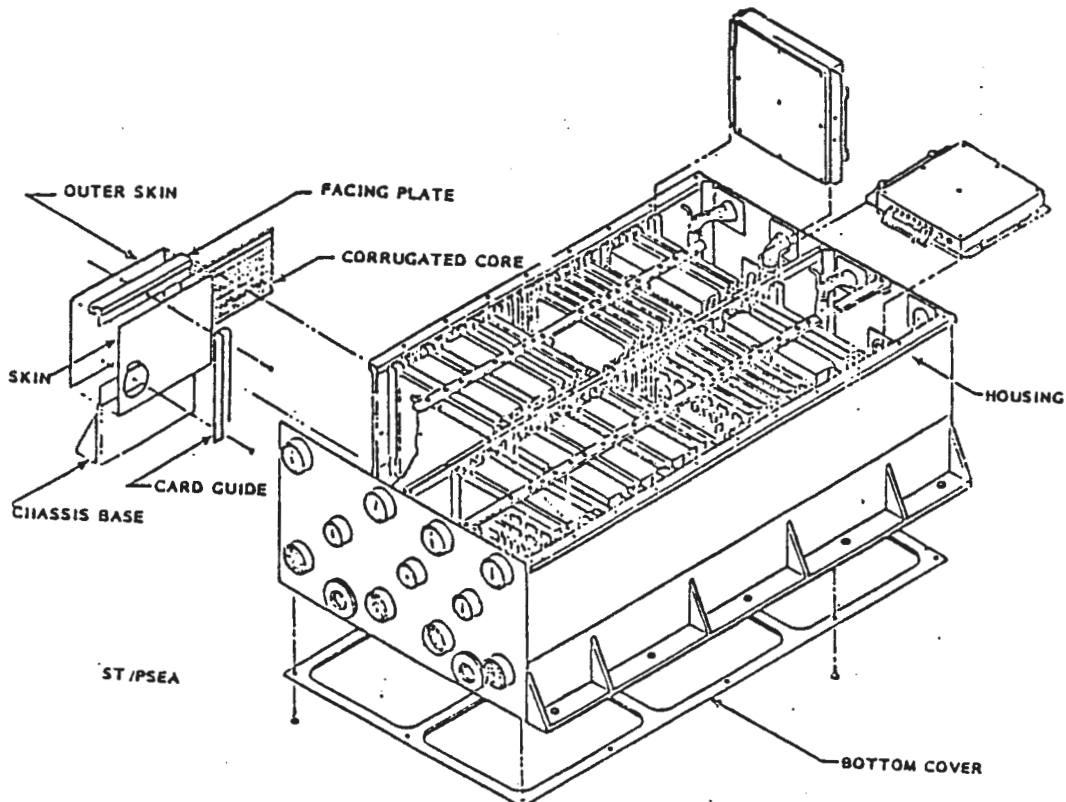

Figure 3-49 Pointing and Safemode Electronics Assembly

4.0 OPTICAL TELESCOPE ASSEMBLY (OTA)

The OTA in Figure 2-6 is the telescope section of the ST spacecraft and includes the following major components:

o Primary Mirror Assembly (4.1) - contains the main ring that is the primary load carrying structure, reaction plate assembly, the main and central primary mirror assembly baffles, and finally the primary mirror.

o Secondary Mirror Assembly (4.2) - contains the secondary mirror subassembly, the secondary mirror baffle, and the metering truss.

o Focal Plane Structure Assembly (4.3) - contains the scientific instruments, fine-guidance/optical-control sensors, the rate gyros, and acquisition star trackers.

o Fine-guidance/optical-control sensors (4.4) supplies fine guidance data for ST vehicle control, and for adjustment of optics in orbit.

o OTA Equipment Section (4.5) - contains most of the OTA electronic components mounted in seven of the nine available equipment bays. Other OTA related electronic boxes and cables are located in the SSM Equipment Section of the ST.

o An exploded view of the OTA subsystems is shown in Figure 4-1. Figure 4-2 is a layout of the OTA and defines the location of the major structural component parts.

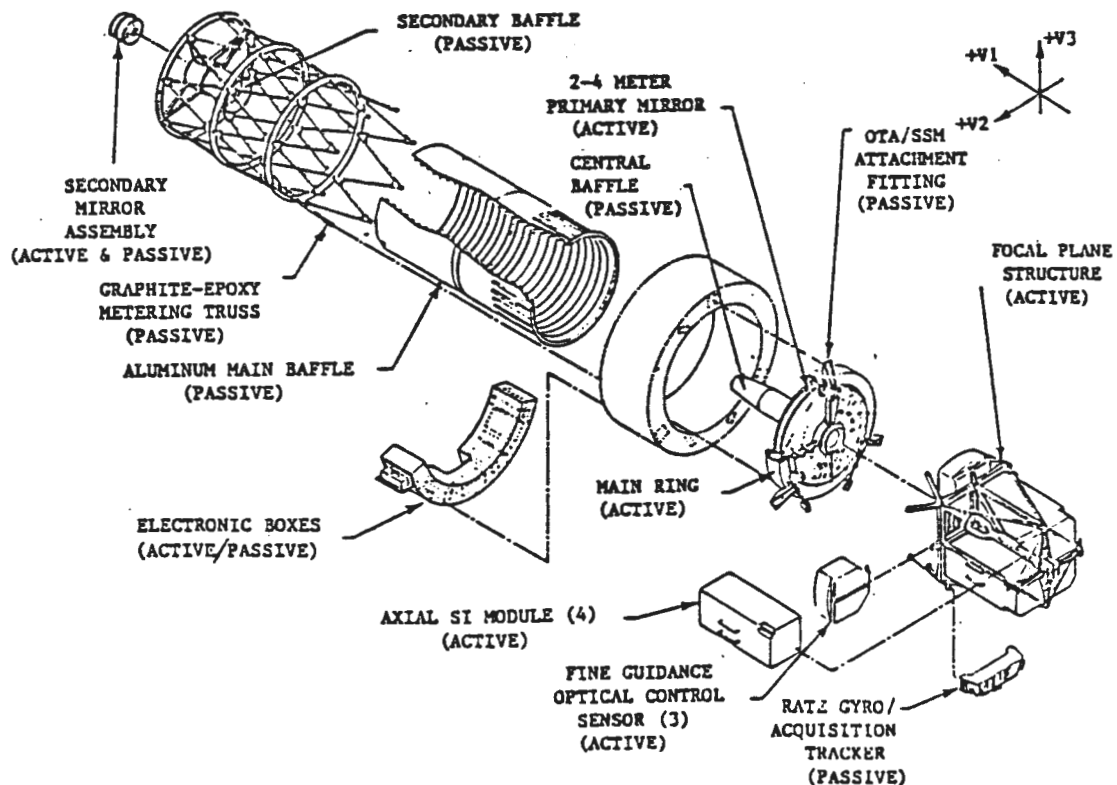

Figure 4-1 OTA Exploded View

- 25 MAIN BAFFLE (A)
- 26 PRIMARY MIRROR
- 27 FIGURE CONTROL ACTUATORS
- 28 AXIAL MIRROR HOUBY (1)
- 29 AXIAL ATTACHMENT LINKS
- 30 FOCAL PLANE ATTACHMENT TRUSS (T)
- 31 FOCAL PLANE DECK (T)
- 32 REGISTRATION DETENT RING (1)

- 17 AXIAL S1
- 18 OVA ELECTROMECHS
- 19 BSH RATE OVRD/STAR TRACKER ASSEMBLY
- 20 BELLONE LIGHT/CONTAMINATION SHIELD
- 21 RADIAL PACKAGE
- 22 REACTION PLATE ASSEMBLY (A)
- 23 MAIN RING (T)
- 24 POLYIMIDE/LENE OXIDE THERMAL SPACER

- 12 CENTRAL SPLINE (A)
- 13 LATCHING MECHANISM CAN ASSEMBLY
- 14 SAFETY CATCH

- 1 MAIN BAFFLE (A)
- 2 PRIMARY MIRROR
- 3 FIGURE CONTROL ACTUATORS
- 4 AXIAL MIRROR HOUBY (1)
- 5 AXIAL ATTACHMENT LINKS
- 6 FOCAL PLANE ATTACHMENT TRUSS (T)
- 7 FOCAL PLANE DECK (T)
- 8 REGISTRATION DETENT RING (1)

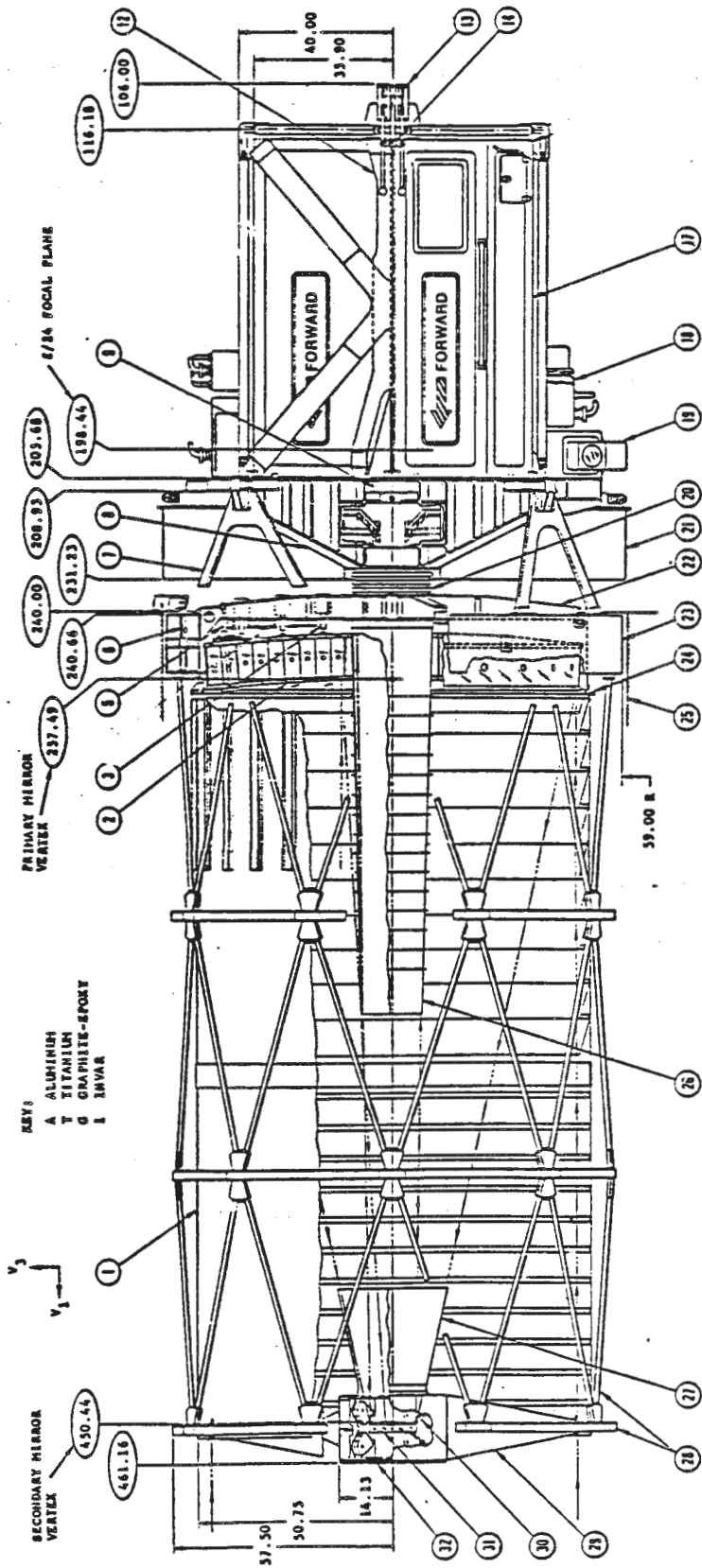

Figure 4-2 OTA Major Structural Components

31 May 1985

The heart of the spacecraft is the OTA where the reflecting f24, Ritchey-Chretien Cassegrain telescope is located. As illustrated in Figure 4-3, this type of telescope features a system where light from a star or other object travels through the aperture, down the assembly past the smaller secondary mirror, and strikes the larger (2.4 m; 94.5 in.) primary mirror. The light is then reflected 4.9 m (16 ft) to the 0.3 m (12.2 in.) secondary mirror where it is narrowed and intensified into a small diameter beam. The beam travels through the 60 cm (24 in.) hole in the primary mirror to the focal plane just behind it. The focal plane is 1.5 m (4.9 ft) behind the front surface of the primary mirror.

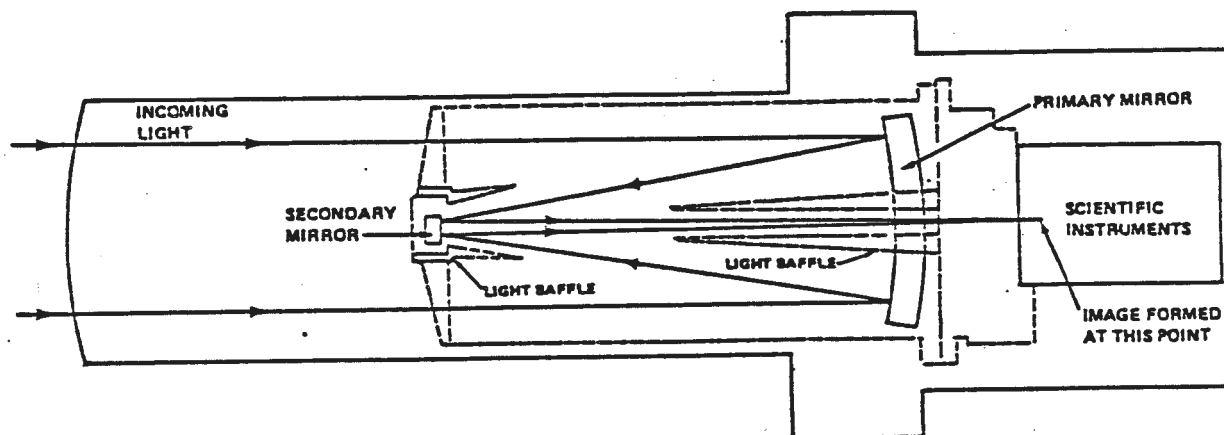

Figure 4-3 Space Telescope Incoming Light Path

At the focal plane the light originally captured by the big mirror is converted into a focused image. This light image is divided among eleven sensing devices; four axial scientific instrument, three optical control sensors, one radial scientific instrument and three fine guidance sensors. Parts of the image that enter the apertures of the scientific instruments are transmitted as data to earth. These pictures and other scientific data are converted to electronic signals and are transmitted via high-gain antennas at a rate up to 1 megabit (one million bits) per second. After being received on earth, the data can be reconstructed into images and spectrograms.

The mirrors will be kept at a nearly constant temperature so that images at the focal plane will have no distortion in their resolution due to environmentally-induced surface changes. Structural stability is required in order to minimize spacecraft orbital thermal distortions affecting the alignment of mirrors and sensors. Three kinds of movement must be compensated: (1) DESPACE, a change between mirrors which defocuses faint objects; (2) DECENTERING, a lateral movement such that PM and SM optical axes even though parallel are not coincident; and (3) TILT, angling of optical axes which produces smearing image.

4.1 Primary Mirror Assembly (PMA)

The PMA (Figure 4-4) consists of the Main Ring (4.1.1), the Reaction Plate Assembly (4.1.2), Primary Mirror Assembly Baffles (4.1.3), and the Primary Mirror (4.1.4).

The overall function of the PMA is to provide the principal OTA optical element and maintain it in an environment such that its optical performance is not compromised. This includes an optimum thermal environment for dimensional stability, the elimination of stray light, a structural cell to support the mirror during launch and retrieval and accurately locate it within the OTA, as well as provide controlled forces to optimize the mirror figure. Two other functions of the PMA are to provide the structural interface between the OTA and SSM, and to provide the structural interface for the OTA Secondary Mirror Assembly Subsystem and the OTA Focal Plane Assembly Subsystem.

The main ring is vented to accommodate the ascent/descent profiles without developing differential pressure loads that would induce structural failure. All cavities are vented to prevent residual pressure bleed-off. Vents are located and oriented to preclude the impingement of vented materials on the PM optical surfaces. Low reflectivity coatings of the main and central baffles minimize out of field of view radiation (straylight).

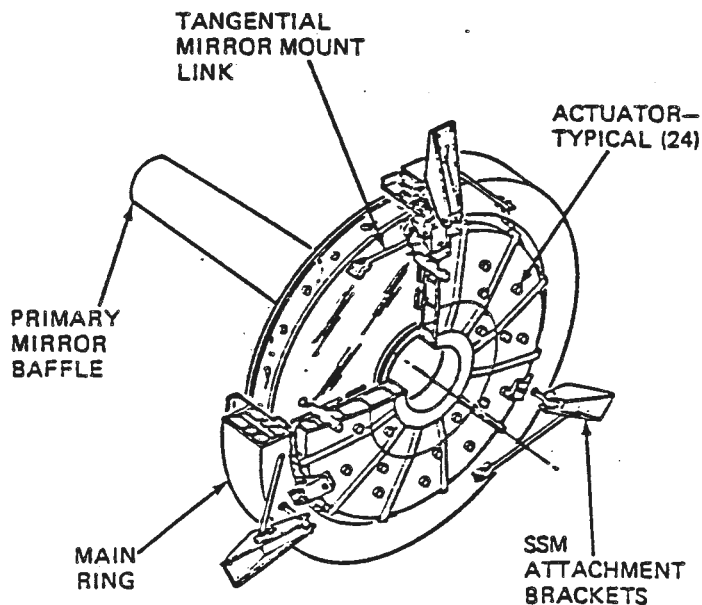

Figure 4-4 Primary Mirror Assembly

31 May 1985

4.1.1 Main Ring (MR)

The MR is the primary load carrying structure to which all OTA subassemblies (Primary Mirror Assembly (PMA), Secondary Mirror Assembly (SMA), Focal Plane Structure Assembly (FPSA), Reaction Plate Assembly (RPA), Axial OTA/SSM Links, Tangential OTA/SSM Links and Main Baffle) are attached. Figure 4-5 is a cross section view of the PMA showing the PM housed within the MR, Figure Control Actuators (FCAs), primary mirror Central Baffle and Reaction Plate Structure (I-Beam).

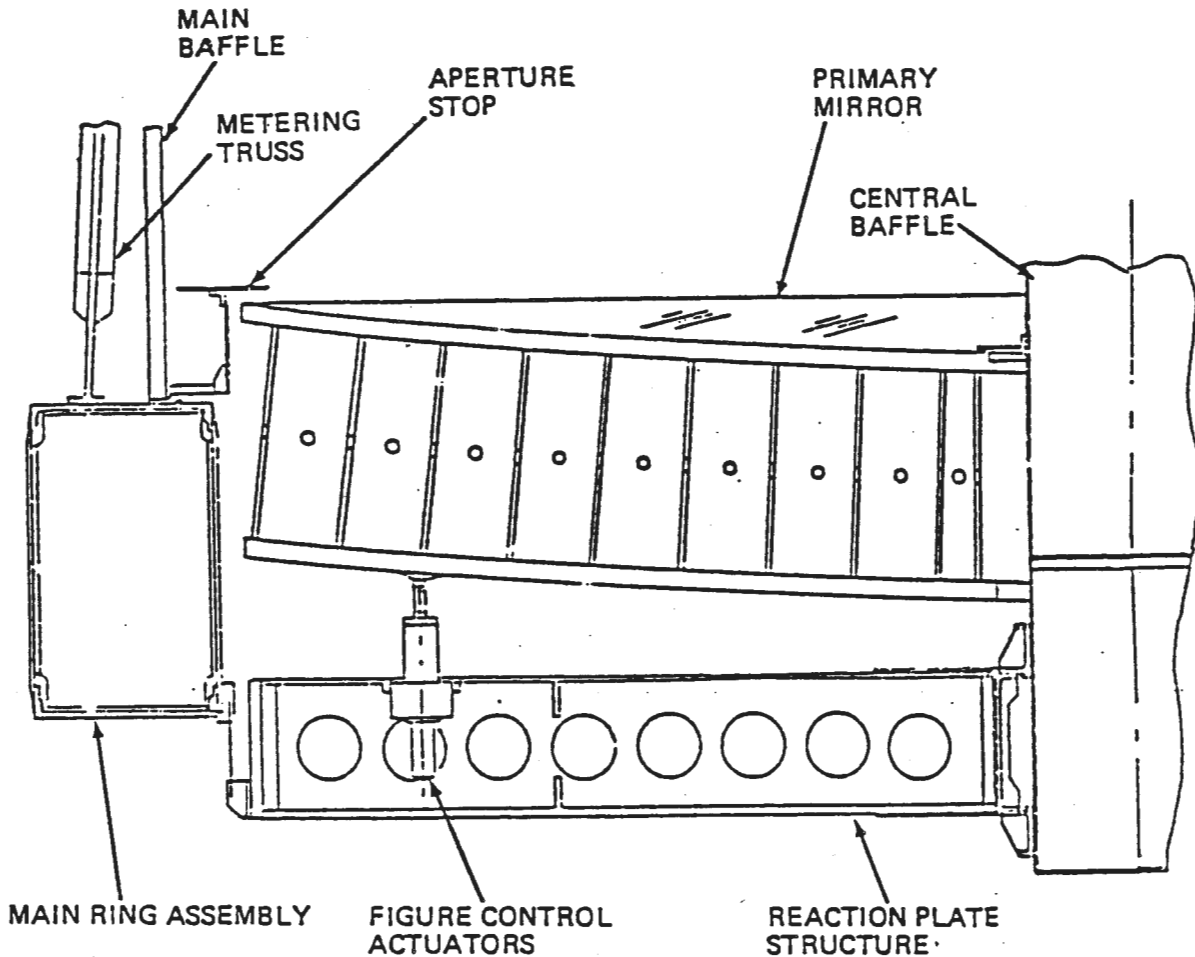

Figure 4-5 Primary Mirror Assembly Cross Section

The MR consists of an annular box beam 118 inch OD x 100 in. ID x 15-in. deep. Included are two concentric cylinders 0.25-in. thick separated by forward and aft channels 0.195-in. thick. Internal fittings have typical thickness of 0.14 in. Cylinders are riveted to channels on OD and ID, forward and aft. Rivets are staggered one degree apart. Internal fittings are riveted to channels and cylinders (all four sides). Internal fittings and outer skins are made of annealed 6AL-4V Titanium. Fasteners are 1/4 in. diameter A-286 flush-head huck bolts.

All OTA/SSM fitting components (axial and shear links), the fittings that attach to the SSM and MR, and the respective attachment bolts, locate the OTA with respect to the SSM.

4.1.2 Reaction Plate Assembly (RPA)

The RPA (Figure 4-6) is attached to the MR by a series of 15 flexure mounts at the RPA perimeter. The RPA provides a reaction support to the figure control actuators which are designed to "distort" the mirror in orbit if required. The maximum plate deflection requirement due to actuator loads is ± 0.0058 in. in the V1 direction at any actuator location.

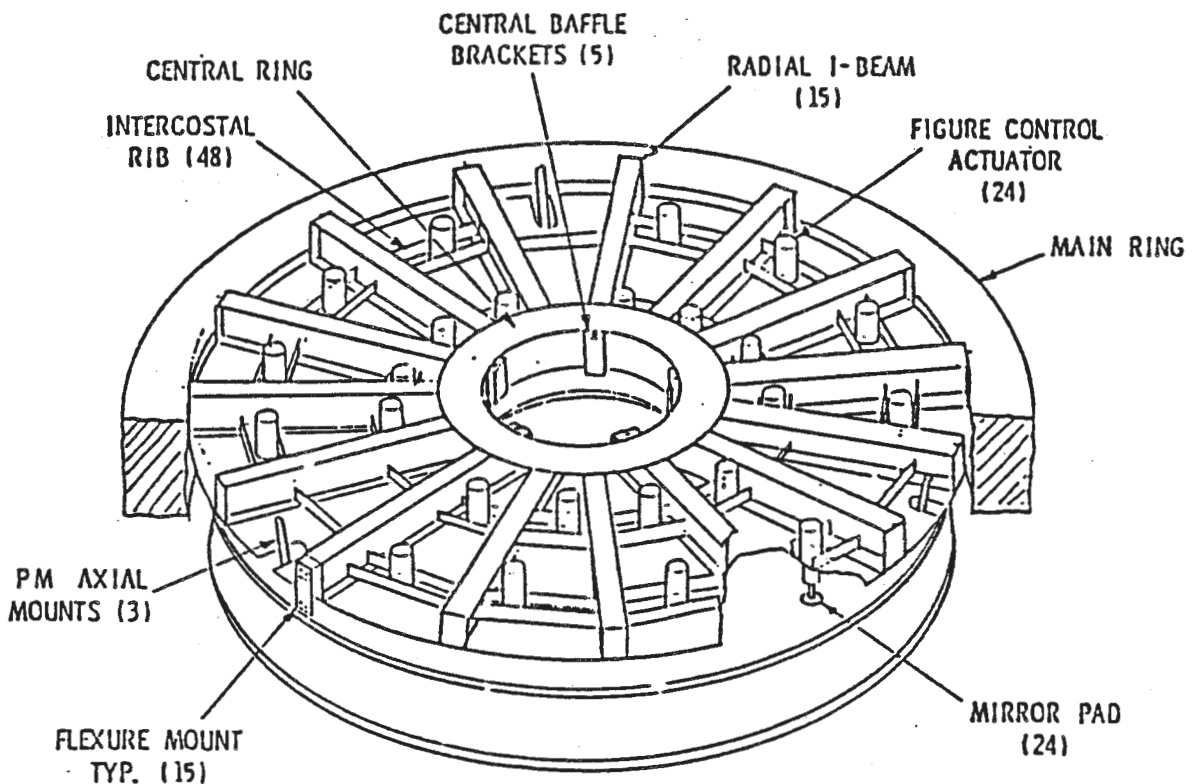

Figure 4-6 Reaction Plate Assembly

4.1.3 Primary Mirror Assembly Baffles

Two Baffle Structures required to provide OTA straylight control are connected to the PMA. Straylight control is a critical baffle performance requirement and is influenced by: baffle geometry, baffle configuration tolerance, baffle edge geometry, and surface reflectivity. The main baffle assembly extends forward from the Main Ring Assembly concentric with and just inside the metering truss assembly. The central baffle assembly extends forward from the RPA through the hole in the Primary Mirror.

4.1.3.1. Main Baffle Assembly (MBA)

The MBA (Figure 4-7) is bolted at 17 points to the MRA forward surface. The Main Baffle will withstand the loads induced by the OTA Aperture Cover (40 lb maximum weight) when the forward (+V1) end of the Main Baffle is supported by its attachment points to the Main Ring. The Main Baffle withstands loads imposed on it by in-plane and out-of-plane deformations of the MRA acting simultaneously with the Main Ring.

The interior of the Main Ring shell and the surfaces of all internal baffles are finished with Chemglaze Z306 flat black paint. The 12 Aperture Cover fittings are black anodized.

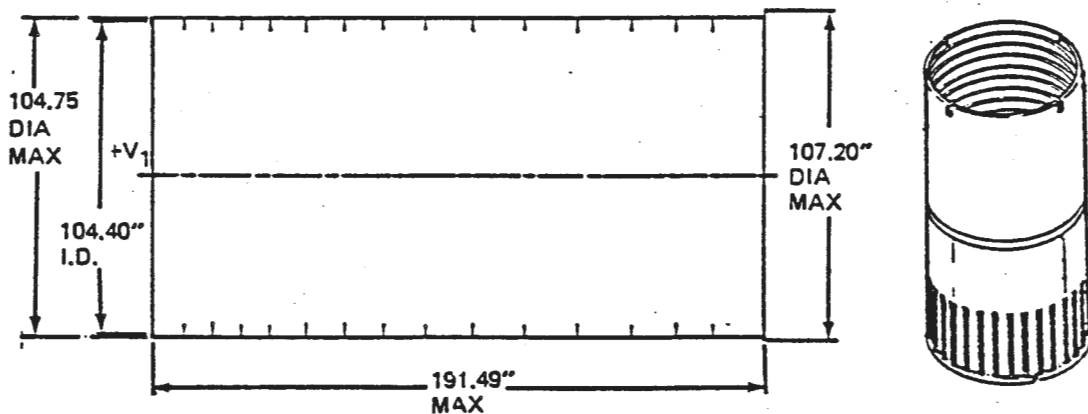

Figure 4-7 Main Baffle Assembly

4.1.3.2 Central Baffle Assembly (CBA)

The CBA (Figure 4-8) is bolted at five equally spaced points on the forward and aft surfaces at the Main Ring Reaction plate subassembly. The weight of the Central Baffle is 34 lb maximum. All surfaces of the Central Baffle structure except the interface surfaces of the mounting flanges are finished with 3M401-C10 flat black.

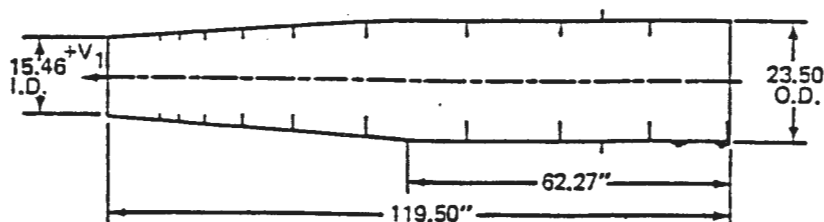

Figure 4-8 Central Baffle Assembly

4.1.4 Primary Mirror (PM)

The PM (Figure 4-9) is a sandwich construction with a back plate, front plate, and edgebands fused together. Mirror material is of Ultra Low Expansion (ULE) glass by Corning. Glass is 92.5 percent SiO₂ and 7.5 percent TiO₂. The PM is 2.4-m diameter hyperboloid 11.04-m radius. The mirror surface is vacuum coated with 650 Å aluminum and 250 Å of magnesium fluoride (MgF₂). The MgF₂ boosts ultra-violet wavelength through interference effects and protects the underlying aluminum layer. The minimum reflectivity of the PM is 70 percent at 1216 Å and 85 percent at 6328 Å.

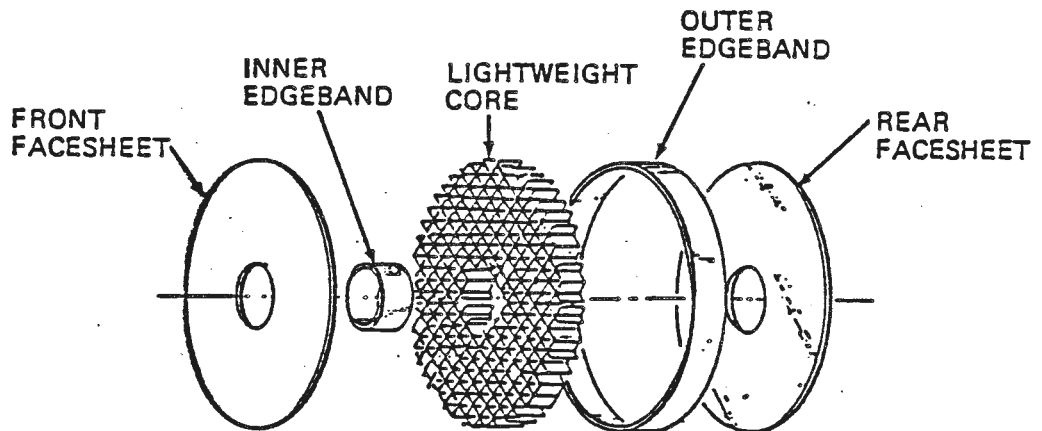

Figure 4-9 Primary Mirror Construction

4.2 Secondary Mirror Assembly (SMA)

The SMA (Figure 4-10) consists of the Secondary Mirror Subassembly (SMSA), the Secondary Mirror Baffle (SMB), and the Metering Truss Structure.

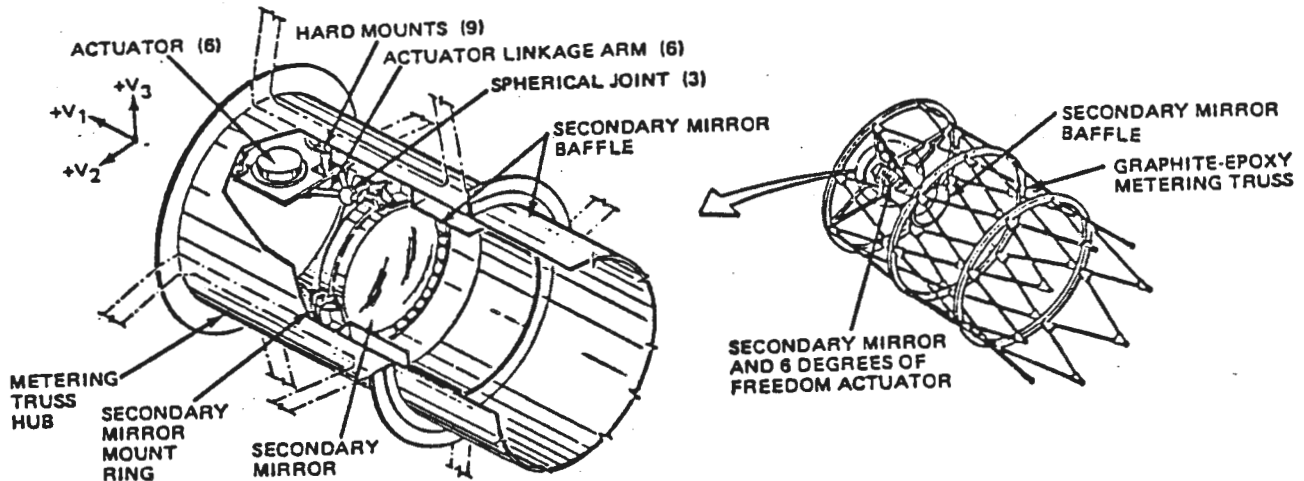

Figure 4-10 Secondary Mirror Assembly

4.2.1 Secondary Mirror Subassembly (SMSA)

The SMSA (Figure 4-11) contains a 0.31-m diameter convex mirror that is composed of Zerodur Glass and coated with Al and MgF2 as PMA. The secondary mirror reflects and focuses the light from the primary mirror through the central baffle to the focal plane. The SMSA also contains actuators and links, actuator mounting plates, shrouds between plate and +V1 cover, thermal control components, control and diagnostic instrumentation and secondary mirror support structure. The SMSA has attached a light baffle.

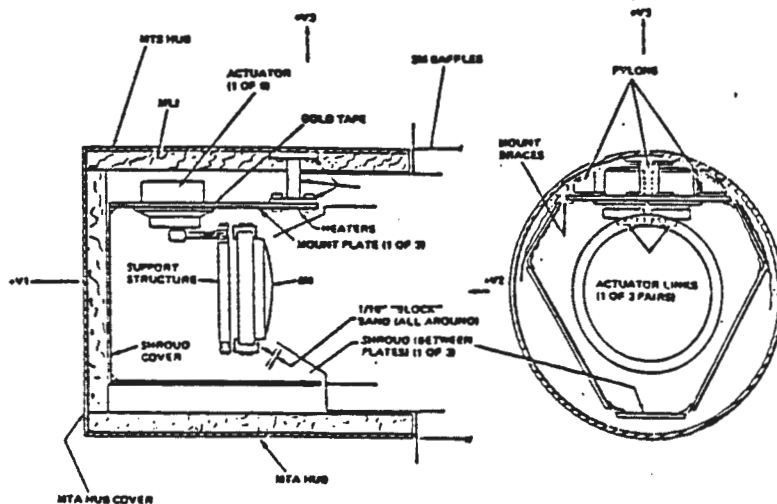

Figure 4-11 Secondary Mirror Subassembly

4.2.2 Secondary Baffle Assembly (SBA)

The SBA (Figure 4-12) extends rearward from the Metering Truss Assembly (MTA) central cylinder and is nominally concentric with the OTA secondary mirror. A baffle is also located on the forward surface of the MTA central cylinder. The baffle structure weight including weights of required standoffs is 15 lb maximum and the structure is an inseparable assembly. Loads from the contraction of the SM baffle from room temperature assembly condition and on-orbit thermal variations are accommodated by a radially compliant mounting scheme to prevent loads from being induced into the metering truss hub that cause MTA out-of-specification performance. For purposes of designing the SM baffle/standoff mount, the radial spring rate of the standoff is 50 lb/in. maximum. Baffle edge configuration locations and coating are paramount concern in the OTA straylight control design. All surfaces of the secondary baffle structures except the interface surfaces of the mount channel are finished with 3M401-C10 flat black paint.

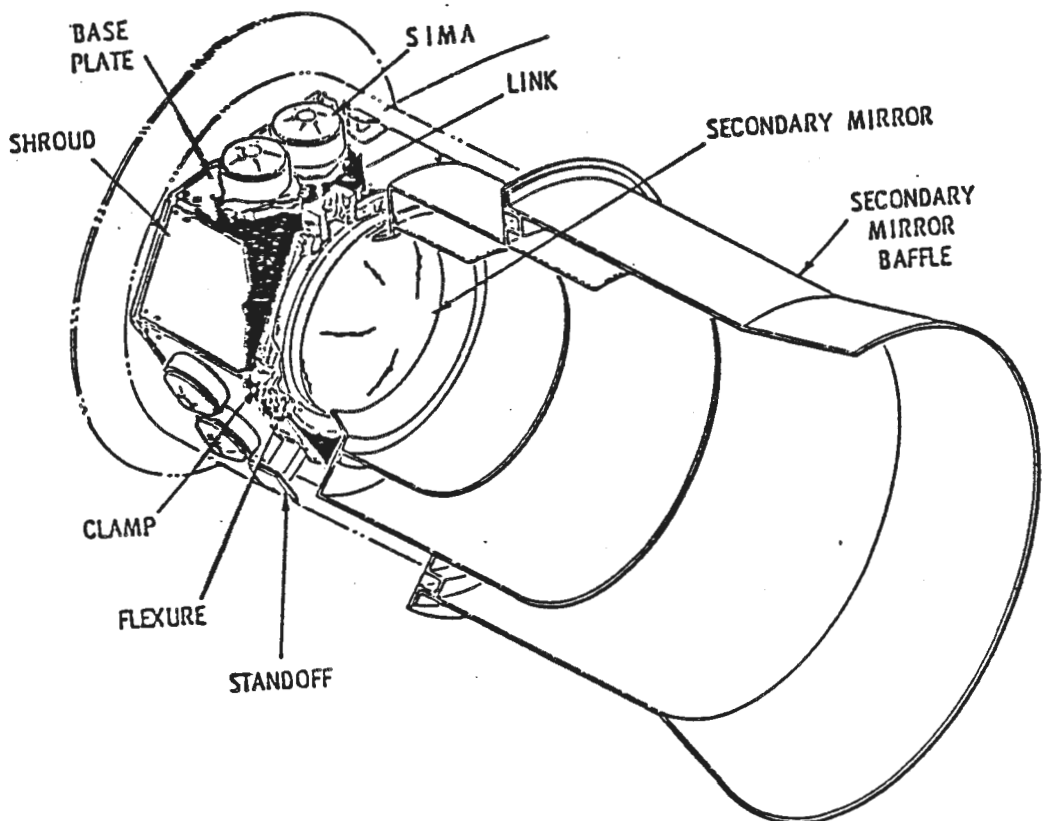

Figure 4-12 Secondary Mirror Subassembly and Baffle

4.2.3 Metering Truss Structure

The Metering Truss (Figure 4-13) is a graphite-epoxy truss/ring structure that separates and supports the main ring and the SMSA. It is called a "Metering Truss" because it exercises dimensional control in a thermally dynamic environment. The truss is required to maintain the following dimensional control between the PM and SMA: DESPACE limited to 118 microinches, DECENTER limited to 394 microinches, TILT limited to two arcseconds. The 4.9 Meter Structures consists of 48 tubular elements (@ seven feet long). The truss structure is thermally passive (no heaters). Graphite epoxy material tubular elements are selected according to their measured coefficients of expansion positions in the truss are assigned by matching with the expected temperature variation.

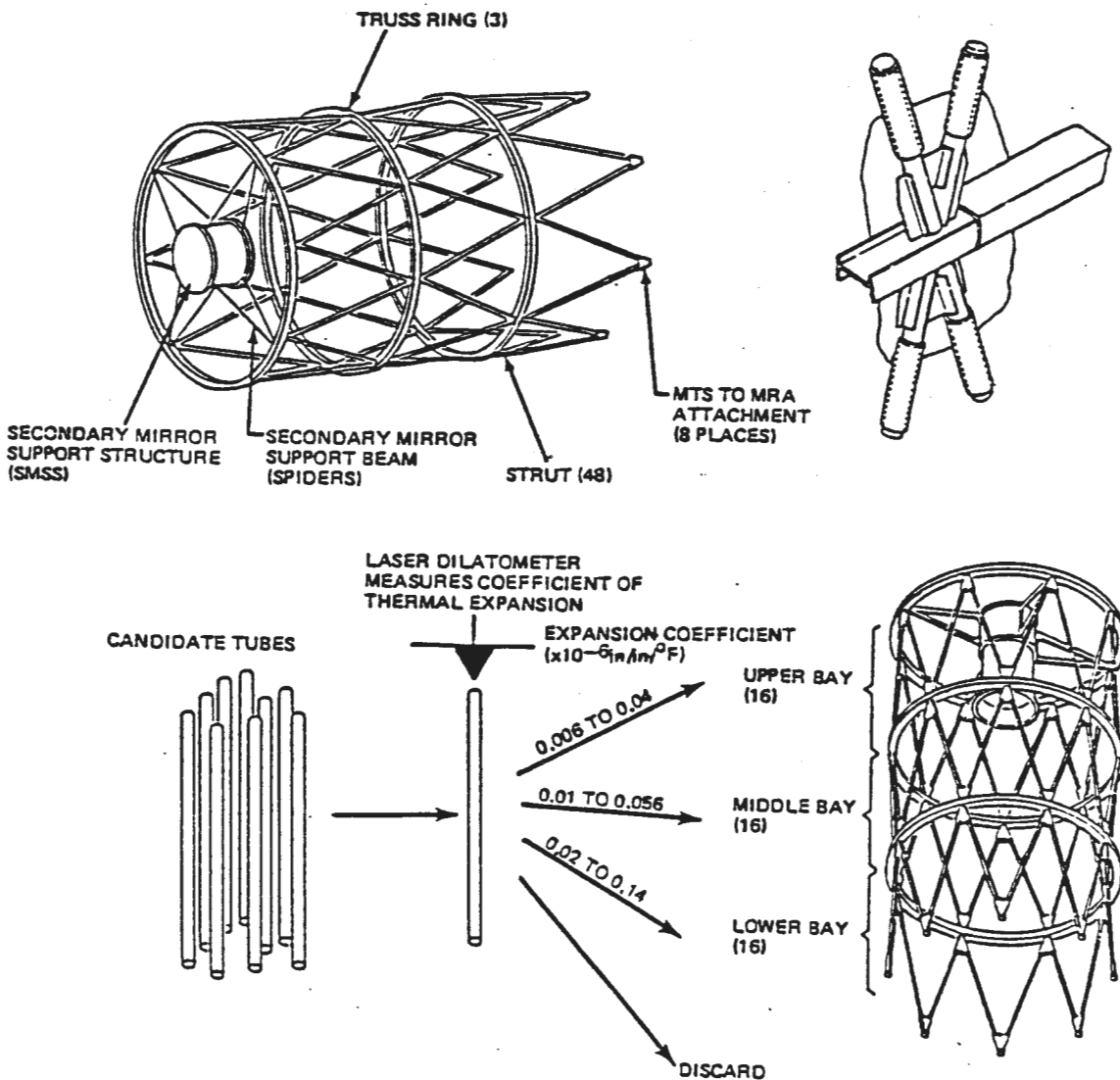

Figure 4-13 Metering Truss

4.3 Focal Plane Structure Assembly (FPSA)

The FPSA (Figure 4-14) provides integrating structure that supports: five Scientific Instruments (SIs), three Fine Guidance Sensor/Optical Control Sensor (FGS/OCS) modules, and a SSM-Equipment Shelf (SSM-ES) that in turn supports three Fixed Head Star Trackers and three Rate Sensor Units.

On orbit, the principal function of the Focal Plane Structure (FPS) is to maintain the pointing alignment of each of the five SIs, relative to the three FGSs. To maintain pointing alignment the FPS structure is primarily composed of graphite epoxy material that is thermally actively controlled by heaters. The major structured mounts are metallic with Invar and annealed 6Al-4V titanium fittings designed for low stress levels.

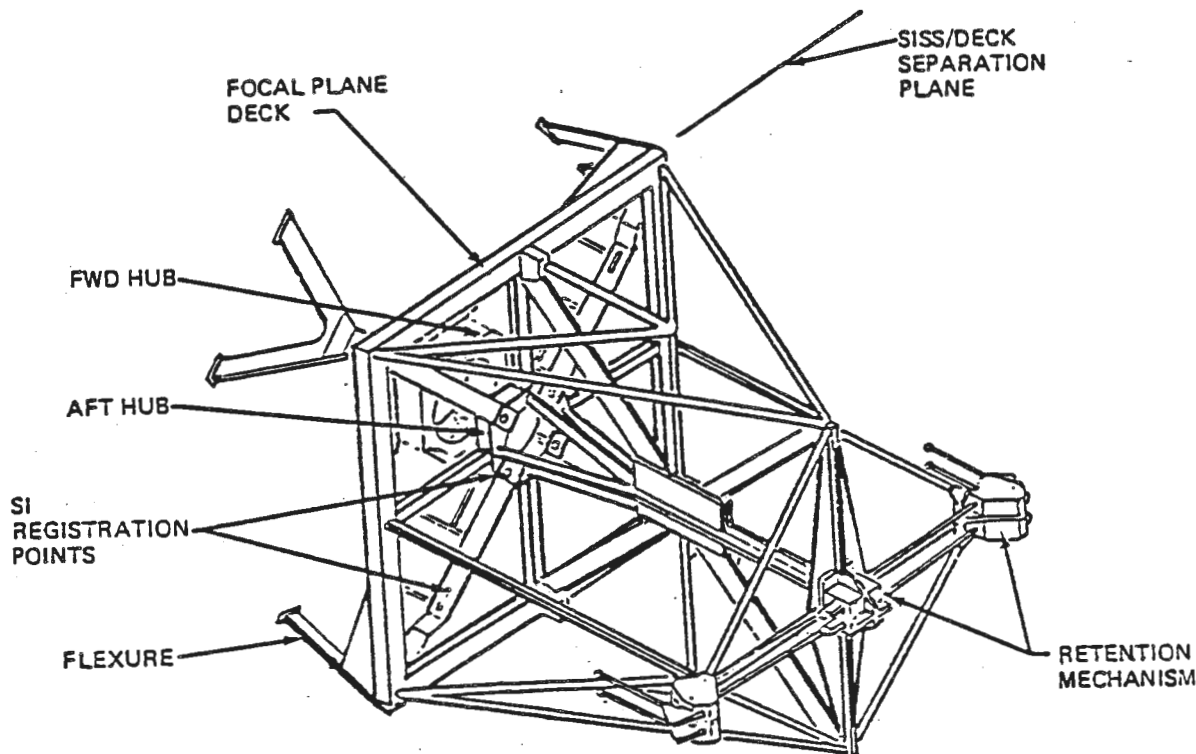

Figure 4-14 Focal Plane Structure Assembly

The FPSA consists of two-piece separable assembly consisting of the Focal Plane Deck Assembly (FPDA) and the Scientific Instrument Support Structure (SISS). The FPSA incorporates provisions for mounting: the radial SI (WF/PC), radial positioned FGSs, and axial SIs. The FPS interface with the telescope is at the aft face of the Main Ring Assembly (MRA) at Station 240.66.

4.3.1 Focal Plane Deck Assembly (FPDA)

The FPDA consists of the central hub and beam structure, and the deck to MRA flexures. All interfaces with the FGS modules and the radial SI (WF/PC) are contained within this assembly. The forward interface attachments and the rotation stabilizer and caging mechanism for the axial SIs, forward supports for the SSM-Equipment Shelf (SSM-ES), axial and radial bay guide rails, personnel tethering and the radial SI connector panel bracket also interface with this deck.

The FPDA interfaces the Main Ring (MR) at eight points (by four "bi-pod" flexures). These flexures are designed to accommodate radial displacements associated with thermal expansion or contraction of the titanium MR. The flexures are graphite-epoxy, with titanium "boots" for the MR interface.

4.3.2 Scientific Instrument Support Structure (SISS)

The SISS supports the aft end of the axial SIs in the lateral directions. The connection (i.e., load path) from this truss to the SIs is through a preloading device physically attached to the truss. Also attached to the truss are the aft guide rails for the axial SIs, cables, indicators and aft support for the SSM-ES.

4.3.3 Mounting Constraints

Figure 4-15 shows the mounting arrangement of the radial SI (-V3 bay) and the three FGS/OCS modules (+V3 and ±V2 bay) and the direction of constraint for each fitting. The line of force of the stabilizer fittings from the OTA centerline are as shown. Detailed descriptions are provided in ST-ICD-02 and 03.

The radial SI is supported and constrained at three points. Statically determinate constraints applicable to each of the three points are as follows:

| Point | Direction |
|-------|-------------|
| A | ±V1 ±V2 ±V3 |
| B | ±V1 |
| C | ±V1 ±V2 |

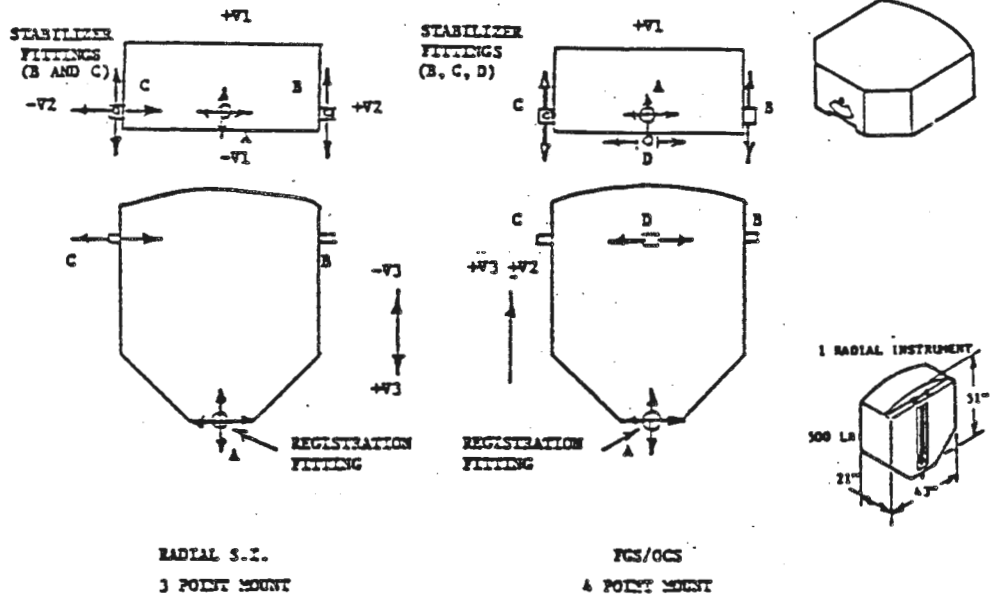

Figure 4-15 Radial Bay Mounting Arrangement and Constraints

The three axial SI attachment points (latch constraints A, B & C) are shown in Figure 4-16. This figure shows the mounting arrangement of the axial SI in all four axial bays and the direction of constraint for each fitting. Point "A" is restrained in V1, V2, and V3 directions. Point "B" is restrained in V1 direction. Point "C" is restrained in V1 direction for FGS, and V1 and V2 direction for WF/PC. The FGS has an additional point "D" which is restrained in V2 (FGS2) and V3 (FGS1 and FGS3) directions.

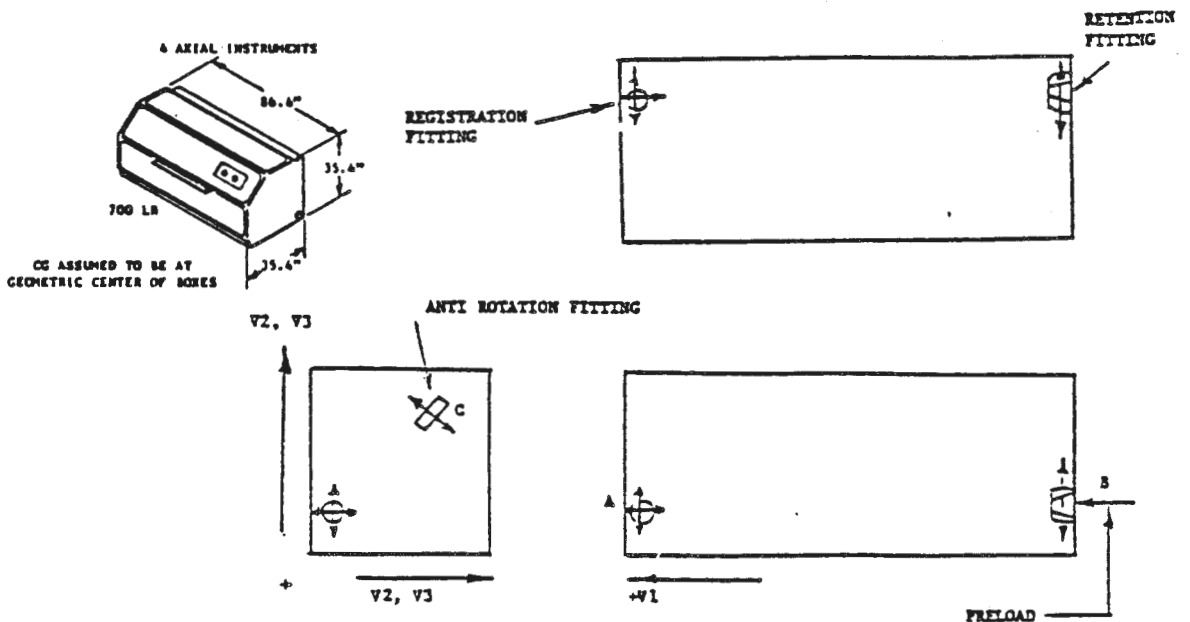

Figure 4-16 Axial SI Mounting Arrangement and Constraints

4.3.4 SSM-Equipment Shelf (SSM-ES)

The SSM-ES assembly (Figure 4-17) is located on the -V3 and aft side of the FPS. The FPS supports the 425 lb SSM-ES including the SSM Fixed Head Star Trackers (FHSTs) and the Rate Sensor Units (RSUs) equipment.

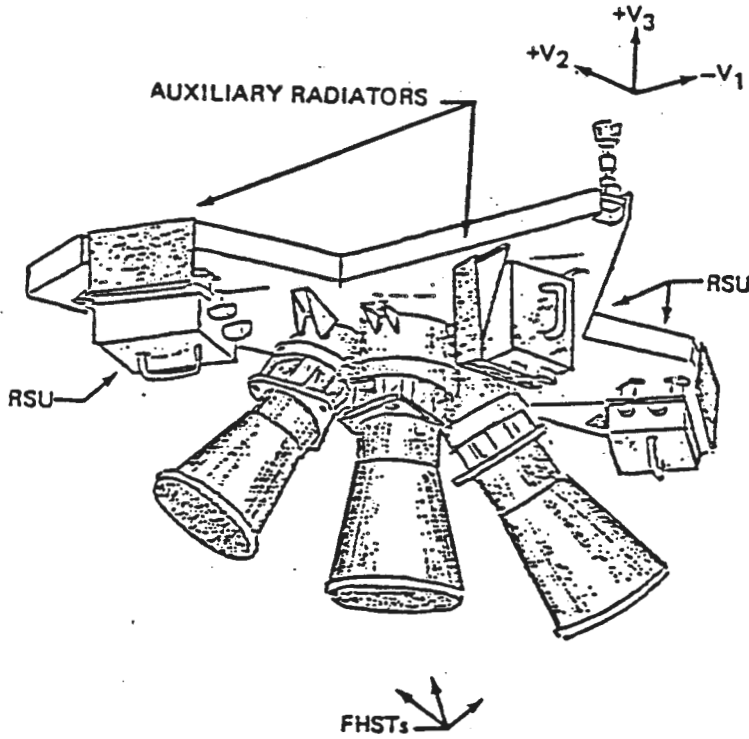

Figure 4-17 SSM-Equipment Shelf

The SSM-ES is a graphite epoxy, four inch thick composite structure consisting of top and bottom panels and egg crate core. The shelf is mounted to FPS by three kinematic mounts. The RSU and FHST mounts are of graphite epoxy. Constraints are shown in Figure 4-18.

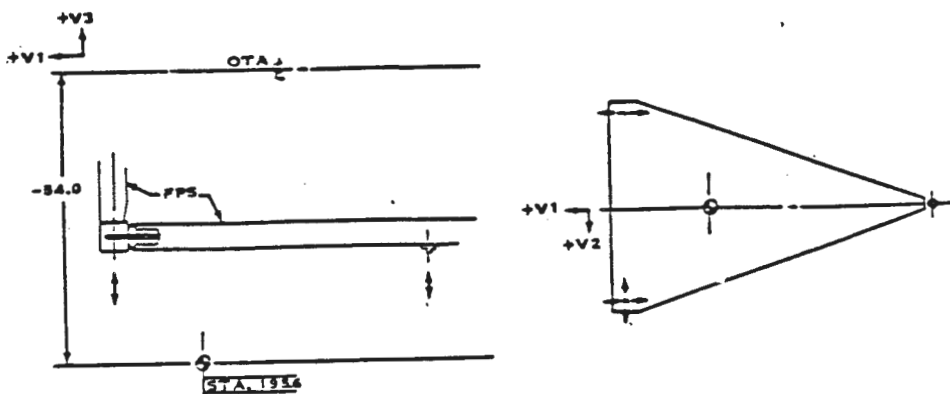

Figure 4-18 SSM-Equipment Shelf Mount Constraints

4.4 Fine Guidance Sensor (FGS)

The cutaway view (Figure 4-19) of the FGS (see Section 3.4.1.1) shows the both the optical and mechanical components in their relative locations. Each FGS contains some 22 optical components, such as mirrors and lenses, along with the two Koesters prisms and four photomultiplier (PMT) tubes.

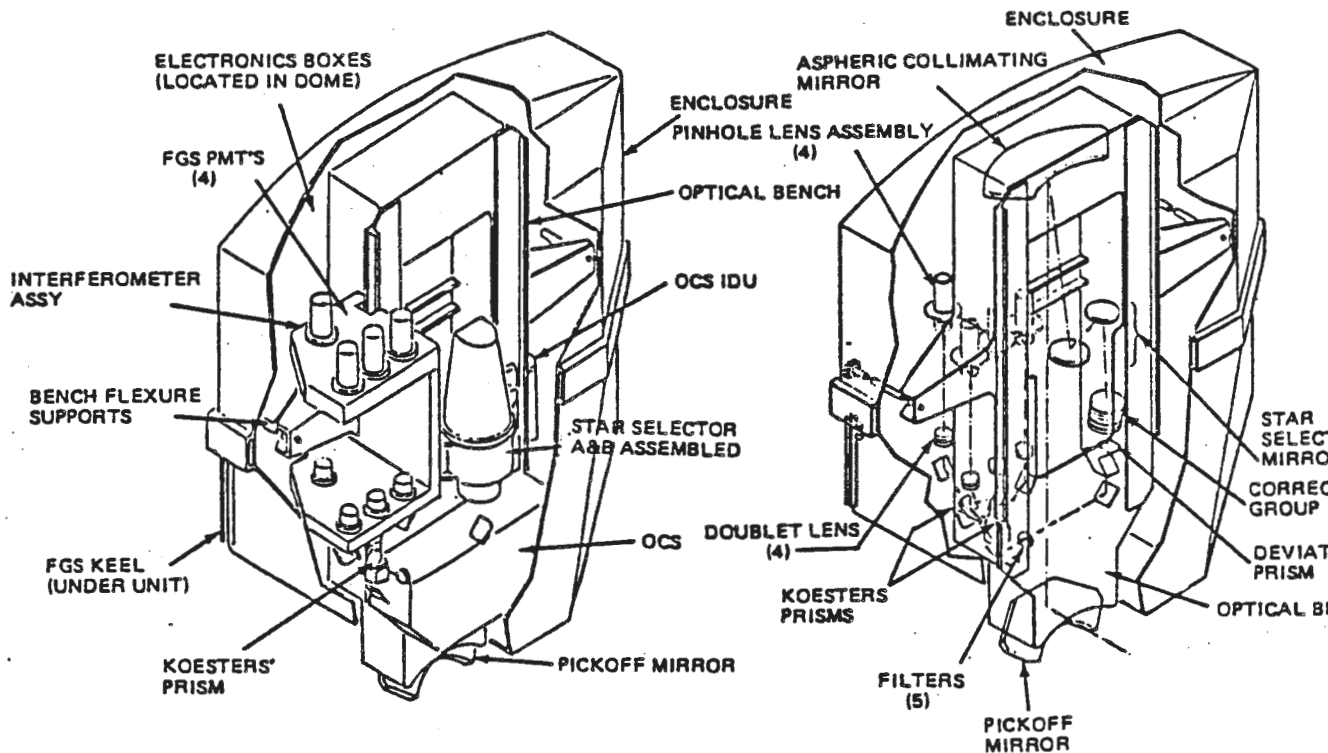

Figure 4-19 FGS Optical and Mechanical Arrangement

Figure 4-20 is a simplified optical schematic showing the function of each component. The FGS will output angular measurements in two orthogonal axes.

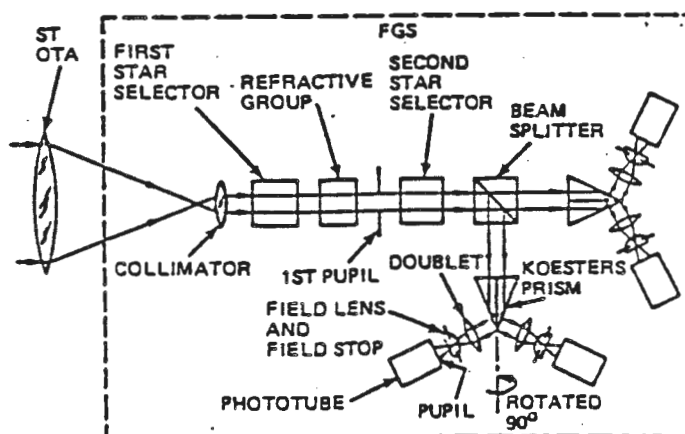

Figure 4-20 Fine Guidance Sensor Optical Schematic

31 May 1985

The following discussion traces the optical light path through the FGS: Referring to Figures 4-19 and 4-20, the starlight passed through the primary optics and reaches the focal plane. The FGS total field of view is shown in Figure 4-21.

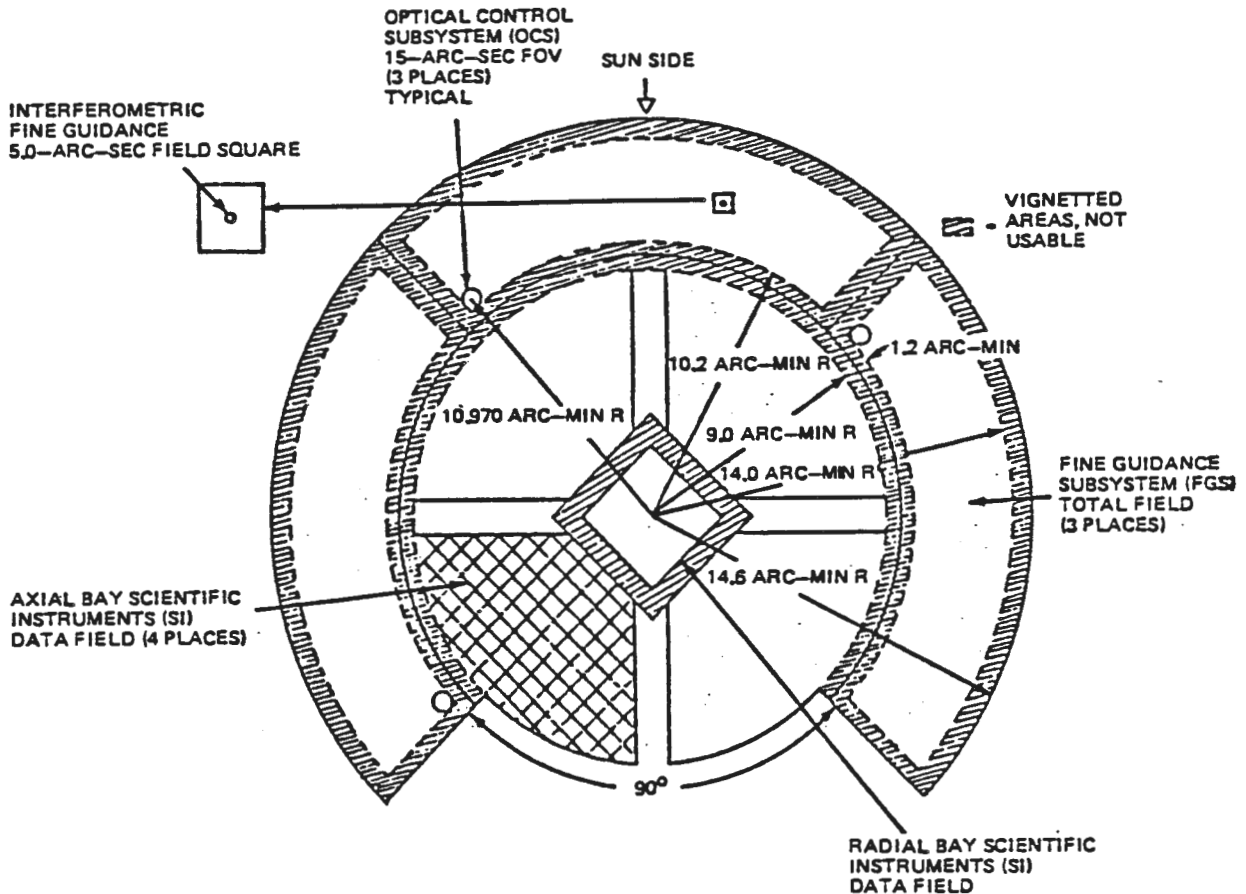

Figure 4-21 Space Telescope Focal Plane

The light is then reflected from the FOV of the main optics into the FGS by the pickoff mirror to a aspheric collimating mirror that is effectively placed behind the focal point of the primary optics. The collimator, in making the diverging light rays parallel, achieves an angular gain of 57.25 (the ratio of the primary focal length to the collimator focal length). In other words, if a star moves one arcsec across the FOV of the primary optics, the light exiting the collimator will show an angular change of 57.25 arcsec.

The light then enters the first Star Selector, a cylindrically shaped unit containing two mirrors and a refractive group of lenses. The whole cylindrical unit is then rotated for Star Selection, positioning the A vector as shown in Figure 4-22.

STAR SELECTOR SERVOS, A AND B,
POSITION THE 5 X 5 ARC SEC SENSOR
FIELD OF VIEW WITHIN THE FGS FIELD
OF VIEW AS DEFINED BY FGS PICKOFF
MIRRORS

PHOTO MULTIPLIER TUBES DETECT
RADIANT ENERGY THROUGH THE
KOESTER PRISMS. PMT COUNTS ARE
PROCESSED TO PROVIDE INTERFER-
OMETER SIGNALS ALONG THE TWO
NARROW SENSITIVE SLITS OF THE
5 X 5 FOV

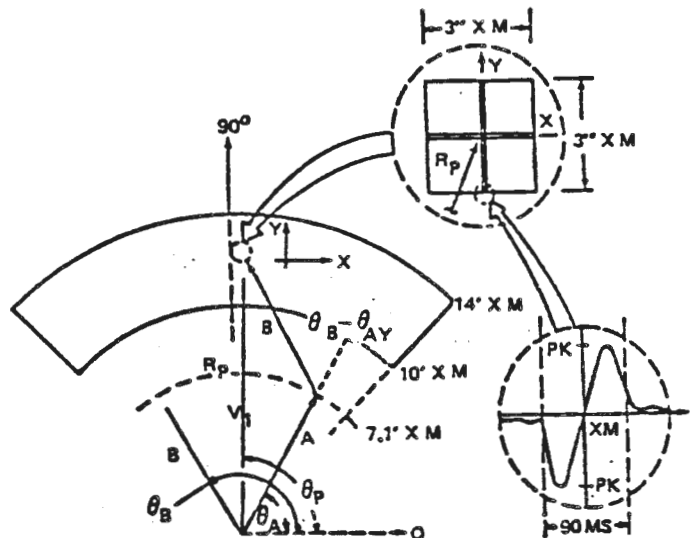

Figure 4-22 FGS Field of View Description

Following this, the light enters a second Star Selector which uses a modified double rhomb prism instead of mirrors. This Star Selector can be rotated independently of the first Star Selector, and corresponds to the position of the B vector in Figure 4-22. By adjusting both Star Selectors, the line of sight of the instantaneous FOV can be maneuvered anywhere in the 60 arcsec squared FGS FOV. These two Star Selectors are the only moving parts in the FGS.

The light is then passed through a bandpass optical filter, and a beamsplitter. The beamsplitter separates the light for the two independent x-y measurements and polarizes the light for the Koesters Prism. The interferometer with Koesters prisms and final optical stages is shown in Figure 4-23.

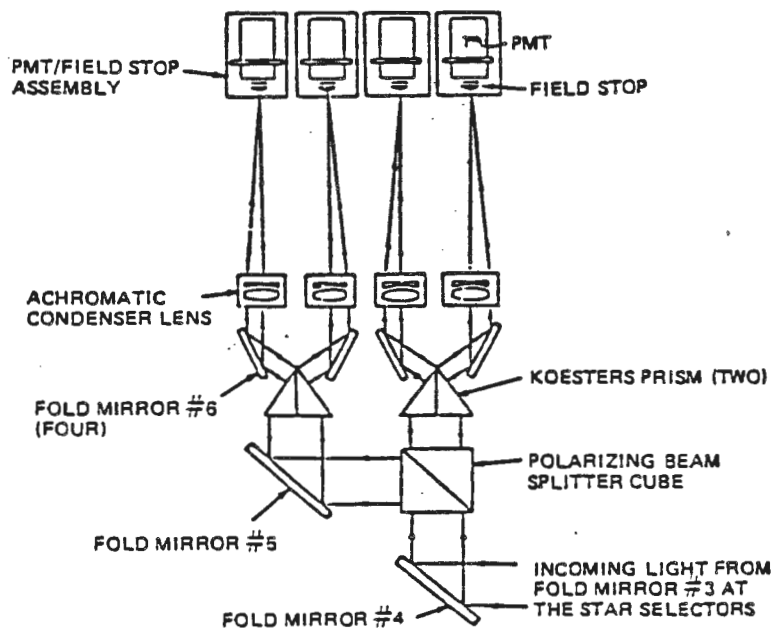

Figure 4-23 Interferometer Optical Assemblies

The optical interferometer is a Koesters prism made up of two right angle prisms adjoined at a coated semi-reflective surface which reflects half of the light energy that strikes it, and transmits half of the light through the interface with a quarter wave (90 deg) phase lag. Figure 4-24 shows the Koesters prism with a planar light wave impinging parallel to the prism face. Points A, B, and C represent the same point on the sinusoidal light wave, e.g., the peak. As ray (A) enters the prism, it is reflected and strikes the semi-reflective surface. The portion of light that has lagged 90 deg and passed through is (A'), and (A'') is the sinusoidal peak of the portion that is reflected back. The rays (A') and (A'') then exit the prism. A ray entering on the exact opposite side of the prism (point C) does the reverse, as shown in the figure.

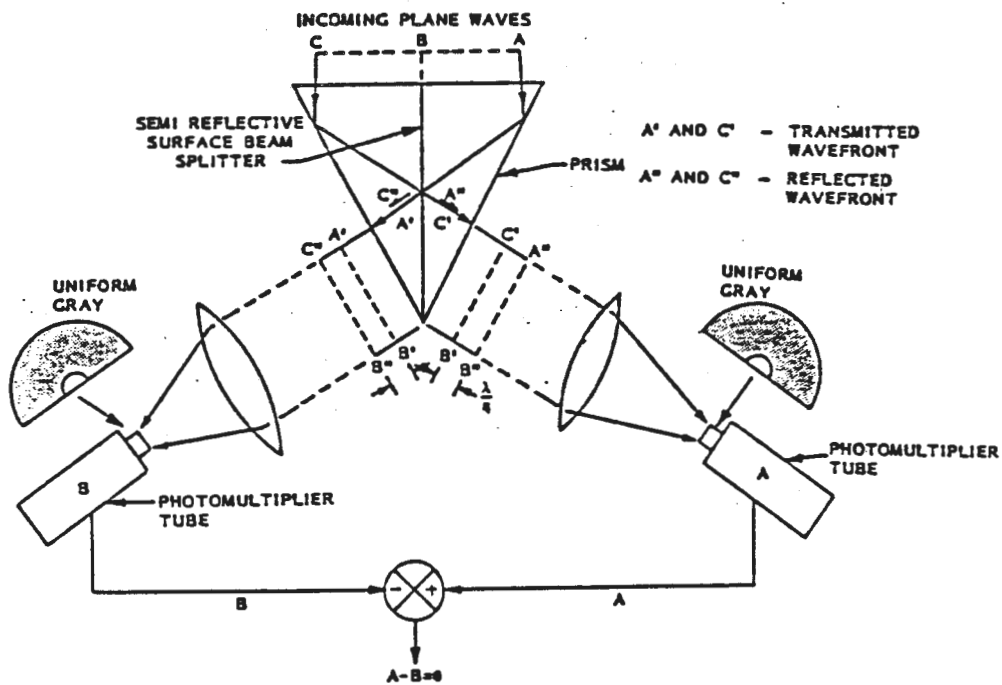

Figure 4-24 Koesters Interferometer Dead Center Tracking

Notice that the rays (C') and (A'') are 90 deg out of phase, and when combined will show up as a gray image on the PMT. The rays (A') and (C'') are also out of phase by the same amount, and when combined will show up as the same shade of gray image on the PMT.

If the incoming light wave is rotated by a small angle (e.g., 0.01 arcsec) as indicated in Figure 4-25, light ray (A) now enters the prism before the light ray (C) and its respective components will exit the prism earlier than before, while the light ray (C') and (C'') will exit later than in the previous case. Thus, the rays (A'') and (C') move further apart in phase, and when combined tend to interfere, causing the PMT image to be a darker shade of gray. On the other side of the prism, reinforcement occurs, causing a lighter shade of gray. The two PMT signals are then compared to determine the angle of the incoming light plane. A doublet lens and a mask are placed between the Koesters prism and the PMTs to focus the light and define precisely the 5 by 5 arcsec square instantaneous FOV.

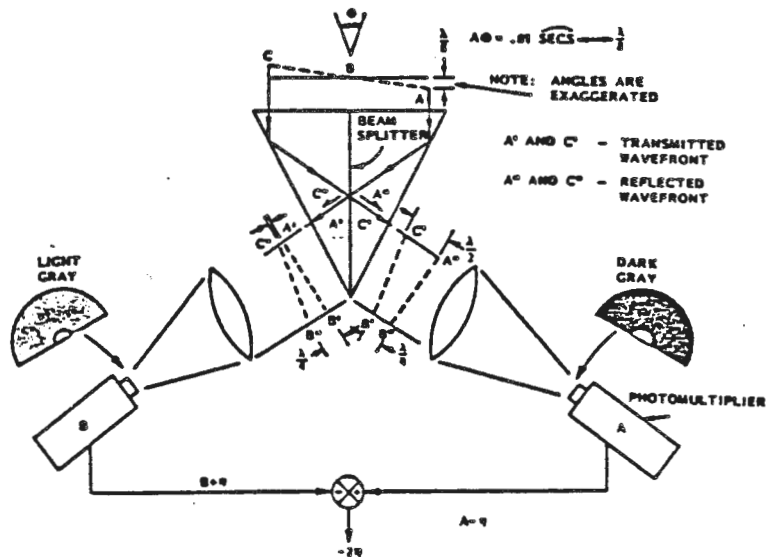

Figure 4-25 Koesters Interferometer Off-Axis Case

The FGE contains a microprocessor to handle feedback to the Star Selector Servo (SSS) motors. When the ST is star pointing, the FGS signal is fed back through a discrete proportional integral derivative control loop to the SSS, and the star selectors then track apparent motion of the star. The position of the star selectors is used by the PCS for fine pointing, together with the fine error signal that is performed by the PCS from the PMT counts.

4.5 OTA Equipment Section (OTA ES)

The OTA ES (Figure 4-26) has a 150-deg toroidal structural assembly containing nine bays forward of STA 299. The majority of the OTA electronic components are mounted in seven of these nine available equipment bays with access provisions through latched doors for Orbital Replaceable Unit (ORU) maintenance. The OTA ES conforms to LMSC Drawing 4171997.

The Electrical Power/Thermal Control Electronics (EP/TCE) and the Data Handling Interface Unit (DIU) are located in the OTA ES cavity. The Actuator Control Electronics (ACE) and Optical Control Electronics are located on the OTA ES doors.

4.5.1 Electrical Power Thermal Control Electronics (EPTCE)

The Electrical Power Subsystem (EPS) is the OTA power distribution network consisting of power switches, Electromagnetic Interference (EMI) filters, in-rush current control circuitry and circuit protection devices. The central power distribution and control box for the OTA is located in the OTA ES and is on-orbit replaceable.

The OTA controls temperatures in two ways; passively, or via local thermostatic controllers. Selection of the type of control employed is a function of the thermal requirements established for the various portions of the OTA, and is inherent in the design. The temperature of the primary and secondary mirrors, the focal plane structure and the main ring attachment points are all actively temperature controlled. The metering truss, which separates the primary and secondary mirrors, is passively controlled.

4.5.2 Data Interface Unit (DIU)

The OTA interfaces with SSM through the DIU box for all commands and telemetry. The DIU, in turn, interfaces with Data input Modules (DIMs) located in each OTA electronics box. The OTA receives three types of commands; high level discrete commands which directly actuate relays, low level discrete commands which interface with single bit logic receivers, and serial digital commands which are variable multibit commands used to input engineering values. The OTA command listing is described in OTA DR DM-01.

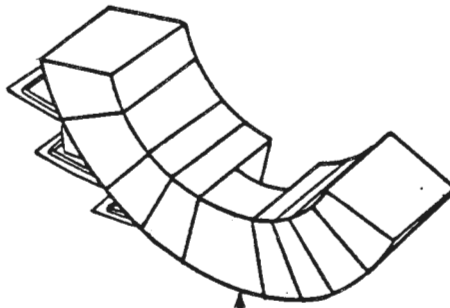

OTA EQUIPMENT SECTION

OPTICAL TELESCOPE ASSEMBLY EQUIPMENT SECTION

- DATA INTERFACE, THERMAL CONTROL, FINE GUIDANCE, POWER DISTRIBUTION

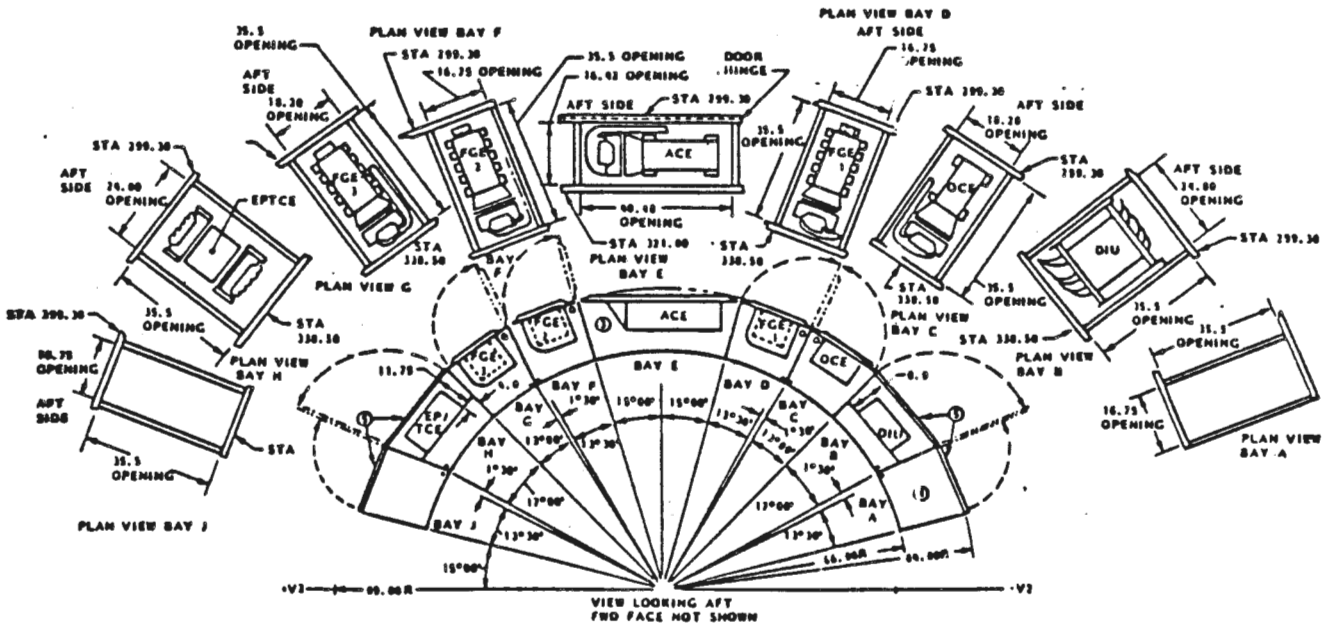

Figure 4-26 OTA Equipment Section

4.5.3 Actuator Control Electronics (ACE)

The ACE is an electronic box that controls the secondary and primary mirror actuators. The ACE accepts input data from the DIU and generates appropriate output drive signals for 30 actuator position assemblies. The actual positions are conditioned and telemetered to ground. The ACE contains primary and redundant dc/dc converters which provide isolated power for the data receivers.

4.5.4 Optical Control Electronics (OCE)

The OCE box selects, based on ground command, which interferometer to energize and serves all of the input, output and control functions for the Optical Control Subsystem (OCS).

4.5.5 Actuators

The actuators are stepper motor devices actuated from ground command. Each actuator contains a coarse full range diagnostic and an impulse detector capable of discerning a single step change. All actuators are designed so there are no overtravel constraints.

The secondary mirror position is adjustable in orbit for tip, tilt, decenter, and despace. The primary mirror contains push-pull actuators to correct the shape of the primary mirror surface in orbit. The system of actuators is controlled from the STOCC based on an analysis of the OCS data.

4.5.6 Fine Guidance Electronics (FGE)

The FGE contains the necessary electronics and firmware to provide fine pointing control signals to the FGS of the PCS. There are three FGEs on OTA, one for each of three FGSs required for pointing control and a secondary objective, Astrometry. Each FGE receives commands from the DIU to: generate rate commands and accept encoder position data from the Star Selector Servo unit (SSS), send commands to and receive data from the filter wheel assembly position, and send control signals and receive Photomultiplier Tube (PMT) count data from the interferometer. These data are processed by the FGE and transmitted to the SSM via the DIU. The FGE box is an in-orbit replaceable unit.

5.0 SCIENTIFIC INSTRUMENTS (SIs)

A group of five powerful and versatile SIs will be used to conduct the initial observations from the ST observatory. The first complement of SIs is composed of two cameras, two spectrographs and a photometer. The location of these SIs are illustrated in Figure 5-1.

AXIAL INSTRUMENTS (4)

- HIGH RESOLUTION SPECTROGRAPH
- FAINT OBJECT SPECTROGRAPH
- FAINT OBJECT CAMERA
- HIGH SPEED PHOTOMETER

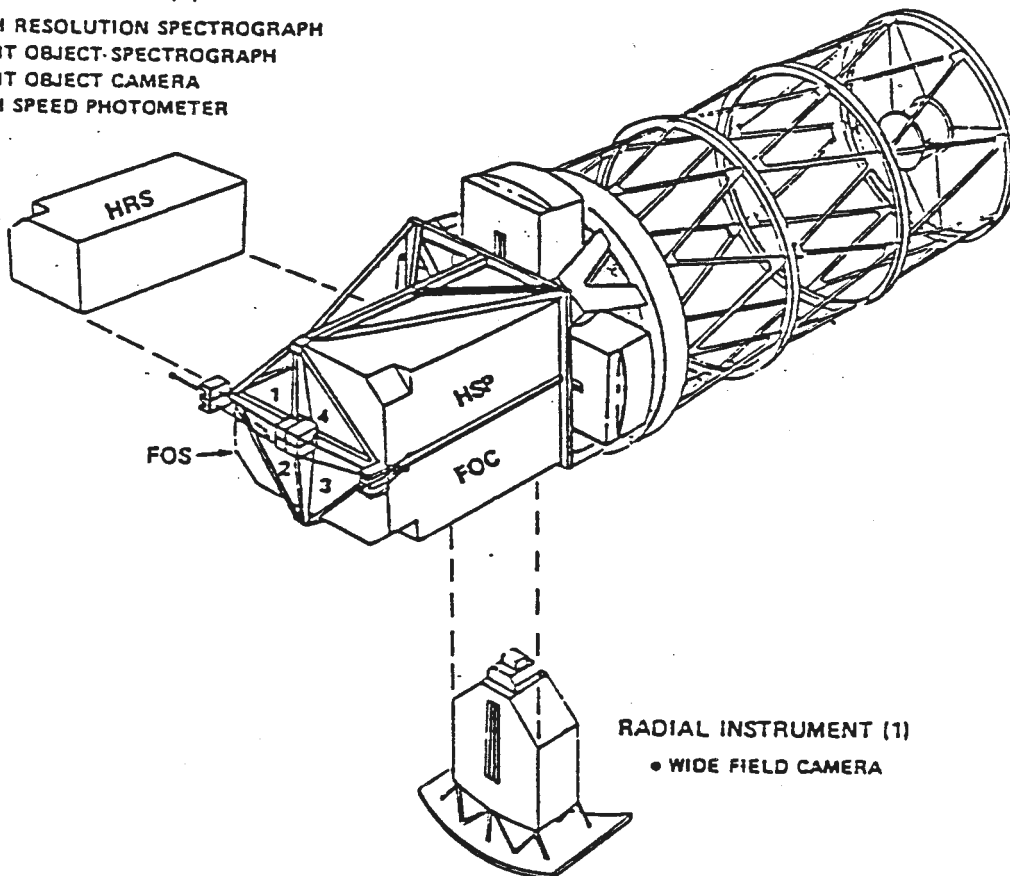

Figure 5-1 Location of Scientific Instruments

The Optical Telescope Assembly (OTA) houses three Fine Guidance Sensors (FGSs) that play the dual role of guiding the ST and performing as the Astrometry SI. The Fine Guidance Sensor (FGS) when used for an Astrometry SI is sometimes referred to as the sixth SI. Since only two of the three FGSs are required for the Pointing Control Subsystem (PCS), see Section 3.4.1.1, the third unit can be used for astrometric observations. The position of a target within the Field-Of-View (FOV) of this third FGS is determined by the encoder readings on the optical axis to within 0.001 arcsec, but mechanical, thermal, and other considerations may limit the obtainable accuracy to 0.002 arcsec.

The two "ST cameras" are the Wide Field/Planetary Camera (WF/PC) and the Faint Object Camera (FOC). The WF/PC is the only radial SI instrument and is located on the -V3 side of the Support System Module (SSM), and has access to the central portion of the focal plane through the use of a pickoff mirror. The WF/PC produces high quality, high resolution pictures over very wide spectral and dynamic ranges. The FOC is an axial SI located in one of the four Focal Plane Structure bays illustrated above and produces images in the visible and ultraviolet spectral regions. The FOC's image photon counting system makes the instrument very suitable for observing very faint, background-limited objects. The FOC has a FOV roughly one-third that of the WF/PC, although both cameras have operationally variable FOVs.

The two "ST spectrographs" are the Faint Object Spectrograph (FOS) and the High Resolution Spectrograph (HRS). The FOS utilizes extremely small FOVs, and this, combined with the very faint objects which are normally viewed, means that the FOS will probably pose the most difficult target acquisition problem among all the SIs. The HRS is used in the ultraviolet only and few visual object references are available since many of the targets to be observed with this SI are of unknown magnitude in the ultraviolet. A good guess of the scale of visual magnitude to which the HRS objects correspond is probably 0 to 18 m apparent visual magnitude (Mv).

The single "ST photometer" is the High Speed Photometer (HSP) and consists of a set of image-dissector tubes, each with a set of filter/aperture combinations in front of their photocathodes and a photomultiplier tube. The Space Telescope is reoriented, albeit slightly, each time the energy from a particular object is required to go through a different filter/aperture combination.

Figure 5-2 shows the spectral ranges of these SIs in comparison with the spectral range of the OTA.

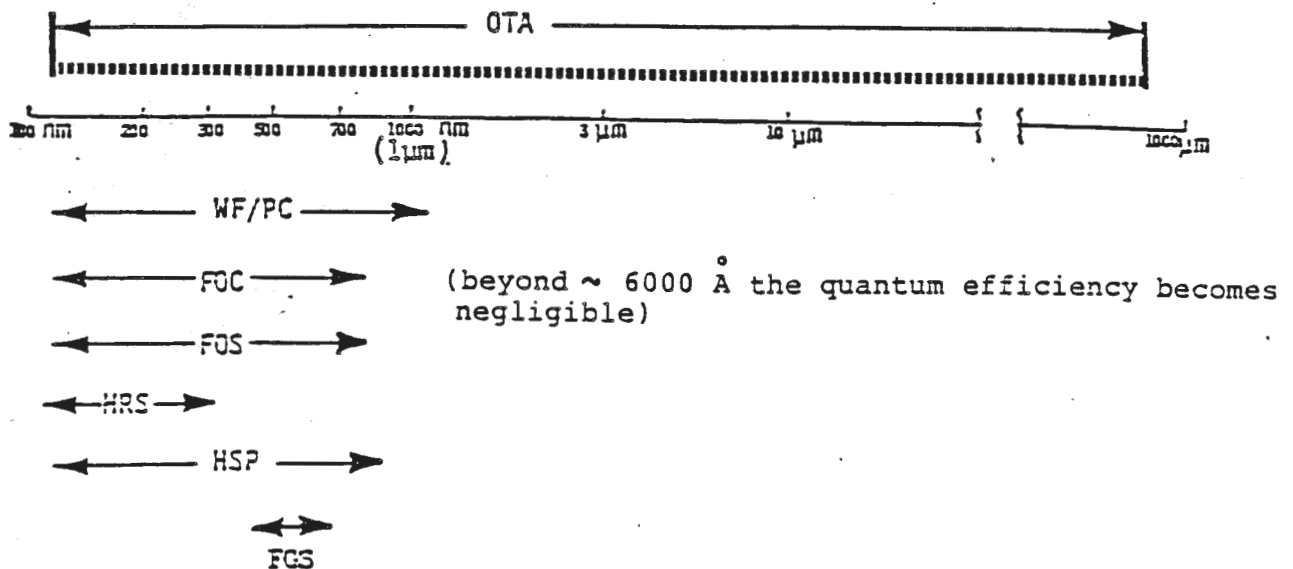

Figure 5-2 Spectral Ranges of the SIs and the OTA

The entrance apertures of all of the instruments are effectively located in the focal plane of the telescope which has a scale of 3.58 arcsec/mm. The four axial bay configurations are modular and can be theoretically exchanged one for the other. The typical weight of an axial bay instrument is about 700 lb with dimensions of 0.9 by 0.9 by 2.2 m; the WF/PC is somewhat smaller and lighter. All instruments will draw in the order of 110 to 170 W during observations. The SIs are designed so that removal of the existing SI or installation of a new instrument can be achieved in-orbit by a suited astronaut operating from the Orbiter.

Described below are the expected basic performance characteristics of all six of the science instruments. The cited characteristics are, in most cases (see references to Tables 5-1 through 5-6), minimum performance characteristics specified in the current contracts for the hardware of the SIs. The performance characteristics will be further evaluated during orbital operations.

The four axial bay instruments are designed to count individual photons with the HSP also measuring flux. Thus the limiting magnitudes and signal-to-noise (S/N) ratios given below and in the tables of performance characteristics can be scaled using the "most-optimistic" formulae: magnitude (m) proportional to $2.5 \log(\text{time})$ and S/N proportional to $(\text{time})^{**\frac{1}{2}}$. These relations are based only on Poisson statistics and they neglect, among other things, background noise from the detector, sky background, and radiation effects, but are probably adequate for rough estimates of what may be feasible. The above scaling relations can be used for crude estimates of the sensitivity as a function of time of the WF/PC although readout noise and radiation effects will limit the usefulness of combining exposures for this instrument.

The atmospheric absorption of electromagnetic radiation limits ground-based optical astronomy primarily to the narrow spectral band corresponding to visible light. Radiation in the flanking ultraviolet and infrared regions is almost totally blocked. The upper edge of the gray areas indicates the boundary where the intensity of the radiation at each wavelength is reduced to half its original value, as shown in Figure 5-3. The SIs and OTA spectral ranges are also shown in Figure 5-2.

The absence of atmospheric turbulence, and absorption in the ultraviolet and infrared spectral bands will permit the observation of a greatly increased volume of space. Also possible are studies of nearby objects with finer angular and temporal resolution, higher photometric accuracy, and broader spectral coverage than has been possible heretofore.

The following sections on the WF/PC, FOC, FOS, HRS, HSP and the FGS used for astrometric observations are briefly described. Reference should be made to the SI notebooks for detailed information regarding the SIs design and performance characteristics.

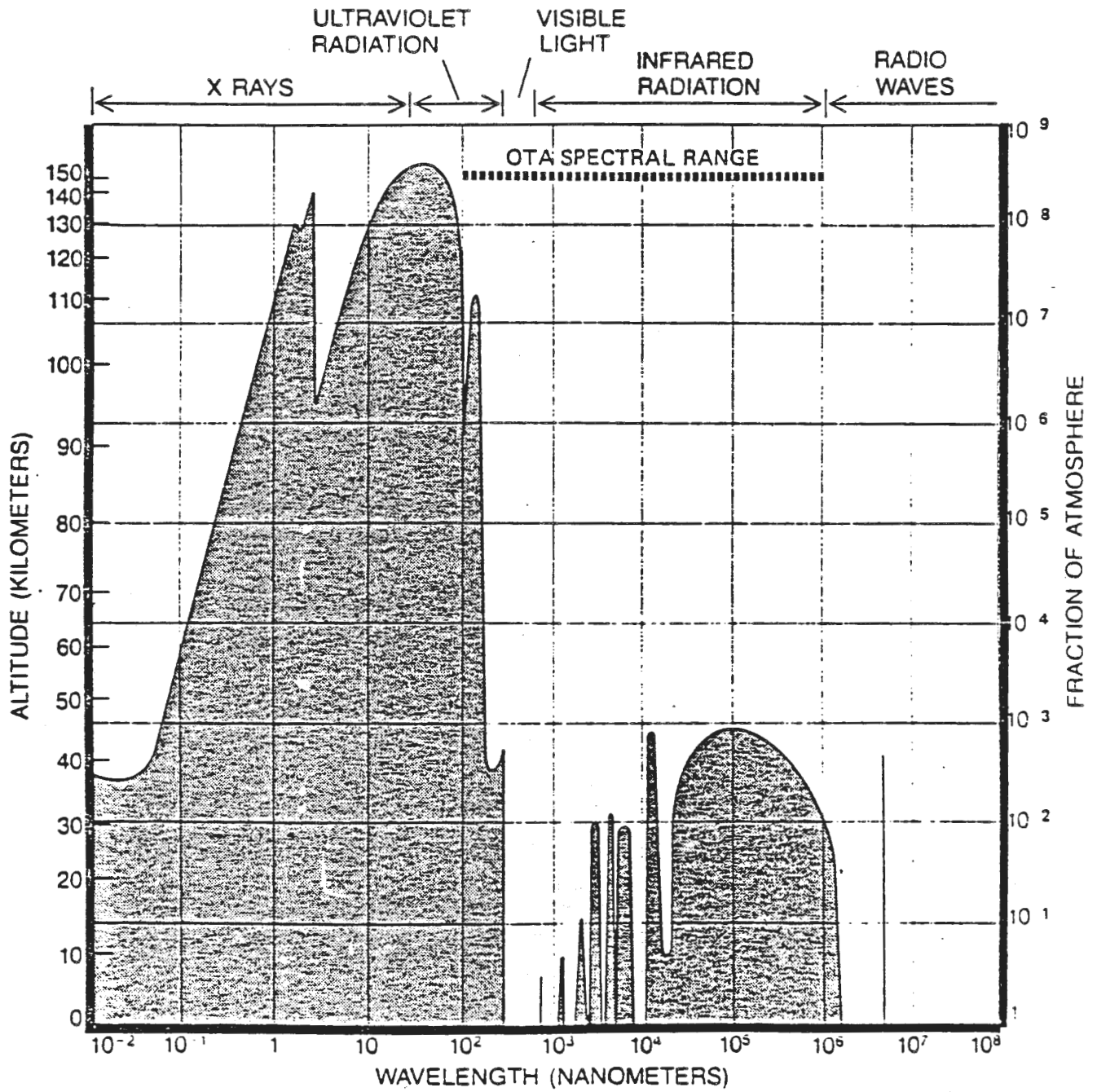

Figure 5-3 Atmospheric Absorption Spectral Range

5.1 Wide Field/Planetary Camera (WF/PC)

The WF/PC (Figure 5-3) is capable of operation with a wide field focal ratio of $f/12.9$, as well as a planetary ratio of $f/30$. The resolution of this instrument will surpass that of ground-based resolution by a factor of at least 10.

The WF/PC is designed with a complex grouping of instrumentation and mirrors. Its FOV is split by a pyramidal mirror into four separate sections that are focused onto four charge-coupled devices. These devices have been designed to receive low light intensities at very high resolution. Part of the image is received on each CCD where it is subdivided into 640,000 picture elements. Light intensities of each picture element are sent to earth by means of telemetry signals for assembly into images.

The WF/PC will be used to gather data relating to cosmic distance scales; cosmic evolution; the comparison of near and far galaxies; stellar population studies; the distribution of energy in stars and compact objects; observations of stars in formation and supernova; planetary atmosphere observations and comparisons; searches for planets around nearby stars; and comets.

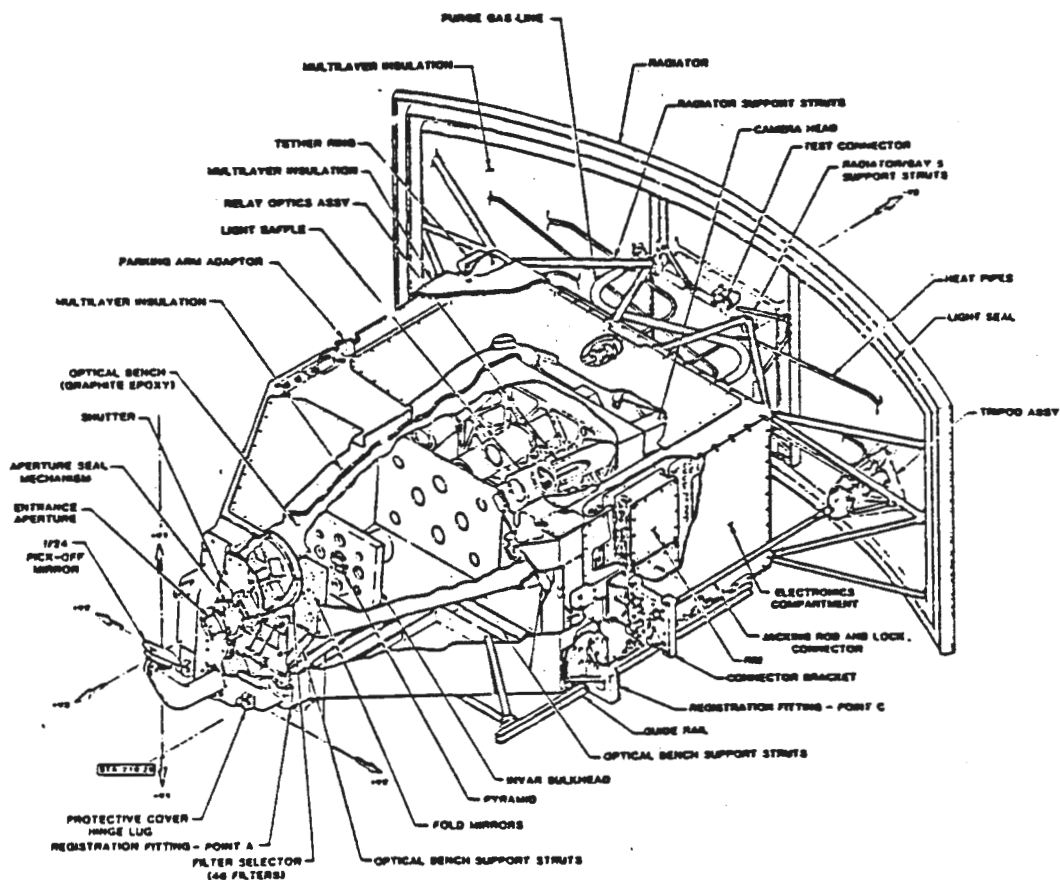

Figure 5-4 Wide Field/Planetary Camera

The WF/PC can be operated in two modes that are characterized loosely by the two names: Wide Field Camera (WFC) and Planetary Camera (PC). The WFC mode will be used primarily for deep sky surveys (field: 2.7×2.7 arcmin²). The PC mode will provide higher spatial resolution capabilities over a smaller field of view (1.2×1.2 arcmin²) than the WFC. Both cameras will be used to photograph astronomical scenes which include both faint and bright sources with their wide dynamic range. The basic performance characteristics in both these modes are given in Table 5-1.

The WF/PC is unique among the ST SIs in several ways. It is located in a radial bay; light is transferred into the instrument by means of a pickoff mirror centered on the optical axis of the OTA. An external thermal radiator, which is part of the exterior surface of the ST, is used for cooling. The wavelength range is larger than for any of the other instruments; the red response is particularly crucial for many scientific problems. The quantity of data (bits per year) generated by the WF/PC in the primary and parallel modes is expected to exceed that of the other instruments.

In both the WFC and PC modes, the detectors are four (800x800) charge-coupled devices (CCDs). The incoming light can be directed onto either the four WFC CCDs or the four PC CCDs by means of a pyramidal mirror that can be rotated about its apex. The WF/PC contains two complete optical relay and detector systems, each capable of producing a four-part image mosaic. The center-to-center pixel separation is 15 μ m. The CCDs are cooled to $-95^\circ \pm 0.5^\circ\text{C}$ in order to reduce the amount of dark current accumulated during exposures. The wide wavelength coverage is possible because the CCDs are coated with an organic phosphor, coronene, which converts ultraviolet photons into visible photons; the intrinsic long wavelength response of the CCDs is very good. The optical performance in the visible band of the WF/PC is approximately equivalent to that of an optical system with a total wavefront error of $\lambda/10$. Because of a slight overlap between the edges of the different 800x800 arrays, it is possible to form one larger picture without any significant loss of data.

The WF/PC provides a sensitive and highly linear detector over a broad wavelength region (1,150 Å to 1.1 μ m) and a wide dynamic range (8 m to 28 m in the visual band). The minimum exposure time is 0.1 sec (determined by the speed with which the shutter can be opened and closed). The typical long exposure is in the order of 3,000 sec (corresponding to one-half an orbital period). A read-out noise of about 15 electrons RMS per pixel, and radiation effects, limit the advantage of stacking different exposures (the OTA plus WF/PC optical throughput is ~ 0.20 at 5500 Å).

Note that planets, because they are not point sources, are observable with short observing times in the planetary mode even though their integrated brightnesses exceed the 7.5 magnitude limit. The full throughput quantum efficiency of the flight WF/PC is expected to exceed the following requirements: 3 percent from 1200 Å to 3000 Å; and 8 percent from 7000 Å to 1 μm. The above data allow the computation of rough performance characteristics for intermediate exposure times and for a variety of wavelengths. Absolute photo-metric calibration is achieved primarily by observation of standard stars; flat-field calibrations are made using the earth or limb of the earth.

A number of important scientific applications of WF/PC are: determination of H₀; tests of cosmological models; comparative studies of distant and faint galaxies; stellar population studies to faint magnitudes; high resolution luminosity profiles of galactic nuclei; energy distributions of stars and compact galactic and extragalactic objects; dynamic motions in supernova remnants and proto-stars; search for extra-solar planets; synoptic studies of planetary atmospheres; and high resolution and UV studies of comets.

 | This instrument can operate at two different focal ratios: |
 | f/12.9 or f/30. In the first mode, the instrument is |
 | referred to as the Wide Field Camera (WFC) and in the second |
 | Mode, as the Planetary Camera (PC). Pictures can be taken, |
 | in either mode, with any one of a wide variety of speccral |
 | filters or transmission gratings. |
 |-----

| Characteristics | WFC | PC |
|---------------------------------------|----------------------------|-----------------------------|
| Field of View | (2.67 arcmin) ² | (1.15 arcmin) ² |
| Angular Resolution (1 pixel) | (0.1 arcsec) ² | (0.043 arcsec) ² |
| Bandwidth (quantum efficiency >1%) | 1.15xE3 Å to 1.1 μm | 1.1xE3 Å to 1.1 μm |
| Photometric Accuracy | ~ 1% | ~ 1% |
| Dynamic Range (S/N>3) | 9.5 m < Mv < 28 m | 8.5m < Mv < 28 m |

Table 5-1 Wide Field/Planetary Camera Performance*

*References: (1). J. A. Westphal et al. (1977), Technical Proposal - Instrument Definition Team, WF/PC for ST, submitted by the California Institute of Technology to NASA; (2). J. A. Westphal et al. (1979), WF/PC GSFC Preliminary Design Review Package (CM-04). Table Revised by D. Rodgers/JPL 10/23/84.

5.2 Faint Object Camera (FOC)

The FOC (Figure 5-4) captures images of very faint objects in the universe and possesses the capability of detecting stars as faint as the 28th magnitude. A large ground observatory can do no better than pick out stars of magnitude 24; this task will be easily accomplished by the FOC (the lower the number of magnitude, the brighter the object).

This instrument gathers and focuses incoming feeble starlight on an electronic image intensifier, the output of which is scanned by a EBS camera tube. An FOC image contains up to 525,000 picture elements.

The FOC has an F/48 focal ratio camera system which can be also operated in a spectrographic mode, needed to study the structure and dynamics of the center regions of galaxies. Fourteen insertable filters are supplied for this mode of operation. In addition, this instrument has a basic focal ratio of f/96. For this mode of operation four filter wheels are provided, each containing a variety of filters with 12 positions that can be inserted in the optical path.

This instrument will be used to perform detailed studies on shock fronts and condensing gas clouds; investigate variable brightness stars; establish stellar masses; study extragalactic supergiant stars; collect data on globular clusters; and investigate the theory that quasars might be at the center of faint galaxies.

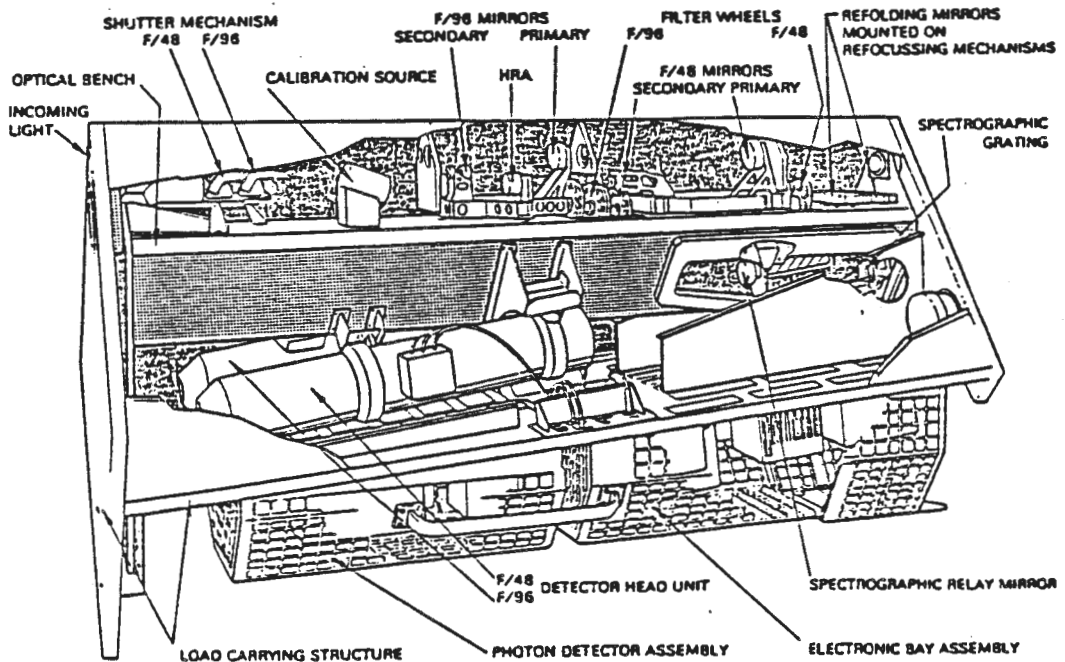

Figure 5-5 Faint Object Camera

The primary purpose of the FOC is to utilize the full optical performance of the ST, reaching the faintest limiting magnitudes and highest angular resolution possible. The basic performance characteristics of the FOC are summarized in Table 5-2.

The FOC is complementary to the WF/PC. The FOC provides a higher spatial resolution and the WF/PC a larger FOV. The FOC is faster than the WF/PC in the wavelength range between 1,200 Å to 4,000 Å if the actual noise levels for both cameras are consistent with current expectations. The two systems are about equal in speed at 5,000 Å. As one goes farther into the red, the WF/PC is increasingly more advantageous, being faster than the FOC by a factor > 10 for $\lambda > 6,000$ Å.

The FOC contains two independent camera systems, one operating at f/96 and one at f/48. The f/96 relay slightly oversamples the expected point spread function of the OTA at 6,328 Å; the focal plane image is magnified by a factor of four in order to minimize the resolution loss resulting from detector spatial sampling. The pixel size is 25 μm which corresponds to 0.022 arcsecs at f/96. The f/48 system magnifies by a factor of two in order to include a wide field with only moderate resolution loss due to detector sampling (at f/48 the fixed size corresponds to 0.044 arcsec).

The f/96 mode contains a coronagraphic facility which allows the camera to suppress light from bright objects while observing faint sources in the nearby field. When centered on a stellar image, the occulting figure (0.4 arcsec width and 0.8 arcsec thickness on the sky) reduce the total measured flux from the image by a factor of approximately 20. It is estimated that imaging of a faint object near (one arcsec) a bright object will be possible for a difference in magnitudes as large as $\Delta M_v = 16.7$ m.

The f/96 mode contains also a f/288 capability. A compact Cassegrain assembly which produces a magnification of three can be inserted in the f/96 optical path, giving a pixel size of 0.007 arcsec.

The f/48 system provides a long-slit (up to 20×0.1 arcsec²) spectrographic capability for observing extended objects. A fixed grating can be used to disperse the light and provide first, second, and third and fourth images covering the wavelength ranges 3,600 Å to 5,400 Å, 1,800 Å to 2,700 Å, 1,200 Å to 1,800 Å and 900 Å to 1,350 Å, respectively. This spectrographic mode complements the FOS and HRS. The spectral resolution is 2×10^3 (a factor of 10 less than for the HRS) and comparable to that of the FOS. However, the FOC spectrographic mode is unique in that it makes possible spectroscopic profiles of extended objects with an angular resolution of order 0.1 arcsec. This option is useful in, for example, measuring velocity dispersions as well as temperature, density, and composition distributions in galaxies, comets and nebulae.

Independent sets of special purpose filters are provided for the f/96 and f/48 modes. The f/96 mode has four filter wheels, each

containing 12 positions (comprising 34 filters), that can be inserted in the optical path. The filter wheels contain a variety of filters, including five neutral density filters ($\Delta m = 1, 2, 4, 6, 8$), two objective prisms [$\lambda/(\Delta \lambda) = 50$ at 1,500 Å and $\lambda/(\Delta \lambda) = 100$ at 2500 Å], three polarizers for measuring linear polarization (0, 60, 120 deg), and a number of special purpose filters. By suitably combining the neutral density filters a maximum attenuation of $\Delta m = 9$ can be achieved. The f/48 mode has 14 insertable elements including the two objective prisms described above, and 12 band-pass filters.

The identical detectors for the two f-ratios count individual photons; the conceptual design is similar to the imaging photon detectors developed by A. Bokserberg. The first stage of each detector is an EMI-developed three stage, magnetically focused, image intensifier tube having a gain of approximately 10^{*5} . The first-stage photocathodes are "hot bialkalis" on Mg F2, which have useful sensitivity over the wavelength range 1,150 Å to 7,000 Å. The thermionic dark currents of the photocathodes are expected to be very low at ambient temperatures, of order 10^{*-4} counts/pixel/sec. The camera tube that scans the output of the intensifier is a high-gain Westinghouse (WX 32 719) TV tube, which is a high sensitivity, high resolution, electrostatically focused-image-section EBS/SIT tube.

The basic limitation on the field size at highest resolution is determined by the amount of data that can be stored with a limited but dedicated memory. The memory limitation corresponds, with 16-bit words, to a total number of pixels that can be scanned of 512x512 or equivalent combinations. Each detector consists of 1024x1024 pixels. A variety of imaging formats are available currently: 1024x512 (with an 8-bit address), 1024x256, 512x512, 256x256, 128x128, and 64x64 format corresponds to 11.3 x 11.3 arcsec², a larger field, 22.5 x 11.3 arcsec² can be obtained also at f/96. The largest field available for the f/48 mode is 44x44 arcsec², obtained in the 1024x512 8-bit zoom format.

The limiting magnitudes given in Table 5-2 for the brightest objects that can be observed are determined also by the TV scan rate. If the count rate becomes too high, the detector response is significantly nonlinear. Brighter objects than those listed in Table 5-2 can be observed with the aid of attenuating filters or by using small-scan formats. The faint limiting magnitudes in the ultraviolet may be one or two magnitudes fainter than the faint visual magnitude limits shown in Table 5-2. A cumulative exposure of 10 hours should lead to a signal-to-noise ratio of at least four for stellar objects as faint as $M_v = 28$ m.

The possible applications of the FOC are very numerous and include observations of RR Lyrae stars, Cepheids, bright supergiants, globular clusters and giant H II regions as distance indicators out to expansion velocities $> 10^{*4}$ km sec⁻¹; investigation of time dependent features on planetary surfaces; to establish stellar masses; detailed studies of shock fronts, condensing gas clouds and the relationship of young stars to the

gas around them in regions of star formation, optical identification of faint radio and X-ray sources; and the search for direct evidence that quasars and BL Lac objects are the brightest nuclei of faint galaxies.

| <p>The Faint Object Camera consists of two independent camera systems that operate, respectively, at f/96 and f/48. The f/96 system contains a coronagraphic facility that can be used to mask the light from bright objects. The f/48 system also provides for long slit (20 x 0.1 arcsec²) spectroscopy with a fixed grating.</p> | | |
|--|--|--|
| Characteristic | f/96 | f/48 |
| Field-of-View | 11 x 11 arcsec ² 22 x 22 arcsec ² slightly degraded resolution | 22 x 22 arcsec ² 44 x 44 arcsec ² slightly degraded resolution |
| Pixel Size (arcsec) ² | 0.022 x 0.022 | 0.045 x 0.045 |
| Wavelength Range (quantum eff. >1%) | 1,200 A - 6,000 A | 1,200 A - 6,000 A |
| Dynamic range (**) | point sources: 21m < Mv < 28 Mv extended sources: 15 Mv/arcsec ² to 22 Mv/arcsec ² | point sources: 21m < Mv < 28 Mv extended sources: 15 Mv/arcsec ² to 22 Mv/arcsec ² |
| Photometric Accuracy (when not photo-noise limited) | at least 2% | at least 2% |

Table 5-2 Faint Object Camera Performance*

**Cumulative 10 hour observations without attenuating filters or combining pixels; S/N = 4.

* References: (1). F. Macchetto and R. J. Laurance, (1977), The Faint Object Camera, ESA SN-126; (2). J. J. Brahm, FOC Scientific and Technical Status Report, ST Science and Operations Project, internal GSFC report - Feb. 12, 1979; (3) F. Macchetto (1979, "Status of the ST Project in Europe," in ESA/ESO workshop on the Space Telescope, ed. F. Macchetto, F. Pacine, and M. Tareghi.

The Camera Module is subdivided into the Optical Bench, the load carrying structure, and the Electronic Bay Assembly and are reviewed in the following sections.

5.2.1 Optical Bench

The optical relay elements (mirrors, filters, prisms, polarizers, and grating), Detector Head Units (DHUs), mechanisms, and the on-board calibration unit as mounted, has to fulfill a very high level of requirements in terms of long and short term stability, supported.

5.2.2 Load Carrying Structure Assembly

This assembly performs the function of mechanical support for the optical bench, the thermal control, the electronics and the harness. Moreover, the structure provides all mechanical interfaces to the Space Telescope.

5.2.3 Electronic Bay Assembly (EBA)

The EBA with its various electronic units, mounted on the EBA platform, can be grouped into the following:

- a. The Remote Terminal Unit (RTU) and the Data Handling Interface and Control Unit (DICU) provide the data links between the SI C&DH of the ST and the Camera Module as well as the Photon Detector Assembly (PDA).
- b. The On-Board Computer for the interpretation of macrocommands and generation of command sequences control the FOC modes.
- c. The Scientific Data Store (SDS) process and store the image data gathered by the PDA during an exposure, and other support electronics, comprised of the Power Control Unit, the Thermal Control Electronics (TCE) and the Mechanism Drive Electronics for performing power conditioning, control and switching of actuators such as electromagnets and torque and stepper motors, as well as temperature control of the FOC.

The Photon Detector Assembly (PDA) consists of two Detector Head Units (DHU) of identical design and the associated electronics. The detector design uses a three stage intensifier, which is magnetically focused by a permanent magnet. The output of the intensifier forms a visible image in a phosphor. In this way, even UV images, after passing through filters, are converted to visible light.

A lens system reimages this output on a television camera tube, which then "reads" the images. The detector operates in a photon counting mode where every photon detected by the photocathode is recognized as a single photon event whose position of arrival is stored as an X-Y coordinate in a dedicated memory, the SDS. Basically the detector is capable of obtaining an image of 1024 X 1024 pixels. However, the requirement to store the image at a high speed of 10 MHz, limits due to power and mass, restrains the storage capacity to 4 megabits. With a 16 bit word, this corresponds to a total number of 512X512 pixels, but with an eight bit word, a total number of 1024X512 pixels can be selected within the 1024X1024 useful area of the detector in 1/4 pixel increments both horizontally and vertically. However, the monitoring is limited to 32 pixel increments. Another useful characteristic of the detector is that the size of the pixel can be changed from 25X25 μm to 50X25 μm thus allowing a larger FOV to be scanned, albeit at a lower resolution.

The PDA can be subdivided into the following main parts:

- a. Two Detector Head Units, each comprised of:
 - (1) Intensifier section
 - (2) Camera section
 - (3) Preamplifier
 - (4) EHT cables
 - (5) Mounting feet.
- b. PDA Electronic Units mounted on the PDA platform, comprised of:
 - (1) One Power Conditioning Unit which takes the supply voltage from the AC bus of the FOC-CM and provides all voltages required by the PDA.
 - (2) Two Camera Electronic Units (CEUs) which provide the necessary drives and operating potentials to the camera tubes.
 - (3) Two Video Processing Units (VPUs) which are comprised of the electronics to implement the operational modes of the detectors.
 - (4) Two Intensifier Electrical High Tension (IEHT) boxes which provide 36 KV (nominal) for the intensifier section of the DHUs.
 - (5) Two Camera Electrical High Tension (CEHT) boxes which provide 12 kV (nominal) for the camera section of the DHUs.

Camera Module and PDA harnesses are designed to provide the connection between the various subassemblies.

5.3 High Resolution Spectrograph (HRS)

The HRS (Figure 5-5) is the only ST instrument that is devoted wholly to studies in ultraviolet light. It is equipped with detectors that are deliberately designed to be insensitive to visible light, to facilitate studies of faint ultraviolet emissions from stars that often have much brighter visible emissions. The HRS will make observations with spectral resolving power as high as 100,000, corresponding to the observation of wavelength details as fine as 12 thousandths of an Angstrom unit (\AA) at wavelength 1200 \AA . For observations of rapidly varying objects, the HRS can obtain spectra at intervals as closely spaced as 50 msec.

The HRS is the only ST instrument that does not contain a microprocessor; it is controlled by an onboard computer that also processes data from other instruments. Using programs stored in this computer, called the NSSC-1, the HRS will make efficient use of observing time.

When ground intervention is possible, astronomers using the HRS will be able to adjust the previously stored sequence of observation commands on the current target and maximize the scientific return from the observations based on clues in data just telemetered to the ground.

This instrument will be used to study such objects as supernova, active galaxies, bright quasars, and phenomena in the earth's own solar system. It will investigate the physical composition of exploding galaxies, quasars, and other dense objects; study the loss of mass of one star to another in binary systems; measure the total amount of matter expelled in stellar explosions; and explore the physical composition of gas clouds.

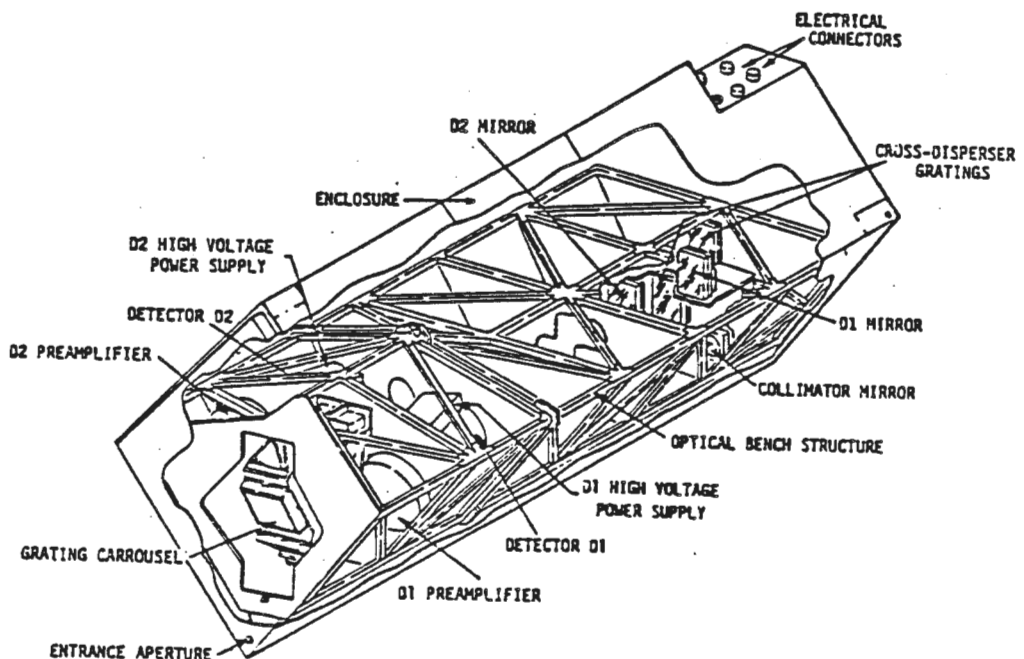

Figure 5-6 High Resolution Spectrograph

The HRS is a photon-counting, ultraviolet instrument that provides a resolving power equal to that of the largest ground-based Coudé spectrographs. It can perform moderate and high resolution spectroscopy in the region between 1,100 Å and 3,200 Å. The basic characteristics are shown in Table 5-3.

The HRS, provides three modes of varying spectral resolution. The primary HRS observing modes are with a resolving power $R = \lambda / (\Delta \lambda) = 1 \times 10^5$ (by far the highest on ST) and with $R = 2 \times 10^4$, both covering the wavelength 1050 Å to 3,200 Å. Most of the numerous scientific programs for HRS refer to these two primary modes. The moderate resolution mode has $R = 2,000$. However, this HRS moderate resolution mode is limited to the region 1050 Å to 1,700 Å. The moderate resolution of the HRS is used for efficient target acquisition, for estimating exposure times at higher resolution, and to provide valuable sensitivity in short wavelength region where the OTA efficiency is low and higher resolution spectroscopy is not feasible. The partial redundancy with the FOS is intentional.

Light from the OTA enters the HRS through one of two entrance slits which are selected by arranging slightly different orientations to the ST. The larger slit subtends about two arcsec² and is used for target acquisition operations, whereas the other slit is only about 0.25 arcsec² and is used for normal spectral data-taking operations.

The light passing through the slits falls on a collimator mirror which folds the beam onto one of the elements which can be selected on the carousel. The plane mirror passes undispersed light through the rest of the optics to form a direct image on one of the Digicon detectors. This arrangement is used for more rapid target acquisition on most targets.

The HRS, contains two independent Digicon detectors, each with 512 diodes. For one of the HRS Digicons, the photocathode/window combination is MgF₂/CsTe, while for the other it is LiF/CsI (peak efficiency at ~ 1,250 Å). Three of the gratings (blazed at 1,600 Å, 2,000 Å, and 2,700 Å) diffract the light towards a camera mirror which focuses a first-order, high resolution ($R = 2 \times 10^4$) spectrum on the Digicon having a MgF₂/CsTe combination. A fourth grating (blazed at 1,400 Å) combination, provides a similar spectrum on the Digicon with the LiF/CsI combination, using a second camera mirror. The moderate resolution ($R = 2 \times 10^3$) mode is also recorded in first order by this Digicon. The highest resolution observations ($R \sim 10^5$) is achieved with the aid of a sixth, echelle grating that can be used with either Digicon. A limited range of the spectrum is recorded by the array at one time. In the $R = 2 \times 10^4$ mode, the length of the spectrum on the detector varies from about 30 Å at 1,050 Å to approximately 45 Å at 3,200 Å. The spectrum length for the $R = 2,000$ mode is approximately 290 Å. In the echelle, high-resolution mode ($R = 10^5$) the spectrum length varies from 4.5 Å at $\lambda = 1,050$ Å to 16 Å at $\lambda = 3,200$ Å.

The sensitivity of the HRS in various wavelength ranges depends on the individual efficiencies of the grating and Digicons as finally manufactured by the HRS vendors. The sensitivity goals are: for the $R = 2 \times 10^4$ mode, a quantum efficiency in excess of 1 percent over the interval from 1,200 Å to 2,800 Å and a maximum of at least 3 percent within this spectral range; for the $R = 10^5$ mode, a spectrograph efficiency in excess of 0.4 percent at the blaze wavelength over the entire interval from 1,200 Å to 2,800 Å, and a maximum efficiency no less than 1.2 percent within the 1,800 Å to 2,800 Å range.

The brightness ratio of signals ($> 10^5$ total counts) from any two channels within the image format and within the Digicon dynamic range remains constant to within 1 percent (1 sigma) of the mean ratio value over periods up to 30 days. For count rates randomly distributed in time up to 10^5 counts/sec/channel, the measured rate is correctable to the true rate to an accuracy better than 4 percent. For count rates between 1 and 10^4 counts/sec/pixel, the measured rate is correctable to the true rate to an accuracy of better than 1 percent.

The HRS achieves a signal-to-noise ratio of at least 10 in each channel at a flux maximum near the wavelength of maximum HRS efficiency in a 1×10^3 sec integration period on an unreddened AOV stellar flux distribution corresponding to approximately $V = 14$ at $R = 2 \times 10^4$ and to approximately 11 at $R = 1 \times 10^5$. This assumes an OTA throughput of 0.6, a radiation background of 0.001 counts/channels/sec, and a sky background of 10^{-3} photons $\text{cm}^{-2} \text{sec}^{-1} \text{Å}^{-1} \text{arcmin}^{-2}$. At ambient temperature, the photocathode dark current is less than 0.01 counts/diode/sec.

The minimum integration period for a single frame of data is 50 msec when data are transmitted directly and 200 msec when data are stored on-board. The reset time, that is the time between successive integrations, is less than 2 msec.

Accurate calibration of wavelengths and system response is achieved by the use of two types of internal light sources; a Pt-Ne lamp for calibrating the wavelength scale (accurate to 0.40 pixels, 1-sigma), and two lamps that provide "flat-field" illumination of the Digicons.

Important observations that are to be made with the HRS are: studies of the very local gas, of dense clouds, and of previously undetected molecules all in the interstellar medium; studies of mass loss, mass transfer, and coronal winds in stars using OB supergiants in the Magellanic clouds, red giants in the galaxy, close X-ray binaries, and late-type stars; a spectroscopic investigation of the nuclei of Seyfert galaxies and a detailed study of the UV spectrum of 3C 273; a study of the structure of the atmospheres of the Jovian planets, of auroral activity on other planets and satellites.

The HRS can perform high ($R=10^{**5}$ and $R=2 \times 10^{**4}$) and moderate ($R=1000$) resolution spectroscopy in the ultraviolet, as well as time-resolved spectroscopy. Two photon-counting Digicon detectors are provided, one with a LiF/CsI and one with a MgF2/CsTe window/photocathode combination.

| Characteristics | Expected Performance |
|--|---|
| Spectral Resolving Power | $R = 1 \times 10^{**5}, 2 \times 10^{**4}, 1 \times 10^3$ |
| Entrance Apertures | 0.25 x 0.25 arcsec ² 2.00 x 2.00 arcsec ² |
| Wavelength Range (HRS Efficiency: 0.4% to 4.0% preliminary estimate) | (1.1 to 3.2) x 10 ³ Å ($R=10^{**5}$) (1.1 to 3.2) x 10 ³ Å ($R=2 \times 10^{**4}$) (1.1 to 1.7) x 10 ³ Å ($R=1 \times 10^3$) |
| Limiting Magnitude ($2 \times 10^{**3}$ sec; AOV star near peak HRS efficiency; S/N > 10) | Mv = 11 m ($R=10^{**5}$) Mv = 14 m ($R=2 \times 10^{**4}$) Mv = 17 m ($R=1 \times 10^3$) |
| Photometric Accuracy (count rate < 10^{**4} /sec/pixel) | ~ 1% |
| Minimum Exposure Time (reset time < 0.002 sec) | 0.050 sec - Direct Downlink 0.200 sec - Flight Software |

Table 5-3 High Resolution Spectrograph Performance*

*References: (1) J. C. Brandt et al. (1977), A HRS for the ST, Technical Proposal-Instrument Definition Team, submitted by GSFC to NASA Headquarters, HRS-680-77-01; (2) J. C. Brandt et al. (1979), Proceeding Society of Photo-Optical Instrumentation Engineers, Vol. 172, in the press.

Table revised by W. Meyer, H. TePoel, J. Kinsey/BASD 10/16/84.

For more detailed information reference -
SI System Description and Users Handbook for the High Resolution Spectrograph (HRS) for the Space Telescope (ST), HRS-2176-0508, October 1984.

5.4 Faint Object Spectrograph (FOS)

The Faint Object Spectrograph (Figure 5-6) is capable of observing the spectra of extremely faint astronomical objects in the ultraviolet and visible wavebands. Study of these spectra will provide information about the physical, chemical, and dynamical nature of the source that is being observed.

The scientific applications of the FOS are numerous and varied in character. A number of possible investigations include: high spatial resolution spectra of quasars, Seyfert and other active galactic nuclei in order to determine physical conditions; observations of H II regions and planetary nebulae in the Local Group Galaxies to measure population abundances; the study of globular clusters in the Virgo Cluster to determine stellar populations and to measure radial velocities; the measurement of the ultraviolet spectra of the central stars of planetary nebulae; time resolved spectrophotometry of X-ray sources; ultraviolet spectrometry of comets to measure various spectral features and some radial velocity measurements of wave structure in cometary tails; and ultraviolet spectropolarimetry of stars and reflection nebulae to help determine the origin of instellar polarization, as well as spectropolarimetry of white dwarfs, quasars, and Seyferts to help delineate the physical processes occurring in these objects.

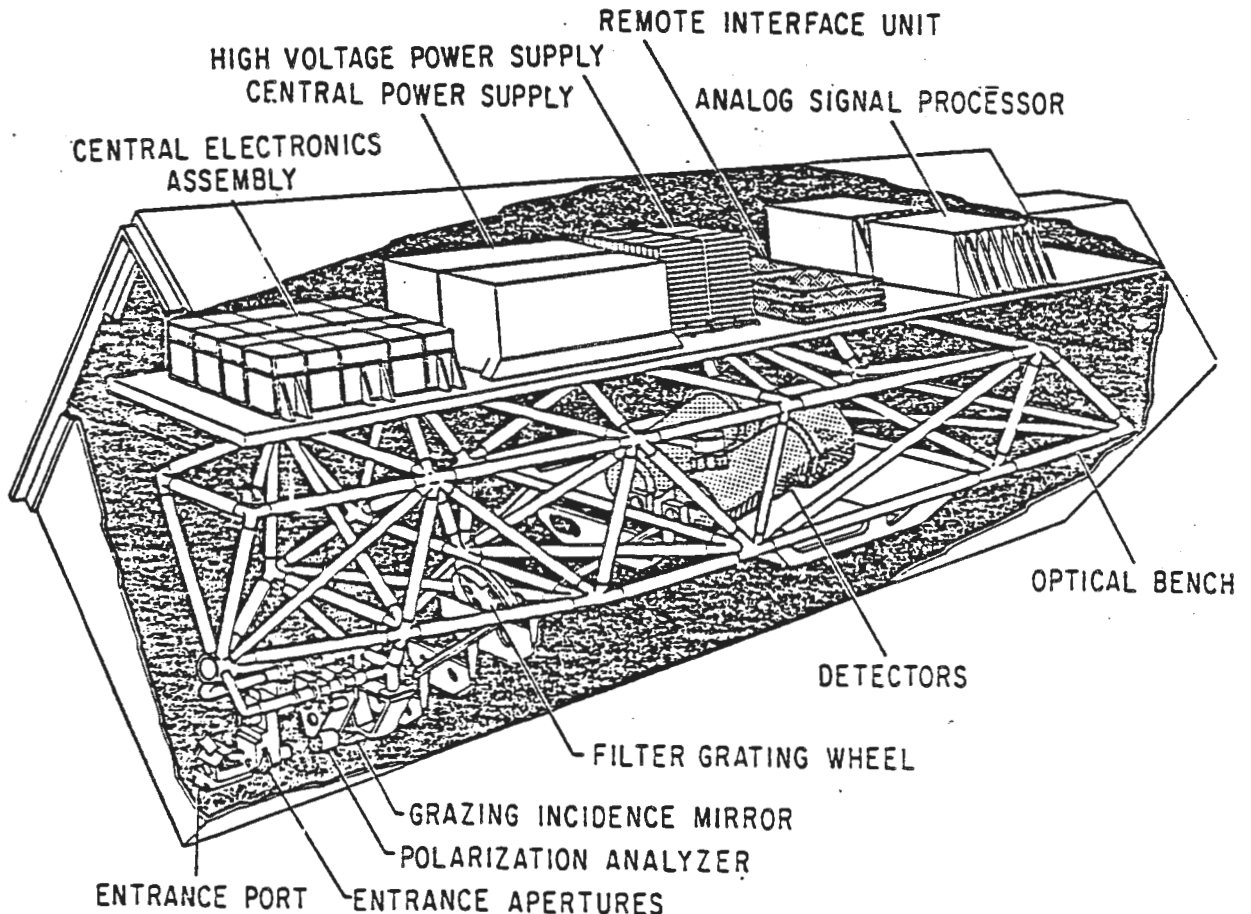

Figure 5-7 Faint Object Spectrograph Performance

31 May 1985

The FOS is a versatile instrument that can perform moderate and low resolution spectroscopy on faint and bright objects in the ultraviolet and visible frequency as well as spectropolarimetry and time-resolved spectroscopy. The basic performance characteristics are listed in Table 5-4.

The FOS provides three modes of varying spectral resolution. The moderate resolution mode has resolution power $R = \lambda / (\Delta \lambda) \sim 10^3$ and provides coverage from 1,150 Å to 9,000 Å in six bandpasses utilizing concave gratings. A low resolution mode, $R \sim 10^2$, consists of three spectral bandpasses - two low dispersion gratings which provide $R = 10^2$ for $1,100 \text{ Å} < \lambda < 2,200 \text{ Å}$ and $4,000 \text{ Å} < \lambda < 8,000 \text{ Å}$ and a sapphire prism spanning the range 1,700 Å at $R = 3 \times 10^2$ to 8000 Å at $R = 20$. There is also a nondispersed image that is used for target acquisition.

The spectrograph contains two identical optical paths which form a spectral image on a red-sensitive and a blue-sensitive detector. Each beam is reflected from a grazing incidence mirror through an order-blocking filter and then onto one of the grating elements selected from a ten-position carousel. The polarizing assembly can be inserted ahead of the grazing mirror assembly to provide linear polarization analysis of the observed source.

The FOS uses two magnetically focused, photon-counting Digicon sensor systems that differ only in their photoemissive cathodes and window materials. Digicon detectors are single-stage, photon-counting devices that operate by re-imaging photoelectrons onto a monolithic linear silicon diode array of 512 diodes. In order to cover the broad wavelength range of the FOS, two independently operable Digicons are used. The ultraviolet/visual sensor has a magnesium fluoride faceplate and a bialkali photocathode. The visible/near-IR sensor has a quartz faceplate and trialkali photo-cathode. Each diode has a width of 40 μm and a height of 200 μm; the image scale at either Digicon is 140 μm per arcsec, corresponding to a magnification of 0.5 of the OTA focal plane.

The FOS is an accurate and sensitive spectrograph over a wide wavelength range. For both the moderate and low resolution modes, the FOS efficiency is expected to exceed one percent over the entire range from 1,200 Å to H-alpha, two percent from 1,200 Å to 2,000 Å, seven percent from 2,000 Å to 4,000 Å, and a peak efficiency exceeding 10 percent. The FOS background noise during inflight conditions is expected to be low: less than 2×10^{-3} counts/sec/diode. The counting rate from a constant source is stable to a one percent accuracy for 99 percent of the diodes over periods up to four hours for all spectral regions in each mode (holding the spectral region and observing mode fixed over the observing period).

The limiting magnitude that is achievable depends on the resolution mode ($R = 10^3$ or 10^2) and the spectral region. The peak sensitivity occurs in the range 4,000 Å to 5,000 Å. The faintest attainable magnitudes are approximately the same from 2,000 Å to 7,000 Å. The sensitivity falls off rapidly below 2,000 Å or above 7,000 Å; at 8,000 Å the typical faintest attainable magnitudes are six magnitudes brighter than at 4,500 Å. Some range of faintest limiting magnitudes attainable in 10^{**4} second exposures are given in Table 5-4.

The indicated limiting magnitudes were computed using the 0.25 arcsec FOS entrance aperture, the FOS efficiencies described above, internal background of 0.002 counts/sec/diode, and a pessimistic sky background. The limiting magnitude is defined to be that which results in 0.01 counts/sec/diode from a stellar target. As another example, note that the FOS achieves a signal to noise ratio of seven per diode at 4,000 Å in the $R = 10^3$ mode for a three-hour integration on an unreddened AOV star of magnitude $V = 23$. Star as bright as $M_v = 6$ m can be observed in the $R = 10^3$ mode.

For spectropolarimetry, the relevant measure is the limiting magnitude for which both of the Stokes parameters describing the state of linear polarization can be obtained with, for example, one-percent accuracy. In a 10^{**4} sec observation, the faintest magnitude for which this accuracy can be achieved in the $R = 10^3$ mode rises monotonically from $M_v = 10.8$ m at 1,200 Å to $M_v = 15$ m at 3,000 Å for a source with a flat spectrum ($F_v = \text{constant}$). For the $R = 10^2$ mode, the faintest magnitudes attainable vary from $M_v = 13$ m to 17 m over the same spectral range under the conditions specified above.

The FOS can provide exposure times as short as 50 μsec duration. A continuous set of exposures, each of duration 50 μsec to 10 msec, can be made at a rate up to approximately 100 512-channel exposures per second. The FOS design also incorporates special entrance apertures matched to the ST optics to maximize the signal from a nebulosity surrounding a stellar source (for example, a quasar that occurs in a galaxy).

| The FOS can perform moderate ($R = \lambda / \Delta \lambda \sim 10^3$ or 10^2) resolution spectroscopy over a wide wavelength range as well as spectropolarimetry and time-resolved spectroscopy. Two photon counting Digicon sensors (512 diodes each) are provided that differ only in their (red-biased or blue biased) photoemissive cathodes. | |
|---|---|
| Characteristics | Expected Performance |
| Spectral Resolution | $R = \lambda / \Delta \lambda \sim 10^3$ $\sim 10^2$ |
| Entrance Apertures | 0.1 to 4.3 arcsec |
| Wavelength Range (FOS system efficiency >1%) | 1,140 Å to 9,000 Å |
| Limiting Magnitudes (no sky contamination; 2×10^3 sec exposure; S/N(detector) ≥ 5) | Mv $\lambda / \Delta \lambda$ = 22 m = 10^3 = 24 m = 10^2 |
| Dynamic Range | $1 \times 10^{**7}$ |
| Photometric Repeatability Precision | at least 1% |
| Time Resolution | |
| - minimum exposure | 50 μ sec |
| - continuous exposures | 100 exposures/sec (10 msec) |
| Linear Polarization Meas. (10^{**4} sec exposure) | 1216 Å to 3000 Å |
| R = 10^3 (flat spectrum) | 11 m < Mv(faintest) < 15 m |
| R = 10^2 (flat spectrum) | 13 m < Mv(faintest) < 17 m |

Table 5-4 Faint Object Spectrograph Performance*

*References: (1) R. Harms (1979), Scientific Investigation Studies Report for the FOS, UCSD Report: FOS-UCSD-SC-01 (February 1979). (2) R. Harms, et al. (1977), UC/MMC FOS for the ST, Technical Volume-Instrument Definition Team, submitted by the University of California to NASA (July 1977).

Table revised by J. M. Vellinga/MMC 10/29/84.

5.5 High Speed Photometer (HSP)

The HSP (Figure 5-7) contains no moving parts and is mechanically the simplest (no moving parts) of the instruments on board the ST. To accomplish its task, it relies completely upon the pinpoint accuracy of the spacecraft's pointing ability. After light has been received from a star or some other source, the brightness or intensity of that light is measured. In addition, this instrument is designed to indicate any fluctuations in brightness on a time scale down to 10 microseconds.

The HSP will be utilized for the observation of rapidly pulsing compact objects, variable stars and binary system; the examination of properties of zodiacal light; the calibration of faint stellar objects; and the examination of specific spikes or flickers of light transmitted from stellar objects, including compact stars and supernova.

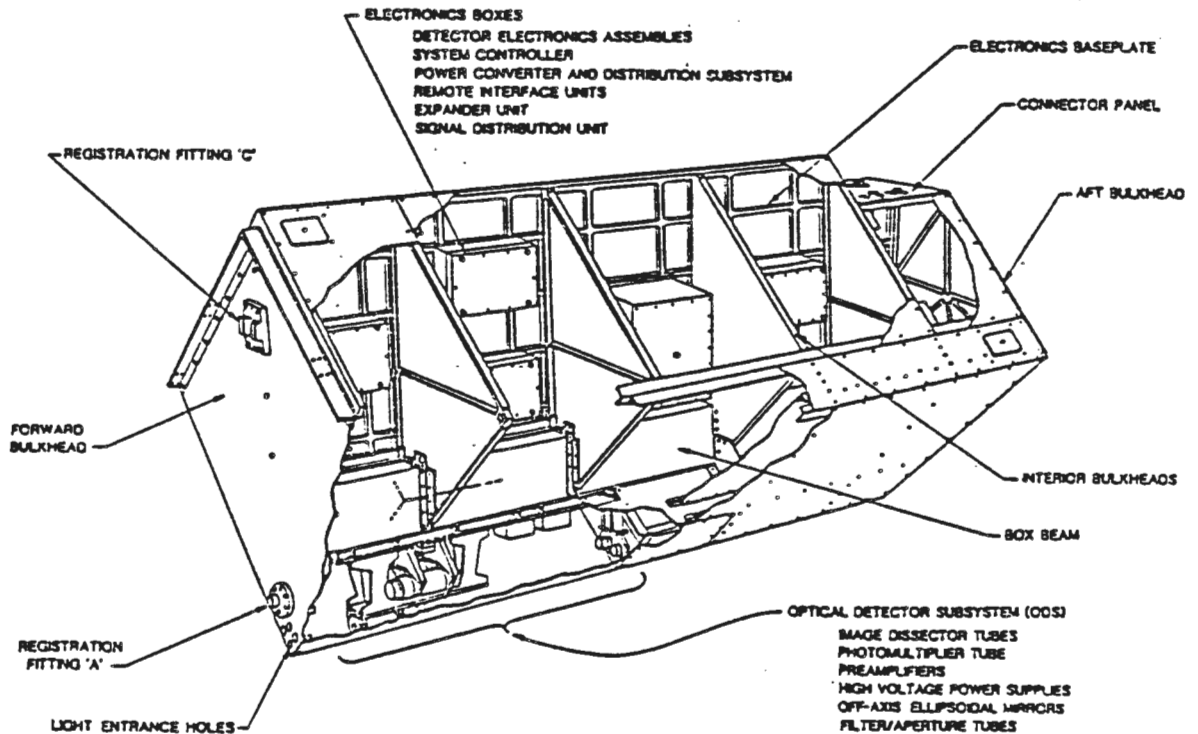

Figure 5-8 High Speed Photometer

The HSP is designed to provide accurate, time-resolved photometric observations over a wide wavelength range, as well as linear polarization measurements in the near ultraviolet. The basic performance characteristics are listed in Table 5-5.

The HSP is capable of resolving two events separated in time by more than 10 microsec. Observations of rapidly varying sources over time scales of this short are difficult or impossible to obtain from the ground because of atmospheric fluctuations. Events measured with the HSP can be related to ground-based time standards with an accuracy of at least 10 msec.

The HSP is designed to be mechanically the simplest instrument in the initial group of scientific instruments. It contains no moving parts and relies entirely on the fine pointing of the spacecraft to place an astronomical target onto one of its approximately 100 filter/aperture combinations.

The HSP consists of four magnetically focused image dissectors (two sensitive in the visual and near UV and two sensitive in the UV) and one (red-sensitive) photomultiplier tube. (For simplicity, one can think of an image dissector as a photomultiplier tube with spatial resolution.) Two dissectors have a nominal S-20 spectral response for operation in the 1,800 Å to 6,500 Å range. Two other image dissectors utilize a CsTe Photocathode with a MgF2 window for operation in the range 200 Å to 3,300 Å. One of the S-20 type dissectors is used as a polarimeter in the 2,100 Å to 3,300 Å range. In addition, the photomultiplier tube utilizes a GaAs photocathode for operation in the 7,500 Å to 8,000 Å range.

The choice of entrance-aperture/filter combination is determined by ST positioning of the optical image within the HSP. This procedure simplifies the instrument design and eliminates the moving parts that occur in a more conventional photometer. Three dissectors are preceded by a focal-plane filter/entrance aperture assembly that contain 13 filters, most with a pair of associated 0.4 arcsec diameter and one arcsec diameter aperture stops. For area photometry without a filter and for target acquisition, a ten arcsec diameter aperture is provided on each dissector faceplate. Standard filters from various photometric systems are included. The filter plate assembly for the polarimeter contains four filter strips each combined with a polarizing film transmitting light plane-polarized in four separate orientations, enabling the linear polarization to be measured in the ultraviolet.

Four operational modes are used: Single Color Photometry; Star-Sky Photometry; Area Scan Photometry over a 10 arcsec diameter aperture without a filter; and Polarimetry. See the HSP System Controller User's Manual for description.

The photometric accuracy at all wavelengths should be very high, of order 0.2 percent or 1.3 times the combined photon noise alone, whichever is larger. The maximum signal-to-noise ratio attainable in a single exposure is at least 4,000; the dynamic range may be as large as 10^{**8} with the photometric accuracy described above for the lowest six decades of the dynamical range. The HSP has a system efficiency of at least 1 percent over the entire range from 1,200 Å to 8,000 Å with a peak efficiency of at least 9 percent at 4,000 Å.

The limiting visual magnitude is 24 with a signal-to-noise ratio of nearly 10 after a 2,000 sec integration on the source.

The HSP makes possible a number of important scientific programs. Some interesting observations include: determination of the properties of components of binary star systems; searches for optical counterparts to radio pulsars; measurement of the shortest time-scales for variability of compact extragalactic sources, accurate brightness measurements of the zodiacal light; determination of the wavelength and time dependence of polarization in a variety of galactic and extra-galactic sources; and measurements of the diameters of stars and solar system objects, as well as determinations of the profiles of the physical parameters of planetary atmospheres. One class of "service" observation is of special importance to the general astronomical community, i.e., the establishment of faint stellar calibration standards, magnitude system transformations, and transfers between previously established photometric sequences and ST targets.

| | |
|---|----------------------------------|
| ----- | |
| The HSP can perform accurate high-time-resolved photometric | |
| photometry over a wide wavelength range. Four image | |
| dissector devices and one photomultiplier tube are used. | |
| ----- | |
| Characteristics | Expected Performance |
| ----- | |
| Wavelength Range (HSP efficiency > 1%) | 1,200 Å to 8,000 Å |
| Spectral Resolution | Defined by Filters |
| Entrance Apertures | 0.4, 1.0, and 10 arcsec diameter |
| Linear Polarization | 2,100 Å to 3,300 Å |
| Time Resolution | 10 µsec minimum |
| Dynamic Range | 10**8 |
| Photometric Accuracy | ~ 0.2% |
| Limiting Magnitude(S/N=10; integration time 2x10 ³ sec) | Mv = 24 m |
| ----- | |

Table 5-5 High Speed Photometer Performance*

*References: (1) R. C. Bless (1977), A HSP/Polarimeter for the ST. A proposal to the NASA by the Space Astronomy Laboratory, U of Wis.; (2) R. C. Bless et al. (1978), HSP GSFC Design Review (CM-04).

Table revised by R. C. Bless 10/17/84.

5.6 Astrometry with the Fine Guidance System (FGS)

The basic layout and description of the FGS is provided in section 3.4.1.1 covering the PCS hardware description, and section 4.4 covering the FGS optical description.

The FGS consists of three identical sensors distributed in an annulus centered upon the optical axis of the ST. Each sensor has its own accessible area (69 arcmin²). In normal operations, two of the sensors are used for fine pointing with the aid of prespecified guide stars. The sensor that is not used for telescope pointing, which can be any one of the three FGS sensors, is available for astrometric measurements. The basic characteristics of the FGS as an astrometric instrument are listed in Table 5-6.

An FGS sensor consists of a set of rotating mirrors such that any star within its FOV can be placed in an interferometer. The encoder readings of the rotating mirror axes supply the object position in the FOV; the output of each of the pair of interferometers supplies a fine error signal. The system determines accurate relative positions to ± 0.002 arcsec (over an integration time of less than two minutes for a star of visual magnitude 17 m of all predesignated point sources within the FOV of the FGS astrometric sensor. The spectral range available is 4,670 Å to 7,000 Å, with appropriate band filters.

With the aid of neutral density filters, stars in the magnitude range of $4 \text{ m} < M_v < 18.4 \text{ m}$ should be measurable (the faint limit will lie between 17 m and 20 m). It is possible to determine the positions of 17th magnitude (visual) stars and to measure 10 stars of magnitude 15 m in 10 min within the field of one of the fine-guidance sensors.

The FGS can be used in three astrometric modes: primary astrometric targets stationary with respect to the FOV; primary target moving with respect to the FOV; and a scan to obtain the transfer function for each object in the FOV.

The FGS can be used for the following: provide positional information of the natural satellites of the outer planets; parallax information on nearby stars and possible unseen companions; resolution of important binaries and mass determinations of nearby spectroscopic binaries; establishment of an inertial reference frame relative to quasars and selected radio sources; and relationships among radio, optical, and dynamical fundamental reference systems.

| Characteristics | Expected Performance |
|---|------------------------|
| Total Area Accessible to Sensor | 69 arcmin ² |
| Relative Positional Accuracy (of any three objects accessible to a given FGS) | 0.002 arcsec |
| Magnitude Range of Targets (with neutral density filters) | 4 m < Mv < 18.4 m |
| Spectral Range (with three filters) | 4,670 A to 7,000 A |
| Duration of continuous observation for temperature stability | less than 20 minutes |
| Photometric Precision (1 minute on a Mv = 17 m object) | 1% |
| Pointing Stability of the ST (10 hours of observing time) | 0.007 arcsec |
| Field of View of Each Detector | 25 arcsec ² |
| Magnitude Discrimination of FGS | ±0.4 m |

Table 5-6 Astrometry with the Fine Guidance System Performance*

*References: (1) W. H. Jefferys et al. (1977), ST Instrument Definition Team - Astrometry; Technical Proposal submitted by the Univ. of Texas (Austin) to the NASA; (2) W. F. Van Altena et al. (1977), Space Telescope Instrument Definition Team - Astrometry; Technical proposal submitted by Yale University Observatory to the NASA; (3) P. J. Shelus and the ST Astrometry Team (1978) Astrometric Observations with the FGS of the ST technical report, University of Texas (Austin).

5.6.1 Fixed Field

In this mode, the star selectors are commanded to look for a star and, when sufficient signal to noise has been accumulated, to output the encoder reading, flux count, filter used (prespecified), interferometer error signal as a function of the time throughout the exposure, and engineering parameters. This process is repeated for several objects within the FGS FOV.

5.6.2 Moving Targets

This mode produces exactly the same kind of output as does the fixed field mode above, but during the exposure the ST is either fixed (and the third FGS is "following" the object) or moving so as to fix the object in the third FGS.

5.6.3 Intensity Transfer

In this mode the third FGS is in an open loop (so that it is not null-seeking) and each of the objects designated is scanned across the interferometer FOV. At each step of the scans, the same data are read out as above (error signal, flux, filter used, etc.).

Note that in astrometry calibration operations and in some astrometry observations, the specific FGSs for doing astrometry are cycled through the set of three on each group of targets. By repeating the measurements with several sets of the FGSs in this way, the smallest systematic errors in the data can be identified during analysis.

6.0 SI CONTROL and DATA HANDLING (SI C&DH)

The SI C&DH subsystem provides the communications link between the Support Systems Module/Optical Telescope Assembly (SSM/OTA) and the Scientific Instruments (SIs). The components of the SI C&DH are all located in Bay 10 of the SSM Equipment Section (SSM-ES), except for 10 of the Remote Modules (RMs) and their Bus Coupler Units (BCUs). The RMs, which consist of a Remote Interface Unit (RIU) and, if required, up to two Expander Units (EUs), provide the command and engineering data interface with the SI C&DH and the SIs. The SI RMs are physically attached to the SIs. Their BCUs are in the OTA. The other components of the SI C&DH are mounted in the SSM on a removable shelf designed for in-orbit replacement, as a single unit, by a suited astronaut.

The SI C&DH subsystem is required to perform the following functions:

- 0 Provide system hardware redundancy under ground control.
- 0 Receive +28 V unregulated power from the SSM.
- 0 Control power conditioning and distribution within the SI C&DH.
- 0 Receive and distribute clock and synchronization signals.
- 0 Receive, distribute, and execute realtime commands.
- 0 Communicate with the SSM-DMS via Processor Interface Tables (PITs).
- 0 Report SI C&DH status to the SSM via Engineering Data (ED).
- 0 Collect SI ED for on-board use of transmission to the SSM.
- 0 Receive, format, and encode Science Data (SD) from the SIs.
- 0 Transmit SD to the SSM or process it on board.
- 0 Provide a computer facility for SI control and data manipulation.
- 0 Issue a pre-stored payload safing command sequence.

All information to or from the SIs passes through the SI C&DH or, to be more exact, through the Control Unit/Science Data Formatter (CU/SDF) of the SI C&DH. Therefore, it is not possible to send commands to the SIs or to collect data from them unless the CU/SDF is on and operating. It is possible to command the SIs and to collect SD and a very limited amount of ED from them without involving the NSSC-I computer in the SI C&DH. The NSSC-I is involved in the monitoring and control of the SIs. Operation of the SIs in anything but the hold or safe mode without having the NSSC-I fully operational should be considered only under the most extreme circumstances.

The SI C&DH is a variation of the Communication and Data Handling (C&DH) module of the Multimission Modular Spacecraft (MMS). The SI C&DH Power Control Unit (PCU), Standard INTERface (STINT) for Computer RIU, EU, BCU, and NSSC-I are all based on Standard Telemetry and Command Components (TRACC) designs developed for MMS. In some cases, modifications to STACC designs have been made to accommodate the unique requirements of the Space Telescope. Although the CU/SDF is substantially new design, parts of it are based on the STACC central Unit design. The NSSC-I software executive for the SI C&DH is based on the NSSC-I executive developed for MMS and contains many of the same features.

6.1 SI C&DH Electronic Components

The SI C&DH (Figure 6-1) equipment consists of a mounting tray to which are attached a number of electronic boxes. The complete tray is an Orbital Replacement Unit (ORU), and has provisions for safe Extravehicular Activity (EVA) handling. No mechanisms are included in the SI C&DH equipment.

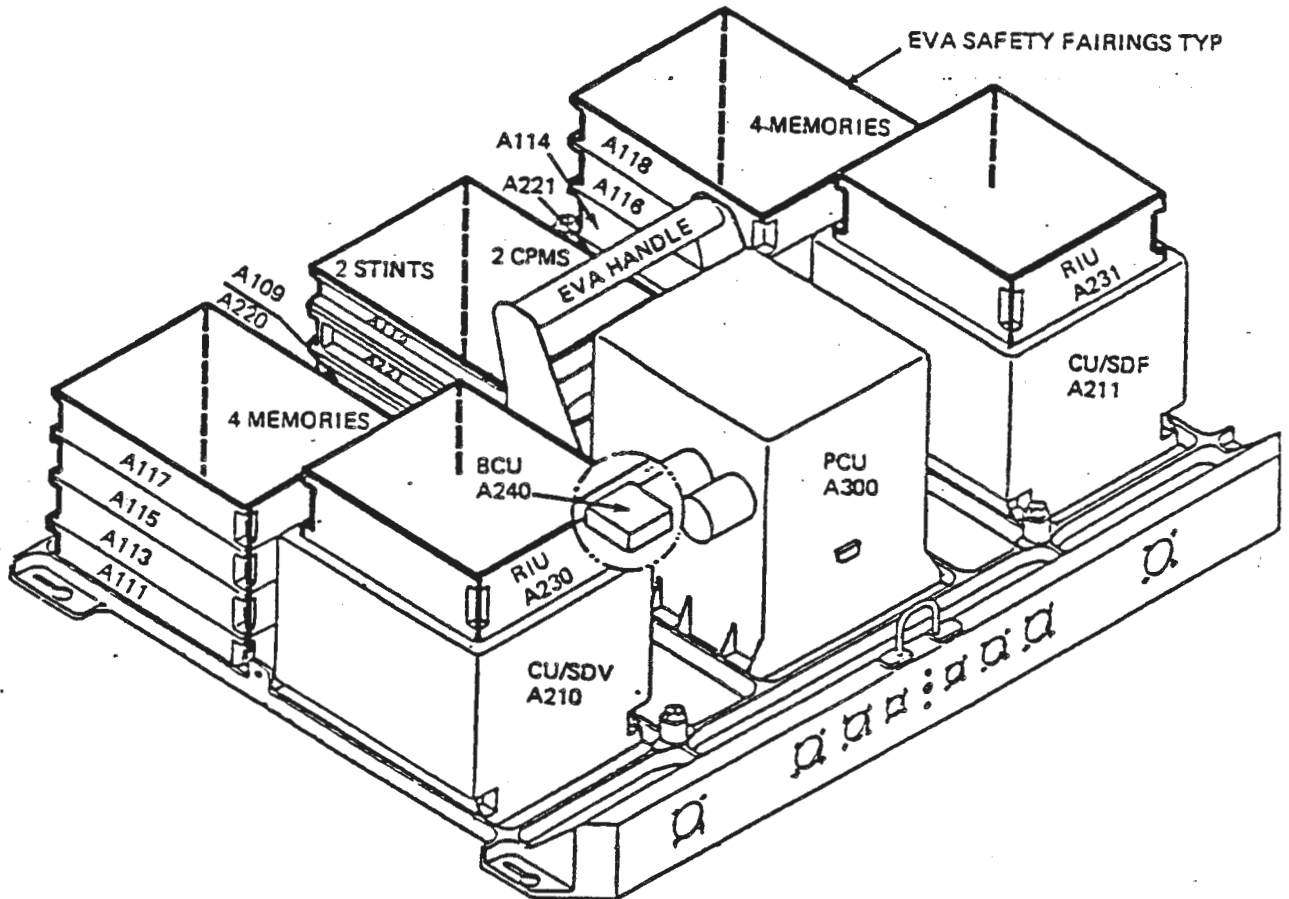

Figure 6-1 SI Control & Data Handling

6.1.1 NASA Standard Spacecraft Computer-Model I (NSSC-I)

The NSSC-I consists of a Central Processor Module (CPM) and eight memory modules which each contain 8192 18-bit words. The NSSC-I software consists of an "Executive" and "SI-unique Application Processors". The "Executive" provides the functions of input/output control, delayed command storage, execution ED collection and limit checking, Processor Interface Table (PIT) processing, diagnostics and processor scheduling and control. The "SI-unique Application Processors" are defined by the SI teams and perform required functions of SI control, monitoring, and data manipulation/analysis.

6.1.2 Standard Interface for Computer (STINT)

The STINT is a STACC unit used on ST without modification and provides the interface between the CU/SDF and the NSSC-I; to the SI C&DH subsystem user, it is functionally transparent.

6.1.3 Control Unit/Science Data Formatter (CU/SDF)

The CU/SDF is the central hub of the SI C&DH and performs the following functions:

0 It receives a 1.024-MHz square wave clock signals from the SSM DMU and transmits it to the SIs via the MDB. This signal is used as the basis for all SI C&DH clock and synchronization signals.

0 It receives a Master Timing Pulse (MTP) from the SSM DMU and uses it for telemetry and processing synchronization.

0 It receives ground commands in a 27-bit format via a three-signal (enable, clock, and data) interface with the SSM DMU, reformats the commands, and transmits them either to the SIs via the MDB or to the NSSC-I via the STINT.

0 It receives SSM commands in a 16-bit format via a three-signal (enable, clock, and data) interface with the SSM DIU, reformats the commands, and transmits them either to the SIs via the MDB or the NSSC-I and the STINT.

0 It reads sets of engineering data requests from the NSSC-I via the STINT, reformats them, and transmits them to the SIs via the MDB.

0 It reads engineering data replies (one per request) from the SIS via the MDB and transmits them to the NSSC-I via the STINT.

0 It reads completed minor frames of SI and SI C&DH engineering data from the NSSC-I via the STINT and transmits them to the SSM via a three-signal (enable, clock, and data) interface with the SSM DIU.

0 Under certain abnormal conditions, it reads sets of 64 fixed engineering data requests from an internal ROM, transmits them to the SIs via the MDB, collects the replies from the SIs via the MDB, and provides the replies to the SSM via the Engineering data interface in lieu of the normal minor frames of engineering data.

0 It receives science data from the SIs via dedicated six-signal interfaces and transfers the data to the NSSC-I via the STINT.

0 It receives science data from the SIs via the six-signal interfaces or science data, data logs, and NSSC-I memory dumps from the NSSC-I via the STINT; formats the data into packets; optionally adds a pseudo-random noise sequence and/or Reed-Solomon error correction encoding; and transmits the resulting data as a continuous bit stream to the SSM via a two-signal (clock and data) interface with the SSM DMU. "Science data" from the SIs can be raw or processed detector outputs, SI health and status information, or SI microprocessor memory dumps. Data logs from the NSSC-I can contain any information (including forward linked data and SI microprocessor memory dumps) collected in the NSSC-I under control of the NSSC-I Executive or an SI Application Processor. NSSC-I memory dumps each contain the contents of one of 16 4096-word banks of NSSC-I memory.

6.1.4 Power Control Unit (PCU)

The PCU is a modification of a STACC unit and performs power switching and distribution for all the components on the SI C&DH Orbit Replaceable Unit (ORU) tray and performs power conditioning for some of those components. The PCU is internally redundant. It receives +28 Vdc unregulated power from the SSM on two independent, redundant power buses. It also receives four high level discrete commands from each of the redundant SSM Command Data Interfaces (CDIs). The PCU provides +28 V unregulated power to the CU/SDF and RMs; +5 V regulated power to the Central Processor Modules (CPMs), STINTs, and oscillators; and +5 V, -5 V, and +12 V regulated power to the NSSC-I memory modules. The PCU contains redundant 1.8-MHz oscillators which generate clock signals that are provided to the CPMs via the STINTs.

6.1.5 Remote Module (RM)

The RM is a STACC unit which has been modified somewhat for use on ST. Each RM consists of a Remote Interface Unit (RIU) and from zero to two Expander Units (EUs). Each RIU provides eight lines for input of serial digital commands, 64 lines for output of discrete (relay or logic) commands, and 64 lines for sampling serial digital, active analog, conditioned analog, and bi-level telemetry points.

On ST, the RMs are used in redundant pairs. Only one unit of each pair is fully active at any point in time. There are six such pairs used on ST, one for each of the five SIs and one for the SI C&DH. All active RMs monitor all messages on the Supervisory Bus but only the RM that is addressed responds to a given message.

Except for science data, the RMs provide the interface between the SIs and the SI C&DH. They accept serial digital command messages from the MDB and provide the commands to the SIs as either 16-bit digital messages or 35 msec pulses/ground connections on discrete lines. In response to engineering data requests, they clock in 8-bit serial digital samples from the SIs or provide bi-level sampling and analog-to-digital conversion as required and transmit 9-bit engineering data replies on the MDB.

6.1.6 Bus Coupler Unit (BCU)

The BCU is a device which transformer couples two RMs to the MDB so that a failure in a RM will not affect the MDB or other RMs attached to the MDB. The BCU is a Standard Telemetry and Command Components (STACC) unit to which connectors have been added for use with cabling provided by the OTA.

6.1.7 Multiplexed Data Bus (MDB)

The MDB consists of a Supervisory Bus and a Reply Bus, both of which operate at 1.024 MHz. The Supervisory Bus is operated in a repeating sequence of four 32-bit slots which contain synchronization messages, commands, and engineering data requests addressed to the various RMs.

6.2 SI C&DH Component Function

The ways in which the various SI C&DH components function together to meet the subsystem mission requirements are discussed in the following subsections.

6.2.1 Command Handling

Command inputs to the SI C&DH consist of four high level discrete commands from each Command Data Interface (CDI) and serial digital commands input over either the 27-bit interface with the CDI or the 16-bit interface with the Data Interface Unit (DIU). The high level discrete commands switch relays in the Power Control Unit (PCU) and require no interpretation or handling by the SI C&DH. Figure 6-2 shows the serial command information flow through the SI C&DH.

Commands reach the SI C&DH from the SSM over either the 27-bit or 16-bit command interface. With the exception of SSM PIT words, which are transferred over the 16-bit interface only, all command inputs to the SI C&DH may be made over either interface.

All commands input to the SI C&DH are treated by the SI C&DH as Real-Time Commands (RTCs). The fact that they may be stored program commands (SPCs) or Computer Program Commands (CPCs) from the DF-224 computer in the SSM is transparent to the SI C&DH. The incoming commands are checked for proper parity, type code, and word order in the CU/SDF. Correct commands are reformatted and transferred to other parts of the SI C&DH.

Discrete and serial magnitude commands are transmitted on the Supervisory Bus to the RMs pass the commands along to the appropriate user circuits. In the SI C&DH, discrete commands are used for power switching in the PCU, and serial magnitude commands are used for data input and logic control in the CU/SDF.

Computer commands are transferred from the CU/SDF to the STINT via DMA 4 and 5. Some computer commands cause the STINT to put into a specified NSSC-I memory address an 18-bit data word contained in the command. SSM PIT words are transferred to NSSC-I memory via the STINT on DMA 1.

Through the medium of computer commands, the images of sequences of commands to be executed subsequently may be stored in NSSC-I memory. Sequences which do not require modification by NSSC-I application software (SPCs) are stored in a stored command memory with a minimum of 6144 18-bit words. Sequences which require modification by NSSC-I application software (CPCs) are stored in the portions of memory assigned to the various SIs. Once stored, a given sequence may be activated by SPC, CPC, or a request from application software.

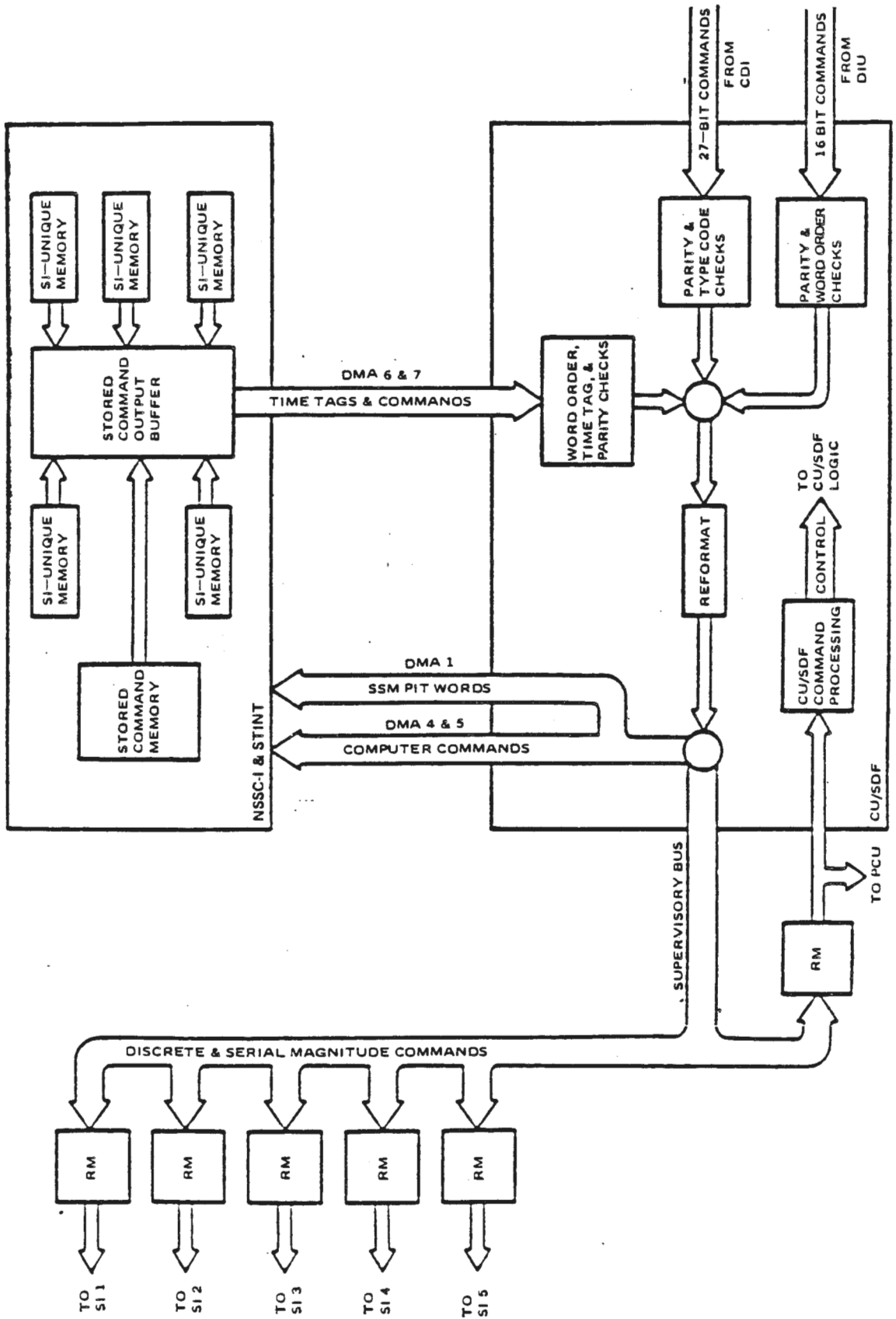

Figure 6-2 Command Information Flow

To preclude interference from multiple, asynchronous, active command sequences, the NSSC-I Executive software is designed to permit only one active sequence for a given SI at any time. To implement this restriction, the NSSC-I Executive software provides multi-level, nonreentrant nesting of stored command sequences.

Once every 25 msec, the Stored Command Processor (SCP) of the NSSC-I queries the active stored command sequences to see which have commands scheduled for execution in the next 25-msec interval. All such commands are assembled in a stored command output buffer. Ahead of each command image (27 bits) in the buffer, the SCP places a 27-bit time tag word which contains a flag telling the CU/SDF to execute the command immediately. Upon receipt of the next 25 msec interrupt from the CU/SDF, the NSSC-I outputs the contents of the stored command buffer to the CU/SDF via the STINT, using DMA channels 6 and 7.

The CU/SDF checks the incoming DMA 6 and 7 information for proper sequencing of time tags and commands and tests each time tag. Upon sensing the "Execute Immediately" flag, the CU/SDF reads the command which follows and tests its parity. Correct commands are then processed as though they were received as RTCs over the 27-bit command interface with the SSM.

6.2.2 Processor Interface Table (PIT) Handling.

The flow of PIT information through the SI C&DH is shown in Figure 6-3. A full SSM/SI C&DH PIT exchange occurs once every 500 msec, so long as the NSSC-I and DF-224 are both operating normally. Synchronization of PIT-related operations is accomplished through the Master Timing Pulse (MTP). Transfers of PIT information are constrained to occur within certain time intervals related to each MTP.

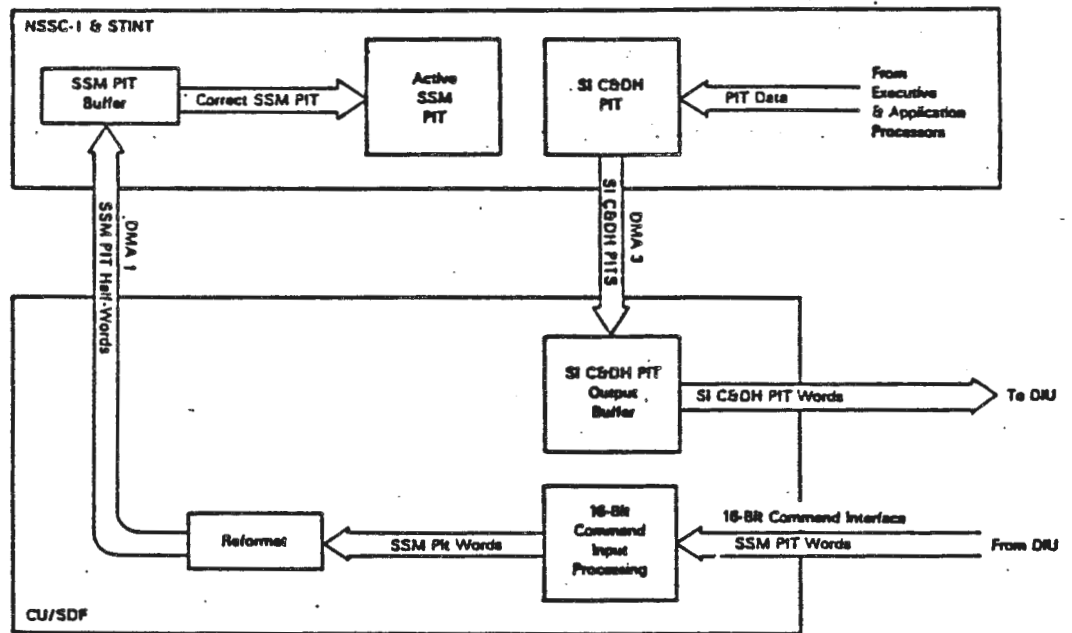

Figure 6-3 PIT Information Flow

SSM PIT words are input to the SI C&DH via the 16-bit command interface between the DIU and the CU/SDF. When the CU/SDF determines that it has received an SSM PIT word, it divides the 16-bit word into two 8-bit halves and inputs them to the NSSC-I via the STINT over DMA 1, high order half first.

The NSSC-I stores the eight-bit half-words in a buffer until it has received a complete SSM PIT. It then checks a data quality flag in the PIT data. If the PIT is correct, the NSSC-I Executive reassembles the 16-bit words and stores them in the active SSM PIT area, from which they may be accessed by application software. If a complete, correct PIT is not received within the specified time interval, the NSSC-I Executive does not update the active SSM PIT in memory.

Throughout each 500 msec PIT interval, the NSSC-I Executive and application software may cause information to be written in the SI C&DH area of NSSC-I memory. At the start of the next PIT interval, the NSSC-I writes the contents of the SI C&DH PIT area to the CU/SDF via the STINT on DMA 3. The CU/SDF holds the SI C&DH PIT words in an output buffer, from which they are read by the SSM over a 16-bit interface to the DIU.

6.2.3 Timing and Synchronization

Operations throughout the Space Telescope are synchronized through three synchronous signals generated in the SSM: a 1.024-MHz square wave clock, a 32-bit time code with a Least Significant Bit (LSB) of 125 msec, and the Master Timing Pulse (MTP). The flow of this information through the SI C&DH is shown in Figure 6-4.

The 1.024-MHz clock signal received from the timing module of the SSM DMU is used by the CU/SDF to control a Phase-Locked Loop (PLL) which generates all the timing signals used and/or distributed by the SI C&DH. The primary output of the PLL is a 1.024-MHz square wave clock which drives the CU/SDF master timer and is distributed to all SIs via the Supervisory Bus and the RMs. The CU/SDF timing circuitry also generates 25-msec interrupts (Interrupt 5) for the NSSC-I.

Nominally once every 60 sec, the SSM PIT contains a new value of the 32-bit SSM time code, valid at the next subsequent MTP. The NSSC-I Executive reads the new time code value when it is placed in the active SSM PIT area, saves it for subsequent updating of the NSSC-I timer, and places it in CPCs for transmittal to the CU/SDF and any SIs that wish to receive it. The time code update CPCs are transmitted through the CU/SDF, Supervisory Bus, and RMs. The CU/SDF receives the time code update commands addressed to the SI C&DH and saves the new time code for subsequent updating of the CU/SDF timer. The SIs that receive time code update commands proceed in a similar manner

As its name implies, the MTP is the master synchronization signal for the SI C&DH and SIs. The interval between successive MTPs can be 500 msec, five sec, or 40 sec, depending on the engineering data format used by the SSM. If the MTP interval is other than 500 msec, the NSSC-I does not operate, and there is no exchange of PITs.

When the CU/SDF receives a MTP, it immediately restarts the Supervisory Bus timing cycle and transmits a special synchronization message which is broadcast to all RMs. This message always contains a minor frame start flag.

If the CU/SDF received a complete set of time code update commands during the preceding 500 msec interval, the synchronization message also contains a major frame start flag. These flags cause the RMs to issue special synchronization pulses which can be used by the SIs.

When the CU/SDF receives a MTP, it sends Interrupt 6 to the NSSC-I. This interrupt causes the NSSC-I to repeat all those operations which it is programmed to perform once per MTP. If a time code update was received during the preceding 500 msec interval, the NSSC-I updates its internal timer with the new time code value. Between time code updates, the NSSC-I timer is advanced by each 25-msec interrupt.

Receipt of the MTP which immediately follows a set of time code update commands causes the CU/SDF to clear its 42-bit internal timer, load the 32 High-Order Bits (HOB) of the timer with the saved time code value, and start counting up the timer again with the 1.024-MHz clock from the PLL. The current value of the 42-bit CU/SDF timer (LSB approximately 122 microseconds) is used to time stamp every packet of science data transferred to the SSM.

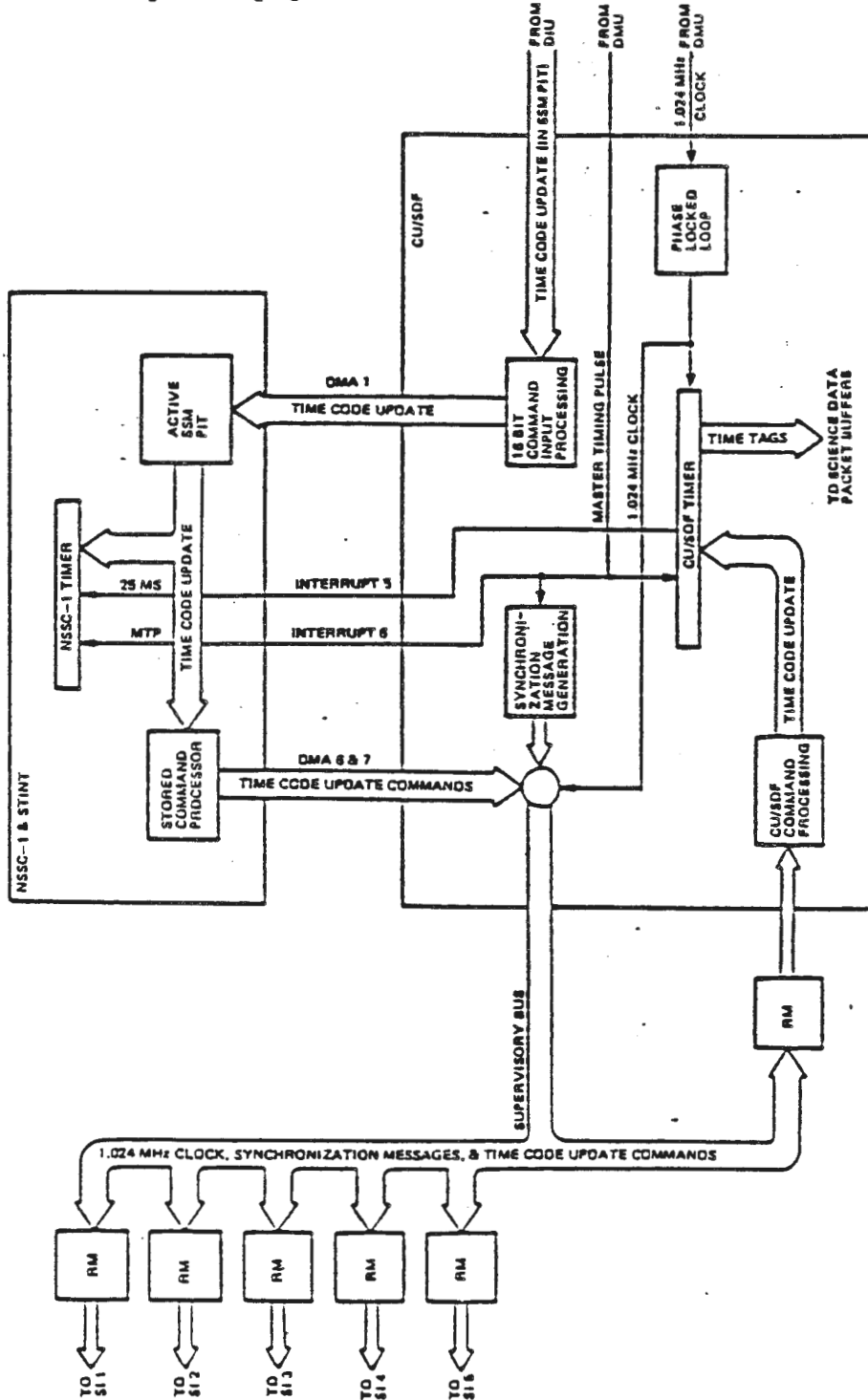

Figure 6-4 Timing and Synchronization Information Flow

6.2.4 Engineering Data (ED) Handling

Each MTP causes the SI C&DH to collect status information from itself and the SIs and to make this information available for subsequent reading by the SSM and/or NSSC-I application software. The flow of this status information, known as ED or telemetry, through the SI C&DH is shown in Figure 6-5.

During the "normal" mode of ED handling, which is used whenever the NSSC-I is operating normally, collection of ED is controlled by tables of telemetry requests stored in NSSC-I memory. These tables specify not only the ED that is to be collected for subsequent output to the SSM but also that which is collected solely for the use of on-board application software. At the start of each 500 msec MTP interval, the NSSC-I outputs to the CU/SDF over DMA 2 the requests for ED to be provided to the SSM, followed by sets of requests for ED collected for the use of NSSC-I application software.

The CU/SDF reads the telemetry requests at two msec intervals, reformats them, and transmits them to the various RMs on the Supervisory Bus. For each telemetry request addressed to it, a RM nominally responds with a single eight-bit serial digital reply, which it transmits to the CU/SDF on the Reply Bus, preceded by a single synchronization bit. The CU/SDF forwards each reply to the NSSC-I over DMA 0. If for any reason the CU/SDF does not receive a reply to a given telemetry request, it provides to the NSSC-I a word of zeros to maintain request/reply synchronization. The NSSC-I Executive stores the replies in the Current Value Table, designated portions of memory assigned to the various SIs, and/or the ED output buffer.

For situations in which the NSSC-I is not operating, the SI C&DH provides a "fixed" mode of ED handling. In the fixed mode, each MTP caused the CU/SDF to read a single set of 64 fixed telemetry address requests from Read Only Memory (ROM) and output them on the Supervisory Bus. The resulting replies are stored in the output buffer not currently available for reading by the SSM. As is done in the normal mode, the CU/SDF supplies a word of zeros for each missing reply. At each MTP, the status of the two output buffers is switched, so that ED words collected during one MTP interval may be read by the SSM during the next interval. The NSSC-I plays no part in fixed mode ED handling.

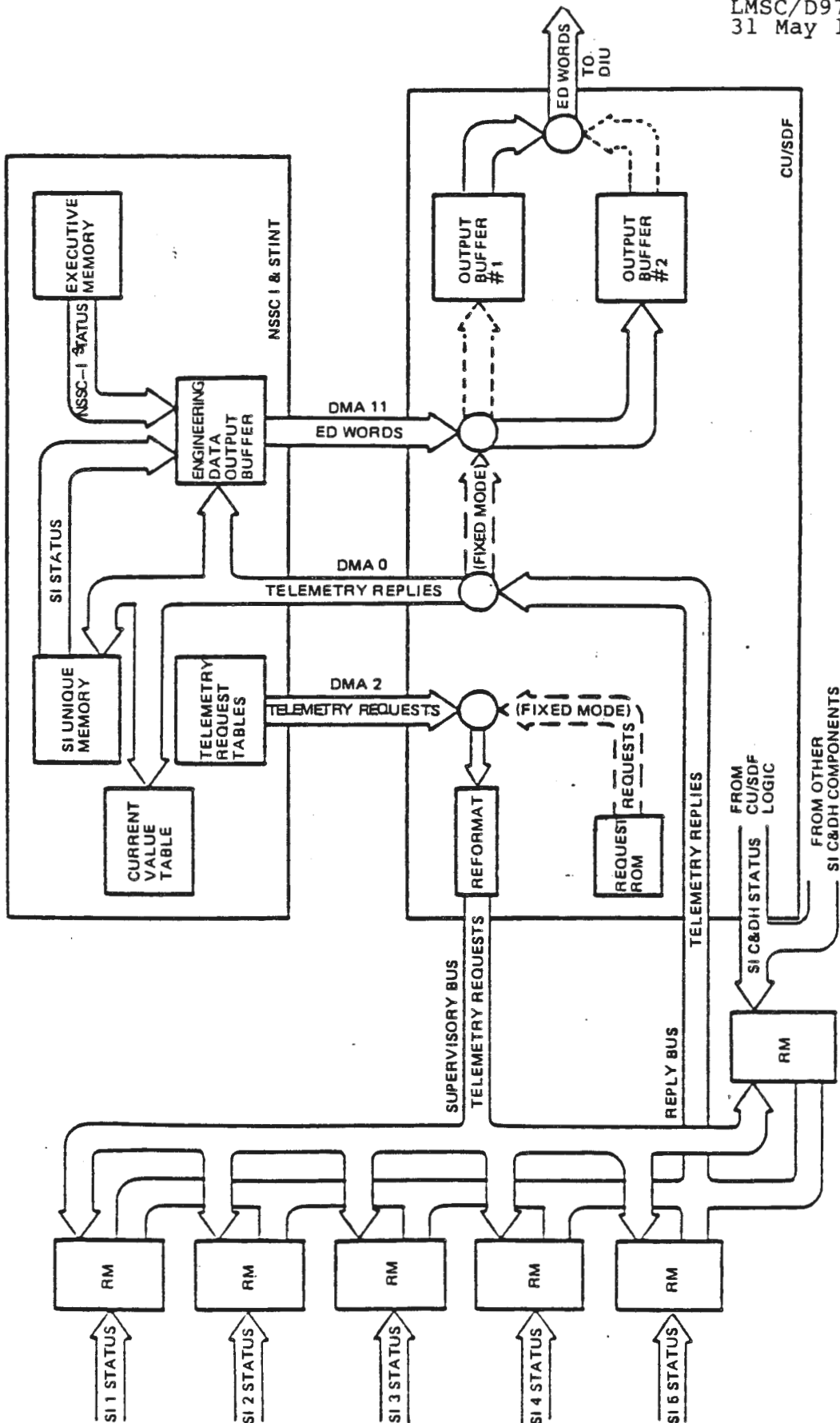

Figure 6-5 Engineering Data Information Flow

6.2.5 Science Data (SD) Handling

The CU/SDF can accommodate concurrent inputs of raw SD from each of five SIs and processed SD or various types of data logs from the NSSC-I. This concurrent operation is accomplished by interleaving the inputs from all active SD sources on a line (i.e., packet) basis. SD flow within the SI C&DH is governed by logic switches and format specifications whose status is controlled by various serial digital commands executable as RTCs, SPCs, or CPCs. The flow of SD and SD control information through the SI C&DH is shown in Figure 6-6.

SD input from a SI begins with a request from that SI to the CU/SDF. Upon receipt of such a request, the CU/SDF conducts a control word dialog with the NSSC-I via DMAs 3 and 8. If the NSSC-I has been conditioned properly, the results of this dialog are affirmative, and the transfer is begun as soon as a packet buffer is available. A single line of SD is read into one of two packet buffers, which are operated in "ping pong" fashion. The data transfer is controlled by a format specification stored in Random-Access Memory (RAM).

Once in the CU/SDF, SI C&DH input may be sent to either the NSSC-I or the SSM. This choice is governed by destination switches which are independent for each SI. If the destination is the SSM, the ancillary data required by the packet format and a time tag read from the CU/SDF timer are added, and the completed packet is output to the SSM as soon as the output channel is free. If the destination is the NSSC-I, no additional information is added, and the line of raw SD is transferred to the NSSC-I via DMA 8.

Processed SD and data logs from the NSSC-I are handled the same way, except that the data is transferred over DMA 3 instead of over a dedicated six-signal interface. The format specifications for two types of data logs (Standard Header Packets and Status Buffer dumps) are kept in ROM and cannot be modified by commands, and the data destination is always the SSM.

NSSC-I memory dumps preempt all other SD transfers. Consequently, they are to be commanded only by RTC and only when no other SD operations are scheduled. The dump data is input to the CU/SDF in an unbroken stream from the STINT via DMA 14. The CU/SDF packetizes the dump data according to a ROM-stored format (50 packets per dump) and outputs each completed packet to the SSM.

Once the CU/SDF begins to output SD to the SSM, it must keep the output channel filled in order to maintain synchronization. However, the incoming SD is not always sufficient to fill the output channel. For example, at the highest NSSC-I dump rate (32 kbps), a packet which is output in only 13 msec at the corresponding 1.024 Mbps output rate requires almost 375 msec for input to the CU/SDF. To keep the output channel busy, the CU/SDF outputs a 64-word filler packet whenever there is no other completed SD packet available for transmission.

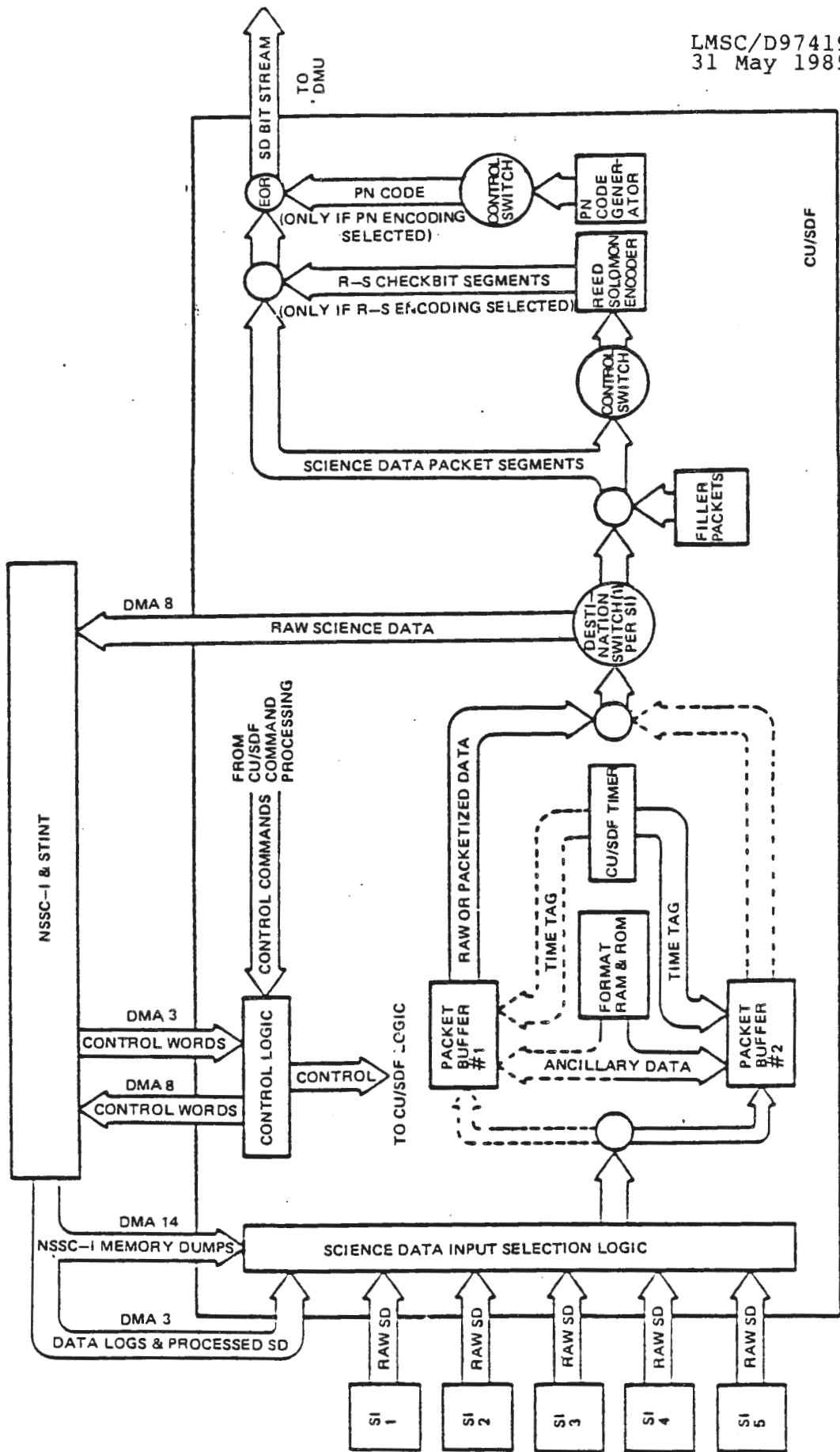

Figure 6-6 Science Data Information Flow

31 May 1985

As a commandable option, Reed-Solomon (R-S) error correction encoding can be added to the SD output by the CU/SDF to the SSM. If R-S encoding is selected, the SD output stream is input to the R-S encoder at the same time it is transferred to the SSM. After each set of 14 64-word SD segments (without regard to packet boundaries), the flow of SD is suspended long enough to insert one 64-word segment of R-S checkbits after every 14 segments of data. A pseudorandom noise (PN) code may be added to each segment of SD output to the SSM by an exclusive process. The PN code is a 255-bit sequence which is repeated as necessary and is restarted at the beginning of each 1024-bit segment.

7.0 SOLAR ARRAY (SA)

The SA will be operated from the Space Telescope Operations Control Center (STOCC). Mission Operations involve the SA deployment of the two wings, SA rotation for normal operations, SA rotation for stowage operation and SA wing retraction.

7.1 SA Configuration

The SA (Figure 7-1) consists of two fully interchangeable wings with a rated two year power output of 4,000 W at 34 V. Each wing is comprised of two flexible solar cell blankets that are deployed by the secondary deployment mechanism. Each blanket is comprised of five SA panel assemblies (ten per wing). Each panel assembly contains 2,438 cells for a total SA cell count of 48,760. The SA also consists of a diode box, supporting structure, instrumentation, cushion blanket, storage drum, and the deployment retraction and orientation mechanisms.

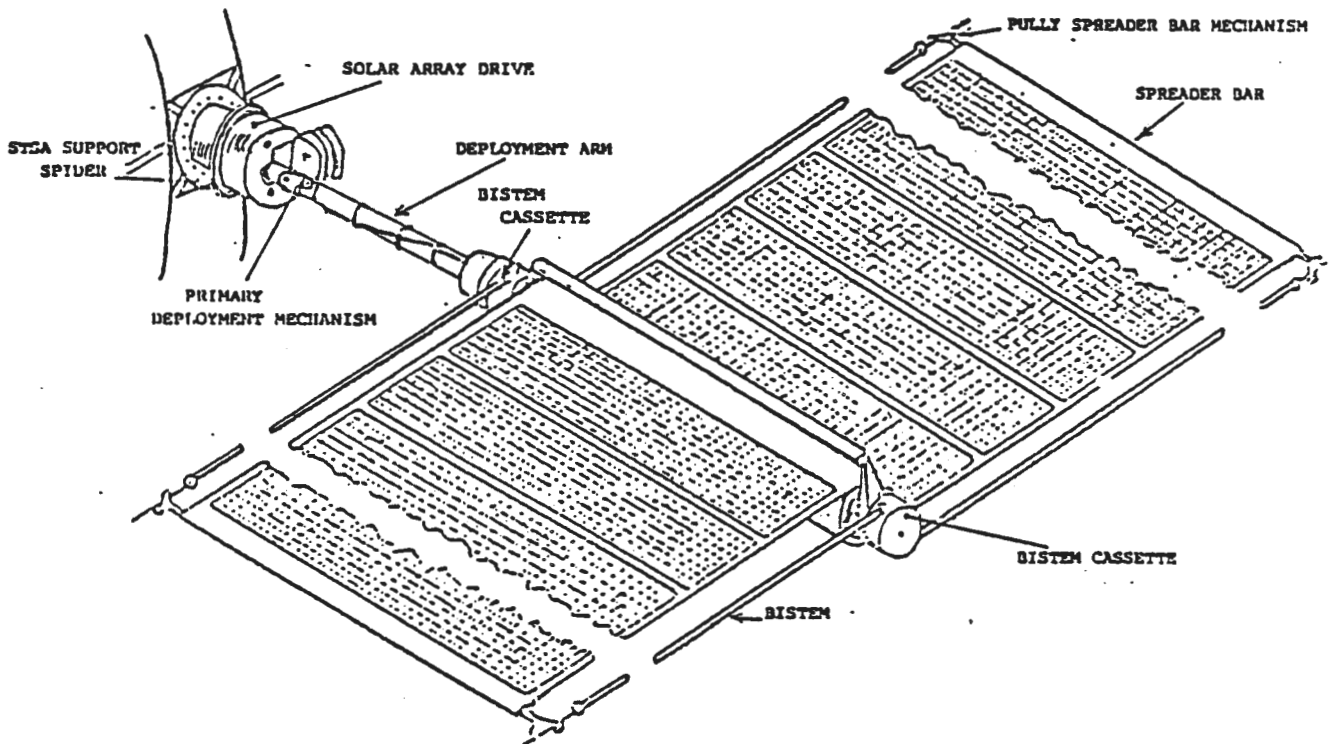

Figure 7-1 SA Secondary Deployment Mechanism

The deployment mechanism interfaces via an adapter with the SA Drive Mechanism (SADM). The deployment and unfurling mechanisms are controlled by the Deployment Control Electronics (DCE). The two SADMs are controlled by the SA Drive Electronics (SADE). The SA DCE and SADE, jointly referred to as the Electronic Control Assembly (ECA), are mounted in Bay 7 of the SSM ES.

7.1.1 Electrical Power Subsystem (EPS)

The SA electrical power is generated by the solar cell panels and is passed to the SSM EPS for conditioning and distribution. Power for all SA motors and instruments is controlled by the Electronic Control Assembly (ECA), which also accepts commands from the SSM and conditions data from the SA system for transmission to the SSM Digital Interface Units (DIUs).

7.1.2 Summary Weights and Mass Properties

| Mass Breakdown | Mass (kg) |
|--|-----------|
| SAD Adapter including thermal items | 3.48 |
| SA Drive including thermal items | 21.59 |
| Primary Deployment Mechanism (thermal and harness) | 21.15 |
| Secondary Deployment Mechanism (thermal) | 56.43 |
| Solar Cell Array (two blankets) | 37.30 |
| Fittings, loose harness and thermal items | 1.06 |
| | ----- |
| Mass of one Wing Assembly | 141.01 |
| Diode Box (BAe parts only) | 3.13 |
| Mass of Two Wing Assemblies | 288.28 |
| Deployment Control Electronics | 8.82 |
| Solar Array Drive Electronics | 14.40 |
| | ----- |
| Total Mass of complete Solar Array | 311.50 |

Center of Gravity: The center-of-gravity information quoted uses the S axes defined in Figure 2-3 and are based upon a SA wing mass of 139.95 kg which does not include the mass of the Diode Box or its connecting harness.

Stowed: S1 = -0.003 m, S2 = +1.790 m, S3 = +0.420 m
 Deployed: S1 = +0.001 m, S2 = +2.211 m, S3 = +0.023 m

Moments of Inertia: The Moments of Inertia (kg-m) information are based upon a SA wing mass of 139.95 kg which does not include the mass of the Diode Box or its connecting harness. The values given are with respect to the center of gravity defined above.

Stowed: Is1 = 314.261, Is2 = 3.616, Is3 = 312.726
 Deployed: Is1 = 326.246, Is2 = 613.707, Is3 = 937.672

The deployed SA is unfurled for the above tables values.

7.1.3 SA Description

7.1.3.1 Stowed Configuration

In the stowed configuration (Figure 7-2) the main structure consists of the Primary and Secondary Deployment Mechanism (PDM) and (SDM), the SDM being mounted upon the spar tube. The SA drum is mounted concentrically on the spar plates by bearings at each end. The SA blanket cushion roller is mounted above the SA drum and carried by two machined, light alloy supports attached to the spar tube, adjacent to each end of the drum. At each end of the SA drum is mounted the bi-stem cassette carriers which in the stowed position provide support to the blanket spreader bars.

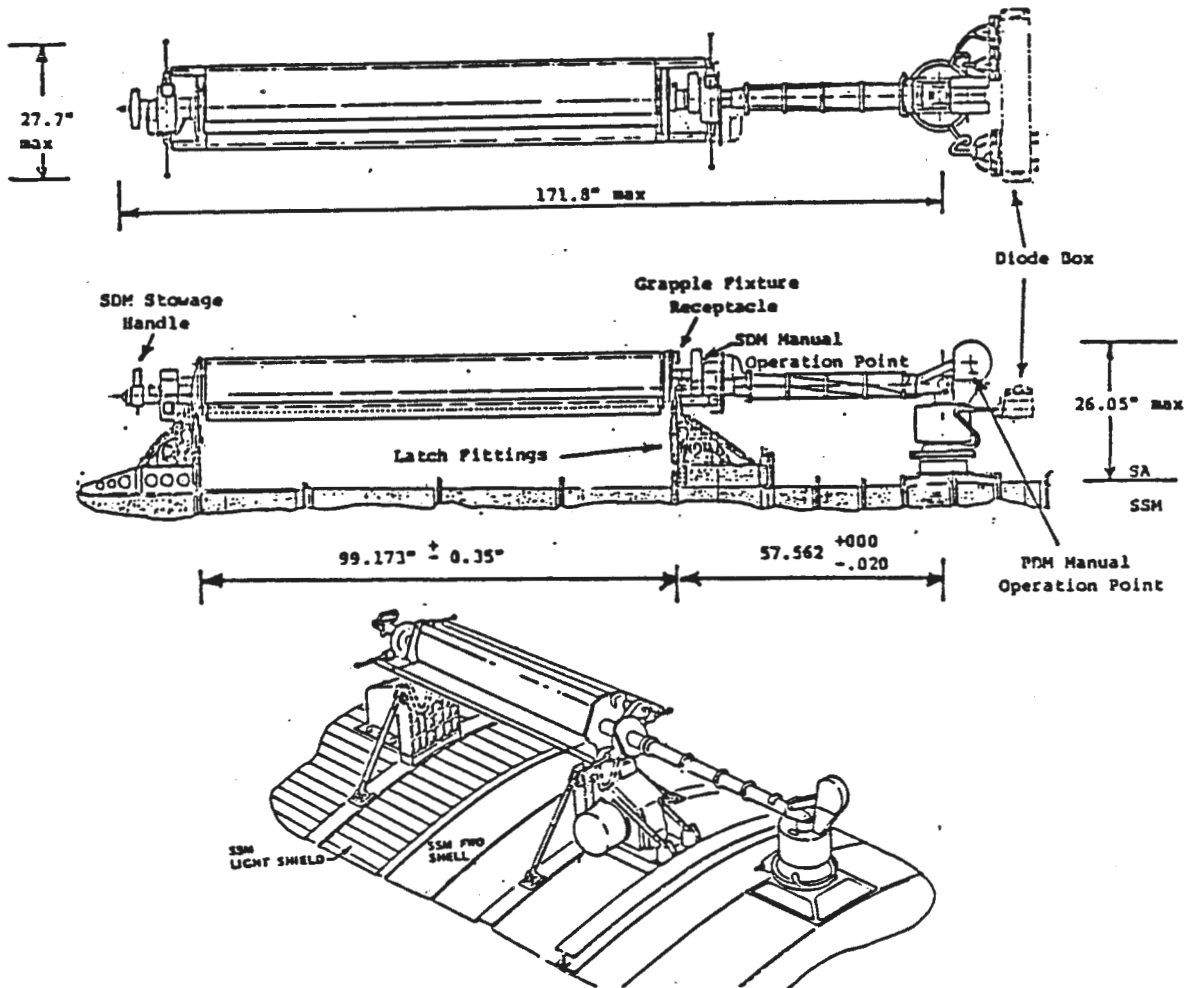

Figure 7-2 Solar Array in Stowed Configuration

The cushion roller and spreader bars are fabricated from carbon fiber and a special layup has been defined for these items. A center torque tube inside the spar tube carries the wire harness supplying power to the two SDM motors located on the outboard end of the spar tube.

7.1.3.2 Deployed Configuration

In the deployed configuration (Figure 7-3) the Solar Array Drive (SAD) provides rotational orientation about the deployment arm and blanket drum axes. The PDM provides a hinge and locking mechanism to rotate the array from its stowed to deployed position.

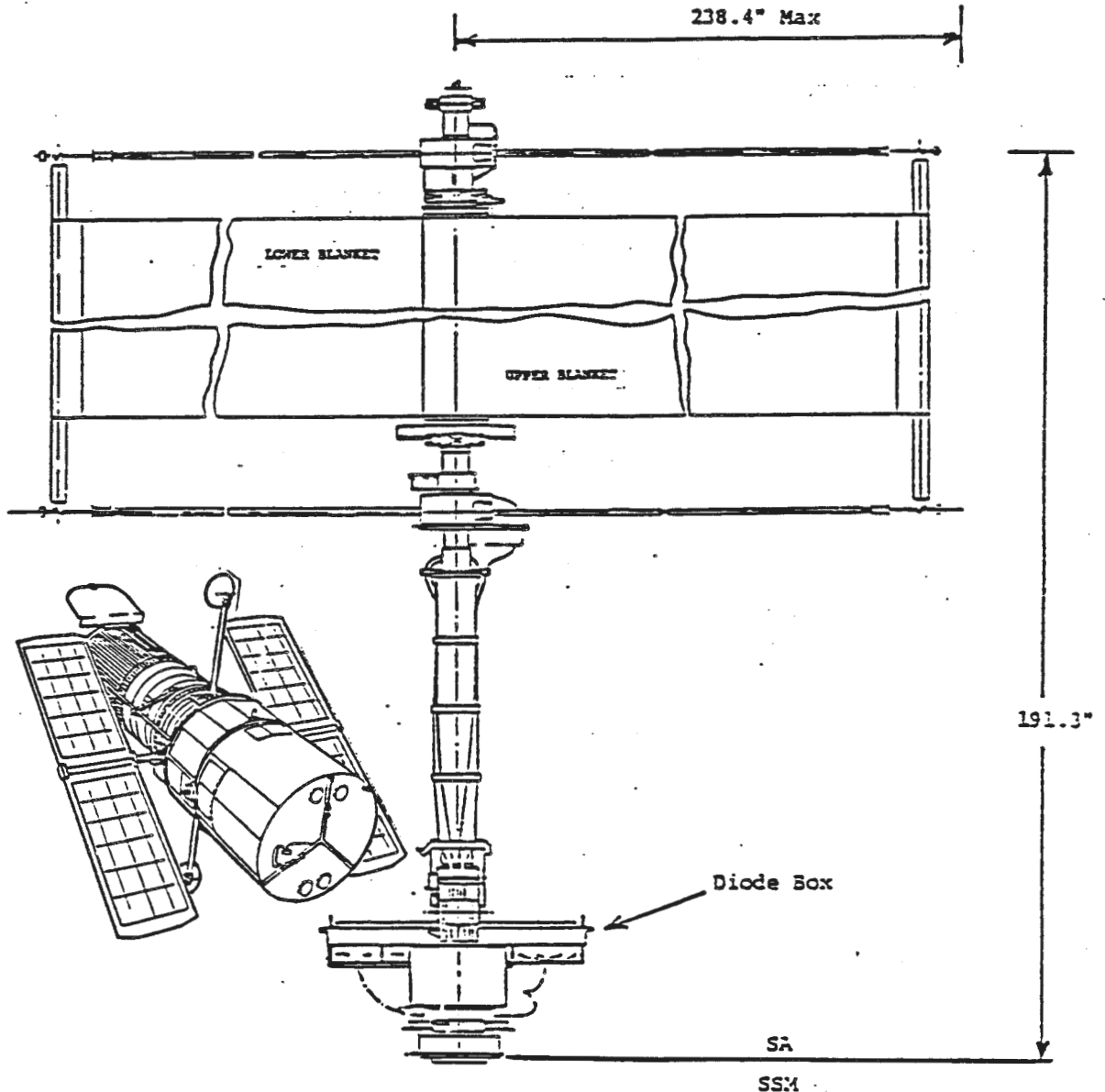

Figure 7-3 Solar Array in Deployed Configuration

A pair of bi-stem cassettes stretch the SA blanket between the spreader bar and drum. The tension in the blanket is maintained by tensator spring units between the central tube and the bi-stem cassette units, thus the bi-stem units are in compression.

The spreader bar combines a spring loaded roller and pulley wheel constraining the bi-stem and blanket. The use of this mechanism ensures constant tension at each side of the blanket.

7.2 SA Subsystems

7.2.1 Solar Cell Array

Each ST SA Solar Cell Blanket (i.e., one of four for the complete array) consists of five identical Solar Panel Assemblies (SPAs). Each SPA is built up of three solar cell strings, two of them with 106 cells in series and eight cells in parallel and one of them with 106 cells in series and seven cells in parallel. To protect the array from shadows caused by the ST, parallel connections are made by solar cell shunt diodes at intervals of 14, 15, or 16 cells in series.

The 2,438, 20.8x40.2 mm, 10 ohm-cm high efficiency cells of each SPA (cell thickness, 250 μ m cover slide 150 μ m CMX) are affixed to a 35 μ m glass fiber/25 μ m Kapton substrate which embodies distributed silver mesh rearside wiring. A 25 μ m Kapton layer covers the rearside wiring.

7.2.2 Primary Deployment Mechanism (PDM)

The PDM is responsible for deploying the array wing from its stowed position against the side of the SSM, to its deployed position perpendicular to the spacecraft body.

Two mechanisms are required for the SA system, one for each wing, and they are capable of independent or simultaneous operation.

The PDM consists of a housing which contains or supports the power drive and planetary gear system, the main boom trunnion and the boom.

The drive system consists of two parallel electrical stepper motors mounted upon a common shaft. These motors are independently powered, with one for normal operation and the second for redundancy. The boom, to which the SDM is attached, is rotated to the desired configuration by means of the motor driving through a planetary gear system with two parallel lever arm assemblies mounted to the output shaft at one end and the main boom at the other end. These lever arm assemblies are mounted on either side of PDM motor drive unit. Rotation of the output shaft of the gear system, therefore, translates through the two lever arms on each side of the PDM, rotating the boom through 90 deg about its main trunnion bearing. The length of the lever arms, however, are such as to allow the arm to be rotated up to three degrees beyond the nominal stowed position to ensure that the SA will be positioned within the reach envelope of the SSM latches for restowage. The PDM motors are driven with a nominal current of 360 mA \pm 10 percent. The nominal step frequency of the motors is 4 Hz. The Qualification Model has been successfully tested between 2 Hz and 6 Hz and at 310 mA.

The PDM also incorporates provision for manual operation by an astronaut in the event that the power system fails. To achieve this a hexagon fitting, capable of interfacing with a standard EVA ratchet wrench, is mounted on the side of the PDM motor

housing and acts, via a separate gear system, on the motor shaft. The rate of rotation is to be controlled by the astronaut.

Redundant (single pole) microswitches are incorporated to provide PDM deployed status information to the Deployment Control Electronics (DCE). These microswitches are positioned on the PDM structure and are actuated by the overcenter linkages when the deployed position is reached. As a result of this signal being received by the Drive Control Electronics, the motor power is automatically switched off.

The PDM is held in the deployed position by means of the lever arm center lines being aligned together in the overcenter position, providing the maximum possible mechanical advantage of the drive system. Positive locking into this position is achieved with the aid of two spring loaded ball detents added to the end of primary level arms. The SA wings are locked in the stowed position by the action of the SSM latches.

Thermistors mounted on the PDM, one on the motor stator housing and one on the main support bracket assembly adjacent to the main trunnion cage, provide in-orbit temperature information.

The electrical harness carrying the SA power and SDM motor power and instrumentation extending from the shaft of the SADM, passes around the PDM motor housing and main hinge and along the primary arm. The harness is attached to the arm, outside the multilayer thermal insulation by means of cable clamps placed equidistant along the arm. Four, nine-way Cannon connectors are mounted to the sides of the PDM main support bracket to provide the main and redundant motor power and instrumentation electrical connections to the PDM from the Drive Control Electronics.

7.2.3 Solar Array Drive (SAD) Adapter

The SAD adapter houses the SAD and attaches the SA wing to the SSM. It also incorporates the Extra Vehicular Activity (EVA) jettison plane to enable the complete wing to be jettisoned in orbit.

The SAD adapter consists of two concentric conical sections. The outboard section is bolted to the SA wing and is of smaller diameter than the inboard section which is bolted to the SSM. The outboard section fits inside the inboard section and is designed to accommodate the positional errors of ± 50 mm and ± 1 deg which may be imparted to the SA wing by the RMS during jettison.

The inboard section contains the supporting provisions for mounting the manacle clamp ring and the release mechanism. The outboard section of the SAD adapter includes the interface flange which mates with the SAD. The two halves of the adapter fit together with keyed centering flanges. The two sections are held together with a manacle clamp ring which can be opened for jettisoning the SA.

The two halves of the manacle ring are mounted on a pivot point on the inboard section of the adapter and mounted on the opposite side of the adapter is a securing mechanism, also on the inboard section. This securing mechanism consists of a nut and bolt device which pulls the clamp together thus forcing the two sections of the adapter together. The head at either end of this bolt has been designed to interface with the astronaut's ratchet wrench.

To release the manacle ring for jettison the astronaut interface requires approximately 22 turns. The initial torque required to open the clamp is approximately 3 Newton-meter (Nm) due to the tension in the clamp, and normal running torque during operation is 0.5-1.0 Nm. An indicator is provided to show the open/closed status of the clamp to the astronaut.

Provision has been made in the form of slots in the outboard section of the adapter for routing the wire harnesses through the adapter to the SSM. This wire harness installation is accomplished during assembly of the SAD to the adapter and has no effect on the jettisoning of the array.

7.2.4 Secondary Deployment Mechanism (SDM)

The SDM is responsible for deploying the blankets from the rolled up configuration once the PDM has deployed the wing perpendicular to the spacecraft axis.

Two mechanisms are required for the SA system, one for each wing, and they are capable of independent or simultaneous operation. Each mechanism is commandable, with manual override capability and is reversible in either the commanded or manual mode for restowage. It is also possible to only partially deploy or restow the solar cell blankets.

Each SDM consists essentially of the following:

- 0 Storage drum on which the flexible blanket is stored during launch
- 0 Drum Power Transfer Assembly along which power and data from the blanket is carried
- 0 Extendible Boom Actuator Assembly which extends and retracts the flexible blanket
- 0 Cushion and Cushion Roller - The cushion protects the flexible blankets during launch and the cushion roller stores the cushion after blanket deployment.
- 0 Tensator Motors which provide a constant reverse torque on the drum assembly and the cushion roller to ensure satisfactory roll-up and roll-out
- 0 Boom Length Compensator Mechanism ensures an even tension across the flexible blanket and accounts for any mismatch in the boom extension rates.

After Primary Deployment, the SDM is activated. The actuator motors drive the bi-stem booms out, which in turn draw the blanket off the drum. Tensator motors act against the drum rotation to ensure an even blanket roll-out. On full deployment, the booms remain locked by the high gearing in the actuator assemblies and the detent torque in the motor. As the array blanket is deployed, the Kapton cushion which protects the blanket in the stowed configuration, rolls onto the cushion take-up roller. This is achieved by means of another Tensator motor acting directly on the shaft of the cushion roller, completely independently of the main array storage drum.

The cable harness which transfers power and data from the blanket, passes along the drum and out toward the interface with the Primary Deployment Arm.

7.2.5 Solar Array Drive Mechanism (SADM)

The SADM orients the deployed SA wing toward the sun and is capable of rotation in either direction. Two mechanisms are required for the SA system, one for each wing, and each are capable of independent or simultaneous operation. The SADM shaft flange bolts directly to the PDM housing bracket while the SADM itself is contained within the SAD adapter by means of a bolted flange on the housing. The SADM is made up as a modular construction consisting of:

- 0 A central drive module containing the ball bearings/motor resolver assemblies and solenoid brake
- 0 An off-load device for protection of the bearings during launch
- 0 A Flexible Wire Harness (FWH) unit providing the power and signal transfer across the rotating joint between the SA and SSM
- 0 A manual locking device.

The drive module consists of two angular contact ball bearings, maintained under constant preload during in-orbit conditions by diaphragm. The bearings are liquid lubricated with Fomblin Z25. The drive torque is generated by one direct drive torque motor which is mounted together with a single speed plus multi-speed resolver on common structural rings. A second motor resolver assembly is provided for redundancy, but in an emergency both motors can be used simultaneously to overcome high resistance.

The angular position of the shaft is measured by the single-speed windings of the resolver. The multi speed windings of the resolver are used to produce the signal for commutation of the torque motor by the SADE. The solenoid brake consists of 12 brake pads equilly spaced around the circumference of the drive unit, attached to the housing and acting on a disk attached to the shaft. The function of the brake is to hold the SA wing orientation fixed in orbit against the FWH torque and in-orbit disturbances during normal operation. In this phase there is no power applied to the SADM. When power is applied to the motors to orient the SA, the solenoid brake is automatically powered off using electronic ramping circuitry to avoid mechanical disturbances.

In the launch configuration the SADM bearings are protected by an Off-Loaded Device (OLD) arranged at the outboard end of the SADM. Four latches engage radially into the V-groove on the circumference of the brake disk. The latches are kept in position by U-shaped levers which are hinged to a flange which in turn is mounted to the SADM housing. In the locked position the levers are overcentered and tied by a steel rope. Release is initiated by heating a memory alloy element which deflects and thereby moves away one of the levers. The steel rope and supporting springs then release the other levers and the latches. The steel rope is caught by springs at a sheet metal collar. A redundant memory alloy element is located at another lever. The locked and release status of the latches can be sensed by redundant microswitches wired in parallel.

In the event the OLD fails to be released by the memory alloy elements on deployment, a manual override capability has been included to enable release by an astronaut.

The electrical lines from the SA pass through the hollow shaft of the SADM (power and signal lines being separated by a screen) and into the flexible wire harness unit. The cables within this unit are not laced together in order to take advantage of the higher flexibility of the single cables which are allowed to twist and bend as the SADM rotates. The angular rotation of the FWH is limited by end stops to +170 deg but when the SADM is integrated into the SA the shaft is rotated with a 90 deg bias in order to satisfy the requirement for SA rotation of +260/-80 deg. The cables outboard of the SADM shaft are bundled and routed along the PDM and those inboard of the mechanism are bundled and connected to the diode box via EVA connectors, which are capable of being released in the event of an SA jettison.

Two manual locking devices are incorporated into the SADM as a means of fixing the rotation of the SA during in-orbit maintenance. The main reason for two devices is to ensure access to a brake for every possible orientation of the SA. In the stowed position however, both brakes are accessible and could be operated to provide added protection to the SADM bearings during reentry. The manual locking device consists of a lever system which acts on the shaft flange collar of the OLD. The device is actuated by rotation of a standard hexagon EVA interface through 180 deg which lifts the shaft flange against the fixed clamps of the OLD.

7.2.6 Electronic Control Assembly (ECA)

The ECA is responsible for the control and monitoring of all functions of the SA system except switching of the operational/survival heaters.

The ECA comprises three units, the Deployment Control Electronics (DCE) and the Solar Array Drive Electronics (SADE). The DCE is configured as one box and the SADE is configured as two identical boxes.

7.2.6.1 Deployment Control Electronics (DCE)

The DCE controls the primary and secondary deployment of the SA wings and monitors the characteristics related to the deployment mechanisms and SAs. Fully standby redundant equipment is used in which the two separated parts utilize no interconnections, except at inputs and outputs, in order to ensure that a failure in one part of the DCE does not propagate to the redundant part.

The DCE contains: the dc/dc Converters, Discrete Command Interfaces, Signal Conditioning and Controls, and Motor Select and Drive Stages.

7.2.6.2 Solar Array Drive Electronics (SADE)

The SADE can be considered as a number of discrete elements. The system redundancy requirements are satisfied by the provision of two separate SADE boxes. The major electronic elements and their purpose are:

- 0 Interface Electronics - Receives rotation angle commands, converts to a SA position and decodes the rotation direction. It also receives commands for the operation of the bearing OLD.
- 0 Shaping Function - Generates a rotation angle vs time sinusoidal shaping function in a time T which depends on the commanded angle.
- 0 Control System Compensation - Performs the transfer function derived from simulation work and stores the harness resistive torque value between the slewing maneuvers.
- 0 Motor Drive Stage - Generates motor currents, by amplification of the control input after multiplication with the decoded resolver multi-speed outputs.
- 0 Motor Power Ramping - Gradually increases/reduces the power to the motors to avoid sudden disturbances.
- 0 Brake Control - Generates a current time profile to disengage brake during slewing maneuvers.
- 0 Timing Control - Generates the necessary signals to comply with the control sequence.
- 0 OLD Control Circuit - Switches the OLD power bus to the OLD upon command and monitors status switch signals for the SA housekeeping data.
- 0 Oscillator, Divider, Sine Wave Converter - Generates the clock pulses for the various electronic functions and also the ac power for the resolver.
- 0 Temperature monitors of the SA drive mechanism are conditioned within the housekeeping circuits.

7.2.7 Diode Box Assembly (DBA)

The DBA is the unit containing the SA blocking diodes. There is a DBA for each SA wing, mounted on the forward facing part of the equipment bay section, and close to the SA SADMs. The DBA can be removed/replaced by an astronaut, the electrical interface being broken at the EVA Deutsch connectors. The cabling to the SA wing can be disconnected from the DBA at the EVA Connector. Cabling to the SA wings from the ECA, i.e., motor and instrumentation lines, is also routed via the DBA and can be disconnected at the EVA connectors.

The DBA contains 20 stud-mounted power diode. Each Solar Panel Assembly (SPA) circuit has two diodes connected in parallel, and mounted together on an aluminum heat sink. There are ten heat sinks per DBA. Isolation from the other heat sinks is by the use of an insulating plate onto which the heatsinks are bolted.

During normal operation, the heat radiation axis is directly away from the body of the SSM, and parallel to the SA PDM arm. However, in the contingency mode, when the sun can be up to 30 deg offset from the V1/V3 plane, the design of the DBA ensures that the diodes remain within their operating temperature limits.

During Maintenance Modes or Stowed Cold Cases, the temperature of the diode plates will fall to a very low value. To prevent the diodes from falling below their survival temperature limit of -65°C , heaters are fitted to each diode plate and the temperature controlled by redundant thermostats.

The EVA Connectors are grouped in two sets of four and two sets of two. Each group is mounted on a bracket, and the two halves of each group can be disconnected by the rotation of the locking screw. The removable connected brackets have keyhole slots for final fixing after electrical connection.

7.3 SA Equipment List

The complete SA system consists of two identical wings mounted on the +V2 and -V2 of the SSM respectively and an Electronic Control Assembly mounted within the SSM Body.

Each SA wing comprises the following subsystems:

- 0 SAD Adapter (containing wing jettison point)
- 0 Solar Array Drive Mechanism (containing bearing OLD)
- 0 Primary Deployment Mechanism
- 0 Secondary Deployment Mechanism
- 0 Solar Cell Blankets
- 0 Diode Box.

The Electronic Control Assembly is made up of:

- 0 Deployment Control Electronics (DCE)
- 0 Solar Array Drive Electronics, (in two separate boxes, SADE 1 main and SADE 2 redundant).

7.4 Interface Description

In the "Mechanical Interfaces" there are three mechanical attachment points between each SA wing and the SSM. The attachment point during all deployed modes of operation is via the SAD adapter. The SAD adapter is made of two halves which mate together at the EVA separation plane and the inboard half which is attached to the SSM. This interface is a simple flange bolted to the mounting of the SSM.

The additional attachment points to the SAD adapter are the SSM hold-down latches which restrain the SA wing in the stowed configuration. The latches are part of the SSM structure and restrain the wing at hold down points on either end of the SDM. The interface with the SDM is a fitting at the base of the cushion roller support structure to which the mating half of the latch assembly is bolted. The forward latch allows freedom of movement along the stowed axis of the wing to compensate for any mismatch between latches. The aft latch is designed to hold the wing rigidly in all three planes, and is the main load carrying point during the launch and landing phases.

The "Electrical Interface" connections are from SSM DMS to SA. The thermal control hardware is designed so that it does not prevent the mechanisms from performing efficiently their required functions.

8.0 MISSION OPERATIONS GROUND SYSTEM (MOGS)

The MOGS, shown in Figure 8-1, consists of the STOCC, ST SciI, and GSFC institutional elements which support the STOCC in its role of actively controlling the ST. These basic elements of the ground system are described in the following paragraphs.

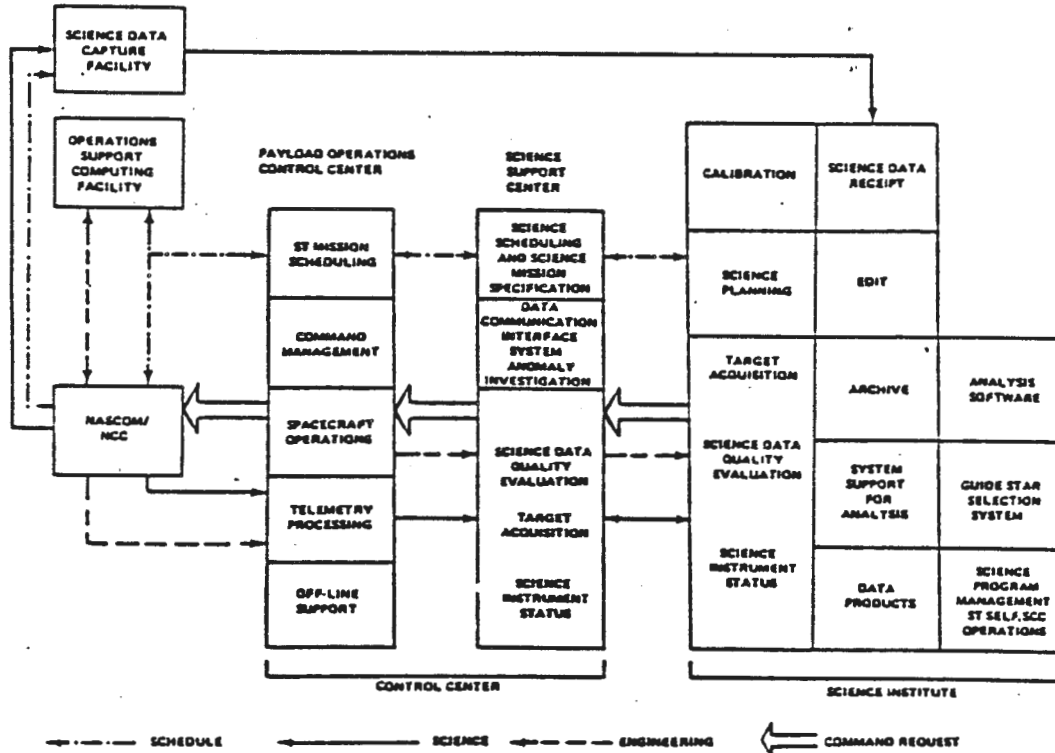

Figure 8-1 Mission Operations Ground System

8.1 ST Operations Control Center (STOCC)

The STOCC represents the primary and central controlling facility for performing ST mission operations. It is the facility that provides real time control, real time support for science operations, mission planning and scheduling, science scheduling, ST Engineering Data (ED) analysis and archiving, and a limited amount of Science Data (SD) processing and evaluation. The STOCC is divided into two distinct functional elements designated the POCC and SSC which are described in the following paragraphs.

8.1.1 Payload Operations Control Center (POCC)

The POCC represents the focal point for all mission operations including ST command and control, determination of operating constraints and restrictions, and ST health and status monitoring.

8.1.2 Science Support Center (SSC)

The SSC represents the primary interface between the ST Sci and the POCC, including daily science scheduling, Observer support, science real time operations, quick look data processing and display, and SD management. The SSC is the control point for science input and evaluation of SD.

8.1.3 Data Capture Facility (DCF)

The DCF represents the point where SD transmitted from the ST is captured. "Capture" means fully redundant on-line systems to preclude losing any data due to an equipment failure in the DCF. "Capture" includes data accountability and quality control functions performed to assure all data received is delivered to the ST Sci at the expected error rate. Specifically, SD are deblocked from the 4800-bit NASA Communications Network (NASCOM) block format, and any block errors are noted. The data are restored to a positive time sequence and downconverted, as required. The Pseudo-random Noise (PN) sequence is removed, if it was applied in the SI C&DH, the decoded data and the check bit segments are removed from the data stream. The data are assembled by packet, a data quality report added to each packet, and the packets separated by data source.

8.1.4 ST Science Institute (ST Sci)

The ST Sci conducts an integrated ST science program including the establishment of observing policy, selection and support of ST observers, detailed science planning, observation implementation, and data archiving, processing and analysis.

In addition to operations at its own location, the ST Sci provides scientists and other staff members to perform operations at the SSC, located at the STOCC. SSC personnel provide all the interface functions with the ST Sci necessary to implement detailed observing schedules, on-line console operations, monitoring of the ST Scientific Instruments (SIs), and management of the transfer of scientific data to the ST Sci's primary facility. The following paragraph describes the functions performed at the ST Sci's primary facility.

The ST Sci is responsible for science operations planning. This involves three distinct activities. First, the ST Sci develops the science program goals and objectives consistent with NASA policy, as well as ground rules for allocating observing time. Second, it conducts an observation/research solicitation process. Third, ST Sci personnel convert the results of this selection process into observation plans. This includes optimization of selected observing programs based on ST parameters. These plans are transferred to the SSC, where they are converted into science mission specifications.

Within the contractual arrangements regarding observation time guarantees made with the Principal Investigators (PIs), European Space Agency (ESA), and other participants in the development planning, the ST ScI has authority for allocating time, funds, and other ST ScI resources. The ST ScI staff competes for observing time with other astronomers on the basis of scientific merit.

The ST ScI controls all scientific operations of the SIs including calibration, data collection, and any real-time operations by ST ScI personnel or observers. The data processing operations at the ST ScI incorporate the following functions: (a) routine calibration (instrument signature removal); (b) processing for all observational data; (c) basic library of PI supplied and ST ScI supplied data reduction (analysis) routines; (d) access to all data processing software for approved researchers at the ST ScI; and (e) a standard line of data output formats.

The ST ScI provides research aids such as a library of computer programs, catalogs, mathematical algorithms, previously obtained data, and other applicable literature and documentation. In addition, the ST ScI also provides the operational expertise to assist the observers in optimizing their ST observational programs, and the technical expertise needed to produce unique computer programs to advise observers in the use of ST ScI post-observation data analysis capabilities.

The ST ScI accommodates astronomers who wish to utilize the facility for archival research.

The ST ScI also has a key role during the pre-operational phase. It interfaces with the development phase Instrument Development Teams (IDTs) in order to transfer knowledge of the instruments and to prepare for the transfer of operational responsibility during in-orbit verification. It participates in the activities of the science related working groups. It monitors and reports to NASA on the effectiveness of the verification activities, and actively participates in mission operations simulations and in-orbit verification.

During the operational phase, the ST ScI supports the development teams for new SIs in configuring their instrument. It also supports verification activities associated with refurbishment or modification of the ST in the same way as during the pre-operational phase.

8.2 Support Elements

This section describes the various institutional functions supporting the ST in performing its scientific objectives.

8.2.1 Spaceflight Tracking and Data Network (STDN)

The STDN provides a communications link between the ST and the STOCC to effect the transfer of commands and data between ground support elements and the ST.

8.2.1.1 Tracking and Data Relay Satellite System (TDRSS)

The TDRSS consists of two geostationary relay satellites 130 deg apart; one positioned at 41 deg West longitude (TDRS East), one positioned at 171 deg West longitude (TDRS West), and a ground terminal located at White Sands, New Mexico. The system also includes two spare satellites; one in orbit between the two operational satellites, and one available for rapid replacement launch. The positioning of the TDRSS creates a Zone Of Exclusion (ZOE) in which the ST is unable to communicate with the TDRSS. With an ST altitude of 560 km (302 NM) and an inclination of 28.5 deg, the ST expected communication coverage is limited to approximately 91 percent of the time. The TDRSS provides telecommunications services to multiple, simultaneous users utilizing real time, "bent pipe" data transfer techniques in forward and return link configurations. Operational usage of this system is the responsibility of the Networks Directorate at the GSFC and is administered through the Network Control Center (NCC). The NCC provides TDRSS scheduling, real-time configuration control, and performance monitoring services. Available TDRSS services utilized by the ST are described as follows:

Multiple-Access (MA) Service. The MA service provides a time-shared "forward link" service with a maximum bit rate of ten kbps and multiple, simultaneous "return link" services with a maximum bit rate of 50 kbps for each link. All MA users operate at the same frequency and polarization, and are discriminated by unique PN codes and phased-array antenna beam pointing.

The MA "forward link" service supports one user at a time per satellite. Each forward link service utilizes a single Radio Frequency (RF) link containing a command channel and a ranging channel.

The MA system "return link" service supports 19 simultaneous users. MA return link service, when scheduled, is dedicated to a user and provides support for the entire portion of the user's orbit which is visible to at least one of the two operational satellites. Each return link service utilizes a single RF link containing an in-phase channel and a quadrature-phase channel.

S-band Single-Access (SSA) Service. The SSA service provides time-shared "forward link" services with a maximum bit rate of 300 kbps and "return link" services with a maximum bit rate of 3 Mbps utilizing 3.8-m steerable high gain antennas. SSA users are discriminated by frequency, polarization, unique PN codes, and antenna beam pointing.

The SSA "forward link" service supports two users at a time per satellite. Each forward link service utilizes a single RF link containing a command channel and a ranging channel. SSA forward link services are time-shared and are scheduled on a priority basis.

The SSA "return link" service supports two users at a time per satellite. Each return link service utilizes a single RF link containing either a single telemetry data signal or two independent data signals. ST utilizes the single channel option. Return link services are time-shared and are scheduled on a priority basis.

Cross Support Service. The Cross Support Service provides SSA service to Multiple Access (MA) users which provides increased link performance to a degraded MA user or provides a MA user with the achievable data rates and link performance equivalent to SSA users.

Tracking Service. The MA service provides ST with tracking services utilizing a PN range and Doppler range rate system.

8.2.1.2 Ground Spaceflight Tracking and Data Network (GSTDN)

The GSTDN is a ground-based segment of the STDN consisting of a network of remote tracking stations. Operational usage of the GSTDN is the responsibility of the Networks Directorate at GSFC and is administered through the NCC which provides GSTDN scheduling, real time configuration control, and performance monitoring services. The GSTDN stations at Goldstone, California; Ororral, Australia, and Madrid, Spain, provide the capability for emergency recovery of ST ED during periods when ST attitude reference is lost and the High Gain Antennas (HGAs) cannot be pointed or the TDRSS is somehow rendered inoperative. The NASCOM provides multiple high-speed data and voice circuits for the transfer of data (command, tracking, and telemetry) between the GSTDN stations and the STOCC.

8.2.1.3 NASA Communications Network (NASCOM)

The NASCOM is a global communications network established and operated by the Networks Directorate at the GSFC to provide operational communications support to various NASA projects. This system provides leased, common-carrier communications services and NASCOM terminal system interfaces with user facilities. The capacity of the leased services is based on the projected growth of user data loads and is maintained at a level sufficient to support varying user requirements. The NASCOM selects the type of facilities to be utilized in providing the required services, based on communications needs, cost, availability, and performance. A mixture of domestic satellite and landline services is utilized to provide greater flexibility in meeting the requirements for reliability, diversity and potential growth. The NASCOM terminal systems time share these services between users.

The NASCOM terminal systems utilize time division multiplexing schemes to interleave blocks of data from multiple users on a common communications link. Each block of data is formatted into a prescribed 4800-bit block and contains only the data of a single user. The multiplexing scheme responds to a user's demand for transmission of data as a function of the user's data rate. As a result, high data rate users have a greater demand for access to the leased services than low data rate users and thus utilize a greater percentage of the capacity of the service. The NASCOM terminal system partitions the bit-contiguous user's data into groups of data bits and inserts a single group into the data field of a NASCOM block. Prior to transmission, each block is appended with a polynomial error detection code. At the receive end of the leased service, the blocks are demultiplexed, checked for transmission errors, and output to the user in either a blocked format or a restricted bit-contiguous data stream.

The NASCOM performs normal operational switching functions in direct response to, and in coordination with, the NASCOM schedule and the recipient of the data. The NASCOM monitors and tests the system to isolate faults. Corrective action on internal terminal system failures or common carrier outages are coordinated by the NASCOM.

8.2.1.4 Network Control Center (NCC)

The NCC provides a management function which allocates and regulates the use of STDN resources to satisfy the support requirements of all network users. The network control function is directly responsible for the continuous real time operations of the STDN including:

- 0 Responsibility for all operations control functions including voice interfaces for coordination, real time or emergency scheduling, data monitoring and accountability, fault isolation and troubleshooting, and testing and simulation involving network resources.

0 Responsibility for operations support in such areas as developing network support schedules, controlling changes in the STDN operational procedures documentation, processing requests for information, handling the STDN administrative matters, and analyzing network service performance.

The scheduling process forecasts network commitments three weeks in advance, thus permitting anticipation of events by the NCC, the GSTDN stations, and external users. A conflict-free weekly schedule is developed by the NCC to permit analysis of support requirements. A daily schedule is developed from the weekly schedule to control actual operations throughout the network. To develop these schedules, external users submit generic requests for a level of support which satisfies their needs. These requests are submitted at the beginning of the network support and need not be resubmitted unless support requirements change. In addition to establishing generic requests, external users request the addition of support events by defining the exact period of the event and mode of operation. The scheduling system operates on a non-priority basis allowing no explicit differentiation between requests being serviced.

8.2.2 Mission Planning Terminal (MPT)

The primary function of the MPT is to act as the interface for the POCC in obtaining STDN support from the NCC. The MPT provides POCC users with the capability to communicate with the Network Control Center Data System (NCCDS) in the TDRSS era. This function provides the POCC with the capability to convert their mission planning requirements into STDN service requirements, to communicate these requirements to the NCC, to view, confirm and modify the resultant STDN schedule, to receive and distribute schedules to the mission users, to alert the POCC of service impacts from NCC, and to exchange portions of the planning/scheduling data bases.

8.2.2.1 Interactive POCC Capability

The POCCs, via interactive Keyboard Cathode Ray Tubes (KCRTs), perform functions required to support the POCC-NCC planning/scheduling interface. The functions are designed with menu select or tabular input parameter control pages to assist the operators in entering the necessary information to interact with the planning tool. Manual inputs are minimized through the use of stored nominal information, such as the prototype event definitions. The manual entries are validated as much as possible.

8.2.2.2 NASCOM Interface

The interface with the NCCDS is via the NASCOM Message Switching System in 4800-bit NASCOM blocks. The MPT supports this exchange of information.

8.2.2.3 NCC Interface Protocol

The NCC interface protocol is defined in the POCC-NCC Interface Control Document.

8.2.2.4 Schedule Requests, Confirmations, and Receipt

The POCCs submit schedule requests for STDN service. The requests are in a generic or specific form. The requests make use of the predefined event prototypes or configuration codes that have been provided to the NCC. The POCCs, transform requirements into STDN support requirements containing the required information per the POCC-NCC Interface Control Document. The POCCs input a support requirement directly into the NCC without prior conflict analysis with other POCCs either as a specific or generic request.

Once the STDN advance schedule has been released, the POCCs are required to review the schedule and confirm all events that are desired in the schedule. These events are confirmed singly or collectively. The capability is provided for the operator to send a message(s) to the NCC scheduler to perform this function. Only events selected from generic requests require confirmation.

The NCC transmits schedules weekly, daily, and on an update basis. The capability is provided to receive the schedules and to provide them to the POCC and other users as a "POCC mailbox". Updates that are imminent have to be handled on a priority basis.

8.2.2.5 Prototype Event Definition

For each mission, prototype events are defined for the most common PASS support scenarios and stored in the MPT and NCCDS. Support requests for these type support events are not to contain the complete list of support items but refer to the prototype definition. The MPT is capable of creating and storing these events. The transmission of the prototype definitions are presently planned to be done external to the system interface via documentation.

8.2.2.6 Configuration Code Definition

For each mission configuration, codes are defined for the common services required of TDRSS and stored in the MPT and NCCDS. Support requests for events can be assembled by referring to the services Configuration Code Name and the times support is requested. Prototype events can also be constructed of configuration codes. The definitions of the configuration codes are presently planned to be transmitted to the NCC via the documentation interface.

8.2.2.7 Support Impact Message

A Support Impact Message is sent to a user if his support is impacted by a service level status change. The MPT is able to receive these messages. Impacts that are imminent are handled on a priority basis.

8.2.2.8 POCC Information Display

Information to the POCC is prepared for output on CRT displays and where specified, via hard copy. All information available is capable of being displayed via the CRTs. The POCCs have hard copies of schedules (weekly and daily), schedule updates, support impact messages, and status changes.

8.2.2.9 Data Base Exchange/Access

The MPT is able to transmit selected portions of a POCC data base to the NCCDS. The MPT is able to read and display for POCC planning use certain portions of the NCC data base.

The POCC is able to access and display planning information pertinent to scheduling/planning support requirements. This includes:

- (1) NCC-STDN status
- (2) Mission prototype definitions
- (3) Mission support requirements
- (4) Predicted coverage which includes geometric and predictable constraints such as:
 - (a) TDRSS/ST visibility (AOS-LOS)
 - (b) Sunlight entry/exit events
 - (c) RFI zone entry/exit events
 - (d) Solar interference (solar aspect angles with TDRS) events
 - (e) Apogee/perigee
 - (f) South Atlantic Anomaly (SAA)
 - (g) GSTDN AOS/LOS.

8.2.2.10 Other MPT Functions

The POCC-NCC Interface Control Document defines the types and the contents of the messages to be exchanged as well as the protocol. The MPT handles only the scheduling/planning and data base inquire/response messages. The POCC real time system handles the messages during spacecraft contacts.

8.2.3 Operations Support Computing Facility (OSCF)

The OSCF provides orbit related support to users. This support includes orbit analysis and planning, metric data collection and retrieval, orbit determination, trajectory generation, network calibration and validation, planning and scheduling aids generation, and acquisition data generation. OSCF provided support is separated into four phases: mission study, mission preparation, launch and early orbit, and mission operations.

In the "Mission Study" phase, the OSCF provides early analysis support to preliminary mission studies. These studies usually begin two or more years prior to the launch of the spacecraft. Typical orbit support studies include investigations to determine:

- o If/how definitive and predictive orbital accuracy requirements for a mission can be met
- o The major sources of errors in the orbit perturbations models
- o The quantity, quality, and frequency of metric data necessary to meet the mission accuracies
- o The resources needed to meet the mission requirements
- o The optimum operational procedures.

The "Mission Preparation" phase begins up to a year prior to launch. During this phase, the OSCF generates permission nominal orbit and acquisition data. Planning and scheduling aids to assist the NCC, POCC's, and experimenters in developing schedules for mission events are also generated as well as aids to support TDRS operations. New software or modifications to support mission unique requirements are developed in this phase along with new interfaces and procedural changes for the OSCF.

For the "Launch" phase, or in the case of the ST, Orbiter release and "Early Orbit" phase, the OSCF performs the real time function of receiving and processing Orbiter and ST tracking data to determine the mission orbit and generate acquisition data. This phase usually begins several hours prior to launch for testing and continues until a stable mission orbit has been achieved and confirmed. The OSCF also drives displays and transmits orbit and prediction data to various user functions for their initial operations and planning purposes.

After the operational orbit has been established, the OSCF moves into the "Mission Operations" phase. The following functions are a summary of the OSCF support.

8.2.3.1 Metric Data Processing

Metric tracking data, i.e., observations of a spacecraft by a tracking station, are received via the NASCOM and cataloged, stored, logged, preprocessed, and eventually archived. The data are used for the orbit determination function as well as for validation and calibration. Metric data validation and calibration are two activities to assess the quality of the data. Validation is a quick analysis of tracking data to identify gross anomalies. Calibration is to determine tracking data noise and bias values.

8.2.3.2 Orbit Determination

Using the metric data as input, the OSCF periodically derives updated orbit parameters. The orbit determination is performed to supply production orbits, definitive orbits, prediction orbits, and precision orbits to the NCC, POCC experimenters, and other users to meet the mission orbital data requirements. The OSCF also supports spacecraft maneuver activities by providing both real time and non-real time computational support. The non-real time support includes the production of ephemeris data predicting the spacecraft trajectory on either side of the maneuver. The real time support includes the generation of definitive orbital parameters immediately before and after the completion of a maneuver.

8.2.3.3 Acquisition Data Generation

Predictive ephemeris data are generated from the operational orbit solution. With the ephemeris data as input, acquisition data are generated routinely and periodically transmitted several days in advance to the STDN via the NCC and NASCOM.

8.2.3.4 Scheduling/Mission Planning Data Generation

This activity uses the predicted ephemeris data to generate orbit related sets of information which assist the NCC, POCCs and others in developing schedules and planning spacecraft activities. The types of data provided will include:

- (1) Orbital parameters, e.g., apogee/perigee, sunlight, time of ascending node.
- (2) STDN view periods, Acquisition Of Signal (AOS)/Loss Of Signal (LOS), range, angles.
- (3) Anomaly area entrance/exit times.
- (4) Magnetic field parameters.

It is estimated that the ST in-track orbital position will be predicted to the accuracies shown in Table 8-1. Cross-track accuracies will be better than in-track accuracies.

Table 8-1 ST In-Track Orbital Position Prediction Accuracy

| Time Predicted in Advance | ST In-track Orbital Position Accuracy |
|---------------------------|---------------------------------------|
| Days | km |
| 5-8 | 120 |
| 10-17 | 500 |
| 60-75 | thousands |

9.0 ST ORBITAL MAINTENANCE

The Space Telescope is the first NASA spacecraft designed to be maintained by astronauts (EVA crew) in space during Extravehicular Activity (EVA). The requirement for orbital maintenance has been a major consideration through the spacecraft design and development. It is planned that the ST will remain on-orbit during its 15 year projected life and will require periodic orbital maintenance.

The Space Transportation System (STS) used to deploy the ST at 320 NM altitude at an inclination angle of 28.5 deg will also deliver Space Support Equipment (SSE) to support on-orbit Maintenance Mission (MM) activities. During MM the ST may be reboosted if the orbit has decayed below an acceptable value. Return of the ST to earth can be accomplished during any MM as a contingency.

9.1 Maintenance Mission (MM)

During a MM, the Orbiter will rendezvous with the ST. With the aid of a television camera the Remote Manipulator System (RMS) will capture and berth the ST to the Maintenance Platform (MP) located near the Orbiter's cargo bay aft bulkhead.

9.1.1 Berthed Position

Once the ST is berthed to the MP, the V1 axis of the ST will be perpendicular to the centerline of the Orbiter cargo bay with the +V3 axis of the ST pointing along the positive X axis of the Orbiter. This berthing arrangement places the grapple fixture in a favorable RMS reach envelope and within a range of acceptable orientation. Electrical power to satisfy the berthed ST maintenance requirements will be provided by the Orbiter through an umbilical attached to the MP. The RMS will be released from the ST to be used in the performance of other maintenance operations.

9.1.2 Maintenance Position

After the release of the RMS, the MP is capable of rotating the ST ± 175 deg from the MP null position about its vertical axis (V1) to the desired maintenance operation position. The EVA crew, with the aid of the RMS, will remove replacement Orbital Replaceable Units (ORUs) from the ORU carrier, located at the mid-fuselage of the Orbiter cargo bay, and use the RMS as required to transfer the malfunctioned hardware elements. The ORU carrier will be used to return the removed ORUs to earth.

9.1.3 Reboost Position

During MM the ST may be reboosted to a higher orbit while attached to the MP and ORU carrier. The MP will pivot and/or tilt the ST to permit the ST to be lowered into and locked in a stabilized attitude. The Orbiter Reaction Control System (RCS) will reboost the ST/Orbiter to the desired altitude of 320 NM.

9.2 Space Support Equipment (SSE)

SSE consists of hardware items that are mounted/stowed on board, and transported by the STS to provide on-orbit Maintenance and Refurbishment (M&R) of the ST equipment and ORUs. The SSE will provide environmental protection for ORUs during prelaunch, launch, and orbit transfer. The SSE will aid the EVA crew in the removal, temporary (parking) storage, translation, installation, and activities associated with replacing failed or degraded ST ORUs. It will also provide storage space for the failed ORUs during return to earth in the Orbiter.

The SSE required for MM is comprised of two major assemblies shown in Figure 9-1, and other selected hardware elements described herein. One of the major elements is the Maintenance Platform (MP) located aft in the Orbiter cargo bay. This platform provides a docking interface with the ST as well as rotation and tilt capability for positioning the ST in order that maintenance operations can be efficiently performed. The other major element is the ORU Carrier which is located in the mid-bay of the Orbiter. This carrier provides environmental protection for ORUs.

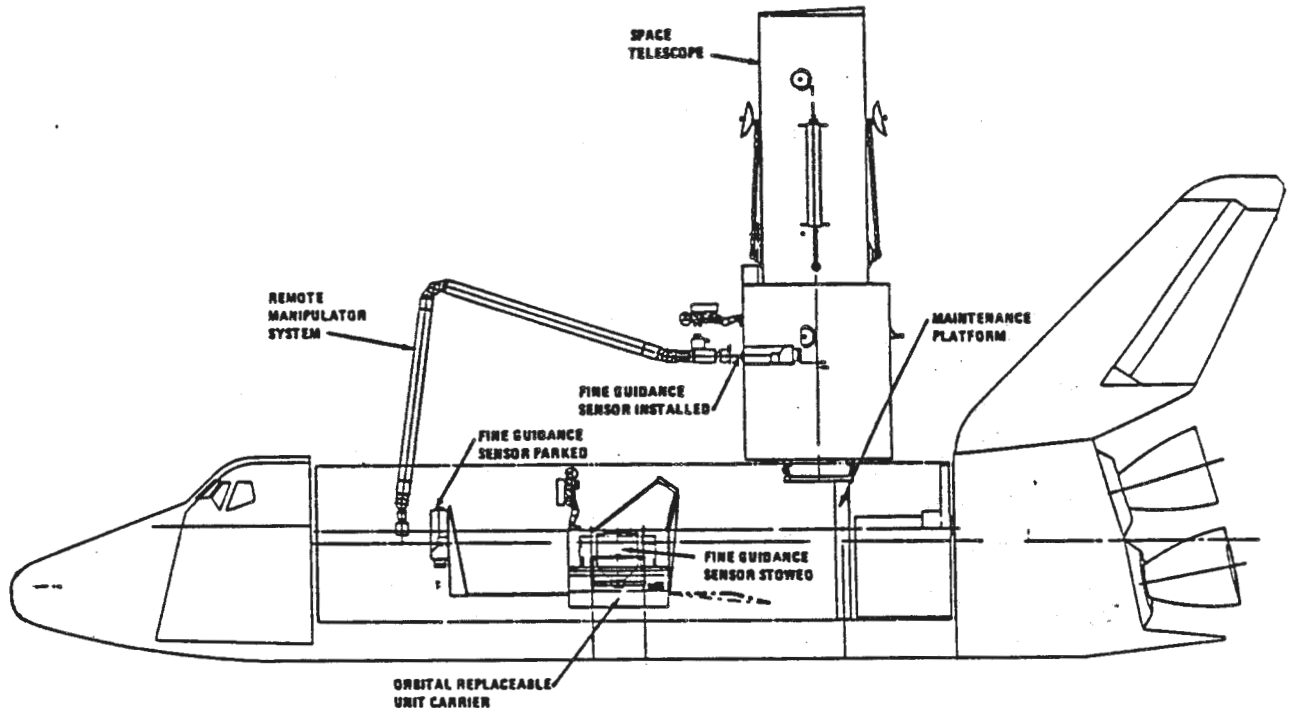

Figure 9-1 Maintenance Mission SSE Flight Configuration

9.2.1 Maintenance Platform (MP) Design Features

The MP (modified Flight Support System (FSS) A' cradle) is an article of SSE that mounts in the Orbiter payload bay aft bulkhead (Station 1179.13). This MP function is to act as a service platform for the ST during the scheduled on-orbit MM. The MP design is compatible with the use of the Orbiter RMS for berthing the ST to the MP and for separating the ST from the MP during ST deployment.

The structural design composite of the MP, shown on Figure 9-2, basically features three main structural elements. These elements are a cradle with an attached latch beam, a pivot arm, and a rotation platform.

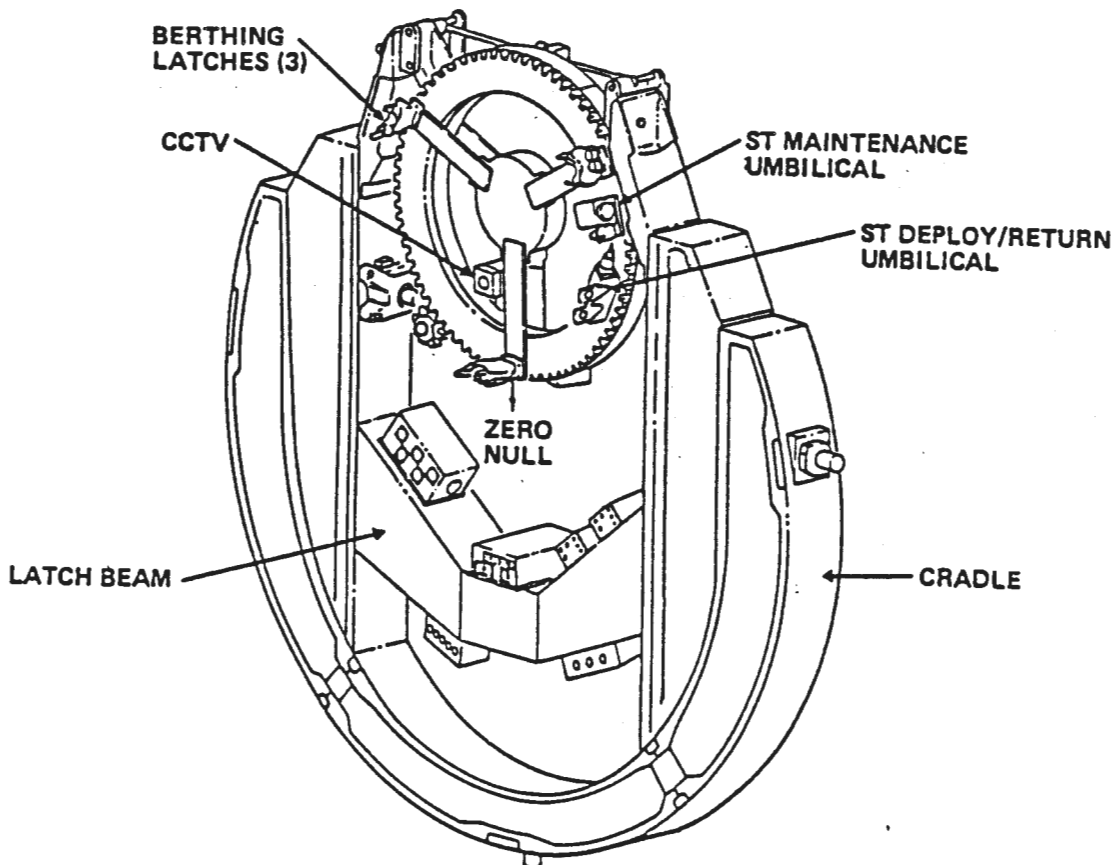

Figure 9-2 SSE Maintenance Platform (Modified FSS)

9.2.1.1 Cradle

The cradle is restrained in the Orbiter Z-X plane by two sill trunnions and in the Orbiter X-Y plane by one keel trunnion located at Orbiter Station 1179.13. The two sill trunnions are captured in nondeployable Payload Retention Latch Assemblies (PRLA) and the one keel trunnion is engaged into an Orbiter passive payload keel fitting. The cradle include crew aids and provides a latch beam support.

Latch Beam. The latch beam spans the cradle to provide a structure for mounting the avionics boxes.

Cradle Crew Aids. The cradle structural design include crew aids for maneuvering about the MP as an aid to a weightless environment during EVA. Handrails, tether rings, and standard crew foot restraints with mounting provisions are optimized as to the best location to fit the reach/work capabilities for operating manual overrides.

9.2.1.2 Pivot Arm

The pivot arm mechanically attaches to the cradle that supports the rotation platform. The pivot arm powered tilt system is capable of positioning the berthed ST at any intermediate position through the 90-deg sector to the final erect or berthing position. The pivot arm serves structurally to support electrical wire bundles required to transmit power and signal from the Orbiter to the rotation platform/ST.

9.2.1.3 Rotation Platform

The platform is a berthing/positioning system that contains the latches for berthing the ST and provides a pivot and rotation capability for positioning the ST during maintenance. A television camera mounted on the base ring of the rotation platform will aid the EVA crew in indexing the ST into its desired orientation for berthing the ST to the MP. The umbilical system is also mounted on the rotation platform of the MP. The MP umbilical interface plate and the attendant power cable is stowed or restrained in a retracted posture during the Orbiter launch and landing phases.

9.2.1.4 Umbilicals

Two independent umbilicals are required for the ST MM. Each umbilical satisfies the electrical power interface required between the berthed ST and the SSE MP during MM.

Maintenance (Primary) Umbilical. The primary umbilical is a remotely mated/demated motor driven umbilical. This umbilical is remotely mated from the Orbiter Aft Flight Deck (AFD) after the ST is docked and latched to the MP. The umbilical connector is remotely disconnected from the berthed ST aft bulkhead using a redundant technique and includes a manual disconnect EVA override capability.

Deploy/Return (Secondary) Umbilical. A secondary umbilical is required in the event that the primary umbilical is damaged in the docking operation. The ST deploy/return umbilical mechanism serves as the secondary umbilical. The umbilical connector is manually connected by EVA to the mating connector on the ST aft bulkhead. Redundant remote disconnect capability is provided with a manual EVA override as backup. This mechanism is two-failure tolerant for the demating operation to allow for release of the ST for emergency return of the Orbiter or contingency return of the ST.

9.2.2 ORU Carrier Design Features

The ORU carrier in Figure 9-3 is the second major element of the Orbiter SSE and is used to provide stowage and environmental protection for the replacement of ORUs on a scheduled ST MM. The ORU carrier enclosure contains a complement of assorted crew aids required to assist in the ORU maintenance changeout function. The carrier will serve as a changeout platform from which the EV crew can remove and replace various items from the ST and allow the replaced ORU to be returned to earth. The ORU carrier has the ability to be jettisoned should the mold line of the Orbiter be violated and/or during the contingency return of the ST to earth.

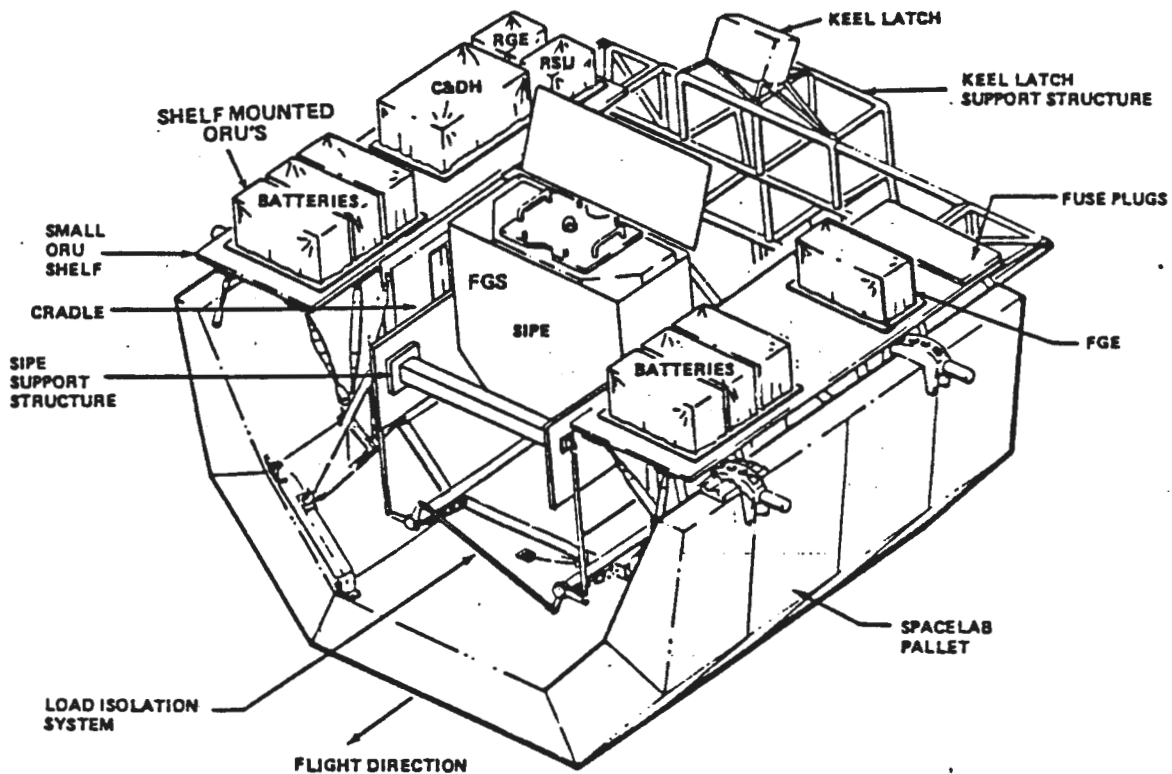

Figure 9-3 SSE ORU Carrier - 1 FGS Configuration

The basic SSE configuration consisting of the spacelab pallet, cradle, load isolation system, small ORU shelves, keel latch, load isolation and maintenance platform will be the same for all scientific payload complements. The Scientific Instrument Payload Enclosures (SIPES) and SIPE Support Structure (SSS) will be different for each of the large ORUs. The SA configuration will require deletion of the cradle and load isolation system.

9.2.2.1 ORU Payload Complements

The SSE has been sized to accommodate the ORU payload complements identified in Figure 9-4. It should be noted that these complements were used to size the ORU carrier and the flight configuration may be quite different.

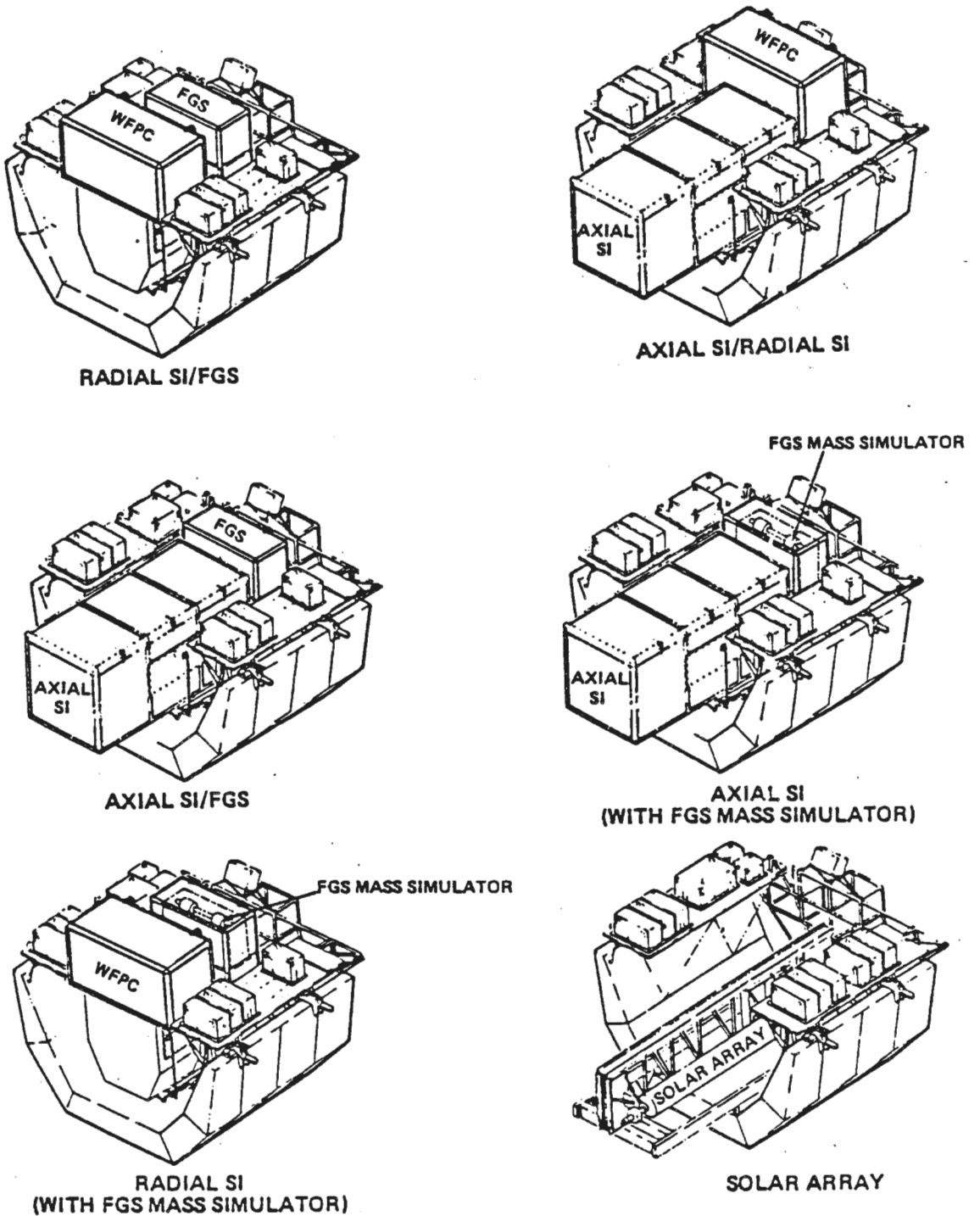

Figure 9-4 SSE Payload Complements

9.2.2.2 ORU Carrier/Orbiter Interface

The structural/mechanical interface to the Orbiter cargo bay is by means of an active keel trunnion (located at the primary Orbiter Station X 951) and four longeron trunnions (two located at Orbiter Stations X 892 and two located at X 951) actively engaged into remotely controlled payload retention latches. The operation for release or jettison of the ORU carrier does not require EVA. Scuff plates are also provided on the trunnion.

9.2.2.3 Carrier Crew Aids

The ORU carrier's doors, hatches, panels, and the external structure is designed to support and aid the crew in performing the ST maintenance function.

Tether ring attachments will enable the EVA crew to connect tethers and other transfer aids as necessary to control the translation of ORUs and capture SSE hardware.

Latches or similar devices used on the ORU carrier for doors, hatches, and panels are actuated by a direct push or pull by the crew member, rather than torques, side, or vertical forces.

A multiple positionable foot restraint contains a receptacle for mounting to flat, concave, and convex surfaces. The mounting stud is located both internally and externally to the ORU carrier to accommodate the EVA crew during the ST maintenance.

Handholds and handrails are mounted on the ORU carrier to accommodate the crew during the EVA.

9.3 ST Hardware Design Features

The ST hardware designed for on-orbit maintenance are the ORUs, and crew aids and tools that are designed into ST and required during ORU transport operations.

9.3.1 Orbital Replaceable Units (ORU)

The current ORUs and other candidate ORUs (CORUs) are listed in Table 9-1 showing the approximate size, weight, and location within the ST. These ORUs are designed to meet the following requirements: standard tool interfaces, safety requirements for sharp corners and edges, recognition and reduction of potential safety hazards, ORU interface access, handles and interfaces, tethers and interfaces, captive fastener designs, wing tab electrical connectors, tool-driven rack and panel connector configurations. All ORUs/CORUs listed are shelf mounted except the SIs, FGSS, and the SAs.

Table 9-1 Orbital Replaceable Units Listing

| Equipment | ORU/ CORU | Envelope in. | Wt. lb. | SSM Bay | OTA Bay | Location V1,V2,V3 | No./ Spare |
|------------|--------------|-----------------|------------|------------|------------|----------------------|---------------|
| FGE | ORU | 23x12x11 | 52 | - | D,F,G | | 3/1 |
| FGS (RB) | ORU | 66x46x22 | 504 | - | - | ±V2,+V3 | 3/1 |
| Battery | ORU | 24x10x14 | 137 | 2,3 | - | | 6/6 |
| MCU | CORU | 20x12x8 | 25 | 7 | - | | 1/1 |
| SI C&DH | ORU | 34x26x10 | 136 | 10 | - | | 1/1 |
| MAT | CORU | 10x4x2 | 12 | 5 | - | | 2/1 |
| PDU | CORU | 18x10x6 | 20 | 4 | - | | 4/1 |
| RWA | ORU | 21x25 Dia | 104 | 6,9 | - | | 4/3 |
| SA | ORU | 172x27x26 | 797 | - | - | ±V1,±V2 | 2/1 |
| HRS (AB-1) | ORU | 36x36x87 | 700 | - | - | +V2,+V3 | 1/0 |
| FOS (AB-2) | ORU | 36x36x87 | 700 | - | - | +V2,-V3 | 1/0 |
| FOC (AB-3) | ORU | 36x36x87 | 700 | - | - | -V2,-V3 | 1/0 |
| HSP (AB-4) | ORU | 36x36x87 | 700 | - | - | -V2,+V3 | 1/0 |
| DF-224 | ORU | 24x33x18 | 112 | 1 | - | | 1/1 |
| EP/TCE | CORU | 17x14x8 | 29 | - | H | | 1/0 |
| RSU | ORU | 12x10x9 | 24 | Shelf | - | | 3/3 |
| ECU | ORU | 11x9x9 | 17 | 10 | - | | 3/3 |
| SADE | CORU | 14x10x8 | 18 | 7 | - | | 2/1 |
| DIU | CORU | 15x16x7 | 25 | 3,7,10 | B | | 4/1 |
| Fuse Plug | ORU | 6x5 Dia | 0.4 | 4 (12) | F (2) | | 14/14 |
| TR | CORU | 13x10x7 | 21 | 5,8 | - | | 3/1 |
| Diode Box | ORU | 5x6x34 | 30 | FS | - | -V2,+V2 | 2/1 |
| WF/PC (RB) | ORU | 83x31x79 | 500 | - | - | -V3 | 1/1 |
| DMU | CORU | 26x30x7 | 83 | 1 | - | | 1/1 |
| OCE | CORU | 11x13x7 | 20 | - | C | | 1/2 |
| SAT | CORU | 10x8x2 | 10 | 5 | - | | 2/1 |

AB = Axial SI Bay

RB = Radial FGS & SI Bay

9.3.2 ST Mounted Crew Aids

ST mounted crew aids such as translation rails, handrails, handholds, and knobs are provided for hand and body control of the EVA crew at ST ORU locations. The translation rails are flattened aluminum tube sections permanently attached inside and outside the ST structure.

9.3.2.1 Handrails

Handrails (approximately 225 ft) are strategically placed on the surface of the ST to provide manual translation routes for crewmen during maintenance activities. The grasp surface of the translation rails, handholds, handles, and handrails have a non-slip surface with no sharp edges or protrusions that can be injurious to the crew member, Extravehicular Mobility Unit (EMU), or equipment. It should be pointed out that early simulations were conducted without the benefit of the Manipulator Foot Restraint (MFR) and therefore all crew aids provided the EVA crew with means of performing all tasks manually.

9.3.2.2 Foot Restraint Sockets

There are 31 foot restraint receptacles located on the external surface and in certain instances the interior surface, of the ST and with the aid of the portable foot restraint will hold the crewman's feet stationary.

9.3.2.3 Astronaut Control Panel (ACP)

The ACP duplicates the power control functions of the Orbiter standard switch panel. The ACP is located in the +V2 axis trunnion bay of the SSM ES. The EVA crew may use this panel to control the Orbiter electrical power to the ST.

9.4 Orbiter Stored Crew Aids and Tools

Crew aids are necessary for accomplishing the required ST on-orbit manual tasks associated with the EVA crew in removing old and new ORUs; temporarily holding old ORUs; and installing new ORUs. Crew aids will permit the crew to maneuver about the ST, the MP, and the ORU Carrier and serve as an aid to working in a weightless environment.

9.4.1 Portable Handholds

Removable handholds, called portable handholds, are provided to give crewmen the means of handling devices that are not built with permanent handholds. The radial SI and FGS each have a portable handhold plate which is installed during handling activities and removed when the instrument is installed before operation. The ratchet wrench will be the only tool considered for use with the transfer aids, if required, for set-up, tear down, utilization, and/or adjustment. Handholds for CORUs may need to be developed.

9.4.2 Foot Restraint

To perform any of the EVA tasks on a maintenance operation the EVA crew will utilize a Portable Foot Restraint (PFR). This Orbiter stored crew aid device plugs into any of the 31 receptacles located on the ST.

9.4.3 Personnel and Equipment Tethers

The personnel and equipment tethers will be standardized to those used on the ST. The tether fittings will interface with the standard Apollo Equipment Tether Hook and the Apollo Waist Tether Hook used to retain the ORUs and EVA tools.

9.4.4 Ratchet Wrench

This tool is necessary to accomplish the required on-orbit normal tasks. The handhold plate assembly has two parallel crew handholds for guidance stability and a tether ring attachment. The handhold plate assembly is capable of interfacing with the payload interface mechanism on the Manipulator Foot Restraint (MFR) for transfer operations during ST maintenance. The plate assembly will interface with the radial SI cover and the FGS. This wrench is flight qualified and has five extensions from 2 to 24 in. in length. An existing JSC power handtool is available for operations which involve numerous revolutions of a fastener or a manual deployment/retraction mechanism. This tool prevents crew fatigue that would result from the use of a manual tool for these EVA tasks.

APPENDIX A

SUMMARY of WEIGHTS and MASS PROPERTIES

A1.0 INTRODUCTION

A Mass Properties Status Report, ST/SE-04, is published two weeks after each Quarterly Review to provide a review of the current mass properties status with respect to established objectives and limits, to assess the changes that have occurred since the last report (Ref. 1), to identify pending and potential changes, and areas of concern. One should reference the most current ST/SE-04 document for updated status of the summary of the weights and mass properties.

Section A1.0 provides the ST Weight Status. The current ST weight is 23,727 lb., maximum projected launch weight for the ST is 24,973 lb (margin of +1,773 lb). Table A1-1, Specification Weight Status, provides a comparison of the current configuration weights with the corresponding specification and CEI limit values and shows a build up of the total weights for both the launch and maintenance missions. Table A1-2, presents Orbital Payload Control Weights; Table A1-3 lists the ST equipment; and Table A1-4 presents a typical ORU list.

Section A2.0 provides summary weight statements for the SSM, OTA, and AS at the subsystem level, plus the weights of the SIs and SI C&DH. Values in Table A2.0 may vary by up to one pound from data in Table A1-1 due to decimal round-off.

Section A3.0 contains detailed component level weight statements for each element of the ST, and an estimate of the maturity of the weight data, e.g., estimated, calculated or actual.

Section A4.0 contains the mass properties for the ST in both the stowed and deployed configurations, and for the OTA/SI/FHST/RSU assembly suspended at STA 240, and transformation matrices required by PIP.

Section A5.0 presents the Critical Mass Properties Summary.

Section A6.0 presents Pending and Potential Changes.

Mass properties presented in this document reflect the current ST design as of 30 January 1985 (as presented at the February 1985 ST QUARTERLY REVIEW). These data will not be updated on future revisions of the ST Systems Description Handbook. Reference should be made to the latest QUARTERLY REVIEW.

OTA mass properties reflect Perkin-Elmer's Quarterly Mass Properties Report for February 1985. Total current weight is 9,033 lb (including 8 lb contingency, 0.1 percent) which is 605 lb under CEI weight (9,638 lb). Maximum projected launch weight for the OTA is 9,688 lb.

Total current weight for the SIs and SI C&DH is 3,365 lb, 72 lb under CEI weight (3,437 lb). The total weight of the SIs and SI C&DH includes 0 lb of contingency. Maximum projected launch weight for the SIs is 3,424 lb.

Total Solar Array current weight, including BAe (692 lb) equipment is 735 lb; 62 lb under CEI weight (797 lb). Maximum projected launch weight for the SA is 746 lb.

Total SSM current weight is 10,594 lb (including contingency of 69 lb, 0.7 percent of basic weight), which is 527 lb under CEI weight (11,121 lb). Maximum projected launch weight for the SSM is 11,090 lb.

Table 1-1 SPECIFICATION WEIGHT STATUS

| <u>Description</u> | <u>Original CEI Weight (lb.)</u> | <u>GFE and Spec. Wt. Changes (lb.)</u> | <u>Approved Revised CEI Weight (lb.)</u> | <u>Current Weight (lb.)</u> | <u>Current Margin (lb.)</u> |
|--|----------------------------------|--|--|-----------------------------|-----------------------------|
| Support Systems Module | 9,200 | +1,921 | 11,121 | 10,594 | +527 |
| Optical Telescope Assembly | 6,300 | +3,338 | 9,638 | 9,033 | +605 |
| Axial SI | 2,800 | -92 | 2,708 | 2,660 | +48 |
| Radial SI | 500 | +100 | 600 | 569 | +31 |
| SI C&DH | 75 | +62 | 137 | 136 | +1 |
| Solar Array | 770 | +27 | 797 | 735 | +62 |
| <u>Total</u> | 19,645 | 5,345 | 25,001 | 23,727 | +1,274 |
| NASA Reserve - ST | | | 499 | 0 | +499 |
| ST LIMIT WEIGHT (1) | | | 25,500 | 23,727 | +1,773 |
| <u>Launch Mission</u> | | | | | |
| Space Telescope | | | 25,500 | 23,727 | +1,773 |
| Space Support Equipment (3) | 1,800 | - | 1,800 | 300 | +1,500 |
| NASA Reserve - Mission | | | 400 | 0 | +400 |
| MISSION LIMIT WEIGHT (2) | | | 27,700 | 24,027 | +3,673 |
| <u>Maintenance Mission</u> | | | | | |
| Space Support Equipment | TBD | - | TBD | TBD | |
| Spares - ORU's (4) | TBD | - | TBD | 2,605 | |
| TOTAL ST PROVIDED EQUIPMENT - MAINTENANCE | | | TBD | TBD | |

(1) STS/ST payload Integration Plan, JSC 14009 Rev. A, May 1981 and change No. 2, 18 February 1982.

(2) Space Telescope Level II IRD, Space Telescope to Shuttle Orbiter Interface STR-04B, 14 September 1979.

(3) See Table 1-4.

(4) See Table 1-5.

Table 1-3
ORBITER PAYLOAD CONTROL WEIGHTS⁽¹⁾

| | <u>Deployment Mission (lb.)</u> | <u>Maintenance Mission (lb.)</u> | <u>Return Mission (lb.)</u> ⁽²⁾ |
|--|-------------------------------------|--------------------------------------|--|
| Space Telescope | 25,500 ⁽³⁾ | N/A | 25,500 ⁽⁴⁾ |
| ST Space Support Equipment | 2,200 | TBD | 2,200 |
| STS Integration Hardware ⁽⁵⁾ | 1,720 | 1,720 | 1,720 |
| Mission Kit ⁽⁶⁾ | 28,615 | 30,410 | 16,250 |

NOTES:

- 1) The table and notes (2-5) are based on page 10 of the Payload Integration Plan (PIP), JSC14009, Rev. A, May 1981; Change No. 2, 18 February 1982. Additionally, the ST is not responsible for C.G.'s of orbiter provided hardware; the STPO will deliver ST hardware within the limits specified in ICD-19001 (cargo is now defined as ST provided hardware only).
- 2) The down weight for this mission will be 34000 lb. assuming an OMS kit return weight of 4,600 lb.
- 3) The ST will be deployed and will not be onboard during return.
- 4) The ST will not be onboard at launch but will be retrieved and returned to ground.
- 5) This line includes the STS payload chargeable items (Standard Mixed Cargo Harness (SMCH) and bridge/keel fittings).
- 6) This line includes the OMS kit, fourth EPS tank set, the nitrogen tank, and consumables.

Table 1-4
SPACE SUPPORT EQUIPMENT (ASE)*

| <u>Description</u> | <u>A</u> | Current Weight (lb.) |
|--|----------|----------------------|
| | | <u>Total</u> |
| Structure-Equipment | E | 118 |
| Electrical Cabling | E | 21.6 |
| Umbilical Disconnect Mechanism | C | 27.6 |
| I/F Power Box | E | 37.8 |
| Foot Restraint (2) | E | 59 |
| Ratchet Wrench (2) | S | 16.4 |
| (includes 2 each of Ratchet, Extension, Socket) | | |
| Torque Limiter (6) | S | 2.4 |
| Tool Case | E | 12.0 |
| Appendage Jettison Handle | E | 4.7 |
| TOTAL | | 299.5 |

*current values based on ASE C-WEAR data package.

Table 1-5
FIRST PLANNED MAINTENANCE MISSION
- PRELIMINARY -

| <u>Equipment (ORU)</u> | <u>Quantity</u> | <u>Weight</u> | <u>Weight⁽¹⁾ Class</u> |
|-----------------------------------|-----------------|---------------|---------------------------------------|
| Battery ORU | 6 | 807.8 | PA |
| Rate Sensor Unit | 1 | 23.9 | PA |
| Rate Gyro Electronic Control Unit | 1 | <u>17.3</u> | PA |
| Total SSM Equipment | | 849.0 | |
| Radial FGS/OCS Modules | 3 | 1479.2 | E/CR/A |
| Fine Guidance Electr./FGS SERVO | 3 | 134.6 | S/A |
| Total OTA Equipment | | <u>1613.8</u> | |
| SI C&DH | | <u>135.9</u> | A |
| | | 135.9 | |
| Total Equipment Changeout (2) | | 2,598.7 | |

NOTE: (1) See notes on page 4-1 for definition of weight classes.

(2) This represents the heaviest option for ST maintenance mission pallet configuration.

2.0 SUMMARY WEIGHT STATEMENT

LMSC/D974197B
31 May 1985

| Description | Wt-Last Report (lb.) | Current-Wt Incl/ Cont (.b.) | Changes-Last to Current (lb.) | Weight Class | | | Note. No. (Refer to Section 3.0) |
|-----------------------------------|----------------------|-----------------------------|-------------------------------|--------------|----------|---------|----------------------------------|
| | | | | Est (%) | Calc (%) | Act (%) | |
| Structure | 5263.8 | 5292.5 | +28.7 | 1 | 23 | 75 | 1 |
| Mechanisms | 541.6 | 541.8 | +0.2 | 11 | 67 | 15 | 2 |
| Thermal Control | 618.3 | 603.4 | -14.9 | 5 | 56 | 39 | 3 |
| Electrical Power | 2055.7 | 2043.8 | -11.9 | 4 | 6 | 90 | 4 |
| Communications/Instrumentation | 234.9 | 236.9 | +2.0 | 11 | 33 | 55 | 5 |
| Data Management | 380.5 | 375.7 | -4.8 | 1 | - | 99 | 6 |
| Pointing Control | 1151.3 | 1153.7 | +2.4 | - | 12 | 88 | 7 |
| Crew Systems | 373.4 | 364.1 | -9.3 | 3 | 69 | 28 | 8 |
| Manufacturing Variation | -18.0 | -18.0 | - | - | - | 100 | 8 |
| Support Systems Module | 10601.5 | 10593.9 | -7.6 | 3 | 24 | 72 | 1 |
| Optical Telescope Assembly | 9116.7 | 9033.4 | -83.3 | - | 6 | 94 | 10 |
| Solar Cell Array | 164.5 | 164.5 | - | - | - | - | - |
| SSM Provided Equipment | 42.5 | 42.5 | - | - | - | - | - |
| Deployment Mechanisms/Drives | 460.6 | 460.6 | - | - | - | - | - |
| Electronic Control/Miscellaneous | 65.1 | 67.8 | +2.7 | - | - | - | - |
| Solar Array | 732.7 | 735.4 | +2.7 | - | 4 | 96 | 11 |
| Faint Object Camera | 706.0 | 706.0 | - | - | - | 100 | - |
| Faint Object Spectrograph | 682.1 | 682.1 | - | - | - | 100 | - |
| High Resolution Spectrograph | 684.7 | 684.7 | - | - | - | 100 | - |
| High Speed Photometer | 586.8 | 586.8 | - | - | - | 100 | - |
| Wide Field & Planetary Camera | 568.6 | 568.6 | - | - | - | 100 | - |
| Scientific Instruments C&DH | 135.9 | 135.9 | - | - | - | 100 | - |
| Scientific Instruments Complement | 3364.1 | 3364.1 | - | - | - | - | - |
| Total ST on Orbit. | 23815.0 | 23726.8 | -88.2 | 1 | 13 | 86 | - |

4.0 DETAIL WEIGHT STATEMENT

4.1 Support Systems Module (SSM)

| CODE | DESCRIPTION | NO. REQ'D | CURRENT WEIGHT (LB) | WEIGHT CLASS* |
|---------------|----------------------------|-----------|---------------------|---------------|
| Structure | | | | |
| Aperture Door | | | | |
| A105 | Honeycomb Door | 1 | 79.0 | A |
| A115 | Sunshield | 1 | 6.6 | PR/CR |
| A120 | Fittings | AR | 4.0 | E/PR/CR |
| A121 | Attach Parts | AR | 1.1 | PR |
| A135 | Hinge Mounts on AP Door | AR | 6.9 | CR |
| | Round off | | +0.1 | |
| | Total Aperture Door | | 97.7 | |
| Light Shield | | | | |
| A136 | Hinge Mnts on LS | AR | 12.1 | A |
| A204 | Ring-I/F Sta. 458.5 | 1 | 40.7 | A |
| A205 | Rings | 8 | 47.0 | A |
| A207 | Ring-S/A sta. 476.7 | 1 | 16.2 | A |
| A208 | Ring-AP. Door sta. 608.5 | 1 | 38.0 | A |
| A210 | Baffles | 10 | 29.2 | A |
| A215 | Skin Assys. | AR | 180.1 | A |
| A220 | Equipment Supports | AR | 10.3 | A |
| A229 | LGA Mount | 1 | 1.5 | A |
| A240 | Scuff Plate Instl. | 2 | 56.2 | A |
| A250 | Crew Aid Supt. Struct. | AR | 37.6 | A |
| A709 | Supt. Structure - S/A | AR | 5.9 | A |
| A729 | SA Latch Diagonal Support | 4 | 10.8 | CR |
| A825 | HGA Latch Mount Provisions | 2 | 11.3 | A |
| A290 | Attach parts | AR | 20.4 | A/CR/E |
| | Round Off | | -0.2 | |
| | Total Light Shield | | 517.1 | |
| Forward Shell | | | | |
| A304 | Ring-I/F Sta. 299.25 | 1 | 32.5 | A |

- * E - Estimated
- CL - Layout Calculation or Equivalent
- PR - Pre-release Drawing Calc or Equivalent
- CR - Released Drawing Calc or Equivalent
- PA - Actual Weight of Item Used on Other Program, or Qual/Test Unit
- A - Actual Weight
- S - Maximum Specification Weight

| CODE | DESCRIPTION | NO REQ'D | CURRENT WEIGHT (LB) | WEIGHT CLASS |
|------|-----------------------------|----------|---------------------|--------------|
| A305 | Rings | 7 | 63.4 | A |
| A306 | Ring-Trunnion Sta. 358.0 | 1 | 120.2 | A |
| A307 | Ring-S/A Sta. 377.6 | 1 | 16.1 | A |
| A308 | Ring-I/F Sta. 458.5 | 1 | 21.4 | A |
| A315 | Skin Assys. | AR | 396.8 | A |
| A320 | Mag. Torquer Supports | AR | 73.3 | PR/CR/A |
| A330 | Crew Aid Supt. Struct. | AR | 56.5 | A |
| A350 | Grapple Fixture - GFE | 2 | 50.5 | S |
| A351 | Grpl. Fix. Supt. Struct. | AR | 50.5 | E/CR/A |
| A355 | Target-Keel Camera | 1 | 1.8 | CR |
| A360 | Trunnion Assy-Sta. 358.0 | 1 | 88.2 | CR/A |
| A390 | Attach Parts | AR | 26.0 | CR/A |
| A710 | Supt. Str.-S/A Latch | AR | 35.3 | CR/A |
| A711 | SAD Supt. Str. | 2 | 16.1 | A |
| A800 | Supt. Str.-HGA | AR | 17.8 | A |
| A820 | HGA Booms | 2 | 19.0 | A |
| | Total Forward Shell | | 1085.4 | |
| | OTA Equipment Section | | | |
| A000 | Structure | 1 | 287.2 | A |
| | Total OTA Equipment Section | | 287.2 | |
| | SSM Equipment Section | | | |
| A405 | Aft Bulkhead | 1 | 352.5 | A/CR |
| A410 | Fwd Bulkhead | 1 | 271.9 | A |
| | Bulkhead Total | | 624.4 | |
| A415 | Rib 0 Degree | 1 | 57.6 | A |
| A416 | Rib 30 Degree | 1 | 19.2 | A/CR |
| A417 | Rib 60 Degree | 1 | 16.7 | A/CR |
| A418 | Rib 90 Degree | 1 | 22.4 | A |
| A419 | Rib -V2 Degree | 1 | 62.9 | A |
| A420 | Rib 120 Degree | 1 | 52.6 | A |
| A421 | Rib 150 Degree | 1 | 28.2 | A |
| A422 | Rib 180 Degree | 1 | 21.0 | A |
| A423 | Rib 210 Degree | 1 | 22.4 | A/CR |
| A424 | Rib 240 Degree | 1 | 52.4 | A/CR |
| A425 | Rib +V2 Degree | 1 | 62.9 | A |
| A426 | Rib 270 Degree | 1 | 22.4 | A |
| A427 | Rib 300 Degree | 1 | 17.4 | A/CR |
| A428 | Rib 330 Degree | 1 | 21.8 | A/CR |
| | Rib Total | | 479.9 | |

| CODE | DESCRIPTION | NO. REQ'D | CURRENT WEIGHT (LB) | WEIGHT CLASS |
|-------------------------------------|----------------------------|-----------|---------------------|--------------|
| A440 | RWA Supt. Structure | AR | 109.1 | A/CR/PR |
| A445 | Door Panels | 10 | 269.6 | A/CR |
| A447 | Door Stops | 63 | 6.5 | A |
| A450 | Inner Skin | 1 | 149.5 | A |
| A455 | Trunnion Bay Skin | 2 | 43.7 | CR/A |
| A460 | Orbiter Att. Figs. | 3 | 108.2 | E/A |
| A465 | Inner Skin Rings | 5 | 104.0 | A |
| A470 | Crew Aid Support Str. | AR | 31.3 | PR/CR/A |
| A475 | Scuff Plates | 2 | 16.1 | PR |
| A480 | ORU Structure | AR | 5.6 | CR/A |
| A485 | Equipment Supports | AR | 53.5 | PR/CR/A |
| A490 | Attach Parts | AR | 112.2 | PR/CR/A |
| | Round Off | | -0.3 | |
| Total SSM Equipment Section | | | 2113.3 | |
| A505 | Skin-Milled | 1 | 115.3 | CR |
| A506 | Skin-Monocoque | 1 | 61.2 | CR |
| A508 | FGS Doors | 6 | 94.0 | CR/A |
| A509 | Axial SI Doors | 4 | 170.0 | CR/PA |
| A510 | FHST Door | 2 | 88.3 | CR |
| A515 | Rings | 9 | 118.0 | CR |
| A516 | Ring I/F Sta 238.0 | 1 | 29.9 | CR |
| A520 | Longerons | AR | 57.9 | CR |
| A521 | Brackets/Gussets | AR | 11.4 | CR |
| A523 | Aft Bulkhead Misc. | AR | 30.0 | PR/CR |
| A525 | Aft Bulkhead | 1 | 296.8 | CL/CR |
| A526 | Light Baffle | 1 | 17.6 | CR |
| A531 | SI Purge Provisions | AR | 4.5 | CR |
| A560 | FSS Pin Assy. | 3 | 17.0 | CR |
| A561 | Vent Seals | 4 | 11.0 | CR |
| A565 | -V3 SI Cryogenic Vent Sys. | 1 | 5.7 | CR |
| A590 | Attach Parts | AR | 12.9 | E/PR/CR |
| A591 | Attach Parts to SI's | AR | 1.2 | PR |
| A595 | Equipment Mounts | AR | 0.7 | E/CR |
| Total Aft Shroud | | | 1143.4 | |
| A901 | SSM Attach Parts | | 6.7 | CR |
| A903 | ST Attach Parts | | 25.7 | PR/CR |
| A999 | Structure Contingency | | 16.0 | |
| Total Structure | | | 5292.5 | |
| (1% PR, 23% CR, 73% A, 2% PA, 1% S) | | | | |

| CODE | DESCRIPTION | NO. REQ'D | CURRENT WEIGHT (LB) | WEIGHT CLASS |
|-------------------------------------|-----------------------------|-----------|---------------------|--------------|
| Mechanisms | | | | |
| B105 | Aperture Door Mech. | 1 | 24.1 | CR/PA |
| B110 | Aperture Door Latch | 1 | 26.5 | CR |
| B115 | Latch Fitting Assy. | 1 | 1.7 | CR |
| B405 | Mech. Control Unit | 1 | 37.0 | S |
| B410 | Gimbal Control Electr. | 2 | 29.8 | A |
| B710 | S/A Latches | 4 | 115.2 | CR |
| B805 | HGA Extension/Retract | 2 | 151.5 | E/CR |
| B810 | HGA Latches | 4 | 104.2 | CR |
| B815 | HGA Gimbals | 2 | 44.2 | A |
| B825 | HGA ORU Provisions | 2 | 3.9 | CR |
| B999 | Mechanism Contingency | | 3.7 | |
| Total Mechanisms | | | 541.8 | |
| (11% E, 67% CR, 1% PA, 14% A, 7% S) | | | | |
| Thermal Control | | | | |
| C005 | OTA ES MLI/FOSR | AR | 20.4 | CR/A |
| C110 | Aperture Door FOSR | AR | 8.1 | CR |
| C115 | Aperture Door Chemglaze | AR | 3.8 | CR |
| C120 | Aperture Door MLI | AR | 0.6 | CR |
| C205 | Light Shield MLI - FOSR | AR | 89.2 | PR/CR/A |
| C220 | Light Shield Paint/Tape | AR | 21.3 | E/CR/A |
| C230 | Light Shield Heaters | AR | 0.2 | E/CR |
| C300 | Paint & Marking - FS | AR | 2.8 | E/CR |
| C305 | Fwd Shell MLI - FOSR | AR | 109.0 | CR/A |
| C310 | HGA MLI - Waveguide/Boom | AR | 6.0 | CR |
| C405 | Equip. Sect. MLI - FOSR | AR | 81.6 | PR/CR/A |
| C415 | Equip. Sect. Chemglaze | AR | 6.8 | CR |
| C450 | Heat Sink | 3 | 43.1 | CL/A |
| C460 | Louvers, Bays 2 & 3 | 2 | 26.3 | CL |
| C505 | Aft Shroud MLI | AR | 34.1 | CR/A |
| C510 | Aft Shroud FOSR | AR | 57.7 | E/CR |
| C515 | Aft Shroud Chemglaze | AR | 12.5 | CR |
| C525 | Aft Shroud Rad. Shield | AR | 66.8 | CR |
| C530 | Aft Shroud Heaters | AR | 0.1 | |
| C999 | Thermal Control Contingency | | 13.2 | |
| Total Thermal Control | | | 603.4 | |
| (5% CL, 56% CR, 39% A) | | | | |
| Electrical Power | | | | |
| D105 | Ap. Dr. Temp. Sensor Wire | | 1.6 | C |
| D205 | Light Shield Wire Harn | AR | 21.1 | A |
| D210 | Light Shield Wire Harn Supt | AR | 19.3 | CR/A |
| D305 | Fwd Shell Wire Harn | AR | 59.6 | CL/S/A |

| CODE | DESCRIPTION | NO. REQ'D | CURRENT WEIGHT (LB) | WEIGHT CLASS |
|--|---|-----------|---------------------|--------------|
| D310 | Fwd Shell Wire Harn Supt | AR | 23.0 | CR/A |
| D405 | Equip. Sect. Wire Harn | AR | 588.5 | CL/CR/A |
| D410 | Equip. Sect. Wire Harn Supt | AR | 73.3 | PR/CR/A |
| D415 | Pwr Distr Box | 4 | 117.3 | A |
| D416 | Pwr Control Unit | 1 | 150.8 | A/CR |
| D420 | Batteries-Type 40 | 6 | 807.8 | A |
| D430 | Charge Controllers | 6 | 18.0 | PA/A |
| D505 | Aft Shroud Wire Harness | AR | 52.7 | E/CR/A |
| D510 | Aft Shroud Wire Harn Supt | AR | 11.5 | E/PR/CR |
| D515 | Grounding Studs | 11 | 2.0 | E |
| D535 | Umbilical | 1 | 60.0 | E/CR/A |
| D540 | Emergency FSS Umbilical | 1 | 12.7 | PR |
| D999 | Electrical Power Contingency Round off | | 24.8 -0.2 | |
| Total Electrical Power (2% E, 1% CL, 1% PR, 6% CR, 90% A) | | | 2043.8 | |
| Communication & Instrumentation | | | | |
| E010 | Temp Sensors - Vehicle | 195 | 0.4 | PR/CR/A |
| E205 | Light Shield LGA | 1 | 0.6 | CR |
| E206 | Waveguide LGA - Light Shld | AR | 32.6 | A |
| E306 | Waveguide LGA - Fwd Shell | AR | 21.7 | CR/A |
| E307 | Waveguide HGA - Fwd Shell | AR | 25.8 | CR/A |
| E405 | SA Transmitter | 2 | 25.3 | A |
| E410 | MA Transponder | 2 | 14.1 | A |
| E415 | Diplexer | 2 | 1.8 | A |
| E420 | Coax-Eqp. Sect. | AR | 23.9 | CR/A |
| E425 | Circulator Switch | 1 | 1.3 | A |
| E430 | RF Switch | 2 | 1.2 | S |
| E435 | RF Multiplexer | 2 | 2.1 | A |
| E440 | Transfer Switch | 2 | 0.5 | A |
| E445 | Instr. Control Unit | 1 | 26.9 | E/PR |
| E470 | EMI Seals | AR | 12.2 | CR/A |
| E505 | Aft Shroud LGA | 1 | 0.7 | CR |
| E506 | Waveguide LGA - Aft Shroud | AR | 28.2 | CR |
| E815 | HG Antenna Feed | 2 | 13.6 | A |
| E999 | Comm. & Instr. Contingency | | 4.0 | |
| Total Comm. & Instr. (11% E, 33% CR, 55% A, 1% S) | | | 236.9 | |

| CODE | DESCRIPTION | NO. REQ'D | CURRENT WEIGHT (LB) | WEIGHT CLASS |
|-------------------------------|-------------------------------------|-----------|---------------------|--------------|
| Data Management | | | | |
| F405 | Computer (DF224) | 1 | 111.5 | A |
| F410 | Data I/F Unit | 3 | 102.1 | E/PA |
| F415 | Data Mgt Unit | 1 | 94.7 | PA |
| F420 | Oven Controlled Crystal Oscillator | 2 | 5.6 | A |
| F430 | Science Tape Recorder | 1 | 20.5 | A |
| F435 | Eng. Tape Recorder | 2 | 40.9 | A |
| F999 | Data Mgt Contingency | | 0.5 | |
| | Round off | | -0.1 | |
| Total Data Management | | | 375.7 | |
| (1% E, 52% PA, 47% A) | | | | |
| Pointing Control | | | | |
| G200 | Coarse Sun Sensors - Fwd | 2 | 1.8 | CR |
| G205 | Magnetometer/Electronics | 2 | 4.7 | A |
| G305 | Magnetic Torquers | 4 | 382.8 | A |
| G405 | Retrieval Mode Gyro Assy | 1 | 3.0 | A |
| G412 | Pointing System Electronics | 1 | 85.5 | A |
| G416 | Reaction Wheels & Supt Ring | 4 | 414.0 | A |
| G505 | FHST Light Seal Instl. | 3 | 17.8 | CR |
| G510 | Coarse Sun Sensors - AFT | 2 | 1.0 | CR |
| G600 | ECU's for RSU's | 3 | 52.0 | CR/PA/A |
| G605 | Fixed Head Star Tracker Assy. | 3 | 117.8 | CR |
| G610 | Rate Sensing Unit | 3 | 71.8 | CR/PA/A |
| G999 | Pointing Control Contingency | | 1.4 | |
| | Round Off | | +0.1 | |
| Total Pointing Control | | | 1153.7 | |
| (12% CR, 7% PA, 81% A) | | | | |
| Crew Systems | | | | |
| H000 | OTA ES Translation Rails | AR | 12.7 | A |
| H110 | Handles and Tether Loops | AR | 1.5 | A |
| H115 | Grapple Fixture Recpt. | 1 | 1.1 | A |
| H205 | Light Shield Reflectors | 2 | 0.2 | E |
| H210 | Light Shield Trans Rails | AR | 18.7 | A |
| H215 | Foot Restraint Receptacle | 3 | 2.3 | CR |
| H305 | Fwd Shell Trans Rails | AR | 25.7 | A |
| H315 | Foot Restraint Recep. & Tether Att. | 8 | 7.4 | A |
| H405 | Equip Sect Translation Rails | AR | 22.1 | CR/A |
| H410 | Handles and Tether Loops | AR | 7.2 | CR/A |
| H415 | Panel - Pwr & Light | 1 | 5.4 | E/CR |
| H505 | SI Guide Rails & STR. | AR | 81.3 | CL/CR |
| H535 | Aft Shroud Trans Rails | AR | 145.4 | CR |
| H540 | Aft Shroud Reflectors | 2 | 1.8 | PR/CR |
| H550 | Door Handles - AFT Shroud | 6 | 6.3 | CR |
| H555 | Tether/Purge FTG - SI/FGS | AR | 2.2 | E |

| CODE | DESCRIPTION | NO. REQ'D | CURRENT WEIGHT (LB) | WEIGHT CLASS |
|--|---|-----------|---------------------|--------------|
| H560 | Bump Guards | 4 | 18.9 | CR |
| H999 | Crew Systems Contingency | | 3.9 | |
| | Total Crew Systems (1% E, 2% CL, 69% CR, 28%A) | | 364.1 | |
| V100 | Actual wt. - AP Door Structure | | -7.1 | A |
| V200 | Actual wt. - LS Structure | | +6.4 | A |
| V300 | Actual wt. - FS Structure | | +0.1 | A |
| V400 | Actual wt. - ES Complete | | -17.4 | A |
| | Total Manufacturing Variations (100% A) | | -18.0 | |
| | Total SSM (1% E, 1% CL, 1% PR, 24% CR, 3% PA, 1% S, 69% A) | | 10,593.9 | |
| <u>4.2 Optical Telescope Assy. (OTA)</u> | | | | |
| | OTA | | 9025.2 | |
| | Contingency | | 8.2 | |
| | Total OTA (Current weight) (6% C, 94% A) | | 9033.4 | |
| <u>4.3 Solar Array (SA)</u> | | | | |
| M701 | Deployment Control Electronics | 1 | 22.1 | PA |
| M702 | Drive Electronics | 2 | 31.8 | PA |
| M703 | Solar Blankets | 4 | 164.5 | PA |
| M705 | Secondary Deployment Mechanism | 2 | 252.1 | PA |
| M706 | Primary Deployment Mechanism | 2 | 93.2 | PA |
| M710 | ORU Provisions - SSM | AR | 17.5 | CR/A |
| M715 | Grapple Fixture Receptacle -SSM | 2 | 0.9 | CR |
| M720 | Latch Interface Fittings - SSM | 4 | 10.1 | A |
| M730 | Diode Box - SSM | 2 | 13.9 | A |
| M740 | Diodes | 2 | 13.9 | PA |
| M750 | SA Drive Mechanism (Rotate/Fix) | 2 | 95.2 | PA |
| M755 | SA Drive Adapter | 2 | 15.3 | PA |
| M760 | Fittings | 4 | 1.1 | PA |
| M770 | Harnesses | 2 | 3.6 | PA |
| M999 | BAe Contingency | | 0.0 | |
| M999 | SSM Contingency | | 0.2 | |
| | Total SA (4% CR, 92% PA, 4% A) | | 735.4 | |

| CODE | DESCRIPTION | NO. REQ'D | CURRENT WEIGHT (LB) | WEIGHT CLASS |
|--|---------------------------|-----------|---------------------|--------------|
| <u>4.4 Faint Object Camera (FOC)</u> | | | | |
| J605 | FOC | | 706.0 | |
| J605 | Contingency | | 0.0 | |
| | Total FOC (100%A) | | 706.0 | |
| <u>4.5 Faint Object Spectrograph (FOS)</u> | | | | |
| J610 | FOS | | 682.1 | |
| J610 | Contingency | | 0 | |
| | Total FOS (100%A) | | 682.1 | |
| <u>4.6 High Resolution Spectrometer (HRS)</u> | | | | |
| J620 | HRS | | 684.7 | |
| J620 | Contingency | | 0 | |
| | Total HRS (100% A) | | 684.7 | |
| <u>4.7 High Speed Photometer (HSP)</u> | | | | |
| J630 | HSP | | 586.8 | |
| J630 | Contingency | | 0.0 | |
| | Total HSP (100% A) | | 586.8 | |
| <u>4.8 Wide Field & Planetary Camera (WF & PC)</u> | | | | |
| K605 | WF & PC | | 568.6 | |
| K605 | Contingency | | 0 | |
| | Total WF & PC (100% A) | | 568.6 | |
| <u>4.9 Scientific Instruments C&DH (SI C&DH)</u> | | | | |
| R405 | STINT | | 5.1 | A |
| R405 | CPM | | 4.4 | A |
| R405 | Memory | | 24.7 | A |
| R405 | BCU | | 0.2 | A |
| R405 | RIU | | 9.3 | A |

| CODE | DESCRIPTION | NO. REQ'D | CURRENT WEIGHT (LB) | WEIGHT CLASS |
|------|---|-----------|---------------------|--------------|
| R405 | PCU | | 14.8 | A |
| R405 | CU/SDF | | 35.9 | A |
| R405 | Harnesses | | 17.3 | A |
| R405 | Hardware | | 1.2 | A |
| R405 | EVA Safety | | 2.1 | A |
| R406 | Handle & Tether Loop(SSM) | | 1.8 | A |
| R410 | ORU Provisions (SSM) | | 18.6 | A |
| R407 | Contingency (C&DH) | | 0.0 | |
| R999 | Contingency (SSM) | | 0.0 | |
| | Miscellaneous | | +0.5 | |
| | Total SI C&DH (100% A) | | 135.9 | |
| 4.10 | <u>Total ST</u> (1% E, 13% C, 86% A) | | 23,726.8 | |

5.0 MASS PROPERTIES (1) (6)
5.1 ST Mass Properties

LMSC/D974197B
31 May 1985

| Description | (LB) Wt. | (IN.) | | | (5) Slug-FT ² | | | | | |
|--------------------------------|-------------|-------|-------|-------|--------------------------|--------|--------|---------|-------|-------|
| | | V1 | V2 | V3 | IV1 | IV2 | IV3 | IV1V2 | IV1V3 | IV2V3 |
| OTA Suspended | 8434.3 | 239.6 | -0.2 | 0.2 | 3666 | 7679 | 7734 | 10.6 | 25.3 | 13.9 |
| FOS | 682.1 | 161.9 | 18.0 | -18.8 | 24 | 96 | 96 | 1.3 | -1.0 | -3.4 |
| FOC | 706.0 | 162.8 | -16.5 | -16.0 | 21 | 110 | 111 | 1.9 | 2.6 | 8.1 |
| HRS | 684.7 | 168.5 | 18.4 | 18.7 | 22 | 115 | 114 | -2.2 | 3.4 | -5.1 |
| HSP | 586.8 | 165.8 | -17.3 | 17.7 | 28 | 101 | 91 | -0.8 | -1.0 | 2.0 |
| WF/PC | 568.6 | 219.2 | 0.4 | -51.6 | 49 | 44 | 29 | 0.2 | -1.9 | -0.2 |
| FHST/RSU | 191.3 | 192.8 | -5.1 | -56.8 | 24 | 3 | 24 | 0.0 | -0.4 | -0.9 |
| Total Suspended at STA 240. | 11,853.8 | 221.1 | 0.1 | -3.3 | 4628 | 11,251 | 10,868 | -20.5 | 150.1 | 27.1 |
| FHST SHADE/SEAL INSTL | 18.0 | 180.1 | 0 | -74.2 | 2 | 0 | 2 | 0 | 0 | 0 |
| SSM STOWED (2)(7) | 10,449.5 | 298.9 | 0.3 | -6.3 | 11,661 | 34,061 | 33,800 | -75.3 | 554.5 | -25.0 |
| Solar Array DPLD (3) | 636.1 | 319.5 | 0.0 | 0.0 | 4476 | 909 | 3583 | 0.0 | 0.0 | -2.5 |
| Solar Array Stowed | 636.1 | 390.8 | 0.0 | 0.0 | 861 | 474 | 1332 | 0.0 | 0.0 | -1.1 |
| OTA Equip. Section | 734.4 | 317.9 | 2.2 | -60.6 | 368 | 84 | 362 | 1.3 | -2.4 | 2.5 |
| ATTACH-ST | 35.2 | 339.9 | 0.6 | -3.8 | 35 | 113 | 129 | -0.5 | 1.2 | 0.1 |
| ST Stowed | 23,726.8 | 263.1 | 0.2 | -6.4 | 18,069 | 56,692 | 56,689 | -59.6 | 40.0 | -14.2 |
| ST Deployed(3)0° | 23,726.8 | 260.4 | 0.2 | -6.1 | 23,279 | 56,262 | 56,480 | -55.4 | 521.3 | -15.1 |
| ST Deployed(4)90° | 23,726.8 | 260.4 | 0.2 | -6.1 | 22,386 | 56,273 | 57,384 | -57.7 | 526.6 | -12.8 |
| ST Stowed + SSE | 24,026.8 | 260.7 | 1.3 | -6.3 | 18,554 | 58,783 | 59,264 | -1001.1 | 7.5 | -0.4 |

- (1) SEE FIG. 5-1 FOR ST AXIS SYSTEM; ALL MASS PROPERTIES ARE CENTROIDAL.
- (2) INCLUDES SOLAR ARRAY DRIVE ELECTRONICS (2), SA DEPLOYMENT CONTROL ELECTRONICS, OTA WIRE HARNESES, AND THE SI C&DH.
- (3) SOLAR ARRAY WINGS IN ZERO REFERENCE POSITION.
- (4) SOLAR ARRAY WINGS ROTATED 90°.
- (5) IN FORMING AN INERTIA MATRIX (INERTIA TENSOR), MULTIPLY ALL PRODUCTS OF INERTIA BY (-1).
- (6) DUE TO ROUND OFF, ST TOTAL WEIGHT IN THIS TABLE IS 0.1 LB. HEAVIER THAN THE TOTAL IN THE SUMMARY WEIGHT STATEMENT.
- (7) GRAPPLE FIXTURE MASS PROPERTIES INCLUDED IN THE SSM ARE: W = 22.5 LB., V1 = 358.3, V2 = 46.0, V3 = -64.3, IV1 = 0.2, IV2 = 0.2, IV3 = 0.3; SAME UNITS AS ABOVE

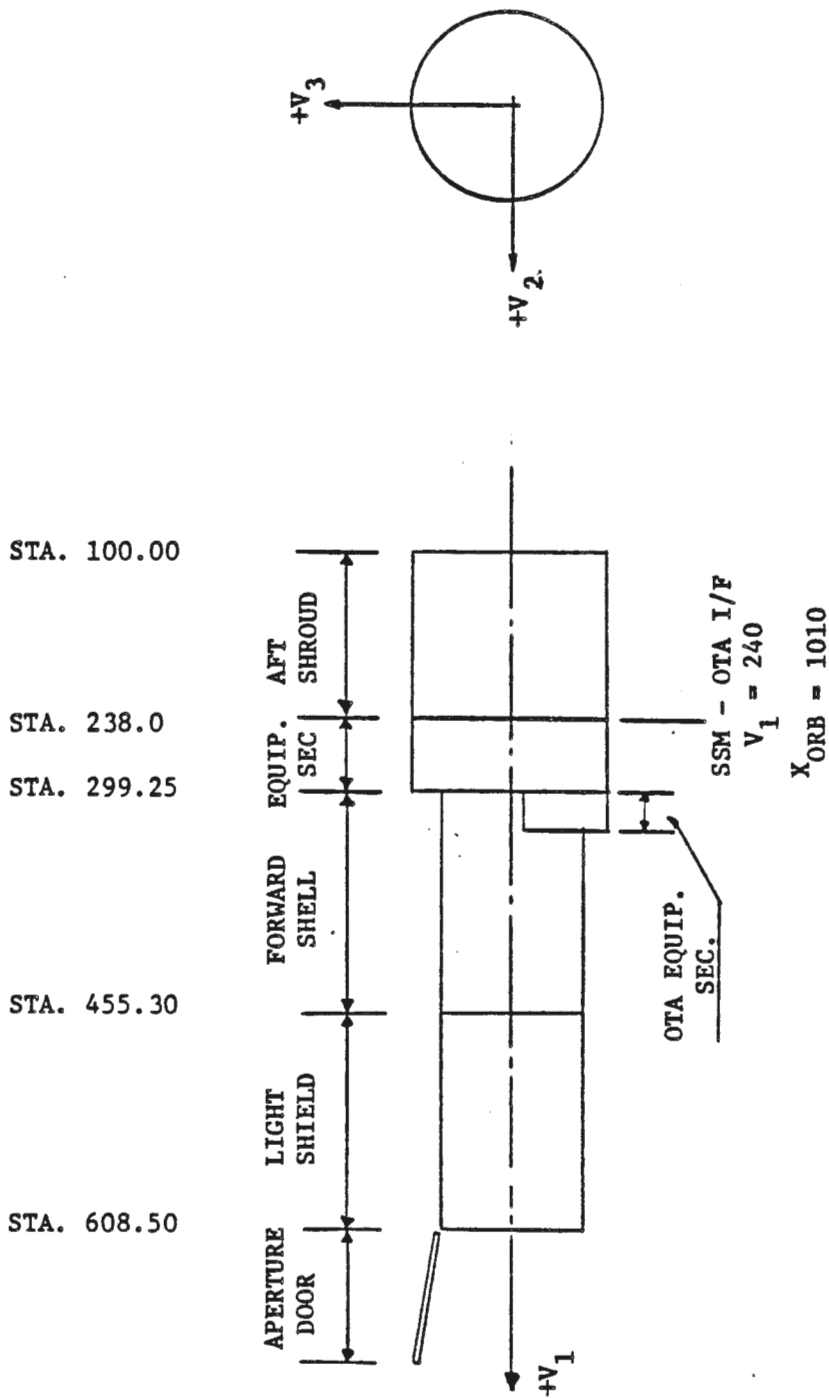

WHEN STOWED IN THE ORBITER, THE RELATION BETWEEN ST COORDINATES AND ORBITER COORDINATES IS:

$$X_{\text{ORBITER}} = 1250 - V_1$$

$$Y_{\text{ORBITER}} = +V_2$$

$$Z_{\text{ORBITER}} = 400 - V_3$$

6.0 CRITICAL MASS PROPERTIES SUMMARY

6.1 Mass Properties Compatibility with PCS Capability

| <u>Requirement</u> | <u>Current(1) Value</u> | <u>Remarks</u> |
|---|-------------------------------|---|
| A. 1. $I_{MAX} \leq 62,500$ $S-F^2$ | IV3 = 57,384 S-F ² | 1. Meet ST attitude slewing requirement with baseline RWA design. |
| 2. $I_{MAX} - I_{MIN}$ $\leq 40,900 S-F^2$ | 34,998 S-F ² | 2. Limit MAX CG torque for selected magnetic-torquer size. |
| 3. PRODUCT OF INERTIA $\leq 2000 S-F^2$ | 527 S-F ² = MAX | 3. To meet PCS Pointing performance. |

The above limits will be maintained with all appendages deployed and any orientation of the solar array wings.

| | | |
|---|------------------------|---|
| B. 1. I_{MAX} - $I_{Intermediate}$ $\geq 500 S-F^2$ | 1,812 S-F ² | 1. Partial capability for passive GG stabilization by mass properties |
| 2. $V1 = 260 \pm 30$ in. | 261.2 in. | |
| 3. $V2 = 0 \pm 2$ in. | +0.25 in. | 2.,3.,4. C.G. constraints limit aerodynamic torques. |
| 4. -8 in $\leq V3 \leq -4$ in. | -6.38 in. | |

The above limits will be maintained with the aperture door closed, and the high gain antennas retracted, and any orientation of the solar array wings. All dimensions specified are from the center of V1-V2-V3 coordinate system.

C. Current ST mass properties meet the requirements stated in A & B.

6.2 Orbiter Payload C.G. Limits

6.2.1 C.G. limit curves are specified in ICD-19001. The payload is defined as STPO provided hardware (ST+SSE).

| | Wt.(lb.) | Inches | | |
|-------------|----------|-----------------|------|----------------|
| | | Xo | Yo | Zo |
| ST (STOWED) | 23,727 | 987.0 | 0.2 | 406.4 |
| SSE* | 300 | 1169.8 | 80.8 | 403.7 |
| TOTAL STPO | 24,027 | 989.3 | 1.3 | 406.3 |
| LIMITS** | 27,700 | 922.7 1123.1 | +4.1 | 439.9 294.8 |

*SSE Centers of Gravity are WAG.

**Weight limit specified in STR-04B, ST to Orbiter I/F; Center of gravity limits are per graphs in ICD 2-19001, Shuttle Orbiter/Cargo Standard Interfaces.

7.0 PENDING AND POTENTIAL CHANGES - SSM

7.1 SSM

PENDING

- 1) RWA isolators, EJA27101 (+101 lb.).
- 2) RWA harness rework, EJA29601 (+2 lb.).
- 3) Add battery protection and reconditioning circuit, EJA30701 (+58 lb.).
- 4) Add UV filter, EJA31001 (+4 lb.).

POTENTIAL

- 1) Starboard grapple fixture to ORU (+11 lb.).

7.2 OTA

POTENTIAL

- 1) Bulkhead MLI for connectors - August 1983 weight review (+10 lb.).

7.3 HRS

POTENTIAL

- 1) No potential changes reported.

7.4 FOC

POTENTIAL

- 1) No potential changes reported.

9.0 REFERENCES (uncited)

1. LMSC/F020600, 25 October 1984, ST Mass Properties Report No. 28.
2. Perkin-Elmer, OTA Mass Properties Report, No. 31, January 1985.
3. BAe, TN-SA-B012, Rev. N, February 1982, SA Mass Properties Report; and telecon update, 12 September 1983, S. Broadhead, LMSC, to R. White, GSF
4. WFPC - MOIs are based on 28 May 1980 report, weight and c.g.s are based on 7 February 1984 Quarterly Review Charts and adjusted for GFE hardware
5. HSP - Mass properties based on 7 February 1984 Quarterly Review Charts.
6. HRS - Ball Aerospace Systems Division, data based on 7 February 1984 Quarterly Review Charts.
7. FOC - C. G. based on 12 May 1983 Report, weight based on 7 February 1984 Quarterly Review Charts.
8. FOS - Martin Marietta Corp., weight based on rapifax dated 27 September 1984, and c.g. based on 5 October 1983 Quarterly Review Chart, and the MOI's are based on Report dated 19 September 1983.
9. SI C&DH - 13 April 1983 Mass Properties Report, 919-SR3001-17.

APPENDIX B

SPACE TELESCOPE and CREW SYSTEMS

Document Trees

LMSC 4175840 G

NOV '82/ REV MAR '83
AUG '83 / SEP '83/FEB 22 '84
APR 23 '84/NOV 21 '84/JUN 04 '85

SPACE TELESCOPE DOCUMENT TREE

MODEL: 003305

SE-07

REVISED EDITION
JUN 1985

SUBMITTED IN ACCORDANCE WITH REQUIREMENTS OF
CONTRACT NAS -8-32697. MODIFICATION



3

59-90-90
HJ3M INSS

LMSC/D974197B
31 May 1985

LMSC 4175840

NOV '82/ REV MAR '83
AUG '83 / SEP '83/FEB 22 '84
JUN '85

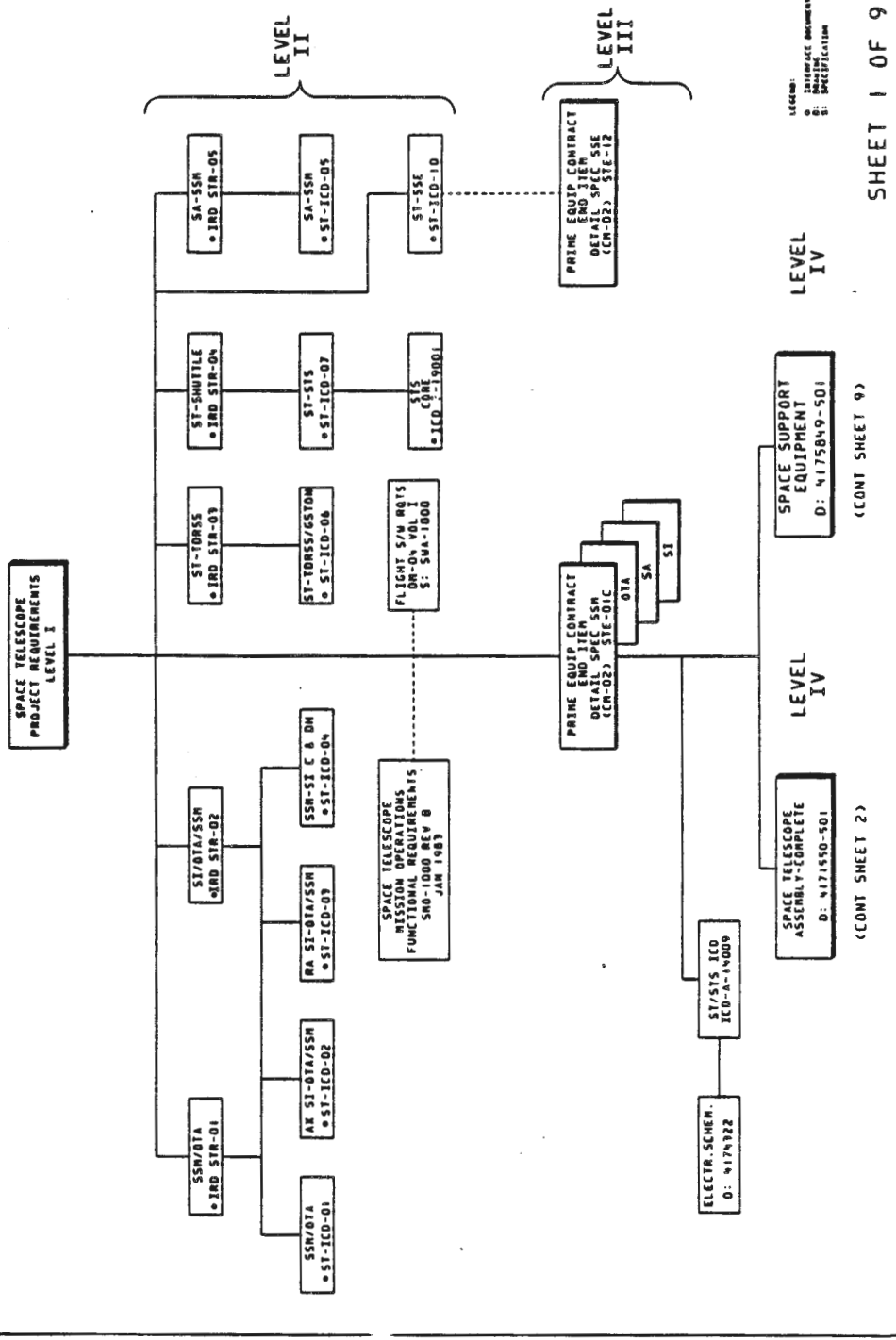

LMSC 4175840

NOV '82/ REV MAR '83
AUG '83 / SEP '83/FEB 22 '84
APR 23 '84/NOV 21 '84 /JUN 04 '85

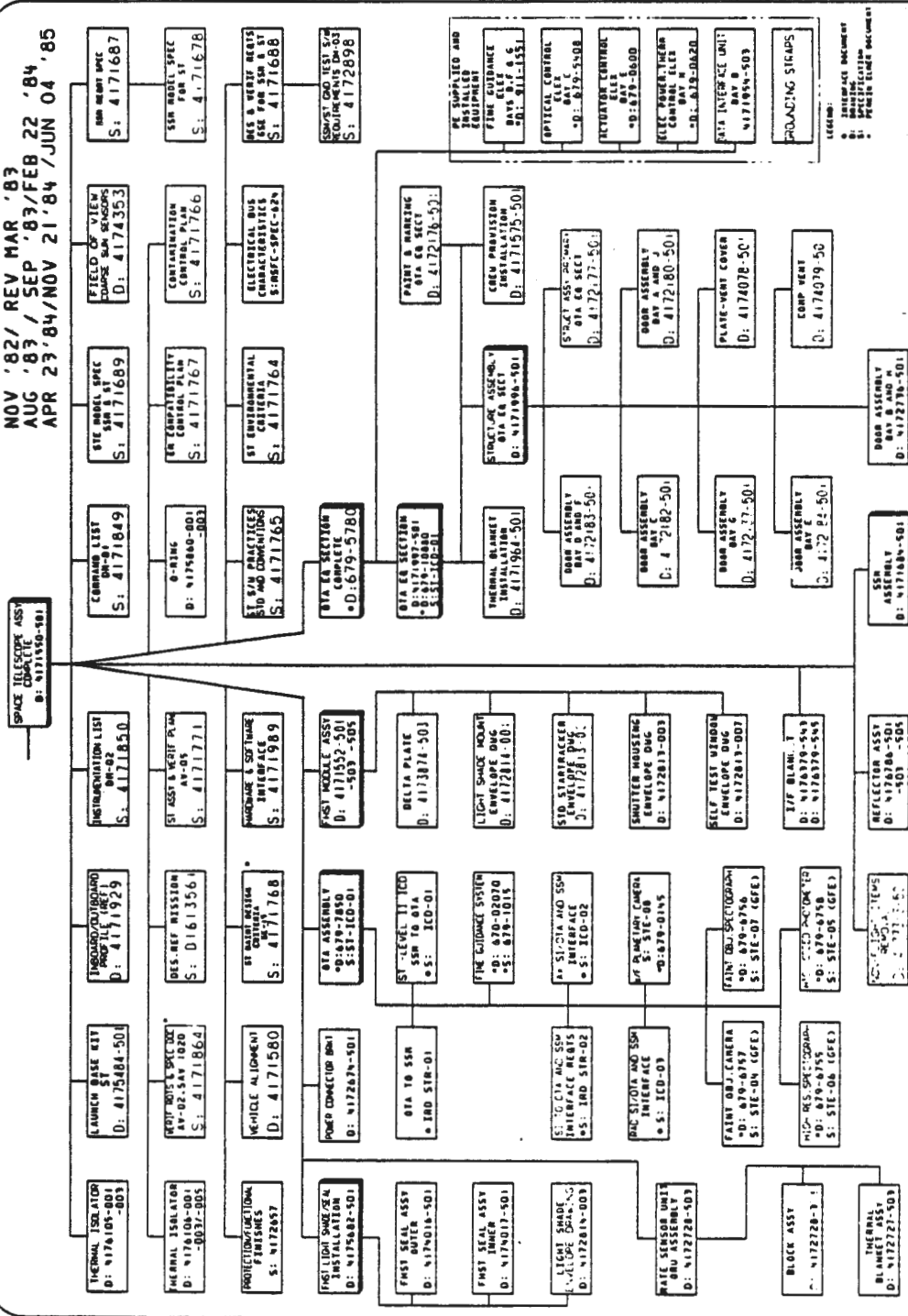

LEGEND:
 D: DRAWING DOCUMENT
 S: SPECIFICATION
 P: PART NUMBER DOCUMENT

SHEET 2

(CONT SHEET 3)

LMSC N17590
REV 02 / REV MAR 83 / AME 03 / SEP 81

CONT. SHEET 4

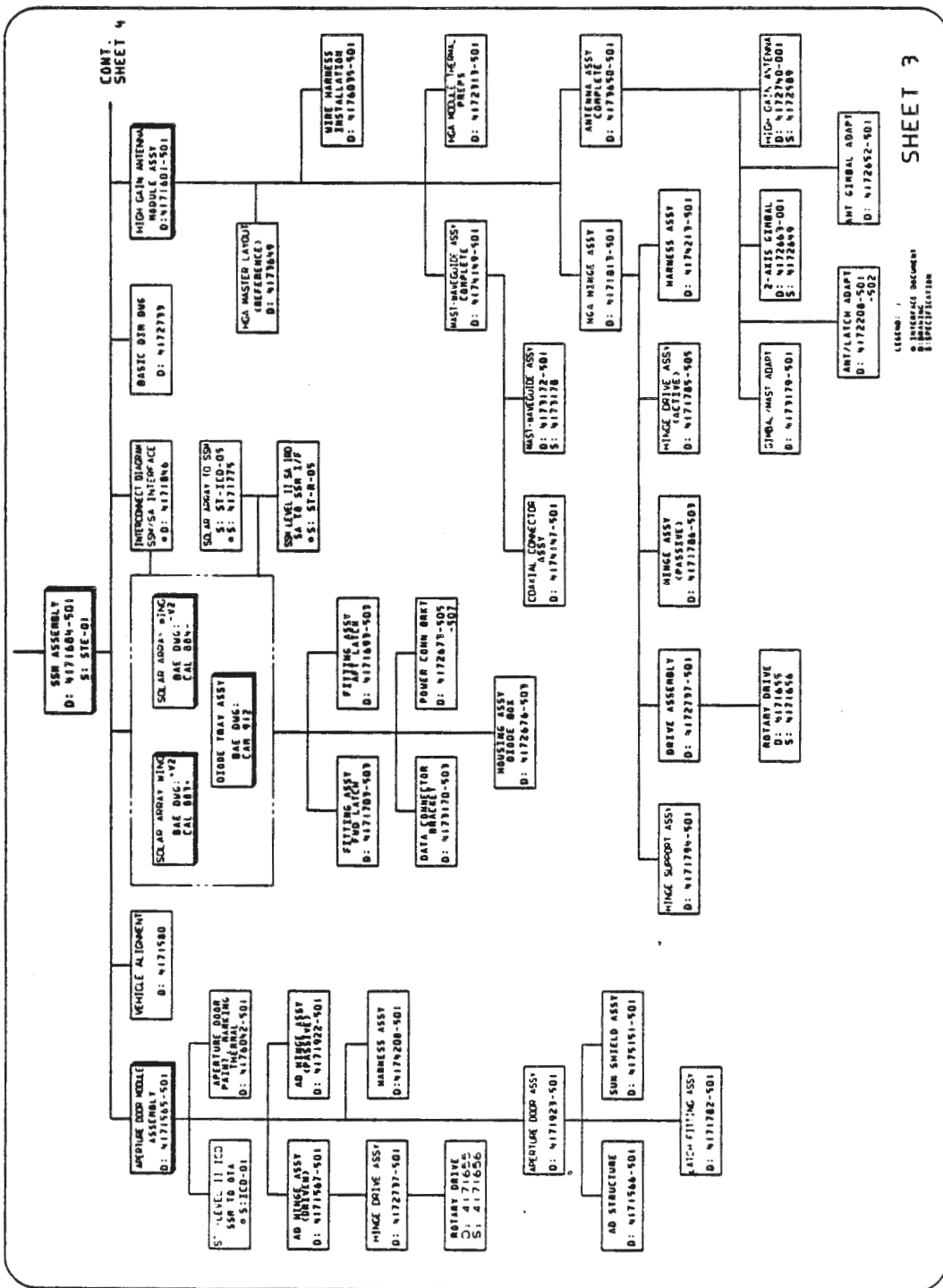

SHEET 3

LEGEND:
1. UNPROCESSED DOCUMENT
2. WORKING DRAWING
3. SPECIFICATION

69-90-90
H334-1N55

11/9/15

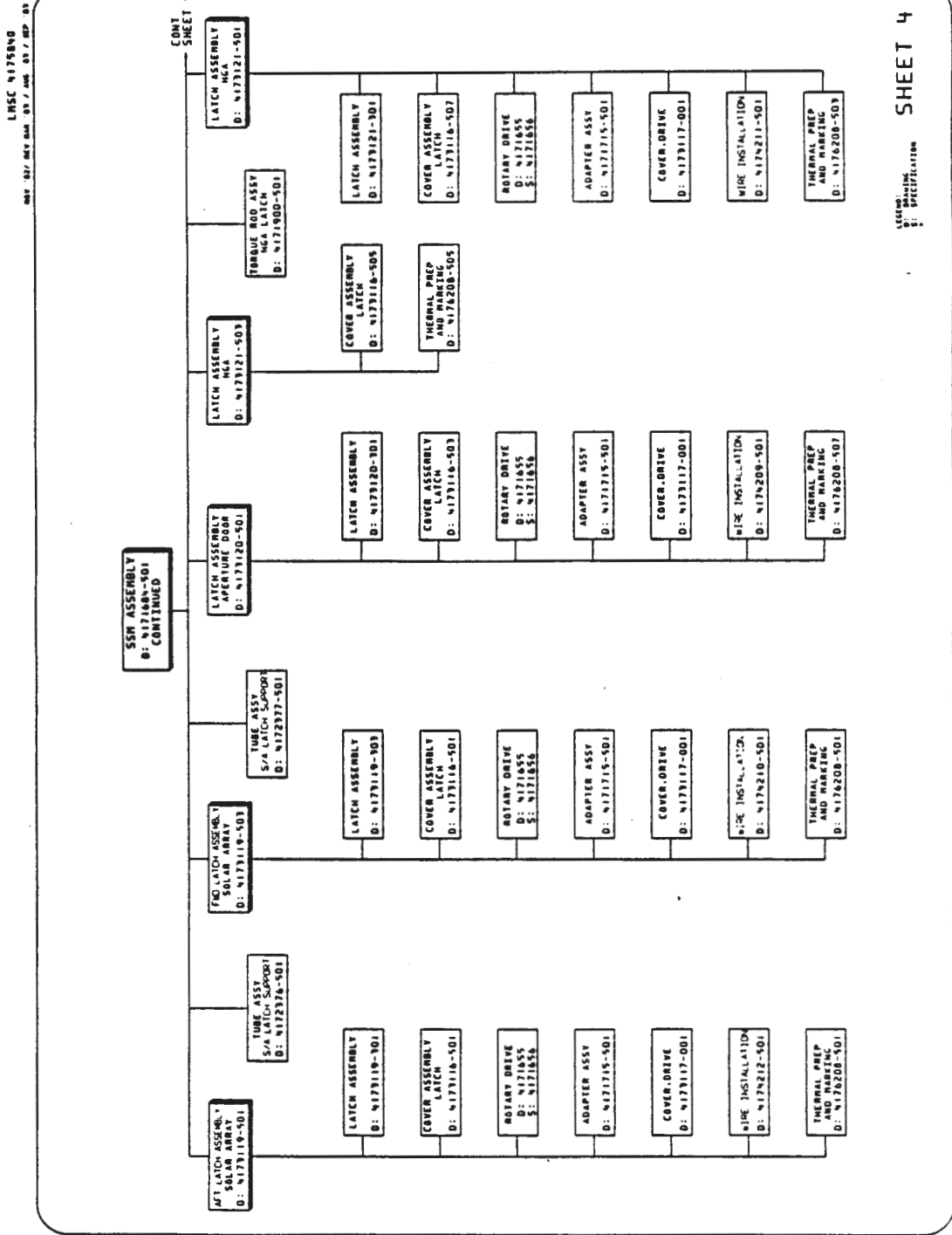

LMSC 4175840

NOV '82 / REV MAR '83
REV AUG '83 / FEB '84
NOV 21 '84 / JUN 05 '85

SSR ASSEMBLY
D: 4171684-501
CONTINUED

CONT.
SHEET 7

AFT SHROUD ASSY
COMPLETE
D: 4171500-501

TERMINAL BOARD
WIRE HARNESS BRIDGE
D: 4177205-501
D: 4177206-501
D: 4177207-501

AIRLINE PURGE SYST
D: 4175199-501

INSTRUMENTIZATION
D: 4171607-501

SUR SENSORS
D: 4177026-501

LOW GAIN ANTENNA
D: 4177757-503

TAPE AND MARKING
D: 4171599-501

TERMINAL BOARD
INSTALLATION
D: 4171592-501

WIRE HARNESS
INSTALLATION
D: 4175993-501

TERMINAL BOARD
WIRE HARNESS BRIDGE
D: 4177205-501
D: 4177206-501
D: 4177207-501

AIRLINE PURGE SYST
D: 4175199-501

INSTRUMENTIZATION
D: 4171607-501

SUR SENSORS
D: 4177026-501

LOW GAIN ANTENNA
D: 4177757-503

TAPE AND MARKING
D: 4171599-501

TERMINAL BOARD
INSTALLATION
D: 4171592-501

WIRE HARNESS
INSTALLATION
D: 4175993-501

TERMINAL BOARD
WIRE HARNESS BRIDGE
D: 4177205-501
D: 4177206-501
D: 4177207-501

AIRLINE PURGE SYST
D: 4175199-501

INSTRUMENTIZATION
D: 4171607-501

SUR SENSORS
D: 4177026-501

LOW GAIN ANTENNA
D: 4177757-503

TAPE AND MARKING
D: 4171599-501

TERMINAL BOARD
INSTALLATION
D: 4171592-501

WIRE HARNESS
INSTALLATION
D: 4175993-501

TERMINAL BOARD
WIRE HARNESS BRIDGE
D: 4177205-501
D: 4177206-501
D: 4177207-501

AIRLINE PURGE SYST
D: 4175199-501

INSTRUMENTIZATION
D: 4171607-501

SUR SENSORS
D: 4177026-501

LOW GAIN ANTENNA
D: 4177757-503

TAPE AND MARKING
D: 4171599-501

TERMINAL BOARD
INSTALLATION
D: 4171592-501

WIRE HARNESS
INSTALLATION
D: 4175993-501

TERMINAL BOARD
WIRE HARNESS BRIDGE
D: 4177205-501
D: 4177206-501
D: 4177207-501

AIRLINE PURGE SYST
D: 4175199-501

INSTRUMENTIZATION
D: 4171607-501

SUR SENSORS
D: 4177026-501

LOW GAIN ANTENNA
D: 4177757-503

TAPE AND MARKING
D: 4171599-501

TERMINAL BOARD
INSTALLATION
D: 4171592-501

WIRE HARNESS
INSTALLATION
D: 4175993-501

TERMINAL BOARD
WIRE HARNESS BRIDGE
D: 4177205-501
D: 4177206-501
D: 4177207-501

AIRLINE PURGE SYST
D: 4175199-501

INSTRUMENTIZATION
D: 4171607-501

SUR SENSORS
D: 4177026-501

LOW GAIN ANTENNA
D: 4177757-503

TAPE AND MARKING
D: 4171599-501

TERMINAL BOARD
INSTALLATION
D: 4171592-501

WIRE HARNESS
INSTALLATION
D: 4175993-501

TERMINAL BOARD
WIRE HARNESS BRIDGE
D: 4177205-501
D: 4177206-501
D: 4177207-501

AIRLINE PURGE SYST
D: 4175199-501

INSTRUMENTIZATION
D: 4171607-501

SUR SENSORS
D: 4177026-501

LOW GAIN ANTENNA
D: 4177757-503

TAPE AND MARKING
D: 4171599-501

TERMINAL BOARD
INSTALLATION
D: 4171592-501

WIRE HARNESS
INSTALLATION
D: 4175993-501

TERMINAL BOARD
WIRE HARNESS BRIDGE
D: 4177205-501
D: 4177206-501
D: 4177207-501

AIRLINE PURGE SYST
D: 4175199-501

INSTRUMENTIZATION
D: 4171607-501

SUR SENSORS
D: 4177026-501

LOW GAIN ANTENNA
D: 4177757-503

TAPE AND MARKING
D: 4171599-501

TERMINAL BOARD
INSTALLATION
D: 4171592-501

WIRE HARNESS
INSTALLATION
D: 4175993-501

TERMINAL BOARD
WIRE HARNESS BRIDGE
D: 4177205-501
D: 4177206-501
D: 4177207-501

AIRLINE PURGE SYST
D: 4175199-501

INSTRUMENTIZATION
D: 4171607-501

SUR SENSORS
D: 4177026-501

LOW GAIN ANTENNA
D: 4177757-503

TAPE AND MARKING
D: 4171599-501

TERMINAL BOARD
INSTALLATION
D: 4171592-501

WIRE HARNESS
INSTALLATION
D: 4175993-501

TERMINAL BOARD
WIRE HARNESS BRIDGE
D: 4177205-501
D: 4177206-501
D: 4177207-501

AIRLINE PURGE SYST
D: 4175199-501

INSTRUMENTIZATION
D: 4171607-501

SUR SENSORS
D: 4177026-501

LOW GAIN ANTENNA
D: 4177757-503

TAPE AND MARKING
D: 4171599-501

TERMINAL BOARD
INSTALLATION
D: 4171592-501

WIRE HARNESS
INSTALLATION
D: 4175993-501

LEGEND
D: DRAWING
S: SPECIFICATION

SHEET 6

68-90-90
HJ334 IN55

10'8'15

LMSC 4175840

REV 02/ REV MAR '83
REV AUG '87/ REV FEB '84
JUN 05 '85

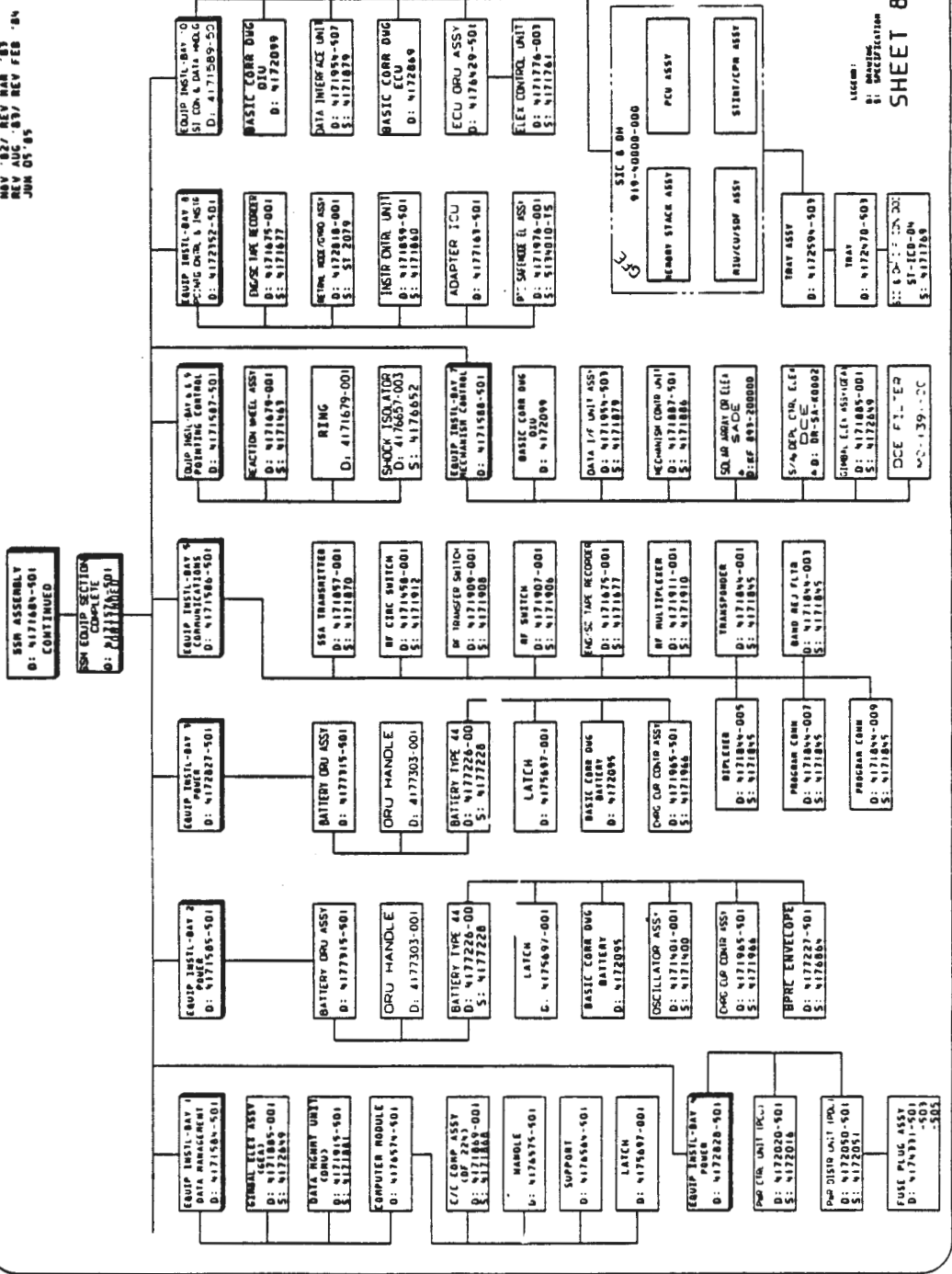

55N1-MECH
90-06-85

LMSC 4175840

SHEET ADDED
JUN 05 '85

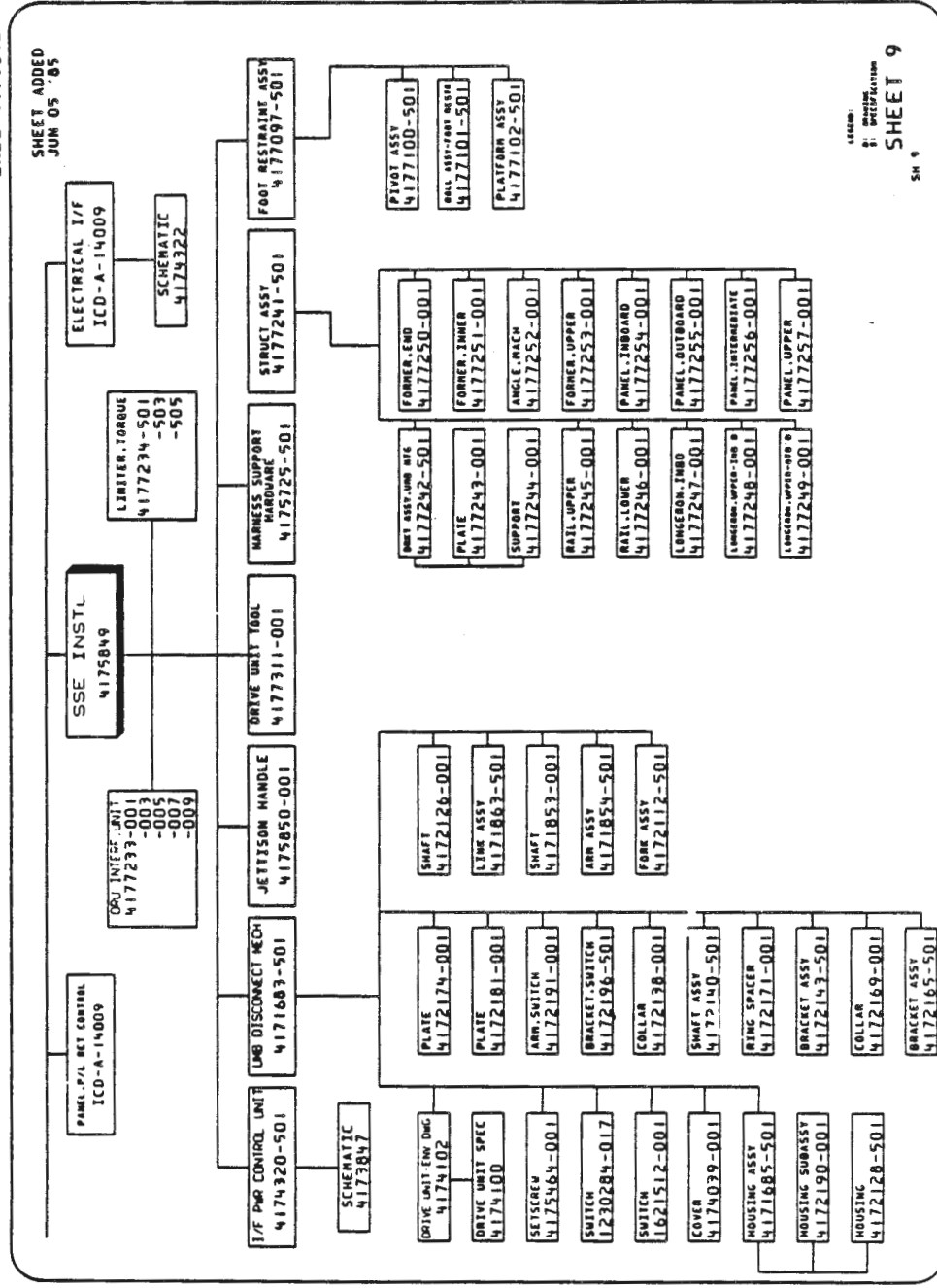

LEGEND
1: DIMENSION
2: IDENTIFICATION
SHEET 9
SH 9

OPTICAL TELESCOPE ASSEMBLY
Specification Tree
DR SE-07

Optical Telescope Assembly (OTA) ----- LEVEL 1
DWG 679-7850 OTA, Drawing
STE-02, Prime Equipment, Contract End Item (CEI),
Detail Specification, Part I (SI 679-1011)
STR-01, Interface Requirements Document (IRD) - SSM to OTA
ICD-01, Interface Control Document (ICD) - SSM to OTA
STR-02, IRD - SI to OTA and SSM
ICD-02, ICD - Axial SI to OTA/SSM
ICD-03, ICD - Radial SI to OTA/SSM
SD 679-1078, OTA Thermal Control System (TCS)
SN 679-1019, OTA Common Functional Requirements

Primary Mirror Assembly (PMA) ----- LEVEL 2
DWG 679-0204, PMA, Drawing
SN 679-1012, PMA Functional Specification
SB 679-1048, PMA Phase I Requirements
SB 679-1049, PMA Phase II Requirements
SD 679-1092, PMA Design Specification

DWG 679-5796, Central Baffle, Drawing ----- LEVEL 3
SD 679-1061, OTA Baffles, Design Specification
DWG 679-5795, Main Baffle, Drawing
DWG 679-0211, Main Ring Assembly (MRA), Drawing
SD 679-1073, Titanium MRA, Design Specification
DWG 679-0210, Reaction Plate Assembly, Drawing
SD 679-1042, Reaction Plate Design Specification

Figure Control Actuator (FCA) ----- LEVEL 4
DWG 679-0757, FCA Assembly, Drawing
SD 679-1041, FCA Design Specification

Secondary Mirror Assembly (SMA) ----- LEVEL 2
DWG 679-0205, SMA, Drawing
SN 679-1013, SMA Functional Specification
SD 679-1097, SMA Design Specification

Secondary Mirror Sub-Assembly (SMSA) ----- LEVEL 3
DWG 679-0213, SMSA, Drawing
DWG 679-0094, Metering Truss Structure (MTS) Assembly, Drawing
SD 679-1001, MTS Design Specification
DWG 679-5797, Secondary Baffle Assembly, Drawing
SD 679-1061, Secondary Baffle Assembly Design Specification

Small Incremental Motion Actuator (SIMA)----- LEVEL 4
DWG 679-0932, SIMA Assembly (No. 1), Drawing
DWG 679-7857, SIMA Assembly (No. 2), Drawing
DWG 679-7858, SIMA Assembly (No. 3), Drawing
SD 679-1034, SIMA Assembly Design Specification

Focal Plane Assembly (FPA) ----- LEVEL 2
DWG 679-0206, FPA, Drawing
SN 679-1014, FPA, Functional Specification
SN 679-1086, FPA, Design Specification

Focal Plane Structure (FPS) ----- LEVEL 3
DWG 679-0372, FPS, Drawing
SD 679-1055, Flight FPS, Design Specification

DWG 679-0375, Truss Assembly, ----- LEVEL 4
Axial SI Support, Drawing
DWG 679-0374, Deck Assembly, Drawing

Fine Guidance System /
Optical Control Sub-system (FGS/OCS) ----- LEVEL 2
DWG 679-0207, FGS/OCS System Assembly, Drawing
SN 679-1015, FGS, Functional Specification
SN 679-1052, FGS, Design Specification

Star Selector Assembly (SSA) ----- LEVEL 3
DWG 679-5335, SSA, Drawing
SD 679-1030, SSA, Design Specification
DWG 911-3261, FGS Optical Bench Assembly, Drawing
SD 679-1080, FGS Optical Bench, Design Specification
DWG 679-5372, Interferometer Assembly, Drawing
SD 679-1084, Interferometer Assembly, Design Specification

Sensor Electronics Assembly (SEA) ----- LEVEL 4
DWG 679-0660, SEA, Drawing
SD 679-1113, SEA, Design Specification

Optical Control System (OCS) ----- LEVEL 2
DWG 679-0208, OCS Assembly, Drawing
SN 679-1016, OCS, Functional Specification
SN 679-1054, OCS, Design Specification

DWG 679-9777, Window Assembly No. 1, Drawing ----- LEVEL 3
DWG 679-9778, Window Assembly No. 2, Drawing
DWG 679-9789, Modulator Window Assembly No. 3, Drawing
DWG 679-0875, Interferometer Assembly, Drawing
DWG 679-0923, Image Disector Camera Assembly (IDCA), Drawing
SD 679-1081, IDCA, Design Specification
DWG 679-5333, Drive Assembly Mount, Drawing
DWG 679-7854, Test Light Assembly Drawing
DWG 679-5369, OCS Heater and Oven Assembly, Drawing

OTA Equipment Section (OTA ES) ----- LEVEL 2
DWG 679-5780, OTA ES, Drawing

Actuator Control Electronics (ACE) ----- LEVEL 3
DWG 679-0600, ACE Assembly, Drawing
SD 679-1005, ACE, Design Specification

Electrical Power/Thermal Control Electronics (EP/TCE)
DWG 679-0620, EP/TCE Assembly, Drawing
SD 679-1090, EP/TCE, Design Specification

Digital Interface Unit (DIU)
DWG 679-1752, DIU Assembly, Drawing
SD 679-1752, DIU, Design Specification

Optical Control Electronics (OCE)
DWG 679-5408, OCE Assembly, Drawing
SD 679-1007, Design Specification

Fine Guidance Electronics (FGE)
DWG 679-5407, FGE Assembly, Drawing
SD 679-1006, FGE, Design Specification

LMSC/D974197 B
31 May 1985

CREW SYSTEMS DOCUMENT TREE

MODEL: G03305

CONTRACT: NAS 8-32697

REVISED EDITION
MAR 10, 1983

LMSC/D974197B
31 May 1985

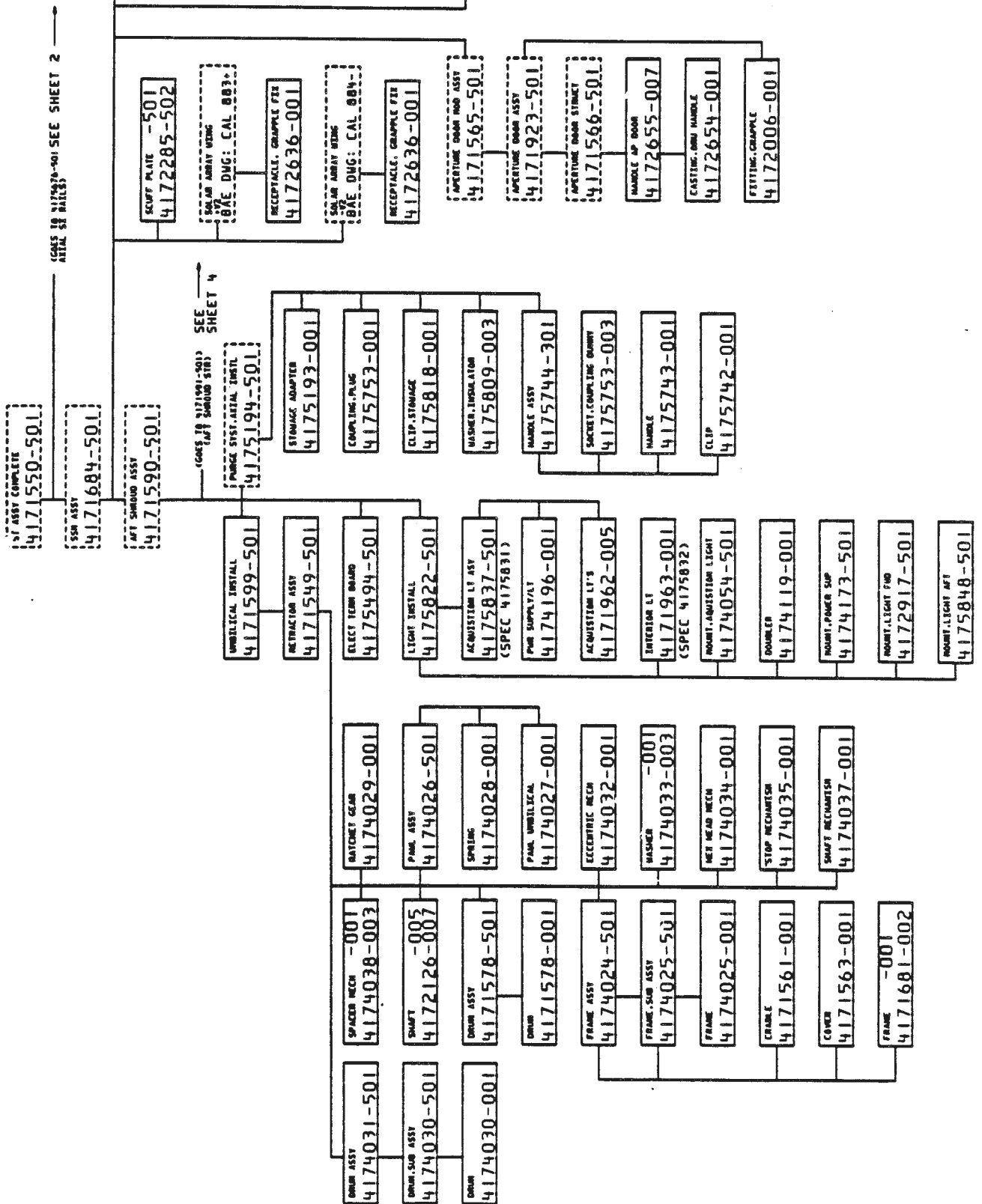

CONT SHEET 3

ST ASSY COMPLETE (REF)
4171550-501

SEE SHEET 1
(GAGE TO 2171900-501
ST ASSY COMPLETE)

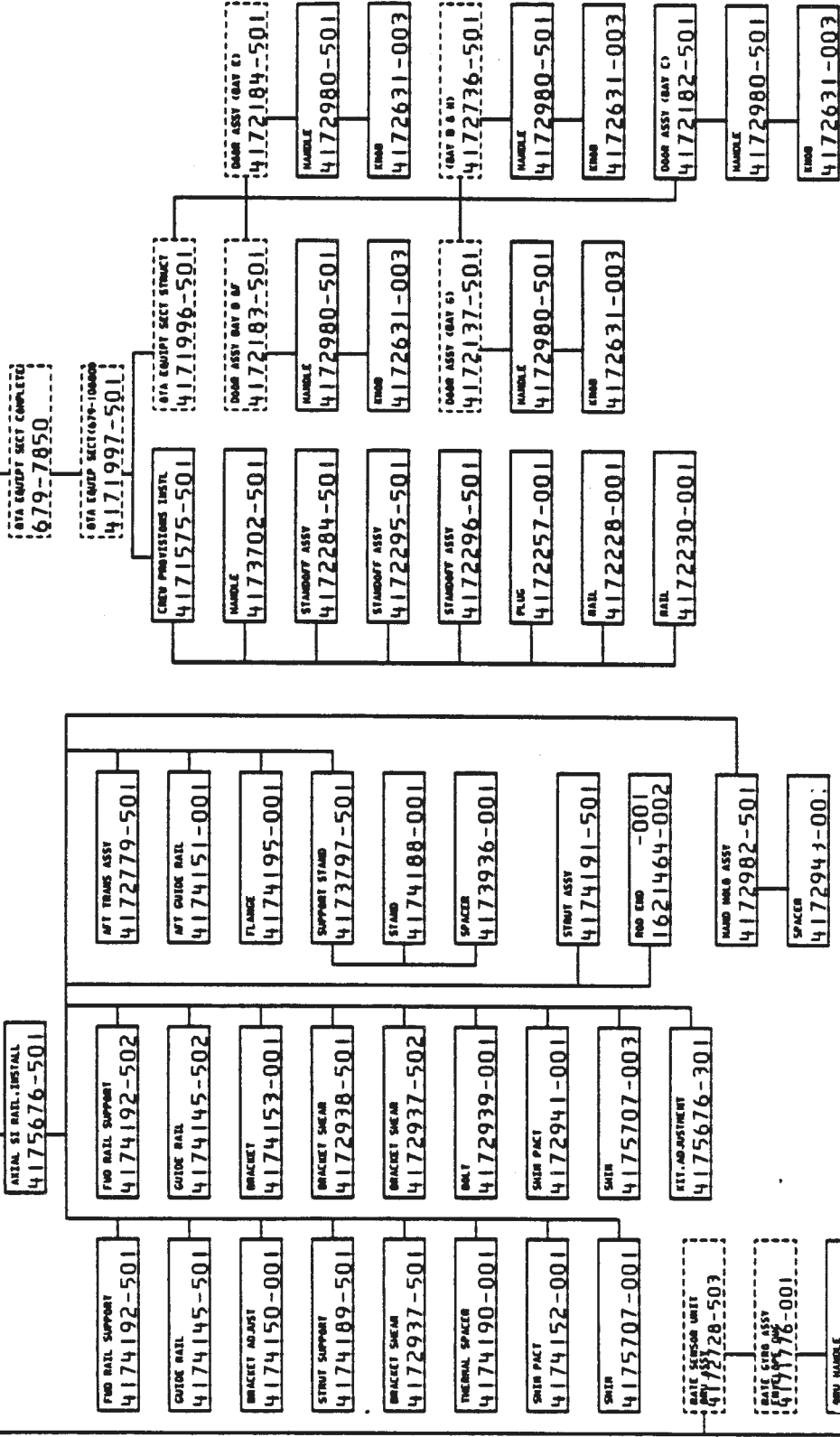

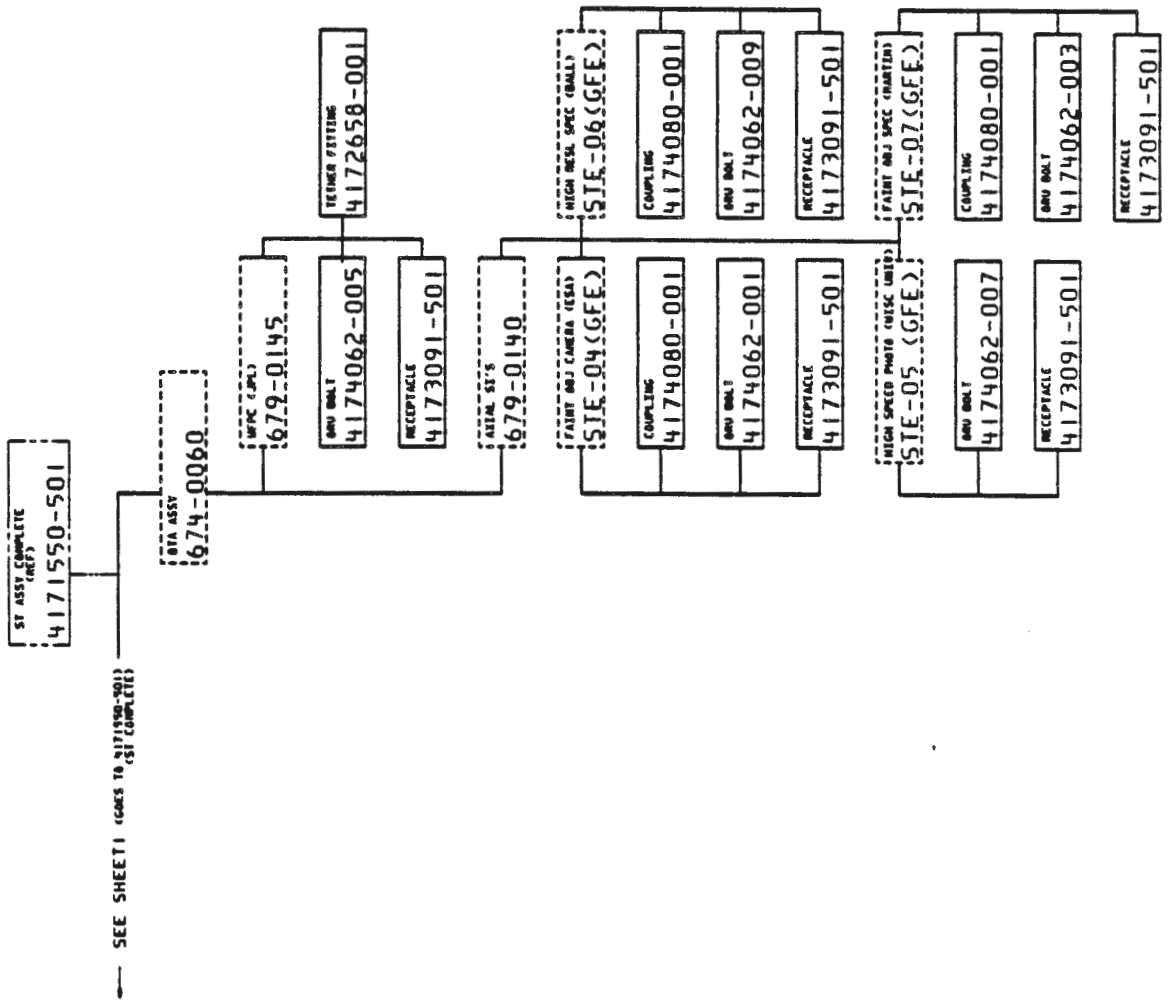

AFT SHROUD ASSY (REF)
4171590-501

SEE SHEET 1 (CHECKS TO 4171590-501)
AFT SHROUD ASSY

FSS LIMB INSTL
4176034

AFT SHROUD STR
4171591-501

SEE SHEET 5
(CHECKS TO 4171591-501)
(CREW AIDS)

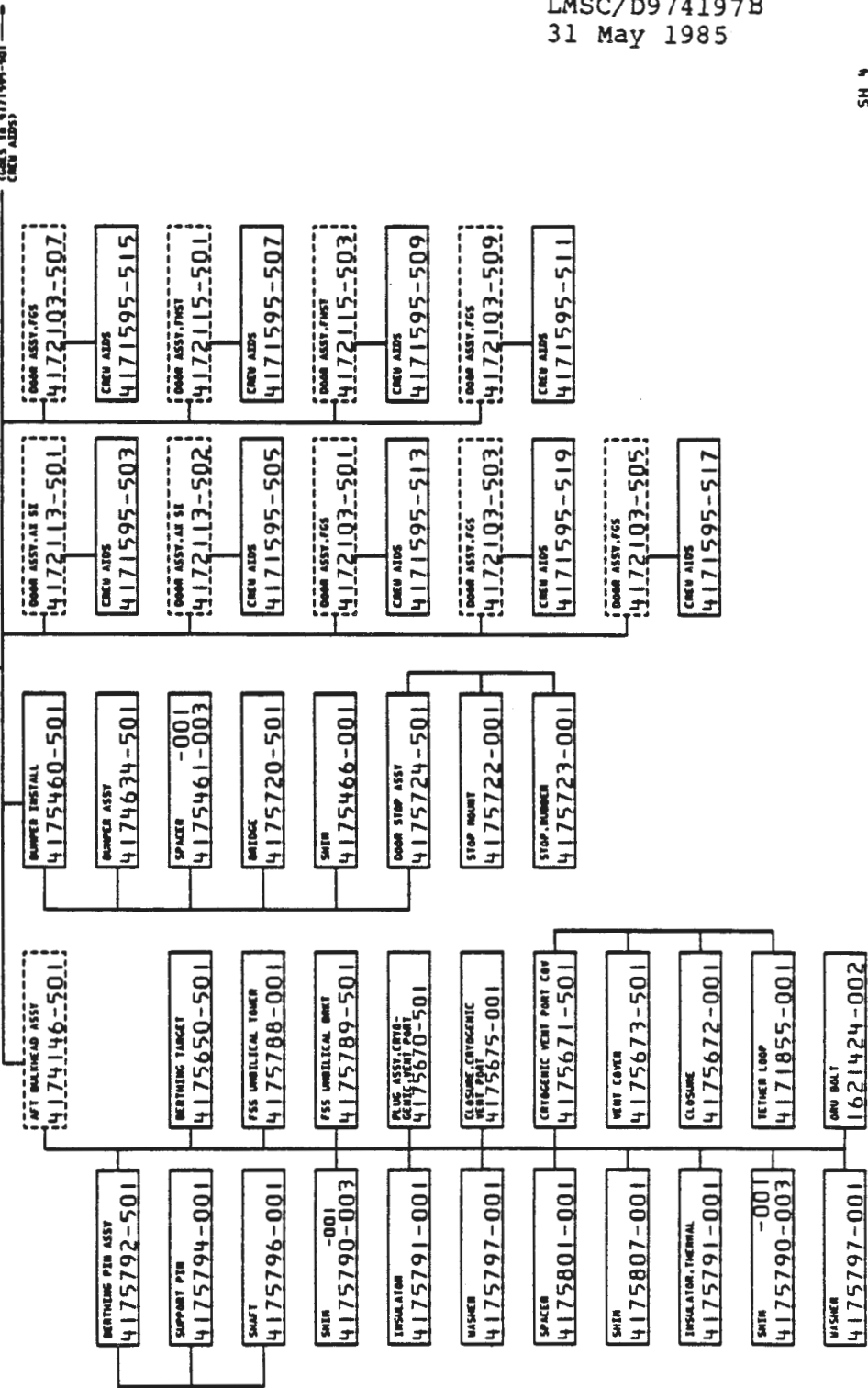

SEE SHEET 4
(Goes to 417191-501)
(AFT SHROUD STRUCTURE)

AFT SHROUD STR (REF)
4171591-501

CREW AIDS
4171595-501

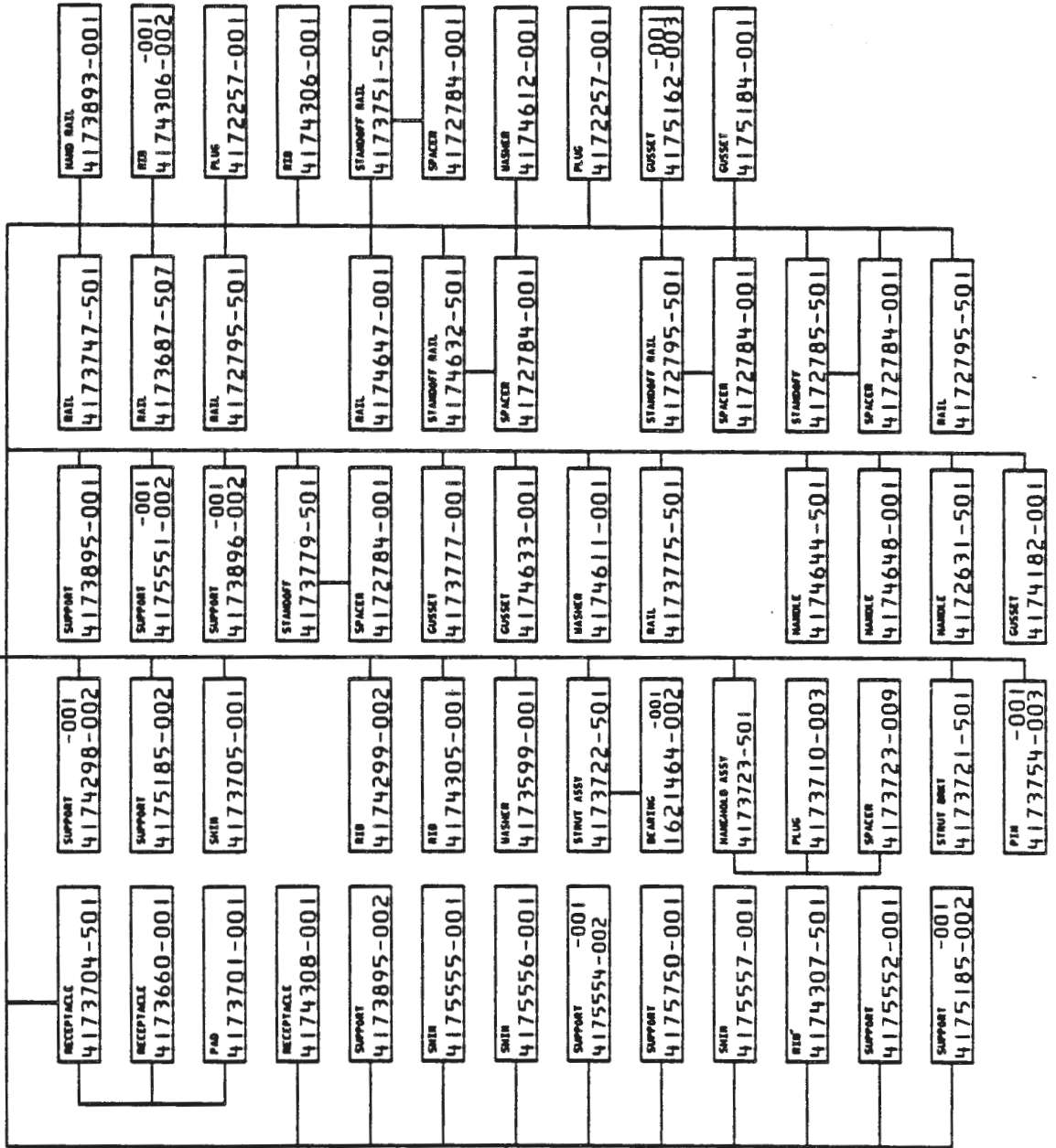

CONT SHEET 7

SSR ASSY COMPLETE
(ENCL)
4171684-501

SEE SHEET 1
(GAS TIGHTING ASSY)

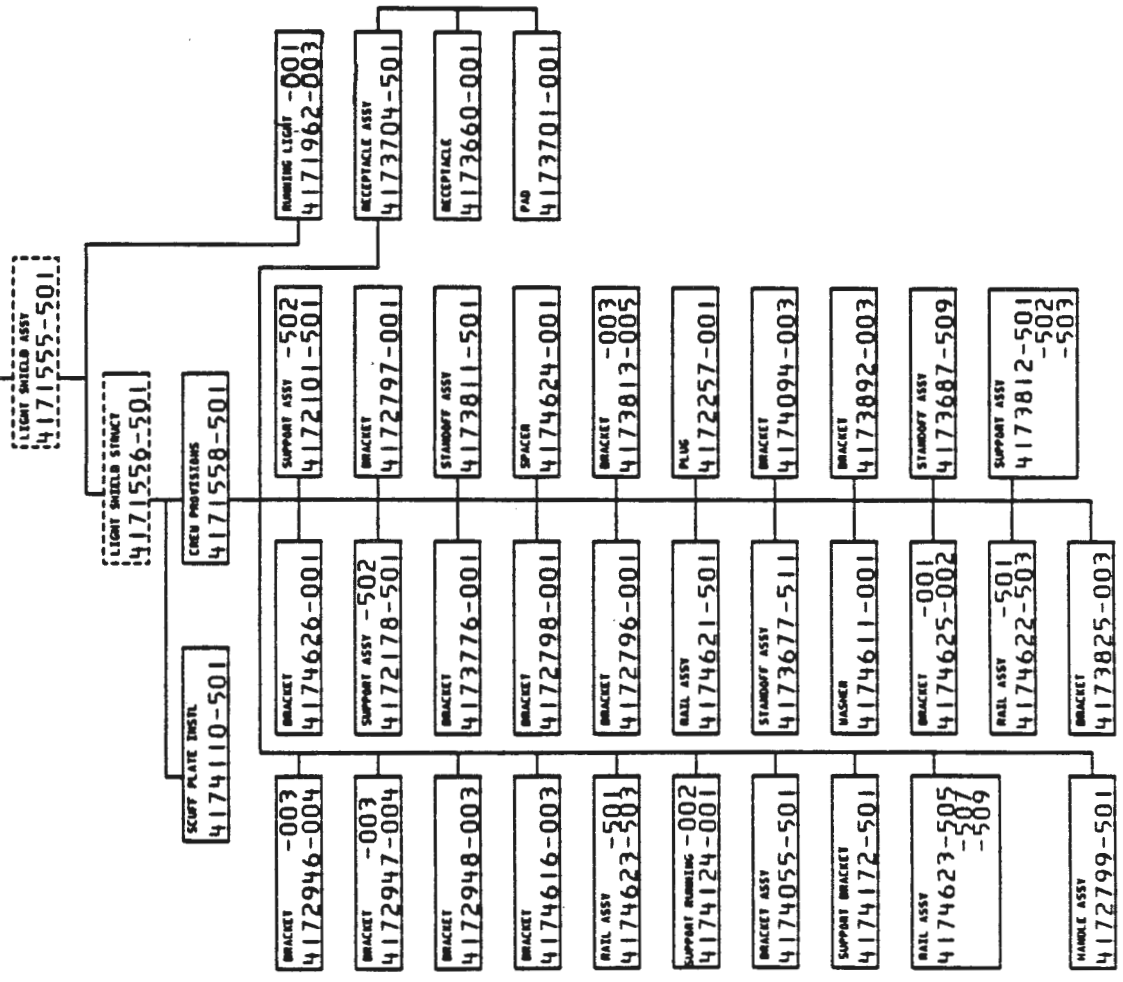

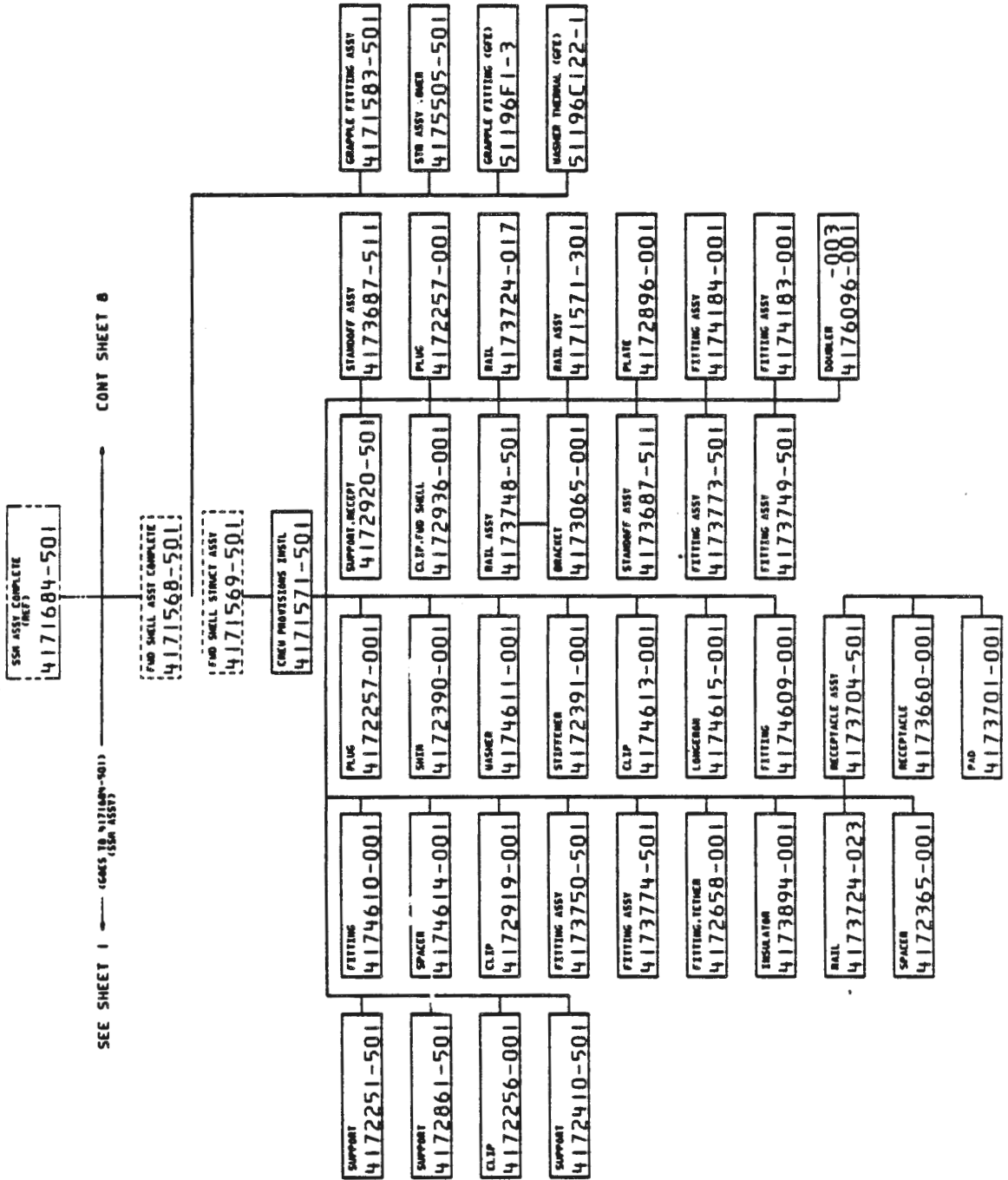

31 May 1985

SH 8

55H ASSY, COMPLETE
4171684-501

SEE SHEET 1
GIVES TO
755H ASSY

EQUIPMENT SECT COMPLETE
4171576-501

EQUIPMENT SECT, STRUCT ASSY
4171577-501

EQUIPMENT SECT, BAY 6
4172352-501

EQUIPMENT SECT, BAY 7
4171585-501

BATTERY, ORU ASSY
4172835-501

4172655-001

CASTING HANDLE,
4172654-001

EQUIPMENT SECT, BAY 8
4172827-501

BATTERY, ORU ASSY
4172835-001

ORU HANDLE
4172655-501

ORU HANDLE, CASTING
4172654-001

DOOR ASSY, BAY 6
4175619-501

HANDLE, DOOR
4172631-501

DOOR ASSY, BAY 7
4172749-501

HANDLE, DOOR
4172631-501

DOOR ASSY, BAY 8
4172758-501

HANDLE, DOOR
4172631-501

DOOR ASSY, BAY 9
4175619-501

HANDLE, DOOR
4172631-501

DOOR ASSY, BAY 10
4172759-501

HANDLE, DOOR
4172631-501

DOOR ASSY, BAY 1
4172743-501

HANDLE, DOOR
4172631-501

DOOR ASSY, BAY 2
4172746-501

HANDLE, DOOR
4172631-501

DOOR ASSY, BAY 9
4172747-501

HANDLE, DOOR
4172631-501

DOOR ASSY, BAY 4
4172757-501

HANDLE, DOOR
4172631-501

DOOR ASSY, BAY 5
4172748-501

HANDLE, DOOR
4172631-501

CASE ASSY
4175669-501

RAIL ASSY
4175669-303

PLUG
4172257-001

HANDRAIL
4174317-007

STANDOFF-ASSY
4174315-501

RAIL ASSY
4175669-304

STANDOFF ASSY
4174130-501

HANDRAIL
4174316-007

PLUG
4172257-001

RAIL ASSY
4175669-307

PLUG
4172257-001

HANDRAIL
4174318-005

STANDOFF
4173687-511

SPACER
4173688-001

STANDOFF
4173677-511

RAIL ASSY
4175669-309

PLUG
4172257-001

HANDRAIL
4174318-007

STANDOFF ASSY
4173687-511

SPACER
4173688-001

STANDOFF
4173677-511

RECEPTACLE ASSY
4173703-501

RECEPTACLE
4173660-001

PAD
4173701-001

WASHER
4174611-001

4171855-001 FETTER
4172650-501 RWA HANDLE

SSE

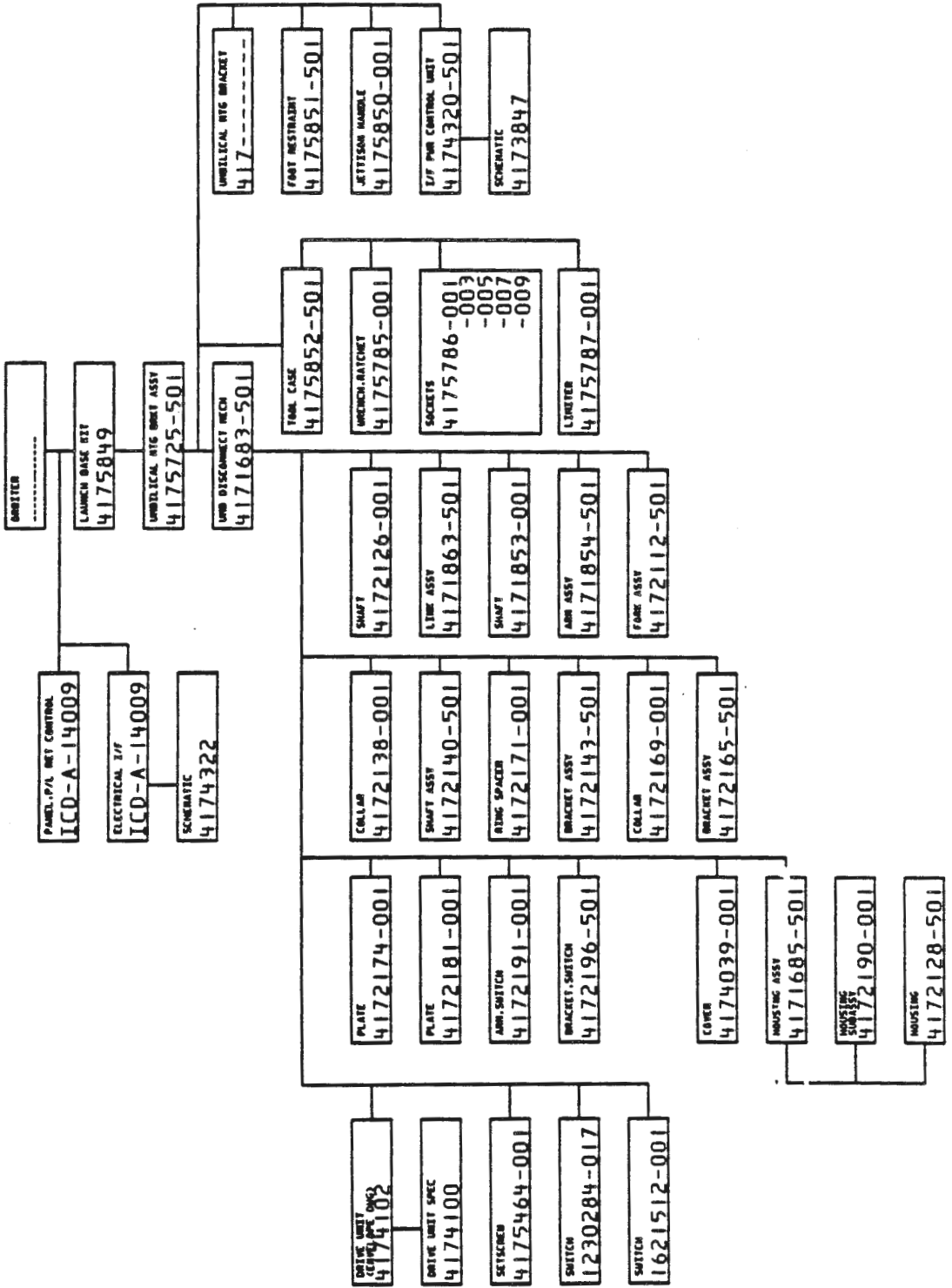

APPENDIX C

ST SCHEMATICS - TABLE of CONTENTS (SE-33)

The ST Schematics Table of Contents, ST/SE-33, (LMSC/D978562A) contain the schematic representation of: (1) ST Power Generation and Control, (2) Power Distribution Interfaces, (3) Data Management System, (4) Data Management System Interfaces, (5) Instrumentation and Communication I/F, (6) Point and Control System; and (7) Safe Mode Computer Configurations.

| SE-33 | | ST EPS SCHEMATICS TABLE OF CONTENTS | | (25 SEP 1984) | |
|--|----|-------------------------------------|----|---------------|----|
| 1 | 2 | 3 | 4 | 5 | 6 |
| <p>1. ST POWER GENERATION & CONTROL</p> <p>1.1 ST POWER BUS CONTROL/DISTRIBUTION</p> <p>1.1.1 ST POWER BUS CONTROL & DISTRIBUTION. 3 SHEETS</p> <p>1.1.2 ORBITER POWER/ESSENTIAL POWER. 2 SHEETS</p> <p>1.1.3 COMMAND/TELEMETRY BUS GENERATION. SM 1 OF 1</p> <p>1.2 ST DIODE BUS POWER GENERATION AND BATTERY CHARGE CONTROL</p> <p>1.2.1 ST DIODE BUS POWER GENERATION AND BATTERY CHARGE CONTROL (BATTERY #1). 2 SHEETS</p> <p>1.2.2 ST DIODE BUS POWER GENERATION AND BATTERY CHARGE CONTROL (BATTERY #2). 2 SHEETS</p> <p>1.2.3 ST DIODE BUS POWER GENERATION AND BATTERY CHARGE CONTROL (BATTERY #3). 2 SHEETS</p> <p>1.2.4 ST DIODE BUS POWER GENERATION AND BATTERY CHARGE CONTROL (BATTERY #4). 2 SHEETS</p> <p>1.2.5 ST DIODE BUS POWER GENERATION AND BATTERY CHARGE CONTROL (BATTERY #5). 2 SHEETS</p> <p>1.2.6 ST DIODE BUS POWER GENERATION AND BATTERY CHARGE CONTROL (BATTERY #6). 2 SHEETS</p> <p>1.3 SSM POWER GENERATION/CONTROL SUBSYSTEM</p> <p>1.3.1 SOLAR ARRAY PANEL ASSEMBLIES. SM 1 OF 1</p> <p>1.3.2 BATTERY 1/PCU/CCC NO.1. 2 SHEETS</p> <p>1.3.3 BATTERY 2/PCU/CCC NO.2. 2 SHEETS</p> <p>1.3.4 BATTERY 3/PCU/CCC NO.3. 2 SHEETS</p> <p>1.3.5 BATTERY 4/PCU/CCC NO.4. 2 SHEETS</p> <p>1.3.6 BATTERY 5/PCU/CCC NO.5. 2 SHEETS</p> <p>1.3.7 BATTERY 6/PCU/CCC NO.6. 2 SHEETS</p> <p>1.3.8 BATTERY HEATERS. 2 SHEETS</p> <p>1.3.9 SA/DB DIRECT I/F. SM 1 OF 1</p> <p>1.3.10 PRIMARY POWER CONTROL. SM 1 OF 1</p> <p>1.3.11 ORBITER POWER FEED & ESSENTIAL BUS CONTROL. SM 1 OF 1</p> <p>1.3.12 MAIN BUS/DIODE BUS SWITCHING. SM 1 OF 1</p> | | | | | |
| 7 | 8 | 9 | 10 | 11 | 12 |
| <p>2. POWER DISTRIBUTION INTERFACES</p> <p>2.1 ORU/DIU POWER I/F</p> <p>2.1.1 ORU POWER INTERFACE. 2 SHEETS</p> <p>2.1.2 DF22N COMPUTER POWER INTERFACE. SM 1 OF 1</p> <p>2.1.3 DF22N COMPUTER MIRS. BAY 4 DOOR MIRS. SM 1 OF 1</p> <p>2.1.4 DIU POWER INTERFACE. 9 SHEETS</p> <p>2.2 POINTING AND CONTROL POWER INTERFACES</p> <p>2.2.1 RTE POWER INTERFACES. 2 SHEETS</p> <p>2.2.2 PSEA-SMC POWER INTERFACE. SM 1 OF 1</p> <p>2.2.3 RCA POWER AND MTR INTERFACES. 3 SHEETS</p> <p>2.2.4 RSU SURVIVAL MIRS. 6 SHEETS</p> <p>2.2.5 RNA POWER INTERFACE. 9 SHEETS</p> <p>2.2.6 RNA HEATERS. 2 SHEETS</p> <p>2.2.7 MAGNETOMETER POWER INTERFACE. SM 1 OF 1</p> <p>2.2.8 FMS POWER INTERFACE. 3 SHEETS</p> <p>2.2.9 FMS MIRS. 3 SHEETS</p> <p>2.2.10 PCU POWER INTERFACE. 2 SHEETS</p> <p>2.2.11 LS/PS AIRV/DPLY MIRS. SM 1 OF 1</p> <p>2.2.12 LS/PS OP MIRS. 2 SHEETS</p> | | | | | |
| 13 | 14 | 15 | 16 | 17 | 18 |
| <p>LEGEND</p> <p>DATE DENOTES LATEST CHANGE</p> <p>DATE DENOTES LATEST CHANGE</p> | | | | | |
| <p>ST SCHEMATICS TABLE OF CONTENTS</p> <p>DATE: 25 SEP 1984</p> <p>FILE NO: D974197 B</p> <p>REV: 1</p> <p>BY: [Signature]</p> <p>APP: [Signature]</p> | | | | | |

SE-33
ST EPS SCHEMATICS TABLE OF CONTENTS

| TABLE NO. | TABLE TITLE | FIGURE NUMBER | FIGURE TITLE |
|-----------|---|---------------|--------------|
| 2.3 | INSTRUMENTATION & COMMUNICATION POWER INTERFACES | | |
| 2.3.1 | MA RESPONDER POWER INTERFACE, SH 1 OF 1 | (1.3.13) | |
| 2.3.2 | SA RTR 1 & 2 POWER INTERFACE, SH 1 OF 1 | (1.3.14) | |
| 2.3.3 | GEA 1 & 2 POWER INTERFACE, SH 1 OF 1 | (1.3.15) | |
| 2.3.4 | ICU POWER INTERFACE, 2 SHEETS | (1.3.21) | |
| 2.3.5 | SA RTR 4TRS, ESTR 4TRS, BAY 7 & 8 4TRS. | (2.7.1) | |
| 2.4 | SOLAR ARRAY DEPLOYMENT POWER INTERFACES | | |
| 2.4.1 | DCE POWER INTERFACE, SH 1 OF 1 | (1.3.17) | |
| 2.4.2 | SAD 1 & OLD 1 POWER INTERFACE, SH 1 OF 1 | (1.3.18) | |
| 2.4.3 | SAD 2 & OLD 2 POWER INTERFACE, SH 1 OF 1 | (1.3.19) | |
| 2.4.4 | SADM/PDM 4TRS, BIDE TRAY 4TRS, SDN SURV 4TRS & SW RTVL 4TRS, 2 SHEETS | (2.7.3) | |
| 2.5 | OTA POWER INTERFACE | | |
| 2.5.1 | OTA-EP/ICE POWER INTERFACE, 4 SHEETS | (1.3.7) | |
| 2.5.2 | OTA BUS POWER INTERFACE, 4 SHEETS | (1.3.8) | |
| 2.5.3 | OTA 4TRS, 14 SHEETS | (2.6) | |
| 2.5.4 | EP/ICE BUS/LTL POWER MONITORS, SH 1 OF 1 | | |
| 2.6 | SI & SIC & DH POWER INTERFACES | | |
| 2.6.1 | SI & SIC & DH POWER INTERFACES, 6 SHEETS | (1.3.10) | |
| 2.6.2 | SIC & DH 4TRS, SH 1 OF 1 | (2.7.2) | |

FIGURE NO. 0690
FIGURE TITLE SKAY91

SE-33
ST DMS SCHEMATICS TABLE OF CONTENTS

15 OCTOBER 1984

| SECTION | DESCRIPTION | NO. OF SHEETS | NO. OF FIGS. |
|---------|---|---------------|--------------|
| 3. | DATA MANAGEMENT SYSTEM | | |
| 3.1 | DF224 COMPUTER CONFIGURATION CONTROL | | |
| 3.1.1 | CPU CARD SELECT. 2 SHEETS | 7 | 6 |
| 3.1.2 | I/O CARD & EXT DATA BUS SELECT. 2 SHEETS | 7 | 6 |
| 3.1.3 | I/O CARD SELECT. 6 SHEETS | 7 | 6 |
| 3.2 | DMU/DF224 COMPUTER EXTERNAL BUS | | |
| 3.2.1 | DMU/DF224 DATA BUS. 6 SHEETS | 7 | 6 |
| 3.2.2 | DMU/DF224 ADDRESS BUS. 2 SHEETS | 7 | 6 |
| 3.2.3 | DMU/DF224 COMPUTER INTERRUPTS & TEMP. MONITORS. SM 1 OF 1 | 7 | 6 |
| 3.2.4 | DMU/DF224 COMPUTER STROBES. 2 SHEETS | 7 | 6 |
| 3.3 | DMU/DIU-TAPE RECORDER | | |
| 3.3.1 | TAPE RECORDER NO.1. 9 SHEETS | 7 | 6 |
| 3.3.2 | TAPE RECORDER NO.2. 9 SHEETS | 7 | 6 |
| 3.3.3 | TAPE RECORDER NO.3. 9 SHEETS | 7 | 6 |
| 3.4 | SYSTEM CLOCK | | |
| 3.4.1 | OSCILLATOR & DMS TIMING. SM 1 OF 1 | 7 | 6 |
| 3.5 | DIU / DMU / DIU X | | |
| 3.5.1 | DIU/DIU X 3/F (POWER ON/OFF 1/F). SM 1 OF 1 | 7 | 6 |
| 3.5.2 | DMU TO DIU1 (DATA) REQUEST/REPLY MESSAGE INTERFACE. SM 1 OF 1 | 7 | 6 |
| 3.5.3 | DMU TO DIU2 REQUEST/REPLY MESSAGE INTERFACE. SM 1 OF 1 | 7 | 6 |
| 3.5.4 | DMU TO DIU3 REQUEST/REPLY MESSAGE INTERFACE. SM 1 OF 1 | 7 | 6 |
| 3.5.5 | DMU TO DIU4 REQUEST/REPLY MESSAGE INTERFACE. SM 1 OF 1 | 7 | 6 |
| 3.5.6 | DMU MESSAGE COMMAND INTERFACE TEST CONNECTOR. SM 1 OF 1 | 7 | 6 |
| 3.6 | DMS-MECHANISM CONTROL UNIT (MCU) | | |
| 3.6.1 | POWER SUPPLY CONTROL COMMANDS. SM 1 OF 1 | 7 | 6 |
| 3.6.2 | SERIAL DIGITAL COMMAND. SM 1 OF 1 | 7 | 6 |
| 3.6.3 | POWER SUPPLY CONTROL COMMANDS. SM 1 OF 1 | 7 | 6 |
| 3.6.4 | MCU SERIAL DIGITAL. 2 SHEETS | 7 | 6 |
| 3.6.5 | APERTURE DOOR HINGES. SM 1 OF 1 | 7 | 6 |
| 3.6.6 | APERTURE DOOR LATCHES. SM 1 OF 1 | 7 | 6 |
| 3.6.7 | SOLAR ARRAY FUD LATCH. 2 SHEETS | 7 | 6 |
| 3.6.8 | SOLAR ARRAY AFF LATCHES. 2 SHEETS | 7 | 6 |
| 3.6.9 | MCA LATCHES. 2 SHEETS | 7 | 6 |
| 3.6.10 | MCA HINGES. 2 SHEETS | 7 | 6 |
| 3.6.11 | MCU TEST CONNECTORS. 6 SHEETS | 7 | 6 |

SE-33
ST DMS SCHEMATICS TABLE OF CONTENTS

15 OCTOBER 1984

| SECTION | DESCRIPTION | SHEETS | FIGURE NO. | FIGURE TITLE | FIGURE NO. | FIGURE TITLE | | | |
|--------------------------------------|-------------|--|------------|--------------|------------|-------------------------------------|--------------------------|------------|--|
| 4. DATA MANAGEMENT SYSTEM INTERFACES | 9.1 OTA | 9 24 | 9 24 | 9.1.1 | (9.1.1) | 9.1.1 DMS-OTA DTU 01 I/F. 2 SHEETS | | | |
| | | | | | | | 9.1.2 | (9.1.2) | 9.1.2 DTU TO OTA TIEING INTERFACE. 2 SHEETS |
| | | | | | | | 9.1.3 | | 9.1.3 PRIMARY AND SECONDARY MIRRORS ACTUATOR POSITION DATA INTERFACE. 6 SHEETS |
| | | | | | | | 9.1.4 | | 9.1.4 SEE DATA INTERFACES. SM 1 OF 1 |
| 9.2 DTU / SI CDDH | 9 24 | 9 24 | 9.2.1 | (9.2.1) | (9.2.1) | 9.2.1 SI CDDH / SSM DMS. SM 1 OF 1 | | | |
| | | | | | | | 9.2.2 | (9.2.2) | 9.2.2 DTU/SI CDDH 27 BIT SERIAL CMD. SM 1 OF 1 |
| | | | | | | | 9.2.3 | (9.2.3) | 9.2.3 DTU/SI CDDH EYS TLR I/F. 3 SHEETS |
| | | | | | | | 9.2.4 | (9.2.4) | 9.2.4 1.024 MHZ 8 BIT I/F. SM 1 OF 1 |
| | | | | | | | 9.2.5 | (9.2.5) | 9.2.5 DTU/SI CDDH PIT I/F. SM 1 OF 1 |
| | | | | | | | 9.2.6 | (9.2.6) | 9.2.6 DTU/SI CDDH 16 BIT CMD. SM 1 OF 1 |
| | | | | | | | 9.2.7 | (9.2.7) | 9.2.7 DTU 1/SI CDDH SCIENCE I/F. SM 1 OF 1 |
| | | | | | | | 9.2.8 | (9.2.8) | 9.2.8 DTU/SI CDDH/SI CURRENT MONITORS. 6 SHEETS |
| | | | | | | | 9.2.9 | (9.2.9) | 9.2.9 SI CDDH TO SI SCIENCE DATA I/F. 5 SHEETS |
| 9.3 DEPLOYMENT CONTROL ELECTRONICS | 9 24 | 9 24 | 9.3.1 | (9.3.1) | (9.3.1) | 9.3.1 MOTOR CONTROL. 2 SHEETS | | | |
| | | | | | | | 9.3.2 | (9.3.2) | 9.3.2 INTERNAL STATUS. SM 1 OF 1 |
| | | | | | | | 9.3.3 | (9.3.3) | 9.3.3 WING DEPLOYMENT MONITORS. 3 SHEETS |
| | | | | | | | 9.3.4 | (9.3.4) | 9.3.4 WING TENSION 8 TEMP MONITORS. 2 SHEETS |
| | | | | | | | 9.3.5 | (9.3.5) | 9.3.5 WING ACTUATOR TEMP MONITORS. 2 SHEETS |
| | | | | | | | 9.3.6 | (9.3.6) | 9.3.6 DCE POWER CONTROL. SM 1 OF 1 |
| | | | | | | | 9.3.7 | (9.3.7) | 9.3.7 SOLAR ARRAY 540W TEMPERATURE MONITORS. SM 1 OF 1 |
| 9.4 SOLAR ARRAY DRIVE ELECTRONICS | 9 24 | 9 24 | 9.4.1 | (9.4.1) | (9.4.1) | 9.4.1 SOLAR ARRAY DRIVE ELECTRONICS | | | |
| | | | | | | | 9.4.1.1 | (9.4.1.1) | 9.4.1.1 SADE OFF LOAD DEVICE. 2 SHEETS |
| | | | | | | | 9.4.1.2 | (9.4.1.2) | 9.4.1.2 SA WING CONTROL. 4 SHEETS |
| | | | | | | | 9.4.1.3 | (9.4.1.3) | 9.4.1.3 SADE 8 WING DATA. 2 SHEETS |
| | | | | | | | 9.4.1.4 | (9.4.1.4) | 9.4.1.4 SADE 8 WING DATA. 2 SHEETS |
| | | | | | | | 9.4.1.5 | (9.4.1.5) | 9.4.1.5 SADE 8 WING DATA. 2 SHEETS |
| | | | | | | | 9.4.1.6 | (9.4.1.6) | 9.4.1.6 SADE 8 WING DATA. 2 SHEETS |
| | | | | | | | 9.4.1.7 | (9.4.1.7) | 9.4.1.7 SADE 8 WING DATA. 2 SHEETS |
| | | | | | | | 9.4.1.8 | (9.4.1.8) | 9.4.1.8 SADE 8 WING DATA. 2 SHEETS |
| | | | | | | | 9.4.1.9 | (9.4.1.9) | 9.4.1.9 SADE 8 WING DATA. 2 SHEETS |
| | | | | | | | 9.4.1.10 | (9.4.1.10) | 9.4.1.10 SADE 8 WING DATA. 2 SHEETS |
| | | | | | | | 9.4.1.11 | (9.4.1.11) | 9.4.1.11 SADE 8 WING DATA. 2 SHEETS |
| | | | | | | | 9.4.1.12 | (9.4.1.12) | 9.4.1.12 SADE 8 WING DATA. 2 SHEETS |
| | | | | | | | 9.4.1.13 | (9.4.1.13) | 9.4.1.13 SADE 8 WING DATA. 2 SHEETS |
| | | | | | | | 9.4.1.14 | (9.4.1.14) | 9.4.1.14 SADE 8 WING DATA. 2 SHEETS |
| | | | | | | | 9.4.1.15 | (9.4.1.15) | 9.4.1.15 SADE 8 WING DATA. 2 SHEETS |
| 9.5 MGA | 9 24 | 9 24 | 9.5.1 | (9.5.1) | (9.5.1) | 9.5.1 MGA POWER. 2 SHEETS | | | |
| | | | | | | | 9.5.2 | (9.5.2) | 9.5.2 MGA INHIBIT CIRCUITS. 2 SHEETS |
| | | | | | | | 9.5.3 | (9.5.3) | 9.5.3 MGA COMMAND SYSTEM. 4 SHEETS |
| | | | | | | | 9.5.4 | (9.5.4) | 9.5.4 MGA TELEMETRY. 4 SHEETS |
| | | | | | | | 9.5.5 | (9.5.5) | 9.5.5 MGA CLOCK SYSTEM. 2 SHEETS |
| | | | | | | | 9.5.6 | (9.5.6) | 9.5.6 MGA CLOCK SYSTEM. 2 SHEETS |
| | | | | | | | 9.5.7 | (9.5.7) | 9.5.7 MGA CLOCK SYSTEM. 2 SHEETS |
| | | | | | | | 9.5.8 | (9.5.8) | 9.5.8 MGA CLOCK SYSTEM. 2 SHEETS |
| | | | | | | | 9.5.9 | (9.5.9) | 9.5.9 MGA CLOCK SYSTEM. 2 SHEETS |
| | | | | | | | 9.5.10 | (9.5.10) | 9.5.10 MGA CLOCK SYSTEM. 2 SHEETS |
| | | | | | | | 9.5.11 | (9.5.11) | 9.5.11 MGA CLOCK SYSTEM. 2 SHEETS |
| | | | | | | | 9.5.12 | (9.5.12) | 9.5.12 MGA CLOCK SYSTEM. 2 SHEETS |
| | | | | | | | 9.5.13 | (9.5.13) | 9.5.13 MGA CLOCK SYSTEM. 2 SHEETS |
| | | | | | | | 9.5.14 | (9.5.14) | 9.5.14 MGA CLOCK SYSTEM. 2 SHEETS |
| | | | | | | | 9.5.15 | (9.5.15) | 9.5.15 MGA CLOCK SYSTEM. 2 SHEETS |
| | | | | | | | 9.6 TEMPERATURE MONITORS | 9 24 | 9 24 |
| 9.6.2 | (9.6.2) | 9.6.2 MGA HINGE/LATCH TEMP MONITORS. SM 1 OF 1 | | | | | | | |
| 9.6.3 | (9.6.3) | 9.6.3 SOLAR ARRAY LATCH TEMP MONITORS. SM 1 OF 1 | | | | | | | |
| 9.6.4 | (9.6.4) | 9.6.4 LIGHT SHIELD/FORWARD SHELL TEMP MONITORS. 2 SHEETS | | | | | | | |
| 9.6.5 | (9.6.5) | 9.6.5 EQUIP BAYS, BOARDS, AND OTHER STRUCTURAL TEMP MONITORS. (2.0.5) 9 SHEETS | | | | | | | |
| 9.6.6 | (9.6.6) | 9.6.6 OTA STRUCTURAL TEMP MONITORS. SM 1 OF 1 | | | | | | | |
| 9.6.7 | (9.6.7) | 9.6.7 AFF SHROUD TEMP MONITORS. 3 SHEETS | | | | | | | |
| 9.6.8 | (9.6.8) | 9.6.8 DRU/WSS TEMP MONITORS. SM 1 OF 1 | | | | | | | |
| 9.6.9 | (9.6.9) | 9.6.9 MA ENTR P.A./ASC TEMP MONITORS. SM 1 OF 1 | | | | | | | |
| 9.6.10 | (9.6.10) | 9.6.10 DTU TEMP MONITORS. SM 1 OF 1 | | | | | | | |
| 9.6.11 | (9.6.11) | 9.6.11 FGS TEMP MONITORS. 3 SHEETS | | | | | | | |
| 9.6.12 | (9.6.12) | 9.6.12 OTA EQUIP. SECTION TEMP MONITORS. SM 1 OF 1 | | | | | | | |
| 9.6.13 | (9.6.13) | 9.6.13 OTA FACIAL PLANE TEMP MONITORS. 3 SHEETS | | | | | | | |
| 9.6.14 | (9.6.14) | 9.6.14 OTA MAIN RING TEMP MONITORS. SM 1 OF 1 | | | | | | | |
| 9.6.15 | (9.6.15) | 9.6.15 OTA PRIMARY MIRROR TEMP MONITORS. SM 1 OF 1 | | | | | | | |
| 9.6.16 | (9.6.16) | 9.6.16 OTA SECONDARY MIRROR TEMP MONITORS. SM 1 OF 1 | | | | | | | |

SE-33
ST DMS SCHEMATICS TABLE OF CONTENTS

| SECTION | DESCRIPTION | FIG. NO. NUMBER | START DATE | END DATE | FIG. NO. NUMBER | START DATE | END DATE | |
|--|---|--|--|-------------------------------|--|--------------------------------------|----------|--------|
| 5. INSTRUMENTATION & COMMUNICATION I/F | 5.1 RF SWITCHING | 5.1.1 RF SWITCHING HGA/LGA I/F, SH 1 OF 1 | 7/10 | 7/10 | 49.1.1 | 7/10 | 7/10 | |
| | | 5.2 MA TRANSpondERS | 7/10 | 7/10 | 49.2.1 | 7/10 | 7/10 | |
| | 5.2.1 MA SPONDER CONTROL, 2 SHEETS | 5.2.2 MA SPONDER MONITORS, 3 SHEETS | 7/10 | 7/10 | 49.2.2 | 7/10 | 7/10 | |
| | | 5.2.3 MA SPONDER-DPU RF I/F, 2 SHEETS | 7/10 | 7/10 | 49.2.3 | 7/10 | 7/10 | |
| | | 5.3 S BAND SINGLE ACCESS TRANSMITTERS | 5.3.1 SA XMT/R RF PUR & TEMP MONITORS, SH 1 OF 1 | 7/10 | 7/10 | 49.3.1 | 7/10 | 7/10 |
| | 5.3.2 SA XMT/R/DPU RF I/F, SH 1 OF 1 | | 7/10 | 7/10 | 49.3.2 | 7/10 | 7/10 | |
| | 6. POINTING & CONTROL SYSTEM | 6.1 RATE GYRO ASSEMBLY INTERFACES | 6.1.1 | 7/10 | 7/10 | DELETED (REPLACED BY 6.1.5 - 6.1.10) | | |
| | | | 6.1.2 | 7/10 | 7/10 | | | |
| | | | 6.1.3 | 7/10 | 7/10 | | | |
| | | | 6.1.4 | 7/10 | 7/10 | | | |
| 6.1.5 RGA NO.1 SUBSYSTEM CM 1 RSU 1-1, 5 SHEETS | | | 7/10 | 7/10 | | | | |
| 6.1.6 RGA NO.1 SUBSYSTEM CM 2 RSU 1-2, 5 SHEETS | | | 7/10 | 7/10 | | | | |
| 6.1.7 RGA NO.2 SUBSYSTEM CM 1 RSU 2-1, 3 SHEETS | | | 7/10 | 7/10 | | | | |
| 6.1.8 RGA NO.2 SUBSYSTEM CM 2 RSU 2-2, 3 SHEETS | | | 7/10 | 7/10 | | | | |
| 6.1.9 RGA NO.3 SUBSYSTEM CM 1 RSU 3-1, 3 SHEETS | | | 7/10 | 7/10 | | | | |
| 6.1.10 RGA NO.3 SUBSYSTEM CM 2 RSU 3-2, 3 SHEETS | | | 7/10 | 7/10 | | | | |
| 6.2 FIXED HEAD STAR TRACKER | 6.2.1 DNU/FHST I/F DIGITAL, 3 SHEETS | 6.2.2 DNU/FHST I/F ANALOG, 3 SHEETS | 7/10 | 7/10 | 49.1.1 | 7/10 | 7/10 | |
| | | 6.3 FINE GUIDANCE ELECTRONICS | 6.3.1 FGS - STAR SELECTOR SERVO, 3 SHEETS | 7/10 | | | | 7/10 |
| | 6.3.2 FGS - INTERFEROMETER, 3 SHEETS | | 7/10 | 7/10 | 49.2.2 | 7/10 | 7/10 | |
| | 6.3.3 FGS - FILTER WHEEL, 3 SHEETS | | 7/10 | 7/10 | 49.2.3 | 7/10 | 7/10 | |
| | 6.3.4 OPTICAL CONTROL SUBSYSTEM WAY FROM SENSORS, 2 SHEETS | 6.3.5 PRIMARY AND SECONDARY MIRRORS ACTUATOR POSITION DATA INTERFACE, 6 SHEETS | 6.4 COARSE SUN SENSOR SUBSYSTEM | 6.4.1 CSS/PSEA, 6 SHEETS | 7/10 | 7/10 | 49.4.1 | 7/10 |
| | | | | 6.5 MAGNETIC SENSOR SUBSYSTEM | 6.5.1 MAGNETIC SENSOR SYSTEM, 2 SHEETS | 7/10 | 7/10 | 49.5.1 |
| | 6.5.2 GRAVITY GRADIENT MODE INITIATE (COMMANDED), SH 1 OF 1 | 7/10 | 7/10 | | 49.5.2 | 7/10 | 7/10 | |
| | 6.6 REACTION WHEEL | 6.6.1 REACTION WHEEL ASSY 1, 6 SHEETS | 7/10 | 7/10 | 49.6.1 | 7/10 | 7/10 | |
| | | 6.6.2 REACTION WHEEL ASSY 2, 6 SHEETS | 7/10 | 7/10 | 49.6.2 | 7/10 | 7/10 | |
| | | 6.6.3 REACTION WHEEL ASSY 3, 6 SHEETS | 7/10 | 7/10 | 49.6.3 | 7/10 | 7/10 | |
| 6.6.4 REACTION WHEEL ASSY 4, 6 SHEETS | | 7/10 | 7/10 | 49.6.4 | 7/10 | 7/10 | | |

15 OCTOBER 1984

SE-33
ST DMS SCHEMATICS TABLE OF CONTENTS

15 OCTOBER 1984

| | | |
|-------|--|---------|
| 6.7 | MAGNETIC TORQUER (PSCA I/F) | |
| 6.7.1 | MAGNETIC TORQUER SUBSYSTEM NO.1. 2 SHEETS | (6.7.1) |
| 6.7.2 | MAGNETIC TORQUER SUBSYSTEM NO.2. 2 SHEETS | (6.7.2) |
| 6.7.3 | MAGNETIC TORQUER SUBSYSTEM NO.3. 2 SHEETS | (6.7.3) |
| 6.7.4 | MAGNETIC TORQUER SUBSYSTEM NO.4. 2 SHEETS | (6.7.4) |
| 7. | SAFE MODE COMPUTER CONFIGURATIONS | |
| 7.1 | KEEP ALIVE / INITIATE | |
| 7.1.1 | SAFE MODE POWER UP & KEEP ALIVE SIGNAL PROCESSING (A SIDE). 4 SHEETS | (7.1.1) |
| 7.1.2 | SAFE MODE POWER UP & KEEP ALIVE SIGNAL PROCESSING (B SIDE). 4 SHEETS | (7.1.2) |
| 7.1.3 | MEMORY LOAD/SERIAL DATA OUT (A SIDE). 2 SHEETS | (7.1.3) |
| 7.1.4 | MEMORY LOAD/SERIAL DATA OUT (B SIDE). 2 SHEETS | (7.1.4) |
| 7.2 | RETRIEVAL NODE CYRO. ASSY. | |
| 7.2.1 | RMCA INTERFACE. SH 1 OF 1 | (7.2.1) |
| 7.3 | SMCA | |
| 7.3.1 | SAFE MODE COMPUTER (A). SMCA. 3 SHEETS | (7.3.1) |

15-00 (REV. 2)

15-00 (REV. 2)

PAGE 6

15-00 (REV. 2)
E 0088 / 586491

LMSC/D974197B
31 May 1985

APPENDIX D
SPACE TELESCOPE CONFIGURATION DRAWINGS
INBOARD/OUTBOARD PROFILE
(Six Charts)

LMSC/D974197B
31 May 1985

| REVISIONS | | | |
|-----------|-----|------------------------|----------|
| ZONE | REV | DESCRIPTION | DATE |
| | A | NO CHANGE NOT RELEASED | 11 17 85 |

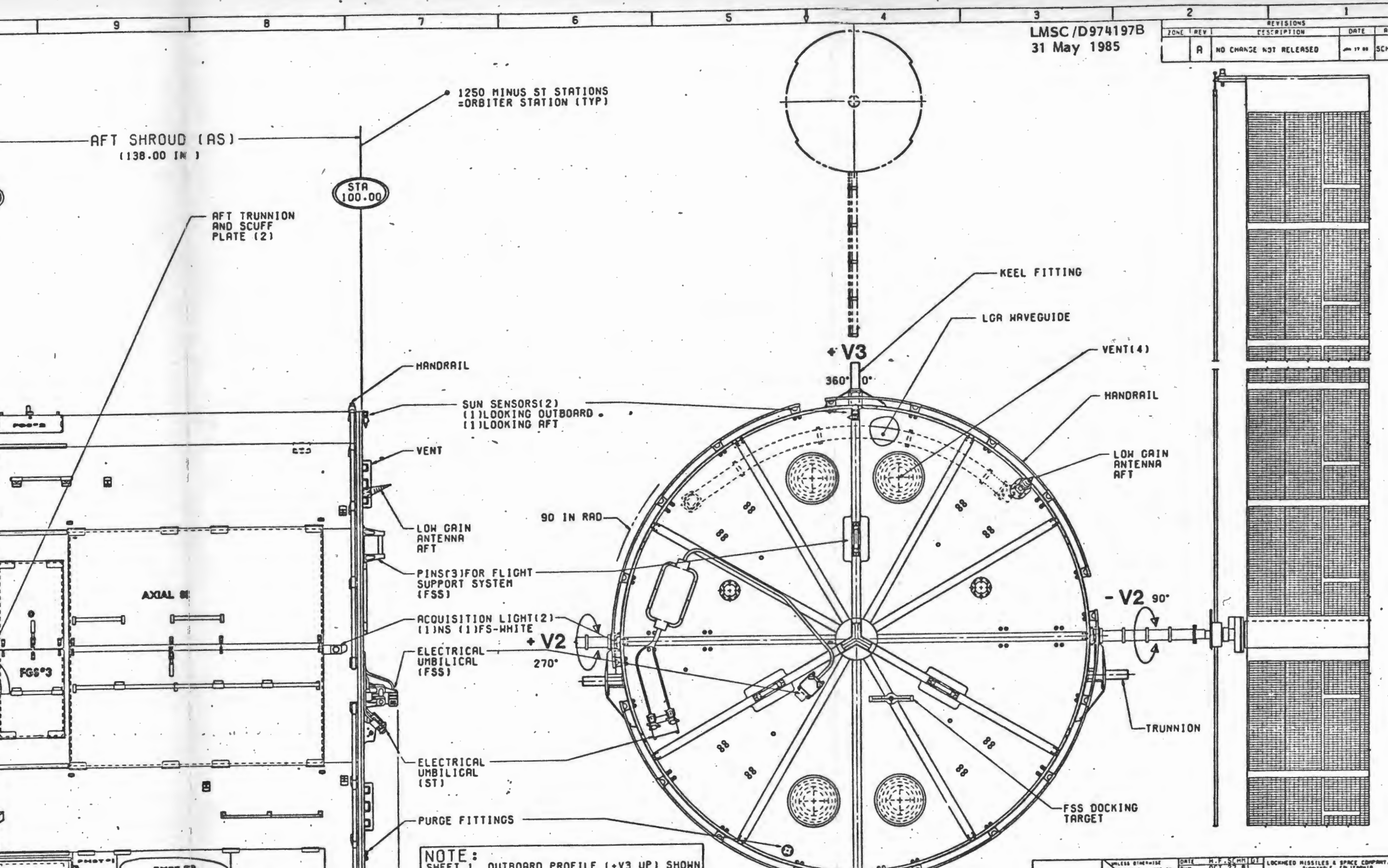

AFT SHROUD (AS)
(138.00 IN)

STA
100.00

AFT TRUNNION
AND SCUFF
PLATE (2)

1250 MINUS ST STATIONS
=ORBITER STATION (TYP)

HANDRAIL

SUN SENSORS (2)
(1) LOOKING OUTBOARD
(1) LOOKING AFT

VENT

LOW GAIN
ANTENNA
AFT

PINS (3) FOR FLIGHT
SUPPORT SYSTEM
(FSS)

ACQUISITION LIGHT (2)
(1) INS (1) FS-WHITE

ELECTRICAL
UMBILICAL
(FSS)

ELECTRICAL
UMBILICAL
(ST)

PURGE FITTINGS

KEEL FITTING

LGA WAVEGUIDE

VENT (4)

HANDRAIL

LOW GAIN
ANTENNA
AFT

-V2 90°

TRUNNION

FSS DOCKING
TARGET

NOTE:
SHEET 1 OUTBOARD PROFILE (+V3 UP) SHOWN

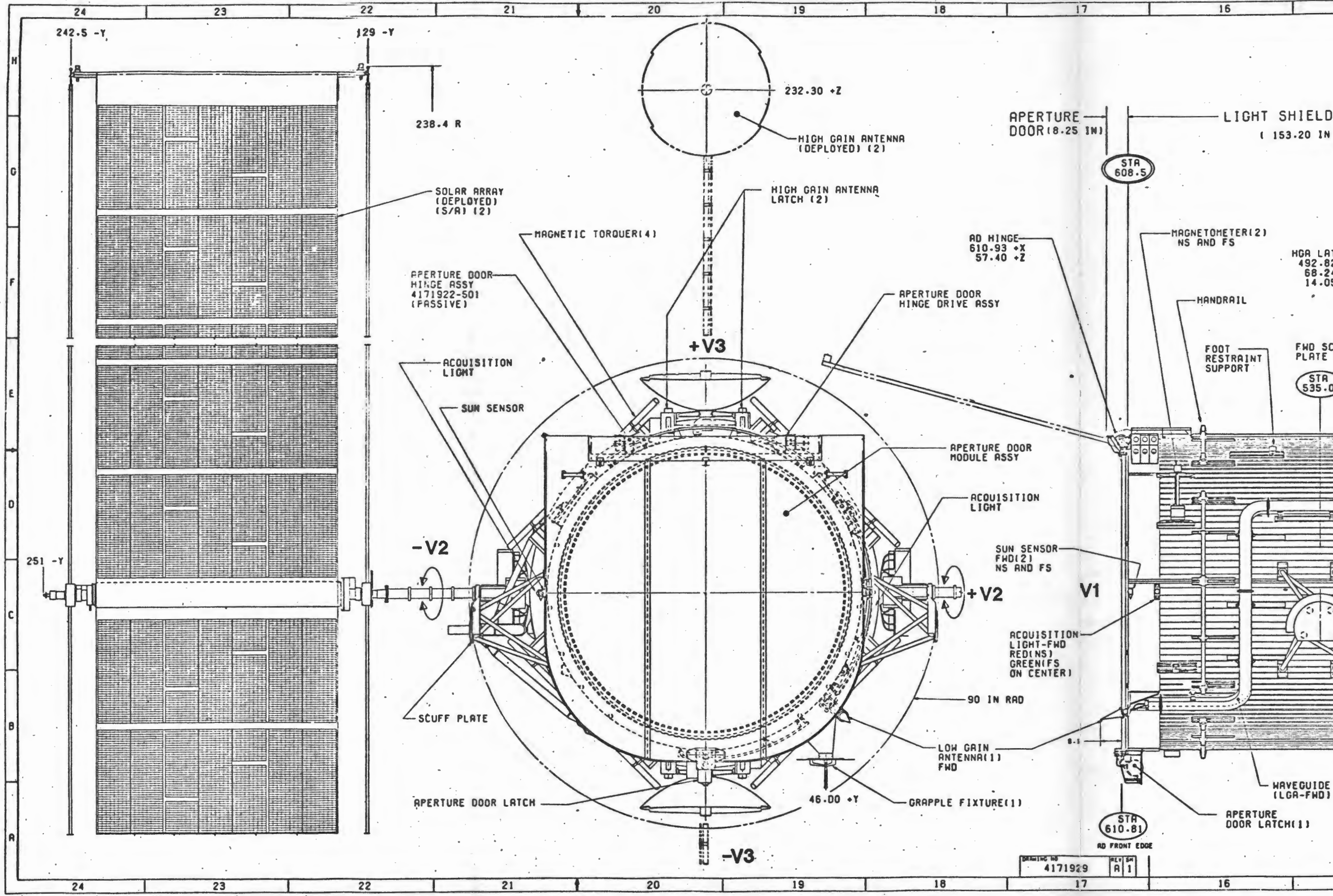

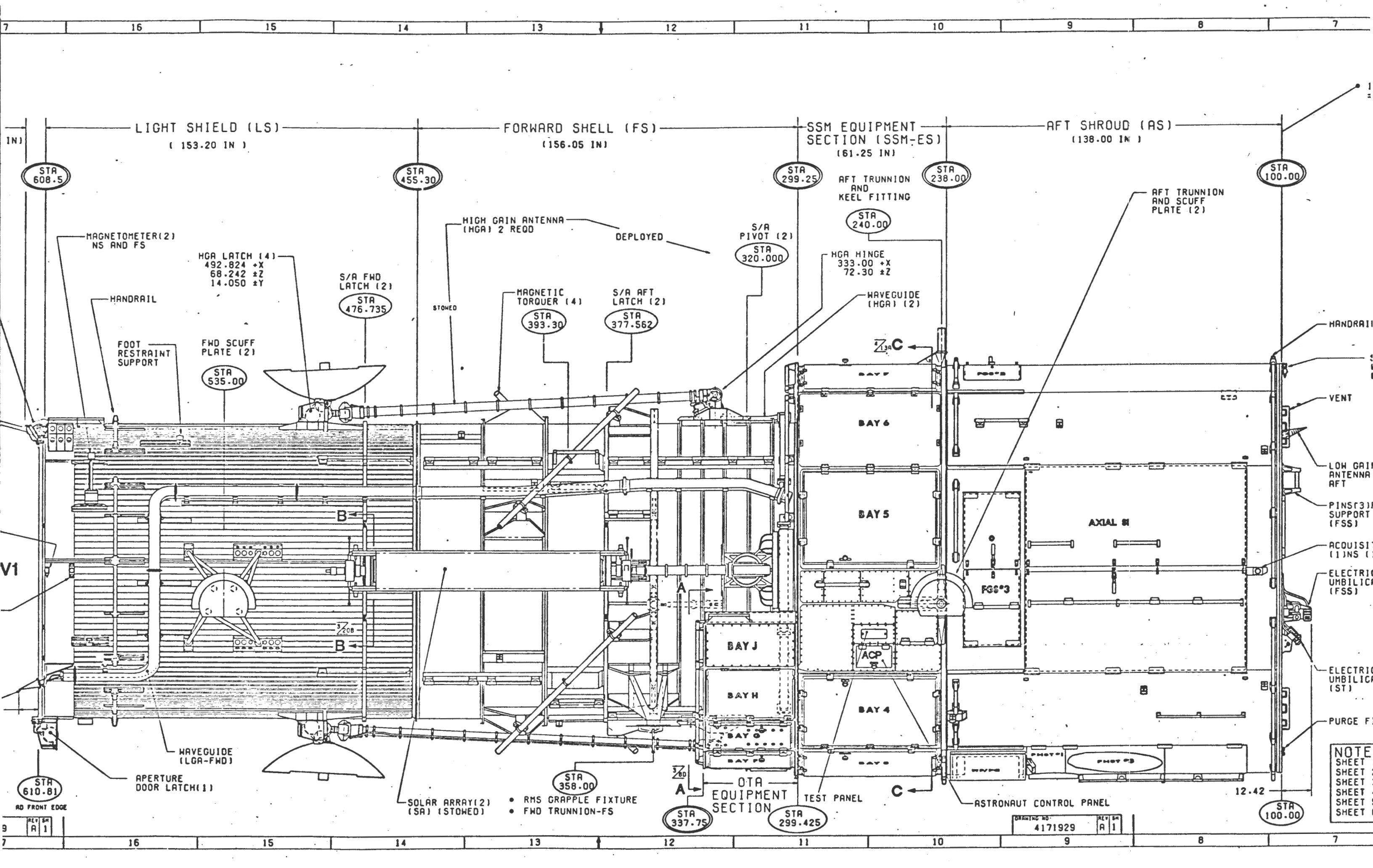

NOTE
 SHEET
 SHEET
 SHEET
 SHEET
 SHEET

DRAWING NO. 4171929
 REV. SH. A 1

REV. SH. A 1

10 9 8 7 6 5 4 3 2 1

| REVISIONS | | | |
|-----------|-----------|--------------|----------|
| ZONE | REV | DESCRIPTION | DATE |
| A | NO CHANGE | NOT RELEASED | 11 11 85 |
| | | | SCHMIDT |

LMSC/D974197B
31 May 1985

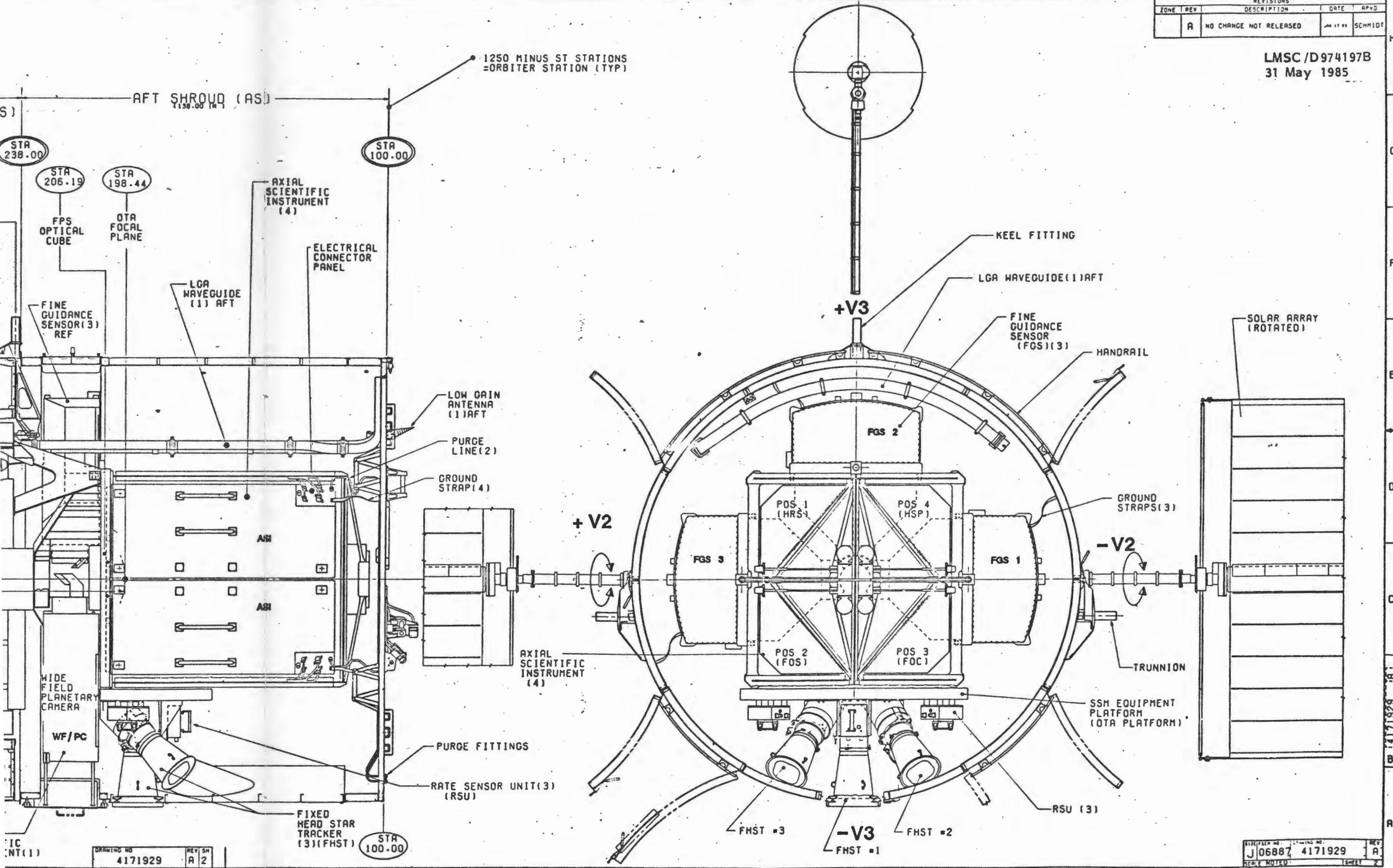

DRAWING NO. 4171929
REV. SH. A 2

SIZE/SCALE NO. 4171929
SCALE NOTED SHEET 2

10 9 8 7 6 5 4 3 2 1

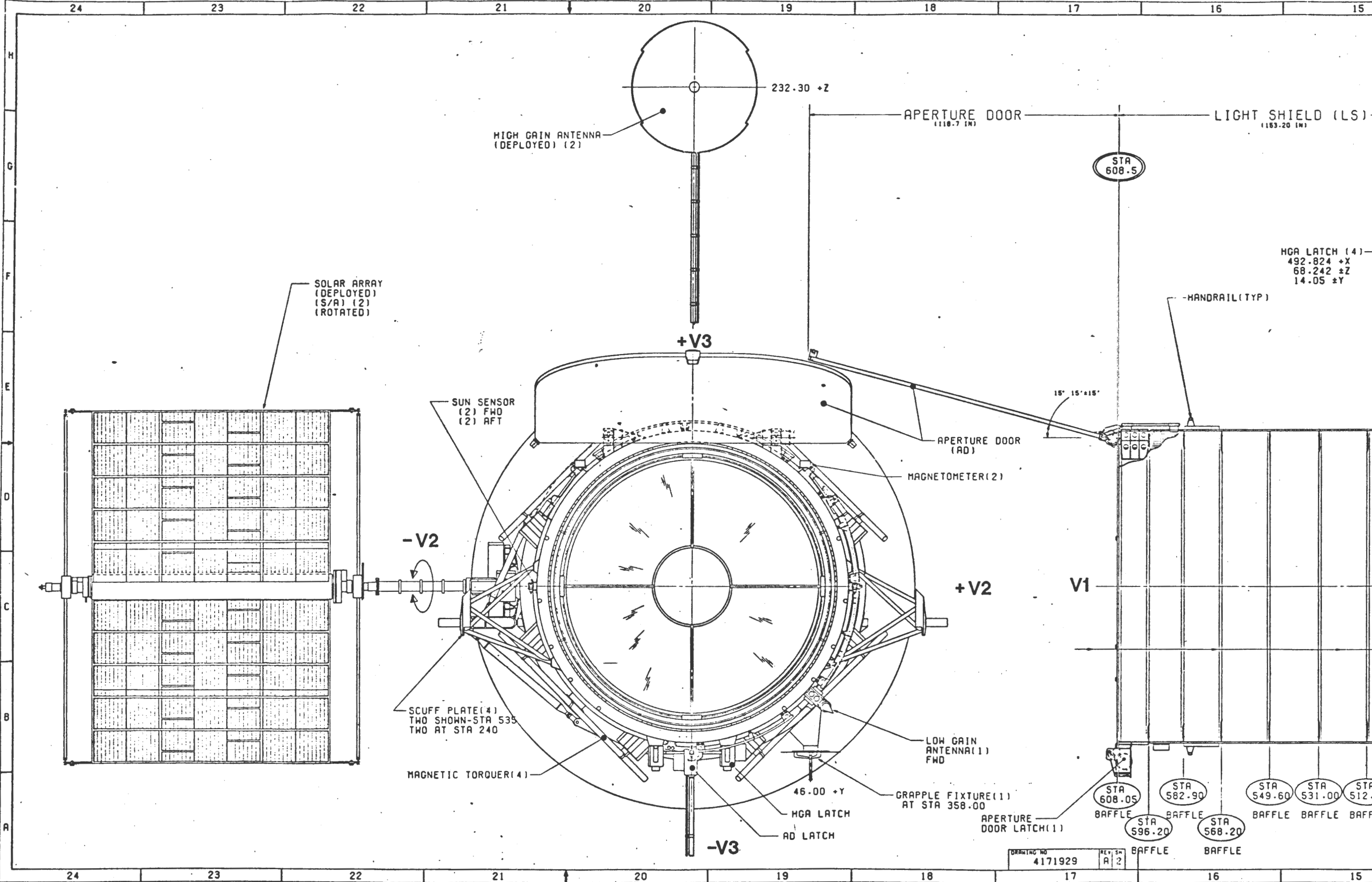

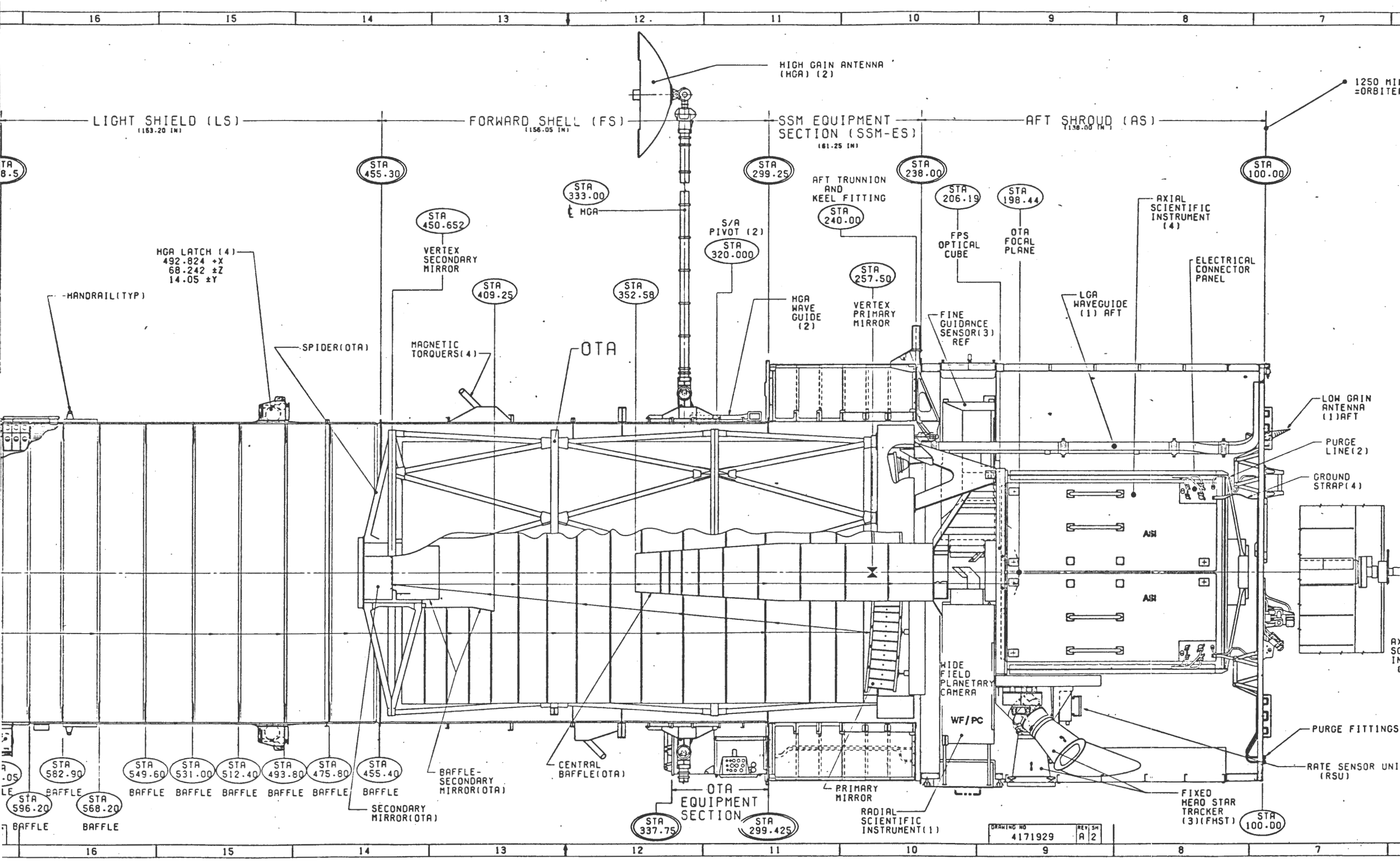

LIGHT SHIELD (LS)
1153.20 IN

FORWARD SHELL (FS)
1156.05 IN

SSM EQUIPMENT SECTION (SSM-ES)
161.25 IN

AFT SHROUD (AS)
1136.00 IN

1250 MI
= ORBITAL

STA 8.5

STA 455.30

STA 299.25

STA 238.00

STA 100.00

HGA LATCH (4)
492.824 ±X
68.242 ±Z
14.05 ±Y

HANDRAIL (TYP)

SPIDER (OTA)

STA 450.652
VERTEX SECONDARY MIRROR

MAGNETIC TORQUERS (4)

STA 409.25

STA 352.58

STA 333.00
HGA

OTA

S/A PIVOT (2)
STA 320.000

HGA WAVEGUIDE (2)

AFT TRUNNION AND KEEL FITTING

STA 240.00

STA 257.50
VERTEX PRIMARY MIRROR

STA 206.19
FPS OPTICAL CUBE

STA 198.44
OTA FOCAL PLANE

FINE GUIDANCE SENSOR (3) REF

LGA WAVEGUIDE (1) AFT

AXIAL SCIENTIFIC INSTRUMENT (4)

ELECTRICAL CONNECTOR PANEL

LOW GAIN ANTENNA (1) AFT

PURGE LINE (2)

GROUND STRAP (4)

AIR

AIR

WIDE FIELD PLANETARY CAMERA

WF/PC

PURGE FITTINGS

RATE SENSOR UNIT (RSU)

FIXED HEAD STAR TRACKER (3) (FHST)

STA 100.00

STA 596.20

STA 582.90

BAFFLE

STA 549.60

STA 531.00

STA 512.40

STA 493.80

STA 475.80

STA 455.40

BAFFLE-SECONDARY MIRROR (OTA)

SECONDARY MIRROR (OTA)

CENTRAL BAFFLE (OTA)

OTA EQUIPMENT SECTION

STA 337.75

STA 299.425

PRIMARY MIRROR

RADIAL SCIENTIFIC INSTRUMENT (1)

DRAWING NO 4171929

REV SA A 2

16

15

14

13

12

11

10

9

8

7

10 9 8 7 6 5 4 3 2 1

| REVISIONS | | | | |
|-----------|-----|------------------------|----------|---------|
| ZONE | REV | DESCRIPTION | DATE | APP'D |
| A | | NO CHANGE NOT RELEASED | 20 11 85 | SCHMIDT |

LMSC /D974197B
31 May 1985

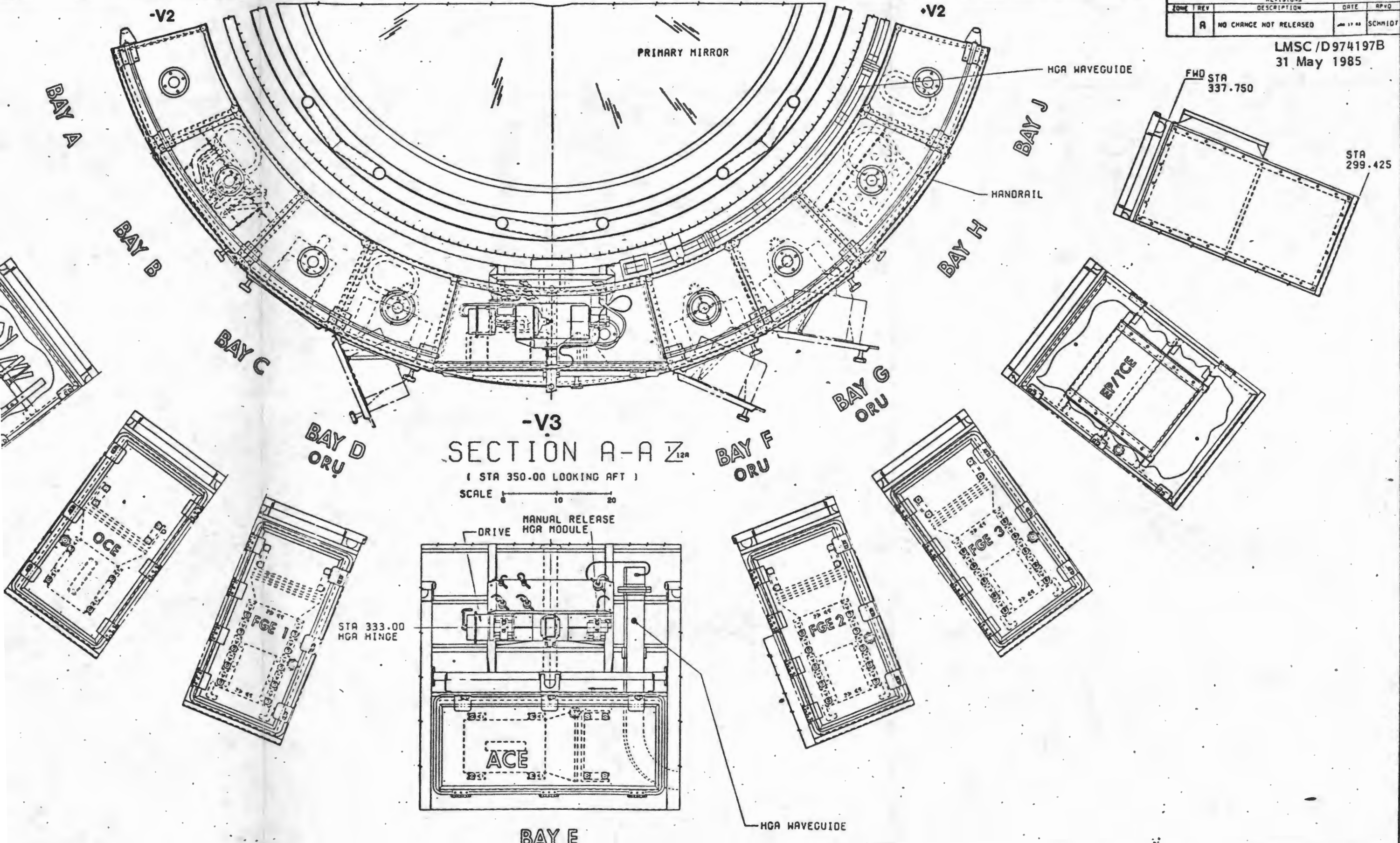

-V3
SECTION A-A \nearrow
(STA 350.00 LOOKING AFT)

SCALE 0 10 20

MANUAL RELEASE
DRIVE HGA MODULE

STA 333.00
HGA HINGE

HGA WAVEGUIDE

B 4171929-3A

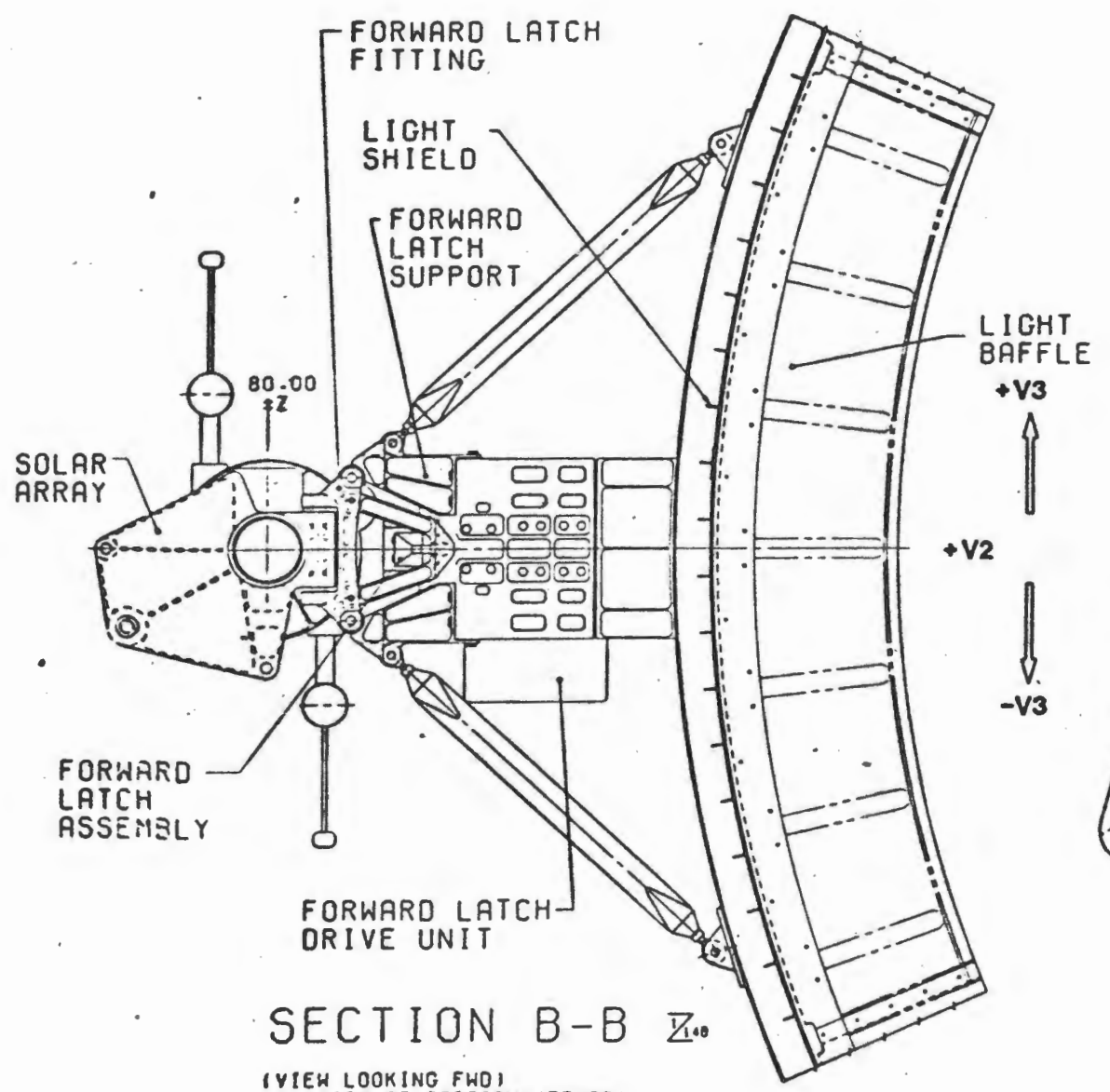

SECTION B-B

(VIEW LOOKING FWD)
(SECTION AT STATION 475.00)
+V2 SHOWN
-V2 ROTATE 180 DEG

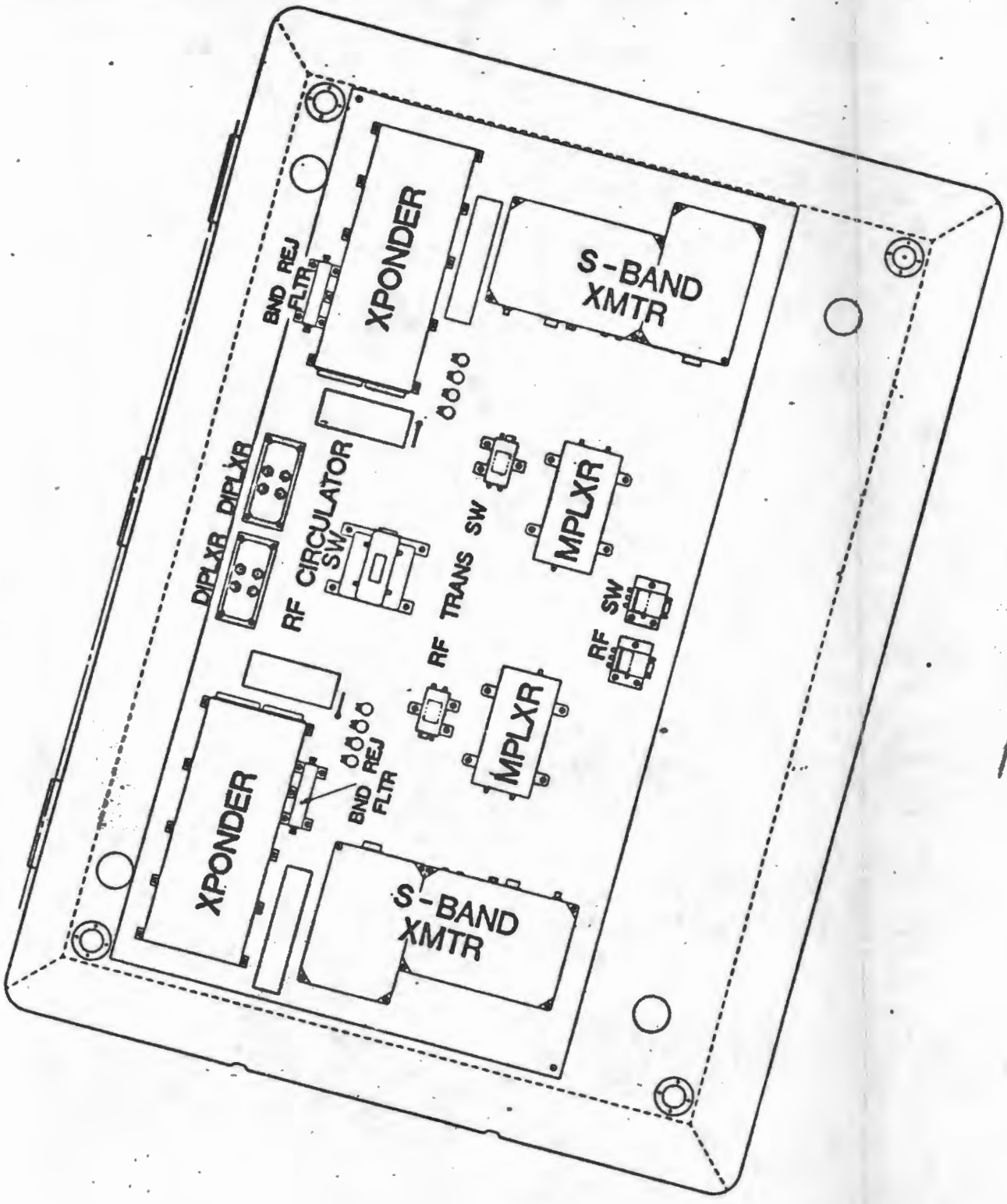
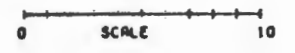

SECTION P-P

VIEW OF BAY 5 DOOR

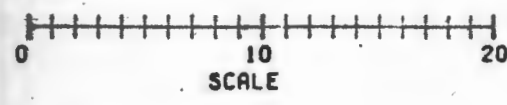

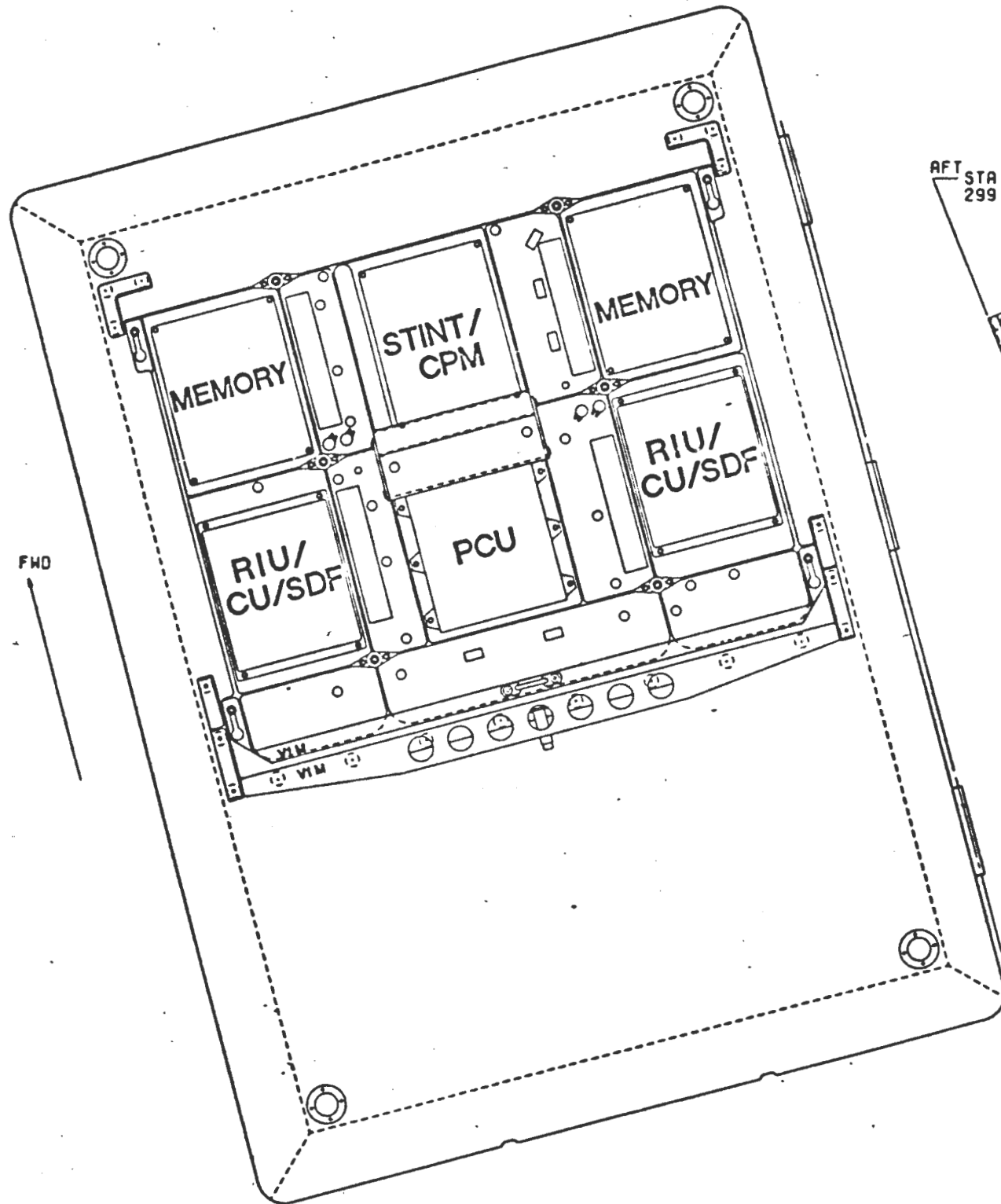

BAY A

BAY B

BAY C

BAY D ORU

-V2

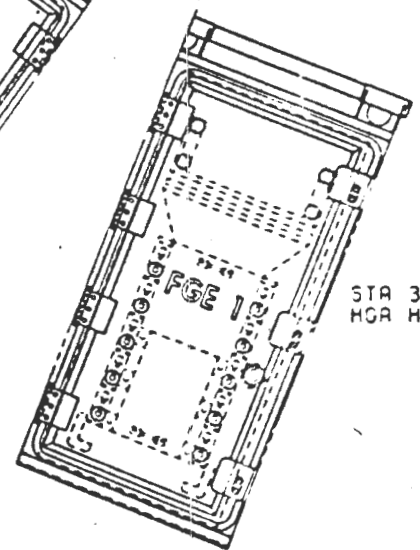
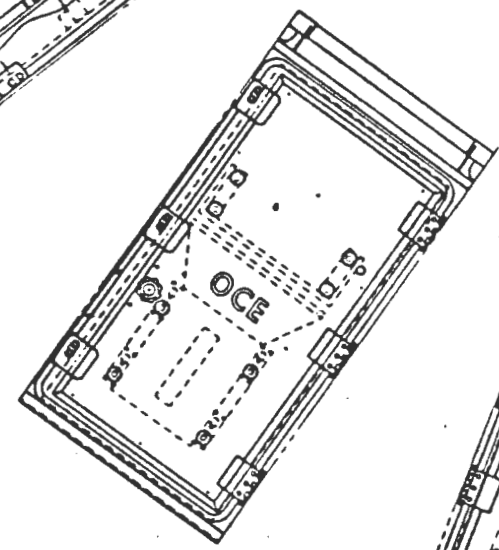
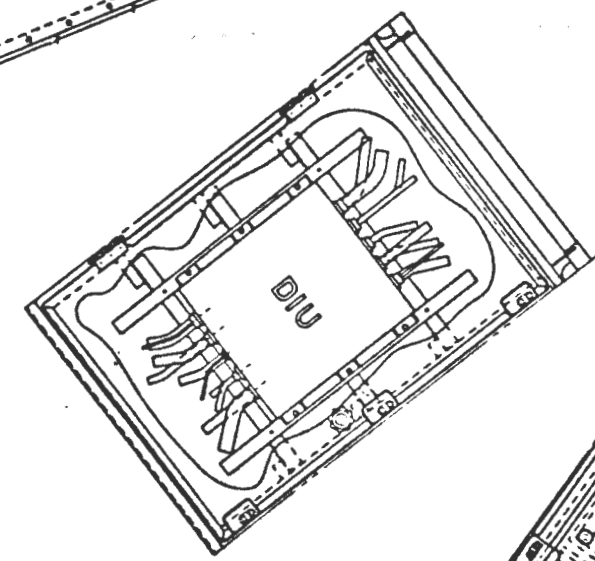

STA 333.00
MGR HINGE

SEC
I STA
SCALE

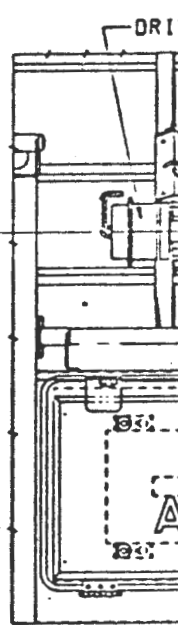

SECTION R-R ∇
VIEW OF BAY 10 DOOR

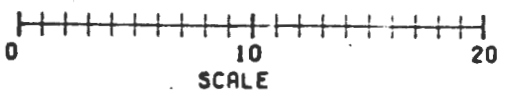

| | |
|-----------------------|---------------|
| DRAWING NO 4171929 | REV SH A 3 |
|-----------------------|---------------|

| REVISIONS | | | | |
|-----------|-----|------------------------|-------|---------|
| ZONE | REV | DESCRIPTION | DATE | APVD |
| | A | NO CHANGE NOT RELEASED | 27 85 | SCHMIDT |

LMSC/D974197B
31 May 1985

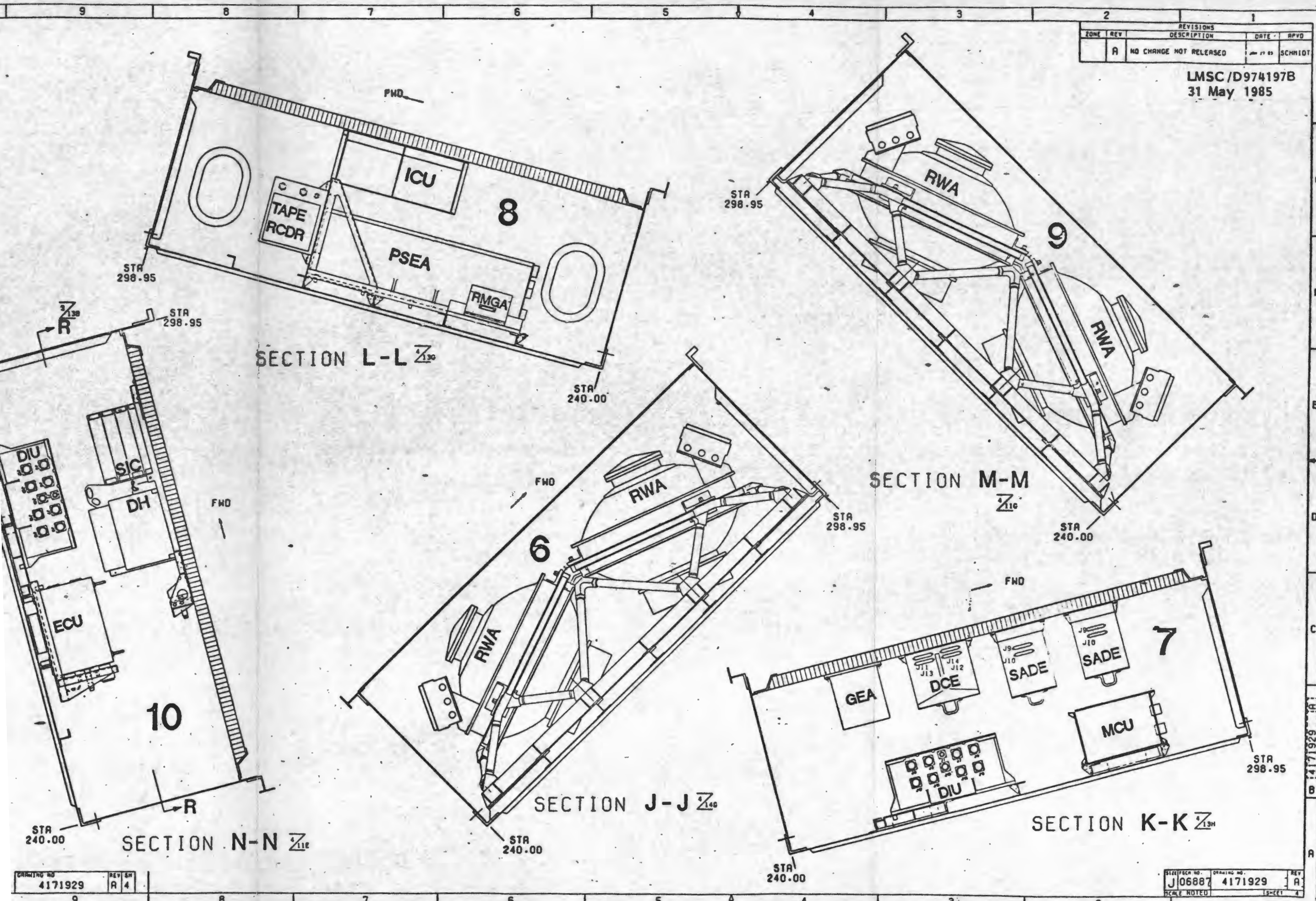

| | |
|-------------|-----|
| DRAWING NO. | REV |
| 4171929 | A 4 |

| | | |
|-------------|-------------|-----|
| SHEET NO. | DRAWING NO. | REV |
| J06887 | 4171929 | A |
| SCALE NOTED | SHEET | 4 |

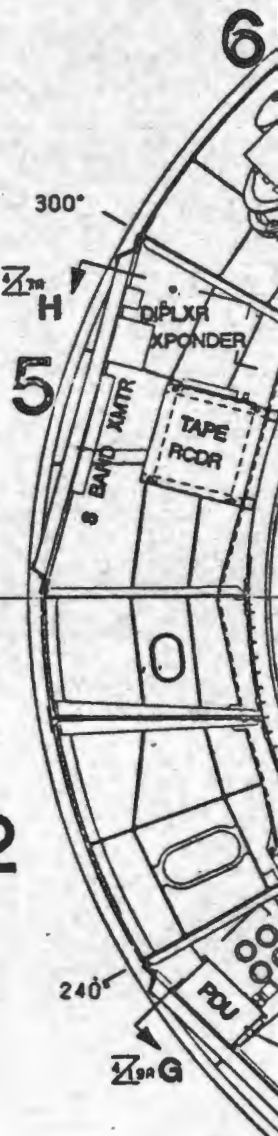
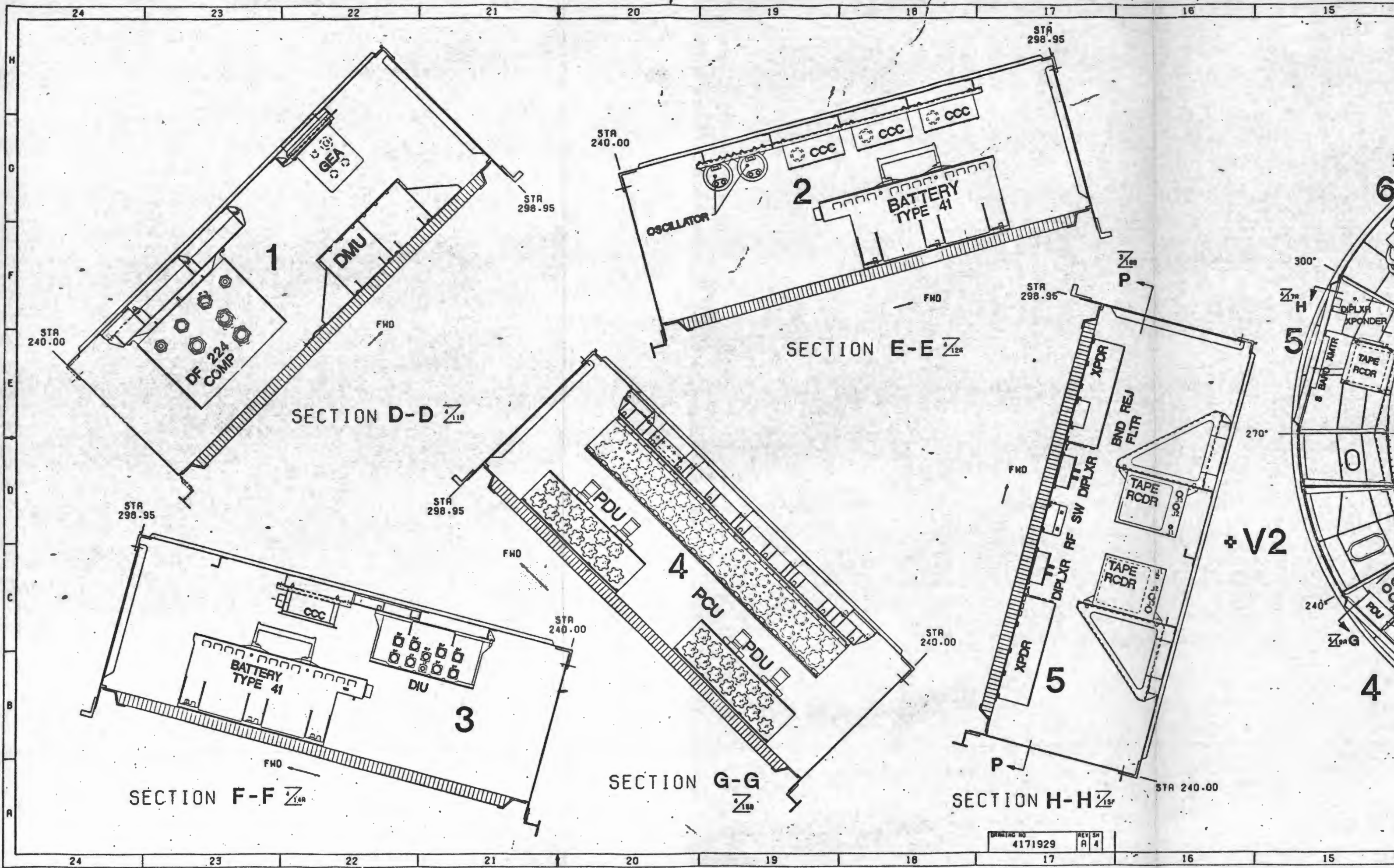

| | |
|-------------|---------|
| PRINTING NO | REV. SH |
| 4171929 | A 4 |

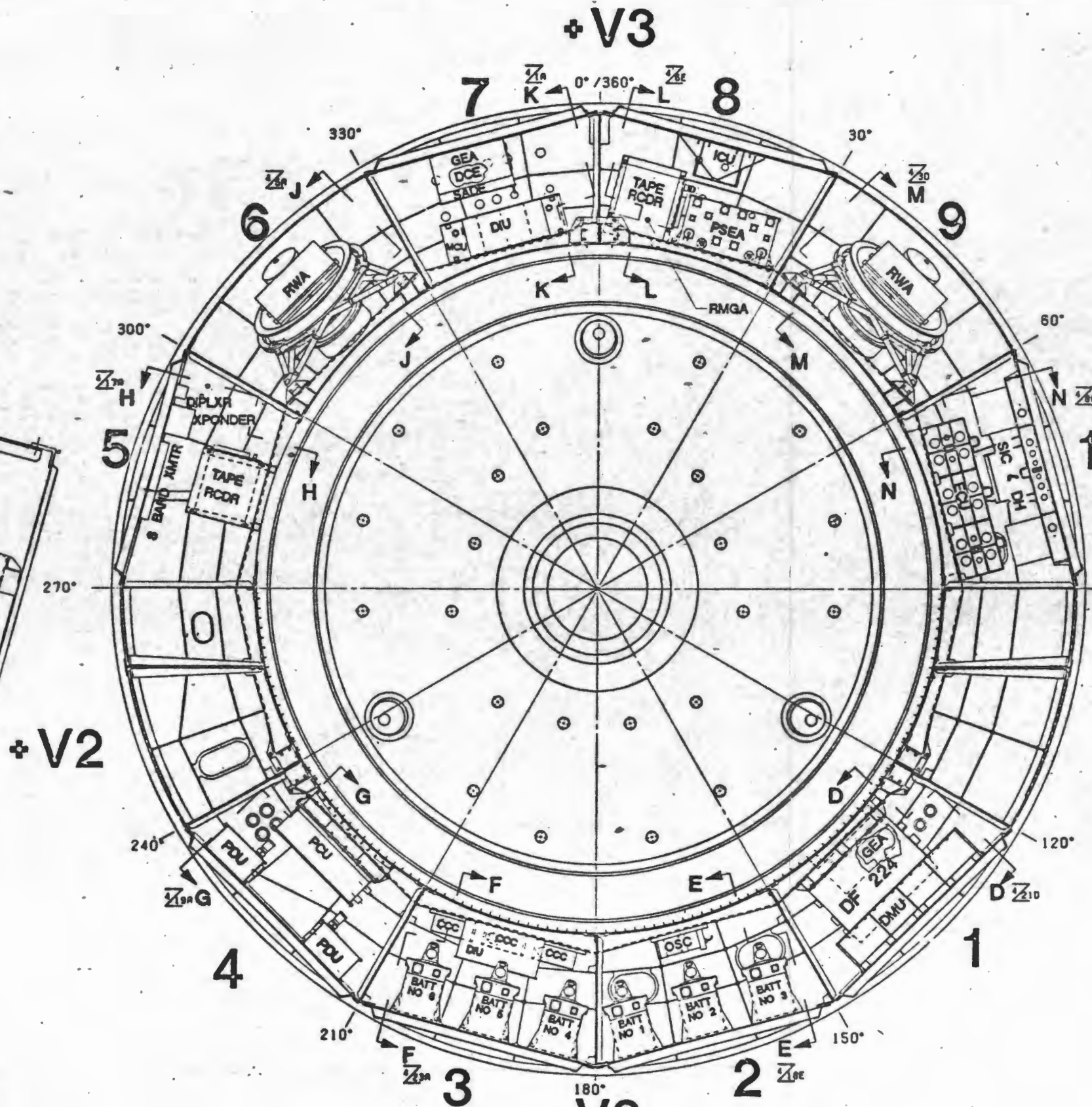

+V3
-V3
SECTION C-C
 LOOKING FWD

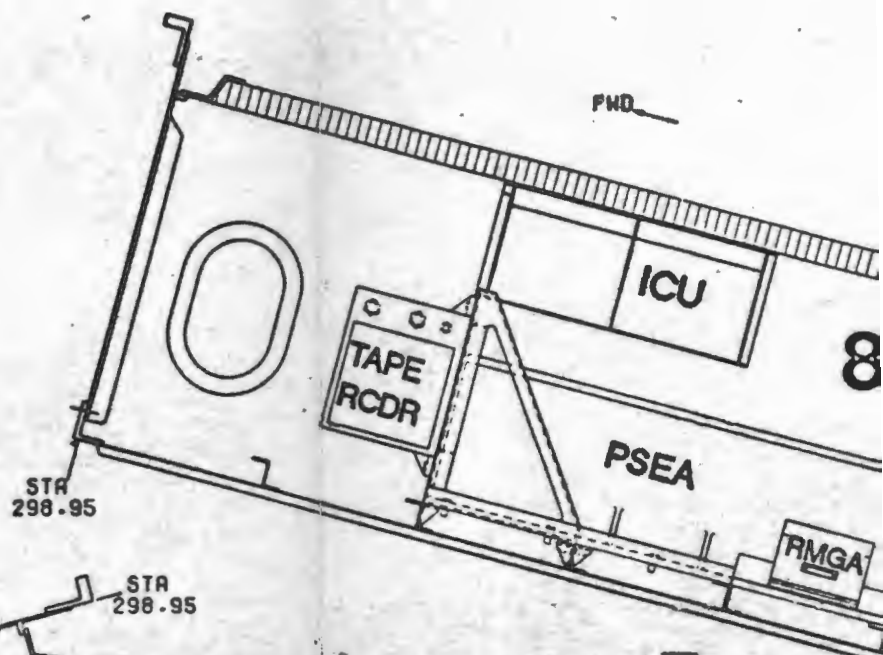

SECTION L-L

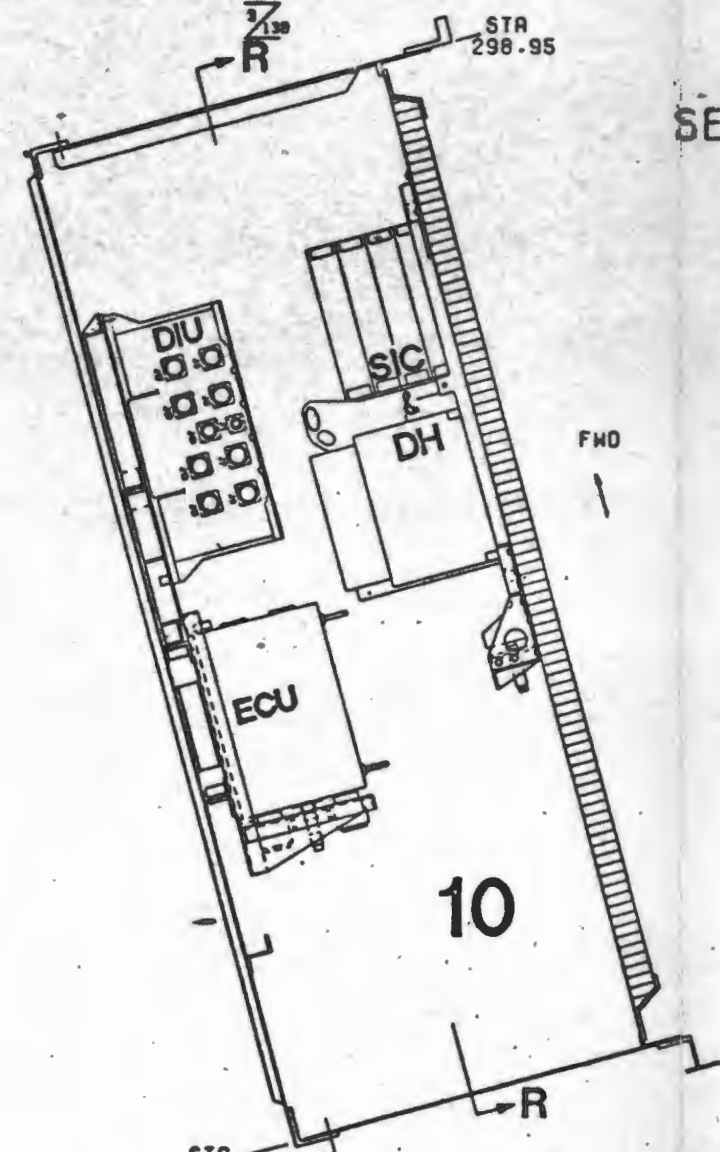

SECTION N-N

| | |
|------------|-----|
| DRAWING NO | REV |
| 4171929 | R 4 |

| REVISIONS | | | | |
|-----------|-----|------------------------|-----------|---------|
| ZONE | REV | DESCRIPTION | DATE | APVD |
| A | | NO CHANGE NOT RELEASED | 000 01 00 | SCHMIDT |

LMSC/D974197B
31 May 1985

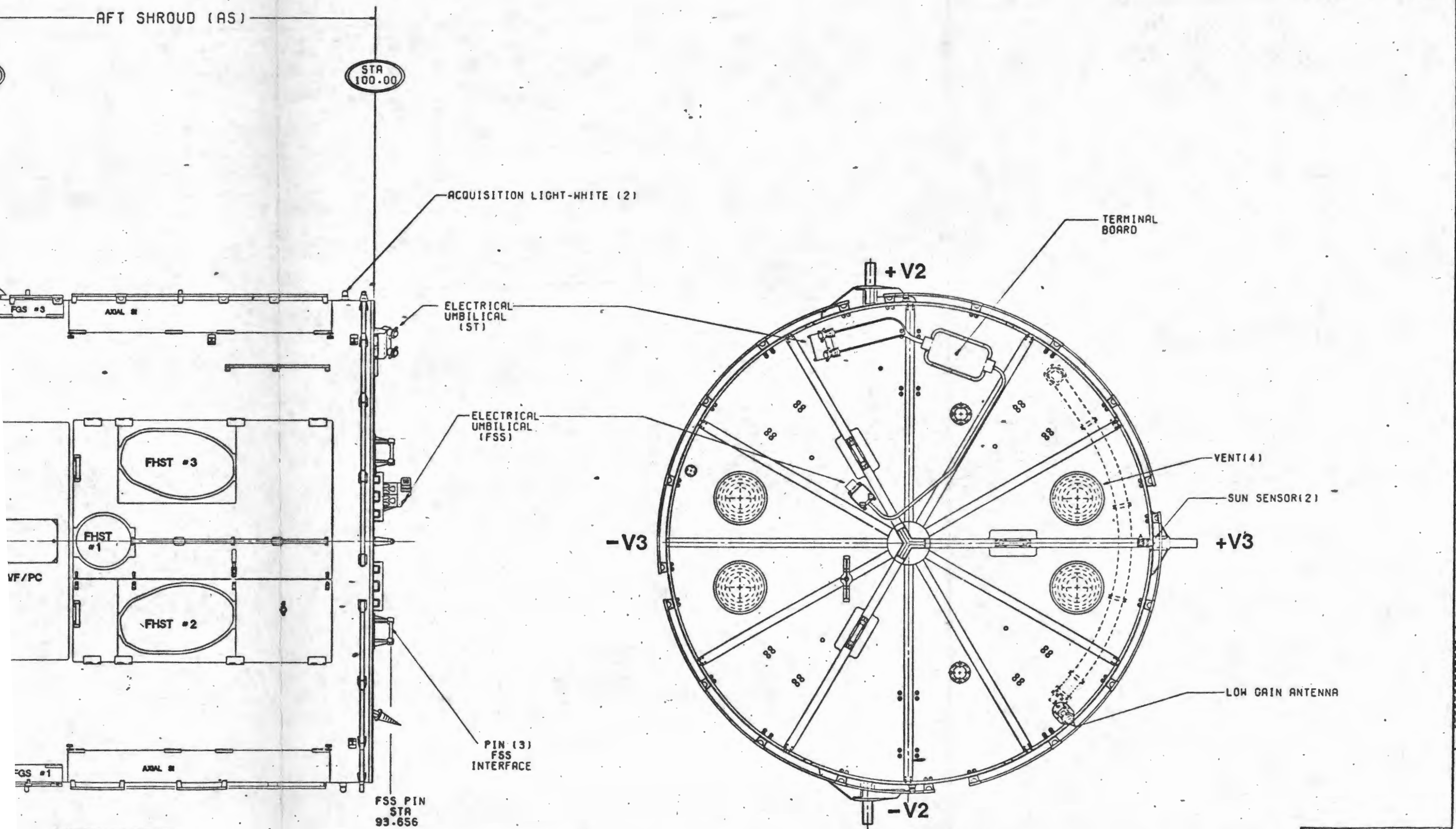

DRAWING NO
4171929

REV 5
A 5

ITEM/PCB NO. DRAWING NO.
J06887 4171929

SCALE NOTED 15-117 5

24

23

22

21

20

19

18

17

16

15

H
G
F
E
D
C
B
A

LIGHT SHIELD (LS)

STA 608.5

HIGH GAIN ANTENNA

FWD SCUFF PLATE (2)

STA 535.00

FOOT RESTRAINT SUPPORT

WAVEGUIDE LGA

SOLAR ARRAY ASSY

SCUFF PLATE (2)

MAGNETIC TORQUER (4)

270°
+V2

ACQUISITION LIGHT- RED

SUN SENSOR (2)

LOW GAIN ANTENNA

GRAPPLE FIXTURE

HGA LATCH-SLAVE

HIGH GAIN ANTENNA (HGA)

360°
+V3
0°

APERTURE DOOR LATCH

-V3
180°

HGA LATCH-DRIVER

APERTURE DOOR

ACQUISITION LIGHT-GREEN

-V2 90°

DRAWING NO 4171929 REV SH A 5

24

23

22

21

20

19

18

17

16

15

LIGHT SHIELD (LS) FORWARD SHELL (FS) SSM EQUIPMENT SECTION (SSM-ES) AFT SHROUD (AS)

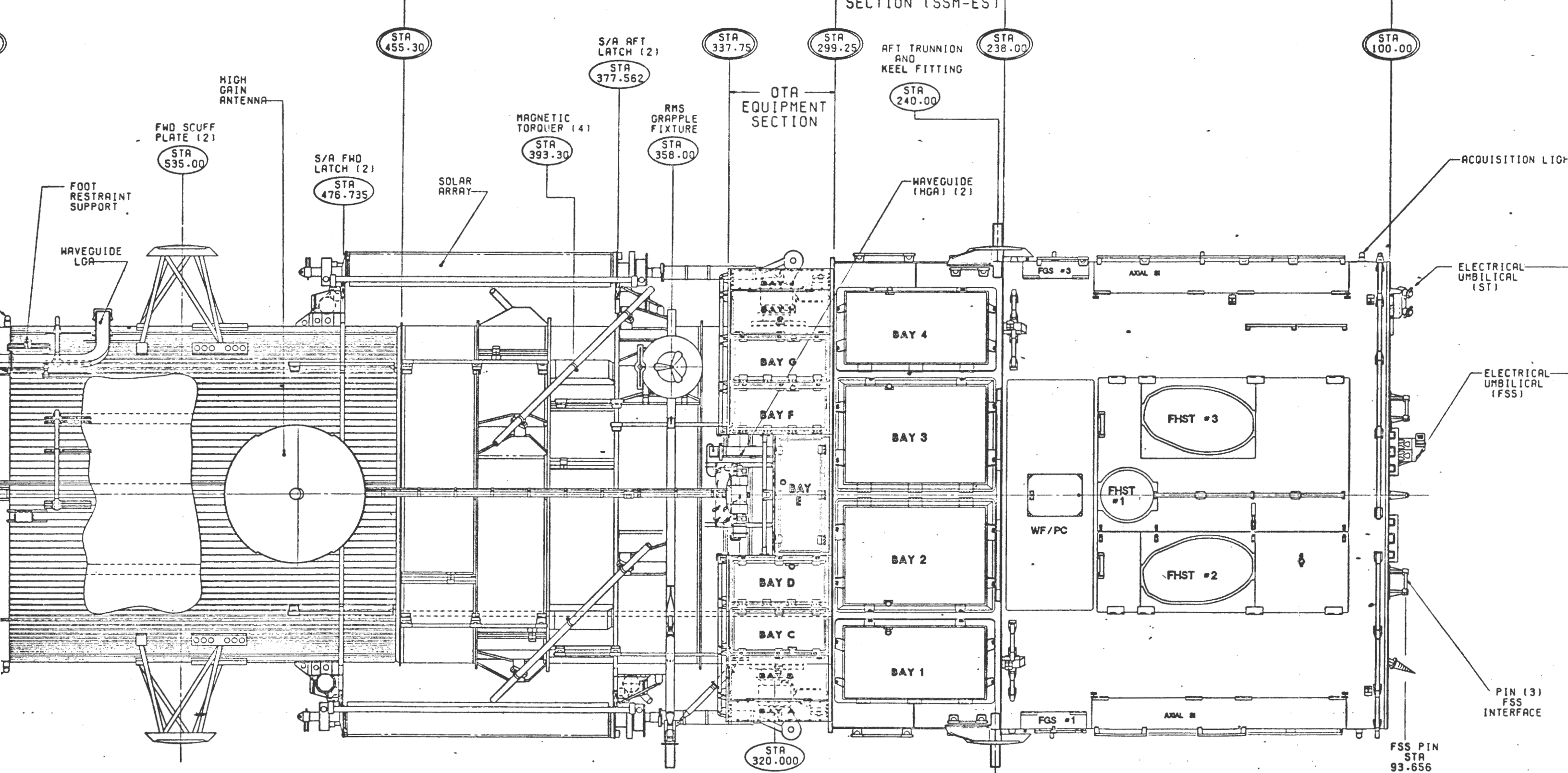

STA 455.30

S/A AFT LATCH (2)
STA 377.562

STA 337.75

STA 299.25

STA 238.00

STA 100.00

FWD SCUFF PLATE (2)
STA 535.00

S/A FWD LATCH (2)
STA 476.735

MAGNETIC TORQUER (4)
STA 393.30

RMS GRAPPLE FIXTURE
STA 358.00

AFT TRUNNION AND KEEL FITTING
STA 240.00

OTA EQUIPMENT SECTION

WAVEGUIDE (HGA) (2)

ACQUISITION LIGHT

ELECTRICAL UMBILICAL (ST)

ELECTRICAL UMBILICAL (FSS)

PIN (3) FSS INTERFACE

FSS PIN STA 93.656

STA 320.000
S/A PIVOT (2)

| | | |
|------------|-----|----|
| DRAWING NO | REV | SH |
| 4171929 | A | S |

| REVISIONS | | | | |
|-----------|-----|------------------------|-------|---------|
| ZONE | LTR | DESCRIPTION | DATE | APVD |
| A | | NO CHANGE NOT RELEASED | 17 85 | SCHMIDT |

LMSC/D974197B
31 May 1985

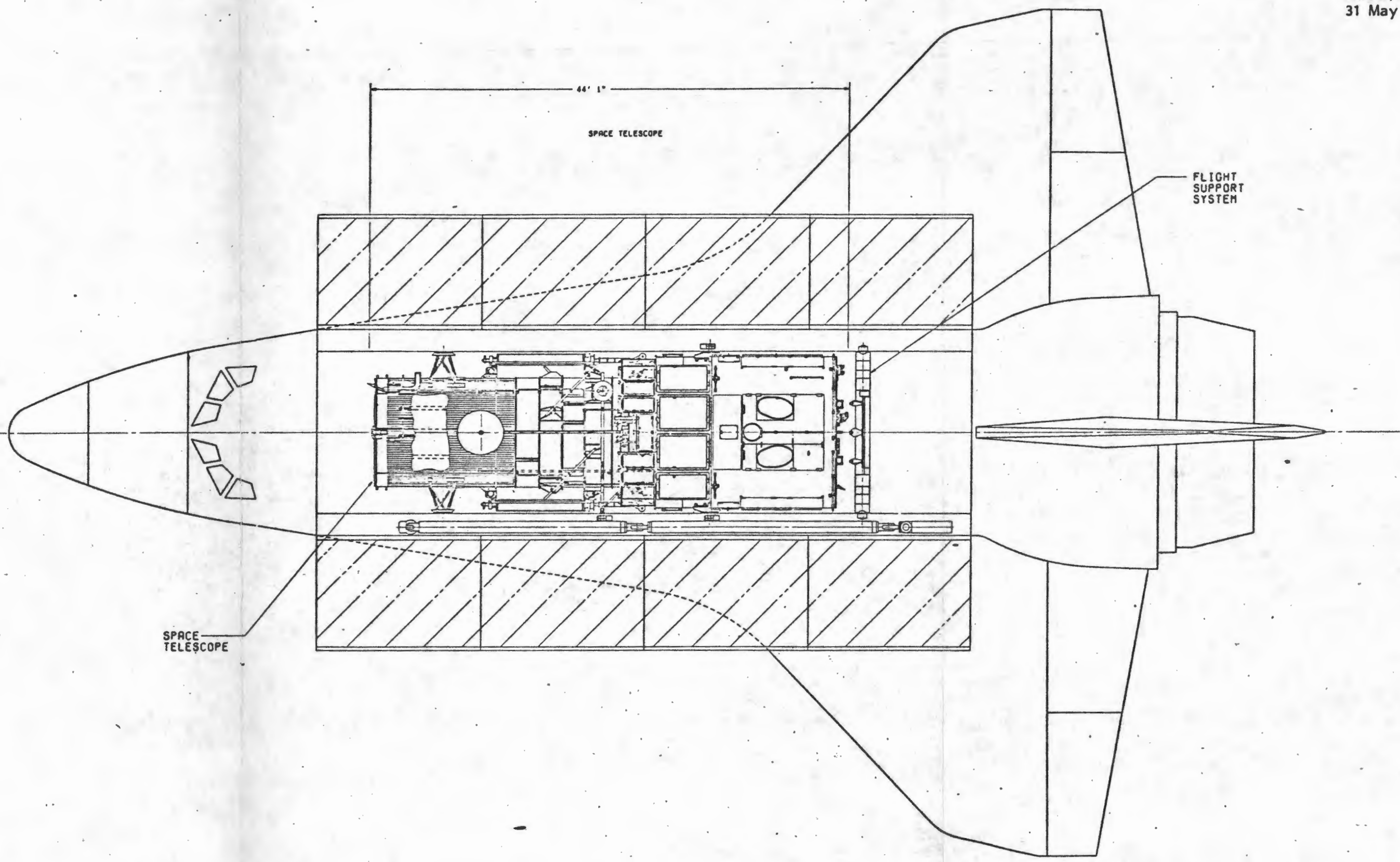

SPACE TELESCOPE

SPACE TELESCOPE

FLIGHT SUPPORT SYSTEM

DRAWING NO
4171929

REV. SH
A 6

SIZE CODE IDENT. DRAWING NO. REV
J06887 4171929 A
SCALE .03 SHEET 6

24

23

22

21

20

19

18

17

16

15

H
G
F
E
D
C
B
A

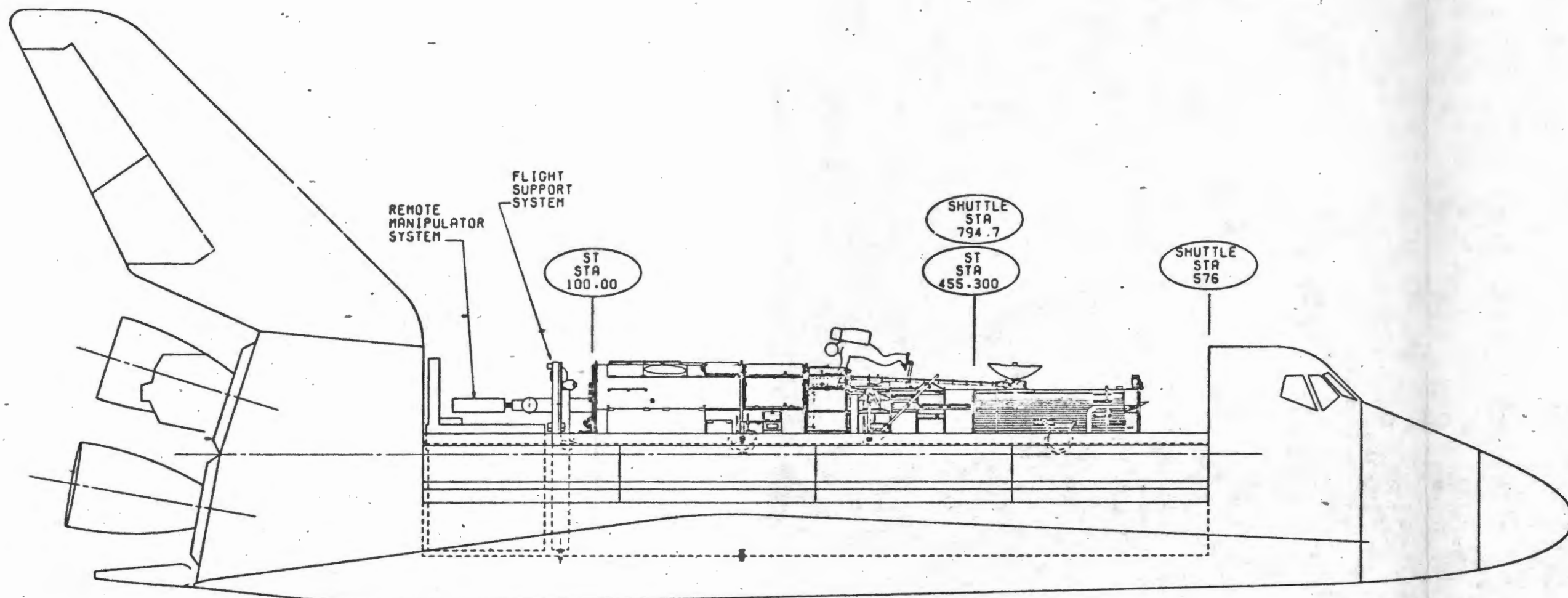

| | | |
|------------|-----|----|
| DRAWING NO | REV | SN |
| 4171929 | A | 6 |

24

23

22

21

20

19

18

17

16

15

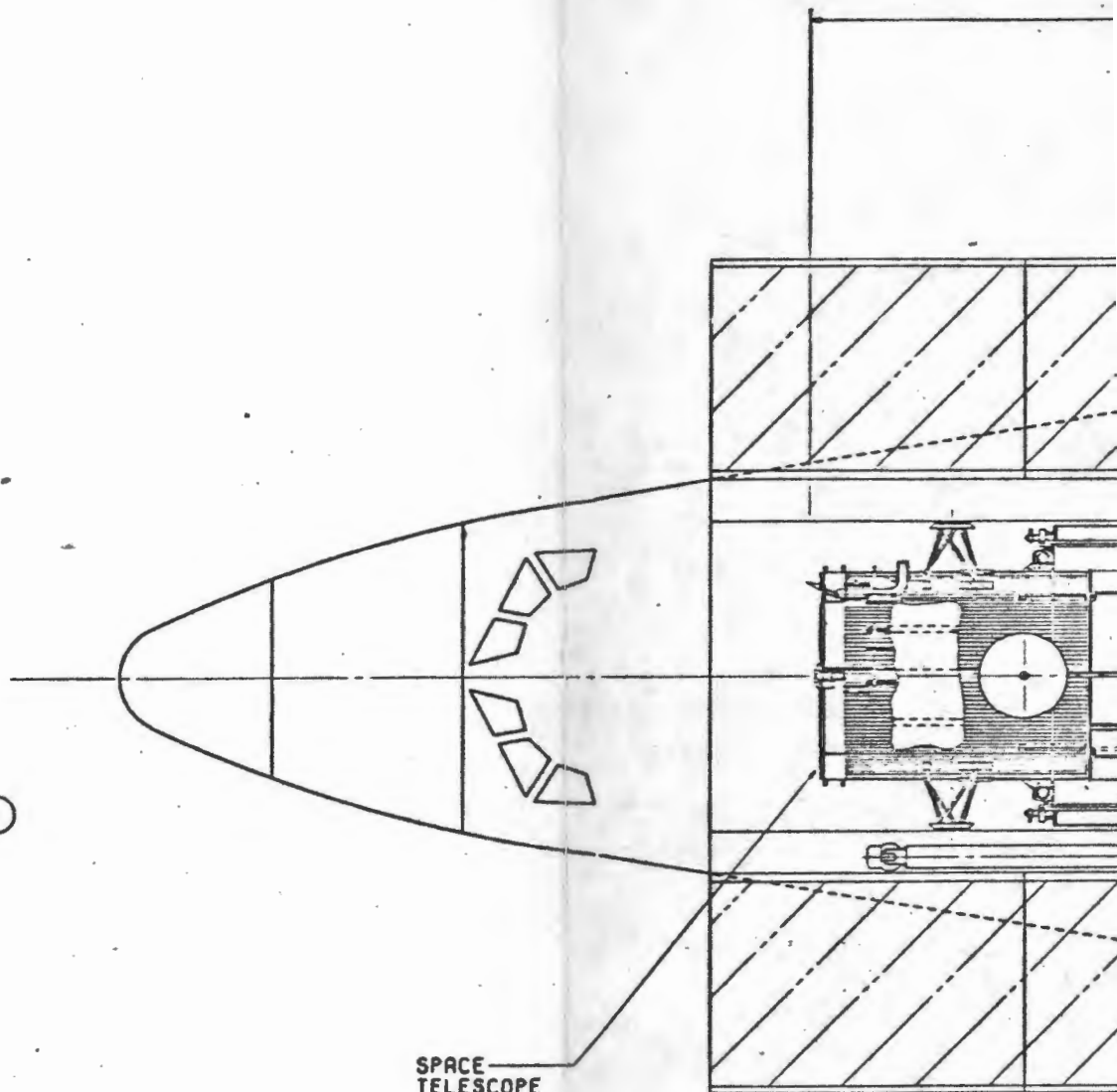
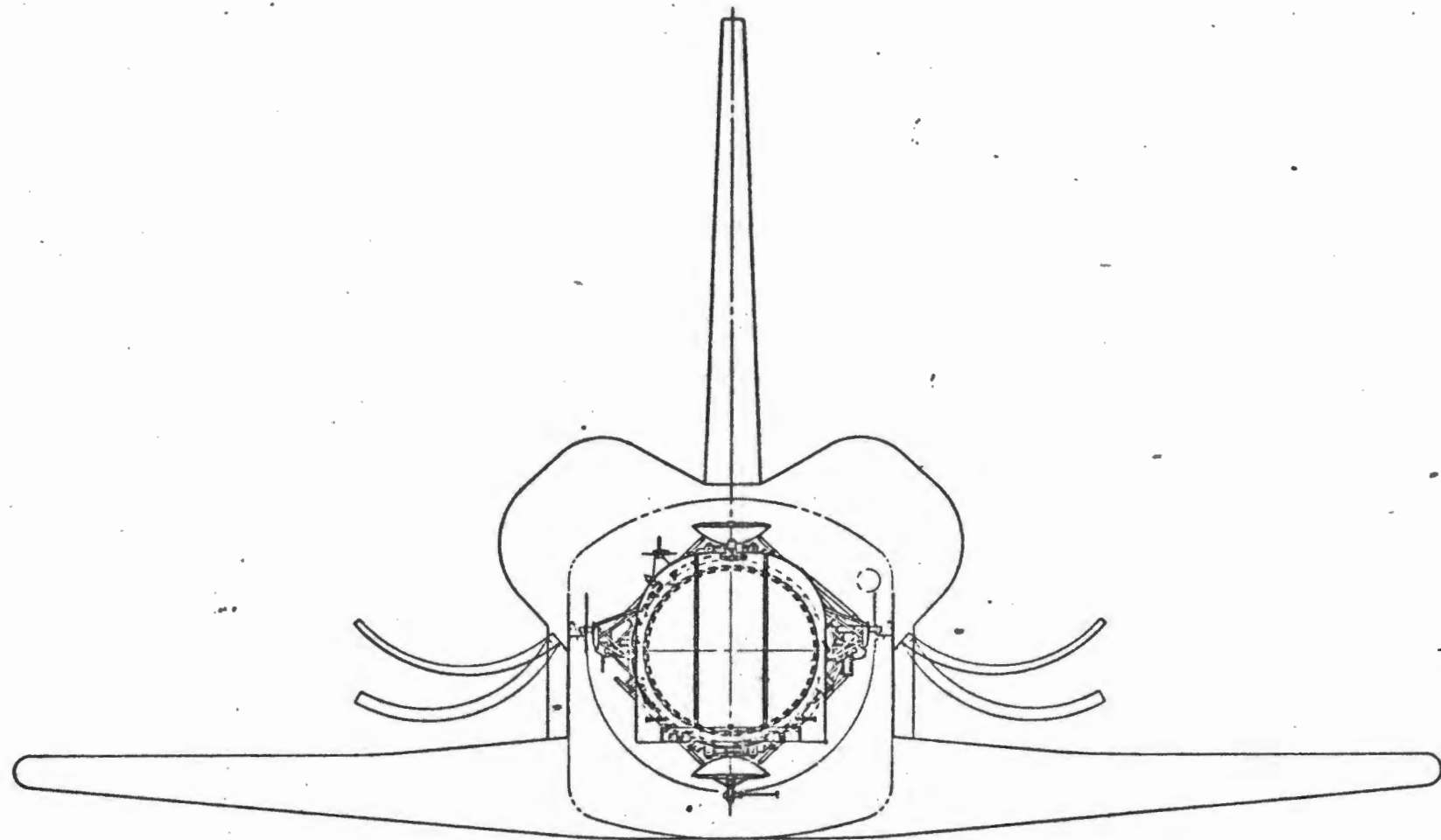

SPACE
TELESCOPE