

Cold Helium Gas Pressurization For Spacecraft Cryogenic Propulsion Systems

Robert L. Morehead¹, Matthew J. Atwell², Eric A. Hurlbert³, and J.C. Melcher⁴
NASA Johnson Space Center, Houston, TX, 77058, United States

Abstract

To reduce the dry mass of a spacecraft pressurization system, helium pressurant may be stored at low temperature and high pressure to increase mass in a given tank volume. Warming this gas through an engine heat exchanger prior to tank pressurization both increases the system efficiency and simplifies the designs of intermediate hardware such as regulators, valves, etc. since the gas is no longer cryogenic. If this type of cold helium pressurization system is used in conjunction with a cryogenic propellant, though, a loss in overall system efficiency can be expected due to heat transfer from the warm ullage gas to the cryogenic propellant which results in a specific volume loss for the pressurant, interpreted as the Collapse Factor. Future spacecraft with cryogenic propellants will likely have a cold helium system, with increasing collapse factor effects as vehicle sizes decrease. To determine the collapse factor effects and overall implementation strategies for a representative design point, a cold helium system was hotfire tested on the Integrated Cryogenic Propulsion Test Article (ICPTA) in a thermal vacuum environment at the NASA Glenn Research Center Plum Brook Station.

The ICPTA vehicle is a small lander-sized spacecraft prototype built at NASA Johnson Space Center utilizing cryogenic liquid oxygen/liquid methane propellants and cryogenic helium gas as a pressurant to operate one 2,800lbf 5:1 throttling main engine, two 28lbf Reaction Control Engines (RCE), and two 7lbf RCEs (Figure 1). This vehicle was hotfire tested at a variety of environmental conditions at NASA Plum Brook, ranging from ambient temperature/simulated high altitude, deep thermal/high altitude, and deep thermal/high vacuum conditions. A detailed summary of the vehicle design and testing campaign may be found in *Integrated Cryogenic Propulsion Test Article Thermal Vacuum Hotfire Testing*, AIAA JPC 2017.

The cold helium experiment of the ICPTA test campaign is a continuation of an experiment first performed in 2015 at sea-level conditions¹. Since that time, the ICPTA was rebuilt for the thermal vacuum environment and the cold helium system was upgraded with improved instrumentation/controls and for a larger main engine nozzle. The major difference between the first and second rounds of this experiment are the operating conditions of the vehicle itself and the propellant tank fill levels. During the first iteration of this cold helium experiment (conducted at sea level ambient conditions), the propellant tanks were operated at the ¼ fill level and little dynamic pressurant/propellant interaction was observed. During this second iteration of the experiment at NASA Plum Brook, the propellant



Figure 1: Integrated Cryogenic Propulsion Test Article (ICPTA) installed in the NASA Plum Brook In-Space

¹ Propulsion System Engineer, Propulsion Systems Branch EP4, AIAA Member

² Propulsion System Engineer, Propulsion Systems Branch EP4, AIAA Member

³ Propulsion System Engineer, Propulsion Systems Branch EP4, AIAA Member

⁴ Propulsion System Engineer, Propulsion Systems Branch EP4, AIAA Senior Member

tanks were filled up to 98% full, greatly increasing the pressurant/propellant interaction and impacting the instantaneous and cumulative Collapse Factors accordingly.

The deep thermal conditions experienced during this test campaign further impacted the Collapse Factor due to the high thermal mass of the helium system hardware (at cryogenic conditions) and thereby the higher thermal sink for the warmed pressurant. The individual and combined effects observed during this test campaign were compared to the sea level results from the first iteration to express the Collapse Factor in terms of varying environmental and operational conditions.

The cold helium system on the ICPTA consisted of (in order of flow) one 19" spherical COPV, fill/relief valves, a helium heat exchanger mounted on the nozzle of the main engine, control valves/regulators/reliefs/check valves, flowmeters, and tank diffuser (Figures 2 and 3). The nominal operating conditions of the COPV were 3600 psi and -250F, equating to ~9lb of helium, which allowed main engine burn times up to one minute duration. The cold helium system was not operated during RCE-only test firings. The COPV had an aluminum liner, contrasted with an Inconel lined version used in the first experiment iteration, and has a MAWP of 4,500 psi. Helium was loaded into the COPV from the facility at room temperature and 3600 psi, and was chilled to cryo conditions in the tank using LN2 which passed through additively manufactured aluminum heat exchangers mounted on the upper and lower tank bosses to chill the tank liner and thereby the helium gas. The helium heat exchanger on the main engine was a two-pass additively manufactured Inconel ring located at the AR=10 location on the main engine nozzle. Two versions of the HEX were tested, one flange-mounted at the AR=10 location of a two-part ablatively lined thrust chamber assembly, and the other cast into the AR=10 location of a single-part ablative thrust chamber assembly. Both units were hotfire tested with TBD results. Thermocouples on the upstream and downstream lips and inlet/outlet ports of each HEX provided real-time health of the HEX during hot firings.



Figure 2. ICPTA Helium Regulation and Control Panel

Another addition to this version of the experiment are pressurant inlet diffusers on the propellant tanks. These additively manufactured diffusers reduced axial pressurant/propellant impingement velocity by ~40% and eliminated cross flow. Hotfire tests were performed with and without diffusers to collect validation data for CFD models.

Instrumentation on the cold helium system consisted of dozens of surface and immersed thermocouples, pressure sensors, and flowmeters. Thermocouple rakes in the helium and propellant tanks provided information on thermal strata during all phases of loading, quiescent, and hotfire operations with active pressurization. Surface thermocouples on the plumbing, helium, and propellant tanks provided system environmental condition information and measured heat loss into that hardware. Helium flowmeters for each propellant are an upgrade from the previous experiment and provided quantification of pressurant flow into each propellant tank pair.

Model validation was a primary objective of this experiment. Integrated helium system models were built to simulate the multiple physical processes throughout the pressurization system and were validated against test data. Collapse Factor terms were then developed using empirical and model data as a resource to help guide the development of cold helium systems for future spacecraft with cryogenic propellants.

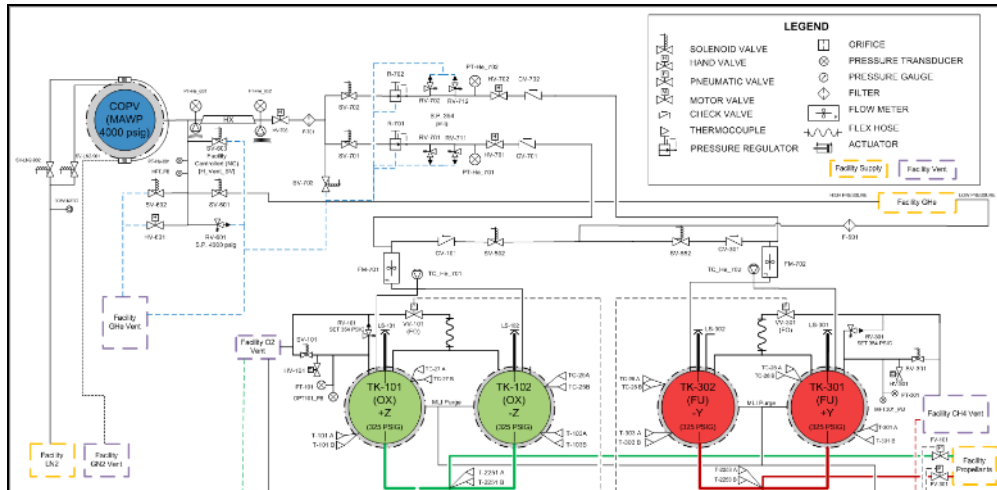

Figure 3: ICPTA Helium System Schematic

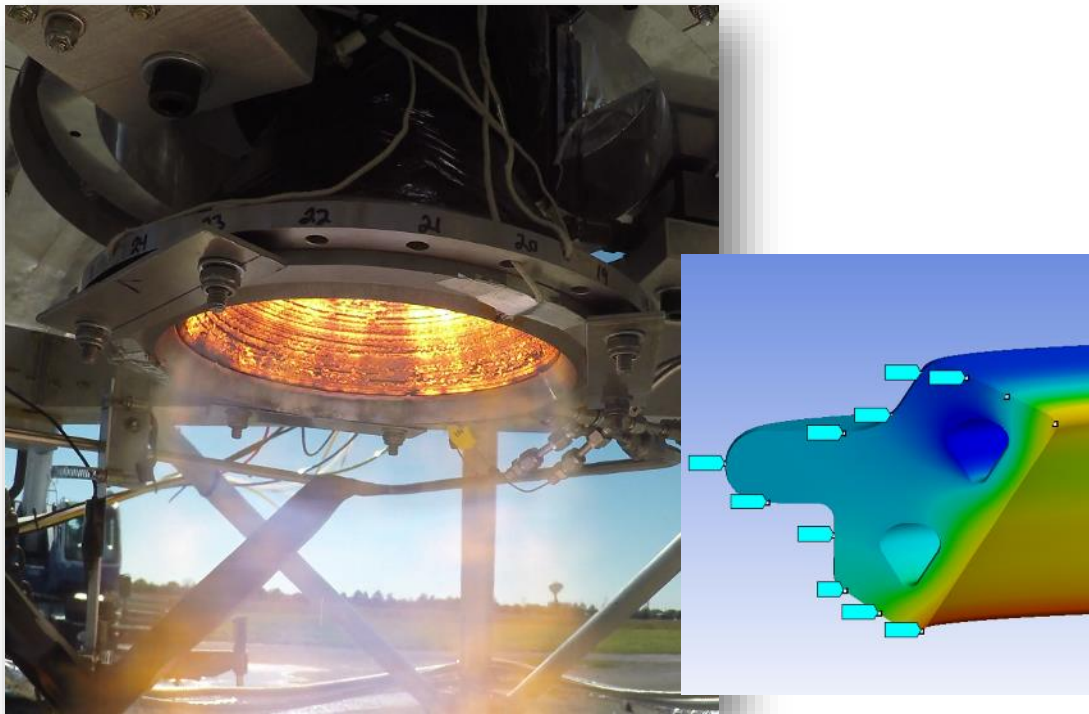

Figure 4: Engine Plume Impingement on HEX during hotfire checkout testing at NASA JSC (sea level) prior to thermal vacuum testing at NASA Plum Brook. Nozzle extension not installed during this hotfire test. Inset picture shows an ANSYS steady state thermal prediction of the HEX at max

¹ Morehead, R., Atwell, M., Melcher, J., Hurlbert, E., “Cold Helium Pressurization for Liquid Oxygen / Liquid Methane Propulsion Systems: Fully-Integrated Initial Hot-Fire Test Results” 52nd AIAA/ASME/SAE/ASEE Joint Propulsion Conference, 2016