

Experimenting Galileo on Board the International Space Station

Samuele Fantinato⁽¹⁾, Oscar Pozzobon⁽¹⁾, Giovanni Gamba⁽¹⁾,
Andrea Dalla Chiara⁽¹⁾, Stefano Montagner⁽¹⁾

Pietro Giordano^(2a), Massimo Crisci^(2a), Werner Enderle^(2b)

David T. Chelmins⁽³⁾, Obed S. Sands⁽³⁾, Bryan W. Welch⁽³⁾,
Carolyn J. Clapper⁽³⁾, James J. Miller⁽³⁾

⁽¹⁾*Qascom Srl, Italy*

^(2a)*ESA-ESTEC, The Netherlands*

^(2b)*ESA-ESOC, Germany*

⁽³⁾*NASA, United States of America*

INTRODUCTION

ESA and NASA have a cooperation related to the demonstration of the value for space users of using dual GNSS system (GPS plus Galileo) receiver compared to use of a single GNSS system (GPS) receiver. For this demonstration a joint ESA-NASA activity has been initiated, based on the use of NASA's SCAN Testbed on-board the International Space Station (ISS). The joint project has several objectives, e.g. generation of GPS and Galileo waveform, evaluation of signal performance, generation of PVT and also generation of a Precise Orbit Determination (POD).

In this context, Qascom, has a contract with ESA for designing a Software Defined Radio Galileo/GPS Receiver for accurate positioning and timing that will be installed and experimented on the International Space Station (ISS) in the Space Communications and Navigation (SCaN) Testbed. The SCaN Testbed is an advanced and integrated communications system and laboratory facility that uses a new generation of Software Defined Radio (SDR) technologies that allows researchers to develop, test, and demonstrate new communications, networking, and navigation capabilities in space.

The GARISS (GALileo Receiver for the ISS) project is an element of the overall ESA-NASA cooperation, started in mid 2016 and has as main objective the development of a Galileo and GPS multi-constellation waveform i.e. the combination of Software and Firmware components for processing the GNSS signals.

The GARISS project is organized in three main phases:

1. Design and Development of the Galileo/GPS waveform for the SCaN Testbed starting from existing Qascom GNSS SDR receiver. The design is limited to the implementation of the single frequency Galileo and GPS (L1/E1 or L5/E5a) receiver even if it has been assessed the feasibility of a dual frequency implementation (L1/E1 and L5/E5a) in the same SDR platform.
2. Qualification and test the Galileo/GPS waveform using "ground systems" available at the NASA Glenn Research Center (GRC). Experimenters can have access to two SCaN Testbed ground based systems for development and verification: the Experimenter Development System (EDS) that is intended to provide initial opportunity for software testing and basic functional validation and the Ground Integration Unit (GIU) that is a high fidelity version of the SCaN Testbed flight system and is therefore used for more controlled final development testing and verification testing.
3. Perform in-orbit validation and experimentation: this phase will consists on the collection of raw data in space, assessment on the quality of the measurements and receiver performances in terms of signal acquisition and tracking and finally the computation of positioning in space (Position, Velocity and Time) and assessment of its performance.

This paper introduces the SCaN testbed architecture and provides a description of the mission with specific focus on the design and development trade-offs. The paper includes a high-level description of the waveform firmware and software architectures and some preliminary results showing the expected performance in space. IQ Samples collected by the SCaN Testbed and provided by NASA have also been processed to demonstrate the feasibility of the acquisition design. The paper concludes with an overview of the integration approaches describing the main technical challenges of this phase and the prototype boards that have been selected for the verification.

THE SPACE COMMUNICATIONS AND NAVIGATION (SCAN) TESTBED ARCHITECTURE

The SCaN Testbed includes of a Flight System and a Ground System, and for the experiments purposes makes use of space and ground data network assets, [1]. The SCaN Testbed payload is resident on ExPRESS Logistics Carrier 3 (ELC3) on an exterior truss of the International Space Station (ISS) and has been launched and installed in 2012. The

testbed consists of reconfigurable and reprogrammable Software Defined Radio (SDR) transceivers/transponders operating at S-band, Ka-band, and L-band, along with the required RF/antenna systems necessary for communications. As in the world of communication, software-defined radio (SDR) technology is interesting because it provides the opportunity to develop a platform that is adaptable to unforeseen space mission needs. NASA has deployed the SCaN Testbed to verify how SDR technology including SW design, development, verification and operation processes that can be adopted in future mission, [3].

The SCaN test Bed include three SDRs: Harris SDR, General Dynamics (GD) SDR and the Jet Propulsion Laboratory (JPL) SDR. The SDRs have S-band duplex Radio Frequency (RF) links directly with the ground, also referred to as the Near Earth Network (NEN), S-band duplex RF links with the Tracking and Data Relay Satellite System (TDRSS), also referred to as the Space Network (SN), Ka-Band duplex with TDRSS, and L-Band receive-only link for the Global Navigation Satellite signals. The architecture diagram is shown in Figure 1.

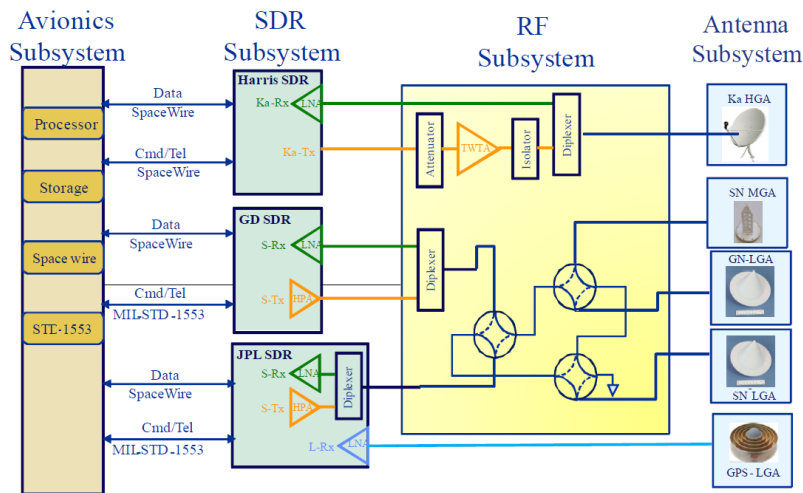

Figure 1 SCaN Testbed High Level Architecture

Each of the Software Defined Radios has an Operating Environment (OE), which includes an operating system and provides infrastructure services to applications and waveforms in accordance with the Space Telecommunications Radio System Standard (STRS).

The SDR used in for the GARISS experimentation is the JPL SDR, for a detailed description see [3]. The elements of the JPL SDR used for the scopes of the project include the following elements:

- **GNSS Antenna:** the GNSS signals are received through a Dorne & Margolin DMC146-6-1 passive antenna with a choke ring, [4].
- **Front End:** the front is designed to directly sub-harmonically samples the filtered GPS L-band signals at L1 (1575.42 MHz), L2 (1227.6 MHz), and L5 (1176.45 MHz) The GNSS signals are filtered against interference, amplified, split, and fed into three channels: L1, L2, and L5. In each of these channels the front end performs the analog to digital conversion at a clock rate of 38.656 MHz, [5].
- **SDR Platform:** the platform includes
 - two FPGAs: Xilinx Virtex II with accompanying volatile and non-volatile memory resources
 - a baseband SPARC processor, supporting an RTEMS operating system

STRS DEVELOPMENT FRAMEWORK

The Galileo waveform will be developed on the STRS framework. The STRS was initiated by NASA to define a standard architecture for space-qualified radios in support of future NASA missions, [7].

The STRS architecture separates the STRS operating environment (OE) from the waveform applications. The OE middleware abstracts the SDR hardware from the waveform application software. Moreover it manages the functions within the SDR, such as: command and telemetry, inter-process communications among software elements, control functions such as loading and unloading the waveform from memory and execution of the waveform.

User applications access the RTOS (Real Time Operating System) of the operating environment through a POSIX (Portable Operating System Interface for Unix) interface and the waveform access remaining OE functions through a set of APIs (Application Programming Interfaces) defined by the STRS architecture (STRS APIs). Once a user waveform application is loaded on a platform, the POSIX and STRS APIs provide the software interfaces to the underlying hardware. On the firmware interfaces within the FPGA, the STRS standard calls out requirements for FPGA signal abstractions between the application and the platform hardware provided by the platform.

The radio functions are distributed among different modules that according to the STRS nomenclature are:

- **Signal Processing Module (SPM):** this module represents the FPGA and it is intended to implement signal processing functions. The SPM will implement the high rate waveform application components
- **General-purpose Processing Module (GPM):** this module represents the microcontroller and it is intended to execute the low rate signal processing waveform component and the managing SW.

The STRS Standard allows the developers to prepare waveform software and firmware that is modular, portable, reconfigurable, and reusable.

GALILEO WAVEFORM DESIGN

The GARISS Waveform design include the following two main components:

- **Waveform Software (WSW):** this is the software dedicated to GNSS signal processing, navigation solution and interface with the Ground (Telemetry and Telecommand) that will run on the SPARC processor. As shown in the basic scheme of the Software architecture in Figure 2 the WSF is organized in the following four modules:
 - Receiver Manager (RM): in charge of managing the communication with the Ground Interface including the processing of the configuration files and the preparation of the Telemetry Data. Moreover it configures and monitor all the other SW modules.
 - Signal Processing Manager (SPM): that controls the acquisition and tracking channels and manages the communication with FPGA to collect correlation values and to control the NCOs
 - Navigation Messages Manager (NMM): that is responsible for the collection, decoding and interpretation of related fields of the received navigation messages.
 - Navigation Manager (NM): that performs the computation of the raw measurements (Pseudorange and Carrier Phase) and the PVT. The module includes also satellite visibility prediction functions to support the Warm Start Acquisition.
- **Waveform Firmware (WFW):** this is the firmware, dedicated to GNSS signal processing that will run on one of two of the XILINX FPGAs. The functionalities allocated to the FPGA are:
 - Clock Management
 - Parallel Correlation for Acquisition (one channel)
 - Serial correlation for Tracking (up to six channels for Galileo and six channels for GPS)
 - Carrier and Code Phase Integrators
 - Spreading Code Generator
 - Numeric Controlled Oscillator (NCO)
 - Noise Floor estimation

In addition, the following external SW will be developed Ground Monitoring and Control SW (GMCSSW): this is a SW engine operated on ground in charge to collect all the data from the Waveform (Telemetry) and prepare the Waveform configuration including aiding data.

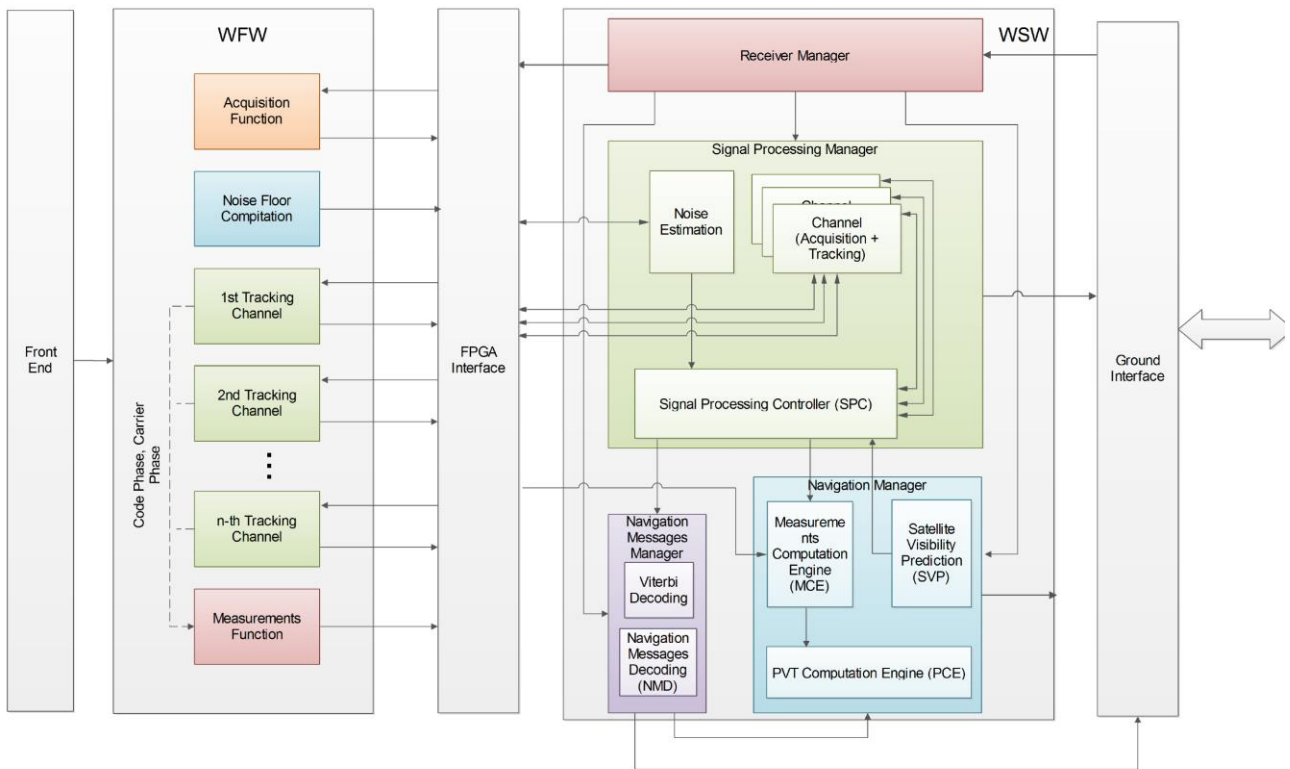

Figure 2 Waveform High Level Architecture

The Waveform Software (WSW) state model has the state machine, shown in Figure 3 that includes the following states:

- **START**: the module is initialized with empty structures. In this state the WSW waits the configuration provided by the ground interface.
- **CONFIGURE**: the WSW is configured using the configuration received from ground.
- **RUN**: the WSW is running in nominal conditions.
- **ERROR**: when an error occurs in START, CONFIGURE or RUN states the WSW switches to this state. In this state, the WSW tries to solve the error otherwise it switches to the SHUTDOWN or hardware reset.
- **SHUTDOWN**: the WSW is switched off in the correct mode. The receiver manager stops the threads, it removes the configuration and it deallocates the memory.
- **HARDWARE RESET**: the receiver is switched off. This procedure is performed calling a specific API of the STRS

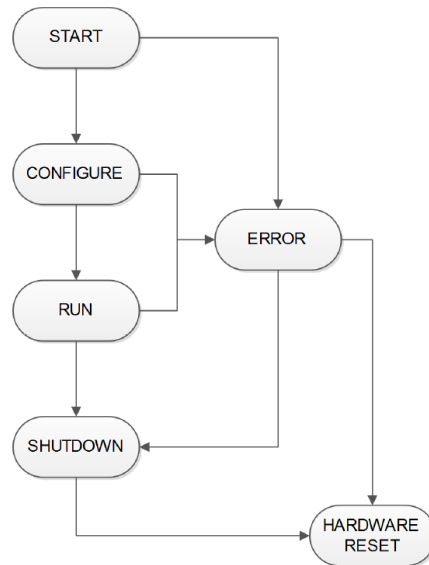

Figure 3 Software High Level State Machine

The waveform has two different Interfaces with the ground segment:

- **Configuration Interface:** the configuration interface is used to configure the processing of each module of the waveform and to upload aiding data for signal acquisition. The aiding data that will be sent are the Ephemeris for GPS satellite and Galileo satellites, the GGTO Data and the SCaN Test Bed orbital data defined Two Line Element (TLE) format. Timing information is provided by via STRS API.
- **Telemetry Interface:** the waveform output data are sent to ground segment using the Telemetry interface. The packets contains tracking, navigation message and PVT data. Different levels of granularity are supported. A binary protocol is used and a maximum of 150 MB of data per day is expected to be produced.

One of the most critical aspects of the Waveform design is the Signal Acquisition: the Doppler search window is very wide (± 35 KHz) and GNSS satellites are in view to the GNSS L Band antenna only for few minutes. Therefore, during operations, the selected baseline acquisition mode is the Warm Start. This has been implemented in an innovative way for a space receiver as the availability of the Ground to SCaN Test Bed communication link allows to transmit to the Waveform aiding data (satellites ephemerides, and SCaN Testbed TLE). Moreover, the waveform can retrieve the GPS time from the ISS through the Avionics subsystem. Aiding data also used to generate the PVT, in the first version of the waveform, without extracting the navigation information from the Signal In Space.

PERFORMANCE TRADEOFFS

In parallel to Waveform design Qascom is also performing an extensive assessment of which are the achievable GNSS processing performance in space. As part of this activity, simulated and real data collected on the SCaN Test bed have been used. These results are also supporting the feasibility of dual frequency (L1 and L5) waveform implementation. Dual Frequency is highly beneficial in particular for Precise Orbit Determination (POD) experimentations. The first part of the assessment is based on the processing of the dual constellation (GPS and Galileo) scenario data, generated by means of a GSS6700 Spirent Simulator. These measurements, as seen by the L band Scan Testbed antenna, have been used as input for Satellite Visibility and PVT availability analyses and for the estimation of the range of Doppler and Doppler rate variations. The following main assumptions have been used in the analysis configuration:

- GPS Constellation Status in mid-2017:
 - 31 Satellites transmitting L1CA signal
 - 12 Satellites (IIF block) transmitting L5 signal
- Galileo Constellation Status in mid-2017:
 - 16 Satellites transmitting E1 signal
 - 15 Satellites transmitting E5a signal
- SCaN testbed L band antenna field of view is above 30 degrees, [6]

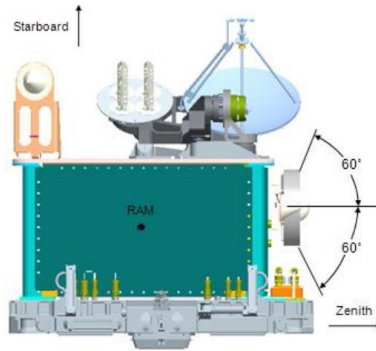

Figure 4 L Band Antenna Field of View

The following parameters have been considered for the satellite visibility and PVT availability analysis.

- *Average Time of Satellite Visibility*: that is the average period of time in which a satellite is in visibility of the L Band Antenna with an elevation higher than 30 degrees
- *Mean Number of Visible Satellites*: that is the average number of satellites that are in visibility of the L Band Antenna
- *PVT Availability*: represent the percentage of time over the experiment duration in which the PVT can be computed (i.e. at least 4 satellites are in view)
- *Average Time for Four Satellites*: represents the average time in which there are at least four satellites in view that can be used to compute the PVT.

The Table 1 summarize the visibility and PVT availability results for each single signal:

Parameter	GPS L1CA	Galileo E1	GPS L5	Galileo E5a
Average Visibility Time	20.6 min	20.1 min	20.29 min	20.07 min
Average Number Of Visible Satellites	4.9	2.23	1.66	2.18
PVT Availability	92.5 %	12.41 %	0.37 %	11.34 %
Average Time Four Satellites	28.35 min	4.47 min	54.1 sec	4.67 min

Table 1 GPS and Galileo Visibility and PVT Availability Analyses

This analysis has shown that there are on average more satellites in L1/E1 than L5/E5a (as expected) and therefore during the experimentation phase it is more “probable” to compute a PVT using L1/E1 than L5/E5a. In addition, for the Waveform single frequency implementation a dual constellation (GPS and Galileo) is mandatory in L5/E5a case for generating a PVT considering the low availability of GPS and Galileo only L5/E5a signals.

In summary:

- PVT Availability is 99.7 % for L1/E1 and 64.8% for L5/E5a
- the Average Time for Four Satellites is 6 hours for L1/E1 and 12 minutes for L5/E5a

As already stated, one of most critical part of the signal processing is the Signal Acquisition. To support the definition of the Waveform acquisition engine (algorithms, thresholds and acquisition modes) the following analyses have been carried out:

- Analysis of the Doppler and Doppler Rate of the satellites in view to the L Band Scan Test Bed antenna. These values has been used, for example, to define the width of the acquisition search space.
- Link Budget versus Elevation taking into account the L Band Antenna Pattern, the Antenna Noise Temperature and the LNA noise figures provided by NASA. These results has been used to tune the acquisition thresholds in Cold and Warm start modes.

The following Table 2 reports the results of the analyses for the four signals. In Figure 5 it is shown the profile of the Doppler and Doppler rate of Galileo E1 signals for a simulation of 300 minutes. Figure 6 reports the CN0 profile for Galileo E1 and Galileo E5a: the green area represent the field of view of the L band antenna. As expected the CN0 is quite high above 30 degrees elevation, allowing short acquisition times even in Cold Start.

Parameter	GPS L1CA	Galileo E1	GPS L5	Galileo E5a
Doppler Max / Min	36.05KHz	33.39 KHz	26.92 KHz	25.26 KHz
	-35.90 KHz	33.84 KHz	-26.78 KHz	-25.53 KHz
Doppler Rate Max / Min	-19.92 Hz/s	-20.93 Hz/s	-14.93 Hz/s	-15.89 Hz/s
	-65.98 Hz/s	-60.40 Hz/s	-49.28 Hz/s	-45.63 Hz/s
CN0 (30 deg)	45 dBHz	44 dBHz	46 dBHz	46 dBHz

Table 2 Doppler and Link Budget Analyses

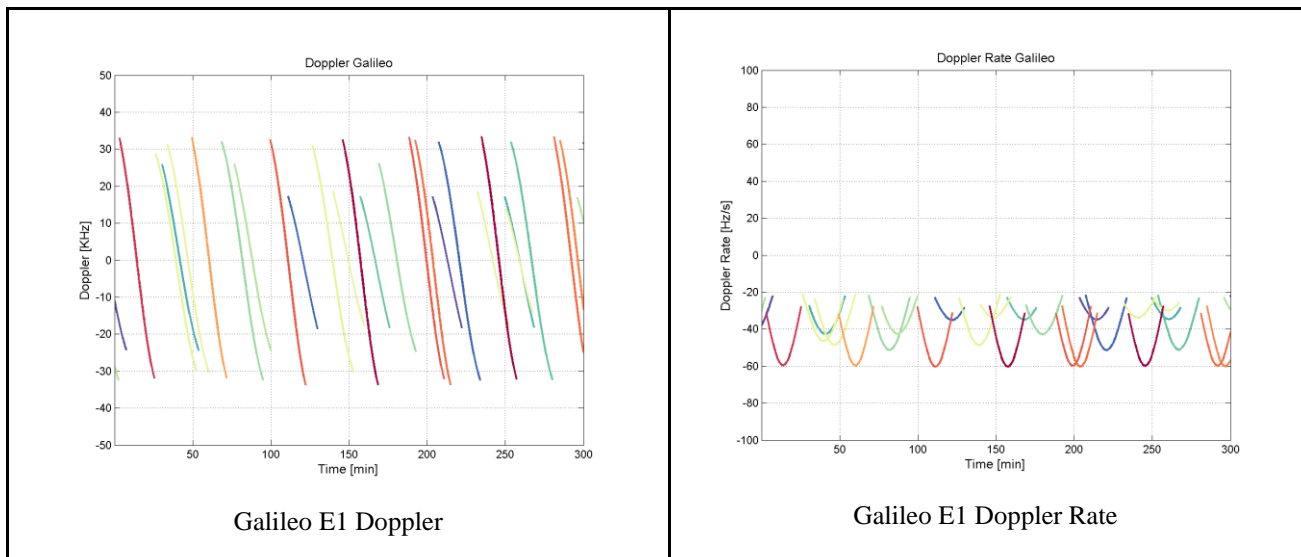

Figure 5 Doppler and Doppler Rate profile for Galileo E1

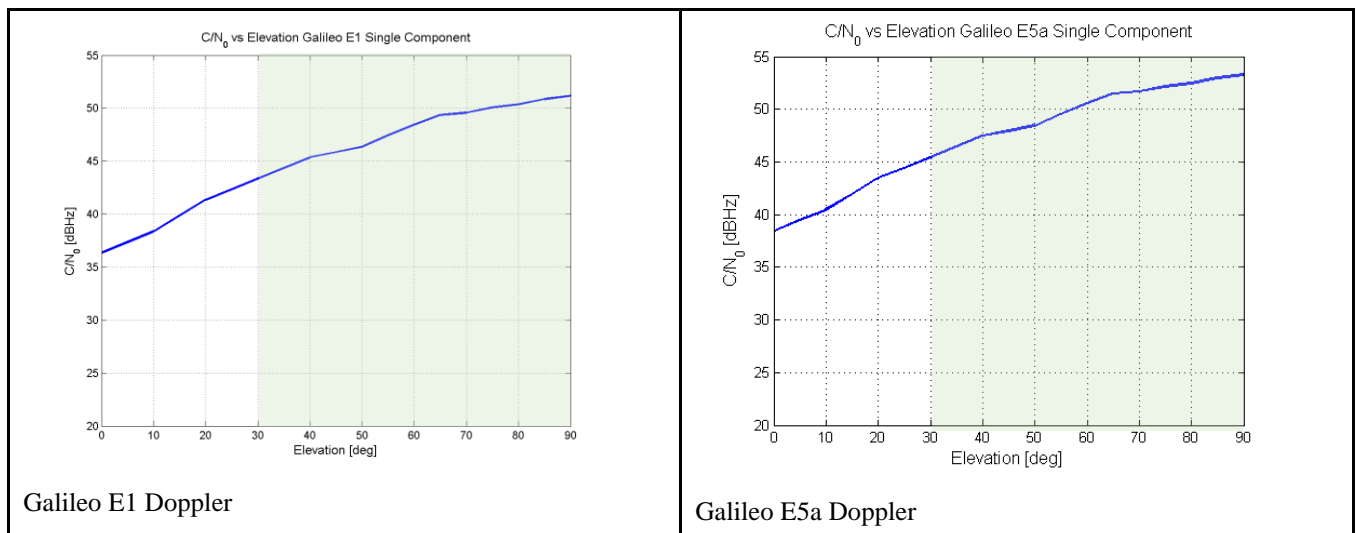

Figure 6 C/N0 versus Elevation for Galileo L1 Galileo E5a

Finally, real IQ data collected (in 2013) on the SCaN testbed have been used in order to validate the acquisition processing of the Waveform. The following Table 3 reports the results of Galileo and GPS signal acquisition in L1/E1 and L5/E5a. A detailed view of Galileo E1 signal acquisition for PRN 19 is shown in Figure 7. This specific satellite has been acquired with C/N0: 50.03 dBHz, Code Phase: 5.996171e-03s and Doppler: +5560.9 Hz.

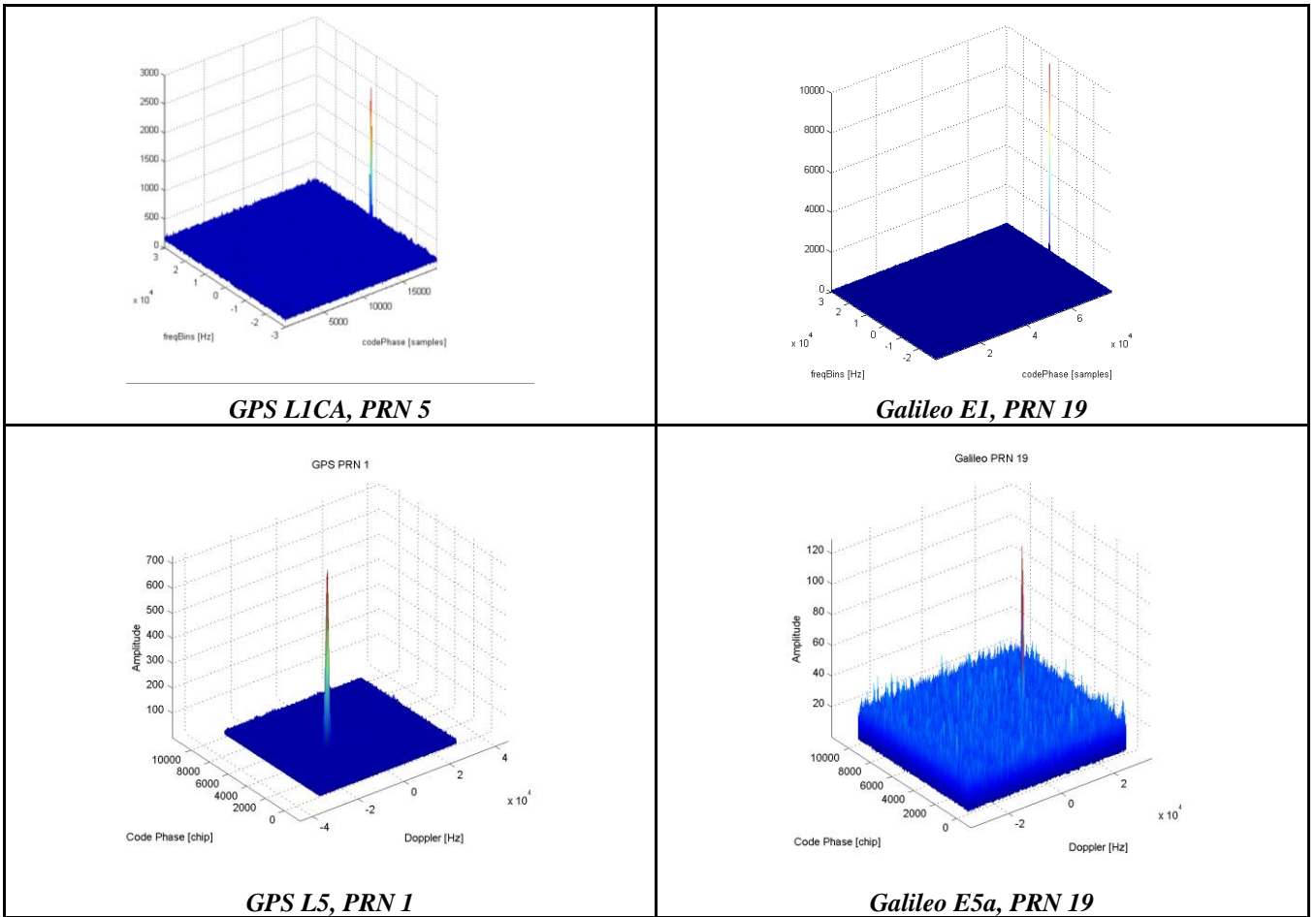

Table 3 First Signal Acquisitions in L1/E1 and L5/E5a using ScaN Test Bed IQ samples

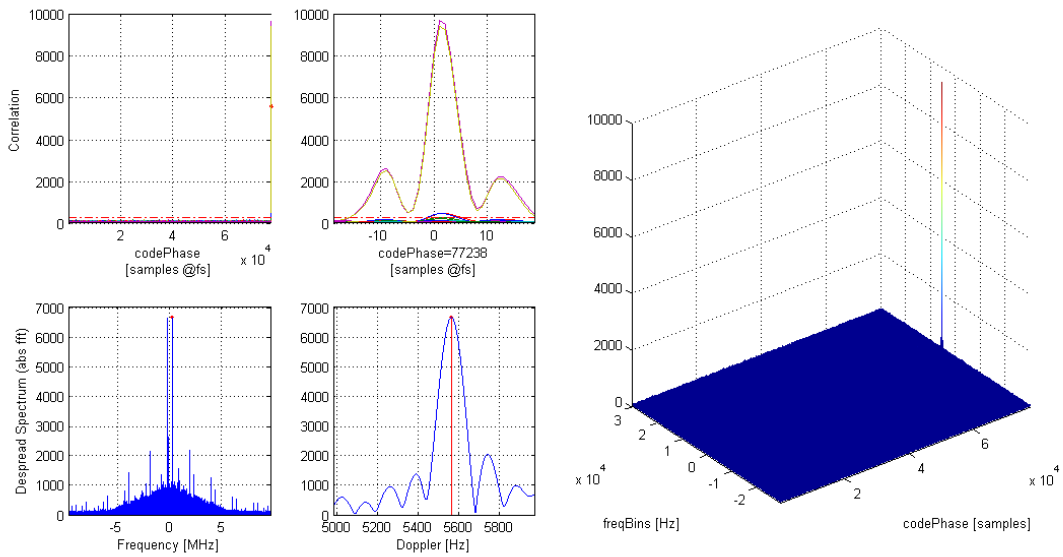

Figure 7 Galileo E1 (PRN 19) Signal Acquisition

VALIDATION AND EXPERIMENTATION APPROACHES

The following three test Phases are foreseen for the GARISS project:

- Unit Level Testing: this type of tests will be executed for each of the two component of the Waveform (WSW and WFW). The Testing will be executed at Qascom premises using selected boards that are representative of the JPL SDR hardware.
- System Level Testing: this testing phase will be executed at NASA premises. The objective is the verification of the integrated waveform components. Two integrated systems are available: the Experiment Development System (EDS) and the Ground Integration Unit (GIU) as defined in the experimenter Handbook, [3]
- Experimentation: this activity consists in the in-orbit validation and experimentation of the Waveform.

One of the major challenges of the GARISS project is due to the fact that a prototype of the JPL SDR platform is not available in Europe (at Qascom or ESA premises). In addition, at unit level it will not be possible to test the “closed loop” and the interactions between the SW and the FW. Therefore, some strategies have been proposed to overcome this limitation. The following test architecture is proposed for the WFW verification:

- Virtex II Pro Development Board including a Xilinx XC2VP30 FPGA where the Waveform Firmware is loaded
- Cypress EZ-USB FX3, or other device: this is a super speed peripheral controller that will be used to stream, via USB the samples from the PC to the FPGA development board.
- ISS IQ Scenario File: this is an IQ file containing signals generated by Spirent constellation simulator. The files will dump the RF output of the constellation simulator in a realistic ISS scenario.

To test the main functionalities, such as the correlation, the selected approach consist in using a simple scenarios with satellite with known and constant Doppler and code phase that allow to set a static configuration avoiding run time interaction between SW and FW.

The following test architecture is proposed for the Software verification:

- Semi Analytic Signal Generator: this will be used to replace the FPGA in the generation of the correlation values. It will be connected to the beagle bone board, where the waveform SW is running, through a serial link.
- DSP Board: this will be used in replacement of the AT697 Microcontroller and will be used to run the Waveform SW. It will provide to the Semi Analytic Signal Generator feedbacks such as the Doppler and Code Rate. Alternatively, the SW verification will be done in simulation mode.
- SV Range/Doppler/Power, Motion and Navigation Message Scenario File: these files are output of the Spirent constellation simulator and will be used to generate a realistic scenario in terms of dynamics with the Semi analytic simulator

This architecture will allow verifying the main engines running in the SW and the acquisition and tracking channels state machines. The semi analytic signal generator allows generating signal dynamics starting from the Spirent Scenario.

The System Level Testing phase and the Experimentation are foreseen in 2017.

CONCLUSIONS

The GARISS project has the objective to develop and experiment a multi-constellation Galileo and GPS receiver for the ISS SCaN test bed, in the JPL SDR platform. The paper provides a high level overview of the project tasks and the key elements of the Software and Firmware design. The receiver will implement, in its first versions, a Warm Start acquisition mode exploiting the aiding data that can be provided from ground. A preliminary assessment of the expected range of Doppler and Doppler rate, Link budget and satellite visibility have been provided. The acquisition has been demonstrated using real data captured on the ISS SCaN test bed. The project that currently is in the development phase will allow to experiment the first Galileo signal processing on the ISS.

REFERENCES

- [1] <https://spaceflight systems.grc.nasa.gov/sopo/scsmo/scan-testbed/>
- [2] D. Chelmins, B. Welch, "COMPARING ON-ORBIT AND GROUND PERFORMANCE FOR AN S-BAND SOFTWARE-DEFINED RADIO", IAC-14-B2.8-YPVF.3.10
- [3] NASA SCaN Experimenters Handbook, GRC-CONN-PLAN-5006 Rev A, 6/18/12
- [4] C. B. Duncan, D. E. Robison, C.L. Koelewyn, “Software Defined GPS Receiver for International Space Station”, ION NTM 2011
- [5] <http://www.techbriefs.com/component/content/article/ntb/tech-briefs/electronics-and-computers/13029> NASA Tech Briefs, Connect Global Positioning System RF Module
- [6] SCaN Testbed Flight and Ground System Description, GRC-CONN-DOC-5022 Rev A, 04/26/2012

[7] Space Telecommunications Radio System (STRS) Architecture Standard Release 1.02.1, NASA/TM—2010 216809/REV1 March 2012