



# Microstructural and Material Quality Effects on Rolling Contact Fatigue of Highly Elastic Intermetallic NiTi Ball Bearings

*Christopher DellaCorte, S. Adam Howard, Fransua Thomas, and Malcolm K. Stanford  
Glenn Research Center, Cleveland, Ohio*

## NASA STI Program . . . in Profile

Since its founding, NASA has been dedicated to the advancement of aeronautics and space science. The NASA Scientific and Technical Information (STI) Program plays a key part in helping NASA maintain this important role.

The NASA STI Program operates under the auspices of the Agency Chief Information Officer. It collects, organizes, provides for archiving, and disseminates NASA's STI. The NASA STI Program provides access to the NASA Technical Report Server—Registered (NTRS Reg) and NASA Technical Report Server—Public (NTRS) thus providing one of the largest collections of aeronautical and space science STI in the world. Results are published in both non-NASA channels and by NASA in the NASA STI Report Series, which includes the following report types:

- TECHNICAL PUBLICATION. Reports of completed research or a major significant phase of research that present the results of NASA programs and include extensive data or theoretical analysis. Includes compilations of significant scientific and technical data and information deemed to be of continuing reference value. NASA counter-part of peer-reviewed formal professional papers, but has less stringent limitations on manuscript length and extent of graphic presentations.
- TECHNICAL MEMORANDUM. Scientific and technical findings that are preliminary or of specialized interest, e.g., “quick-release” reports, working papers, and bibliographies that contain minimal annotation. Does not contain extensive analysis.
- CONTRACTOR REPORT. Scientific and technical findings by NASA-sponsored contractors and grantees.
- CONFERENCE PUBLICATION. Collected papers from scientific and technical conferences, symposia, seminars, or other meetings sponsored or co-sponsored by NASA.
- SPECIAL PUBLICATION. Scientific, technical, or historical information from NASA programs, projects, and missions, often concerned with subjects having substantial public interest.
- TECHNICAL TRANSLATION. English-language translations of foreign scientific and technical material pertinent to NASA's mission.

For more information about the NASA STI program, see the following:

- Access the NASA STI program home page at <http://www.sti.nasa.gov>
- E-mail your question to [help@sti.nasa.gov](mailto:help@sti.nasa.gov)
- Fax your question to the NASA STI Information Desk at 757-864-6500
- Telephone the NASA STI Information Desk at 757-864-9658
- Write to:  
NASA STI Program  
Mail Stop 148  
NASA Langley Research Center  
Hampton, VA 23681-2199



# Microstructural and Material Quality Effects on Rolling Contact Fatigue of Highly Elastic Intermetallic NiTi Ball Bearings

*Christopher DellaCorte, S. Adam Howard, Fransua Thomas, and Malcolm K. Stanford  
Glenn Research Center, Cleveland, Ohio*

National Aeronautics and  
Space Administration

Glenn Research Center  
Cleveland, Ohio 44135

## Acknowledgments

The authors wish to thank Steve Miller from NASA Glenn's manufacturing division for his expertise in making test specimens and bearing rig components. His precision fabrication capability has been essential in acquiring meaningful data. Also, Penni Dalton and Janet Hurst of NASA Glenn Research Center are gratefully acknowledged for their continuing project management support of this work. This work was sponsored by the Fundamental Aeronautics Program, NESC and ISS at the NASA Glenn Research Center.

This report contains preliminary findings,  
subject to revision as analysis proceeds.

*Level of Review:* This material has been technically reviewed by technical management.

Available from

NASA STI Program  
Mail Stop 148  
NASA Langley Research Center  
Hampton, VA 23681-2199

National Technical Information Service  
5285 Port Royal Road  
Springfield, VA 22161  
703-605-6000

This report is available in electronic form at <http://www.sti.nasa.gov/> and <http://ntrs.nasa.gov/>

# Microstructural and Material Quality Effects on Rolling Contact Fatigue of Highly Elastic Intermetallic NiTi Ball Bearings

Christopher DellaCorte, S. Adam Howard, Fransua Thomas, and Malcolm K. Stanford  
National Aeronautics and Space Administration  
Glenn Research Center  
Cleveland, Ohio 44135

## Abstract

Rolling element bearings made from highly elastic intermetallic materials, such as 60NiTi, are under development for applications that require superior corrosion and shock resistance. Despite such advantages, compared to steel, intermetallics have been shown to have relatively low rolling contact fatigue (RCF) stress capability in simplified 3-ball-on-rod (ASTM STP 771) fatigue tests. In the 3-ball tests, poor material quality and microstructural flaws negatively affect fatigue life but such relationships have not been established for full-scale 60NiTi bearings. In this paper, 3-ball-on-rod fatigue behavior of two quality grades of 60NiTi are compared to the fatigue life of full-scale 50 mm bore ball bearings made from the same materials. 60NiTi RCF rods with material or microstructural flaws suffered from infant mortality failures at all tested stress levels while high quality 60NiTi rods exhibited no failures at lower stress levels. Similarly, tests of full-scale bearings made from flawed materials exhibited early surface fatigue and through crack type failures while bearings made from higher quality material did not fail at modest stress levels even in long-term tests. Though the full-scale bearing test data is yet preliminary, the results suggest that the simplified RCF test is a good qualitative predictor of bearing performance. These results provide guidance for materials development and to establish minimum quality levels required for successful bearing operation and life.

## Introduction

Nickel rich NiTi based alloys are emerging as a new class of materials for rolling element-bearing applications (Refs. 1 to 3). These intermetallic materials, like 60NiTi (60 wt% Ni and 40 wt% Ti), can be hardened like tool steels to Rockwell C60. 60NiTi exhibits excellent corrosion resistance, is non-magnetic and readily machined. It can also undergo extremely high levels (>5%) of fully elastic deformation. This is in stark contrast to conventional bearing steels that have much lower elastic limits (<1%). Despite its high hardness, NiTi alloys have a relatively low elastic modulus that is typically half that of bearing steel. This combination of elastic properties imparts unusually high dent resistance to concentrated contacts such as those found between balls and races in bearings. For these reasons, NiTi alloys are actively being pursued for highly aggressive corrosive environments and for those applications subject to heavy static loads. Aeronautics systems and space mechanism hardware are likely to require such bearing attributes and indeed make up most of the near term NiTi applications (Ref. 4). Other than their high cost and susceptibility to brittle fracture, rolling contact fatigue stress capability has been identified as potentially limiting their widespread use.

Two prior studies have investigated the rolling contact fatigue behavior of 60NiTi using the 3 ball-on-rod RCF test (ASTM STP 771). In the first test program, 60NiTi test rods were cut from cast and hot rolled plate. The data is presented within a broad introductory paper on 60NiTi for bearing applications (Ref. 1). The RCF performance of the 60NiTi rods was generally poor. Fatigue failure, manifested by the formation of surface pits, occurred in most of the specimens at all stress levels after just a few minutes of testing. In some tests, however, long test times (800 hr) were achieved even at modest stress levels (2.5 GPa). Post-test metallographic analyses of the rod samples showed that the microstructure of 60NiTi rods was flawed. Inclusions, stringers and pores were observed throughout the test samples. Hence, the

uneven RCF performance was attributed to the inhomogeneous microstructure and alternate material fabrication processes were sought to improve performance.

The second RCF test program evaluated the 3 ball-on-rod performance of 60NiTi rods made via powder metallurgy processing (Ref. 5). In that study, the same test protocol used for the cast and hot rolled 60NiTi RCF measurements was applied to RCF rods made via emerging powder metallurgy (PM) processes. The results were bifurcated. PM 60NiTi rods that were of high quality exhibited no failures at the lowest stress levels (1.7 GPa) and only very occasional failures at modest stress level (2.5 GPa). At the highest stresses (3.6 GPa) failure was rapid often occurring in less than 20 hr of run time. Lower quality PM 60NiTi rods made from contaminated batches of powder material showed sporadic failures even at the lowest stress level. Typical material flaws observed included the presence of ceramic particle inclusions and the persistence of prior particle boundaries despite hot isostatic pressing that normally promotes good particle-to-particle diffusion bonding (Refs. 6 and 7). Figures 1 and 2 show such flaws.

Surface microscopy of fatigue damage regions showed evidence of brittle fracture behavior. Examination of the rods via cross-section metallography indicated that fatigue cracks propagated both along the grain boundaries (intergranular) and through the grain boundaries (intragranular). Such fracture behavior is common for low toughness brittle materials like 60NiTi. Key to improved RCF performance, therefore, appears to be a homogeneous microstructure with a minimum of flaws. However, all of the RCF testing performed to date is limited to simplified 3 ball-on-rod specimens, not full-scale bearings. Full-scale bearing fatigue life data is sorely lacking. Hence, the correlation between microstructure, stress and full-scale bearing fatigue remains to be established.

To address this shortfall in understanding, 50 mm bore full-scale ball bearings were fabricated from two quality grades of PM 60NiTi for which 3 ball-on-rod RCF fatigue data had been collected. The bearings are of hybrid design and utilize 60NiTi for the races and silicon nitride bearing balls. Bearing run-times (stress cycles) and ball-race stresses are comparable to the 3 ball-on-rod experiments. The bearing behavior is then compared to the RCF data collected in the simplified 3-ball test. Once correlation is established, the simplified test can be better relied upon for further materials and processing development toward optimizing future bearing materials.

### **Materials and RCF and Bearing Test Specimens**

Material fabrication begins with the production of pre-alloyed powder. The powder is then formed via powder metallurgy processing into ingots that are then shaped, heat-treated and finished into bearing races and fatigue rod specimens. Two slightly different metal atomization processes were used to produce pre-alloyed 60NiTi powder. One process utilizes a ceramic crucible and can result in lower quality product contaminated with ceramic inclusions. The other process avoids the use of any crucible and is the preferred process for producing higher quality powder.

The lower quality 60NiTi powder was atomized in a system that introduced ceramic particle contaminants as shown previously in Figure 1. In this process, nickel and titanium metals are melted in a ceramic crucible and injected through a ceramic nozzle into a chamber filled with argon. Contact of the molten 60NiTi with the crucible and nozzle appears to introduce a small quantity of small ceramic particles into the powder. During later consolidation into ingots, the ceramic particles become hard inclusions in the bulk 60NiTi ingot. These small, faceted inclusions are believed to lead to stress risers and fatigue initiation. The nature of the contaminants is well documented in an earlier paper (Ref. 8). It is to be understood by the reader that at the time of production, it was not known that such contamination had occurred. It was only during RCF and full-scale bearing testing that performance issues arose. The general thermophysical and mechanical properties of the lower quality 60NiTi do not appear to be affected by the small-scale inclusions.

The higher quality 60NiTi powder is made using a specialized atomization system that precludes contact of the molten nickel and titanium with ceramics or metals other than titanium. Designated as the electrode induction melting gas atomization (EIGA) process, this system heats the tip of a solid rod of high purity cast 60NiTi material liberating molten drops of 60NiTi that fall into a high velocity argon gas

stream. The argon stream breaks up the drops into smaller droplets that fall into an argon-filled chamber where they solidify into rounded particles. The interior of the tank and associated piping is made from titanium further reducing downstream contamination. Images of the powder have been previously reported (Ref. 9) and cross-section micrographs of the high quality 60NiTi in the as-received (annealed) and heat-treated (hardened) conditions are shown in Figures 3(a) and (b), respectively.

The 60NiTi (60 Ni and 40 Ti by weight%) is processed by powder metallurgy methods into ingots from which 50 mm bore ball bearings and RCF rods are then fabricated. For the present work, starting powder manufactured by both of the aforementioned atomization processes was obtained and made into ingots using the hot-isostatic pressing method as shown in Figure 4 and generally described by Reference 9. Briefly, the pre-alloyed powder is poured into a well-cleaned, mild steel container that is welded shut and evacuated to remove air and moisture from between the NiTi particles. The can is placed into a high-pressure furnace for consolidation. After consolidation, the ingots are slowly furnace cooled in order to avoid hardening that accompanies rapid cooling.

For the present research, RCF rods and 50 mm bore deep-groove ball bearing races were made from high quality 60NiTi ingots. A combination of wire electrode discharge machining (EDM) and conventional machining with carbide tools is used to make parts in near final dimensions. These rough shaped parts are then heat-treated (1000 °C for 2 hr) in argon then immediately water quenched to attain high hardness (Rc 58-60). The hardened parts are then finished via machining, grinding and polishing to achieve the desired final dimensions and surface finish. Baseline material properties for 60NiTi and, for comparison, other bearing materials are given in Table I. More details on the manufacturing process can be found in the literature (Ref. 8).

### **Fatigue Tests: RCF Rods**

The purpose of this paper is to compare preliminary fatigue life behavior of full-scale 60NiTi bearings to the sub-component (3 ball-on-rod) fatigue performance of rods made from identical batches of material. The sub-component RCF performance has been obtained and reported in the literature (Ref. 5). The following paragraphs review this RCF rod fatigue data and test protocol to facilitate comparison to the full-scale bearing test results.

In the 3 ball-on-rod test, depicted in Figure 5, polished Grade 10 steel bearing balls are loaded against a polished, NiTi rod that rotates at 3600 rpm (Refs. 10 and 11). An oil drip system provides lubrication and an accelerometer is used to monitor vibration. Surface damage, such as the formation of a pit, gives rise to increased vibration that is detected by the accelerometer triggering a halt to the test. If no increase in vibration is detected after 800 hr, indicating no surface damage, the tests are ended and reported as a suspension. Each hour of test time results in the accumulation of approximately one-half million-stress cycles on the test rod.

When rod surface damage and increased vibration is observed in less than 800 hr, the testing is stopped and the load (stress) level reached prior to the current load (stress) is deemed the material's relative stress capability limit. When a test period is concluded at 800 hr without surface damage, the test is stopped and the rod is moved to a new axial location to begin another test at the same load (when conducting repeat tests) or at a higher load (to establish the stress limit). For conventional bearing steels like 440C, the RCF rod stress limit is about 3.5 GPa. For high performance bearing steels like M50, the stress limit for fatigue is much higher (~5.5 GPa).

As shown in Table II, RCF rods made from high quality 60NiTi can endure an operating stress level of 1.7 GPa without failure. At higher stress some tests achieved the 800-hr test time while some failed in less than 1 hr. Rods made from the low quality 60NiTi exhibited infant mortality failures at all stress levels.

Figures 6 to 8 depict typical surface damage in 60NiTi. The failure surface is faceted and reveals the grain structure of the underlying material. It is this type of brittle fracture damage that is expected from full-scale bearings that fail through surface fatigue. Earlier detailed studies showed that the damage mechanism for both high quality and low quality 60NiTi rods is similarly brittle fracture in nature. The main difference is the stress level at which surface fatigue begins.

## Fatigue Tests: Full-Scale Bearings

The 50 mm bore hybrid 60NiTi ball bearings (Fig. 9) are tested to ascertain their fatigue life performance. Since the technology is yet immature, the availability of test bearings is extremely limited. The data presented in this work is preliminary and offers qualitative insight into the fatigue response of 60NiTi. These hybrid bearings are designed for use in a low speed (200 rpm), centrifugal distillation assembly used on the International Space Station as part of the wastewater treatment system (Ref. 8).

The bearings are a deep groove design with a contact angle of approximately 10° to 15°. The bearings operate in a zero-gravity environment and the primary bearing load comes from the axial preload wave spring set at 90 lb (~400 N). Under this load, the peak stress level between the balls and races is approximately 2 GPa. This stress level is comparable to that generated in the 3-ball tests. Based upon the 3-ball test results, it is anticipated that the bearings made from high quality material will run without suffering from fatigue while the lower quality material may show signs of surface fatigue after test. Figure 10 presents the general bearing geometry.

The bearings are evaluated in the test rig shown in Figure 11. Two identical bearings are greased (~30% fill level) and installed into the spindle. The preload is set and rotation is begun. The test rig measures speed and drive torque continuously during the test. The rig rotates the bearing outer races and the inner races rest on a stationary shaft. An accelerometer is mounted on the stationary test rig shaft and is used to monitor any changes in the smooth operation of the bearing during the test. Accelerometer data is collected and stored each hour. Plotting the data over time enables real-time health monitoring. Surface damage arising from a fatigue pit will result in increased vibration amplitudes, particularly at key frequencies (e.g., ball pass frequency).

There are several factors that may impede the correlation between the sub-component 3-ball results and those for the full-scale 60NiTi bearings. The 3-ball test rolls smooth steel balls on the 60NiTi rod surface while in the bearing test smooth silicon nitride balls operate against 60NiTi races. Further, the 3-ball test uses a once-thru oil drip lubrication scheme while the bearing uses water resistant synthetic hydrocarbon grease. Regarding stress cycles, the 3-ball test generates 8600 stress cycles per minute compared to the bearing whose inner race experiences 1470 stress cycles (ball passes) in the same period. Thus the 800-hr 3-ball test period is roughly equivalent to 4700 hr of bearing run-time. In our tests, the bearings are run to 5000 hr (at 200 rpm) or until surface damage as determined by noise and vibration is detected.

## Fatigue Test Results: Full-Scale Bearings

The 50 mm bore hybrid 60NiTi ball bearings made from low quality 60NiTi powder feedstock ran smoothly with low torque for the first 600 hr when they were removed from the test rig, disassembled and inspected. The bearing grease and the surfaces of the races, balls and cages showed no signs of wear or degradation. The bearings were cleaned; reassembled and new grease was added with the intention of running another 600 hr. However, after 560 additional hours of run time, the bearing rig began to emit a low humming noise and mild vibration indicating that bearing damage had occurred.

The bearings were removed, disassembled and inspected. The first visual indication of damage noted during disassembly was grease's color had changed from white to grey. This typically indicates the presence of metallic wear debris particles. After the grease was removed, examination of the races with a 10X eye-loupe revealed that significant surface spallation had occurred.

In the deepest pits, cross-race cracks had begun to form and propagate through the race cross section. Figure 12 shows representative examples of the wear and damage. It is apparent that surface fatigue had occurred after less than 1160 hr, which is equivalent (in ball pass stress cycles) to approximately 200 hr of run time for the 3-ball test. This fatigue life correlates well with the number of stress cycles observed in the 3-ball test (Table II) for the rod material with inclusions.

Next, the ball bearings made from high quality 60NiTi powder were tested under the same operating conditions. These higher quality bearings operated smoothly with low and uniform torque. The test was paused at 1100 hr of run time to allow for a bearing inspection. At that point, the bearing torque and



vibration signatures were essentially equivalent to the beginning of test (BOT) and no internal bearing wear or damage was anticipated. Recall, the bearings made from the low quality material exhibited significant wear and fatigue damage after a similar time period. Figure 13 shows the vibration plot leading up to the 1100-hr inspection point. Upon disassembly it was observed that the bearing wear surfaces appeared as new. No wear track, no surface pits or other damage was noted. Also the cage pockets were unworn and the grease's appearance and consistency were unchanged. The bearings were cleaned, filled with new grease and reinstalled in the test rig.

After operating for 5000 hr, the test was halted because it had achieved the desired number of hours essentially equivalent to the 3-ball test (in terms of ball pass cycles). Again, the bearings were removed, disassembled and inspected. The bearing wear surfaces and the grease appeared as new. No damage was observed indicating that at this stress level the bearing was operating within its capability limits. Figures 14 shows images of the bearings after test.

## Discussions

Results from the 3-ball-on-rod RCF tests suggest a correlation between bearing quality and fatigue stress capability (Refs. 1 and 5). Such a relationship is well established for conventional bearing steels. Diminished fatigue stress capability has been attributed to stress concentrations near hard inclusions, cyclic stress induced crack growth near small pores and residual stress effects (Refs. 12 and 13). Despite decades of full-scale bearing testing and metallurgy investigations, much quantitative uncertainty between bearing fatigue life and material quality remains. It is clear, however, that homogeneous steel microstructures largely free from hard ceramic inclusions are correlated, qualitatively, to long fatigue life at high continuous stress levels.

For NiTi alloys, therefore, it is not surprising that the preliminary findings appear to mirror the fatigue behavior of steel. The 60NiTi bearings made from material with ceramic inclusions exhibited classic rolling contact fatigue failures after approximately 1160 hr of operation under a 2.0 GPa stress. This test duration corresponds to approximately 10.2 million stress cycles on the inner race. This number of stress cycles-to-failure for the full-scale bearing correlates well with the lifetimes observed when testing the same material in the 3-ball configuration. In the 3-ball test, similar stress levels (between 1.7 and 2.5 GPa) yielded, on average, 10.6 million equivalent stress cycles prior to fatigue failure. Thus, there appears to be good fatigue life-stress level agreement between the 3-ball test and the full-scale bearings.

Examination of the fatigue failure sites also suggests a commonality of damage mechanisms between the full-scale bearing tests and the 3-ball tests. The fatigue pits on the RCF rod surface (Fig. 6) and the bearing inner race (Fig. 12(a)) have similar, faceted features indicative of similar damage mechanisms. This is not surprising since the drip fed oil-lubricated rolling contact of the 3-ball test is intended to mimic ball bearings under normal operation (Ref. 11). In practice, to reduce test times, bearing steels are often run in the 3-ball test against roughened steel balls and at extremely high stress levels that can exceed the test material's yield strength. For steel, such an acceleration test protocol is possible because of the ductility of the steel. Similar acceleration (through increased stress and surface roughness) for 60NiTi was discounted early in the current test program as it led to immediate fatigue failures. Most likely, the inability to accelerate the fatigue tests of NiTi bearing materials is due to its intrinsic brittleness. For brittle materials, if the stress exceeds the fracture strength failure is rapid.

There are several positive determinations that can be made from the current work. One is that the simple 3-ball test configuration appears to provide a low-cost and effective means to assess NiTi material fatigue behavior. Thus it can be used to evaluate new NiTi alloys, heat treatment, and surface enhancements prior to the substantial investment (time and money) needed to undertake bearing fabrication and testing. A second positive determination is that the 60NiTi material can be relied upon to provide reasonably long service life as long as it is made from high quality material free from significant inclusions and other flaws and the continuous stress levels are held to modest levels.

## Concluding Remarks

Encouraging conclusions are derived from comparing 3-ball-on-rod RCF test results to those from full-scale bearing tests of two quality grades (low and high) of 60NiTi. One is that long bearing fatigue life is possible provided continuous stress levels are modest (~2 GPa) and the material is largely free from inclusions and other microstructural flaws. Further, the simple 3-ball test appears to yield fatigue response in a similar fashion to full-scale bearings but at much lower cost, run time and specimen manufacturing complexity. This makes the 3-ball test a valuable tool in the development and evaluation of surface treatments, heat treatments and alloy compositional enhancements.

Going forward, additional test results, both from the 3-ball and full-scale bearing tests, should be acquired to improve statistical confidence in the data and to begin to accumulate life-prediction statistics needed to promote the commercialization and use of NiTi based bearing alloys. In addition, newly emerging more complex alloys, such as NiTi-Hf that exhibit more homogenous microstructures, should be evaluated in order to further advance our understanding of these materials.

## References

1. C. DellaCorte, S.V. Pepper, R.D. Noebe, D.R. Hull, and G. Glennon: "Intermetallic Nickel-Titanium Alloys for Oil-Lubrication Bearing Applications," NASA/TM—2009-215646, March 2009.
2. S.V. Pepper, C. DellaCorte, R.D. Noebe, D.R. Hull, and G. Glennon: "Nitinol 60 as a Material for Spacecraft Triboelements," ESMATS 13 Conference, Vienna, Austria, September 2009.
3. C. DellaCorte, R.D. Noebe, M.K. Stanford, and S.A. Padula: "Resilient and Corrosion-Proof Rolling Element Bearings Made From Superelastic Ni-Ti Alloys for Aerospace Mechanism Applications," NASA/TM—2011-217105, September 2012.
4. C. DellaCorte: "Novel Superelastic Materials for Advanced Bearing Applications," Presented at 13th International Ceramics Conference of CIMTECH 2014, Montecatini, Italy, June 8–13. Published in *Advances in Science and Technology*, volume 89 (2014), pp. 1–9, 2014.
5. C. DellaCorte, M.K. Stanford, and T.R. Jett: "Rolling Contact Fatigue of Superelastic Intermetallic Materials (SIM) for Use as Resilient and Corrosion Resistant Bearings," *Tribology Letters*, (2015) 57:26, January 23rd, 2015.
6. M.K. Stanford, F. Thomas, W.A. Wozniak, and T.R. McCue: "Addressing Machining Issues for the Intermetallic Compound 60-NiTiNOL," NASA/TM—2012-216027, August 2012.
7. M.K. Stanford: "Thermophysical Properties of 60-NITINOL for Mechanical Component Applications," NASA/TM—2012-216056, December 2012.
8. C. DellaCorte, and W.A. Wozniak: "Design and Manufacturing Considerations for Shockproof and Corrosion-Immune Superelastic Nickel-Titanium Bearings for a Space Station Application," NASA/TM—2012-216015, presented at the 41st Aerospace Mechanisms Symposium, Pasadena, CA, May 2012.
9. M.K. Stanford: "Hot Isostatic Pressing of 60-NITINOL," NASA/TM—2016-218884, October 2015.
10. D. Glover: "A Ball-Rod Rolling Contact Fatigue Tester," *Rolling Contact Fatigue Testing of Bearing Steels*, ASTM STP 771, J.J.C. Hoo, Ed., American Society for Testing and Materials, 1982, pp. 107–124.
11. M.J. Minter, *Rolling Contact Fatigue Test Assembly*, US Patent #4452065, June 1984.
12. W.A. Glaeser, and S.J. Shaffer: "Contact Fatigue," *ASM Handbook*, Volume 19: Fatigue and Fracture, ASM International, pp. 331–336, 1996.
13. F. Sadeghi, B. Jalalahmadi, T. Slack, and N. Raj: "A Review of Rolling Contact Fatigue," *ASME Journal of Tribology*, volume 131, October 2009.

TABLE I.—THERMOPHYSICAL AND MECHANICAL PROPERTIES OF 60NiTi AND OTHER BEARING MATERIALS

Property	60NiTi	440C	Si <sub>3</sub> N <sub>4</sub>	M-50
Density	6.7 g/cc	7.7 g/cc	3.2 g/cc	8.0 g/cc
Hardness	56–62 Rc	58–62 Rc	<sup>a</sup> 1300–1500 Hv	60–65Rc
Thermal cond. W/m-°K	~9–14	24	33	~36
Thermal expansion	~11.2×10 <sup>-6</sup> /°C	10×10 <sup>-6</sup> /°C	2.6×10 <sup>-6</sup>	~11×10 <sup>-6</sup> /°C
Magnetic	Non	Magnetic	Non	Magnetic
Corrosion resistance	Acceptable (in acids)	Marginal	Acceptable	Poor
Tensile/flexural strength	~1000/1500 MPa	1900 MPa	600–1200 MPa (Bend strength)	2500 MPa
Young's modulus	~90–115 GPa	200 GPa	310 GPa	210 GPa
Poisson's ratio	~0.34	0.30	0.27	0.30
Fracture toughness	~15 MPa/√m	22 MPa/√m	5–7 MPa/√m	20–23 MPa/√m
Max. use temp	~400 °C	~400 °C	~1100 °C	~400 °C
Elect. resistivity	~1.04×10 <sup>-6</sup> Ω-m	~0.60×10 <sup>-6</sup> Ω-m	Insulator	~0.18×10 <sup>-6</sup> Ω-m

<sup>a</sup>Vicker's hardness, Hv, is a scale used for ceramic materials with hardness values beyond HRC 75.

TABLE II.—3-BALL-ON-ROD RCF PRELIMINARY RESULTS  
(Test duration to first detected surface damage or when 800 test hours reached)  
{3600 rpm, steel balls, NiTi rods, oil drip lubrication, 1 hr equals 0.51 million stress cycles}

Rod Specimen	Peak contact stress (GPa)			
	1.7 GPa	2.5 GPa	3.3 GPa	4.1 GPa
PM-60NiTi (High Quality) Avg. Max/Min #Tests	>800*hr N/A 4	291 hr >800/~1 31	3.6 hr 15.4/~1 9	-----
PM-60NiTi (Low Quality-With inclusions) Avg. Max/Min #Tests	192 hr 240/~1 8	220 hr >800/~1 11	47 hr 218/~1 11	-----

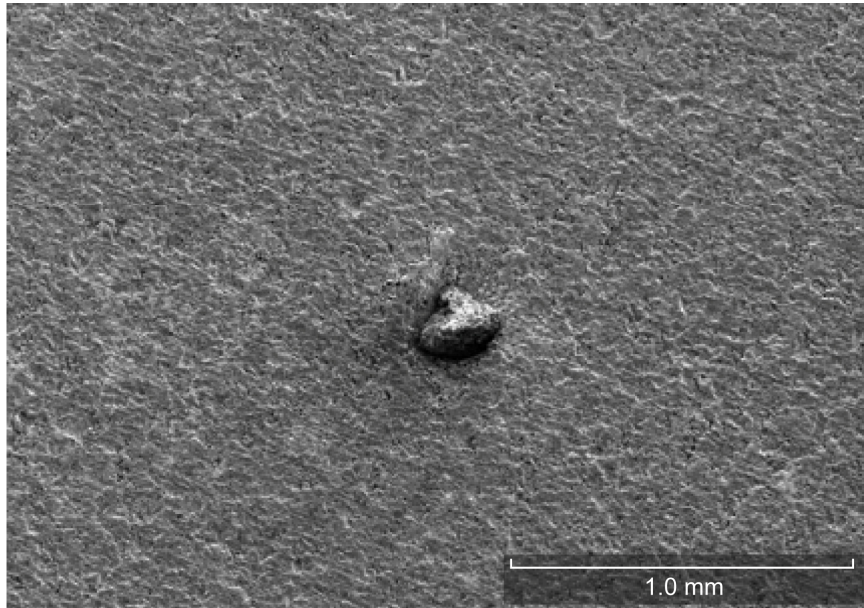

Figure 1.—Ceramic particle inclusions in 60NiTi made by powder metallurgy.

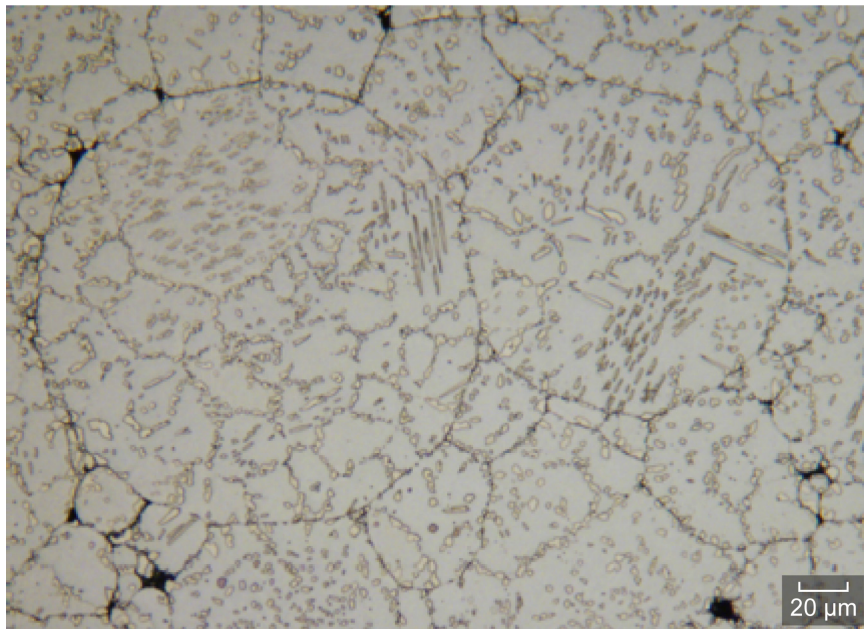

Figure 2.—Unconsolidated particle flaws in powder metallurgy processed 60NiTi resulting from particle surface oxidation.

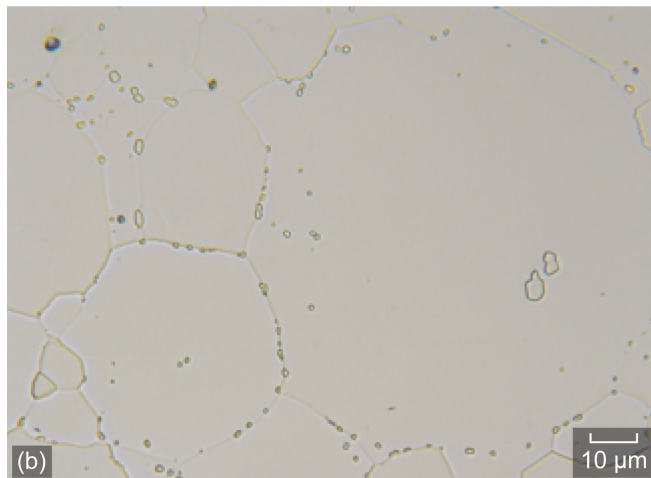
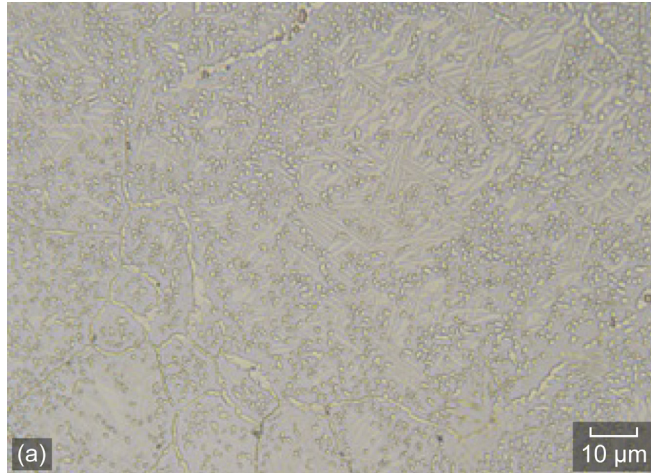

Figure 3.—Metallurgical cross-sections of PM processed 60NiTi: (a) as received, annealed condition, and (b) heat treated, hardened condition. Optical micrographs, acid etched to reveal microstructure.

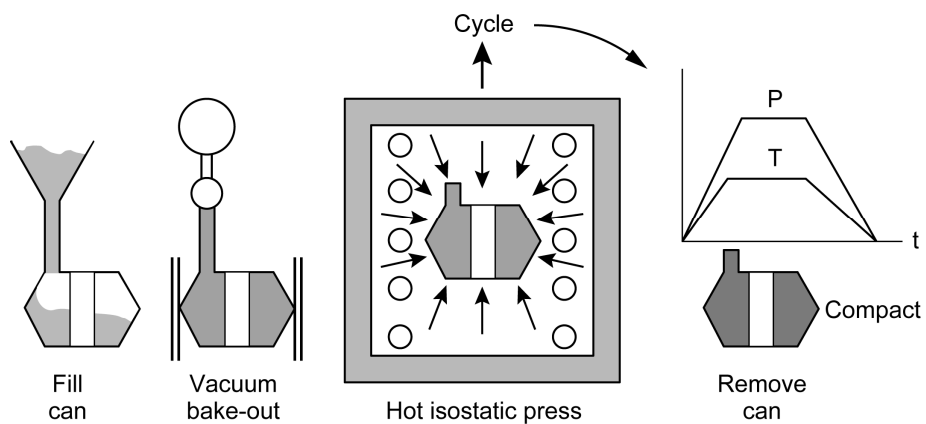

Figure 4.—Powder metallurgy processing route for 60NiTi.

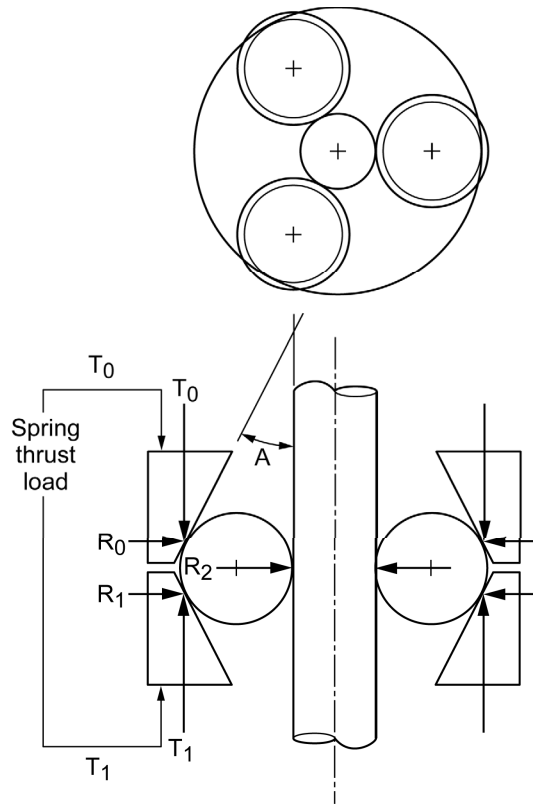

Figure 5.—Sketch of the specimen configuration for the 3 ball-on-rod RCF test.

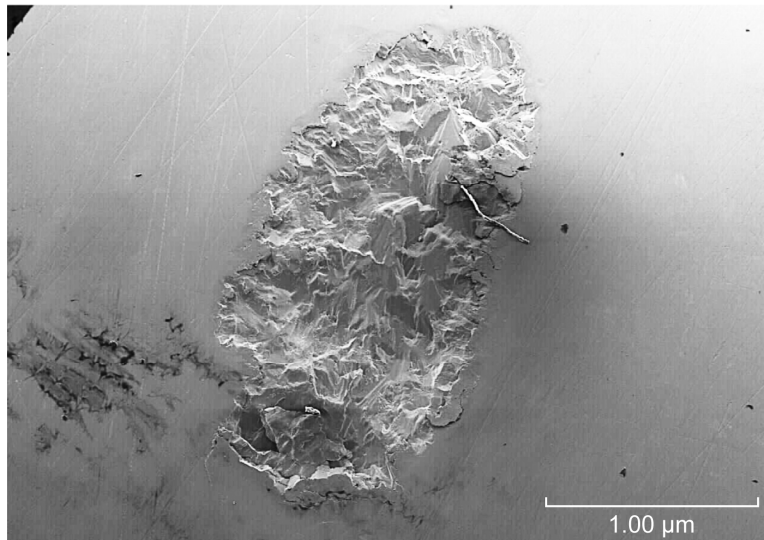

Figure 6.—Scanning electron microscopic (SEM) view of the surface of fatigue spall on PM-60NiTi RCF rod.

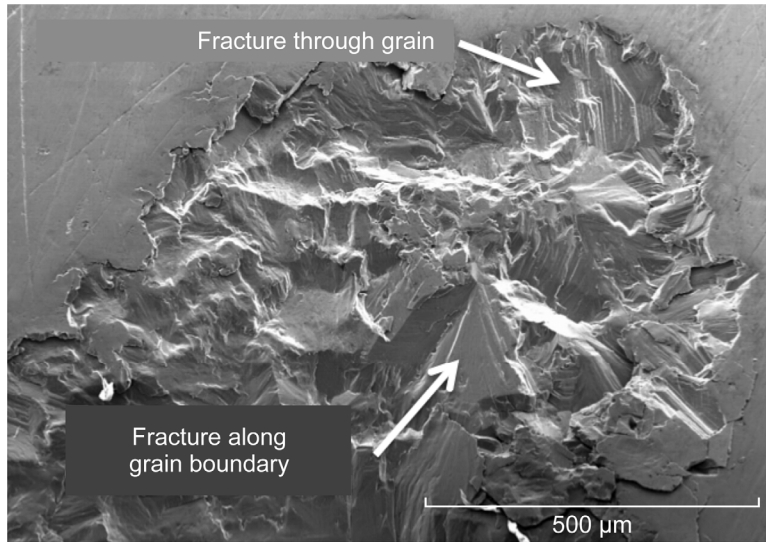

Figure 7.—Close-up surface view (SEM) of initiation damage area of fatigue spall on PM-60NiTi RCF rod.

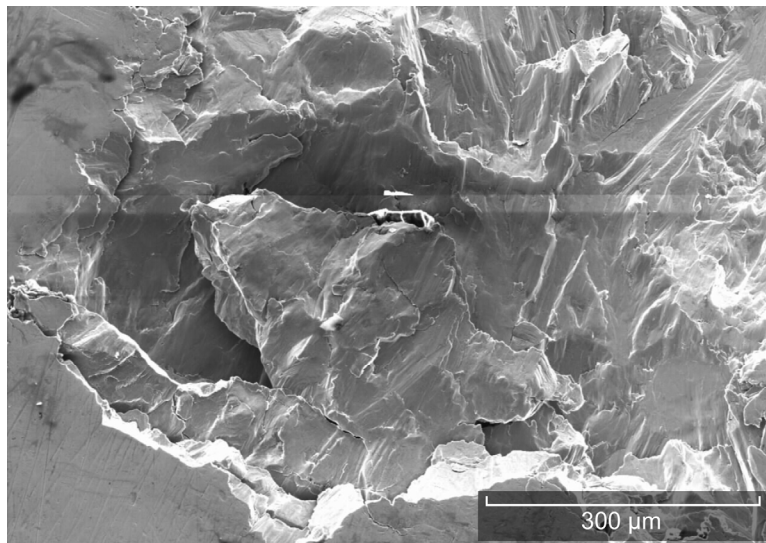

Figure 8.—Close-up (SEM) view of propagating edge of fatigue spall on PM-60NiTi RCF rod.



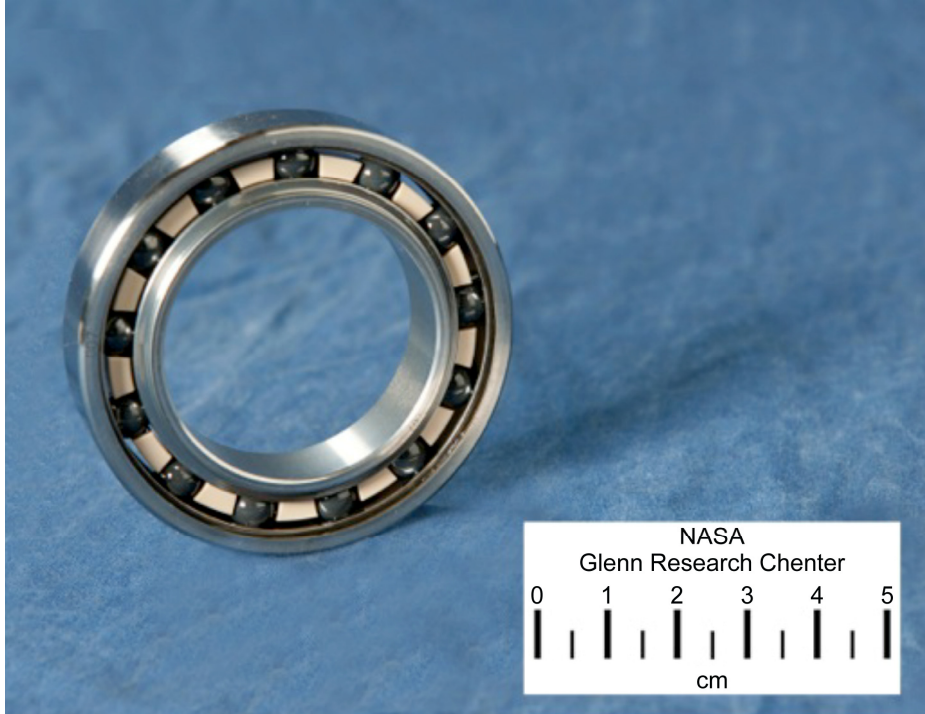

Figure 9.—The 50 mm test bearing with grease shields removed. Hybrid design made with 60NiTi races and Si<sub>3</sub>N<sub>4</sub> balls.

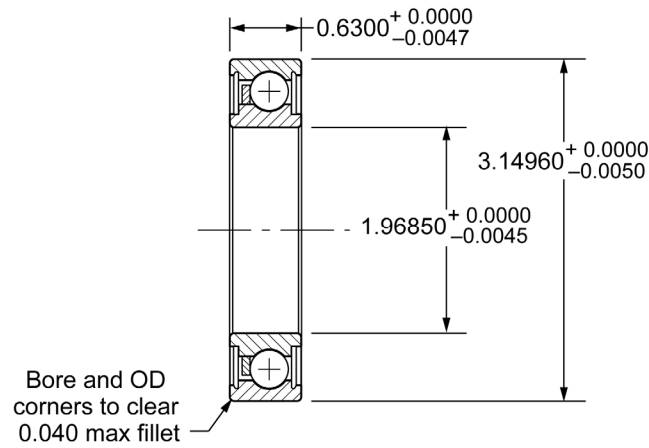

Figure 10.—Test bearing assembly drawing.



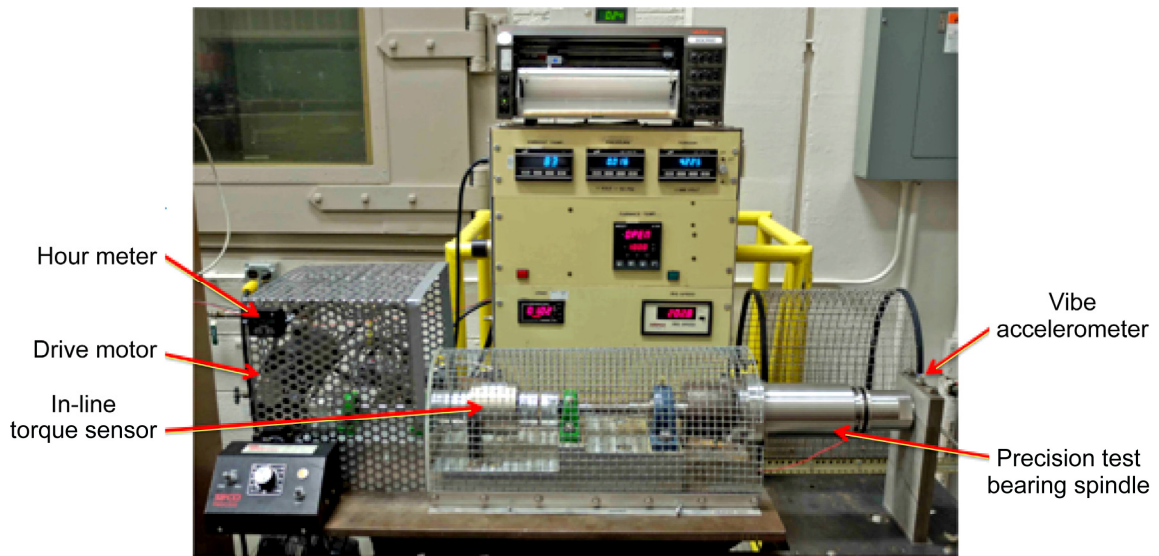
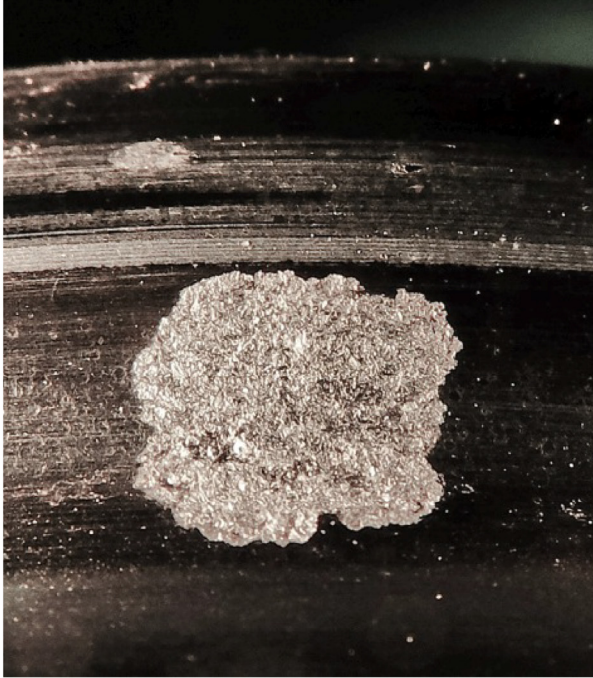

Figure 11.—Bearing test rig.



(a)



(b)

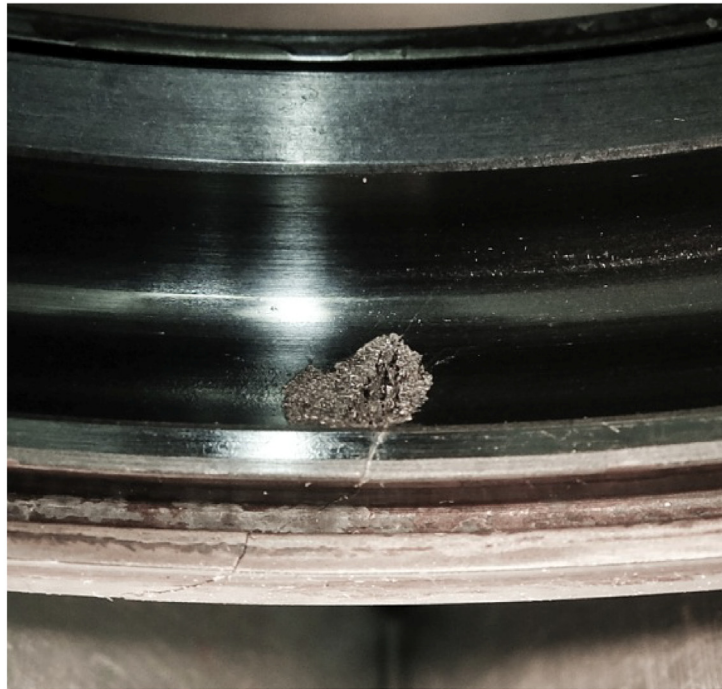

(c)

Figure 12.—Bearing fatigue damage observed in low quality 50 mm bearings after 1160 hr of run time.

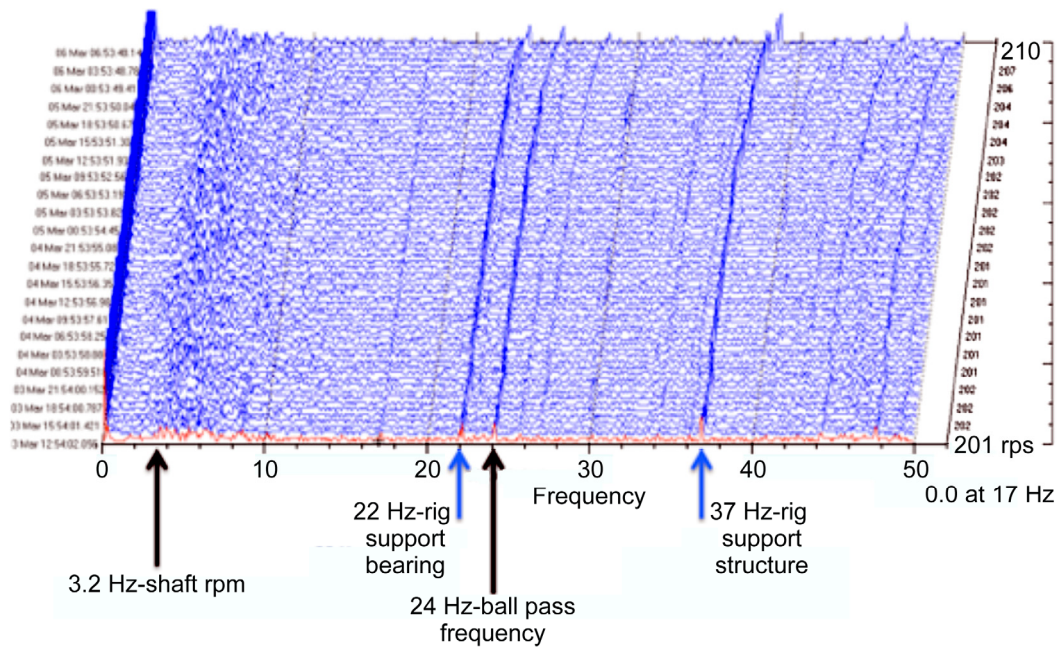

Figure 13.—Cascade plot of hourly vibration spectra (three-day test period) taken during life test of high quality 60NiTi ball bearing.





Figure 14.—Photograph of high quality 60NiTi ball bearing during post-test (5000-hr) inspection in which no grease degradation, wear or fatigue was observed.



