

Total Ionizing Dose Test of Microsemi's Silicon Switching Transistors JANTXV2N2222AUB and 2N2907AUB

M. Campola¹, B. Freeman¹, K. Yau²

1. NASA Goddard Space Flight Center
Code 561.4, Radiation Effects and Analysis Group
8800 Greenbelt Rd
Greenbelt, MD 20771

2. Formerly with AS&D, Inc.

Test Start Date: July 11, 2016
Report Date: March 2, 2017

Table of Contents

1. Introduction	3
2. Devices Tested	3
2.1. 2N222 and 2N2907 Background	3
2.2. Device under Test (DUT) Information	3
3. Test Setup	4
4. Test Description	5
4.1. Irradiation Conditions and Step Stress	5
5. Results.....	6
5.1. 2N2907.....	7
5.2. 2N2222.....	9
6. Conclusion	11

1. Introduction

Microsemi's silicon switching transistors, JANTXV2N2222AUB¹ and 2N2907AUB², were tested for total ionizing dose (TID) response beginning on July 11, 2016. These devices have the Radiation Effects and Analysis Group Identification (REAG ID) numbers 16-021 and 16-022, respectively. This test served as the radiation lot acceptance test (RLAT) for the lot date code (LDC) tested. Low dose rate (LDR) irradiations were performed in this test so that the device susceptibility to enhanced low dose rate sensitivity (ELDRS) could be determined.

2. Devices Tested

2.1. 2N2222 and 2N2907 Background

The 2N2222 is a radiation hardness assured (RHA) three port, high speed switching NPN bipolar junction transistor (BJT) screened to a JANTXV performance level. It is used in high-reliability applications and is suitable for space flight projects.

The 2N2907 is a RHA three port, switching PNP BJT screened to a JANSR performance level. It is used in high-reliability applications and is suitable for space flight projects.

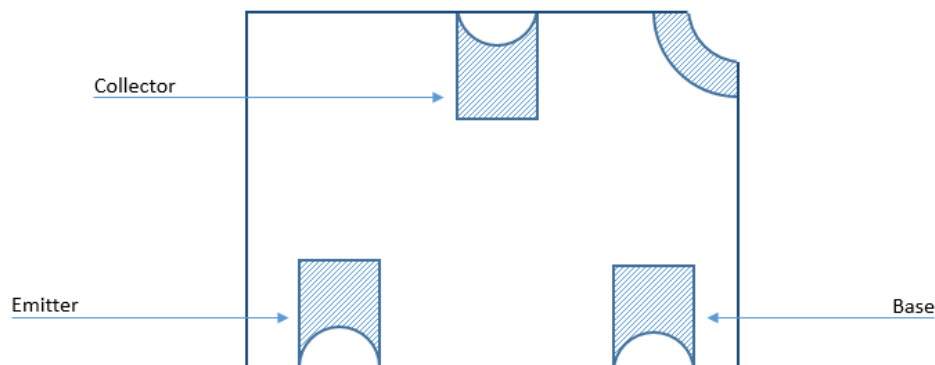

Figure 1: Pin out for 2N2907/2N2222.

2.2. Device under Test (DUT) Information

Twenty devices, ten 2N2222s and ten 2N2907s were irradiated at an average dose rate of 9.61 mrad (Si)/s using a ⁶⁰Co source. An additional two devices of each type were used as controls. Five samples of each the 2N2222s and 2N2907s were irradiated under application specific bias conditions and the remaining five of each type of BJTs were irradiated unbiased with all pins grounded. Both types of DUTs were packaged in a three port UB package which is a ceramic with a metal lid.

¹ Abbreviated as 2N2222

² Abbreviated as 2N2907

Table 1: Part Information

Part Number:	JANTXV2N2222AUB	2N2907AUB
Manufacturer:	Microsemi	Microsemi
Date Code:	WO072694/ R1523 CDWR	T1602
Quantity Tested:	10, Plus 2 Controls	10, Plus 2 Controls
Part Function:	Switch	Switch
Part Technology	BJT	BJT
Package Style	UB	UB

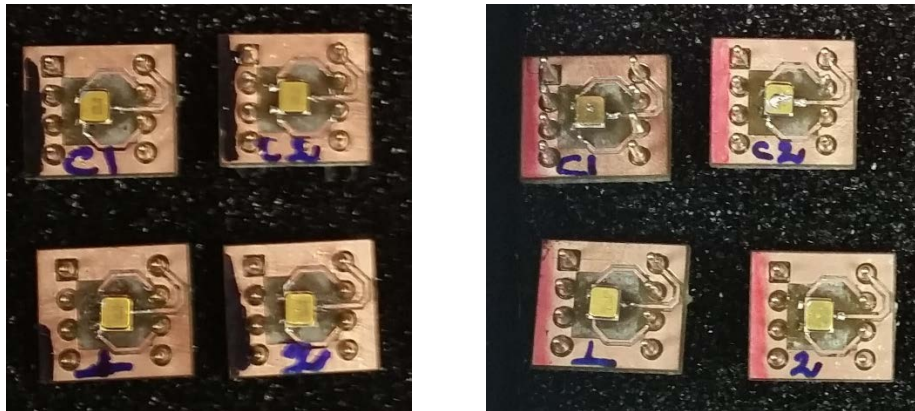

Figure 2: 2N2222 in a UB package (left) and 2N2907 in a UB package (right)

3. Test Setup

3.1. Testing of Microsemi's 2N2222 and 2N2907

The unbiased samples had all leads grounded and the biased sample configuration attempted to simulate the worst-case flight application. Based on current designs, the parts were biased as such:

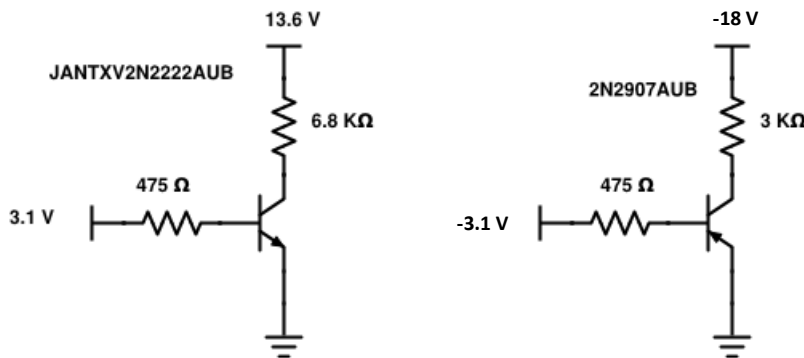

Figure 3: Schematic of BJT biasing

Testing of the 2N2222s and 2N2907s involved placing each BJT on a perforated board with four voltage sources. Source 1 provided base voltage to biased PNPs, source 2 provided collector voltage to biased NPNs, source 3 provided collector voltage to biased PNPs, and source 4 provided base voltages.

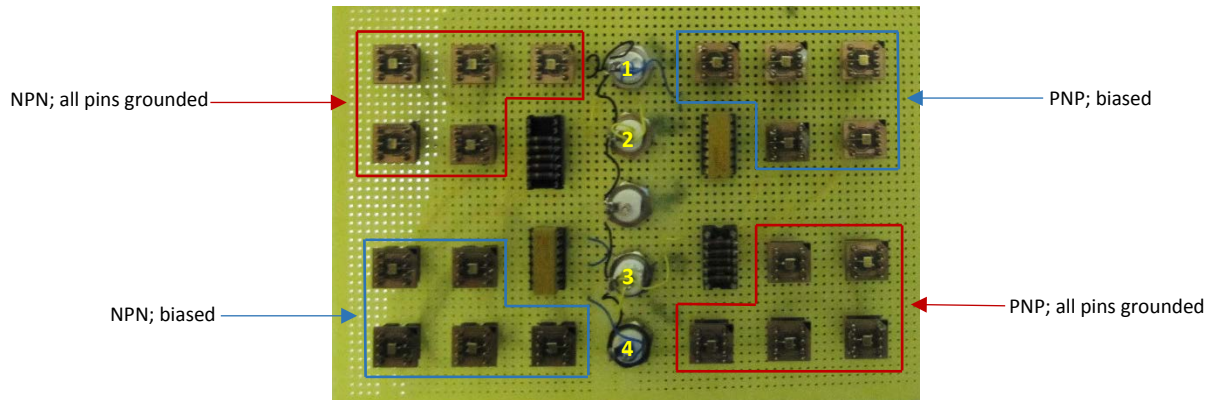

Figure 4: Test Board

In addition, the setup used a Keithley pulse meter and a Keithley source meter connected to a test board containing the DUTs. This was all then connected to a computer with LabVIEW running APAPP 2102.9³.

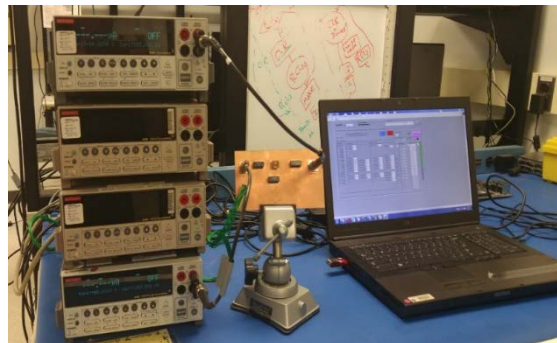

Figure 5: Parameter analyzer setup.

4. Test Description

4.1. Irradiation Conditions and Step Stress

A ⁶⁰CO source, compliant with MIL-STD-883 Method 1019, was used to irradiate the twenty devices at a LDR. The maximum dose rate was 10 mrad (Si)/s. Prior to the first radiation dose, all twenty four BJTs were electrically tested to confirm that they were within the specifications given on each respective data sheet. After each exposure level, given in Table 2, the samples were tested again. Electrical tests performed are given in Table 3.

³ Radiation Effects Analysis Group Software

Table 2: Device Grouping and Step-Stress Instructions

Group	Type	Quantity	Bias	Dose Rate	Exposure Level Steps (krad(Si))
1	2N2222	5	Biased	LDR 10 mrad(Si)/s	0, 1, 2, 5, 10, 15, 20, 30, 45, 55
2	2N2222	5	Unbiased	LDR 10 mrad(Si)/s	0, 1, 2, 5, 10, 15, 20, 30, 45, 55
3	2N2907	5	Biased	LDR 10 mrad(Si)/s	0, 1, 2, 5, 10, 15, 20, 30, 45, 55
4	2N2907	5	Unbiased	LDR 10 mrad(Si)/s	0, 1, 2, 5, 10, 15, 20, 30, 45, 55

Table 3: List of Electrical Tests Performed

Test	Symbol	Conditions $T_A = +25^\circ\text{C}$		Specifications (2N2222)		Specifications (2N2907)	
		2N2222	2N2907	Min	Max	Min	Max
Collector-Emitter Voltage	V_{CE0}			50 V		-60 V	
Collector Current	I_C				800 mA		600 mA
Collector-Base Cutoff Current	I_{CBO}	75 V	60 V		10 μA		-10 μA
		60 V	50 V		10 ηA		-10 ηA
Collector-Emitter Cutoff Current	I_{CES}	50 V	50 V		50 ηA		-50 ηA
Emitter-Base Cutoff Current	I_{EBO}	6.0 V	4.0 V		10 μA		-50 μA
		4.0 V	5.0 V		10 ηA		-10 ηA
Forward-Current Transfer Ratio	h_{FE1}	$I_C = 0.1 \text{ mA}, V_{CE} = 10 \text{ V}$		50		75	
	h_{FE2}	$I_C = 1.0 \text{ mA}, V_{CE} = 10 \text{ V}$		75	325	100	450
	h_{FE3}	$I_C = 10 \text{ mA}, V_{CE} = 10 \text{ V}$		100		100	
	h_{FE4}	$I_C = 150 \text{ mA}, V_{CE} = 10 \text{ V}$		100	300	100	300
	h_{FE5}	$I_C = 500 \text{ mA}, V_{CE} = 10 \text{ V}$		30		50	
Collector-Emitter Saturation Voltage	$V_{CE(sat1)}$	$I_C = 150 \text{ mA}, I_B = 15 \text{ mA}$			0.3 V		-0.4 V
	$V_{CE(sat2)}$	$I_C = 500 \text{ mA}, I_B = 50 \text{ mA}$			1.0 V		-1.6 V
Base-Emitter Saturation Voltage	$V_{BE(sat)}$	$I_C = 150 \text{ mA}, I_B = 15 \text{ mA}$		0.6 V	1.2 V	0.6 V	-1.3 V
		$I_C = 500 \text{ mA}, I_B = 50 \text{ mA}$		0.6 V	2.0 V	0.6 V	-2.6 V

5. Results

Five forward-current transfer ratios were examined for each type of BJT, as well as two collector-emitter saturation voltages. Average values for both biased and unbiased cases have been plotted and contain error bars calculated from K_{TL} , the one-sided tolerance limit. The K_{TL} value for five samples with a worst case of 99% and 90% confidence was 4.666.

Of the twenty-four transistors, the results of twenty-three samples are shown below. The one control for the 2N2907 BJTs became non-operational during testing.

5.1. 2N2907

In Figure 6, Figure 7, and Figure 8, the unbiased BJTs experience more gain degradation than the biased BJTs. This result is consistent with other bipolar devices which experience more degradation when irradiated under unbiased conditions.

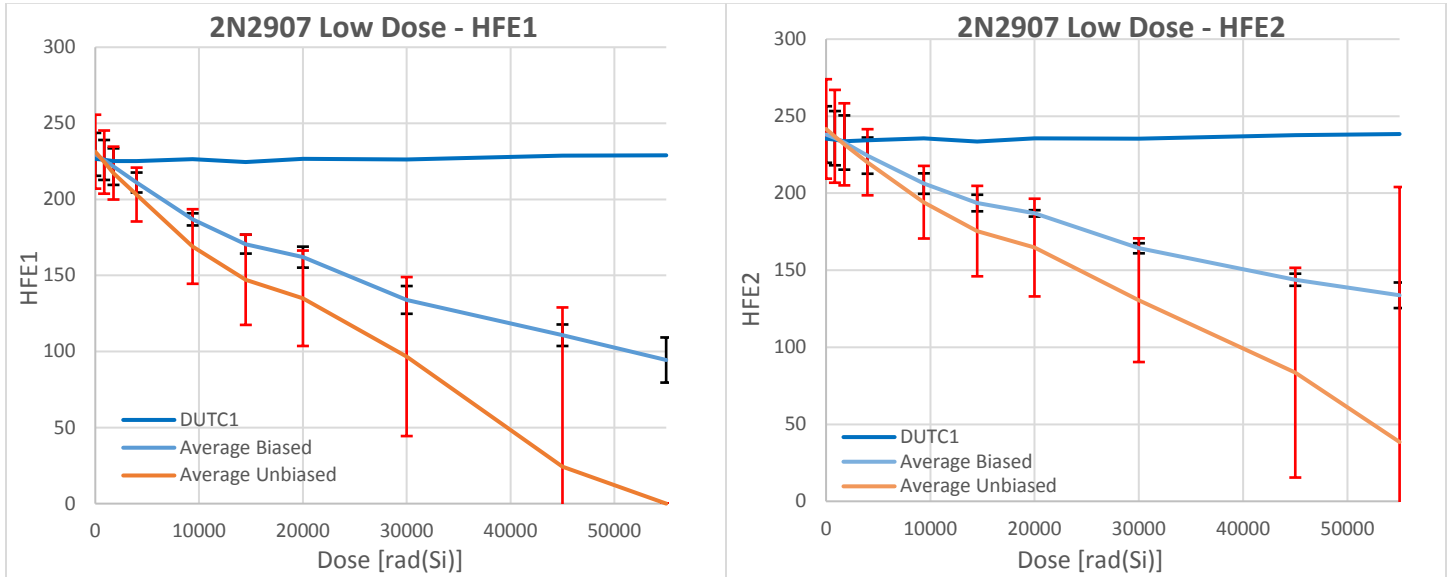

Figure 6: Forward-current transfer ratios 1 and 2

In Figure 6a, the large error bar range was caused by two unbiased BJTs experiencing failure after 45 krad of radiation. In addition, the remaining three units subsequently ceased to function after experiencing 55 krad. In Figure 6b, two unbiased samples did not have a gain at 55 krad. Evidence of bimodality is negligible under 30 k rad. In both figures, the five biased units did experience some gain degradation, but these differences were not as significant as in the unbiased case.

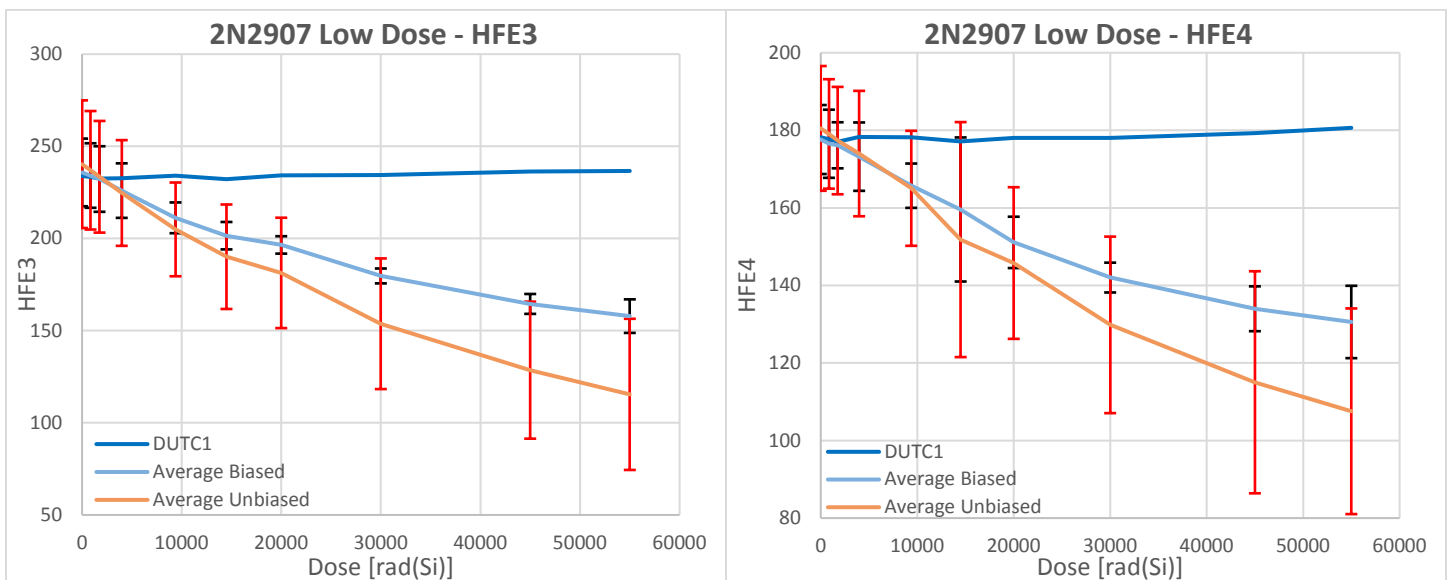

Figure 7: Forward-current transfer ratios 3 and 4

In Figure 7b, the fourth ratio experienced the largest error bars for the biased case with a range of up to ± 30.3 .

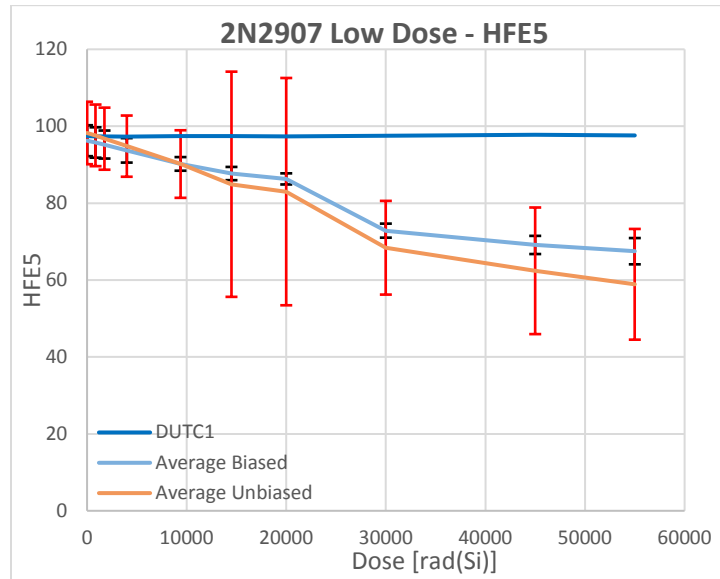

Figure 8: Forward-current transfer ratio 5

Of the five forward-current transfer ratios, ratio 1 the biased and unbiased cases had the smallest difference in results.

With the exception of ratios 1 and 2, the gain of the 2N2907s stayed within the range given in Table 3 up to 55 krad.

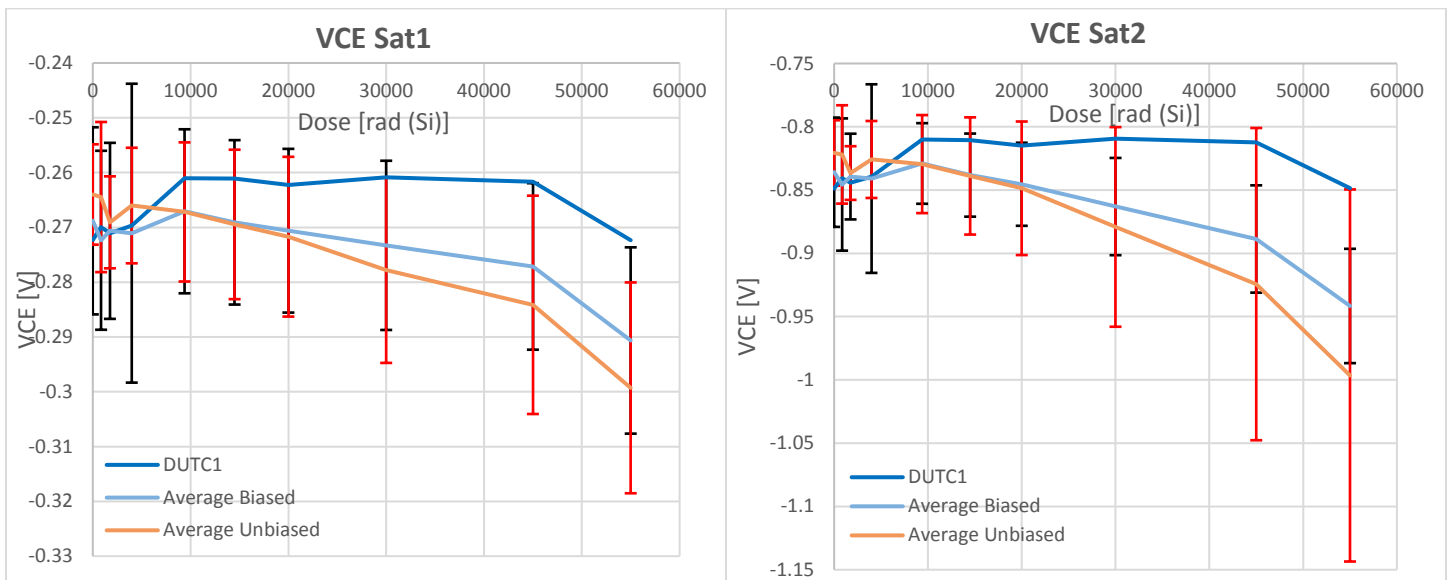

Figure 9: Collector-emitter saturation voltages 1 and 2

While both saturation voltages did experience some drift, they stayed within the limits given in Table 3.

5.2. 2N2222

In Figure 10, Figure 11, and Figure 12, the unbiased BJTs experience more gain degradation than the biased BJTs. This result is consistent with other bipolar devices which experience more degradation when irradiated under unbiased conditions.

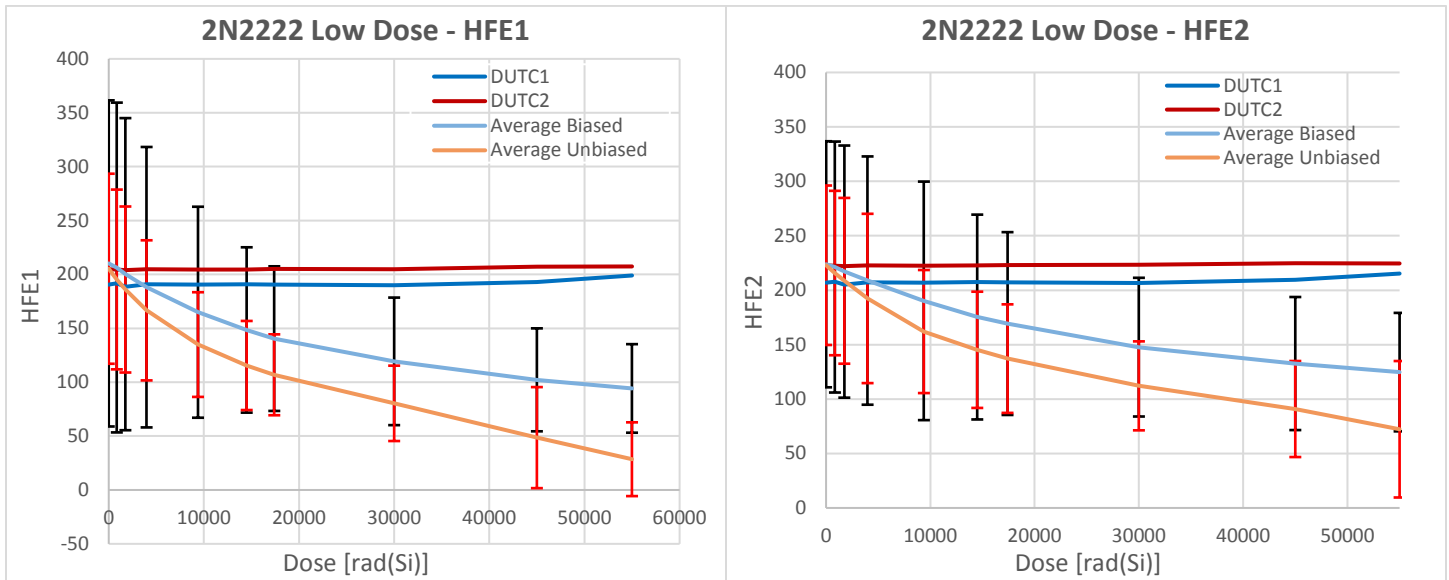

Figure 10: Forward-current transfer ratios 1 and 2

In Figure 10a, two of the unbiased BJTs had an output lower than the minimum limit given in Table 3 after receiving 55 krad of radiation. For the second forward-current transfer ratio, both the biased and unbiased cases stayed within the given range. However, the lower error bar for the unbiased case contains a value below the given minimum.

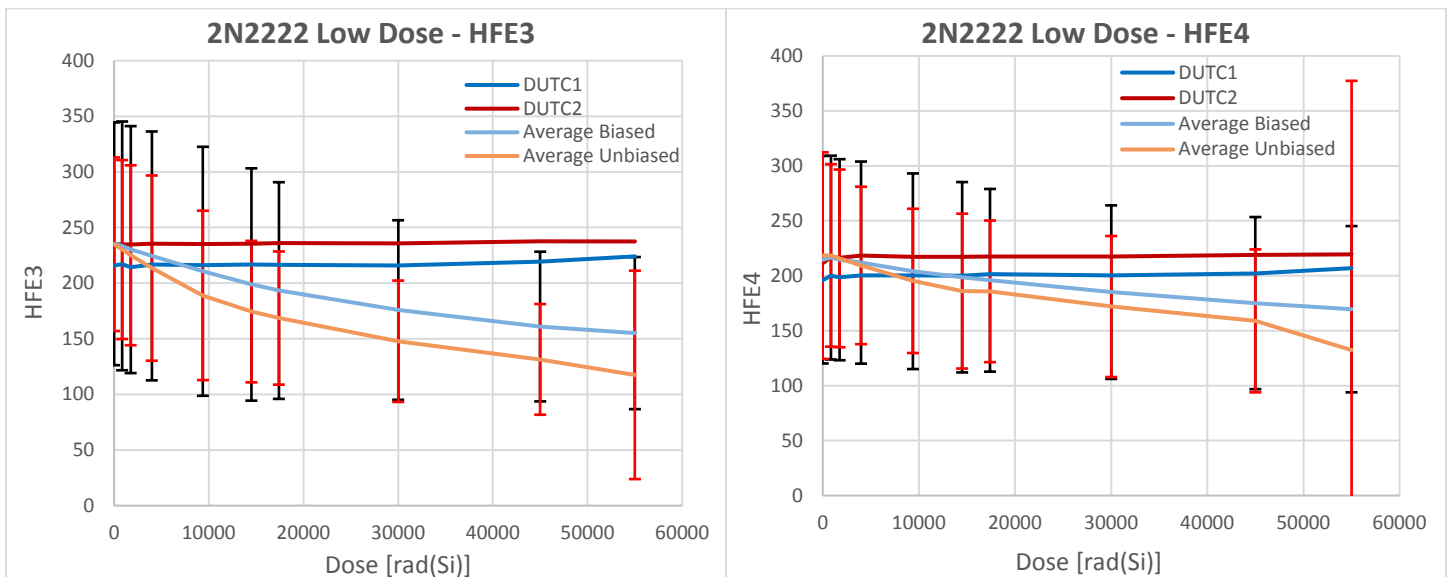

Figure 11: Forward-current transfer ratios 3 and 4

While none of the results in Figure 11a for forward-current transfer ratio 3 were outside of the range in Table 3, a lower error bar for the unbiased case fell outside of that range at 55 krad. Figure 11b contains the result for an unbiased unit that gave an output less than the minimum stated in Table 3. In addition, six upper error bars, four for the biased case and two for the unbiased case, were also above the maximum and one of the lower error bars for the unbiased case was below the minimum.

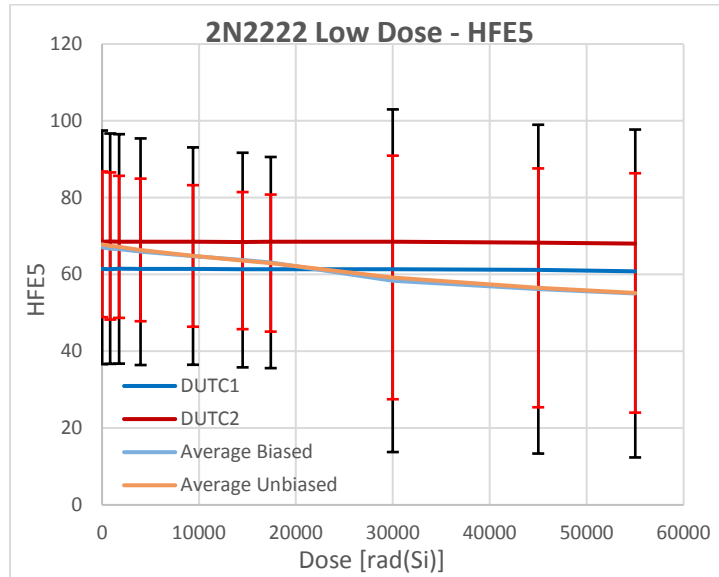

Figure 12: Forward-current transfer ratio 5

While none of the results for forward-current transfer ratio 5 were outside of the ranges given in Table 3, three of the lower error bars for the biased case were below the stated minimum due to the larger variation in results for individual biased units.

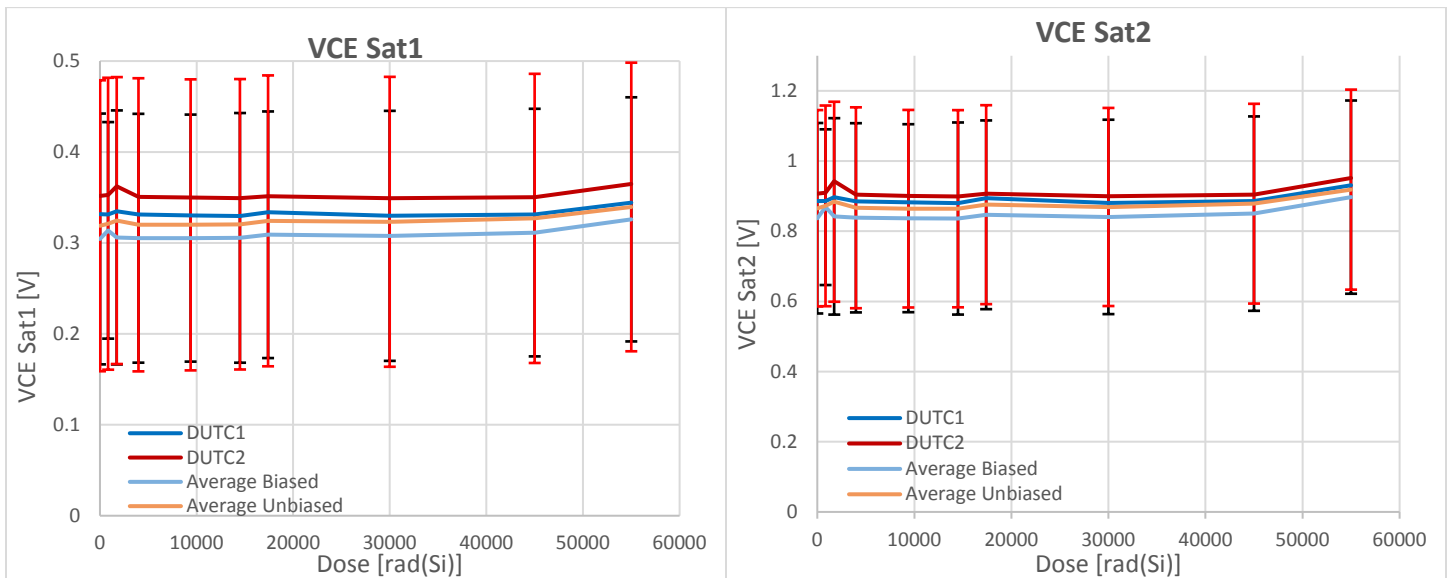

Figure 13: Collector-emitter saturation voltages 1 and 2

One control, one biased, and one unbiased unit in Figure 13aFigure 12 had output voltages above the maximum listed in Table 3. As a result, both the biased and unbiased cases had an upper error bar that gave values more than that maximum. In Figure 13b, none of the results for the second collector-emitter saturation voltages exceeded the maximum given. Almost all of the upper error bars for the unbiased case and one bar for the biased case were above the maximum voltage given. See Figure 12.

6. Conclusion

Both the 2N2907s and the 2N2222s experienced gain degradation. Units that were unbiased during irradiation experienced the most amount of degradation, which is consistent with other bipolar devices.

After 45 krad of radiation, two of the unbiased 2N2907s ceased to output a forward-current transfer ratio. When radiation was increased, the remaining three unbiased units also ceased to give a gain. For both the biased and unbiased cases, the saturation voltage did experience some drift, but stayed within the range given by the device's data sheet.

After 55 krad of radiation, two of the unbiased 2N2222s experienced enough gain degradation so that they no longer were within the range specified by the data sheet. After 45 krad of radiation, the error bars, determined using K_{TL} 99/90 statistics, for four of the forward-current transfer ratios were outside of the limits specified in the data sheet. Furthermore, one control and one unbiased unit had collector-emitter saturation voltages above the maximum listed before any irradiations took place. At 850 rad, a third sample, a biased one, also had a voltage outside of the range given.