

National Aeronautics and
Space Administration

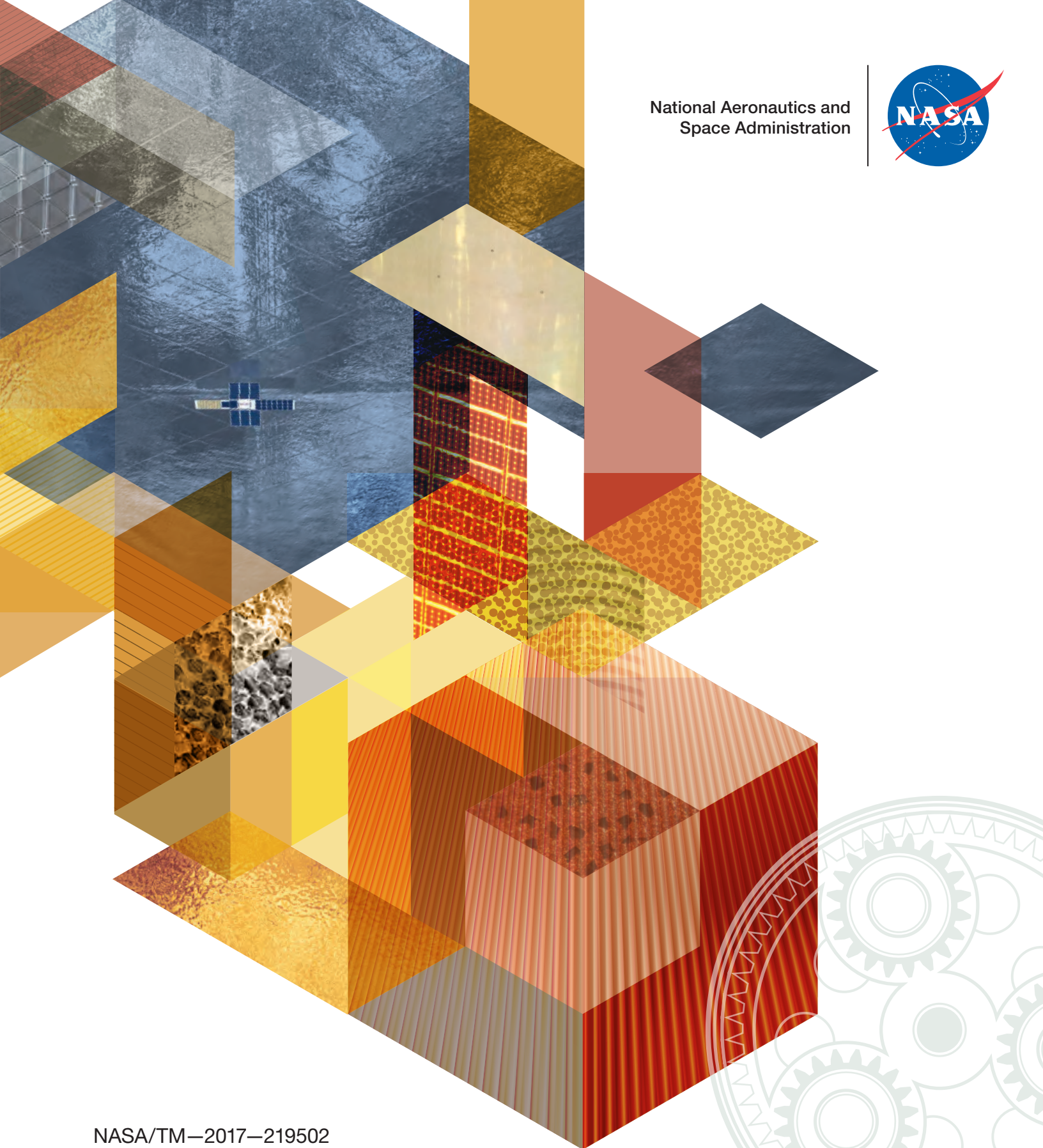
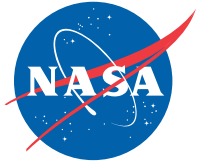

NASA/TM—2017—219502

Marshall Space Flight Center
RESEARCH AND TECHNOLOGY REPORT 2016

Marshall Space Flight Center
Research and Technology Report 2016

*M.L. Tinker, M.B. Abney, D.W. Reynolds, and H.C. Morris, Compilers
Marshall Space Flight Center, Huntsville, Alabama*

ACKNOWLEDGMENTS

The points of contact and coordinator at Marshall Space Flight Center (MSFC) for this Technical Memorandum (TM) are Mike Tinker (256-544-4973) and Heather Morris. The MSFC Office of Center Chief Technologist recognizes Janice Robinson, Terry Frakes, and Kathy Jobczynski of the MSFC Scientific and Technical Information Group for assisting in the development of this report. The Acting Center Chief Technologist Mike Tinker, Technologist Morgan Abney, Technologist David Reynolds, and Technologist Heather Morris provided the support, knowledge, insight, and decisions needed for the compilation of this TM.

TRADEMARKS

Trade names and trademarks are used in this report for identification only. This usage does not constitute an official endorsement, either expressed or implied, by the National Aeronautics and Space Administration.

For additional copies of this report contact:

NASA STI Information Desk
Mail Stop 148
NASA Langley Research Center
Hampton, VA 23681-2199, USA
757-864-9658

This report is available in electronic form at
<<http://www.sti.nasa.gov>>

FOREWORD

Marshall Space Flight Center is essential to human space exploration and our work is a catalyst for ongoing technological development. As we address the challenges facing human deep space exploration, we advance new technologies and applications here on Earth, expand scientific knowledge and discovery, create new economic opportunities, and continue to lead global space exploration.

Our investments in technology not only support NASA's current missions, but also enable new missions and scientific pursuits. Some of these projects will lead to a sustainable in-space architecture for human space exploration, such as developing and testing cutting-edge propulsion solutions for spacecraft and landers for the journey to Mars. Others are working on technologies that could support deep space habitats, which will enable humans to safely live and work in deep space and on the surface of Mars and other destinations across the solar system. Still others are developing new scientific instruments capable of providing an unprecedented glimpse into the early universe.

Our work is driven by the greater purpose of scientific progress and discovery.

While each project in this report seeks to advance new technology and challenge orthodoxies, it is important to recognize the diversity of activities supporting our mission. This report underscores the Center's capabilities and highlights the progress achieved over this past year. These scientists, researchers and innovators are why NASA will continue to be a world leader in innovation, exploration, and discovery for years to come.

I hope you enjoy reviewing this report. It has been an exciting year and has set the stage for even more progress in 2017.

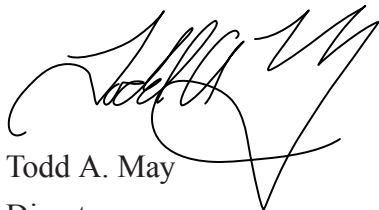

Todd A. May

Director

Marshall Space Flight Center



INTRODUCTION



It is my great honor to present the Marshall Space Flight Center Research and Technology Report for 2016. The talented Center workforce is pursuing a wide variety of research and technology efforts, and this document showcases their incredibly impressive work. From early stage innovations developed in the Center Innovation Fund Program to advanced technologies that were investigated for future flights in the Technology Demonstration Missions Program, the efforts detailed in this report should advance the current state of technology such that future NASA missions are enabled.

Marshall's technologists achieved significant accomplishments in projects funded by the Human Exploration and Operations Mission Directorate (HEOMD) in the Advanced Exploration Systems (AES) Program. The HEOMD work was managed by the Flight Programs and Partnerships Office.

Excellent progress was also achieved in technology projects funded by the Space Technology Mission Directorate (STMD), including efforts in the Technology Demonstration Missions (TDM) Program, Centennial Challenges Program, Game Changing Development, Small Business Innovation Research (SBIR) and Small Business Technology Transfer (STTR), Small Spacecraft Technology Program, and Center Innovation Fund. These efforts were managed by the Science and Technology Office, Flight Programs and Partnerships Office, and Office of the Center Chief Technologist.

Technology efforts at MSFC funded by the Science Mission Directorate (SMD) included work in the Astrophysics Division and the Planetary Science Division. This work was managed by the Science and Technology Office.

Marshall Center Management and Operations (CM&O) funded efforts such as the Technology Investment Program and Dual-Use Technology Cooperative Agreement Notice (CAN). This work was managed by the Office of Strategic Analysis and Communications and the Center Strategic Development Steering Group.

All the outstanding innovations described in this report may serve to not only enhance and enable NASA's near-term programs and projects, but could also provide the solutions required for future Mars missions, human and robotic exploration of other solar system bodies, and destinations beyond. I trust that you will enjoy reviewing the Marshall technology accomplishments of 2016.

A handwritten signature in black ink that reads "Mike Tinker". The signature is fluid and cursive.

Mike Tinker

Center Chief Technologist (Acting)
Marshall Space Flight Center

TABLE OF CONTENTS

| | |
|---|-----------|
| Propulsion Systems | 1 |
| <i>FEATURE</i> : Near Earth Asteroid Scout | 2 |
| Solid and Liquid Rocket Propulsion | 5 |
| New Method Applied to Propellant Slosh and Launch Pad Environments Mitigation .. | 6 |
| Optical Diagnostic Technology for Generating Plume-Induced Environments | 7 |
| Cold Flow Propulsion Test Complex Pulse Testing | 8 |
| Blast Physics Knowledge and Applications | 9 |
| In-Space Propulsion | 11 |
| Integrated Vehicle Fluids | 12 |
| Nuclear Thermal Propulsion | 13 |
| Structural Origami Array | 14 |
| Passive Technology to Improve Criticality Control of Nuclear Thermal Propulsion Reactors | 15 |
| The Iodine Satellite | 16 |
| Innovative Fabrication of Nuclear Fuel Material for Nuclear Thermal Rockets | 17 |
| Nuclear Thermal Rocket and Arc Jet Integrated System Modeling | 18 |
| Pulsed Lorentz Accelerator | 19 |
| Linear Transformer Drivers | 20 |
| Pulsed Plasma Thruster for CubeSats | 21 |
| Small Spacecraft Green Propulsion System Development | 22 |
| Dual Mode Green Propulsion Proof of Concept | 23 |
| Power and Energy Storage | 25 |
| High-Temperature Thermoelectrics | 26 |
| Optimization of Ultracapacitors | 27 |
| Autonomous Systems | 29 |
| Autonomous Mission Operations—Expedite the Processing of Experiments to Space Station-2 | 30 |
| MSFC Autonomous Systems and Operations | 31 |
| Communication and Navigation | 33 |
| <i>FEATURE</i> : Propellantless Attitude Control of Solar Sails Using Reflective Control Devices | 34 |

| | |
|---|-----------|
| Delay and Disruption Tolerant Network | 36 |
| Fast-Light Enhanced Fiber Gyroscope..... | 37 |
| Fast-Light Enhanced Active Gyroscopes, Accelerometers, and Fiber-Optic Sensors.... | 38 |
| Correlated Electromagnetic Levitation Actuator..... | 39 |
| Life Support and Environmental Monitoring | 41 |
| <i>FEATURE</i> : Series-Bosch Oxygen Recovery for Life Support..... | 42 |
| Hydrogen Purification for Life Support..... | 44 |
| Plasma Pyrolysis Technology for Life Support | 45 |
| Upgrades to the ISS Urine Processor Assembly..... | 46 |
| Upgrades to the ISS Water Processor Assembly..... | 47 |
| Life Support Systems | 48 |
| Carbon Dioxide Removal and Management..... | 49 |
| Trace Contaminant and Particulate Matter Control..... | 50 |
| Wireless Temperature Sensing in the Urine Processor Assembly..... | 51 |
| Human Exploration Destination Systems | 53 |
| Additive Construction with Mobile Emplacement..... | 54 |
| Ionic Liquid Metals and Oxygen Extraction in Microgravity — A Prelude to Asteroid Mining..... | 55 |
| Science Instruments | 57 |
| Advanced UVOIR Mirror Technology Development for Very Large Space Telescopes | 58 |
| Mars Ascent Vehicle..... | 59 |
| Low-Noise Cameras for Suborbital Observations | 60 |
| Modeling and Information Technology..... | 61 |
| <i>FEATURE</i> : Streamlining Access to NASA Data to Address Agricultural and Water Availability Issues..... | 62 |
| Cloud-Based App Design | 64 |
| Dengue Forecasting Project..... | 65 |
| Enabling Fast-Responding Pressure-Sensitive Paint Systems in Blow Down Wind Tunnels..... | 66 |
| Immersive Decision Making Environment for Mission-Driven Technology Alignment..... | 67 |
| Topic Mapping | 68 |
| Concept Analysis Using Natural Language Understanding | 69 |

| | |
|---|-----------|
| Manufacturing | 71 |
| <i>FEATURE</i> : In-Space Recycler Technology Demonstration | 72 |
| Manufacturing Advanced Channel Wall Nozzle Rocket Liners..... | 74 |
| Development of the Ultrasonic Stir Weld Process | 75 |
| Self-Reacting Friction Stir Welding on Space Launch System Core Stage..... | 76 |
| Modular Tooling Approach for Manufacturing of Large-Scale Launch Vehicle Structures | 77 |
| Design and Manufacture of Pin Tools for Friction Stir Welding of Temperature-Resistant Materials | 78 |
| Metallic Joining to Advanced Ceramic Composites | 79 |
| Additive Manufacturing | 81 |
| Additive Manufacturing Facility | 82 |
| In-Space Manufacturing Project..... | 83 |
| 3D Printed Augmented Spark Igniter for the RS-25 Engine..... | 84 |
| Achieving Certification of Additive Manufactured Hardware | 85 |
| Design, Development, and Testing of a 3D Printed Rocket Engine Turbopump..... | 86 |
| Empirical Optimization of Additive Manufacturing..... | 87 |
| Loop Heat Pipe Manufacturing for CubeSat Applications | 88 |
| An Additive Manufacturing Technique for the Production of Electronic Circuits..... | 89 |
| Toward In-Space Additive Manufacturing of Thermosets with Embedded Fibers | 90 |
| Bimetallic Additively Manufactured Main Combustion Chambers..... | 91 |
| Space Environmental Effects on Additively Manufactured Parts..... | 92 |
| Selective Laser Ablation and Melting | 93 |
| Embedded Wireless Strain Sensors for Rapid Characterization of Structural Health..... | 94 |
| Materials Development | 95 |
| Diamond-Based Propulsion Materials | 96 |
| Novel Functionally Graded Coating System for Reusable Very High Temperature Applications..... | 97 |
| Thermal Management | 99 |
| A High-Efficiency Cryocooler for In-Space Cryogenic Propellant Storage | 100 |
| Evaluation of Carbon Composite Vessels Fabricated Using Ionic Liquid Epoxies for Cryogenic Liquid Containment..... | 101 |
| Cryogenic Transfer Line Chillover Correlations in Generalized Fluid System Simulation Program..... | 102 |



PROPULSION SYSTEMS

This section includes solid rocket propulsion systems, liquid rocket propulsion systems, air-breathing launch systems, reaction control systems (RCSs), unconventional propulsion systems, in-space propulsion systems, and balloon systems. A primary goal of solid and liquid propulsion systems, as well as air-breathing, RCS and balloon systems, is to make access to space more affordable, reliable, and routine. In-space propulsion

technology development focuses on increasing thrust, specific impulse, volume, manufacturability, safety, reliability, and cost. MSFC has historically established itself as one of the primary places where propulsion systems are developed and tested, and that history continues today with propulsion development efforts spanning solid, liquid, RCSs, in-space propulsion, and advanced propulsion concepts.

Near Earth Asteroid Scout

OBJECTIVE: *NEA Scout will use a solar sail to propel a small spacecraft on a two-and-a-half year mission to explore an asteroid.*

PROJECT DESCRIPTION

NASA plans to explore Near Earth Asteroids (NEAs) in the next decade as part of a long-range plan that will culminate in human exploration of Mars. Before committing a crew to visit an NEA or Martian moon, it is important that we carry out precursor robotic missions to assess candidate objects adequately enough that we can develop crew systems appropriate for target environments. The NEA Scout, scheduled to launch in 2018, will use its solar sail propulsion system to send a small spacecraft to fly by asteroid 1991VG and conduct reconnaissance of it. Solar sails ‘sail’ by reflecting sunlight from a large, lightweight reflective material that resembles the sails of 17th and 18th century ships and modern sloops. Instead of wind, the sail and the ship reflect solar photons to derive their thrust. While the force sunlight exerts is extremely small, it is relatively constant, resulting in a slow but constant acceleration that pushes the sail—and the spacecraft attached to it—to higher and higher speeds, and it does so without using any fuel. NEA Scout is being developed at Marshall Space Flight Center (MSFC), Jet Propulsion Laboratory (JPL) and Langley Research Center (LaRC). The 86-m² solar sail propulsion system is being developed and tested at MSFC.

The NEA Scout spacecraft is housed in a 6U-CubeSat form factor. (A CubeSat is a very small spacecraft built on a modular design architecture of 10 cm × 10 cm × 10 cm cubes. Each cube is called a “U” and is typically allocated about two pounds of total mass. We can then combine these cubes together to build a spacecraft.) The solar sail will be a single sail deployed on four 6.8 m booms from the center 2U of the 6U spacecraft. The solar sail subsystem consists of a single 86-m² colorless polymer (CPI), and a 2.5-micron-thick aluminized sail that will sit on top of, and be deployed by, four Elgiloy (a stainless steel alloy) booms. The boom deployers consist of two boom spools, each containing two booms. The second figure shows the stowed sail and booms. The single-sail design provides full shade for the booms, eliminating the thermal deflection as a concern.

The NEA Scout’s reaction control system (RCS) consists of a set of reaction wheels and uses a slow roll about the solar sail’s normal axis to handle attitude control and adjust for imperfections in the deployed sail during the mission. Due to a significant anticipated offset in center-of-mass and center-of-pressure, we added an Active Mass Translator to the design, residing near the geometric center of the spacecraft.

ACCOMPLISHMENTS

NEA Scout project successfully completed its design review in August 2016. Also completed were the solar sail, deployer, and active mass translation table Engineering Development Units, as well as test sail deployments. We refined the sail thrust model, and significantly refined the overall sail trajectory analysis.

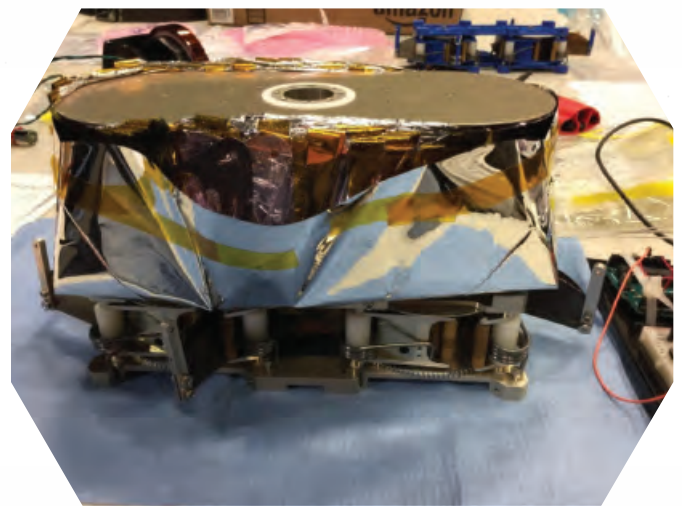

The complete solar sail and booms are packed and stowed into a 2U module within the NEA Scout spacecraft. Seen here is the packaged sail system before deployment.

feature

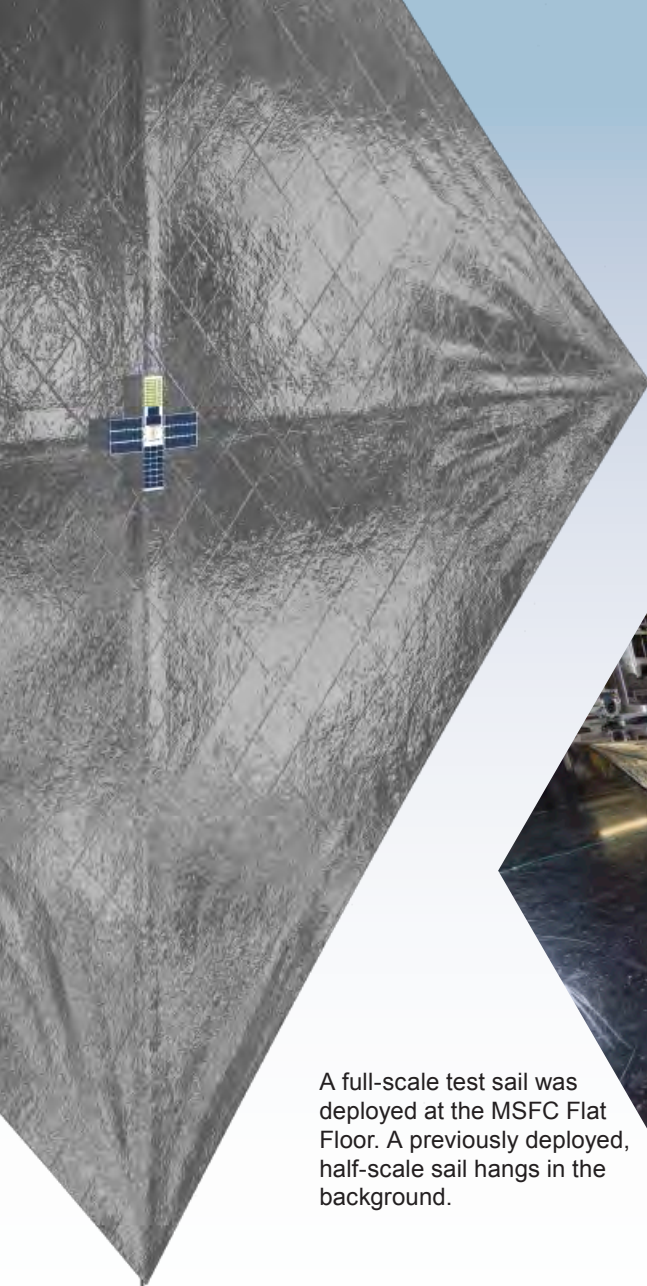

A full-scale test sail was deployed at the MSFC Flat Floor. A previously deployed, half-scale sail hangs in the background.

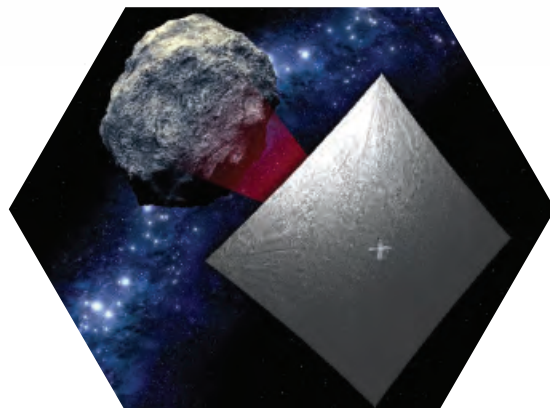
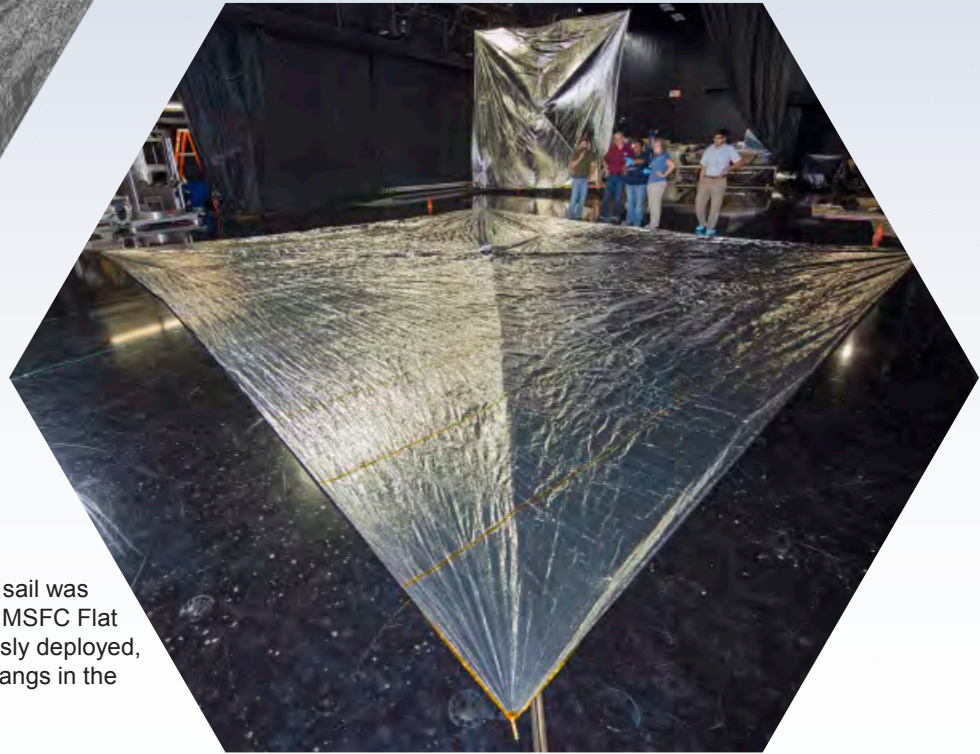

Artist's concept of the NEA Scout spacecraft and solar sail during its planned rendezvous with Asteroid 1991VG.

BENEFITS

NEA Scout permits a novel way to explore NEA, and the Moon, as the last figure shows, and paves the way for future low-cost planetary science and exploration. Because it requires no propellant, using only sunlight to provide its propulsive thrust, solar sails like the one being developed for NEA Scout will foster a host of deep space missions which cannot be accomplished with more traditional propulsion systems.

PROJECT MANAGER: Leslie McNutt

PRINCIPAL INVESTIGATOR: Les Johnson

FUNDING ORGANIZATION: Advanced Exploration Systems

FOR MORE INFORMATION: <https://techport.nasa.gov/view/14656>

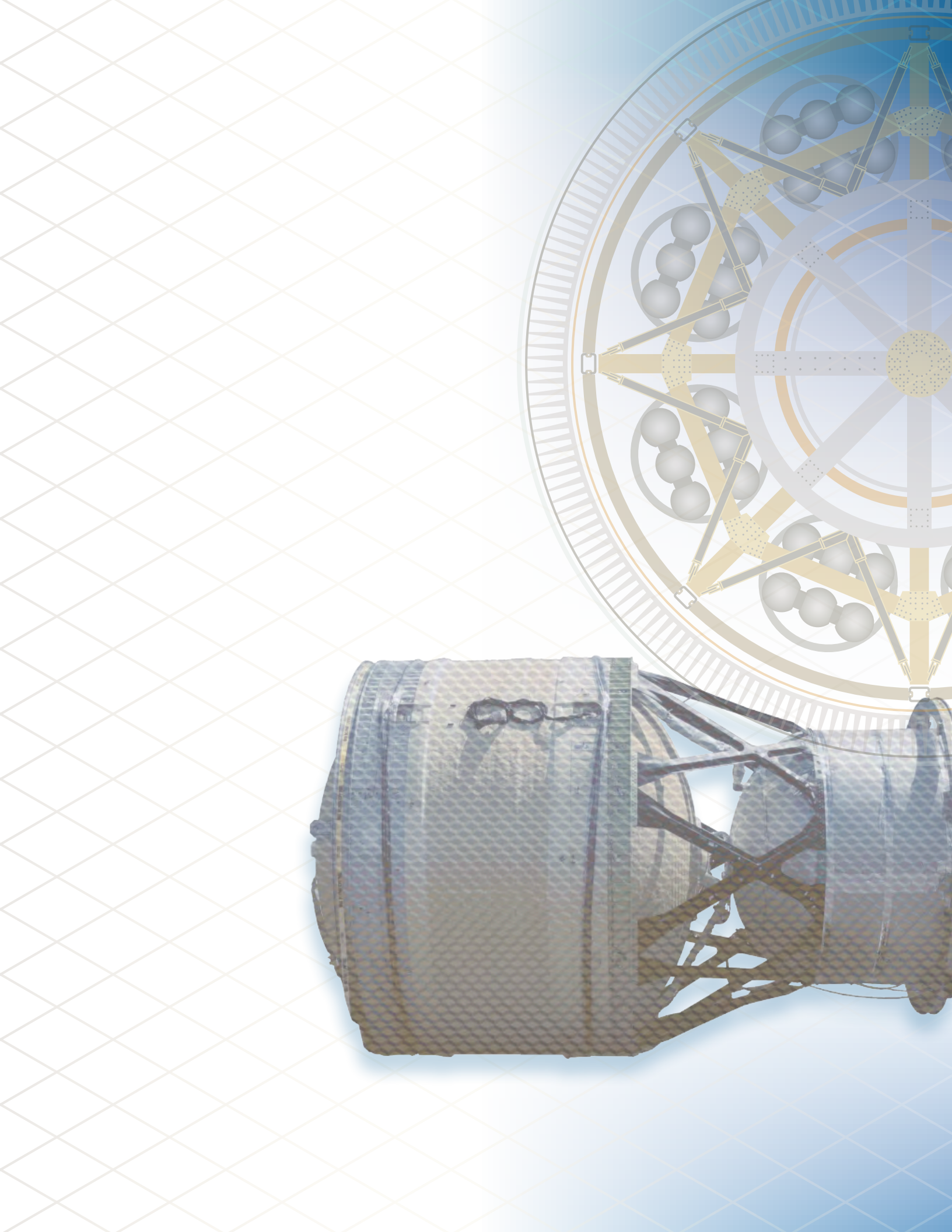



PROPULSION SYSTEMS

Solid and Liquid Rocket Propulsion

Chemical, solid, and liquid rocket propulsion systems have been used since the dawn of spaceflight, and as their names suggest, consist of fuel and oxidizers in solid or liquid form. These technologies are reaching the limits of theoretical efficiency and performance using conventional propellants.

Key areas for improvement include developing a green (environmentally compatible, non-toxic, and non-carcinogenic) propellant alternative to current oxidizers, advancing the ability to assess damage tolerance limits and detect

damage on composite cases, developing domestic sources for critical materials used in manufacturing of solid rocket motors (SRMs), formulating advanced hybrid fuels to get energy density equal to SRMs, and advancing the fundamental physics of SRM design including analysis and design tools.

Liquid rocket propulsion systems use propellants (fuels and oxidizers) that are kept in a liquid state prior to and during flight. The advantages of liquid rocket engines include generally higher specific impulse and better thrust control (including throttling

and restart capability) than SRMs. Some disadvantages of liquid rocket propulsion systems are that they are more operationally complex than solids, and require some form of active flow control that introduces additional possibilities for failures. For Earth-to-orbit applications, the primary delivery system for the propellants to the thrust chamber is via turbo machinery that raises the propellant pressures sufficiently to support the high-pressure combustion process.



New Method Applied to Propellant Slosh and Launch Pad Environments Mitigation

OBJECTIVE: *Use computer modeling to enhance launch vehicle design.*

PROJECT DESCRIPTION

In order to understand, design, build, and improve rockets, NASA uses computational fluid dynamics (CFD) software programs. These programs model the behavior of liquids and gases within a system extensively and provide designers with detailed insight. Marshall Space Flight Center (MSFC) implemented a CFD method—the volume of fluid (VoF) method—to expand general purpose CFD programs greatly, which will better simulate launch and in-space applications. Applications involving complex fluid dynamics can contribute strongly to propulsion and integrated vehicle system performance, life, and stability.



VoF method CFD simulation of propellant slosh within a propellant tank with ring baffles.

ACCOMPLISHMENTS

We use circumferential baffle rings to dampen propellant slosh, or movement, inside propellant tanks. We have found that propellant tank slosh damping predictions using traditional models are inaccurate and inadequate for the Space Launch System (SLS) design. In FY2016, MSFC analyzed complex fluid dynamics inside SLS tanks using CFD tools that incorporate the VoF method to quantify propellant slosh damping. The predicted damping values were critical inputs into an integrated model used to analyze SLS vehicle stability.

Also in FY2016, initial assessments of the system that sprays water below SLS to protect SLS during launch found that the multiple streams of water formed geysers. These geysers wetted critical portions of the SLS launch vehicle and prohibited critical systems' function on the launch pad. Investigating the causes of the geysers using the VoF method led to the redesign of the launch water spray system.

BENEFITS

This technology facilitates accurate predictions of how rocket propulsion-specific systems that involve interaction between liquids and gases perform. Two examples are described above, but many other applications of the VoF method have yet to be addressed, e.g., simulation of liquid propellant mixing within the combustion chambers of liquid rocket engines, propellant flow suppression devices that control back and forth flow oscillations, and flow dynamics of solid rocket motor exhaust. These past and future examples show the value, and expected increased use, of this design-by-analysis approach and its potential to decrease both cost and schedule of rocket propulsion systems design.

PROGRAM MANAGER: Jeff West

FUNDING ORGANIZATION: Human Exploration and Operations Mission Directorate

Optical Diagnostic Technology for Generating Plume-Induced Environments

OBJECTIVE: Visualize rocket plume-induced base flow fields using non-intrusive optical diagnostics.

PROJECT DESCRIPTION

This project’s scope was to determine the feasibility of various novel non-intrusive optical diagnostics to capture launch vehicle rocket plume-induced base flow physics in a ground test facility. Three optical diagnostics were proposed to visualize base and rocket

plume flows at various simulated altitudes. They are hydroxyl radical — planar laser induced fluorescence (OH-PLIF) imaging, carbon-dioxide seeded infrared (IR) imaging, and tunable diode laser absorption spectroscopy (TDLAS). They were developed and tested in collaboration with NASA Marshall Space Flight Center, NASA Langley Research Center, and CUBRC Inc. NASA proposed using a nine million-pound thrust launch vehicle with multiple rocket engines and solid rocket motors for humans to explore deep space, which results in considerably higher base heating rates and drag than current launch vehicles. We must understand flow physics for efficient and safe designs of the thermal protection system.

ACCOMPLISHMENTS

We did not attempt PLIF and IR imaging to observe plume-induced base flow environments prior to the FY2016 Technology Innovation Program (TIP). Regular visible cameras cannot capture the flow features, leaving the vehicle design flying blind. Through the FY2016 TIP, we used non-intrusive optical diagnostics for the first time to visualize how reacting turbulent flows in a multi-engine launch vehicle base behave. OH-PLIF imaging, IR imaging, and TDLAS successfully captured the turbulent reacting base flows, rocket plumes, and base gas temperatures, respectively, during simulated launch vehicle ascent.

BENEFITS

Inadequately characterizing launch vehicle plume-induced base flow environments can lead to mission failure. Visualizing the flow physics is critical to capture “hot spots” and must be done with both surface measurements and imaging. Imaging provides a high-resolution view of the base flow field and the trajectory of hot gases not captured by discrete intrusive measurements. FY2016 TIP optical diagnostic data also provide technical confidence in ground test technology, improves scaling methods, and aids in these complex flows’ computational model validation. The ground test and optical diagnostic technologies developed can characterize many rocket plume-induced environments fully; we need all of them for the design of both science and crew vehicles to Mars.

PROJECT MANAGER: Dr. Manish Mehta, Aerosciences Branch

FUNDING ORGANIZATION: Technology Investment Program

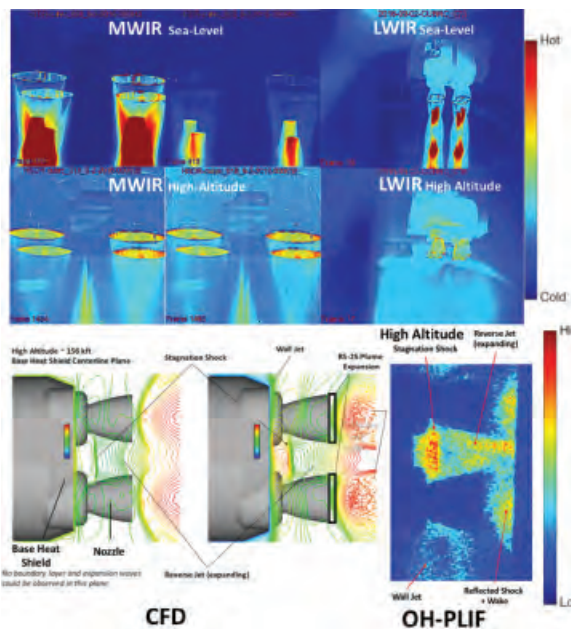

Near-field and far-field IR imaging captured rocket plume flow structures and plume-plume interactions (top). OH-PLIF imaging captured launch vehicle turbulent reacting base flow features and is compared to computational solutions (bottom).

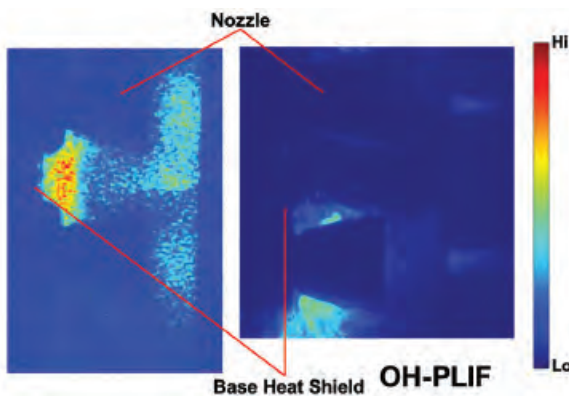

OH-PLIF imaging comparison at base heat shield centerline between high-altitude (left) and sea level (right) conditions.

Cold Flow Propulsion Test Complex Pulse Testing

OBJECTIVE: *Use testing to validate the suppressors on the Space Launch System main engine.*

PROJECT DESCRIPTION

When the propellants in a liquid rocket engine burn, the rocket not only launches and moves in space, but it also causes forces that interact with the vehicle itself. When these interactions occur under specific conditions, the vehicle's structures and components can become unstable. One instability of primary concern is termed pogo (named after the movement of a pogo stick), in which the oscillations (cycling movements) cause large loads, or pressure, against the vehicle, tanks, feedlines, and engine. Marshall Space Flight Center (MSFC) has developed a unique test technology to understand and quantify the complex fluid movements and forces in a liquid rocket engine that contribute strongly to both engine and integrated vehicle performance and stability. This new test technology was established in the MSFC Cold Flow Propulsion Test Complex to allow injection and measurement of scaled propellant flows, and measurement of the resulting forces at multiple locations throughout the engine.

ACCOMPLISHMENTS

The Space Launch System (SLS) main engine—RS-25—was designed with a pogo suppressor to prevent oscillating forces from being transmitted through the engine and impacting its thrust negatively. In FY2016, we tested the RS-25 pogo suppressor at the MSFC Cold Flow Propulsion Test Complex using the piston type pulser, shown in the image above, to quantify the suppressor performance experimentally. The test validated the RS-25 pogo suppressor model used to demonstrate SLS vehicle stability successfully.

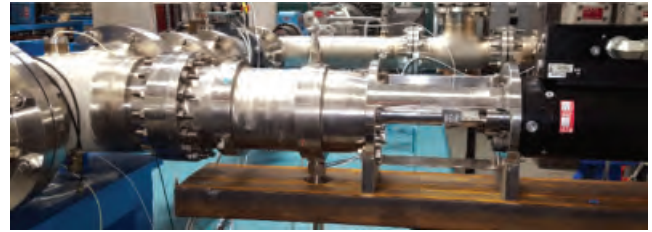

Pulser installed at the MSFC Cold Flow Propulsion Test Complex Pump Test Equipment loop.

BENEFIT

Fluid dynamic environments are highly complex and have strong impacts on rocket engine components, as well as on integrated vehicle stability, life, and performance. By providing a test environment that more accurately represents the real conditions experienced in flight, this new ground test technology helps NASA experts gain a better understanding of the complex forces involved with propellants as they move throughout the engine. These testing data help validate analyses and models ranging from those of basic hardware to complex system interactions.

PROJECT MANAGER: Kris McDougal

FUNDING ORGANIZATION: Human Exploration and Operations Mission Directorate

Blast Physics Knowledge and Applications

OBJECTIVE: *Mature the understanding of exactly what fragments a launch vehicle explosion event produces.*

PROJECT DESCRIPTION

The blast fragments produced by a launch vehicle explosion represent the most serious risk to the crew. The opportunity to study the debris from real accidents to understand the fragments produced—such as number, size, and landing location—can lead to better ways to protect future crews. The Blast Environments team, comprised of Marshall Space Flight Center and Bangham Engineering, Inc., staff has continued to mature NASA’s knowledge of launch vehicle explosions with several successes in FY2016. Blast, or explosion, events are being characterized with sufficient fidelity to allow future vehicle designs to benefit from the knowledge gained. Also, by producing shadowgraphs (see image) of the blast waves coming from a blast event as they interact with various structures, the team has introduced visualization techniques at a larger scale than ever before attempted.

The Blast team has also improved predictions of the characteristics of the fragments being produced by these explosions significantly. The team produced the highest-fidelity fragment distribution model ever created from a real rocket accident by gathering debris from a recent launch vehicle accident and weighing, measuring, and combining information on the fragments with available geolocation data.

ACCOMPLISHMENTS

Shadowgraphs are allowing the Blast team to visualize individual explosion compression waves and understand how they coalesced into larger blast waves. This same technique will be used to visualize how the blast waves interact with structures like propellant tanks to understand how the blast waves lead to the destruction of the vehicles. These techniques will further advance our knowledge of these dangerous events, which could lead to even safer vehicles in the future.

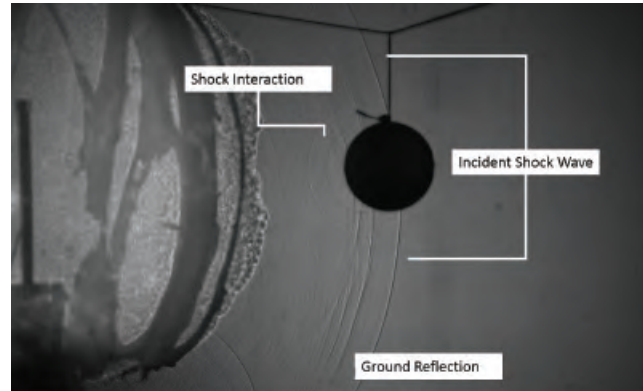

High-speed shadowgraphs are used to visualize blast waves.

The detailed study of blasts is improving blast models and the predictions of the risk to the crew greatly. Eventually, they will be used for improved safety systems design to further reduce the risks.

BENEFITS

NASA is working to reduce the risk to future astronauts by developing the fundamental knowledge of launch vehicle explosions. Similar to the automotive industry where studies of accidents and crash tests have led to dramatically improved passenger safety, here NASA is developing the engineering and scientific data to design safer launch systems. The technology is expected to reduce the risk to future astronauts.

PROGRAM MANAGER: Mike Bangham

FUNDING ORGANIZATION: Human Exploration and Operations Mission Directorate



PROPULSION SYSTEMS

In-Space Propulsion



The overall goals for developing in-space propulsion technologies are to create improvements in thrust levels, specific impulse, power, specific mass (or specific power), volume, system mass, system complexity, operational complexity, commonality with other spacecraft systems, manufacturability, durability, safety, reliability, and cost. The in-space propulsion

needs of any given mission (or mission class) are highly dependent upon the mission architecture, and there is no “one-size-fits-all” technology solution that will work for all missions or even all mission classes. The development of higher power electric propulsion, nuclear thermal propulsion, and cryogenic chemical propulsion will have the broadest overall impact on enabling or enhancing missions across each class.¹

¹ NASA Technology Roadmaps, TA 2: In-Space Propulsion Technologies, p. TA 2 –4, July 2015. <https://www.nasa.gov/offices/oct/home/roadmaps/index.html>

Integrated Vehicle Fluids

OBJECTIVE: *Evaluate the ULA Integrated Vehicle Fluid (IVF) system for its viability for use in the Space Launch System Exploration Upper Stage (SLS EUS).*

PROJECT DESCRIPTION

The evolvable Cryogenic (eCryo) Project is a Space Technology Mission Directorate technology development project that will mature cryogenic fluid management (CFM) technologies that support future exploration propulsion needs and upgraded versions of the Space Launch System (SLS). The eCryo project is a multi-Center effort that features NASA Glenn Research Center (GRC) and NASA Marshall Space Flight Center (MSFC). eCryo was tasked to test the United Launch Alliance (ULA) patented integrated vehicle fluids (IVF) system (generation 1.5) and assess the technology benefits for the SLS Exploration Upper Stage (EUS). The IVF system has three primary functions: pressurization, reaction control, and electrical power generation. The IVF system's many potential benefits include mass savings, elimination of hydrazine on the stage, and Auxiliary Power Unit (APU)-like electrical power generation that extends electrical power availability.



The blower and the heat exchanger loop are pictured above for the IVF "Phase B" testing.

ACCOMPLISHMENTS

The eCryo project is evaluating this technology by building and testing a simulated IVF system with an electric commercial off-the-shelf (COTS) blower. The blower performed successfully, demonstrating that an IVF-like system can pressurize a cryogenic tank.

Another significant accomplishment was the conception, design, and development of simulated injectors that allowed us to mix the ullage gas. Mixing the gas provided a source of cold (colder) gas to feed the blower/compressor. The injectors were modeled with computational fluid dynamics software. The next step is to test the actual ULA hardware and collect the data for modeling. The system is being modeled using a Generalized Fluid System Simulation Program (GFSSP) for heat transfer and energy balance. Once test data anchor the GFSSP models, we will model the EUS IVF system in GFSSP.

BENEFITS

We are assessing several potential benefits of the IVF system for the SLS EUS. They include an increase in payload mass, eliminating hydrazine from the upper stage to improve personnel safety, and increased electrical power availability over the current battery designs. The residual vapor in the tank can continue to generate IVF electrical power once main engine burns are complete. The increased stage life will allow more flexible missions and mission scenarios. This collaboration also benefits ULA and enhances their own vehicle's Automated Construction of Expeditionary Structures (ACES) stage capabilities. This emerging technology provides a novel method of operating an upper stage with the potential for significant advancement in the field of rocketry. Further component development, testing, and system maturation is needed before we can consider flight designs for infusion into the SLS EUS. We must also determine the cost of incorporating a flight IVF system into the SLS EUS. If successful, applying this technology will benefit the SLS program and U.S. launch provider ULA by increasing launch vehicle capabilities.

PROJECT MANAGER: Hans Hansen

FUNDING ORGANIZATION: Technology Demonstration Missions

Nuclear Thermal Propulsion

OBJECTIVE: *Develop a low-enriched uranium (LEU) Nuclear Thermal Propulsion system, the most promising advanced in-space propulsion option for crewed missions, and determine feasibility and affordability with good cost and schedule confidence.*

PROJECT DESCRIPTION

NASA's history with nuclear thermal propulsion (NTP) technology goes back to the earliest days of the Agency, beginning in 1958. Since then, NTP-based vehicle design has been recognized consistently as an important and viable option for exploration of Mars and beyond. The current NTP project objective is to determine LEU NTP feasibility and affordability with good cost and schedule confidence. Using LEU offers potential advantages for a nuclear propulsion program that may include less burdensome security regulations, similar to those for a university research reactor. This opens the development effort to partnerships with industry and academia. Currently, the project is focused on developing technologies that make possible the affordable use of isotopically pure tungsten for fabrication of LEU ceramic metallic (Cermet) fuel elements and establishing the optimal LEU engine architecture (thrust level, physical size, number of engines, etc.) based on requirements for a Mars mission. NTP is a safe, affordable "game changing" technology for space propulsion that enables faster trip times and safeguards astronaut health.

ACCOMPLISHMENTS

The project has demonstrated the technology's technical merit and, subsequently, has started process optimization. The optimization demonstrated purified tungsten, completed initial LEU Engine Architecture Analysis with engine thrust recommendation, determined the framework to evaluate the cost of an LEU NTP system, and worked analysis of the feasibility of total exhaust capture system for testing at a conventional propulsion test facility such as Stennis Space Center.

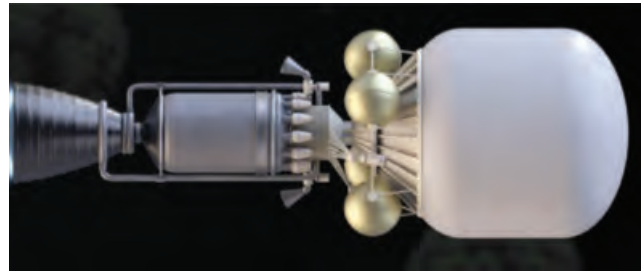

NTP engine and run tank.



Representative NTP stage.

BENEFITS

NTP is directly relevant to the Agency's vision, mission, and long-term goal of expanding human presence into the solar system and to the surface of Mars. As missions aim for targets farther out into the solar system, nuclear propulsion may offer the only viable technological option to extend the reach of exploration where solar panels can no longer provide sufficient energy, and chemical propulsion would require a prohibitively high mass of propellant and/or prohibitively long trip times. NTP provides the fastest trip time of all currently obtainable advanced propulsion systems. Fast trip times will safeguard astronaut health by reducing exposure to zero gravity and cosmic radiation. Reduced travel time also reduces risks associated with reliability uncertainties inherent in complex systems, as well as those associated with life-limited, mission critical systems.

PROJECT MANAGER: Sonny Mitchell

PRINCIPAL INVESTIGATOR: Dr. Michael G. Houts

FUNDING ORGANIZATION: Game Changing Development Program

Structural Origami Array

OBJECTIVE: *Reconfigure solar arrays to significantly increase power generation on small spacecraft.*

PROJECT DESCRIPTION

The Structural Origami ARray (SOAR) is a high-performance deployable solar array system for small spacecraft, such as CubeSats. Small spacecraft are power starved; they are extremely limited in the amount of electricity they can produce while in space. This power starvation restricts their capabilities and limits their payload potential. Traditional solar array systems could be made larger to produce more power; however, they are bulky and quickly use up the limited volume, mass, and surface area of a small spacecraft—again limiting the payload potential. The SOAR uses a two-dimensional packaging scheme of a flexible substrate coupled with a simple deployable supporting structure. This creates large deployed areas of high-efficiency solar cells which can stow compactly into a thin, square form factor. This square readily stows on the limited external surface area of a small spacecraft. The array delivers twice the power output of current systems while minimizing use of spacecraft volume, mass, and surface area. The SOAR will let the next generation of high-power small satellites continue to advance science and engineering.

ACCOMPLISHMENTS

At the beginning of 2016, the SOAR concept had proved critical functions and proof-of-concepts analytically and experimentally. Throughout this year, LoadPath has made steady progress in using laboratory tests to validate the components and/or breadboard configurations for the arrays. LoadPath has created and modeled a conceptual 100-W array design, and has fabricated several low-fidelity prototypes to test

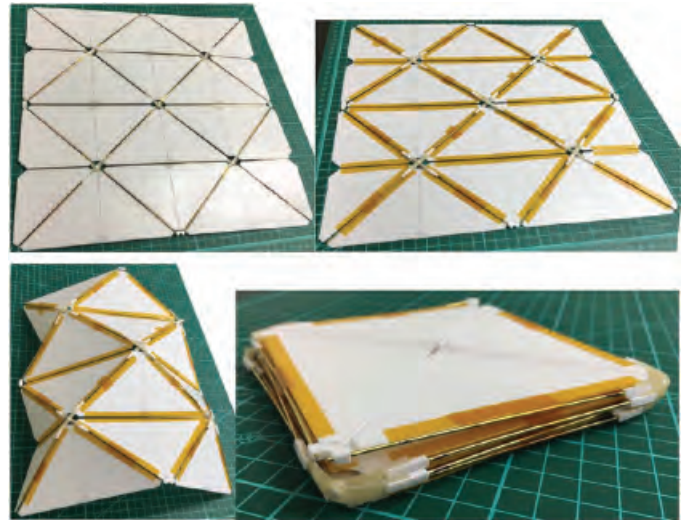

~100-W solar array prototype with deployment lattice: deployed (top) and stowed (bottom).

deployment options. We have defined baseline operating environments, and mass and thickness modeling is currently underway. We expect a fully deployable, medium-fidelity test prototype by the end of the year.

BENEFITS

Small spacecraft are a very advantageous option for spaceflight, since their reduced size and complexity equates to a less costly design and fabrication process. Perhaps more importantly, lighter launch loads generate significant savings in launch costs. This opens a door to space for commercial companies, universities, and governments alike, allowing more to be done with less. SOAR seeks to significantly increase power generation on small spacecraft while using only minimal mass and volume allocation.

PROJECT MANAGERS: Joe Footdale, LoadPath

FUNDING ORGANIZATION: Small Business Innovative Research

FOR MORE INFORMATION: www.loadpath.com

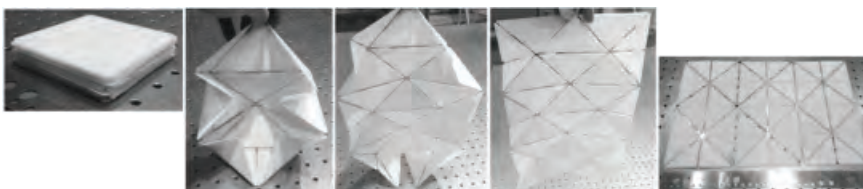

Array fold pattern concept yields perfect packaging with no thickness build-up effects.

Passive Technology to Improve Criticality Control of Nuclear Thermal Propulsion Reactors

OBJECTIVE: *Develop passive nuclear reactor criticality control for nuclear thermal propulsion, which reduces control drum movement to compensate for fission product neutron poison.*

PROJECT DESCRIPTION

NASA is considering the nuclear thermal propulsion (NTP) system for human missions to Mars because the engine performance provides the fastest trip times, which might reduce the number of Space Launch System missions required. The NTP system uses a fission reactor to provide extreme heat to the propellant for thermal expansion through the nozzle. Reactor criticality happens when the amount of neutrons produced from the fission reaction can maintain a self-sustaining fission chain reaction in the core. There are side effects from the fission products formed. One is a neutron poison Xenon-135, which absorbs neutrons. To compensate for neutron poison, we rotated the reactor control drums further to reflect more neutrons back into the core.

A phase II SBIR awarded in mid-FY2016 investigates a passive criticality control technology to simplify the control of NTP systems and increase their overall performance during operation. The technology works by:

- Employing advanced burnable neutron poison to completely remove the need for control drum movement during a full power burn.
- Tuning the hydrogen density to ensure a consistent control drum startup position.
- Enhancing the reactor core temperature reactivity feedback mechanism to ensure reactor stability and reduce the burden for active control.

ACCOMPLISHMENTS

The phase II project has just started, but there are plans in place. One is to produce an NTP transient code capable of modeling NTP systems through startup, steady state, and shutdown. We also plan to use the model to develop the passive criticality control technology, and

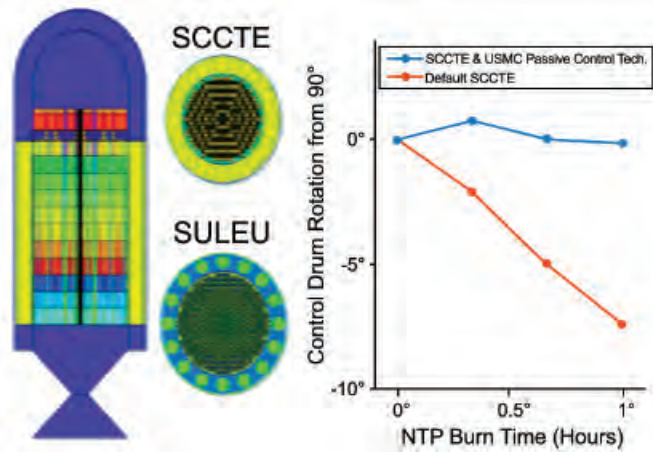

Calculated reduction on NTP control drum rotation for the Space Capable Cryogenic Thermal Engine (SCCTE) concept with passive criticality control.

to design, fabricate, and test in a prototypic environment the passive criticality control alloy. Finally, we plan to deliver NTP system designs that showcase the new technology. Support contracts and agreements are in place to proceed.

BENEFITS

A passive critical control of a nuclear engine has the potential to reduce the control drum rotation greatly, which adds significant margin to reactor control. The transient model being developed for passive criticality control has many other NTP design and development applications.

PROJECT MANAGER: Paolo Venneri, Ultra Safe Nuclear Corporation

FUNDING ORGANIZATION: Small Business Innovative Research

The Iodine Satellite

OBJECTIVE: *Flight demonstration of iodine propulsion technology for small spacecraft.*

PROJECT DESCRIPTION

This effort is a partnership between NASA and the Air Force to mature an iodine Hall Effect Thruster system and perform flight validation of the iodine propulsion system. NASA Marshall Space Flight Center is responsible for project management, the spacecraft bus design and fabrication, and the mission operations. NASA Glenn Research Center is responsible for maturing the propulsion system, with Busek Co. providing the flight hardware.

The Iodine Satellite (iSat) propulsion system consists of the 200-W Hall thruster, cathode, solid iodine propellant tank, a Power Processing Unit (PPU), and the necessary valves and tubing to route the iodine vapor. The bus is a 12U spacecraft chassis constructed from aluminum, with a finish that prevents iodine-driven corrosion. The iSat spacecraft includes full 3-axis control using wheels, magnetic torque rods, inertial management unit (IMU), and a suite of sensors and optics. The spacecraft will leverage heat that the spacecraft's components and radiators generate for a passive thermal control system while demonstrating a power density that is an order of magnitude higher than state of the art.

ACCOMPLISHMENTS

During FY2016, the iSat project completed the project preliminary design review (PDR) successfully. Though many products are complete, the project critical design review (CDR) scheduled for the end of FY2016 has been postponed due to a test anomaly during integration propulsion system testing.

BENEFITS

Propulsion technology is often a critical enabling technology for space missions. NASA is investing in technologies to make possible high-value missions with very small and low-cost spacecraft, even CubeSats. However, these small spacecraft currently lack any appreciable propulsion capability. CubeSats

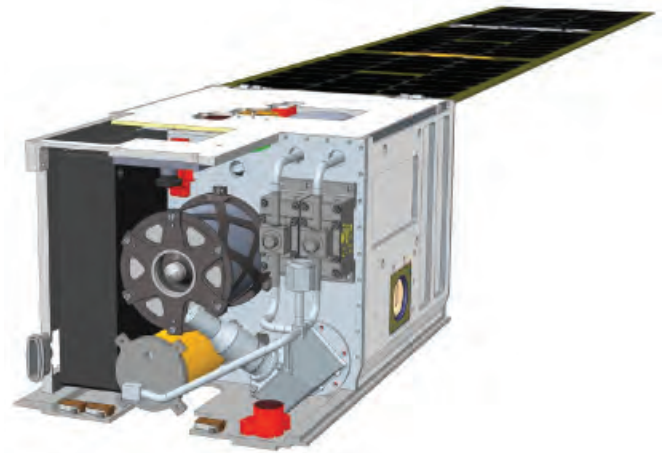

The iSat spacecraft design heading into CDR.

are typically deployed and drift without any ability to transfer to higher value orbits, perform orbit maintenance, or de-orbit. The iodine Hall system, however, can provide a means for the spacecraft to transfer into a higher value science orbit. iSat will be able to achieve a change in velocity of greater than 500 m/s with less than 1 kg of solid iodine propellant, which can be stored in an unpressurized benign state prior to launch.

The benefits of the iodine Hall technology and iSat demonstration include facilitating significant small spacecraft maneuverability with a propulsion system viable with secondary payload launch opportunities. Most of the technology benefits are derived from the unpressurized storage, low pressure operation, and high density. The storage and operating pressures allow for additive manufacture of the propellant tank and shapes to maximum volume. Also, the iodine density components with the Hall thrusters result in more than an order of magnitude improvement in change in velocity per unit volume compared to the current results seen using other small satellites.

PROJECT MANAGERS: John Dankanich; Tim Smith, Goddard Research Center; Larry Byrne, Busek

PRINCIPAL INVESTIGATOR: Hani Kamhawi, Goddard Research Center

FUNDING ORGANIZATIONS: Space Technology Mission Directorate, Small Spacecraft Technology Program

Innovative Fabrication of Nuclear Fuel Material for Nuclear Thermal Rockets

OBJECTIVE: *Investigate an innovative method to produce nuclear fuel material for nuclear thermal rockets.*

PROJECT DESCRIPTION

Nuclear thermal propulsion is an enabling technology for crewed deep space missions. Nuclear thermal rockets (NTRs) offer performance advantages over traditional chemically propelled spacecraft (liquid engines, solid motors, etc.). Key to the development of an NTR is a robust nuclear fuel material that can perform in the harsh high-temperature hydrogen environment of an NTR. Using Center Innovation Fund (CIF) funding, we conducted an investigation to evaluate an innovative nuclear fuel fabrication method. In addition to the fabrication method, we used an original technique to coat fuel particles prior to fabrication. A blend of tungsten metal powder and depleted uranium dioxide particles produced specimens. The blended material was consolidated into a solid mass (see photo). Specimens exhibited high density and a uniform microstructure, suggesting that this material would perform well in an NTR. Future research will focus on a means to transform fuel material into prototypic fuel elements for NTR application.



NASA-SPS-1800C-002 prior to removal of Grafoil. (28.3973 g)

ACCOMPLISHMENTS

This method of fuel fabrication using both the coating method and the innovative consolidation technique with radioactive material is cutting edge. Before FY2016, no one had ever attempted this approach. The preliminary investigation results affirm the approach's potential and pave the way for more extensive research.

BENEFITS

Developing this technology aids deep space exploration, including potential manned Mars missions. Recent research shows the harmful effects the space environment has on the human body, including bone deterioration, radiation exposure, and other adverse health effects; therefore, crew safety for long-duration missions is paramount. By reducing transient times between Earth and mission final destinations, we can improve crew safety significantly. Nuclear thermal propulsion reduces trip times by employing a more efficient propulsion system.

PRINCIPAL INVESTIGATOR: Marvin W. Barnes

FUNDING ORGANIZATION: Center Innovation Fund



Sample NASA-SPS-1800C-002 after removal of Grafoil on ends. (26.0579 g)

Nuclear Thermal Rocket and Arc Jet Integrated System Modeling

OBJECTIVE: *Assess the performance improvement potential of integrating an arc jet or other electric propulsion system with a nuclear thermal rocket.*

PROJECT DESCRIPTION

Advanced propulsion systems capable of high efficiencies are important to deep space exploration missions because these missions' requirements (e.g., propellant quantity, transit time) are challenging. Nuclear propulsion is capable of much higher efficiencies than chemical propulsion, and operates at much higher thrust than electric propulsion, which is also highly efficient. Improving upon nuclear propulsion's efficiencies will support additional mission capabilities. This project seeks to understand the potential gain in performance from integrating an arc jet or another electric propulsion system with a nuclear thermal system. Extra energy, which is generated by the nuclear reactor and added to the propellant, drives the electric propulsion. This process increases propellant temperatures and thus the thrust and efficiency the propulsion system can achieve.

ACCOMPLISHMENTS

After assessing the state of component technologies and determining appropriate assumptions, we built a model to predict performance. We calculated predictions for varying pressure ratios and component efficiencies and determined that the change in performance would increase the specific impulse (efficiency) by approximately tens of seconds, but the change depends upon component technology improvements. With large improvements in electric propulsion efficiency and turbine blade temperature, we could increase the change in performance to around 200 seconds. Higher specific impulse could be possible if we could increase reactor and turbine temperatures beyond current material limitations. The plot shown here shows the specific impulse predicted for arc jet efficiency of 50% and a



Reactor diagram.

turbine temperature inlet of 2,000 K. The performance increases with the pressure ratio, and the specific impulse approaches 990 seconds at the upper limit. The project also completed an initial two-pass reactor design.

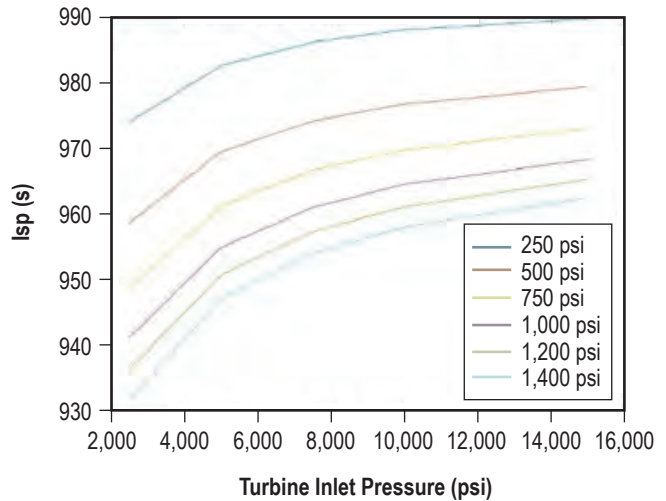

Isp vs Turbine Inlet Pressure for Multiple Chamber Pressures (psi)

BENEFITS

Propulsive efficiency has a large impact upon capability, vehicle type, and cost of deep space exploration. This affects the vehicle size and the quantity of propellant required, and in turn, determines the mission's cost and operational complexity. By increasing propulsive efficiency, the missions become more affordable and easier to achieve. Additionally, we can send more payload to achieve a more ambitious mission.

PROJECT MANAGERS: Brian Taylor and Bill Emrich

FUNDING ORGANIZATION: Center Innovation Fund

Pulsed Lorentz Accelerator

OBJECTIVE: *Proof of concept design, fabrication, and testing of a pulsed plasma thruster for CubeSat and small spacecraft applications.*

PROJECT DESCRIPTION

The Pulsed Lorentz Accelerator (PLA) employs a pulsed high current discharge through an azimuthal coil surrounding a cylindrical chamber to ionize and induce a counter-propagating current in an injected gas propellant. In one version of the thruster, the rapidly rising axial magnetic field the coil current generates pinches the resulting plasma toward the centerline. There, a central cone deflects the inward radial compression into directed axial thrust. In a second version, permanent magnets (or electromagnets) generate strong radial magnetic fields within the discharge chamber; the azimuthal plasma current the coil discharge generates interacts with the strong radial magnetic fields to produce an axial Lorentz body force, accelerating the plasma out of the chamber.

ACCOMPLISHMENTS

During the one-year period of performance, the PLA advanced from an initial TRL-1 concept to prototype design, fabrication, and proof of concept testing. During this period, the project developed an initial thruster scaling analysis; 1D and 2D numerical models are currently in work to understand plasma dynamics and performance better. We designed a pulsed power circuit with capacitors and a spark gap switch to provide the rapidly rising current pulse to the discharge coil. Last, we 3D printed, assembled and insulated both thruster versions with boron nitride, and successfully tested with a static argon backfill in a vacuum chamber. From our work, we submitted a NASA New Technology report.

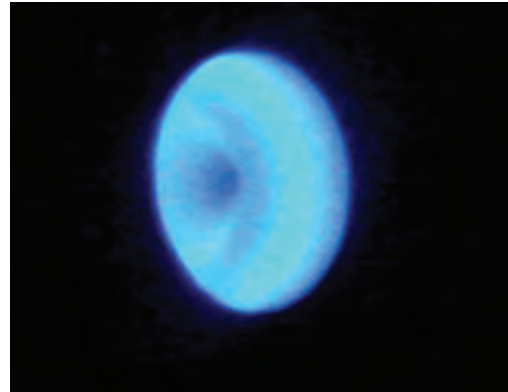

Vacuum chamber tests with argon propellant.

BENEFITS

This initial investigation focused on developing a low-power PLA thruster with potential applications to CubeSats and small spacecraft, where current propulsion options are very limited. A compact plasma thruster offering larger total impulse capabilities than current systems would provide significant mission benefits, and is the most likely near-term market for the system. Ion and Hall thrusters operate very efficiently at low- to mid-kW power levels, so we do not anticipate that the PLA will find a unique niche in this power range. As power levels increase to 100 kW and beyond, however, the options for in-space electric propulsion begin to diminish again, and the PLA may offer distinct advantages over other high power propulsion concepts.

PROJECT MANAGERS: Michael LaPointe, PhD; Kurt Polzin, PhD

FUNDING ORGANIZATION: Center Innovation Fund

Linear Transformer Drivers

OBJECTIVE: *Create high-efficiency pulsed power systems for advanced propulsion and power.*

PROJECT DESCRIPTION

The Linear Transformer Driver (LTD) is a revolutionary new technology that has applications in propulsion and power. Pulsed power systems generally store energy in capacitors and release that energy in a short burst. Adequate time compression of the burst is essential to raise the temperatures of operating plasmas, and to encourage compression of the plasma. The LTD can compress an electrical current by a high factor, replacing a traditional Marx bank in a pulsed power application. LTDs can reach efficiencies of nearly 80%, with a required mass potentially a factor of 10 lower than a comparable Marx bank. LTDs can revolutionize fusion and other pulsed power applications' size. Additionally, LTDs scale well from tabletop to terawatt applications. This technology has broad application and can be developed incrementally.

ACCOMPLISHMENTS

At the beginning of the year, we had completed the first of a two-year program to develop LTDs. Last year, we made a cavity fire consistently at low voltages, using switching systems developed in-house. This year, we developed a much more compact device using barium-titanate derivative materials developed at Marshall Space Flight Center (MSFC) by other researchers.

We developed a high-power testing area with remote switching and capacitors with discharge times of tens of nanoseconds, all within a test system designed to reach 8 kV. We also completed designs to integrate the

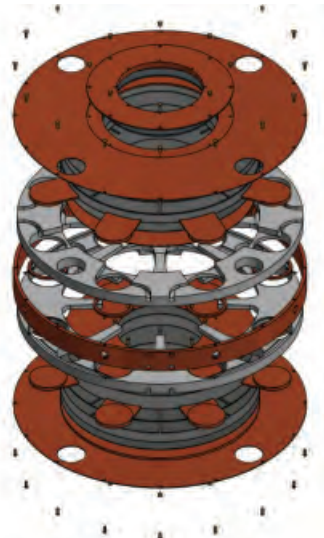

Prototype linear transformer driver.

cavity (shown in exploded view) into a stack of cavities and eventually a super-brick of cavities for eventual integration into a system of ~10,000 cavities that will produce about 2 MV at 2 MA at ~100 ns. This is approximately equal to several hand grenades, and the highly compressed discharge time results in the ability to compress targets to a fraction of their original size.

BENEFITS

LTDs have strong application in the field of pulsed power generation for propulsion devices. The proposers have investigated this technology hoping to apply it to a fission-fusion hybrid. One critical issue with fusion propulsion applications is the minimum size needed to achieve breakeven fusion. Both space-based and terrestrial applications have tried to limit the peak power input to minimize the size of the propulsion system or ground-based power plant, respectively. LTDs promise to reduce the mass of the system by as much as a factor of 10, to more easily justify higher power levels to overcome radiative losses and plasma instabilities. LTDs could enable breakeven fusion, and at masses much lower than previous studies indicate. An LTD-powered fusion propulsion system is predicted to fit within a single SLS Block II launch. Imagine a vehicle that could fly anywhere in the solar system with only two or three SLS launches for initial assembly.

Imagine also a power plant that could power a small town and take up the footprint of a medium/large house. LTDs can revolutionize how we look at in-space propulsion and fix national issues such as oil dependence, pollution from energy production, and our power grid's vulnerability to attack.

PROJECT MANAGER: Robert B. Adams

FUNDING ORGANIZATION: Center Innovation Fund

Pulsed Plasma Thruster for CubeSats

OBJECTIVE: *Design, build, and test a pulsed plasma thruster that generates 1,000 seconds of ISP and fits within a 1U CubeSat body.*

PROJECT DESCRIPTION

Pulsed plasma thrusters are extremely dependable electric thrusters. This research was to use two technologies currently in development at Marshall Space Flight Center (MSFC)—linear transformer drivers (LTDs), and ultracapacitors—to miniaturize and improve the thruster’s efficiency. For this study, we designed and constructed a prototype thruster and tested it in the laboratory. We were not able to source the ultracapacitor and optimize the design to fit into the CubeSat body.

ACCOMPLISHMENTS

During FY2016, we selected the propellant type that we want to study further. We also designed and constructed a feeder system and completed a preliminary mission analysis of a CubeSat outfitted with a thruster. We designed and constructed a test article, which Figure (a) shows, and tested the thruster in open air and in a vacuum, depicted in the (b) and (c) figures. Finally, we developed a charging circuit for the test article; there were fabrication issues with the ultracapacitor.

BENEFITS

We are attempting to design a CubeSat-sized thruster that has the performance and dependability of a pulsed plasma thruster, a technology that has been around since the beginning of the space age. Should we succeed, it will be able to send CubeSats beyond Earth’s orbit. This would benefit any organizations that want to send CubeSats on interplanetary journeys.

PROJECT MANAGER: Andrew Schnell

FUNDING ORGANIZATION: Technology Investment Program

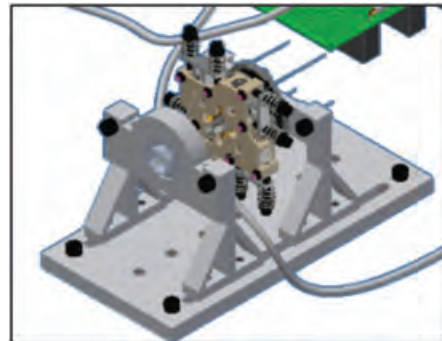

(a) 3D rendering of test thruster.

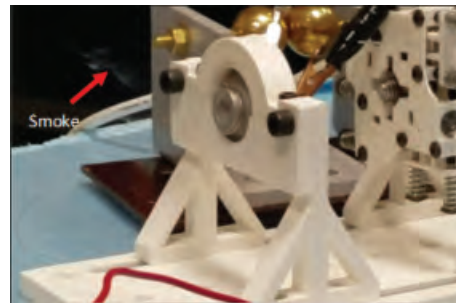

(b) Test article during open air testing; note the smoke emanating from the thruster.

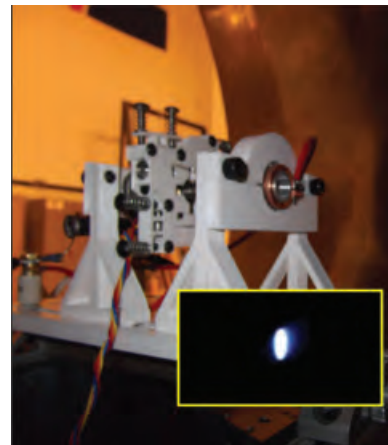

(c) Test article in the vacuum chamber and during testing (see inset).

Small Spacecraft Green Propulsion System Development

OBJECTIVE: *Development and maturation of green micropropulsion technologies for small spacecraft.*

PROJECT DESCRIPTION

Over the past decade, the market for small spacecraft has grown dramatically. The primary attraction to these small spacecraft is their affordability relative to more conventionally sized spacecraft, and because of this, the range of users has expanded from large government and industry organizations to small companies and universities. Typically, these small spacecraft are flown as secondary payloads on a launch vehicle, which allows them to share the launch costs with multiple payloads and drastically reduce their overall mission cost. While many of the technologies currently employed on conventional spacecraft are directly transferable to these smaller spacecraft, others, such as propulsion technologies, require a great deal of development effort in order to scale down to the required mass and volume constraints imposed for these smaller spacecraft while still maintaining comparable performance to the traditional systems. In addition to the obstacles associated with scaling, there are also safety concerns associated with the propellants that are traditionally used in these high-energy chemical propulsion systems. Therefore, there has also been a push within the industry to develop safer, less toxic alternatives to the traditional chemical propellants.

This project sought to combine these two development efforts and was focused on low-toxicity propulsion system development for small satellite applications. This type of work has been ongoing at Marshall Space Flight Center (MSFC) for the past few years, and this project was intended to bring many of those individual efforts together to demonstrate full system-level development and technology maturation.

ACCOMPLISHMENTS

At the beginning of FY2016, many of the technologies associated with this project had been in development over the past few years. Individually funded development efforts had looked at maturation of specific components within a traditional propulsion system, namely the propellant tank, isolation valve(s), and the thruster. This effort sought to combine all those into a single integrated system and demonstrate operation at a system level. During the course of the effort, issues were discovered within the development thruster design which required a redesign of the hardware. We used new materials for the chamber to increase life, designed a new injector to improve spray pattern, updated heater designs to be more flight-like, and updated interfaces to the thruster to ease integration.

At the completion of the effort, we completed successful hot-fire demonstration of the system. There are still some issues to work within the thruster and overall system design, but the operation of the system was demonstrated.



Left: PPI 1-N and 100-mN thruster reactors. Center: 100-mN thruster post hot-fire test. Right: 1-N thruster in Cell A.

BENEFITS

The case for this work is two-fold. First, maturation of small spacecraft technologies is consistent with the current trends and interests within the space community. As previously stated, these small spacecraft open the door to so many more end-users than do traditionally sized spacecraft. The industry has sought to standardize the size (mass and volume) of these spacecraft early on, and because of that, there has been significant development to provide off-the-shelf components for the various “standard” sizes. With standardization, their relative size, and the ability to share launch costs, the overall costs are much more affordable relative to traditional spacecraft. However, some of the capabilities of larger spacecraft (namely high-energy propulsion systems) have not yet been developed for these small spacecraft, and therefore, the capabilities of the missions they are used for are limited. This effort sought to work toward closing that gap and providing an “off-the-shelf” design for a propulsion system that could provide added capabilities to a small spacecraft mission.

Additionally, as more and more people get involved with these small spacecraft and the need for high-energy propulsion systems grows, there will be increasing scrutiny and a growing desire to make these systems safer. Lower toxicity alternatives and their associated systems will therefore require additional development and maturation to satisfy this desire. In short, the benefit of this work is it will provide a safe and affordable capability that currently does not exist to an emerging market within the space industry.

PROGRAM MANAGERS: Jason Adam, Hunter Williams, Chris Burnside

FUNDING ORGANIZATIONS: Center Innovation Fund, Technology Investment Program

Dual Mode Green Propulsion Proof of Concept

OBJECTIVE: *Demonstrate proof of concept for dual mode green propulsion system for small spacecraft.*

PROJECT DESCRIPTION

This project comprises a cooperative agreement between NASA Marshall Space Flight Center (MSFC) and Massachusetts Institute of Technology (MIT) to demonstrate a bimodal propulsion system concept based on the green propellant AF-315E. This project will develop an integrated propulsion system with a single propellant reservoir used to feed both a chemical combustion engine for high thrust operation and a Micro Electro Spray Propulsion (MEP) unit for high specific impulse operation, initially targeting small spacecraft propulsion and small satellites. If successful, the concept is well suited for propulsion demanding missions within NASA, but it also has broad applicability to Department of Defense (DoD) and in commercial markets.

Both the combustion engine and the MEP thrusters have operated on AF-315E with excellent performance. However, the combustion engine requires high-pressure propellant to feed the thruster, while the MEP thrusters typically are preloaded and use unpressurized fluid transfer. This effort will demonstrate the propellant feed system's experimental critical function to both thrusters, and demonstrate a characteristic proof of concept approaching the integrated system's TRL-3.

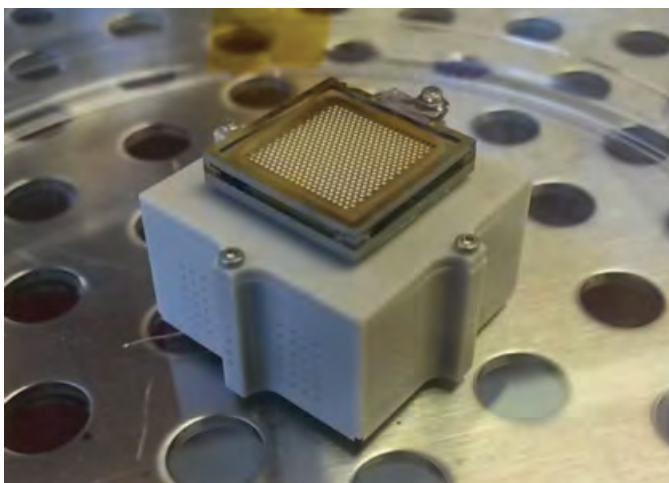

The AF-315 MEP.

ACCOMPLISHMENTS

The project officially began in May of 2016. At the end of September, the integrated system design was complete, MIT delivered an electro spray system to MSFC, and MSFC successfully performed time of flight measurements of the electro spray system with the AF-315 propellant. Additionally, MSFC completed performance testing of the combustion thruster at the component level. All individual components are available now for system level integration, and on track for an early project completion.

BENEFITS

This bimodal propulsion system's innovation would simplify the spacecraft by attempting to use two high-performance propulsion options at high and low thrust from a single propellant reservoir. Using the AF-315E with the MIT MEP thrusters and a combustion engine offers significant packaging advantages over independent combustion and electric propulsion options. Another advantage of the dual mode system is that it affords the spacecraft high flexibility without being forced to choose between high thrust and high specific impulse prior to a mission.

PROGRAM MANAGERS: John Dankanich, Chris Burnside, Kurt Polzin

PARTNER PRINCIPAL INVESTIGATOR: Paulo Lozano, Massachusetts Institute of Technology

FUNDING ORGANIZATION: Cooperative Agreement Notice

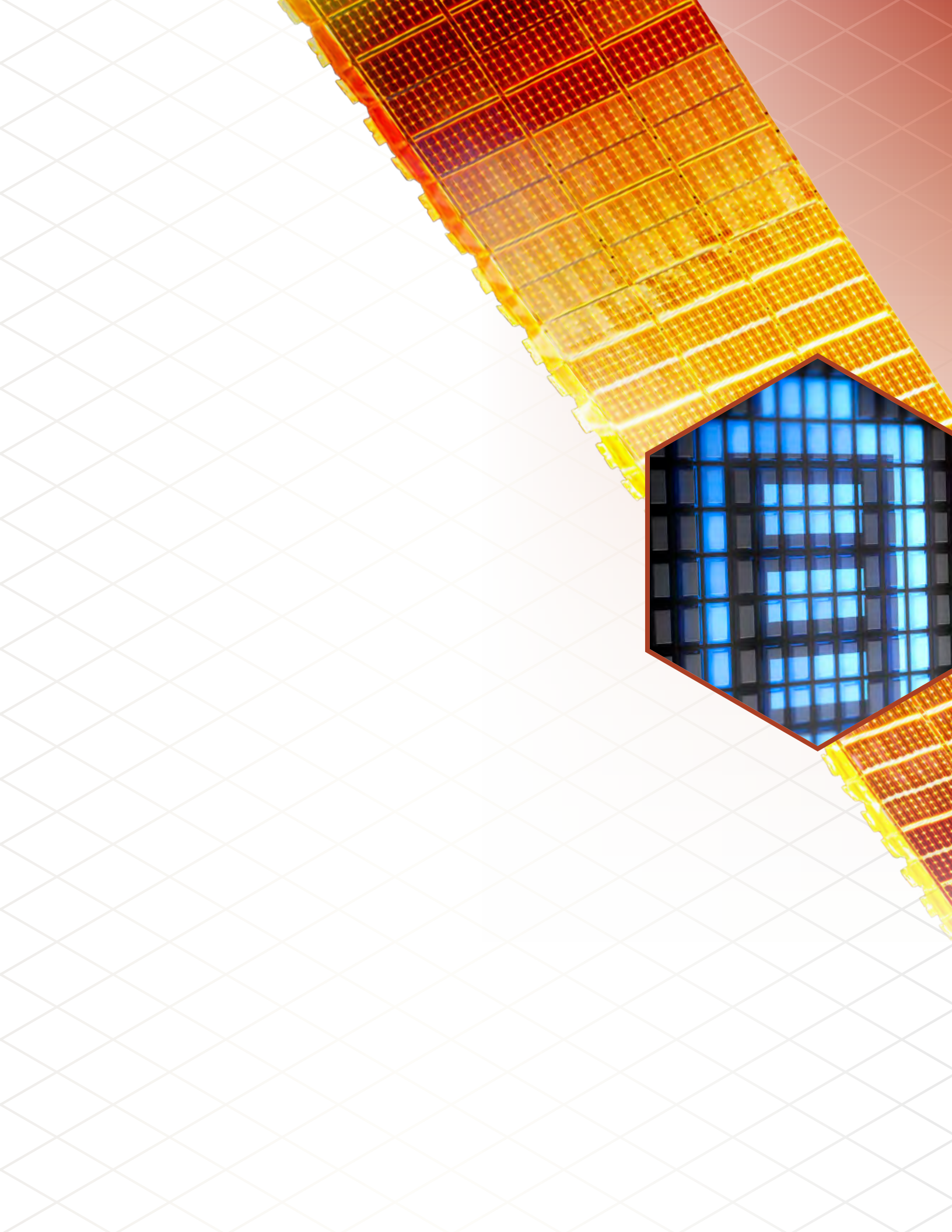

POWER AND ENERGY STORAGE

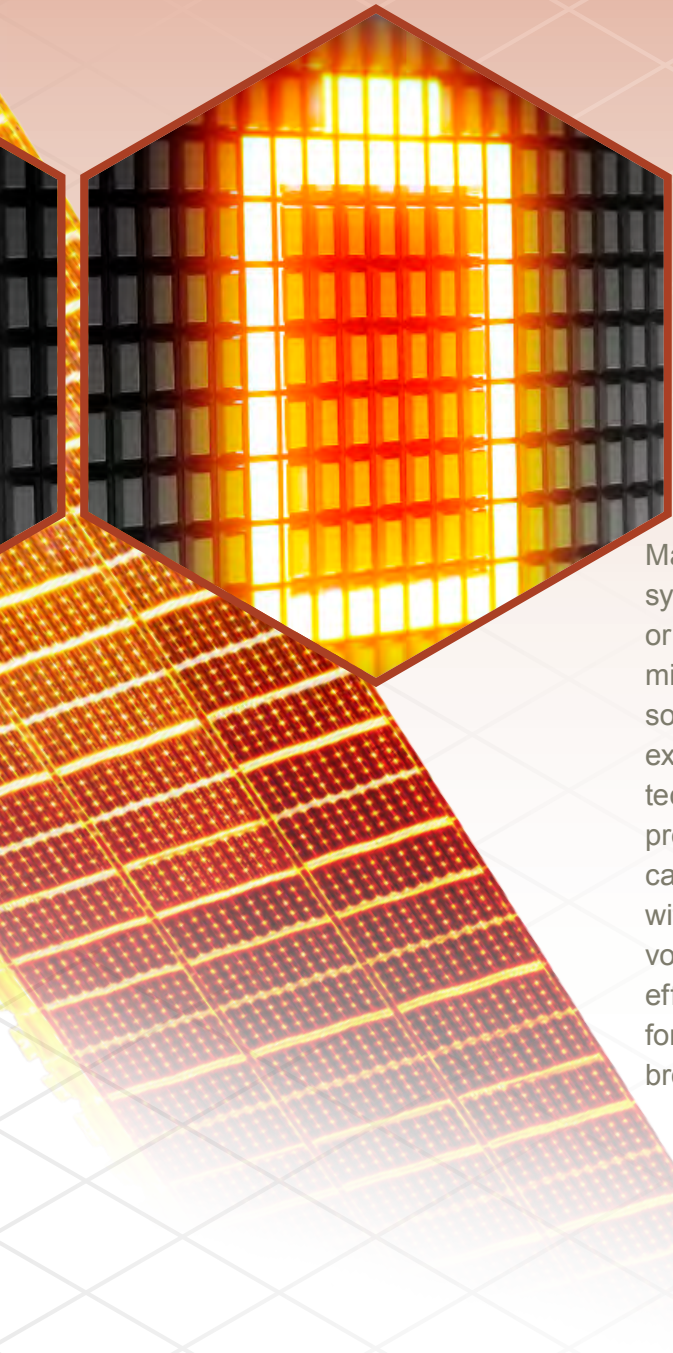

Many state-of-the-art power systems are too heavy, bulky, or inefficient to meet future mission requirements, and some cannot operate in extreme environments. The technology developments presented in this roadmap can produce power systems with significant mass and volume reductions, increased efficiency, and capability for operation across a broad temperature range

and in intense radiation environments.

Power systems are enabling for every robotic and crewed mission, for both science and human exploration. They typically comprise up to a third of a spacecraft's mass. Power systems are made up of power generation, energy storage, and power management and distribution subsystems.

High-Temperature Thermoelectrics

OBJECTIVE: *Produce oxide thermoelectrics capable of use above 1,000° C.*

PROJECT DESCRIPTION

This project's purpose is to produce high-temperature oxide thermoelectrics to use in Radioisotope Thermoelectric Generators (RTGs). These generators are used as a power source for planetary probes. Doping adds elements, usually in parts per million, to a material, which increases the material's semiconducting behavior. For this project, doped strontium titanate and doped ZnO will be the thermoelectric materials. The ultimate goal is to produce a thermoelectric that is cheap, non-toxic, and can be used above 1,000° C.

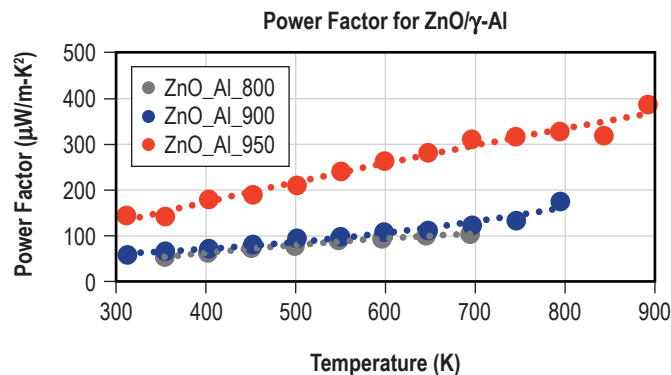

Power factor for nanopowder sample at different temperatures.

ACCOMPLISHMENTS

Nanopowders of ZnO doped with gamma aluminum oxide were sintered in a Direct Current Sintering Furnace (DCS). The DCS lets us sinter powders to full density in minutes while retaining fine grain structure. The accompanying chart shows the power factor for these samples at different temperatures.

We have also produced samples which are reprocessed to obtain nanophases as well as mesophases in order to scatter more phonons. That will reduce thermal conductivity and increase thermoelectric figure of merit. We have also made samples of ZnO co-doped with gamma alumina and gallium oxide and they are ready for testing. Processed samples of lanthanum-doped and niobium-doped strontium titanate are awaiting thermoelectric testing as well.

BENEFITS

This work, if successful, will provide a thermoelectric material that is an alternative to what we use now in RTG. These materials are expensive to produce, toxic, and can sublime at high temperatures. The proposed oxide thermoelectrics are inexpensive, easy to produce, non-toxic, and can be used in vacuum without problems. In addition, they have a higher upper use temperature, which means that thermoelectric generator efficiency will be higher than that now achieved.

PROJECT MANAGER: Dr. Dennis S. Tucker

FUNDING ORGANIZATION: Center Innovation Fund

Optimization of Ultracapacitors

OBJECTIVE: *Develop critical parts that will aid in ferroelectric ultracapacitor design for optimal energy storage.*

PROJECT DESCRIPTION

A solid-state ultracapacitor is an electrical component that offers significant advantages over current electrochemical and electrolytic devices. This project was established to further the research and development activities of the Solid State Ultracapacitor project originally developed at Marshall Space Flight Center (MSFC). Currently, the number of different methods of building an ultracapacitor is extremely large and complex. The University of Alabama in Huntsville (UAH) has unique expertise and modeling capabilities to minimize the variables in complex ferroelectrics. This project was established to determine which parameters are important, that is, which ones have the greatest effect on energy storage, capacitance, voltage breakdown, etc.

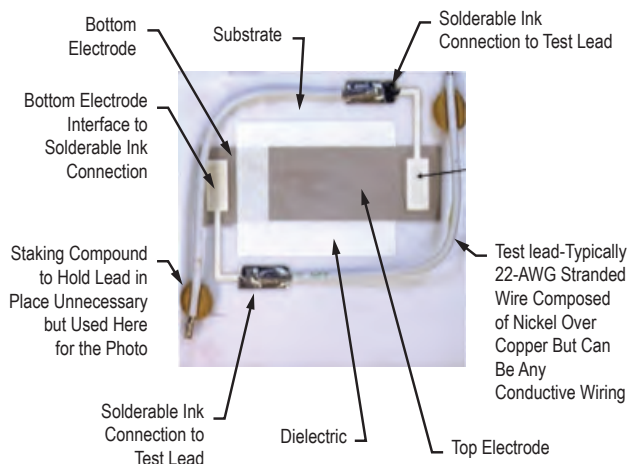

Example of an unpackaged ultracapacitor used for testing. This design is screenprinted for ease of manufacture and represents one 30-50 micron layer of dielectric bounded by a top and bottom electrode.

ACCOMPLISHMENTS

At the beginning of this project, devices showed charging times in milliseconds, large breakdown voltages in a 30-micron layer, and demonstrated an ability to activate LEDs. However, reproducing these characteristics was challenging. The MSFC/UAH collaboration found that we could change many processing

parameters to improve device properties. One example was nanoparticle treatment. Data UAH acquired clearly indicated that pretreatment versus post treatment was an area critical for increasing capacitance and, subsequently, energy storage. We produced a final parametric model where users can input design characteristics and get an output of resulting device behavior. The plot here shows one of the poorer performing samples that was the result of non-optimized coating and post processing. Due to the results of this effort, MSFC has a more optimized way of producing devices that have the characteristics our customers desire.

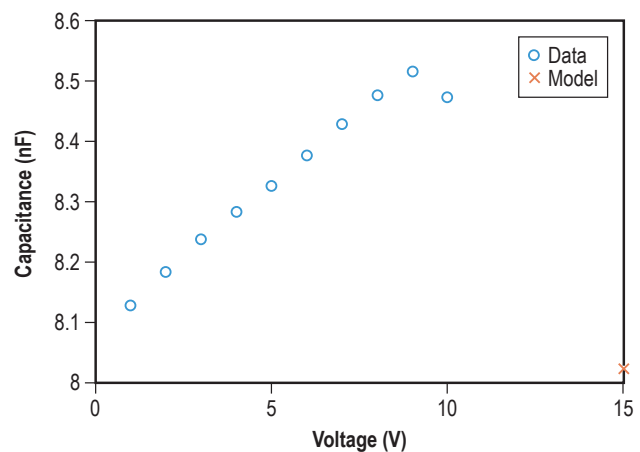

Plot from parametric model predicting that capacitance for this particular set of processing conditions is optimized at 9 V and that higher voltage will greatly reduce the capacitance and, subsequently, the energy storage.

BENEFITS

By minimizing unnecessary variables, the time from design to optimized device was decreased considerably. Additionally, other ferroelectric devices can use the outcome and deliverable, a parametric model. The results generated an optimized processing, which improves the likelihood that this technology will be available commercially in the near future.

MSFC TECHNICAL POC: Dr. Terry D. Rolin

PARTNER PRINCIPAL INVESTIGATORS: Dr. F. D. Ho and Ms. Caroline John, University of Alabama in Huntsville

FUNDING ORGANIZATION: Cooperative Agreement Notice

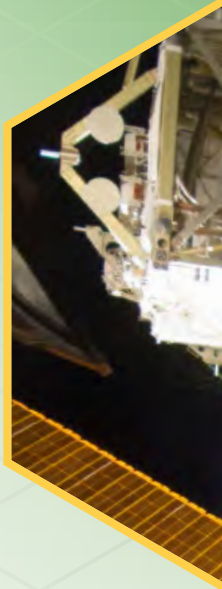



AUTONOMOUS SYSTEMS

The goal of robotics and autonomous systems is to extend our reach into space, expand our planetary access capability and our ability to manipulate assets and resources to help us understand planetary bodies using remote and in situ sensors, prepare them for human arrival, support our crews in their

space operations, support the assets they leave behind, and enhance the efficacy of our operations. Advances in robotic sensing and perception, mobility and manipulation, rendezvous and docking, onboard and ground-based autonomous capabilities, and human-systems integration will drive these goals.



Autonomous Mission Operations—Expedite the Processing of Experiments to Space Station-2

OBJECTIVE: *To demonstrate an innovative, flexible automation software incorporating fault detection and isolation logic.*

PROJECT DESCRIPTION

Autonomous Mission Operations—Expedite the Processing of Experiments to Space Station-2 (AMO–EXPRESS-2) provides a crew interface to command EXPRESS racks and test crew autonomous operations. The experiment concept is for an International Space Station (ISS) crewmember on-orbit to operate EXPRESS Rack 7 power up and configuration (Activation) and power down (Deactivation) onboard using single button function procedures.

ACCOMPLISHMENTS

The AMO–EXPRESS-2 experiment was executed successfully in June 2016. The experiment’s objective



Screenshots from the successful test of the AMO–EXPRESS software onboard ISS in 2016.

was to prove the crew could nominally deactivate, then reactivate EXPRESS Rack 7 alone, without any ground support, via onboard autonomous software. The ISS crew executed a single button function to deactivate and then reactivate EXPRESS Rack 7. They executed the single button function using Timeliner (Automated)

procedures from the WebPD application residing on the Payload Portable Computer System (PCS) laptop. These demonstrations were completely successful. The overall AMO investigation purpose was to demonstrate on-board crew autonomy techniques for future deep space human spaceflight missions and habitations.

BENEFITS

This autonomous operations capability proved that possible scenarios such as a medical facility initialization to respond to a crew medical emergency was representative of other spacecraft autonomy challenges. The autonomous operations concept includes a reduction of the amount of data a crew operator is required to verify during activation or deactivation, as well as integration of procedure execution status and relevant data in a single integrated display. Prior to the demonstration, astronauts could not perform this activity.

PROJECT MANAGERS: A. Haddock, Marshall Space Flight Center; Jeremy Frank, Ames Research Center; Lui Wang, Johnson Space Center

FUNDING ORGANIZATION: Advanced Exploration Systems

MSFC Autonomous Systems and Operations

OBJECTIVE: *Develop and demonstrate autonomous systems to serve habitats when crew is not present, provide software tools to reduce the crew's dependence on ground-based mission control, and demonstrate autonomous systems and operations capabilities and requirements as a proof of concept.*

PROJECT DESCRIPTION

This project's focus is to demonstrate integrated vehicle systems automation and crew situational awareness technology for autonomous operations of the Expedite the Processing of Experiments to Space Station (EXPRESS) rack on the International Space Station (ISS).

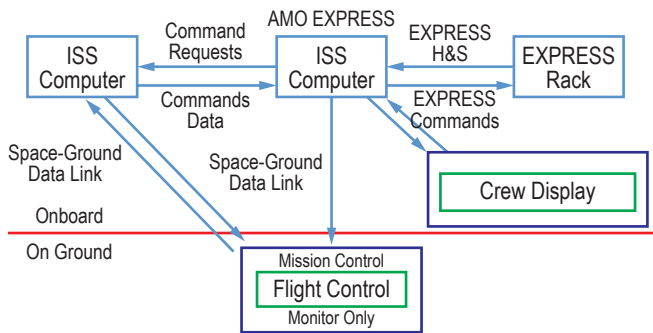

Flowchart of the various software processes required to autonomously operate the EXPRESS rack.

ACCOMPLISHMENTS

In 2015, the Autonomous Systems and Operations (ASO) project conducted an autonomous command and control experiment onboard the ISS that demonstrated single-action intelligent procedures for crew command and control. The experiment permitted facility-class rack initialization with power and thermal interfaces involving core and payload command and telemetry processing without support from ground controllers.

The experiment was conducted using the EXPRESS Rack 7. In 2016, with ISS astronauts initiating the operations instead of ground controllers, the Autonomous Mission Operations (AMO) EXPRESS experiment demonstrated the activation and deactivation of

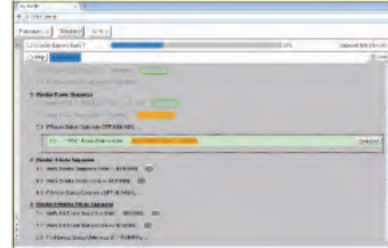

Screenshot of the software in operation on ISS.

EXPRESS Rack 7, providing the capability of future single button activations and deactivations of facility-class racks. The experiment achieved numerous technical and operations firsts for the ISS.

BENEFITS

This more capable software will let future crews manage complex spacecraft systems and experiments autonomously during future exploration missions. NASA will require autonomous mission operations to simplify operations when the crew of the spacecraft is far away from Earth, as communication with the ground will incur long latencies and outages.

PROJECT MANAGERS: A. Haddock, Marshall Space Flight Center; Jeremy Frank, Ames Research Center; Lui Wang, Johnson Space Center

FUNDING ORGANIZATION: Advanced Exploration Systems



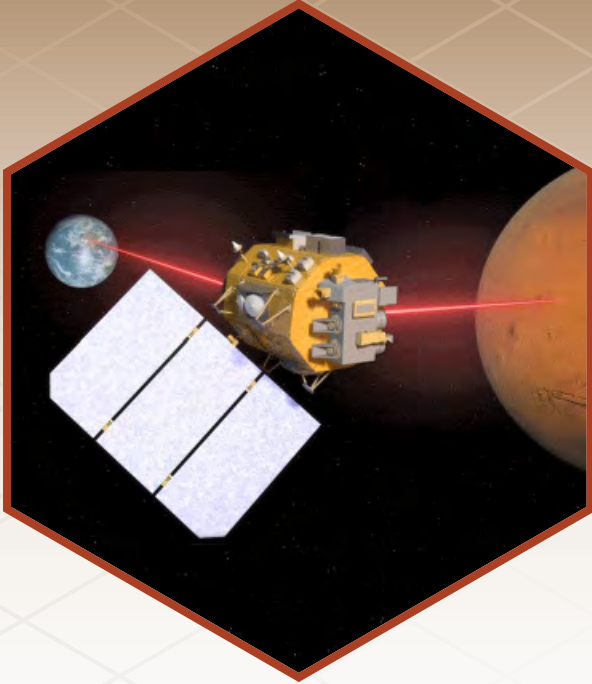

COMMUNICATION AND NAVIGATION

The communication and navigation technology area focuses on increasing the performance and efficiency of communications, navigation, orbital debris tracking, and orbital debris characterization. Specific goals are increased data rates for communication devices without adding any additional mass, volume, or power requirements to the missions; increased security

of data transfer; and assured data delivery throughout the solar system based on autonomous systems and/or network connectivity. Some navigation goals are to provide more accurate vehicle tracking to reduce errors in trajectory; entry, descent, and landing; and rendezvous procedures. Additionally, the ability to track more vehicles simultaneously and automated trajectory planning are goals for the next 20 years.



Propellantless Attitude Control of Solar Sails Using Reflective Control Devices

OBJECTIVE: *Develop a material with switchable reflectivity to “turn” a small satellite propelled by solar sails.*

DESCRIPTION

The Propellantless Attitude Control of Solar Sails Using Reflective Control Devices project started out as a Space Technology Research Grants Program Early Career Faculty (ECF) grant to researcher Jeremy Munday of the University of Maryland (UMD) in College Park, Maryland. The project transitioned into the Small Spacecraft Technologies (SST) Program with follow-on funding from a Smallsat Technology Partnership award. The SST project will develop solar sails that can alter their properties electronically, letting them switch between reflective and transparent states, and resulting in the ability to maneuver or change the attitude of smallsats.

Operational Schematic: As PDLs are activated along half the solar sail’s edge, a rotational motion can occur, performing a maneuver or attitude change.

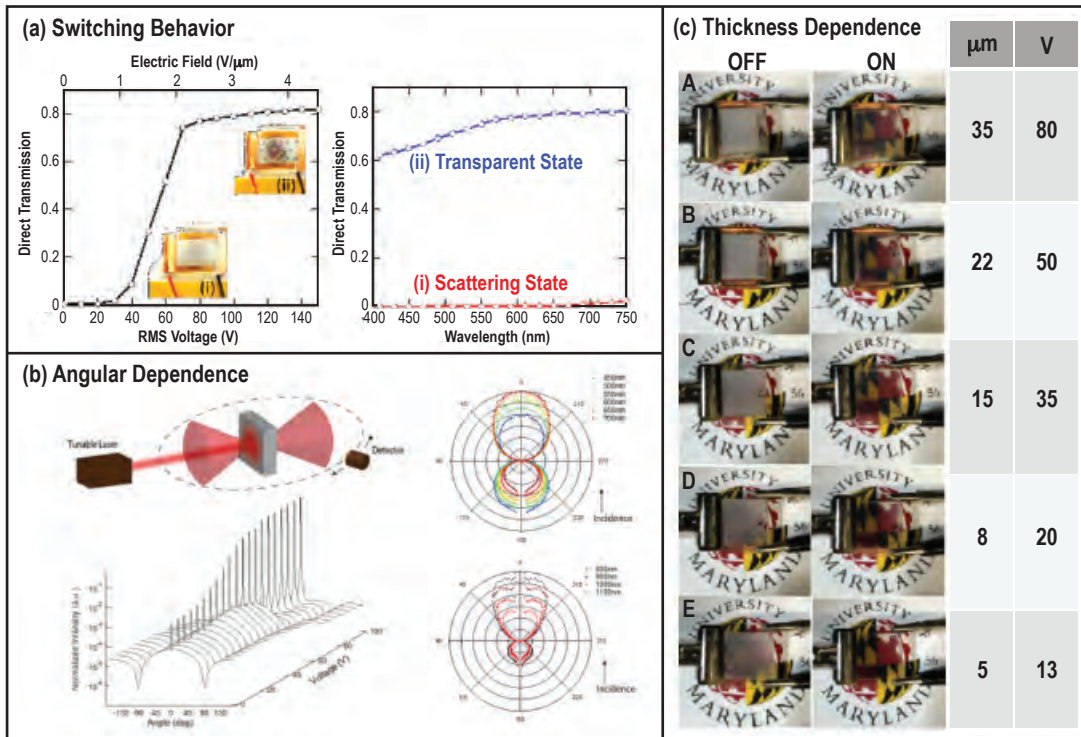
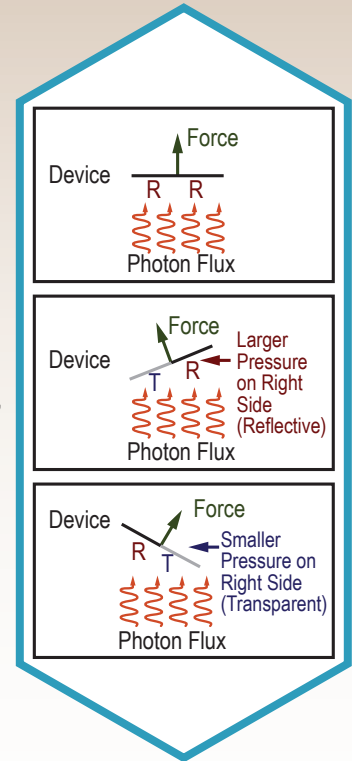

Characterization of PDLC: (a) Demonstration of the switching behavior between transparent and scattering states; (b) Analysis of the angular dependence with respect to the angle of light coming into the PDLC, the intensity of the light, and the amount of voltage needed to switch the device for effectiveness; (c) Relation between the thickness of the material versus the voltage needed to activate the device: thicker = more required voltage.

feature

SUCCESS STORY

The original ECF project measured the radiation pressure exerted on materials with an atomic force microscope-based technique, and involved developing methods to achieve switchable reflectivity. Switchable reflectivity required us to develop several new materials, including metamaterials, whose optical properties are not found in nature. We tested one of the metamaterial designs in orbit as a secondary payload on an X-37B launch aboard an Atlas 5 in

May 2015. The technology of interest to SST is based on a polymer-dispersed liquid crystal (PDLC) film, which can switch between transparent and diffusely reflective when a voltage is applied. We expect this technology to provide a 3× improvement in steering over previous efforts. Within SST, we expect advancement from TRL-3 to TRL-4 over the next two years, setting the stage for prototype flight validation.

Devices in operation:
Demonstration of the PDLCs
in operation at the University
of Maryland College Park.



BENEFIT

Propellantless attitude control using an electrically switchable optical film will obviate the need for traditional control methods involving reaction wheels and propellant ejection, which severely limit mission lifetime. Eliminating the need for propellant will reduce weight and cost while improving performance and lifetime.

LEAD CENTER: Marshall Space Flight Center

PROGRAM MANAGER: Tiffany Russell Lockett

FUNDING ORGANIZATION: Space Technology Mission Directorate, Small Spacecraft Technology Program

Delay and Disruption Tolerant Network

OBJECTIVE: *Build an internet architecture for the future Solar System Internet (SSI).*

PROJECT DESCRIPTION

Delay and Disruption Tolerant Network, or DTN, is a combination of protocols being developed to extend the terrestrial Internet into low-Earth orbit and deep space to help form the backbone of the future SSI. The Advanced Exploration Systems (AES) DTN project will prepare DTN technologies and operations concepts for the next generation of human spaceflight missions to use when AES projects, Exploration Systems Division programs (Orion/Multipurpose Crew Vehicle, Space Launch System, and KSC/Ground Systems Development and Operations) and the International Space Station (ISS) adopt the technology. We will emphasize developing “implementation ready” sets of DTN components and operations concepts to support rapid update and infusion of DTN into NASA’s space communication architecture. We will also emphasize international standardization of DTN through the Internet Research Task Force and/or Internet Engineering Task Force.

While NASA’s DTN-related activity is expected to continue through the operational deployments of DTN on future missions, the AES DTN project’s focus is to transition away from a developmental role and into an infusion and mission support role for those technology elements reaching maturity. Another focus of the

AES DTN project is on human space exploration, but other developing DTN protocols should also benefit other NASA missions such as robotic deep space, low Earth-orbit, near-Earth orbit, and terrestrial applications.

ACCOMPLISHMENTS

NASA infused DTN technology on ISS when the Huntsville Operations Support Center collaborated with JSC ISS flight and ground engineering to deploy a DTN architecture to support ISS operations and payload teams. This activity began in late 2014, while the hardware and software eventually deployed to support real time ISS operations on May 5, 2016.

BENEFITS

DTN lets ISS payload developers automate and streamline their control center operations. The technology permits automatic re-transmission of payload telemetry that may have been disrupted by space link issues. This cuts down on the number of playbacks the payload developers must perform to fill these gaps, which also helps maximize the bandwidth use on the space link between ISS and ground.

LEAD PROJECT MANAGER: Brenda Lyons, Johnson Space Center

MSFC SUPPORTING PROJECT MANAGER: Kelvin Nichols

FUNDING ORGANIZATION: Advanced Exploration Systems

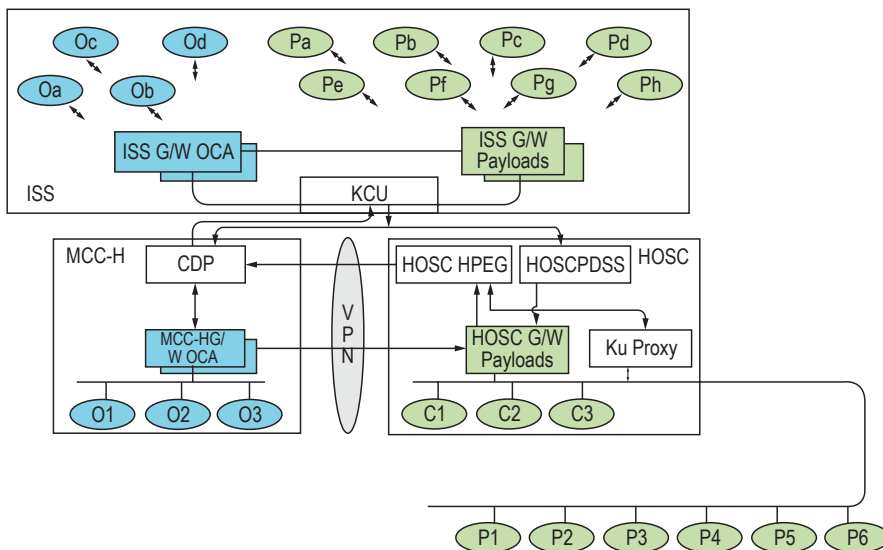

Diagram of the ISS Delay Tolerant Network implementation.

- Pa – Ph = Payload a – Payload h (payload computers)
- Oa – Od = Operations a – Operations d (Operations computers)
- G/W = Gateway
- KCU = Ku Communications Unit
- CDP = Command Data Processor
- MCC-H = Mission Control Center – Houston
- OCA = Operations Communication Adaptor
- O1-O3 = Operations 1 – Operations 3 (ground Operations computers)
- VPN = Virtual Private Network
- HOSC = Huntsville Operations Support Center
- HPEG = HOSC Payload Ethernet Gateway
- PDSS = Payload Data Service System
- C1-C3 = Cadre 1 – Cadre 3
- P1-P6 = Payload 1 – Payload 6

Fast-Light Enhanced Fiber Gyroscope

OBJECTIVE: *Develop a fiber laser gyroscope with small size and high performance, robust enough for demanding environmental conditions in spacecraft and autonomous vehicles.*

PROJECT DESCRIPTION

A major requirement to operate spacecraft, naval vehicles, and aircraft reliably is accurate navigation without constant human input. Oftentimes, we can accomplish this using a global positioning system (GPS), but GPS cannot guarantee reliability when inclement weather, electronic jamming signals, or geography interfere with normal operation. GPS is also useless in spacecraft with no direct link to the GPS constellations. Inertial measurement units (IMUs) fill in these gaps by measuring a vehicle's actual rotations and acceleration. Meeting navigation goals demands highly sensitive gyroscopes and accelerometers, but size, weight, and power (SWaP) are extremely precious resources in spacecraft and other vehicles (e.g., unmanned aerial vehicles, or UAVs). Enhancing the sensitivity of existing devices, reducing their size, or both can let us use inertial navigation in smaller airframes, or free up room to include larger mission payloads for scientific or military purposes. Using fast-light phenomena in a fiber where nonlinear optical effects can increase the performance of an optical gyroscope or accelerometer dramatically, we will develop IMUs that will deliver much higher performance and lower SWaP than a traditional IMU system.

ACCOMPLISHMENTS

At the beginning of FY2016, published academic literature presented strong theoretical and experimental evidence of basic physics and system requirements for practical fast-light enhanced optical sensors. Previous results from MagiQ Technologies (obtained through SBIR research grants) had demonstrated significant fast-light effects experimentally with commercially available fiber and optical components. MagiQ Technologies began work on Phase I of their SBIR grant in July of 2016. Since that time, they have presented results including the impacts of various environmental effects

on the enhanced gyroscopes, and integration results from a lab demonstration of a ring laser gyroscope. Additionally, they continued work on passive and active gyroscope stabilization against any environmental effects.

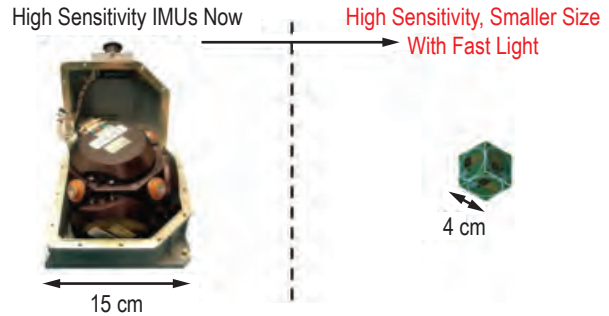

Fast light phenomena could allow significant reductions in the size, weight, and mass of inertial measurement units.

BENEFITS

Some particular applications could benefit immediately from the availability of small SWaP IMUs with high sensitivity, such as those being developed in this program. Among those are tracking and control of launch vehicles for placing payloads into orbital or suborbital trajectories, precision inertial feedback during orbital maneuvers or station keeping operations on manned or unmanned spacecraft, and actively stabilizing instrument platforms during sensitive astronomical observations or scientific measurements.

PROJECT MANAGER: Caleb Christensen

FUNDING ORGANIZATION: Small Business Innovative Research

Fast-Light Enhanced Active Gyroscopes, Accelerometers, and Fiber-Optic Sensors

OBJECTIVE: *To develop superluminal ring laser-based gyroscopes, accelerometers, and fiber-optic sensors with sensitivities highly enhanced by the fast light effect.*

PROJECT DESCRIPTION

Under this project, we are developing fast-light-based sensor technology in two parallel paths: a rubidium vapor Raman laser-based Active Fast-Light Optical Gyroscope/Accelerometer (AFLOGA), and a fiber Brillouin laser-based Active Fast Light-Fiber-Optic Sensor (AFLIFOS). Both of these systems will be able to act as gyroscopes and accelerometers simultaneously. In addition, the AFLIFOS will be a very sensitive sensor for strain and temperature. In the final form, the superluminal inertial measurement units (SIMUs) produced with these technologies should be over four orders of magnitude more sensitive than current state-of-the-art inertial measurement units. Our goal is to demonstrate, test, and characterize a laboratory-scale AFLOGA, and then use the knowledge we gain to design, construct, and test a compact AFLOGA that will fit in a 10-cm- \times -30-cm- \times -30-cm case. We will develop a design for a complete, six-axis SIMU with a footprint comparable to commercial inertial measurement units, but with dramatically higher sensitivity. In parallel, we will design, construct, and test a laboratory-scale AFLIFOS system.

ACCOMPLISHMENTS

Begun in mid-April of 2016, at the end of the FY2016, we have: (a) assembled a complete AFLOGA setup, which includes a monolithic chamber with two vapor cells, six pump lasers, and many servos; (b) used this setup to demonstrate, for the first time, a pair of counter-propagating and spatially overlapping superluminal ring lasers (SRLs) employing Raman gain and depletion, realizing a basic AFLOGA—refinement of detection optics and electronics in progress to measure rotation and acceleration; (c) finalized a detailed AFLIFOS design, with assembly of all components for the AFLIFOS in progress, and with preprint ready to submit for publication; (d) analyzed prior observation

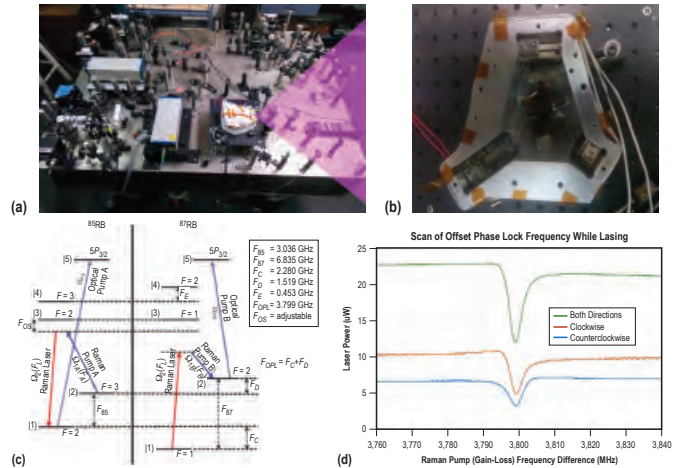

(a) The table-top AFLOGA setup. (b) Close-up view of the cavity containing the two SRLs. (c) Atomic transitions involved in realizing the SRL in each direction. (d) Individual (red and blue) and combined output of the two SRLs showing dips at the center, which produce the anomalous dispersion superluminal operation needs.

of a single SRL using DPAL gain and Raman depletion, showing an inferred enhancement in sensitivity by a factor of ~ 190 .

BENEFITS

These gyroscopes and accelerometers will have substantially improved sensitivity and reduced size, weight, and power requirements compared to conventional technology. Therefore, they will be better suited to navigate NASA space vehicles of all sorts, particularly those where size, power, and precise navigation are critical. These technologies may also foster an array of new scientific missions, such as gravitational mapping of subsurface geologic features, and enhance significantly gravitational wave detection sensitivity. Additionally, the gyroscopes, accelerometers, and sensors developed in this program will improve navigation accuracy at reduced size, weight, and power cost. They can also be used in atmospheric and terrestrial vehicles, particularly unmanned aerial vehicle navigation.

PROJECT MANAGER: David D. Smith

FUNDING ORGANIZATION: Small Business Innovative Research

Correlated Electromagnetic Levitation Actuator

OBJECTIVE: *To advance correlated permanent magnet technology over correlated electromagnets in order to exhibit the levitation and rotation behaviors a frictionless reaction wheel requires.*

PROJECT DESCRIPTION

With this project, we seek to establish the feasibility of an efficient frictionless reaction wheel, using correlated electromagnets, by levitating and rotating one above the other and using actuation to change the levitation height and rotation. Correlated permanent magnets do exist and have many useful applications, but because they are printed and permanent, they cannot be changed, controlled, or actuated. We could make significant advancement in the magnets' current applicability to technology challenges of interest if we could control the individual dipoles of correlated electromagnets electrically. The prototype we are develop-

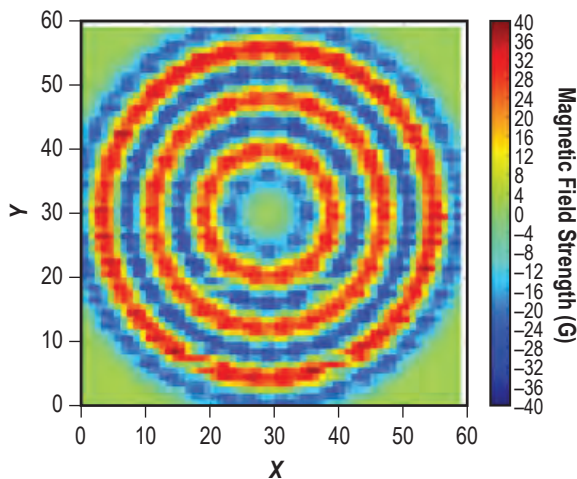

Magnetic field strength at the surface of the array.

ing demonstrates a frictionless reaction wheel to use on satellites. Additionally, Correlated Electromagnetic Levitation Actuator (CELA) aligns with the following MSFC goals: Affordable, innovative transportation architectures and technologies for low-Earth orbit (LEO) delivery of small payloads; small, affordable ISS payloads; technologies for space situational awareness and space object interactions; and small spacecraft and enabling technologies.

ACCOMPLISHMENTS

At the beginning of FY2016, we completed controller and demonstration test structure design, manufactured two prototypes, and constructed the magnetic field apparatus. During FY2016, we developed closed loop control logic modeling with the use of empirical data gathered from testing. We completed prototype characteristic testing for several new prototypes, a COMSOL model of an inductor array, and the Hover Field demonstration preparation. Partnering with MSFC internal partners, we conducted advanced manufacturing research as well.

BENEFITS

This project focuses on a single application—a frictionless reaction wheel—removing the need for ball bearings, a major failure point for reaction wheels. The demonstration of correlated magnetics also opens doors for many other applications, for instance, testable separation systems and autonomous docking.

PROJECT MANAGERS: Sarah Triana, Paul Britton

FUNDING ORGANIZATION: Center Innovation Fund



LIFE SUPPORT AND ENVIRONMENTAL MONITORING



For future crewed missions beyond low-Earth orbit and into the solar system, regular resupply of consumables and emergency or quick-return options will not be feasible. Therefore, TA 6 focuses on developing technologies that enable long-duration deep space human exploration with minimal resupply and increased independence from Earth.

Series-Bosch Oxygen Recovery for Life Support

OBJECTIVE: *To increase the maturity of a Series-Bosch system dedicated to recovering and recycling up to 100% of oxygen from the carbon dioxide astronauts exhale.*

PROJECT DESCRIPTION

Life support is critical for all manned space missions. As NASA journeys farther from Earth, resupply of human metabolic requirements, such as oxygen and water, becomes significantly more challenging. Series-Bosch (S-Bosch) technology is one option to recover and recycle oxygen for the crew. The S-Bosch takes the carbon dioxide the astronauts exhale and, in tandem with the Oxygen Generation Assembly, converts it to oxygen and solid carbon. The system provides oxygen back to the crew for respiration. The solid carbon product can be discarded or repurposed. This system is expected to recover and recycle more than 95% of the oxygen from carbon dioxide, compared to about 50% the International Space Station currently recycles.



Proteus™ Membrane subassembly for hydrogen separations in development-level housing.

ACCOMPLISHMENTS

The S-Bosch system is designed to include four subassemblies for optimum operation. The first two subassemblies are a Reverse Water-Gas Shift reactor and a Carbon Formation Reactor. Both are catalytic reactors. The other two subassemblies are membrane separation systems purchased from Membrane Technology Research. One separation system, the Polaris™, is dedicated to carbon dioxide purification and recycling, while the Proteus™ is dedicated to hydrogen purification and recycling. Prior to 2016, each of the four S-Bosch system subassemblies had been tested individually to evaluate performance.



Reverse Water-Gas Shift Reactor with band heaters and integrated thermocouples

During FY2016, the four subassemblies were combined into a single S-Bosch system and tested to demonstrate performance at a carbon dioxide processing rate equivalent to that of a single crew member. The Reverse Water-Gas Shift reactor's design was finalized in FY2016 based on a down-select between two options. A key finding during Carbon Formation Reactor testing was that flow distribution within the reactor led to undesirable carbon production variation throughout the iron catalyst material. We modified the design based on these test results and retested, confirming that performance, in fact, improved. Testing the two separation subassemblies provided essential data necessary to size the systems accurately for the next-generation hardware, designed to process carbon dioxide at a rate equivalent to four crew members.

feature

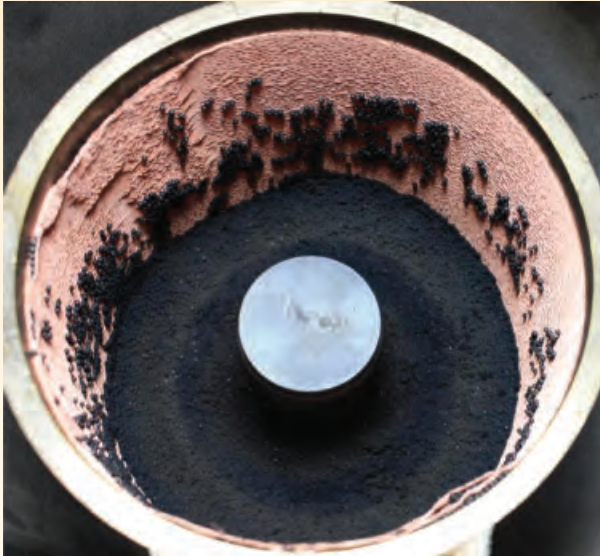

Carbon Formation Reactor, lined in copper mesh, containing solid carbon produced on iron catalyst beads.

BENEFITS

A successful S-Bosch system will provide nearly 100% oxygen recovery from the carbon dioxide astronauts exhale. Using ISS technology for a crew of four astronauts and a three-year mission, such as a Mars surface mission, we will need to resupply about 2,064 kg (4,450 lb) of oxygen from Earth to the crew. With an S-Bosch system, we will need to resupply only about 471 kg (1,036 lb). This dramatically decreases the logistics and cost of such a mission.

PROJECT MANAGER: Walter Schneider

FUNDING ORGANIZATION: Human Exploration and Operations Mission Directorate

FOR MORE INFORMATION: morgan.b.abney@nasa.gov

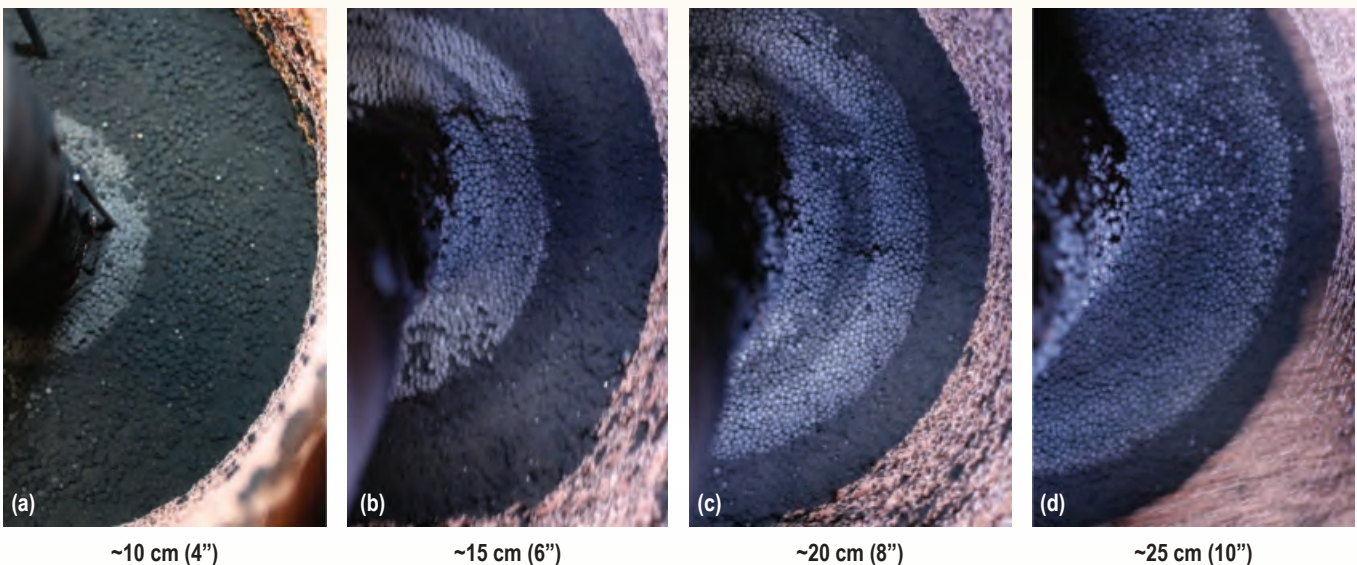

Before design modifications in the Carbon Formation Reactor, we observed a variation in carbon deposition based on distance down the length of the reactor. At ~10 cm (image (a)), carbon was fairly well distributed (black area) except near the center of the reactor (grey area). As seen in images (b)-(d), farther into the reactor, less of the catalyst bead material was fully used, as the larger grey areas showing less carbon formation demonstrate.

Hydrogen Purification for Life Support

OBJECTIVE: *To develop a hydrogen purification system capable of tolerating water, carbon monoxide, carbon dioxide, and hydrocarbons to enable advanced life support technology.*

PROJECT DESCRIPTION

The next generation of life support technology must increase resource recovery beyond that currently possible on the International Space Station (ISS). Specifically, oxygen and water recovery and recycling will be critical for future manned space missions to minimize resupply mass and logistics. The Carbon Dioxide Reduction Assembly (CRA) on ISS can recycle about 50% of the oxygen from the carbon dioxide the crew exhales. Adding a Plasma Pyrolysis Assembly (PPA) will increase that recovery to >75%. However, integrating these two systems requires purification of hydrogen, a gas necessary to operate both systems. We must purify this approach's hydrogen stream from a mixed stream containing water vapor, carbon monoxide, carbon dioxide, and hydrocarbons including methane, acetylene, ethylene, and ethane, among others. This presents a significant technical challenge due to intolerance of traditional hydrogen purification methods to one or more of the specified contaminants.

ACCOMPLISHMENTS

In FY2015, we conducted initial testing on three proposed approaches to hydrogen purification to determine feasibility of each. Three small businesses—Sustainable Innovations, LLC; Umpqua Research Company; and Hydrogen Consultants, Inc.—fabricated and delivered hardware based on the three approaches to MSFC.



Metal hydride approach – unique in its carbon monoxide and acetylene tolerance (Hydrogen Consultants, Inc.).

In FY2016, we tested two of the three pieces of hardware with a CRA and PPA to evaluate performance in expected integrated operating conditions. We will test the third piece of hardware in early FY2017 and select from the three options by the end of December 2016.

BENEFITS

The hydrogen purification system developed under this effort will provide the final piece of technology necessary to achieve a life support system capable of recovering >75% of oxygen from carbon dioxide. Additionally, this technology has the potential to advance Earth-based hydrogen purification technology, making it more robust against common contaminants.

PROJECT MANAGER: Walter Schneider

FUNDING ORGANIZATION: Advanced Exploration Systems

Plasma Pyrolysis Technology for Life Support

OBJECTIVE: *To increase the capability of state-of-the-art life support technology to achieve more than 75% recovery and recycling of oxygen from carbon dioxide that astronauts exhale.*

PROJECT DESCRIPTION

Astronauts in space presently require oxygen supplied from Earth. As the crew uses the oxygen, it is replaced by the carbon dioxide they exhale. For long-duration missions far from Earth, such as deep space or Mars missions, it is better to recycle the oxygen from carbon dioxide than to resupply it from Earth's surface. On the International Space Station (ISS), life support systems currently recover and recycle about 50% of the oxygen from carbon dioxide. Future NASA missions are targeting >75% oxygen recovery to reduce further the amount of oxygen that must be resupplied. The Plasma Pyrolysis Assembly (PPA) is one technology that NASA may add to the ISS life support system to achieve this goal. While core PPA technology is relatively mature, supporting technology must be advanced further. First, the PPA produces small quantities of solid carbon, an unwanted byproduct. This carbon is a very fine dust that must be captured or it can damage controllers and seals. Second, the PPA relies on feed streams from two other life support technologies: the Carbon Dioxide Reduction Assembly (CRA) and the Oxygen Generation Assembly (OGA). We must develop software that monitors the CRA, monitors the OGA, and manages the PPA's operation to ensure safe and efficient operation.

ACCOMPLISHMENTS

In 2016, we tested two designs for carbon capture. The first design involved a replaceable filter, and the second involved a reusable trap. The replaceable filter's benefit is that it requires no power; however, it is a consumable item that must be replaced, adding more mass and volume to the mission. The reusable trap's benefit is that it has no consumables; it can be used again and again. However, it requires considerable power to clean the trap for reuse. Testing showed both options are feasible.

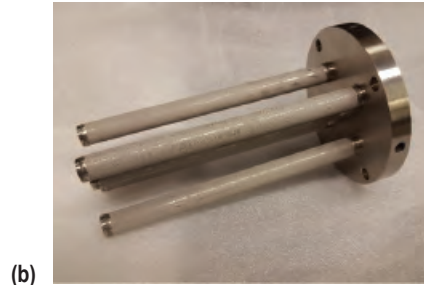
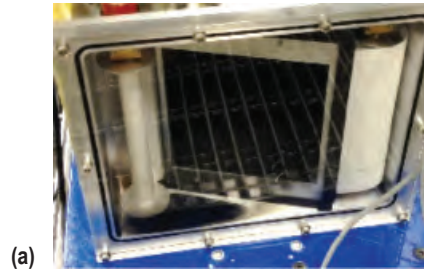

(a) Replaceable and (b) Reusable carbon capture hardware.

A final selection requires a thorough evaluation of pros and cons. Also in 2016, we started software development with an end goal of achieving fully automated operation. The software evaluates the conditions of the CRA, the OGA, and the PPA to predict failures before they cause safety hazards or losses in efficiency.

BENEFITS

Selection of a carbon trap and completion of software for PPA operation will provide essential elements of a life support technology that can achieve >75% oxygen recovery from carbon dioxide. Once combined with these elements, the PPA can be integrated on ISS to prove the performance of the technology prior to future long-duration missions.

PROJECT MANAGER: Walter Schneider

FUNDING ORGANIZATION: Advanced Exploration Systems

FOR MORE INFORMATION: morgan.b.abney@nasa.gov

Upgrades to the ISS Urine Processor Assembly

OBJECTIVE: *Modify the Urine Processor Assembly to improve reliability for future missions.*

PROJECT DESCRIPTION

Vapor compression distillation (VCD) technology is the backbone of the Urine Processor Assembly (UPA) used on the International Space Station (ISS). It was developed at Life Systems International in the 1980s. Though the VCD technology has operated well on ISS, the UPA engineering team believes that optimizing the system operation can improve performance. To improve the overall understanding of the system operation, we completed a parametric test to evaluate the VCD's multiple operational parameters. These parameters include the system pressures and temperatures, motor currents, production rate, and distillate conductivity and quality.

ACCOMPLISHMENTS

The following points describe a summary of findings from the evaluation of parametric test data and correlation of the VCD, Pressure Control and Pump Assembly (PCPA), and Fluids Control and Pump Assembly (FCPA) models:

- 1) Increasing the distillation assembly (DA) motor speed for synchronous changes in compressor and centrifuge rotational speeds provided the single biggest improvement in production rate for all enhancements considered in the parametric test program.
- 2) Changing the stationary bowl heater set point from 130 °F to 110 °F had a significant impact on power consumption with reductions up to 50%. The unit operated without incident through the heater set point changes; one caveat is that we did not quantify any accumulation of water in the stationary bowl volume through the test.
- 3) As expected, PCPA enhancements for low-temperature coolant and thermal conditioning of the purge flow from the DA condenser provided increases in pumping performance, as indicated from model predictions. We did not test increasing the PCPA pumping rate, but it could be predicted as well using the detailed PCPA model.

Over the UPA's life on ISS, FCPA operational life had been drastically reduced compared to the originally

predicted lifespan and end-of-life failure of peristaltic tube wear-out, mostly attributable to failures with the drive train. To increase FCPA life and reliability, we implemented and tested a new drivetrain at MSFC. This new design is the planetary gear drivetrain, which requires less precision during assembly and operation to maintain functionality. The first FCPA implementing the planetary gear design was installed on ISS in October 2015. As of March 30, 2016, the new gear design had operated for 593 hours with nominal performance and lower current drawn than the previous design.

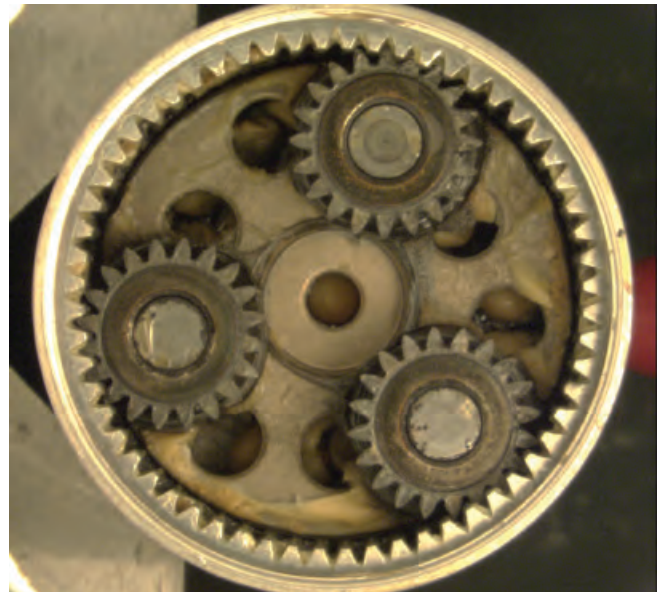

FCPA planetary gear drive.

BENEFITS

The results of the parametric test data collected and analyzed at MSFC have identified methods of improving the operational settings for the current UPA. Not only will these improvements result in increased efficiency and decreased replacement part supply, but they will also continue to improve the technologies required for future long-duration missions.

PROJECT MANAGERS: Walter Schneider

FUNDING ORGANIZATION: Advanced Exploration Systems

FOR MORE INFORMATION: donald.l.carter@nasa.gov

Upgrades to the ISS Water Processor Assembly

OBJECTIVE: *Modify the Water Processor Assembly to improve reliability and/or decrease resupply mass for future missions.*

PROJECT DESCRIPTION

NASA is developing Water Processor Assembly (WPA) modifications to either reduce resupply mass or improve system reliability. The three primary developments we are pursuing are extended life of the multifiltration (MF) Beds, reverse osmosis (RO) implementation, and evaluating various thermal catalysts.

ACCOMPLISHMENTS

MF Beds use adsorption and ion exchange media to remove the majority of dissolved contaminants from the WPA wastewater stream. Ideally, once the first MF Bed is expended (as indicated by conductivity breakthrough), the second MF Bed is moved into the first position and a fresh MF Bed placed in the now vacant second location. According to their current design, only volatile organic compounds pass through the Bed to the downstream catalytic reactor where, ideally, they are oxidized to primarily two compounds: acetate and/or bicarbonate. The MF Beds remove the compounds, which make up a substantial portion of the wastewater ionic load; therefore, we made modifications to let acetate and bicarbonate pass through the MF Beds and enter the catalytic reactor. This may extend the MF Bed's life, reducing upmass. Initial testing at MSFC with a full-scale development catalytic reactor demonstrated that typical bicarbonate and acetate levels in a saturated MF Bed effluent were within the reactor's oxidation capacity.



WPA MF Beds (1-3 first Bed, 4-6 second Bed).

We are initiating RO development for integration into the ISS WPA. We completed limited research activity in FY2016 at Ames Research Center. Testing at MSFC to identify the operating regime for the RO module is scheduled for FY2017. It will include the number of modules required and whether meeting the desired percent recovery (95%) requires reprocessing. We also planned extensive tests to evaluate various thermal catalysts, analyzing their stability and activity.

BENEFITS

The WPA MF Beds comprise a significant resupply mass, required to support system operation since each ISS MF Bed has a mass of 110 lb. This resupply penalty is currently exacerbated because dimethylsilanediol (DMSD) emerged in the WPA wastewater stream, which necessitates replacing both MF Beds more frequently than their nominal design lifetime. There is an ongoing design effort to address the removal of DMSD from the cabin air stream, thus preventing contamination of the condensing heat exchanger, one of the WPA's primary sources of water. Theoretically, assuming successful implementation of an engineering solution to control DMSD contamination, we can extend the MF Beds' lifetime. Reverse osmosis is another possibly viable technology for the WPA. Overall improvements in RO technology suggest that it is a competitive replacement for the current MF process, with less resupply mass than the MF technology requires.

PROJECT MANAGER: Walter Schneider

FUNDING ORGANIZATION: Advanced Exploration Systems

FOR MORE INFORMATION: donald.l.carter@nasa.gov

Life Support Systems

OBJECTIVE: *To advance the state-of-the-art life support systems on the International Space Station (ISS) and develop technologies to close life support system gaps needed for space exploration.*

PROJECT DESCRIPTION

The development of reliable, energy-efficient, and low-mass spacecraft systems to provide environmental control and life support is critical to achieving long-duration human missions beyond low-Earth orbit. The Human Exploration Framework Team identified high-reliability life support systems as a required technology for destinations beyond cis-lunar space. For life support, this means that there is the need for technological flexibility to permit safe, affordable, and sustainable human space exploration. A strategy to achieve this necessary flexibility is to employ a common core architecture, with modularity as the key building block of human spacecraft and space habitat systems at the lowest functional level possible. Doing so can provide tangible nonrecurring and recurring cost reduction by minimizing designs, testing, and evaluation aimed at a specific destination. The Life Support System (LSS) project aims to advance environmental control and life support system technologies within this modular framework.

ACCOMPLISHMENTS

MSFC accomplishments included selecting a few screened sorbents and desiccants from a large initial number of candidates so we could make a final selection of the best materials to replace those being used on the ISS. We tested technologies for providing high-pressure and high-purity oxygen. A system that provides high-pressure oxygen eliminates the need to stow high-pressure oxygen tanks on the spacecraft. Testing of plasma pyrolysis and Bosch technologies to recover more oxygen continued. Other Centers' accomplishments on the project included selection of brine technologies to recover more water from urine. NASA initiated a contract with Paragon to develop a brine processor, with expected delivery in 2018. An aerosol sampler flight demonstration was delivered for expected

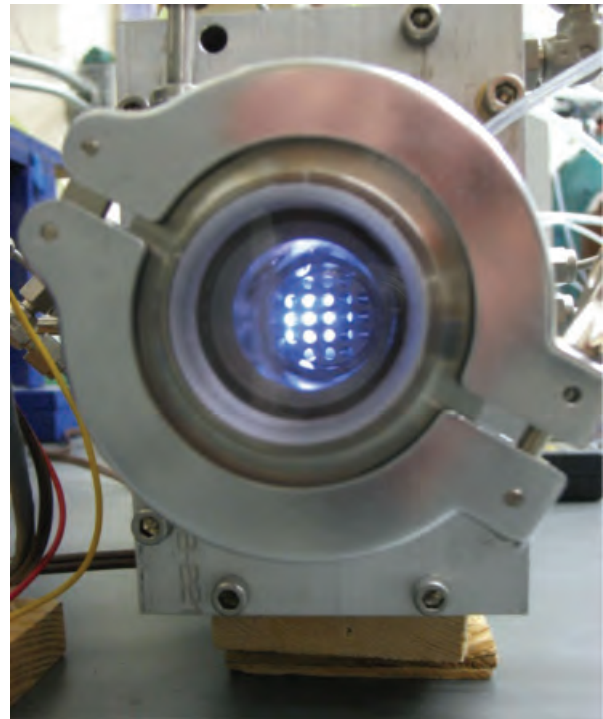

Plasma Pyrolysis Assembly (PPA) recovers hydrogen from the methane the Carbon Dioxide Reduction Assembly (CRA)/Sabatier produces, helping recover oxygen from carbon dioxide.

launch to the ISS in October 2016. This hardware will fly on the ISS to help understand air particulates in spacecraft. The Spacecraft Atmosphere Monitor completed a Systems Design Review. This hardware will allow real-time sampling of the spacecraft atmosphere without the need to return samples to Earth for analysis.

BENEFITS

Because the ISS resides in a relatively close orbit around the Earth, it can depend on a stream of supplied consumables to maintain its operations. Technologies the LSS project is developing will allow deep space exploration with significantly reduced need for consumable resupplies.

PROJECT MANAGERS: Walter Schneider, Project Manager, Marshall Space Flight Center; Sarah Shull, Deputy Project Manager, Johnson Space Center

FUNDING ORGANIZATION: Advanced Exploration Systems

Carbon Dioxide Removal and Management

OBJECTIVE: *Develop a highly reliable Carbon Dioxide Removal and Management System that can support four crewmembers with reduced cabin CO₂ levels, using minimal mass, power, and volume.*

PROJECT DESCRIPTION

In any manned space mission, technology must be available to remove the carbon dioxide exhaled by the crew during normal respiration. On the International Space Station (ISS), the Carbon Dioxide Removal Assembly provides this service. During the last 16 years of operation, several key areas for improvement have been identified for implementation into the next-generation carbon dioxide removal and management system. In FY2016, carbon dioxide removal and air drying efforts focused on improving the current state-of-the-art systems that use fixed beds of sorbent pellets. Seeking more robust pelletized sorbents, the project evaluates structured and alternate sorbents, and examines alternate bed configurations to improve system efficiency and reliability. These development efforts combine sorbent screening and characterization, testing of subscale and full-scale systems, and multi-physics computer simulations. These simulations evaluate candidate approaches, select the best performing options, and optimize the selected approach's configuration. We will implement the subsystem we select as a technology demonstration on the ISS to confirm extended operation in the microgravity environment.

ACCOMPLISHMENTS

During FY2016, we made significant gains in many areas, including the fabrication and checkout of an exploration system full-scale test stand, ranking sorbent candidates, and validating a multi-physics simulation (results shown below) now being used for simulation-based design.

BENEFITS

One of NASA's long-term goals is crewed Mars missions, first to the vicinity of the planet, and then to the Martian surface. These missions present new challenges for all aspects of spacecraft design compared to the ISS, as resupply is unavailable in the transit phase, and early return is not possible. Additionally, we must minimize mass, power, and volume for all phases so that we reduce propulsion needs. The ISS has proven to be a helpful testbed, increasing our understanding of the combined physiological impacts of microgravity and CO₂ at higher than Earth levels. The elevated risk associated with exposure to increased CO₂ levels requires lower levels for Mars missions than we achieved on ISS. This project focuses on developing enhanced carbon dioxide removal systems to meet these requirements for future crewed Mars missions.

PROJECT MANAGER: Walter Schneider

FUNDING ORGANIZATIONS: Advanced Exploration Systems; International Space Station; Space Technology Mission Directorate, Small Spacecraft Technology Program

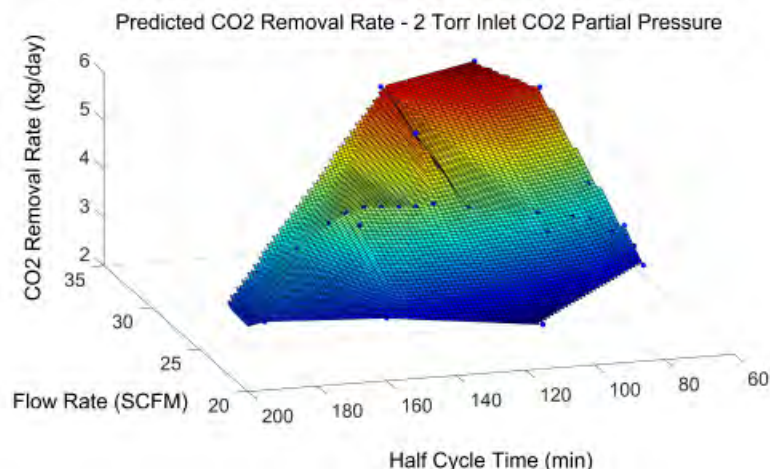

Results from a multi-physics simulation aimed at evaluating candidate CO₂ removal approaches.

Trace Contaminant and Particulate Matter Control

OBJECTIVE: *Characterize and select the best adsorbent media, catalysts, filtration media, and equipment designs for trace contaminant and particulate matter control for cabin air purification systems.*

PROJECT DESCRIPTION

Trace contaminant (TC) and particulate matter (PM) control is a vital life support systems (LSS) component necessary to maintain crew health and safety on future crewed exploration missions. Human metabolism, crew housekeeping activities, and research activities introduce TCs into the cabin environment, while most PM is from the crew. Particulate Matter includes fabric lint, skin fragments, hair, food debris, and paper/plastic debris. During surface exploration missions, surface dust intrusion during extravehicular activities (EVA) usually adds to the basic PM load challenge and may impact the TC load. Compounding the challenge, in the low- and microgravity conditions of future space exploration missions, no particle settling occurs, so PM introduced into the cabin remains suspended in its atmosphere. These challenges require a robust, active TC and PM removal and disposal capability to keep cabin conditions within the NASA standards that ensure crew health and safety, and assure mission success. High-efficiency adsorbent media, oxidation catalysts, and filtration media provide TC and PM functions. Building on TC and PM control knowledge gained on the International Space Station, the AES LSS project's TC and PM control technical area is characterizing and selecting those materials that possess the working capacities, physical properties, and performance needed to extend the journey farther into the solar system.

ACCOMPLISHMENTS

Trace contaminant and PM control developmental efforts in FY2016 characterized adsorbents, catalysts, and processes for volatile organic compounds, ammonia, carbon monoxide, and formaldehyde control. We developed a TC control architecture and tested adsor-

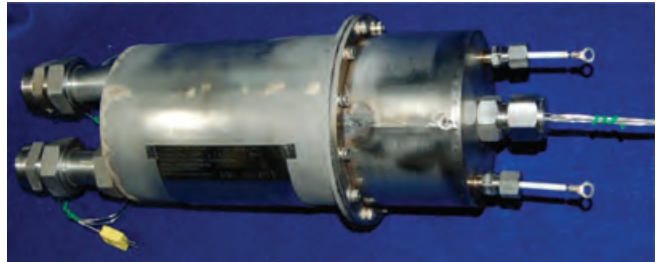

Advanced TC control catalytic oxidizer-heat recuperator assembly.

bent bed and catalytic oxidation components at full scale, and we developed functional requirements and a multi-stage technical solution for PM control for future missions. We tested PM technical architecture components at full scale, and documented design considerations for TC and PM control to present at technical conferences.

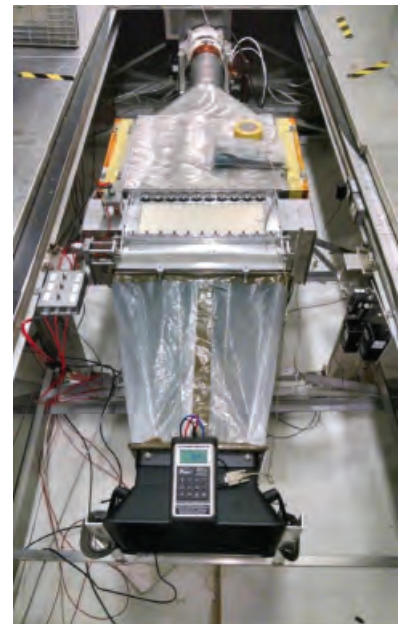

Filtration assembly for exploration being tested in a ventilation system.

BENEFITS

Trace contaminant and PM control are key to crewed spacecraft cabin ventilation and LSS architectures. Trace contaminant and PM contamination are challenges to atmospheric quality and to protecting sensitive equipment. Trace contaminant and PM technologies employed on crewed spacecraft apply also to the automotive, commercial aircraft, and indoor air quality control industries. Anywhere people are in confined spaces or energy-efficient buildings, the TC and PM contamination health risks may lead to chronic health issues. Technical approaches toward ensuring a healthy, high-performing crew can adapt to improving health at home and elsewhere.

PROJECT MANAGER: Walter Schneider

FUNDING ORGANIZATION: Advanced Exploration Systems

Wireless Temperature Sensing in the Urine Processor Assembly

OBJECTIVE: *Use wireless sensors to monitor conditions inside parts of the Urine Processor Assembly (UPA) that were previously inaccessible.*

PROJECT DESCRIPTION

The unique characteristics of wireless sensors let us use them in circumstances where a conventional wired sensor may not be suited to the task.

Some of these features are: compact size; the capacity for placement on moving or rotating machinery, where wires would prevent free movement; the ability to encapsulate the sensor, protecting it from harsh environments; and the ability to power the sensor externally through a medium such as radio waves, so the sensor can function as a passive device with no risk of running out of energy, with technologies such as Radio Frequency Identification (RFID).



Wireless sensor (black) molded onto the wall of the Distillation Assembly.

ACCOMPLISHMENTS

RFID-based wireless temperature sensors were incorporated into the ground test version of the UPA, a key life support technology used to recover water on the International Space Station. The sensors were installed in the Distillation Assembly (DA), a sealed, rotating tank containing harsh acids. The sensors overcame the challenges of this environment because of the features described. We positioned sensors in the DA's evaporator and condenser regions so that we could monitor the phase change process. The wireless sensor-equipped

DA successfully collected data during studies performed to optimize and improve on the UPA. The sensor system has provided the first-ever data on temperatures inside an operating DA, including real-time monitoring of operating conditions, and measurement of the temperature of boiling surfaces. Previously, these locations were considered impossible to monitor. The sensor integration was a multi-year effort that concluded in FY2016 with the acquisition and analysis of test data.

BENEFITS

The new wireless-based measurements of surface temperatures in boiling and condensing regions have allowed us to assess the UPA's efficiency (specifically, the phase change process), and they have revealed an avenue for improvement. The study also demonstrated that wireless sensors can operate in a challenging environment with confined spaces, fast rotation, harsh chemicals, and radio-reflective materials, which expands the range of potential uses for such sensors. For future UPA flight units, the additional monitoring and real-time feedback of wireless sensors could allow for more sophisticated and adaptive operation of systems in-flight.

PROGRAM MANAGER: Chris Evans

FUNDING ORGANIZATIONS: Human Exploration and Operations Mission Directorate, International Space Station

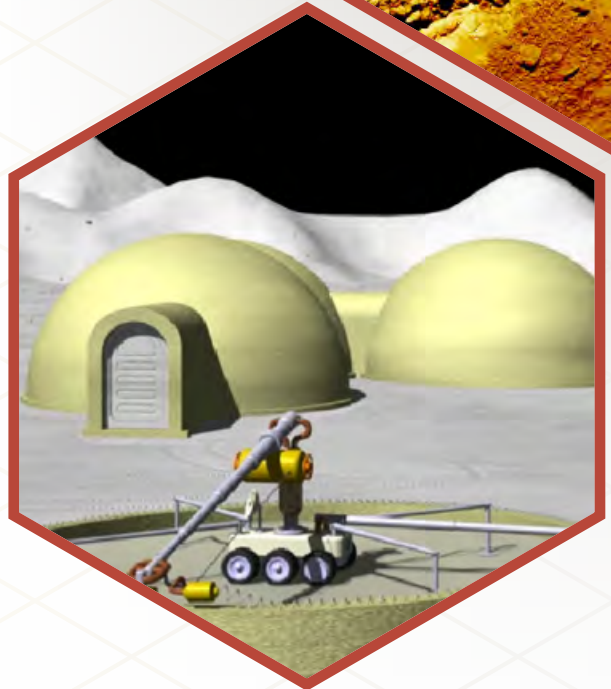
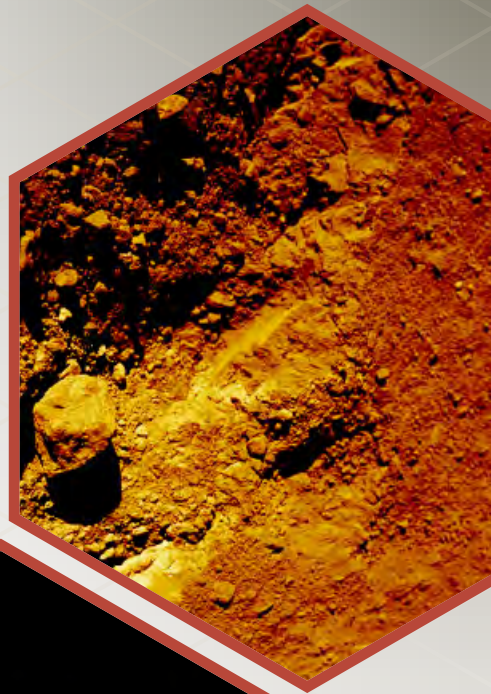



HUMAN EXPLORATION DESTINATION SYSTEMS

The research described in this section relates to sustaining human presence in space, which will require existing systems and vehicles to become more independent, incorporate intelligent autonomous operations, and take advantage of the local resources. Advances must be made in finding, extracting, and processing

in situ resources. The reliability of all mission systems—especially habitation components—must be improved, and all systems must be easier to maintain or repair.



Additive Construction with Mobile Emplacement

OBJECTIVE: *Develop technologies to produce materials necessary for construction on extraterrestrial surfaces, coupled with technologies for the actual printing of habitats and other structures.*

PROJECT DESCRIPTION

Although the ability to 3D print structures like houses, garages, roads, and even landing pads sounds like futuristic science fiction, NASA and the U.S. Army Corps of Engineers (USACE) are advancing this technology—known as additive construction—today. Marshall Space Flight Center (MSFC) and Kennedy Space Center (KSC) are co-leading NASA’s Additive Construction with Mobile Emplacement (ACME) project and supporting USACE’s Automated Construction of Expeditionary Structures (ACES) project.

ACCOMPLISHMENTS

ACME focuses on developing technologies required to sort and process excavated materials into a feedstock, advance planetary construction material properties, and optimize these material compositions to use with the additive construction process. ACME consists of subsystems that process, mix, and continuously feed a cement and planetary simulant mixture through a nozzle mounted on a mobility system, such as, a gantry. ACME has demonstrated successfully that we can build both straight and curved walls using Martian simulant, using a cement that astronauts can produce from feedstock on the surface of Mars. We have upgraded the ACME system many times this year, including a continuous feedstock delivery system and an advanced nozzle from Contour Crafting Corporation that, when combined with improved software, can pause operations to build windows and doors. USACE is integrating many of ACME’s techniques, hardware, and expertise directly into ACES to demonstrate the ability to construct structures critical to Army operations, such as barracks, Hesco barriers, and guard shacks.

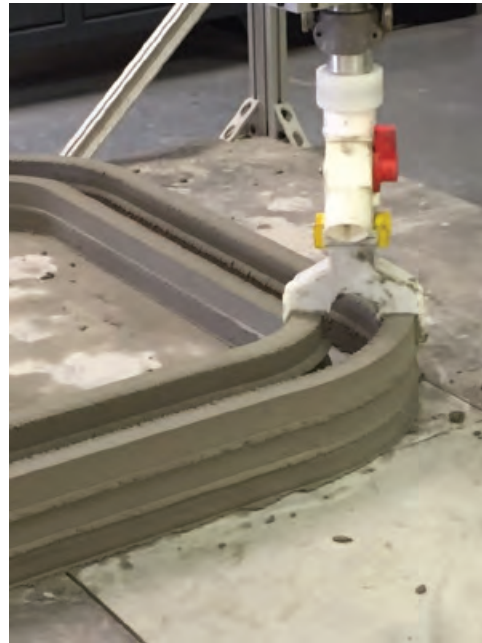

Multi-layer wall built with a multi-outlet nozzle at MSFC.

BENEFITS

ACME’s vision is to advance science and human exploration by using in situ resources that feed additive construction techniques that can build needed infrastructure efficiently. Using in situ resources will reduce the mass of materials that we must transport to the space destination by a factor of 2,000:1, clearly a cost-saving opportunity. We can use additive construction and in situ materials to build both terrestrial and extraterrestrial structures, which reduces the time and cost required to transport materials, and also reduces waste as compared to traditional construction techniques. The ACME and ACES projects’ success has caught the construction industry’s eye, with a proposed partnership from an industry leader.

PROGRAM MANAGER: Niki Werkheiser

FUNDING ORGANIZATIONS: Game Changing Development Program, U.S. Army Corps of Engineers

Ionic Liquid Metals and Oxygen Extraction in Microgravity — A Prelude to Asteroid Mining

OBJECTIVE: *To design a hardware prototype for an ISS experiment demonstrating electroplating of metals from meteoritic sources.*

PROJECT DESCRIPTION

Exploration within the solar system and beyond will require making use of the resources that are at the destination site, or “living off the Land” as America’s first pioneers did. Task-specific ionic liquids can be used in a variety of ways to enable NASA’s exploration missions. One of these uses is for the extraction of metals and oxygen from lunar, planetary, or asteroid soils, using an environmentally safe ionic liquid. The oxygen in the soil reacts with the hydrogen in the ionic liquid acid to make water, and the metals are dissolved, forming soluble salts. The water is then electrolyzed to form oxygen and hydrogen. The oxygen can be used for life support or propellant, and in a further step, the hydrogen is used to regenerate the ionic liquid to dissolve more soil and to also plate out the metals and use them for manufacturing spare parts. Mining asteroids for their resources will require methods that will work under very low gravity conditions, so it is necessary to test whether it is possible to perform the same methods used on Earth within the low-gravity environment of the International Space Station. This project is to develop test hardware for this purpose.

ACCOMPLISHMENTS

A general design for the electrolysis cell had been envisioned, but engineering expertise was required to add more detail and then manufacture a three-dimensional replica. Having this gives us better insight into future tasks and what kinds of materials would be desirable to use in a flight experiment. A variety of materials have been tested for compatibility with the chemicals and conditions that will be involved with a flight. Next steps are to further refine the model and to build a working prototype for laboratory testing.

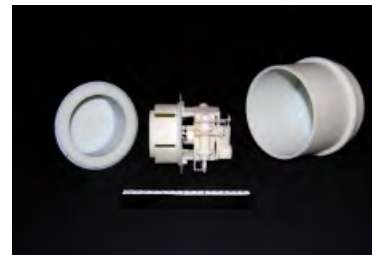

Detailed schematic for electrolysis cell.

BENEFITS

The cost to launch all required supplies for life support and further manned travel to worlds beyond Earth’s moon would be prohibitive without using resources available along the way and at the destination. Asteroids, our moon, and other planets and moons can provide a wealth of resources, but we need to learn how to efficiently extract them and process them into necessary materials. Ionic liquids are a class of organic salts that are liquid at room temperature and can be made task-specific to perform the work that nearly any conventional chemical can, but without the vapors and fumes that are often associated with chemical reactions. Because they have no vapor pressure, they work in the high vacuum of space without evaporating, and they also work at much lower temperatures, thus saving energy. Moreover, for this project, the ionic liquids are regenerable and can be reused many times, thus cutting launch costs. The processes used in this project can also be used on Earth, for example, to mine for rare, costly metals available in small quantities and for recycling costly metals after use.

PROGRAM MANAGER: Laurel Karr

FUNDING ORGANIZATION: Technology Investment Program

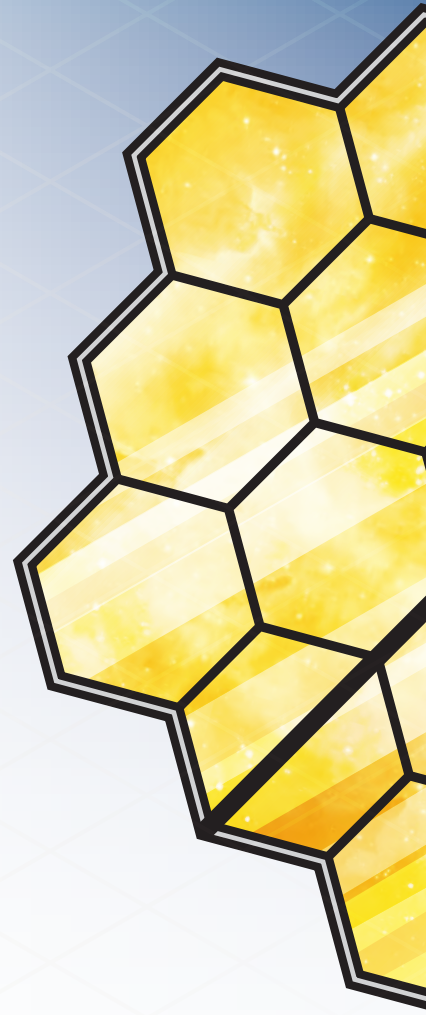



SCIENCE INSTRUMENTS

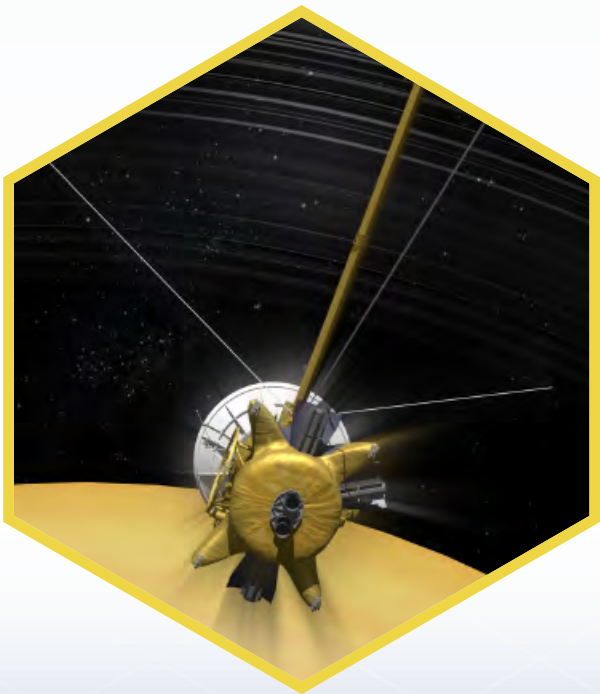

NASA's pursuit of science and exploration relies on improving and developing new remote sensing instruments and sensors, observatories, and sensor technologies. These technologies are necessary to collect and process scientific data,

either to answer compelling science questions as old as humankind (for example, how did our planetary system form and evolve?) or to provide crucial knowledge to enable robotic missions such as remote surveys of Martian geology to identify optimal landing sites.

Advanced UVOIR Mirror Technology Development for Very Large Space Telescopes

OBJECTIVE: *Mature technology to enable 4-m or larger UVOIR space telescope primary mirrors.*

PROJECT DESCRIPTION

The Advanced Mirror Technology Development (AMTD) project is in Phase 2 of a multiyear effort to mature towards Technology Readiness Level-6 (TRL-6) by 2018 critical technologies required to enable 4-m or larger ultraviolet, optical, and infrared (UVOIR) space telescope primary mirror assemblies for general astrophysics and ultra-high contrast observations of exoplanets.

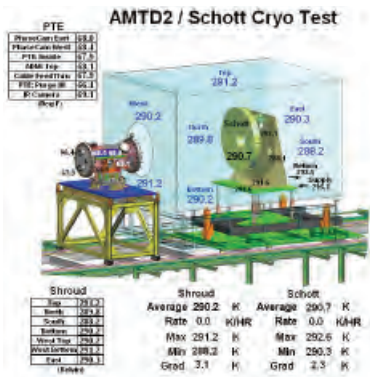

Schematic of test configuration.

ACCOMPLISHMENTS

AMTD successfully low-temperature fused a 1.5-m-diameter ULE[®] mirror that is a one-third scale model of a 4-m mirror and characterized the cryogenic performance of a 1.2-m Extreme-Lightweight Zerodur[®] mirror. AMTD used developed integrated modeling tools to evaluate primary mirror systems for a potential habitable exoplanet mission and analyzed the interaction between optical telescope wavefront stability and coronagraph contrast leakage. AMTD provided four undergraduate internships for mentoring the next generation of scientists and engineers. Finally, AMTD results were presented at Mirror Tech Days 2015 and published at the 2016 SPIE Astronomy Conference.

BENEFITS

AMTD's demonstrated deep-core manufacturing method enables 4-m class mirrors with 20%-30% lower cost and risk. The developed design tools increase speed, resulting in a reduced cost for trade studies and enable better definition of system and component engineering specifications.

PROJECT MANAGERS: H. Philip Stahl, Michael Effinger

FUNDING ORGANIZATION: Science Mission Directorate

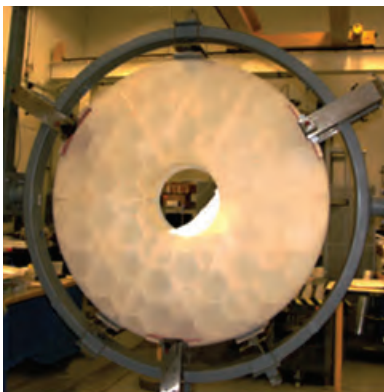

1.5-m ULE mirror at Harris.

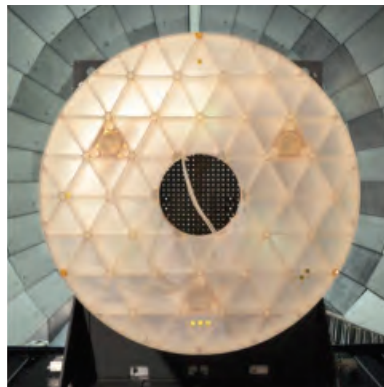

1.2-m Zerodur mirror.

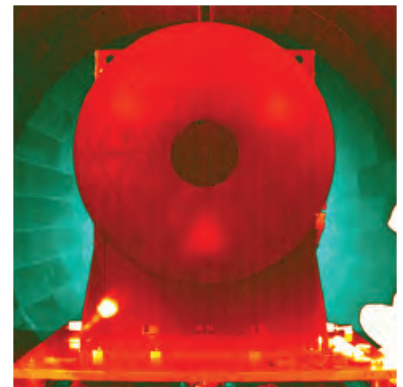

Thermal image of 1.2-m Zerodur in the X-ray and Cryogenic Facility.

Mars Ascent Vehicle

OBJECTIVE: *Mature technologies for the Mars Ascent Vehicle to enable a robotic sample return.*

PROJECT DESCRIPTION

The MSFC scope of work for the Mars Ascent Vehicle (MAV) has continued to evolve. In 2016, the focus was to perform a design and analysis cycle (DAC) on the second stage motor of a two-stage solid motor MAV design, assess the performance of a spin-stabilized second stage, complete thermal cycling testing of a hybrid fuel, support the hybrid MAV system design, and initiate thermal and launch support system concept development.

Second Stage Solid Motor MAV Design

We have put significant effort into a two-stage solid motor MAV design. However, the emphasis has been on the first motor as the likely driving element in performance. To provide a thorough assessment of the overall vehicle performance, we performed a DAC of the second stage to establish performance metrics and identify any technology challenges.

Second Stage Spin Stabilization Analysis

A potential opportunity to reduce mass on the two-stage solid motor MAV is to use a spinning unguided second stage. A spun upper stage has the potential to reduce second stage mass by eliminating the thrust vector control system, but requires some mass for the spin and de-spin. We must consider sample mass uncertainty. MSFC performed analyses to determine required spin rates, assess sensitivity to sample center of gravity uncertainty, and calculate mass and orbit insertion impacts.



Artist rendering of a potential launch of the MAV system.

Hybrid Fuel Thermal Cycle Testing

The thermal environment on the surface of Mars is challenging for fuel options. MSFC tested hybrid parrying fuel samples to simulate an environment JPL provided to represent what the MAV will experience during seasonal and diurnal cycles.

Hybrid MAV Design Support

The MAV hybrid solution is pushing the performance for a MAV system. MSFC is supporting the hybrid system design with a preliminary case design, ballistics analyses, detailed nozzle design, and the design and performance of liquid injection thrust vector control.

ACCOMPLISHMENTS

MSFC made significant progress towards the objectives of the MAV project in FY2016. MSFC completed the two-stage solid MAV second stage motor DAC; established performance metrics, and confirmed no unique second stage motor technology challenges. MSFC also completed second stage spin stabilization analysis, recommending a guided second stage. The test area completed thermal cycle paraffin hybrid fuel testing, and a design of the baseline propulsion system was matured.

BENEFITS

The remainder of 2016 and beyond will focus on the hybrid based MAV design. The hybrid propulsion system's benefits include a lower storage temperature requirement for the fuel, significantly reducing the lander resources required to condition the MAV prior to launch. Also, unlike a solid-based system, the restart capability allows for a simplified single-stage-to-orbit solution, reducing overall complexity and simplifying terrestrial demonstration significantly.

PROJECT MANAGERS: John Dankanich; Robert Shotwell, Jet Propulsion Laboratory

FUNDING ORGANIZATION: Science Mission Directorate

Low-Noise Cameras for Suborbital Observations

OBJECTIVE: *Develop a low-noise camera for use on suborbital flight instruments.*

PROJECT DESCRIPTION

NASA uses suborbital platforms, such as sounding rockets, balloons, and CubeSats, not only to develop new technologies and test instrument concepts, but also to train the next generation of scientists. In solar and heliospheric physics, these activities are funded through the Low-Cost Access to Space (LCAS) program, part of the Heliophysics Technology and Instrument Development for Science (H-TIDeS) program. These efforts are low-cost, high-risk instrument development projects. The NASA Marshall Space Flight Center (MSFC) Solar Instrumentation group has developed, or is currently developing, several instruments to be flown on sounding rockets to create images of different levels of the solar atmosphere.

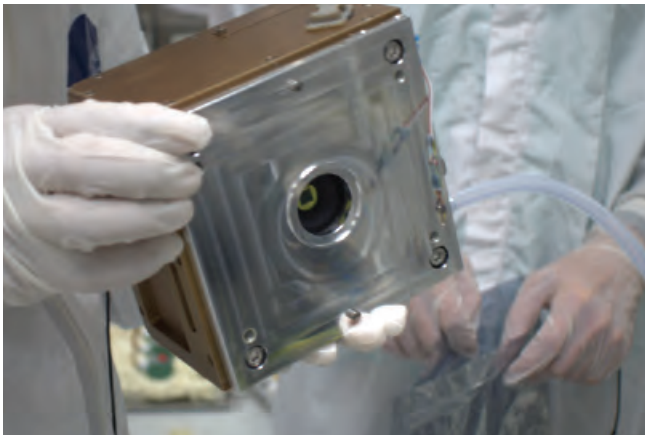

Low-noise camera developed for the CLASP instrument.

ACCOMPLISHMENTS

During the development of the Chromospheric Lyman-Alpha SpectroPolarimeter (CLASP) instrument, MSFC scientists and engineers developed a low-noise camera suitable for suborbital flights. The original camera, designed for a 512×512 e2v CCD, included two custom designed electronics boards, a cold-block to cool the CCD, and a metal chassis. The camera flew successfully on CLASP on September 3, 2015, and achieved a noise level of seven electrons (compared to >100 electrons noise from previous camera sys-

tems used in MSFC sounding rocket instruments). We have expanded the original design for a 2k × 2k CCD. This larger format camera flew in the High-resolution Coronal Imager (Hi-C) in July 2016 and will fly on the Marshall Grazing Incidence X-ray Spectrograph (MaGIXS) and Extreme Ultraviolet Snapshot Imaging Spectrograph (ESIS) in 2018-2019.

BENEFITS

These low-cost, low-noise cameras can be made available for other instrument teams requiring a similar solution. Additionally, we can expand the technology now to develop low-cost, low-noise cameras for orbital missions.

PROGRAM MANAGER: Amy Winebarger

FUNDING ORGANIZATION: Science Mission Directorate



MODELING AND INFORMATION TECHNOLOGY

The overarching goal of this technology area is to develop computing, modeling and simulation, and information technologies that are the basis of new solution paradigms across the breadth of NASA's missions. TA 11 focuses

on enabling the NASA mission by developing modeling, simulation, information technology, and processing technologies that ultimately increase NASA's understanding and mastery of the physical world.

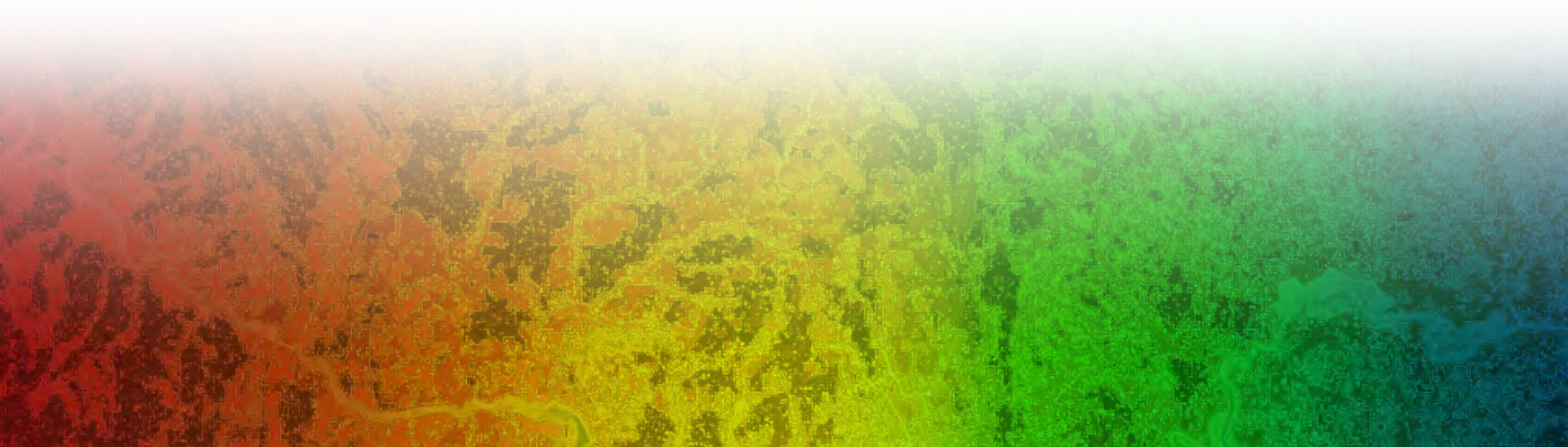

Streamlining Access to NASA Data to Address Agricultural and Water Availability Issues

OBJECTIVE: *Develop a tool that allows multiple stakeholders to visualize environmental data for regions in Africa and Asia in order to improve agriculture and water availability in those regions.*

SERVIR, based at Marshall Space Flight Center with hubs in Africa, Southeast Asia, and the Hindu Kush-Himalaya region, developed the ClimateSERV tool in 2016. This tool helps development practitioners, scientists/researchers, and government decision makers visualize and download historical rainfall data, vegeta-

tion condition data, and 180-day rainfall and temperature forecasts to improve understanding of, and make improved decisions for, issues related to agriculture and water availability.

In SERVIR hub regions, where long-term ground observations of rainfall are sparse, there is a critical need for satellite and model-derived rainfall data for predicting droughts, estimating crop yields, and more. Decision makers need a way to assess accurately how severe a drought will be, how it compares to past droughts, and its potential effect on crop yields. Such assessments require accurate rainfall variation estimations in space and time. It is important to place an evolving dryer-than-normal season into historical context to analyze the rainfall deficits' severity. Until now, such analyses used rainfall data from ground observations at specific points on the Earth's surface. However, those data fail to show the region-wide variability that reveals comprehensive rainfall patterns. To complicate matters further, developing countries' internet connectivity challenges make accessing large volumes of satellite imagery problematic.



KIMBERLY FLOWERS/USAID

feature

SERVIR developed a tool to distribute NASA satellite-derived data on rainfall and vegetation health, as well as spatially downscaled seasonal (180-day) forecasts based on North American Multi-model Ensembles, and created an easy-to-use, web-based system called ClimateSERV to view, analyze, and download the data and forecasts. Using ClimateSERV, development practitioners, scientists/researchers, and government decision makers can analyze historical rainfall for the past 30 years readily, and then compare it with the best available forecasts for the next 180 days for their defined area of interest to improve understanding of, and make improved decisions for, issues related to agriculture and water availability. For example, the Kenya Meteorological Department and Intergovernmental Authority on Development Climate Prediction and Application Center use the system to access the forecasts and support their seasonal planning.



REGIONAL CENTRE FOR MAPPING OF RESOURCES FOR DEVELOPMENT (RCMRD)

ClimateSERV helps decision makers in the developing world, where bandwidths are low, to access and analyze large Earth observation datasets. With ClimateSERV, these decision makers can assess and monitor large-scale rainfall patterns, analyze how changing climate may affect those patterns, determine drought likelihood, and infer crop condition.



USGS, U.S. GEOLOGICAL SURVEY, PUBLIC DOMAIN

PROGRAM MANAGER: Dauna Coulter

FUNDING ORGANIZATION: Science Mission Directorate

Cloud-Based App Design

OBJECTIVE: *AVAIL, an imagery site designed to bring all the best NASA imagery together in one place, was designed and built using cloud technologies. It's the first NASA web app designed to live in the cloud, rather than based on approaches that are more traditional.*

PROJECT DESCRIPTION

The AVAIL web app is intended to bring together the best of NASA's public imagery in a single, searchable place. The site includes higher resolution versions of imagery than are typically available for download online, and uses NASA identification numbers so that those who need even higher quality versions can find them more quickly. The site was designed with adaptive design to serve the wide array of devices that will access the app, and used state-of-the-art techniques to take advantage of modern cloud hosting services and content delivery networks.

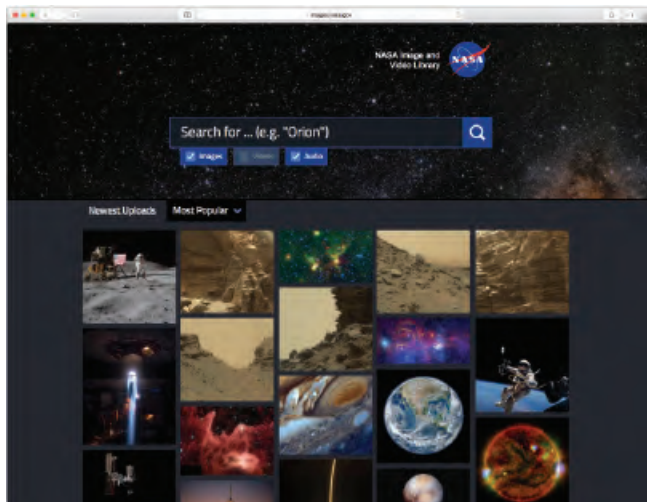

Screenshot of the home interface of the AVAIL web application.

ACCOMPLISHMENTS

Other NASA sites use the concepts of adaptive design, content delivery networks, and cloud hosting, but this is the first NASA site designed with cloud technologies in mind. The site is expandable in capability and in the size of the collection. As the audience grows, the site can grow to meet demand.

Launched in the summer of 2016, the site lets users search the collection of still imagery previously distributed in various galleries across the Agency. By the end of the year, we will have not only video imagery support, but also better support for audio files available.

BENEFITS

The site provides a key resource to disseminate the beautiful images NASA probes, instruments, and astronauts take, because it brings NASA imagery together in a single place rather than spread across numerous different sites where it is difficult to find. Modern cloud technology offers a unique capability; the app can grow as the collection and the audience grow, supported and available all over the world at reasonable cost.

PROJECT MANAGER: Rodney Grubbs

FUNDING ORGANIZATION: Advanced Exploration Systems

Dengue Forecasting Project

OBJECTIVE: To develop a forecasting system to predict risk of the mosquito presence that is the vector for the Dengue, Chikungunya, and Zika viruses.

PROJECT DESCRIPTION

The dengue (DENV), Chikungunya (CHIKV), and Zika (ZIKAV) viruses are serious public health concerns in the Caribbean and southern U.S. ZIKAV has become a particularly important public health issue because of its connection with serious birth defects. The *Aedes aegypti* mosquito transmits these viruses to humans. This study's objective is to incorporate weather forecasts and reported disease case data into a dynamic mosquito population and virus transmission model to create a system that can forecast disease case numbers in Caribbean countries. Additionally, because of the rapid spread of ZIKAV in South America and the Caribbean, the study is looking at how we could use similar methods to forecast ZIKAV's risk potential in the U.S.

ACCOMPLISHMENTS

The Dynamic Mosquito Simulation Model (DyMSiM) is a coupled entomological-epidemiological model used to simulate the *Aedes aegypti* population and pathogen

transmission dynamics. DyMSiM is used in conjunction with a real-time, high-resolution version of the Weather Research and Forecasting numerical weather prediction model to forecast pathogen transmission risk on a weekly basis for the study area. We are establishing procedures to obtain numerical weather prediction forecasts, run simulations, and produce disease forecasts with positive performance. Due to ZIKAV's rise as a global health risk, we produced a forecast for the *Aedes aegypti*'s potential abundance as a proxy for ZIKAV risk in the U.S. using related methods. The resulting risk maps show the contributions to ZIKAV risk from: 1) vector abundance and 2) travel from countries on the CDC Zika travel advisory.

BENEFITS

The results from the project provide a method to assess the feasibility, accuracy, and current limitations of vector-borne disease forecasting for public health agencies and officials to use, and to plan mitigation strategies to alleviate the impacts of DENV, CHIKV, and ZIKAV.

PROJECT MANAGERS: Dr. Dale A. Quattrochi, Dr. Cory W. Morin, and Mr. Bradley Zavodsky

FUNDING ORGANIZATION: Center Innovation Fund

FOR MORE INFORMATION: <https://www.cdc.gov/zika/about>

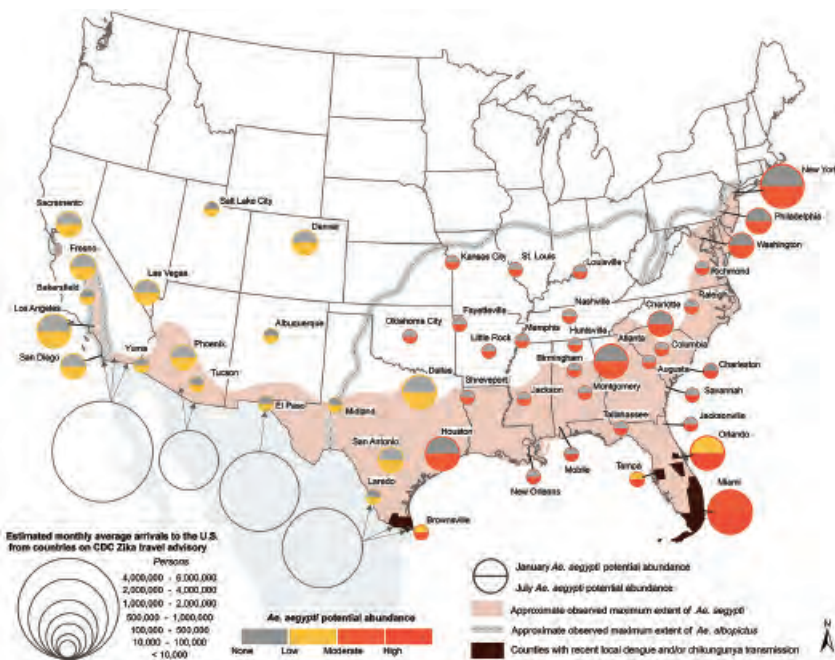

A map generated by researchers at MSFC quantifying the risk to various areas of the United States from the Zika virus. From Monaghan AJ, et al., "On the Seasonal Occurrence and Abundance of the Zika Virus Vector Mosquito *Aedes Aegypti* in the Contiguous United States," *PLOS Currents Outbreaks*, Mar 2016.

Enabling Fast-Responding Pressure-Sensitive Paint Systems in Blow Down Wind Tunnels

OBJECTIVE: *Demonstrate the utility of pressure-sensitive paint in blow down wind tunnels.*

PROJECT DESCRIPTION

During the early stages of a launch vehicle development, we use subscale models to conduct wind tunnel tests to evaluate preliminary design, stability, and performance. Two basic types of information are obtained: the distribution of air pressure over the model and the forces applied to the model due to the air flow. Since these models are small, we can only install a limited amount of instrumentation to measure pressure at discrete locations on a model's surface. Also, for tests conducted in blow down wind tunnels, the air pressure over the model's surface due to the air flow distribution is unsteady (i.e., varies with time). In this Cooperative Agreement project, Innovative Scientific Solutions (ISSI), Inc., and the University of Alabama partnered with MSFC to demonstrate pressure-sensitive paint (PSP) in blow down wind tunnel applications. PSP is painted on the model, formulated to provide a visual representation of the unsteady pressure distribution over the entire model. Testers take thousands of photographic images of the model during each wind tunnel test with the PSP applied. These images are processed to visualize the pressure distribution over the model and how that distribution varies in amplitude over time. The advantage of PSP is that each pixel of an image serves as a pressure sensor; therefore, pressure is measured at thousands of locations instead of just a few.

ACCOMPLISHMENTS

In November of 2015, tests were conducted in the University of Alabama's blow down wind tunnel, which successfully demonstrated the ability to compensate for the error in PSP data due to its sensitivity in changing temperature. In June of 2016, tests were conducted at MSFC's Aerodynamic Research Facility's tunnel using an arrow-shaped model. These tests showed that unsteady pressures the PSP measured matched the pressures measured in previous tests.



A model prepared with pressure-sensitive paint waiting for a wind tunnel test.

BENEFITS

PSP will increase the amount and quality of unsteady pressure data that, in turn, will enhance initial launch vehicle design assessment with less wind tunnel testing. Due to the savings in development time and costs, the SLS program can conduct additional PSP evaluation tests.

MSFC TECHNICAL POINT OF CONTACT: John Lassiter

PARTNER PRINCIPAL INVESTIGATORS: James Crafton, PhD, ISSI; Paul Hubner, PhD, University of Alabama

FUNDING ORGANIZATION: Cooperative Agreement Notice

Immersive Decision Making Environment for Mission-Driven Technology Alignment

OBJECTIVE: *Characterize a digital data backbone that integrates transportation architectures, upper stage engine design, and additive manufacturing to enhance mission driven decision support.*

PROJECT DESCRIPTION

NASA's systems engineering "engine" has three technical processes: system design, product realization, and technical management. This project focuses on characterizing the digital data a typical system design process requires. A growing prominence of datasets that cannot be handled efficiently in a traditional, non-relational data lifecycle model has driven new techniques in the data layer.

This project will evaluate a Methane in Space Transportation (MIST) concept using the data backbone of Siemens' Digital Enterprise Software. The intent is for each engineering department to work independently and let the data backbone provide the mechanism for accessing information across engineering departments. Engineering areas contributing to the effort included additive manufacturing, design and analysis, and mission analysis.

ACCOMPLISHMENTS

In February 2016, we stood up test servers to understand security requirements and work out potential issues. In May, we installed project servers, ready for users, and shortly afterward, on June 2, we established use cases at Kick-Off. On September 21, our status let us demonstrate baseline capabilities, e.g., to upload CAD files, check-in/out, assess state, and revise. Currently, we are evaluating use cases to characterize the data backbone properly.

BENEFITS

Broadening access to data across engineering provides insight, permitting the discovery of deeper, fresher insights, as well as increasing productivity by improving efficiency, effectiveness, and decision making. This access impacts speed as well, enabling agile responses to technological opportunities, alignment, and challenges. Last, broadened access impacts scalability, offering the ability to create new cost-effective analyses that are closer to reality.

PROJECT MANAGERS: Mark Rogers (Lead), Boise Pearson, Steven Phillips, Dave Whiten, Keith Swearingen

FUNDING ORGANIZATION: Cooperative Agreement Notice

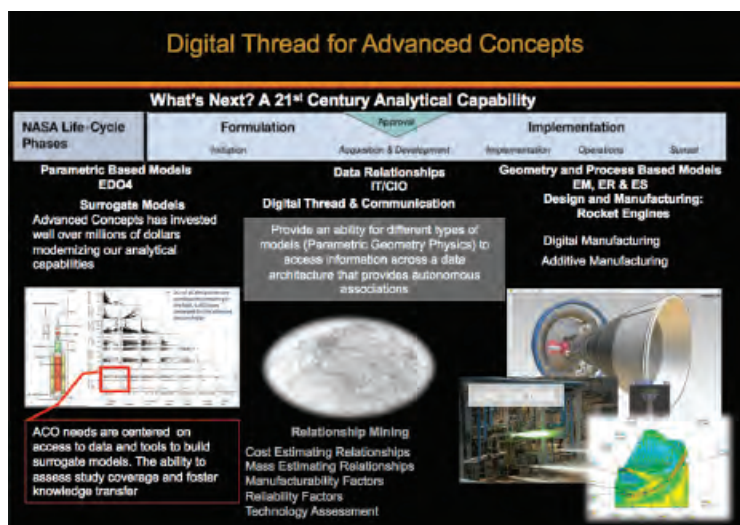

An overview of the applicability of the Digital Thread program to various applications.

Topic Mapping

OBJECTIVE: *Significantly reduce the time required to perform technology assessments by training software agents to recognize technologies from written text.*

PROJECT DESCRIPTION

This project consists of two demonstrations:

- 1) Create a technology roadmap and
- 2) Determine the technological and strategic alignment of MSFC internal proposals.

Both of these tasks require an ability to perform technology assessment from thousands of documents.

For the technology roadmap, 45 software agents are created to recognize avionic components. These agents then evaluate approximately 10,000 paragraphs on wireless sensors to determine which avionic components would benefit from wireless sensor technology. A statistical analysis then groups the evaluations into mission needs and technological challenges.

For strategic alignment, approximately 500 agents were created to recognize the technologies defined in the NASA Technology Roadmaps. Another group of agents was created to recognize MSFC tiers and strategic vectors. These agents evaluated approximately 400 proposals to determine the degree of technological alignment to MSFC tiers.

ACCOMPLISHMENTS

The project demonstrated that by using state-of-the-art data mining technology, the time to perform technology assessments is significantly reduced and the alignment to mission needs and NASA priorities is significantly improved.

The wireless sensor technology roadmap task was completed in less than a week. Normally this task would take approximately 8-12 weeks. In addition, the avionic/wireless agents can continue to be used to perform analysis and technology assessments.

The strategic alignment was completed in about a month. The longest task was creation of approximately 500 agents. After the agents were created, the evaluation of the proposal documents took very little processing time. The ability to assess and classify 400 proposals in less than an hour is a significant reduction in the time normally required to perform this task. The technology agents are now available for continued use in mission analysis and future technology assessments. The ability to use agents in Office of Strategic Analysis and Communications and Advanced Concepts Office allows MSFC to create a better portfolio of MSFC strategic tiers.

BENEFITS

This project demonstrated an ability for NASA to better manage its technology portfolio by assessing technologies that benefit both NASA mission needs and national priorities. For the U.S. taxpayer, technology is an investment through NASA programs for economic growth and scientific knowledge. This tool provides an ability to significantly improve technology portfolio management at NASA by quickly assessing the strategic and technological alignment to mission needs and national priorities.

PROJECT MANAGERS: Mark Rogers, Boise Pearson

PARTNER ORGANIZATIONS: ISC Consulting Group and AI-One, Inc.

FUNDING ORGANIZATION: Cooperative Agreement Notice

Concept Analysis Using Natural Language Understanding

OBJECTIVE: *Demonstrate an ability to read mission and technology documents with a Natural Language Understanding (NLU) engine to help extract facts.*

PROJECT DESCRIPTION

This project is attempting to build a new type of calculator using Natural Language Understanding (NLU). The calculator will review and analyze published data from scientific literature to perform technology readiness assessments (TRAs). NLU deals with a computer's reading comprehension ability. The project is currently testing this method to determine the Technology Readiness Levels (TRL) level of methane engine combustion chamber models.

NASA began to develop TRL in 1974 and formalized them in the 1980s. Today, federal agencies other than NASA, international government agencies, and commercial enterprises continue to refine TRA methods. The General Accounting Office (GAO) is in the process of creating a best practices guide to evaluate technology readiness. Currently, subject matter experts (SMEs) who provide references to papers, presentations, data, and facts which support a TRL criteria perform assessments. Many assessments use a "calculator" the Air Force developed that consists of a series of questions asking the experts to determine the TRL.

Allowing SMEs to analyze the results rather than just collect the information, this project intends to improve credibility and objectivity by identifying sources of information, establishing reliability through repeatability, and demonstrating the TRA calculator's usefulness.

ACCOMPLISHMENTS

This year, the project identified feature values from text, which let us gain insight into how to generalize and into grammar automation. We automated grammar rules and semantic composition and identified associated axioms, a process in which we worked to combine

inference engine and natural language parsing, and prepared to combine semantic composition rules with grammar rules.

BENEFITS

In systems engineering best practices, evaluations of technology maturity are a routine aspect of program management and are evident in the program planning documents that define the program strategy. A disciplined and knowledge-based approach in evaluating technology is fundamental in putting acquisition programs in a better position to succeed. Incorporating immature technologies into products increases the likelihood of cost overruns and product development delays.

Providing a new TRA "calculator" will improve credibility and objectivity by identifying sources of information, establishing reliability through repeatability, and demonstrating the TRA calculator's usefulness by allowing SMEs to analyze the results as opposed to just collecting the information. The overall benefit will be better management of Technological Portfolio Management.

PROJECT MANAGER: J. Boise Pearson

PARTNER ORGANIZATION: The Software Shop, Inc.

FUNDING ORGANIZATION: Cooperative Agreement Notice





MANUFACTURING

The twelfth technology area identified in the 2015 NASA Technology Roadmap encompasses a broad range of research and development areas, including advanced manufacturing, materials science, structures, and mechanical systems. The cross-cutting technologies included in this section will enable NASA to perform ever more daring science, human exploration, and aeronautics missions. These missions will require more lightweight materials, machines that can withstand the harsh conditions of space, and

structures that will provide the robustness and structural integrity required to endure extended exposure to extreme environments. Marshall Space Flight Center has distinguished itself as a premier Center for manufacturing and materials development, as you will see in the project descriptions that follow. These technology development efforts are relevant to this entire technology area, providing game-changing technologies for NASA's future missions, including novel welding techniques and major advances in additive manufacturing.

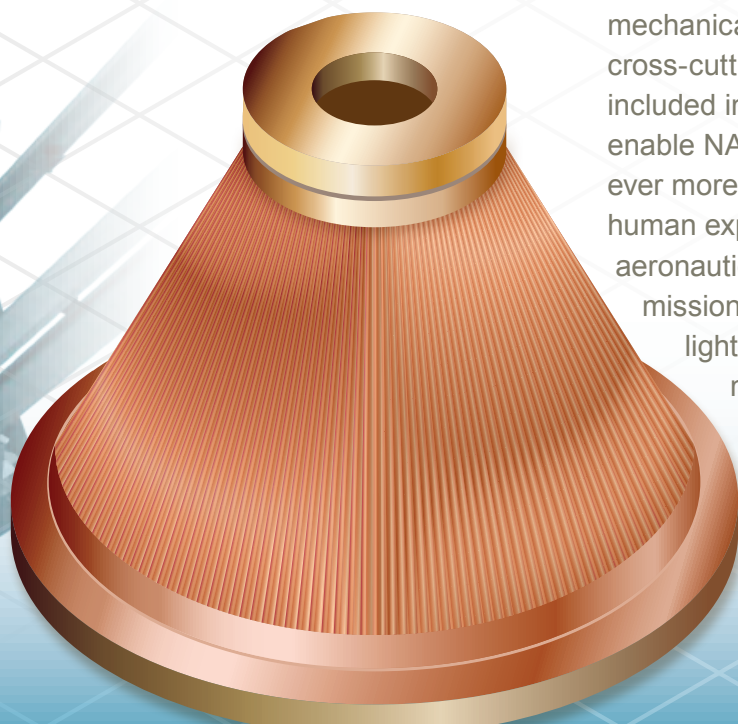

In-Space Recycler Technology Demonstration

OBJECTIVE: *Develop and build an in-space 3D printed parts recycler for demonstration aboard the International Space Station.*

PROJECT DESCRIPTION

In 2014, NASA installed a 3D printer on the International Space Station (ISS) and fabricated the first parts to be additively manufactured—that is, 3D printed—in space. While additive manufacturing can potentially be a game changing technology for on-demand manufacturing and repair during exploration missions, the process still requires raw feedstock material before it can fabricate parts. Not only will we have to launch this feedstock on expensive resupply missions and store it onboard, taking up valuable mass and cargo space, but we will still depend on the Earth.

This project’s model significantly diminishes the mass, cost, and risk savings that additive manufacturing technologies can provide. With this in mind, the NASA In-Space Manufacturing (ISM) project developed a mitigation approach that lets us recycle 3D printed parts into reusable filament which we can, in turn, use to fabricate new or different parts, thus providing a more closed loop manufacturing lifecycle. In order to develop the recycling technology needed to bring this to fruition, ISM released a Small Business Innovation Research (SBIR) call to design and build a recycling demonstration to launch to the ISS in 2017.

We awarded the SBIR to Tethers Unlimited, Inc. (TUI), for the Refabricator, which is an integrated recycler and 3D printer in one system that implements a novel approach to perform multiple recycling cycles, and 3D printing using high-quality polymer feedstock. We will collect, store, and return to NASA Marshall Space Flight Center (MSFC) the test specimens manufactured from the recycled filament, along with sections of recycled filament itself, where we can perform detailed

tests and analyses in order to enhance our understanding of the recycling process in space. This demonstration’s data will give us insight into any effects microgravity might have on the recycling process, which will in turn inform materials requirements and the design of a robust, next-generation Refabricator.



TUI In-space recycler prototype.

In addition to understanding potential microgravity effects, the Refabricator demonstration also tests the system design regarding significant operational constraints. These constraints include mass, volume, power, and astronaut time compared to facilities designed to operate on the ground. The ISS is a one-of-a-kind technology testbed which provides a unique microgravity and operations

environment that cannot be recreated terrestrially. It is, therefore, a critical platform to develop capabilities—such as the Refabricator—which long-duration exploration missions will require.

ACCOMPLISHMENTS

Recycling scrap plastic into printer filament is quite challenging because a recycler must be able to handle a large variety of possible scrap configurations and densities. Current small-scale recycling technologies are excessively labor intensive and yield even worse filament consistency issues than those that already plague virgin feedstocks. New challenges include dealing with the inevitable scrap material contamination, minimizing damage to the plastic’s molecular structure during reprocessing, managing a larger volume of hot liquid plastic, and exercising greater control over the material’s cooling and resolidification. Quality control is one of the greatest technological challenges general 3D printing faces, and more specifically, the feedstock

feature



Recycled 3D printed packaging by TUI that attenuates 2X better than the current foam we use for launch.

In May 2016, TUI finished fabricating a flight prototype, which is being developed into the Refabricator Technology Demonstration unit for the ISS. While the Refabricator is developed to meet NASA's mission needs, the capability to manufacture and recycle 3D printed parts in one system has significant terrestrial potential for global commercialization and utilization.

BENEFIT

Ultimately, this technology enables an Earth-independent fabrication capability, which provides meaningful reductions to mission costs and risks while increasing mission flexibility and autonomy.

DEVELOPMENT TEAM LEADS:

Dr. Robert Hoyt, CEO and Chief Scientist, Tethers Unlimited, Inc.; Niki Werkheiser, NASA In-Space Manufacturing Project Manager

FUNDING ORGANIZATION: Advanced Exploration Systems

FOR MORE INFORMATION: Tethers Unlimited Inc.: www.tethers.com, <https://techport.nasa.gov/view/11874>

material's consistency. TUI has developed an architecture for the Refabricator that addresses these challenges by combining standard, proven technologies with novel, patented processes developed through this SBIR effort. Results show that the filament diameter the Refabricator achieves is more consistent than commercial filament, with only minimal degradation of material properties throughout the recycling process. The recycling closed loop system provides much greater process control than the traditional plastics recycling and filament forming techniques used terrestrially. The system also benefits from minimizing the dependence on external resources, which is even more restrictive for operations on the ISS because of crew time and hardware allocation.

Manufacturing Advanced Channel Wall Nozzle Rocket Liners

OBJECTIVE: *Advance a novel abrasive water jet milling manufacturing technology to form complex coolant channels within rocket nozzles, combustion chambers, and heat exchanger components.*

PROJECT DESCRIPTION

NASA is adapting and scaling up a novel manufacturing technology to machine delicate and complex cooling features in high-temperature, regeneratively cooled liquid rocket nozzles and combustion chambers. NASA could use this technology to perform automated machining of all kinds of metals and ceramics, and its completed development will benefit advanced liquid rocket engine programs through more flexible and economic manufacturing.

ACCOMPLISHMENTS

To meet the engine designers' requirements, the process and its control were improved so that the technology can machine engine cooling channel circuits. These advancements show that new engine design features can be machined with high repeatability and within tight design tolerances. NASA has witnessed a range of advanced engine design concepts demonstrations, and completed spin-off projects demonstrating full-scale capability for commercial engine manufacturers.

BENEFITS

This technology will support the development and production of advanced liquid rocket engines that incorporate complex cooling features that currently are not feasible to manufacture. This allows for significantly increased performance with reduced lead times and subsequent reduced costs.

Engine designers are currently limited in what they can design because of current technology with traditional slitting saw or end mill capabilities. The proposed technology overcomes these limitations and supports the design and fabrication of highly complex features to optimize performance further. It was shown to reduce machine time by 90% compared to conventionally milling the same cooling channels.

PROJECT MANAGER: Paul Gradl

FUNDING ORGANIZATION: Small Business Innovative Research

FOR MORE INFORMATION: <http://ntrs.nasa.gov/archive/nasa/casi.ntrs.nasa.gov/20160009709.pdf>, techport.nasa.gov/externalFactSheetExport?objectId=18321



Examples of advanced engine design concepts manufactured using a variety of metals and machined using the novel water jet milling process.

Development of the Ultrasonic Stir Weld Process

OBJECTIVE: *Using the Ultrasonic Stir Weld (USW) process, document variations in the weld panel forces during solid state joining as influenced by the use of ultrasonics and induction coil preheating in AA2219. Expand the current friction stir weld process modeling to include the effect of ultrasonics on the material flow and, hence, processing conditions.*

PROJECT DESCRIPTION

The success of the SLS program will rely not only on using advanced structures and materials, but more importantly, on the ability to produce robust, high-strength weld joints. To support the higher loads resulting from mounting the main engines directly to the fuel tank, the material thickness of the liquid fuel tanks has increased to 0.75 in on the SLS. However, as the material's thickness increases, so do the forces involved in consolidating the material. This can jeopardize tool life, reducing the friction stir weld (FSW) process's robustness. In addition, the equipment's ability to react to these larger forces limits its applicability to in-space applications. In order to reduce these loads, the conventional FSW process must realize advancements.

A critical welding advancement at MSFC called Ultrasonic Stir Welding (USW) addresses the resistive and frictional forces typical of the FSW process. Initial studies using USW at MSFC have shown that we can reduce the forces on the non-rotating containment plate, which serves as the shoulder, significantly. We need further investigation into the combined use of USW, incorporated into the containment plate and/or stir rod, on the resulting material flow and forces to demonstrate the process reliability for solid state joining in materials in which NASA is interested.

ACCOMPLISHMENTS

We debugged the USW system at the beginning of 2016. Next, we collected weld data and characterized the whole process of ultrasonic welding.



The USW machine in use in the laboratory.

BENEFITS

The USW process reduces process forces so that we can integrate the weld process with robots for robotic applications. This also lets NASA weld thicker heat-resistant alloys.

PROJECT MANAGER: Jeff Ding

FUNDING ORGANIZATION: Cooperative Agreement Notice

Self-Reacting Friction Stir Welding on Space Launch System Core Stage

OBJECTIVE: *Successfully incorporate self-reacting friction stir welding into the manufacture of Space Launch System (SLS) Core Stage parts.*

PROJECT DESCRIPTION

Manufacturing large rockets requires that many very large components are assembled and joined. Friction stir welding, or FSW, is one of the traditional approaches used. In FSW, technicians apply heat to the two parts to be joined, causing their materials to intermix and then join. FSW using self-reacting (SR) technology has advanced the state of the art for joining two parts on their circumferences. Most traditionally used FSW requires a bulky, heavy anvil on the back side of the work piece to take the load from the FSW machine. With SR-FSW machines, the load comes back onto the FSW machine head. Eliminating the backing anvil has many advantages, including tooling cost and schedule risk reduction. Also, SR-FSW technology is fully automated and can function well in any position.

ACCOMPLISHMENTS

SR-FSW has been incorporated on several weld tools at the Michoud Assembly Facility in New Orleans, LA, to produce major components of the SLS Core Stage (CS). Technicians have used SR-FSW for all the circumferential welds completed on the primary SLS CS structures, with the exception of the intertank assembly, which is bolted. In the current fiscal year, NASA's primary contractor for SLS CS production, Boeing, successfully completed over 26,000 inches of SR-friction stir welds. The SR-FSW process was validated successfully with the construction of an SLS CS liquid oxygen (LOX) tank weld confidence article and a liquid hydrogen (LH₂) qualification tank. This paved the way to complete two flight elements, the CS LOX tank and the LH₂ tank.



FSW of SLS CS domes on robotic weld tools at Michoud Assembly Facility.

BENEFITS

Introducing SR-FSW provides several advantages. First, it is a less technically challenging process. It is also faster and more efficient, and last, it has lower tooling and production costs. The SR-FSW process is the baseline approach for the future NASA Exploration Upper Stage (EUS) program. Also, new tooling for this program will let us use it not only for circumferential welds, but also for longitudinal welds, leading to even more cost savings for human exploration missions.

PROGRAM MANAGER: Kelley Easley

FUNDING ORGANIZATION: Human Exploration and Operations Mission Directorate

Modular Tooling Approach for Manufacturing of Large-Scale Launch Vehicle Structures

OBJECTIVE: *Develop a low-cost, adaptable manufacturing approach for large launch vehicle structures.*

PROJECT DESCRIPTION

Traditional large-scale launch vehicle structures' manufacture involves expensive, dedicated tooling fixtures, and they require long lead times to fabricate. The Welding and Manufacturing Team at Marshall Space Flight Center (MSFC) has developed an innovative, low-cost, modular tooling approach, similar to a giant reconfigurable erector set, that adapts easily to a wide range of large-scale hardware configurations. This approach is distinctly novel, and it provides manufacturing flexibility and scalability, but it does so with minimal tooling changes and it results in rapid response times and significant cost savings. With all this, it still fulfills a multitude of project needs.

ACCOMPLISHMENTS

The Welding and Manufacturing Team developed and successfully demonstrated the modular tooling system to manufacture several critical spaceflight elements, including two Space Launch System (SLS) Multipurpose Crew Vehicle Spacecraft Adapters (MSAs), and a Core Stage Simulator. In FY2016, the team used the modular tooling approach to manufacture the SLS Launch Vehicle Stage Adapter (LVSA) Structural Test Article. Overall, using this tooling approach

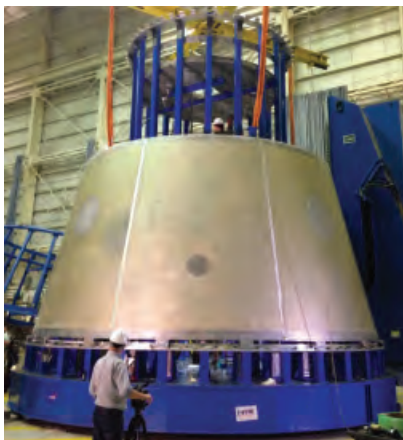

Modular tooling approach used for the LVSA.

over conventional approaches has saved NASA approximately \$5M, with potential savings of over \$15M. If necessary, we could use the modular tooling system to mitigate potential schedule and cost impacts, which would make MSFC an alternate option to support large-scale structure fabrication, such as the Exploration Upper Stage (EUS), Core Stage, and exploration-sized habitats.

BENEFITS

Implementing this innovative technology lets NASA provide and maintain national technical leadership for lower cost, large-scale aerospace hardware welding and manufacturing while drastically reducing tooling design, fabrication time, and facility footprint. The technology significantly enhances manufacturing flexibility so the Agency can respond to dynamic manufacturing needs that support a multitude of large and smaller scale projects.

PROGRAM MANAGER: Jon Street

FUNDING ORGANIZATION: Human Exploration and Operations Mission Directorate

Design and Manufacture of Pin Tools for Friction Stir Welding of Temperature-Resistant Materials

OBJECTIVE: *To reduce the cost of tools for friction stir welding temperature-resistant metals.*

PROJECT DESCRIPTION

In the friction stir welding process, a rotating pin seized in a weld seam is moved along the seam, stirring the sides of the seam together as it goes. Friction stir welds are strong and reliable, and are increasingly used in the aerospace industry in general and by NASA in particular. The pin tool must retain its strength while the weld metal softens and deforms. Steel tools can weld aluminum alloys, but finding a tool material to weld steel, or titanium or nickel alloys, is challenging. Currently, expensive materials like tungsten alloys or polycrystal-

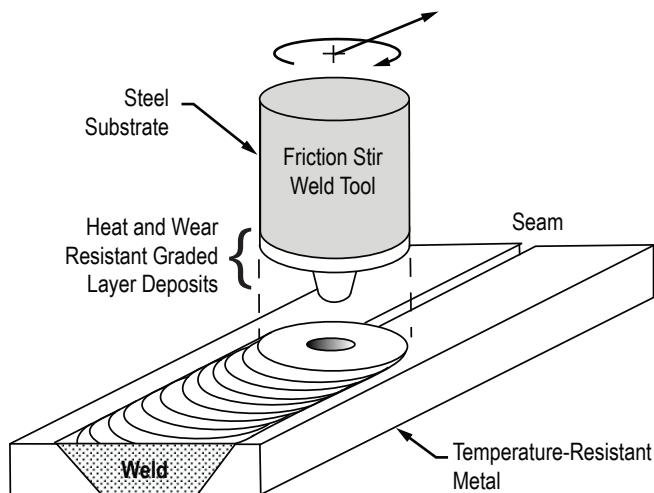

Diagram of friction stir welding process.

line boron nitride (PCBN) ceramics are required, and even these exhibit some performance problems such as wear and brittleness. But perhaps we could make composite tools, confine the expensive materials to where the tool contacts the weld metal, and make the bulk of the tool of inexpensive steel. This project explores this possibility, bonding a graded series of layers of progressively resistant compositions to the contact surface of a steel tool. Then, we test it by welding a titanium

alloy. If successful, the project will reduce the cost of pin tools for welding temperature-resistant metals substantially.

ACCOMPLISHMENTS

During 2016, we applied graded layer deposits to flat metal coupons by a laser additive manufacturing process, and we studied the resulting materials to optimize composition and process parameters before fabricating pin tools.

BENEFITS

This work intends to reduce the cost of friction stir welding applications to temperature-resistant metals like steel, titanium, or nickel base alloys. NASA and a broad base of industries— aerospace and others— would benefit from economical extension of the friction stir welding process to ubiquitous temperature-resistant alloys. Welding is a very widely used technology, and a successful result will help maintain U.S. industry's technical edge.

PROJECT MANAGER: Edward Chen, Transition45 Technologies, Inc.

FUNDING ORGANIZATION: Small Business Innovative Research

Metallic Joining to Advanced Ceramic Composites

OBJECTIVE: *Develop methods for joining ceramic matrix composite (CMC) structures to metallic components in order to empower higher performance and lower risk capabilities at elevated temperatures.*

PROJECT DESCRIPTION

This new Phase II SBIR aims to develop alternative methods to assemble a critical component in the Orion Launch Abort System (LAS)—the Attitude Control Motor (ACM) pintle valve system. That is the system that controls the Orion capsule's attitude in an abort scenario. Eight pintle assemblies control the thrust of the ACM hot gas valves, and we are investigating two joining methods for those pintle assemblies' fabrication: a vacuum plasma spray (VPS) and a high-pressure cold spray (HPCS). Each pintle assembly consists of a carbon-carbon/silicon-carbide (C/C-SiC) pintle and a high-temperature-capable metallic pintle extension. This project investigates, through the two metal deposition techniques noted above, manufacturing approaches that offer greater performance capability than the baseline approach, and at lower risk.

ACCOMPLISHMENTS

This two-year Phase II project, which began in June 2016, continues to develop the joining approaches the Phase I project pursued. To date, most of the effort has concentrated on the vacuum plasma spray process. We have fabricated (see photograph) and tested the initial test hardware, demonstrating the concept under consideration. Phase II will continue the effort Phase I began, and work to develop high-quality, high-strength joints between the C/C-SiC composite material and the spray-deposited metal. Additionally, we will pursue other joining concepts and potentially demonstrate the resulting technology in a solid rocket motor test firing.

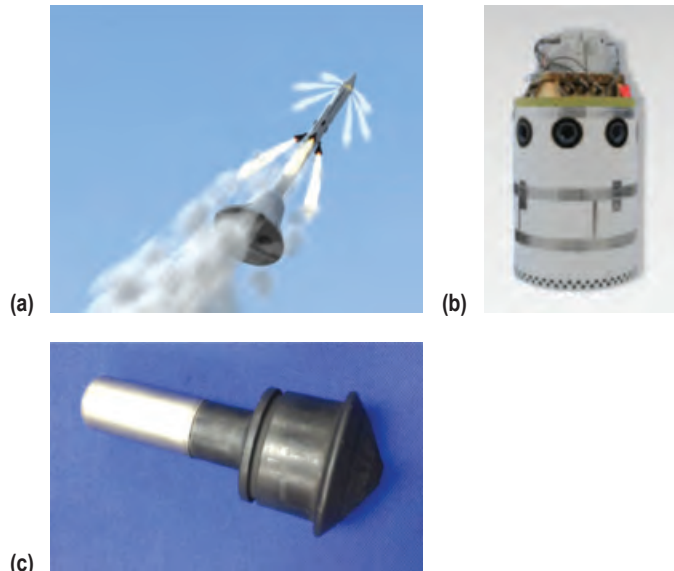

(a) Orion using the LAS; (b) Orion LAS Attitude Control Motor; (c) Phase I SBIR project demonstration article— a C/C-SiC composite pintle with a VPS fabricated pintle extension.

BENEFITS

We must meet advanced CMC materials' joining challenges to achieve success in demanding hypersonic and space propulsion applications. We need new assembly and joining methods to reduce fabrication challenges so that we do not diminish the CMC's specific strengths and high temperature capabilities. This project is aimed at developing manufacturing techniques to permit us to fabricate lower risk, higher performance components for the Orion LAS. There are numerous other high-temperature applications for the technology being developed, both within and external to NASA (Department of Defense, industry, etc.).

PROJECT MANAGERS: Timothy McKechnie and Michael Renfro – Plasma Processes, LLC (Huntsville, AL)

FUNDING ORGANIZATION: Small Business Innovative Research

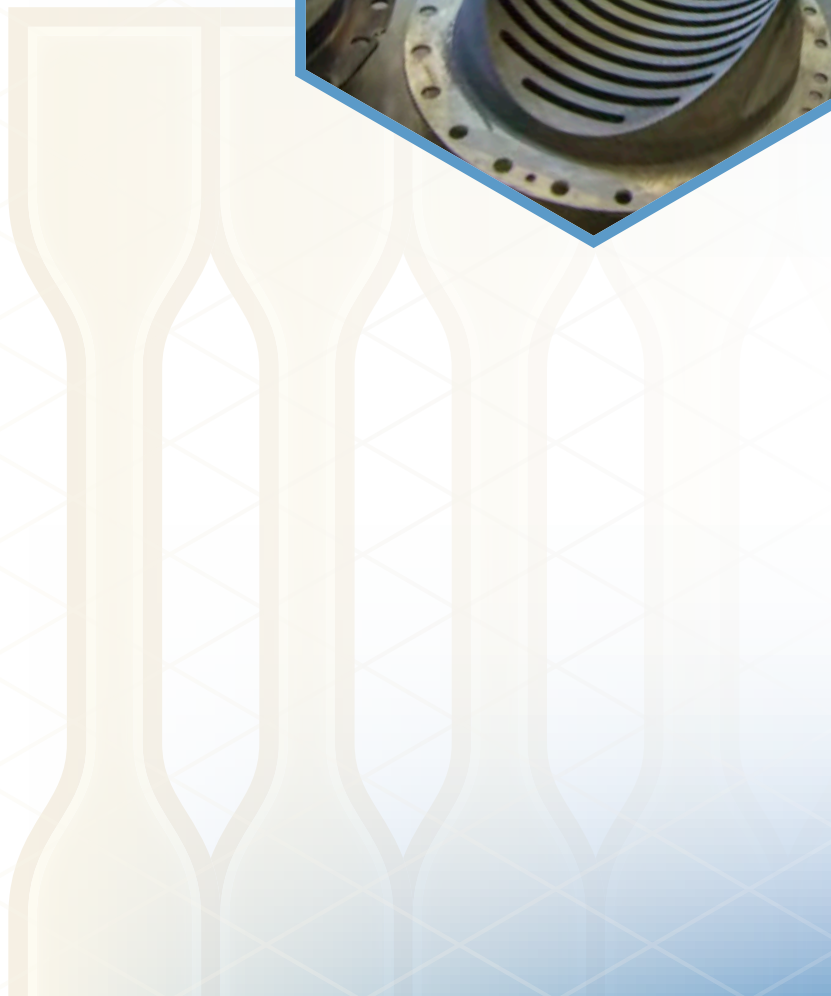



MANUFACTURING

Additive Manufacturing

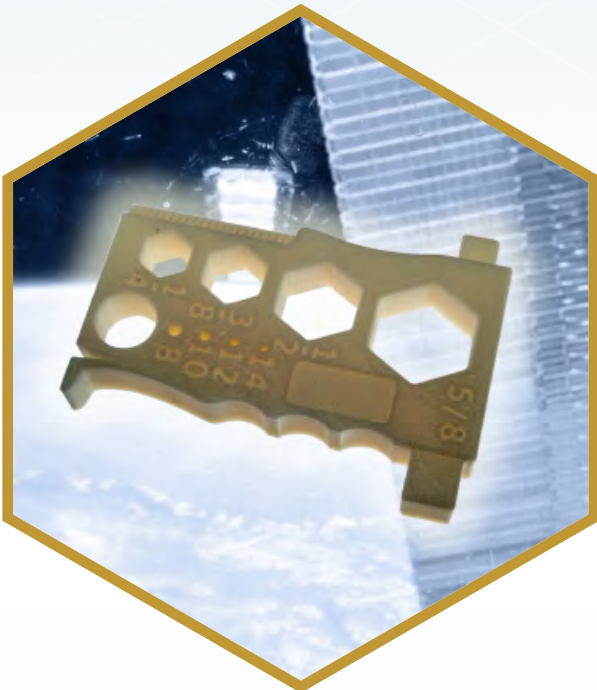

Additive manufacturing is revolutionizing the way that NASA builds components, the materials used to develop new technologies, and the future of space exploration. Additive manufacturing (AM) enables the possibility of making new parts in situ, which lends itself to the demands of long-duration space missions, where resupply is vastly limited. As the technology develops, the projects that are detailed in the following

section demonstrate that MSFC has been at the forefront of developing the capabilities of AM. The researchers associated with these projects have tackled challenges such as manufacturing parts made from multiple materials, recycling parts made using AM in order to additively manufacture new parts, and engaging the corporate world in conversations on certification of AM parts and optimization of the process.

Additive Manufacturing Facility

OBJECTIVE: *To test additive manufacturing processes in a microgravity environment.*

PROJECT DESCRIPTION

The Additive Manufacturing Facility (AMF) started as a Small Business Innovative Research (SBIR) project proposed by the company Made in Space, Inc. (MIS), and was infused into the International Space Station (ISS) program. The AMF was installed in the ISS EXPRESS Rack in April 2016; it will offer on-demand manufacturing capability to NASA, and be accessible to industry, academia, and other government agencies through the ISS National Laboratory and the Center for the Advancement of Science in Space (CASIS).

The AMF uses an extrusion-based additive manufacturing process, more commonly known as 3D printing, to manufacture parts up to 14 cm x 10 cm x 10 cm, with three different types of polymers to choose from. In addition to multiple parabolic flights through NASA's Flight Opportunity Program, the additive manufacturing process was tested in microgravity for the first time in 2014 on the ISS 3D Printing in Zero-G technology demonstration, which was also made possible by an SBIR award from NASA to MIS. The ISS 3D printing demonstration served as a critical pathfinder and risk mitigation for this novel process to be tested in the space environment.

BENEFIT

Long-term exploration missions to destinations such as Mars require a dramatic paradigm shift in logistics, maintenance, and repair. In-space manufacturing offers an elegant solution for sustainability and affordability by developing the on-demand processes, such as additive manufacturing, to address the in-space construction, repair, and maintenance of vehicles, critical systems, habitats, and uncrewed spacecraft for long-duration missions. This "Make it, Don't Take It" approach allows for a variety of parts and systems to be manufactured on-demand, directly lowering cost and decreasing risk by making available a needed part or tool in just the time it takes to print. The AMF serves as an ideal "machine shop in space" technology testbed for the evolution of this capability.

DEVELOPMENT TEAM LEADS

MANAGER(S) DESIGNERS: Mike Snyder, lead designer from MIS for the AMF; Niki Werkheiser, NASA's In-Space Manufacturing Project Manager

FUNDING ORGANIZATION: Advanced Exploration Systems

FOR MORE INFORMATION: Techport: <https://techport.nasa.gov/view/11874>, ISS National Lab: <http://www.spacestationresearch.com>, Made in Space, Inc.: <http://www.madeinspace.us>



The ISS flight demonstration additive manufacturing device provided by MIS.

In-Space Manufacturing Project

OBJECTIVE: *Provide sustainable, on-demand manufacturing and repair of parts during exploration missions.*

PROJECT DESCRIPTION

Over the next few decades, space missions will extend far beyond low-Earth orbit, and the ability to resupply failed parts or backup pieces vanishes. To prepare for long-duration missions, NASA must design and test technologies that provide accurate, automated, on-site manufacturing. The In-Space Manufacturing (ISM) project consists of three complementary technology activities focused on achieving the goal of sustainable, on-demand manufacturing and repair during these exploration missions. The three technologies are the Made In Space 3D printer, the Additive Manufacturing Facility (AMF), and the in-space recycler.

ACCOMPLISHMENTS

The 3D printer technology demonstration was the first to demonstrate a 3D printer in space. It was flown to the ISS and successfully printed specimens which have since been returned and evaluated at Marshall Space Flight Center. Subsequently, the AMF was flown to the ISS and installed in April of 2016.

The AMF also printed the winning design of the first Future Engineer's challenge on ISS. Afterward, the AMF printed an adapter to position a flow measurement probe for performance measurements of the ISS Oxygen Generation System.

To reduce the requirement for a continuous resupply of additional polymer for the 3D printers, Tethers Unlimited, Inc. (TUI), received a Small Business Innovation Research (SBIR) award to design and build the first in-space recycler for demonstration aboard the ISS in 2017. To test this technology fully in microgravity, parts will be 3D printed, recycled into reusable filament, and then reprinted into new parts.

BENEFITS

Future NASA endeavors will take crew farther than ever before, on missions where cargo resupply is limited and a return home requires months or even years. In-space manufacturing can significantly reduce logistics mass and in so doing, reduce crew risk.



Clockwise from top: Commander "Butch" Wilmore holding a 3D printed component made on ISS; the AMF installed on ISS in April 2016; the working design of the in-space recycler; the winner of the Future Engineer's Design Challenge, Mr. R.J. Hillan, talking to astronauts about his innovative tool design.

PROJECT MANAGER: Niki Werkheiser

FUNDING ORGANIZATION: Advanced Exploration Systems

3D Printed Augmented Spark Igniter for the RS-25 Engine

OBJECTIVE: *Use additive manufacturing to print spark igniters more quickly at a fraction of the original cost.*

PROJECT DESCRIPTION

Three Augmented Spark Igniters (ASIs) are used to light the two preburners and main combustion chamber of each of the Space Launch System's (SLS) four core stage RS-25 engines. The ASI is a complex injector that mixes hydrogen and oxygen in a small chamber with electrical sparks to generate a robust torch flame. The ASI's design creates unique flow dynamics that allow a core burning volume to be surrounded by a shroud flow of liquid hydrogen that keeps the interior walls of the ASI and torch tube cool. With its intricate passages and two-piece, brazed design, the heritage ASIs are historically very costly. A new ASI has been designed and fabricated with metal 3D printing technology to replace the original design. The new design is expected to reduce the cost of the igniter by a factor of four.

ACCOMPLISHMENTS

In FY2016, in a collaborative effort with Aerojet Rocketdyne, several 3D printed RS-25 ASIs were hot-fired in low-pressure component tests at Marshall Space Flight Center. Initial results indicate that the 3D printed parts performed as expected. The current plan is to incorporate a 3D printed ASI into an RS-25 certification

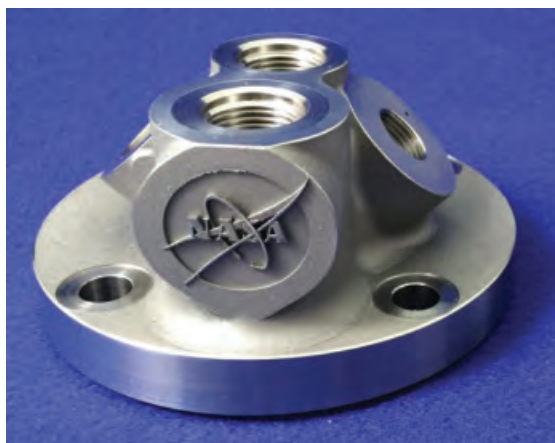

3D-printed Augmented Spark Igniter for the RS-25 Engine.

engine, which will then be tested at Stennis Space Center. Marshall Space Flight Center has been developing rocket 3D printing technology using the selective laser melting (SLM) process. Over the last several years, NASA has built and tested several SLM injectors and combustion chambers. The 3D printed ASI represents the incorporation of the technology into the powerhead of one of the nation's highest performing engines.

BENEFITS

The 3D printing SLM technology promises reduced cost and schedule for rocket engines. Cost reduction is a function of complexity with the most complicated features providing the largest cost reductions. This is especially true where brazes or welds can be eliminated. The 3D printing technology also provides a significant reduction in schedule, especially for component prototypes and initial design iterations of test articles.

PROJECT MANAGER: Robin Osborne

FUNDING ORGANIZATION: Human Exploration and Operations Mission Directorate

Achieving Certification of Additive Manufactured Hardware

OBJECTIVE: *Certify that rocket engine parts printed using additive manufacturing are as reliable as conventionally produced parts.*

PROJECT DESCRIPTION

Additive manufacturing (also known as 3D printing) is a key technology needed for affordable exploration systems. This technology can reduce the lead time and cost of hardware for multiple applications. In order to use additive manufactured hardware in human-rated systems such as liquid rocket engines, these components must be certified for flight. NASA is advancing the certification process and gaining an improved understanding of both the additive manufactured material and the part it is used to produce.

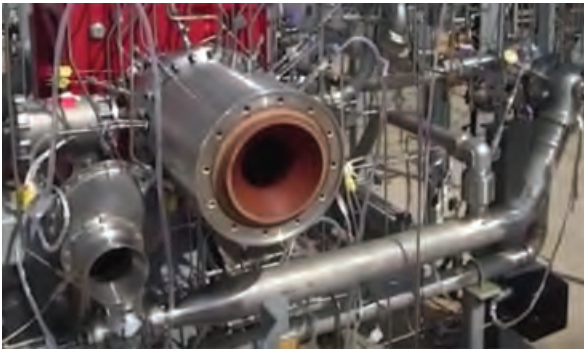

Test rocket engine.

ACCOMPLISHMENTS

To advance additive manufacturing to a level where it can be certified for crewed flight, we must understand the fundamentals of how the material is produced, as well as any possible failures that can occur during the process. To achieve this understanding, NASA is generating a database of material properties to characterize the performance of additive manufactured material that can be compared to traditionally produced material. The lessons learned during the production of these test data are allowing Marshall Space Flight Center (MSFC) engineering staff to understand the additive manufacturing process nuances and material behavior.

To understand how a part performs, MSFC engineering staff built a test configuration liquid rocket engine of additive manufactured components including injectors, turbomachinery, and valves. The liquid rocket engine was tested seven times in FY2016 using liquid oxygen and liquid hydrogen. The components have also been tested with methane for deep space engine applications. In addition to exposing the hardware to the harsh environments, engineers learned to design for the new manufacturing technique, taking advantage of its capabilities and gaining awareness of its limitations. The results of this testing and the fundamental materials research are proving that additive manufacturing will be a valuable tool enabling NASA's missions.

BENEFITS

Additive manufacturing technology aims to reduce the cost and schedule required for hardware development by reducing part costs, fabrication times, and overall part counts. In some instances, part counts were reduced from over 250 parts in a traditional part to six in the part made with additive manufacturing. This drastic reduction creates a waterfall effect and reduces the number of processes, reduces the number of drawings, decreases the amount of touch labor required, and increases reliability. When certification is achieved, NASA missions will be able to realize these benefits.

PROGRAM MANAGERS: Brian West, Elizabeth Robertson

FUNDING ORGANIZATION: Human Exploration and Operations Mission Directorate

Design, Development, and Testing of a 3D Printed Rocket Engine Turbopump

OBJECTIVE: *Design and 3D print a complex rocket engine part, followed by validation testing.*

PROJECT DESCRIPTION

Additive manufacturing (AM), or 3D printing, technology can potentially reduce costs and lead times typically associated with developing complex liquid rocket engine systems, and it could do so drastically. The In-Space Propulsion Workhorse (ISPW) program was established at Marshall Space Flight Center (MSFC) to spearhead the design, development, and testing of advanced liquid rocket engine components using this new manufacturing technology. The program's primary objective was to mature the AM technology for potential Upper Stage Engine (USE) type additive components by testing in relevant rocket engine environments.

The liquid hydrogen (LH₂) turbopump is one of the most complex components in a USE system application. This turbopump is complex because its small package delivers an unexpectedly large amount of power. The turbine produces 1,800 horsepower and provides power to the pump, which spins on a common shaft at over 90,000 revolutions per minute (RPM). MSFC completed the turbopump design, development, manufacturing, and first unit testing.



ISPW assembled fuel turbopump.

ACCOMPLISHMENTS

The design and development team adopted an aggressive strategy focused on using advantages of the AM process to reduce cost, schedule, and complexity. This effort resulted in a 45% part count reduction, which translated directly into a reduction in complexity and cost, and that truncated the design, development, and manufacturing timeline to less than 2.5 years.

At MSFC, we completed a total of fifteen performance characterization tests and nine bread-board engine system tests in FY2016. The total accumulated time on the first unit is over 250 seconds of steady state operation at speeds ranging from 50,000 to 92,000 RPM. The extensive test series has let engineers examine how turbopump parts made using AM perform, but also, the tests have matured the AM turbopump pumping systems and subsystems designs successfully.

BENEFITS

This AM technology's testing and maturation fosters the development of lower cost, more reliable, and more efficient liquid rocket engines. This can benefit future NASA robotic and human spaceflight missions, and industry can use it to benefit commercial and government customers.

PROJECT MANAGER: Marty Calvert

FUNDING ORGANIZATION: Human Exploration and Operations Mission Directorate

Empirical Optimization of Additive Manufacturing

OBJECTIVE: *Ensure repeatability of additive manufacturing processes, specifically, selective laser melting.*

PROJECT DESCRIPTION

NASA increasingly leverages processes for additive manufacturing (AM) of metals to reduce cost, accelerate development, and impart design flexibility for propulsion components. However, inherent variability in additive manufacturing processes often leads to inconsistent and undesirable properties in the finished material. We can use in-process sensing of additive manufacturing processes, specifically selective laser melting (SLM), to ensure build repeatability, mitigate risk, and aid in certification of additively manufactured flight hardware. Universal Technology Corporation (UTC) and Wright State University (WSU) are developing the first framework to optimize sensor data collected in situ during SLM, a process NASA uses primarily to build propulsion hardware.

ACCOMPLISHMENTS

This effort uses sensor data collected during SLM builds of Inconel 718, a material commonly used in propulsion applications, to assess build outcomes. To date, experimentation with UTC's open-architecture SLM testbed have correlated in situ data on surface texture with density of the as-built material by integrating a high-speed laser line profilometer into the system. Future work will look at the relationship between surface profile information and particle ejecta to mechanical properties and microstructural characteristics. Phase I STTR effort's outcome will be implementation of real time selective multimodal data acquisition for SLM. Developing these correlations and optimizing in situ data collection is the basis for decision making tool(s) required to develop a robust feedback loop (see figure). While errors detected in the build can inform targeted nondestructive and/or destructive evaluation of the finished part, process control software may eventually sense material deficiencies during the build and adjust processing parameters to correct for them in real time.

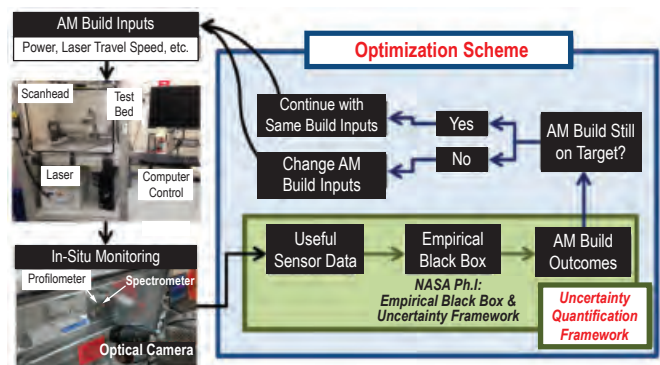

Visualization of optimized data collection framework and feedback loop for selective laser melting testbed; an overview of Advratech's R&D testbed and a closer look at a multi-modal in-process monitoring experiment are shown.

BENEFITS

Manufacturing applications use commercial off-the-shelf AM machines in an array of industries with stringent functional requirements on structural hardware. Often these machines do not include sensing capabilities that can help evaluate the as-built material and assess manufacturing repeatability. Advratech and WSU are developing a low-cost sensor suite to integrate into commercial AM machines to witness the build, assess build-to-build variability, and quantify uncertainty. This unique approach does not rely on a set of complex, underlying differential equations to predict material outcomes. It can run in real time as the AM system operates. The work will create optimized empirical models to identify problems during a build, and a low-cost sensor suite and software package to integrate into existing machines to monitor direct metal AM processes. These activities will accelerate AM process development and enable pioneering additive manufacturing technology applications for both space and Earth.

PROJECT MANAGERS: Dr. Greg Loughnane, Wright State University; Dr. John Middendorf, UTC

FUNDING ORGANIZATION: Small Business Technology Transfer

Loop Heat Pipe Manufacturing for CubeSat Applications

OBJECTIVE: *To develop and demonstrate additive manufacturing of complex loop heat pipes to miniaturize and drastically reduce the cost of these components.*

PROJECT DESCRIPTION

Large spacecraft use loop heat pipes to acquire, transport, and reject heat from critical components to protect them from the thermal extremes encountered in space. Loop heat pipes use two phase flow (vapor and liquid), vapor pressure differences and capillary forces to drive the working fluid that carries the heat. A loop heat pipe can transport large amounts of heat throughout relatively large spacecraft passively (using no electrical power), reliably, and for long durations. Loop heat pipes, however, are typically quite expensive and are used only for space missions that can afford them. This effort investigates using an advanced additive manufacturing method known as Direct Metal Laser Sintering (DMLS) to build up a complex capillary wick for the evaporator section, the most expensive component in a loop heat pipe. Using DMLS eliminates the intricate and labor-intensive machining activities, promising a reduction in loop heat pipe cost by a factor of 10 to 100, miniaturization, reliability, and performance improvements. The effort will build a demonstration loop heat pipe based on requirements for high-power microsats using DMLS, and will test the pipe's performance.

ACCOMPLISHMENTS

Additive manufacturing techniques are fairly new, and various industries are exploring the benefits these techniques can provide—specifically DMLS. A DMLS-fabricated loop heat pipe is a new application of this technique and a new approach to building this intricate component. So far, the company has fabricated sample capillary wicks, tested their porosity and permeability (parameters important for heat pipe performance), and selected desired DMLS process settings to make a demonstration evaporator. The company has started making this evaporator and remaining loop heat pipe components. Performance and life testing begin when the assembly is complete. Design and fabrication of a prototype loop heat pipe for a microsatellite will follow.

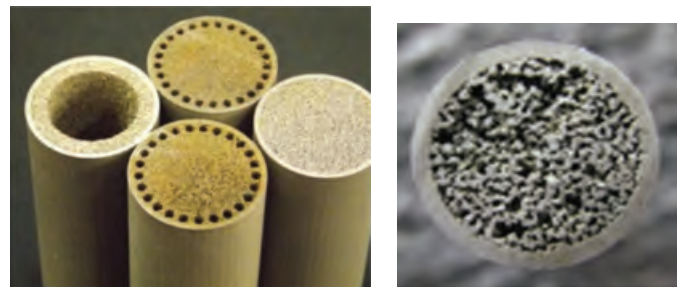
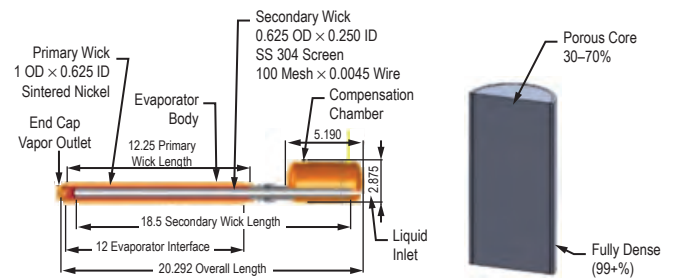

Loop heat pipe evaporator fabrication using DMLS.

BENEFITS

Microsatellites are, by nature of their size, usually quite limited in power and thermal control capability, which limits their ultimate usefulness, the kinds of missions they can perform, and the places they can go. The DMLS technique applied successfully to this type of thermal control device, lowering the cost to targeted levels, could encourage a whole new class of microsatellite missions and drastically increase the attractiveness of this class of spacecraft for NASA and DoD missions. In addition, it could increase loop heat pipe technology's performance and attractiveness in general. Also, lowering the cost and increasing the microsatellite capabilities will increase access to space for universities and smaller companies, thereby strengthening and expanding the space industry.

PROJECT MANAGER: Dr. Bill Anderson, Advanced Cooling Technologies, Inc.

FUNDING ORGANIZATION: Small Business Innovative Research

An Additive Manufacturing Technique for the Production of Electronic Circuits

OBJECTIVE: *To produce fully functional electronics circuits using a novel 3D printing process.*

PROJECT DESCRIPTION

This project aims to develop additive manufacturing techniques to create electronic devices, resulting in an innovative technique. The new technique combines ink-based printing with laser melting technology to directly 3D print a multimaterial part with embedded electrical properties. Combining these technologies will let engineers print fully functional electronic devices.

ACCOMPLISHMENTS

During 2016, the project investigated new materials and methods of curing and laser melting, and developed a potential ink injector design and 3D printer configuration, all specifically adapted to 3D print electronic circuits. The 3D printed ink-based materials are produced using a high-speed centrifugal mixer combining nanopowders with a UV-curable epoxy resin. We purchased and tested various nanopowders with various combinations of epoxy mixtures. We obtained preliminary data on the ink curing time using UV light over a range of times from 20 to 120 seconds, and we optimized the performance of the cured materials by manipulating the weight fraction of the semiconductor nanopowders and epoxy. In order to understand the nanopowder material conductivity and resistivity, we investigated laser melting of the conductive and semiconductive nanopowders. We applied a pulsed laser with energy

of a few mJ per pulse laser to the ink-based, finely-dispersed nano/micro powder of conductor/semiconductor/insulator materials the 3D fabrication technique uses. Additionally, we designed a potential ink-based injector and printer concept. The injector is outfitted with an interchangeable cartridge with fixed XYZ control. A barcode on each cartridge will identify the material type.

BENEFITS

This work will provide key elements the direct 3D printing of electronic devices requires. It potentially gives NASA an advanced manufacturing process to produce electronics in space. Additionally, this project could result in a commercial 3D printing technique for semiconductor materials that is crucial for in situ on-demand fabrication of printed electronics for in-space advanced avionics manufacturing. With their portfolio evolving to deep space-centered missions and long term presence beyond low-Earth orbit, NASA must give critical attention to processes involving the development, replacement, and repair of essential avionics to support the respective missions. As a result of the development of the novel additive manufacturing processes this project describes, technology transfer could help commercialize and package this advanced manufacturing technology for use in U.S. manufacturing, resulting in producing complex electronic products locally, faster, and more affordably for the public.

PROJECT MANAGER: Dr. Chance Glenn Sr., Morningbird Media Corporation

FUNDING ORGANIZATION: Small Business Technology Transfer

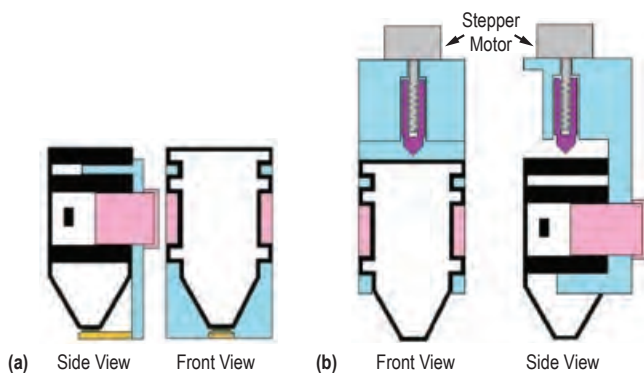

Schematic of the printer injector design: (a) cartridge station and (b) printer head.

Toward In-Space Additive Manufacturing of Thermosets with Embedded Fibers

OBJECTIVE: *To overcome the operating temperature limits of currently employed thermoplastic materials by developing extruded printing of thermoset materials with embedded fibers.*

PROJECT DESCRIPTION

To produce parts in space for repairs, instrumentation, or convenience (e.g., an astronaut recently requested a 3D printed back scratcher), we use FDM to extrude thermoplastics through a nozzle from reels of ribbon-like feedstock. This process is an adequate proof of concept that helps us understand the economic and physical requirements for in-space additive manufacturing (ISAM), and will lead to useful applications for spacecraft. The fundamental physical issue that a material formed through melting will deform again if exposed to temperatures similar to those used during forming, however, will always limit FDM with thermoplastics. That is, improvements in thermoplastics' high-temperature properties require materials with high glass transition and high processing temperatures, which can result in continual development of processing machines that require operation at ever higher temperatures. This research focused on modeling and testing extruded thermosets in a controllable fashion with fast thermal curing of the material, which should control lateral spreading and limit the resolution of printable features.

ACCOMPLISHMENTS

The technological advancements since the beginning of FY2016 are that we modeled the spreading and extruding behavior of noncuring, Newtonian liquids, and began characterizing the time-varying rheology of thermosetting materials. We characterized contact angle and spreading of curing droplets on a heated surface, and we also built and tested a prototype additive manufacturing machine for thermosets with Rutgers. This project also began to build a customizable additive manufacturing machine with high-resolution stages and a dispenser with an MSFC summer intern from Rutgers. Last, we purchased and set up a speed-mixer

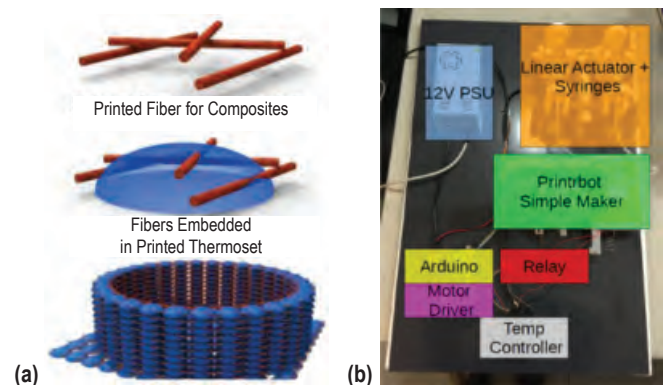

(a) Example of embedded fibers in thermoset materials and (b) extruded thermoset prototype printer.

for future dispersion of fibers in resins. As an overall assessment, we began our efforts in numerical modeling.

BENEFITS

The development of an experimental and theoretical platform that serves as springboard for further research and additional funding for long-term development of ISAM and CAM with thermal-curing thermosets demonstrates the benefits from this year's work. The results let us explore the physical tradeoffs between gravity, curing kinetics, surface tension, viscosity, size of the extruding nozzle, rate of deposition, motion of the nozzle, and composite fiber properties. We anticipate benefits that include creating design rules for building future machines and selecting appropriate thermal-curing thermosets of high-performance materials and structures for ISAM, and developing the first extruded thermoset additive manufacturing machine. We anticipate future machines based on this technology to bridge the gap between producing geometrically sound features and extruding materials with suitable strength and thermal endurance to use in space structures. In summary, this work has matured advanced additive manufacturing for future in-space applications.

PROJECT MANAGER: Patrick V. Hull

FUNDING ORGANIZATION: Center Innovation Fund

Bimetallic Additively Manufactured Main Combustion Chambers

OBJECTIVE: *Develop a process for applying an outer layer of high-strength metal to additively manufactured copper to enhance structural integrity.*

PROJECT DESCRIPTION

The bimetallic-clad combustion chamber builds upon development work completed under the Low-Cost Upper Stage Propulsion (LCUSP) program and further develops industry capabilities for propulsion additive manufacturing. Under the LCUSP program, we began to develop additive manufacturing (3D printing) of GRCop-84 combustion chambers at MSFC. (GRCop-84 refers to Glenn Research Center Developed Copper, a copper-chromium-niobium alloy.) This process developed the parameters, post-processing techniques, and material property testing for the additive manufactured GRCop material. Additionally, using an electron beam freeform deposition technology, we developed a bimetallic Inconel 625 jacket process. This development under the Technology Investment Program (TIP) advances the process by providing alternate bimetallic jacket cladding to allow for a low heat input wire-fed laser and arc-based deposition process. This permits minimal distortion to the component and minimizes opportunities for cracking as a high-integrity bond is formed.



Bimetallic additive manufacturing samples.

ACCOMPLISHMENTS

When the proposed project began, bimetallic additive manufacturing using the arc-based and wire-based laser deposition technology was very immature. This technology development project has advanced research in this area and demonstrated the feasibility of industry capabilities and a supply chain for this technique to provide high-integrity joints. In addition to demonstrating the technique on subscale hardware, the project saw completion of several development and cut-up samples.

BENEFITS

Bimetallic joints provide design and manufacturing development advancements for regeneratively cooled hardware such as combustion chambers, nozzles, and other heat exchanger components. Bimetallic joints let the design include varying materials that facilitate strength requirement optimization, performance metrics (such as weight, fabrication schedules, and cost), heat transfer characteristics, and material compatibility.

To make full use of the benefits of additively manufactured combustion chamber liners that use copper, a process must be developed to provide structural support to the liner with a stronger material. Cladding techniques provide a feasible solution to leverage the liner advantages.

PROJECT MANAGERS: Greg Barnett and Paul Gradl

FUNDING ORGANIZATION: Technology Investment Program

Space Environmental Effects on Additively Manufactured Parts

OBJECTIVE: *Modify space environment simulators for higher fidelity to actual space environment, and characterize the improved performance by testing additively manufactured materials samples.*

PROJECT DESCRIPTION

The 3D printer installed on the International Space Station (ISS) in 2014 has printed over two dozen parts. This technology is maturing with stronger materials, including rocket engine parts that, for an exploration mission, may be exposed to space for weeks and months, not just minutes. Eventually, either on ISS or on manned missions elsewhere in the solar system, we will need to replace a part that will be exposed to space. This project generates the data needed on how durable 3D printed materials might be in the space environment. The 3D printed part testing also exposed improved UV radiation sensors, and the UV radiation simulator was better characterized. Eventually, we will select one of the UV radiation sensor designs to fly on the first flight of the Materials on International Space Station Experiment Flight Facility (MISSE-FF).

ACCOMPLISHMENTS

We exposed samples of Ultem 9085 and improved UV sensors to 500 and 1,000 equivalent sun-hours of UV radiation. This was enough for visible UV damage and changes in thermo-optical properties. We also exposed samples of Ultem 9085, Inconel, and GRCop-84 to atomic oxygen, which can severely damage materials. (Atomic oxygen occurs where UV radiation breaks down ozone in Earth's upper atmosphere, generally 100 to 1,000 km altitude.) The technology advanced from no data available to TRL-5 for Ultem 9085, Inconel, and GRCop-84. We noted possible effects of assembly orientation, with mass loss slightly higher for some Ultem samples, depending on how they were printed.



Four UV-exposed Ultem samples, control sample on right.

BENEFITS

As part of Living and Working in Space, this effort helps develop in-space manufacturing capabilities and advance towards more sophisticated parts. The new UV sensors are small enough for flight, not only on MISSE-FF, but also on CubeSats.

PROJECT MANAGER: Miria Finckenor

FUNDING ORGANIZATION: Technology Investment Program

Selective Laser Ablation and Melting

OBJECTIVE: *Develop a new and innovative additive manufacturing process to produce complex, lightweight components resulting in defect-free, net-shape components requiring little-to-no machining.*

PROJECT DESCRIPTION

In this project, Advratech plans to develop an entirely new additive manufacturing (AM) process that adds existing surface profilometry, or roughness, and laser micromachining to the standard selective laser melting (SLM) process. To date, this approach to additive or hybrid manufacturing does not exist. To complete this project, Advratech added subtractive laser micromachining capability to their current SLM system, then developed the system integration methods necessary to automate both the melting and machining processes. The research team then developed methods for in situ micromachining to complete project goals, including: developing sidewall machining that improves geometric accuracy and surface finish, developing machining steps to increase build resolution, and developing profilometry-guided micromachining to remove high spots and other defects from every or any layer of a build. The research team also investigated other potential process improvements, such as microstructural refinement.

ACCOMPLISHMENTS

During 2016, the selective laser ablation and melting (SLAM) system was fully built and integrated, including adding a thermal subtractive laser into the SLM testbed.

We tested and verified automated control of build processes. The SLAM system offers dramatic improvement in build resolution (200- μm holes have been built through parts), in surface finish on component sidewalls compared to SLM, and in geometric accuracy. Using the SLAM system, inaccuracies are machined off of sidewalls, and high spots and defects can be completely removed from every layer. Additionally, we recorded full 3D documentation for each build process.

We also developed software algorithms to identify defective areas and automatically generate error maps for in situ machining, and the team verified refinement of microstructural properties through layer-by-layer laser peening.

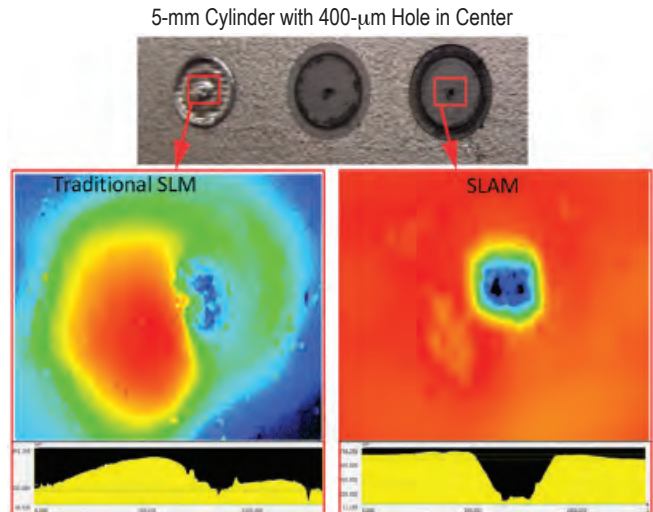

Height maps of a 5-mm-diameter cylinder built by traditional SLM on the left and SLAM on the right. With traditional SLM, geometric defects occur quite often and are not corrected. The same component built with SLAM has a nearly flat, machined surface and better geometric resolution on the small center hole. Both parts are shown as-built.

BENEFITS

Subtractive laser micromachining, guided by optical profilometry, will increase build resolution, allow correction of errors before they propagate, and improve surface quality. Technological advancements in AM will benefit any agency (government or private) that wants low-cost manufacturing of high-fidelity parts. In situ control of component microstructure will also yield components with improved mechanical properties. SLAM will make higher quality component manufacture possible, simultaneously improving build success rate and providing in-process geometric verification.

PROJECT MANAGER: John Middendorf, Advratech

FUNDING ORGANIZATION: Small Business Innovative Research

Embedded Wireless Strain Sensors for Rapid Characterization of Structural Health

OBJECTIVE: *The design and fabrication of a novel class of wireless strain sensors for structural health monitoring.*

PROJECT DESCRIPTION

Characterization of structural health with wired, surface-mounted strain sensors is expensive and time consuming. To reduce costs and permit rapid characterization of mechanical strain of composites with additive manufacturing-based, polymeric components for space systems, we are researching the design and fabrication of a novel class of wireless strain sensors.

ACCOMPLISHMENTS

There are a number of deficiencies in existing wireless strain sensing technologies for potential use by NASA and others. First, conventional wireless sensors often require a battery that limits the lifetime of the devices. Second, passive sensors need no batteries, and third, operating temperatures are rather limited.

BENEFITS

The sensors in this research could improve situational awareness of space object interactions, and wireless strain sensors on or within the structure of a CubeSat or spacecraft would be capable of monitoring impact with space debris. On Earth, the wireless strain sensors will contribute to small spacecraft intended for quick turnaround and low cost by embedding or mounting sensors to avoid the laborious, time-consuming, and expensive tasks of instrumenting test structures with wired sensors. The wireless sensors would facilitate both accelerated testing of spacecraft at low cost and improved situational awareness during flight or operation in space.

PROJECT MANAGER: Patrick V. Hull

FUNDING ORGANIZATION: Technology Investment Program

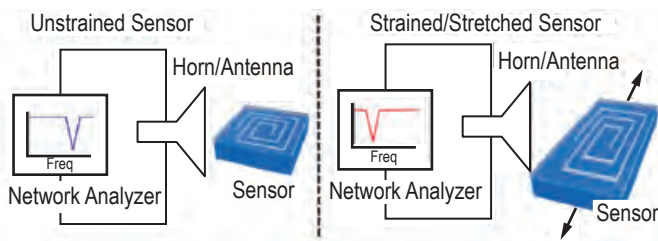

Diagram of the experimental configuration for testing the wireless strain sensors.

In this project, we demonstrated a wireless soft sensor, and designed and fabricated wireless strain sensors. Then we tested the wireless sensors successfully in a laboratory environment. We also modeled and designed electromechanical components. We have begun filing a New Technology Report (NTR).

As an overall assessment, we have been able to design, build, and test a proof-of-concept wireless strain sensor hardware in less than a year.



MANUFACTURING

Materials Development

Materials define some of the most basic limitations when considering a potential mission or destination in the solar system. For example, materials that provide sufficient radiation shielding are required for manned spaceflight outside of

Earth's magnetosphere.

Alternatively, the overall size of a space probe may be limited by the materials available to build it and to outfit it with instruments, relative to the available thrust to launch it into space. Space exploration requires

novel materials for unique applications, lightweight materials to reduce mass, and robust materials to contain potentially hazardous propellants and other chemicals. Therefore, improving lightweight materials, flexible material systems, and extreme environment materials addresses key near- and long-term mission technology needs for advanced structures, propellant depots, heavy lift vehicles, and critical concepts for human radiation protection. The projects that follow are generating new materials that can withstand the extreme heat of rocket propellant and the extreme cold of space.

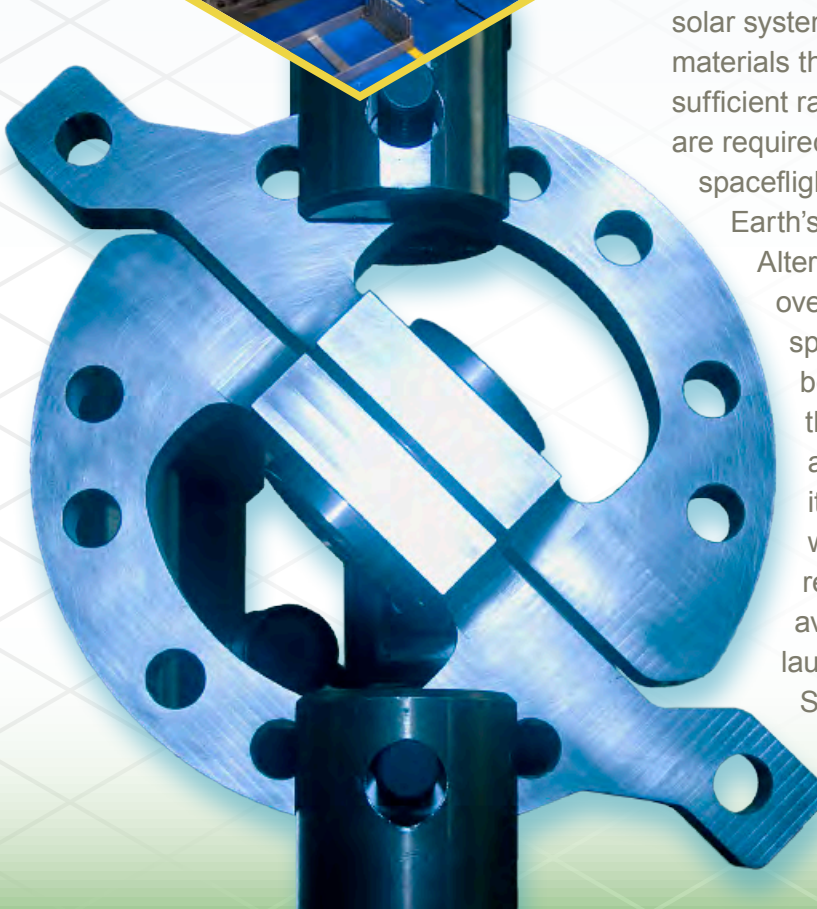

Diamond-Based Propulsion Materials

OBJECTIVE: *Low-cost diamond/copper composites for improved liquid-cooled rocket nozzle liners.*

PROJECT DESCRIPTION

This SBIR Phase I is developing tailored, low-cost diamond/copper composite materials that are highly conductive thermally and weigh less than existing materials used for reusable liquid oxygen/methane liquid rocket engines in space exploration and commercial space flight. The material's performance range spans from cryogenic temperatures to 600 °C under extreme heat flux with minimal thermal degradation. This material will help NASA achieve its goals for both human exploration and robotic exploration of the solar system.

ACCOMPLISHMENTS

High material cost and processing difficulties hindered early development of copper/diamond. These difficulties resulted in poor distribution of the diamond filler and caused it to have limited machinability.

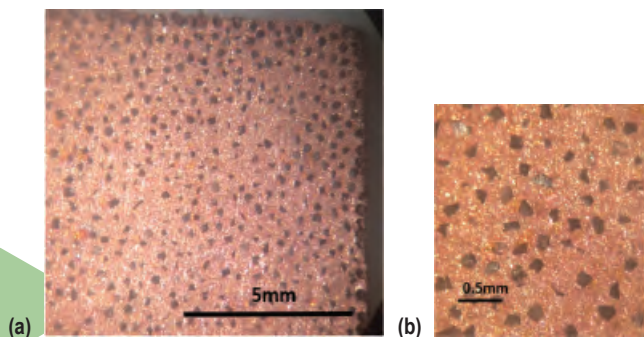

(a) Diamond particle distribution in blended diamond/copper sample containing 40 % volume diamond particles. Diamond particle size – 350 microns (50/60 mesh).
(b) A higher magnification view.

Developments in 2016 include using less expensive copper-coated diamond particles for maintaining better particle dispersion in the consolidated part, and using reduced size diamond, which is easier to machine yet still maintains the target goal of thermal conductivity

greater than 600 W/m.K (1.5× that of copper) at 30% reduced weight. We have made subscale rocket nozzle liner sections using both hot pressing and Spark Plasma Sintering (SPS) processing. We intend to use a powder bed additive manufacturing approach along with Integrated Computation Materials Science and Engineering (ICMSE) for processing control to make near-net-shaped diamond/copper parts.

BENEFITS

Lighter weight, higher performance propulsion components with increased payload capability will benefit discovery and exploration programs and the commercialization of space. Multiple Department of Defense programs can benefit from this development, including the Air Force Hydrocarbon Boost (HC Boost) heavy lift program.

PROJECT MANAGER: PI – Todd Johnson, Global Technology Enterprises

FUNDING ORGANIZATION: Small Business Innovative Research

Novel Functionally Graded Coating System for Reusable Very High Temperature Applications

OBJECTIVE: *Develop a method to fabricate functionally graded coating systems for carbon-carbon (C-C) composites intended for applications requiring multiple thermal cycles up to 4,000 °F.*

PROJECT DESCRIPTION

This new Phase I SBIR aims to develop an extremely high temperature capable material system to use with liquid propulsion systems that require multiple engine firing cycles and operational temperatures up to 4,000 °F. Specifically, the project's goal is to demonstrate a method to fabricate functionally graded ceramic coating systems to use with carbon-carbon (C-C) composites that must survive multiple exposures up to 4,000 °F. The coating system is to be applied using chemical vapor deposition (CVD) techniques and will use carbon, silicon carbide (SiC), and hafnium carbide (HfC) constituents. We are investigating both two-directional (2D) and 2.5D C-C composites to address a range of potential space access and exploration applications, including those requiring improved through-the-thickness material properties for greater performance capabilities.

ACCOMPLISHMENTS

This six-month Phase I project, which began in June 2016, is fabricating and testing a variety of C-C substrate and coating systems. Included in the evaluation effort are both coated C-C systems using currently available materials and the new systems being developed in this project, which hope to improve the technology originally demonstrated for the Hyper-X Mach 10 hypersonic vehicle. Part of the effort's goal is to show the significant performance improvements the new coating system offers. Preliminary results of elevated temperature testing in an oxidizing environment have shown significant improvements in both resistance to oxidation and to spallation.

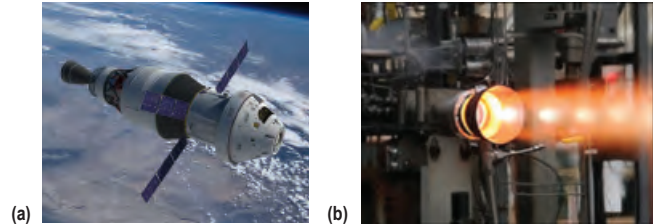

(a) Orion with Interim Cryogenic Propulsion Stage with a C-C nozzle extension; (b) Hot-fire test of subscale Orbital ATK nozzle extension at MSFC – similar testing would be used as part of a Phase II project to demonstrate the capabilities of the Allcomp functionality-graded coating system with an Allcomp C-C nozzle extension.

BENEFITS

Carbon-carbon composites are an attractive material type for nozzles and nozzle extensions for liquid-fuel rocket propulsion systems. They have low mass and high temperature capabilities compared to metallic and ablative alternatives. The coated C-C system being developed under this project should apply to a range of launch, in-space, and ascent/descent propulsion needs for a variety of NASA, Department of Defense, and commercial space vehicles and spacecraft.

PROJECT MANAGERS: Wei Shih and Steven Jones – Allcomp, Inc. (City of Industry, CA)

FUNDING ORGANIZATION: Small Business Innovative Research





THERMAL MANAGEMENT

The most fundamental goal of a thermal management system is to maintain the temperatures of a sensor component, instrument, spacecraft, or space facility within the required temperature limits, regardless of the external environment or the thermal loads imposed from operations. The thermal management systems

technology area can be divided into three main categories – cryogenic systems, thermal control systems, and thermal protection systems. While MSFC is employed in analyses that span all three categories, the projects that follow focus on the goal of creating advanced cryogenic systems to enable future long- duration missions.

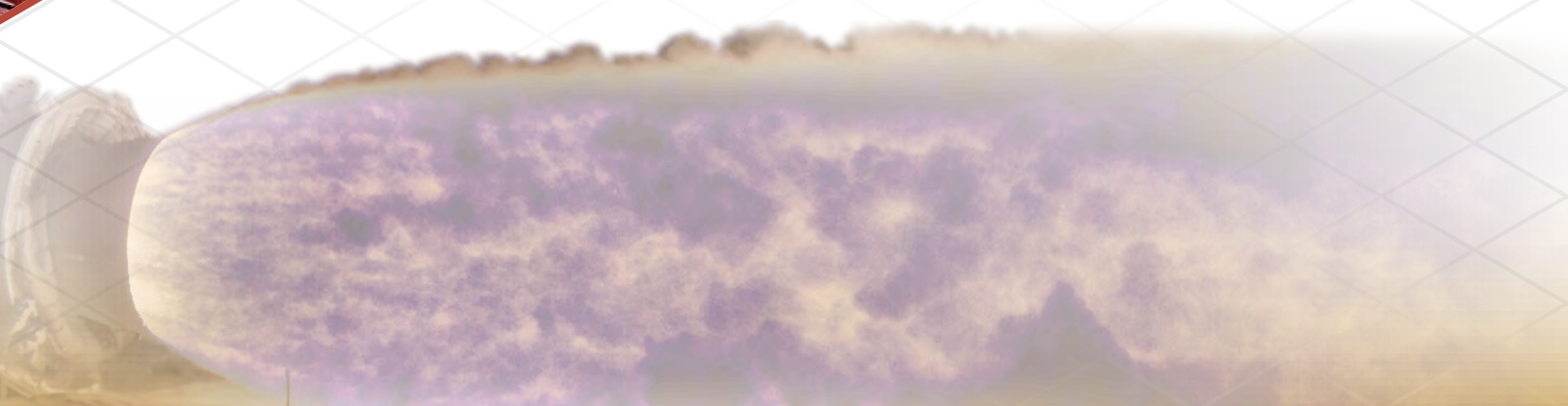

A High-Efficiency Cryocooler for In-Space Cryogenic Propellant Storage

OBJECTIVE: *To begin the development of a high-capacity, high-efficiency, “flight-like” cryocooler to enable long-term storage of liquid oxygen and liquid methane in support of NASA’s long-duration missions to Mars.*

PROJECT DESCRIPTION

NASA’s long-duration missions, such as the crewed Mars surface mission scheduled for 2036, requires us to store cryogenic propellants for extended periods of time (~ 3 years). To enable long-duration cryogen storage, we need advancements in Cryogenic Fluid Management (CFM) technologies. CFM’s purpose is to minimize heat input and actively remove heat from propellant tanks, which will limit the cryogen boil-off rate. The process requires both passive and active CFM elements, that is, high-efficiency and high-capacity cryocoolers.

Creare is focusing on developing a high capacity reverse turbo-brayton cycle cryocooler that provides 150 W of refrigeration at 90 K, which is applicable for both liquid oxygen and liquid methane.

On this Phase I SBIR, Creare will leverage off of previous development efforts to design the higher capacity cryocooler, conduct assessments of size, mass and performance, and assess the development risk. Under a Phase II SBIR, Creare will develop and demonstrate critical components. Under a Phase III, Creare will build and demonstrate a prototype cryocooler.

ACCOMPLISHMENTS

Creare identified from Aerospace Report TOR-2013(3905)-4 the space cryocoolers currently available. None of the available units have the cooling capacity. Leveraging off of previous development efforts of their reverse turbo-brayton cycle cryocooler, Creare proposed a 150 W at 90 K cryocooler and selected a design point which minimizes technical risk and exceeds both the specific mass and power requirements of the SBIR proposal call. Compressor, turbo-alternator, and heat exchanger design are complete. The baseline schematic of the electronics design is final, and the solid model

of the electronics and initial packaging development is in-work. The cryocooler packaging will define the system mass and size, as well as the thermal, fluid, mechanical, and electrical interfaces. Creare is on schedule to complete the design and address the technical objectives within the contracted schedule.

BENEFIT

A high-capacity, high-efficiency, “flight-like” cryocooler is essential for enabling NASA’s long-term missions to Mars. Currently, space cryocoolers simply do not have the refrigeration capacity needed to remove heat from NASA’s large-scale propellant tanks. Active cooling via cryocoolers is an element of CFM in which more technology development is needed before it can be implemented in a flight demonstration. Short-duration missions can use passive CFM elements alone. However, in long-duration missions (typically greater than 30 days), active cooling and the passive CFM elements are in place to minimize the refrigeration and electrical supply requirements of the cryocooler.

PROJECT MANAGER: Dr. Mark V. Zagarola, Creare

FUNDING ORGANIZATION: Small Business Innovative Research

FOR MORE INFORMATION: www.creare.com

Evaluation of Carbon Composite Vessels Fabricated Using Ionic Liquid Epoxies for Cryogenic Liquid Containment

OBJECTIVE: *To extend previous work to fabrication and testing of ionic liquid epoxy (ILE) carbon fiber composite tanks. Successful work will lead to lighter and reusable tanks for cryogenic space applications.*

PROJECT DESCRIPTION

This effort is in alignment with the Center-identified product priority, in-space propulsion with focus on cryogenics. The work will lead to composite cryotanks with improved strength and toughness that will advance a number of NASA objectives.

ACCOMPLISHMENTS

This year's work builds well on last year's accomplishments. We have improved synthesizing the ionic liquid monomer and tested other properties. Three composite overwrap pressure vessels (COPVS) were hydroburst, and six were tested to failure under cryogenic conditions; here, the ILE composite outperformed the commercial epoxy. Similarly, the ILE composite showed ~18% improvement in microstrain to failure under cryogenic conditions; this is reflected in the adjacent fracture micrographs. Currently, we are assessing work to date and preparing manuscripts for technical publication.

BENEFITS

Using storage tanks fabricated from fiber-reinforced polymeric composites to store cryogenic fluids—such as liquid oxygen and liquid hydrogen—is of great interest to NASA. In particular, their high strength-to-weight ratio gives them a clear advantage over strictly aluminum alloy components; we also expect a 20%-40% weight reduction. We can use the established epoxy/metal bonding to join components, and its low vapor pressure makes it an ideal candidate for in-space repairs. It is possible for commercial entities to use tanks that employ the ILE technology for storing liquefied petroleum gases.

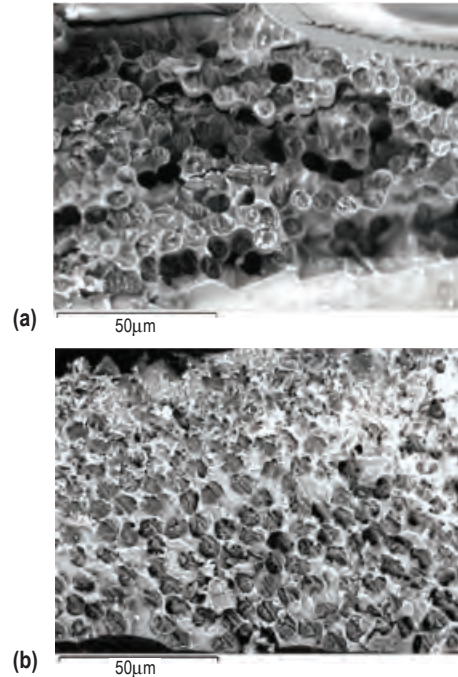

Fracture surfaces of (a) commercial and (b) ILE carbon fiber composites failed under cryogenic (LN_2) conditions. The commercial epoxy exhibits non-wetting and pullout of the fibers. The ILE surface shows plastic deformation of the epoxy and strong binding to the carbon fibers.

PROJECT MANAGER: Richard Grugel

FUNDING ORGANIZATION: Center Innovation Fund

Cryogenic Transfer Line Chillover Correlations in Generalized Fluid System Simulation Program

OBJECTIVE: *To model accurately the chillover of transfer lines by cryogenic propellants in support of cryofluid management.*

PROJECT DESCRIPTION

Transferring cryogenic propellants from storage depots to propellant tanks, or from tanks to engines, requires chilling the transfer lines down from the ambient temperature. Some mass of the propellant must then boil off and is no longer usable. The ability to model chillover is important for accurate propellant usage predictions, critical for in-space operations. Unfortunately, most boiling heat transfer correlations are based on water experiments at constant heat flux and do not necessarily apply to quenching with a cryogenic fluid.

The objective of this research is to develop analytical models of actual chillover tests, conducted by the University of Florida and NASA Glenn Research Center (GRC), using liquid nitrogen and liquid hydrogen, respectively. We have developed boiling heat transfer correlations from the experimental data and coded them as user subroutines in the Generalized Fluid System Simulation Program (GFSSP), a network flow solver NASA developed. Flow rates and temperature profiles are compared to the test data.

ACCOMPLISHMENTS

The University of Florida has built a GFSSP model of its experiment, and we have coded the boiling heat transfer correlations derived from liquid nitrogen experiments as a GFSSP user subroutine. We have developed an algorithm that controls the transition between film, transition, and nucleate boiling regimes. We have compared the model predictions with test data and they show superior agreement compared to earlier models using water-based boiling heat transfer correlations. Subsequently, a GFSSP model of the GRC experiment is in progress.

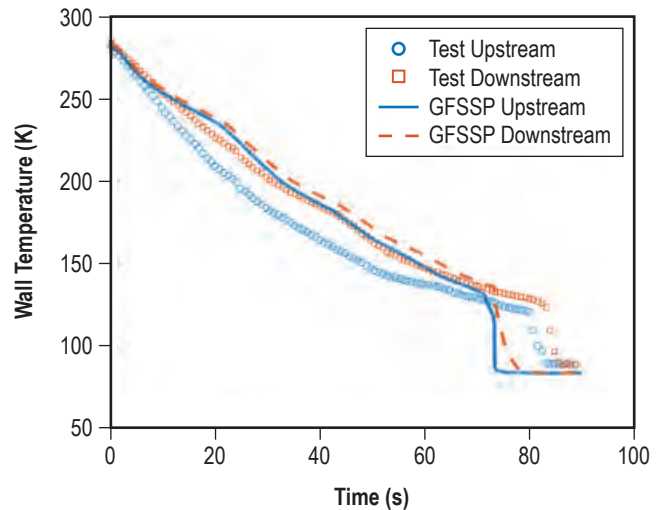

Comparison of GFSSP model predictions of boiling heat transfer to acquired test data.

BENEFITS

Future deep space exploration missions will require multiple launches and in-space assembly and propellant transfer. The ability to predict the amount of propellant that will be lost to chillover is critical. With accurate models of chillover processes, NASA can develop the most efficient procedures for propellant transfer with minimal losses.

PROJECT MANAGERS: André LeClair and Alok Majumdar

PARTNER PRINCIPAL INVESTIGATOR: Dr. Jacob Chung, University of Florida

FUNDING ORGANIZATION: Cooperative Agreement Notice

INDEX BY FUNDING SOURCES

ADVANCED EXPLORATION SYSTEMS

Additive Manufacturing Facility, 82
Autonomous Mission Operations—Expedite the Processing of Experiments to Space Station-2, 30
Carbon Dioxide Removal and Management, 49
Cloud-Based App Design, 64
Delay and Disruption Tolerant Network, 36
Hydrogen Purification for Life Support, 44
In-Space Manufacturing (ISM) Project, 83
FEATURE: In-Space Recycler Technology Demonstration, 72–73
Life Support Systems, 48
MSFC Autonomous Systems and Operations, 31
FEATURE: Near Earth Asteroid Scout, 2–3
Plasma Pyrolysis Technology for Life Support, 45
Trace Contaminant and Particulate Matter Control, 50
Upgrades to the ISS Urine Processor Assembly, 46
Upgrades to the ISS Water Processor Assembly, 47

CENTER INNOVATION FUND

Correlated Electromagnetic Levitation Actuator, 39
Dengue Forecasting Project, 65
Evaluation of Carbon Composite Vessels Fabricated Using Ionic Liquid Epoxies for Cryogenic Liquid Containment, 101
High-Temperature Thermoelectrics, 26
Innovative Fabrication of Nuclear Fuel Material for Nuclear Thermal Rockets, 17
Linear Transformer Drivers, 20
Nuclear Thermal Rocket and Arc Jet Integrated System Modeling, 18
Pulsed Lorentz Accelerator, 19
Small Spacecraft Green Propulsion System Development, 22
Toward In-Space Additive Manufacturing of Thermosets with Embedded Fibers, 90

COOPERATIVE AGREEMENT NOTICE

Concept Analysis Using Natural Language Understanding, 69
Cryogenic Transfer Line Chilldown Correlations in Generalized Fluid System Simulation Program, 102
Development of the Ultrasonic Stir Weld Process, 75
Dual Mode Green Propulsion Proof of Concept, 23

Enabling Fast-Responding Pressure-Sensitive Paint Systems in Blow Down Wind Tunnels, 66
Immersive Decision Making Environment for Mission-Driven Technology Alignment, 67
Optimization of Ultracapacitors, 27
Topic Mapping, 68

GAME CHANGING DEVELOPMENT PROGRAM

Additive Construction with Mobile Emplacement, 54
Nuclear Thermal Propulsion, 13

HUMAN EXPLORATION AND OPERATIONS MISSION DIRECTORATE

3D Printed Augmented Spark Igniter for the RS-25 Engine, 84
Achieving Certification of Additive Manufactured Hardware, 85
Blast Physics Knowledge and Applications, 9
Cold Flow Propulsion Test Complex Pulse Testing, 8
Design, Development, and Testing of a 3D Printed Rocket Engine Turbopump, 86
Modular Tooling Approach for Manufacturing of Large-Scale Launch Vehicle Structures, 77
New Method Applied to Propellant Slosh and Launch Pad Environments Mitigation, 6
Self-Reacting Friction Stir Welding on Space Launch System Core Stage, 76
FEATURE: Series-Bosch Oxygen Recovery for Life Support, 42–43
Wireless Temperature Sensing in the Urine Processor Assembly, 51

INTERNATIONAL SPACE STATION

Carbon Dioxide Removal and Management, 49
Wireless Temperature Sensing in the Urine Processor Assembly, 51

SCIENCE MISSION DIRECTORATE

Advanced UVOIR Mirror Technology Development for Very Large Space Telescopes, 58
Low-Noise Cameras for Suborbital Observations, 60
Mars Ascent Vehicle, 59
FEATURE: Streamlining Access to NASA Data to Address Agricultural and Water Availability Issues, 62–63

SMALL BUSINESS INNOVATIVE RESEARCH

- A High-Efficiency Cryocooler for In-Space Cryogenic Propellant Storage, 100
- Design and Manufacture of Pin Tools for Friction Stir Welding of Temperature-Resistant Materials, 78
- Diamond-based Propulsion Materials, 96
- Fast-Light Enhanced Active Gyroscopes, Accelerometers, and Fiber-Optic Sensors, 38
- Fast-Light Enhanced Fiber Gyroscope, 37
- Loop Heat Pipe Manufacturing for CubeSat Applications, 88
- Manufacturing Advanced Channel Wall Nozzle Rocket Liners, 74
- Metallic Joining to Advanced Ceramic Composites, 79
- Novel Functionally Graded Coating System for Reusable Very High Temperature Applications, 97
- Passive Technology to Improve Criticality Control of Nuclear Thermal Propulsion Reactors, 15
- Selective Laser Ablation and Melting, 93
- Structural Origami Array, 14

SMALL BUSINESS TECHNOLOGY TRANSFER

- An Additive Manufacturing Technique for the Production of Electronic Circuits, 89
- Empirical Optimization of Additive Manufacturing, 87

SPACE TECHNOLOGY MISSION DIRECTORATE, SMALL SPACECRAFT TECHNOLOGY PROGRAM

- Carbon Dioxide Removal and Management, 49
- FEATURE:* Propellantless Attitude Control of Solar Sails Using Reflective Control Devices, 34–35
- The Iodine Satellite, 16

TECHNOLOGY DEMONSTRATION MISSIONS

- Integrated Vehicle Fluids, 12

TECHNOLOGY INVESTMENT PROGRAM

- Bimetallic Additively Manufactured Main Combustion Chambers, 91
- Embedded Wireless Strain Sensors for Rapid Characterization of Structural Health, 94
- Ionic Liquid Metals and Oxygen Extraction in Microgravity — A Prelude to Asteroid Mining, 55
- Optical Diagnostic Technology for Generating Plume-Induced Environments, 7
- Pulsed Plasma Thruster for CubeSats, 21
- Small Spacecraft Green Propulsion System Development, 22
- Space Environmental Effects on Additively Manufactured Parts, 92

U.S. ARMY CORPS OF ENGINEERS

- Additive Construction with Mobile Emplacement, 54

REPORT DOCUMENTATION PAGE

Form Approved
OMB No. 0704-0188

The public reporting burden for this collection of information is estimated to average 1 hour per response, including the time for reviewing instructions, searching existing data sources, gathering and maintaining the data needed, and completing and reviewing the collection of information. Send comments regarding this burden estimate or any other aspect of this collection of information, including suggestions for reducing this burden, to Department of Defense, Washington Headquarters Services, Directorate for Information Operation and Reports (0704-0188), 1215 Jefferson Davis Highway, Suite 1204, Arlington, VA 22202-4302. Respondents should be aware that notwithstanding any other provision of law, no person shall be subject to any penalty for failing to comply with a collection of information if it does not display a currently valid OMB control number.

PLEASE DO NOT RETURN YOUR FORM TO THE ABOVE ADDRESS.

| | | | | | | | | |
|--|-----------------------------|------------------------------|---|--|---------------------------------------|---|---|--|
| 1. REPORT DATE (DD-MM-YYYY) 01-04-2017 | | | 2. REPORT TYPE Technical Memorandum | | | 3. DATES COVERED (From - To) October 2015–October 2016 | | |
| 4. TITLE AND SUBTITLE Marshall Space Flight Center Research and Technology Report 2016 | | | | | | 5a. CONTRACT NUMBER | | |
| 6. AUTHOR(S) M.L. Tinker, M.B. Abney, D.W. Reynolds, and H.C. Morris, Compilers | | | | | | 5b. GRANT NUMBER | | |
| | | | | | | 5c. PROGRAM ELEMENT NUMBER | | |
| | | | | | | 5d. PROJECT NUMBER | | |
| 7. PERFORMING ORGANIZATION NAME(S) AND ADDRESS(ES) George C. Marshall Space Flight Center Huntsville, AL 35812 | | | | | | 5e. TASK NUMBER | | |
| | | | | | | 5f. WORK UNIT NUMBER | | |
| | | | | | | 8. PERFORMING ORGANIZATION REPORT NUMBER M-1427 | | |
| 9. SPONSORING/MONITORING AGENCY NAME(S) AND ADDRESS(ES) National Aeronautics and Space Administration Washington, DC 20546-0001 | | | | | | 10. SPONSORING/MONITOR'S ACRONYM(S) NASA | | |
| | | | | | | 11. SPONSORING/MONITORING REPORT NUMBER NASA/TM—2017-219502 | | |
| 12. DISTRIBUTION/AVAILABILITY STATEMENT Unclassified-Unlimited Subject Category 12 Availability: NASA STI Information Desk (757-864-9658) | | | | | | | | |
| 13. SUPPLEMENTARY NOTES Prepared by the Office of the Director, Center Chief Technologist | | | | | | | | |
| 14. ABSTRACT Many of NASA's missions would not be possible if it were not for the investments made in research advancements and technology development efforts. The technologies developed at Marshall Space Flight Center contribute to NASA's strategic array of missions through technology development and accomplishments. The scientists, researchers, and technologists of Marshall Space Flight Center who are working these enabling technology efforts are facilitating NASA's ability to fulfill the ambitious goals of innovation, exploration, and discovery. | | | | | | | | |
| 15. SUBJECT TERMS MSFC Research and Technology Report 2015, engineering, science, technology | | | | | | | | |
| 16. SECURITY CLASSIFICATION OF: | | | 17. LIMITATION OF ABSTRACT UU | | 18. NUMBER OF PAGES 118 | | 19a. NAME OF RESPONSIBLE PERSON STI Help Desk at email: help@sti.nasa.gov | |
| a. REPORT U | b. ABSTRACT U | c. THIS PAGE U | | | | | 19b. TELEPHONE NUMBER (Include area code) STI Help Desk at: 757-864-9658 | |



National Aeronautics and Space Administration
George C. Marshall Space Flight Center
Huntsville, AL 35812
www.nasa.gov/marshall

www.nasa.gov