

Scientific Ballooning Technologies Workshop

Balloon Thermal Model Design Parameters and Sensitivities

Doug Ferguson, Orbital ATK - Beltsville

May 18, 2017



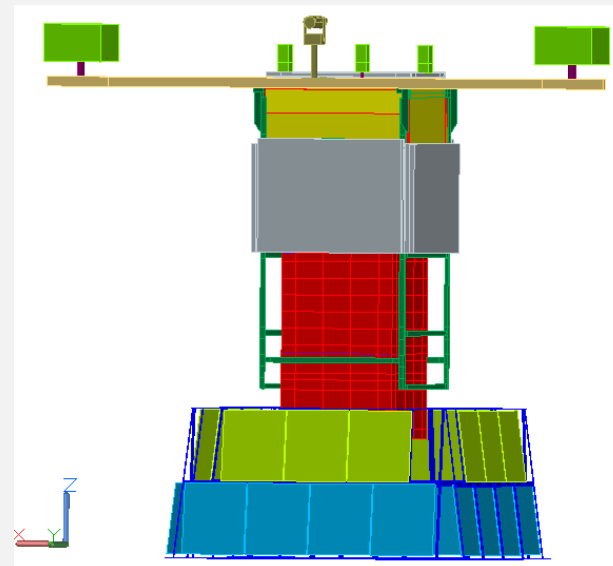

- The EUSO experiment launched in April 2017 from Wanaka, New Zealand.
- The UNAM and CSBF thermal staff worked together on the mission thermal design and analysis.
 - UNAM developed a science thermal model.
 - CSBF modeled the remaining mission hardware.
 - The teams shared model results and data to optimize the thermal design and to accurately and conservatively model the heat exchange between the two design spaces.

Thermal Model

- Thermal Desktop version 5.7 was used to create the CSBF EUSO model.
- The model has over 6,000 nodes, and includes the SIP, solar arrays, structure, balloon, flight train, and a reduced Science payload.
 - UNAM provided CSBF with a detailed Science thermal model which was gradually reduced.
 - Most component and support structure surfaces are painted white to mitigate maximum temperature predictions in hot case scenarios.
 - Styrofoam insulation surrounds the SIP shield; its outer surfaces are aluminized Mylar.

Science payload

CSBF SIP
Shield
(Styrofoam
insulation)

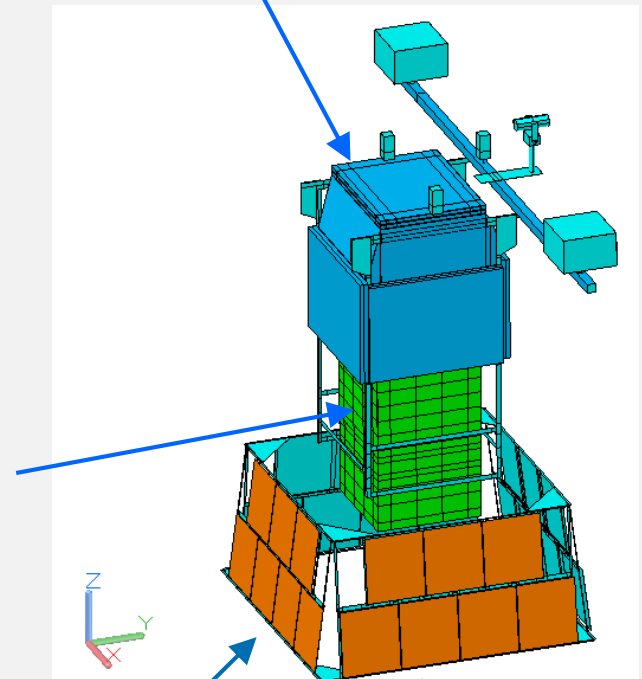

Solar Arrays

- Thermal Desktop version 5.7 was used to create the CSBF EUSO model.
- The model has over 6,000 nodes, and includes the SIP, solar arrays, structure, balloon, flight train, and a reduced Science payload.
 - UNAM provided CSBF with a detailed Science thermal model which was gradually reduced.
- Inside the gondola structure, plywood separates the CSBF hardware from the Science payload.
- This presentation will focus on the PCU, a component internal to the SIP frame.
 - 15 W heat load
 - -40 to 70°C temperature requirements
 - Mounted to the SIP frame
 - Painted white

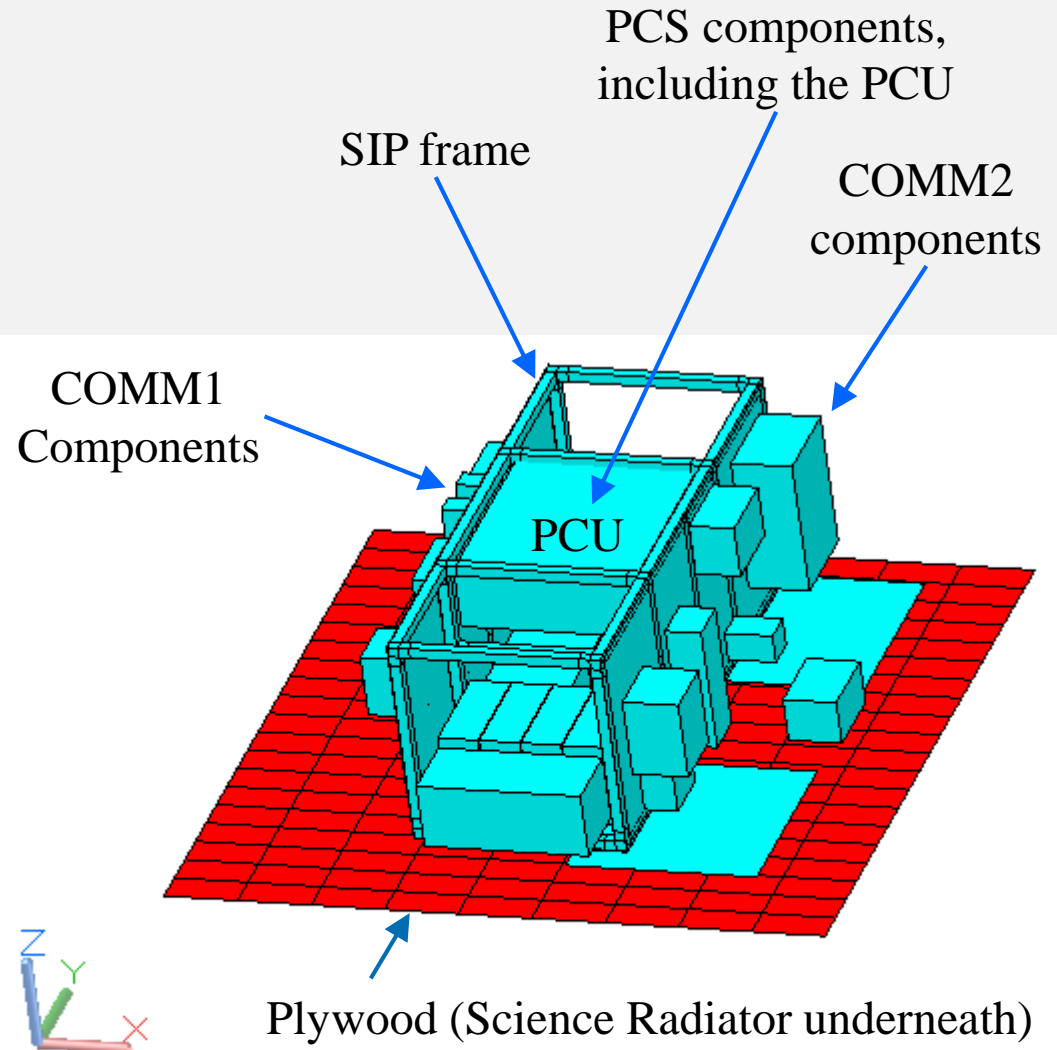

SIP shield and surrounding foam insulation not shown

- Environmental parameters were discussed with UNAM, and changed based on review of the Top-of-Atmosphere database. The agreed parameters used in both models are the following:

| | Cold Case Value | Hot Case Value |
|-----------------------------|----------------------|-----------------------|
| Solar Flux | 1304 | 1368 W/m ² |
| Albedo Factor | 0.635 | 0.107 |
| Earth IR/Planet Flux | 177 W/m ² | 288 W/m ² |
| Latitude | 65°S | 44.5°S |
| Altitude at Float | 35 km | 35 km |

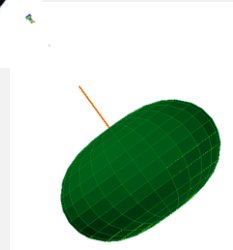
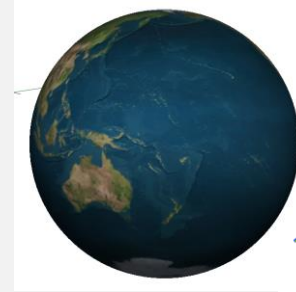

- Design cases with alternative latitudes were evaluated but were found not to be driving cases. These cases were a cold case at 55°S and a hot case at 25°S.
- Based on an internet search of historical temperature data, initial temperatures were set at 3°C for cold case analysis and 26°C for hot case analysis.

- The baseline hot case was re-run multiple times, with one model parameter variation in each run as follows.
 1. (Coatings) Aluminum tape covered the white paint on one side of the four corner panels on the gondola near the SIP (lowering its emissivity to 0.10 from 0.88).
 2. (Coatings) Aluminum tape covered the aluminized Mylar on the $\pm X$ sides of the SIP shield (lowering its emissivity to 0.10 from 0.84).
 3. (Environment) The albedo factor was raised by 0.1 (to 0.207 from 0.107).
 4. (Environment) The Earth IR flux value was increased by 100 W/m² (to 388 from 288).
 5. (Environment) The solar constant was increased by 100 W/m² (to 1468 from 1368).
 6. (Heat loads) The PCU heat load was increased by 10 Watts (to 25 from 15).
 7. (Mission) The launch window opened 60 days earlier (to Dec. 31st from Feb. 28th).
 8. (Orbit) The latitude at float was altered to 0° (from 45°S).
- The hot case was run as a steady state at float (35 km) to facilitate direct comparison of PCU temperature predictions.
- *Four of the above analysis runs led to PCU temperatures within 1°C of the baseline; four led to temperature differences of 3°C or greater.*

- In the baseline analysis case, the PCU temperature is 16.36°C. The following PCU temperatures were determined from the following parametric analysis cases. (Changes <1°C are listed in blue, changes of >3°C are listed in red.)

| | | |
|--|---------|------------------|
| 1. Aluminum tape on corner panels: | 16.63°C | |
| 2. Aluminum tape on the SIP shield: | | 23.49°C |
| 3. Albedo factor was raised by 0.1: | 17.18°C | |
| 4. Earth IR flux raised by 100 W/m ² : | | 22.27°C |
| 5. Solar constant raised by 100 W/m ² : | 17.22°C | |
| 6. PCU heat load was increased 10W: | | 21.77°C |
| 7. Launch on Dec. 31 st : | 17.26°C | |
| 8. Float at Equator: | | 11.62°C (colder) |

- The EUSO SIP thermal design is more sensitive to the IR portion of the environmental heat load than the UV portion (direct solar and albedo).
 - The use of low α /high ϵ surface treatments creates this tendency.
- Thermal dissipations are key design parameters.
 - Always check power consumption thermal dissipation...is all the lost electrical power converted to thermal energy?
 - Modeling a range of dissipations (low = cold case, high = hot case) conservatively addresses heat load uncertainties.
- The SIP shield surface treatments are the most important coating decisions.
 - Minor tweaks to the gondola design such as aluminum tape over white paint in small areas can be an effective last-minute design improvement.
- SIP temperatures show only modest (hot side) sensitivity to launch date variability.
- Disclaimer: Some of these lessons learned are specific to the EUSO SIP and may not apply to other missions.