



# Ikhana UAS

## Overview



Mauricio Rivas

Ikhana Project Manager

May 2017



# NASA's Ikhana UAS

- “Ikhana” is a Native American, Choctaw, word meaning “intelligent, conscious or aware”.
- Ikhana is an MQ-9 variant used as an airborne platform for:
  - › Medium Altitude Long Endurance (MALE) Earth observation and atmospheric sampling science missions world-wide
  - › Development and demonstration of technologies that improve the capability of unmanned aircraft to conduct science data collection.
  - › Development and demonstration of technologies that improve capability, reliability, and safety of manned and unmanned aircraft.



# Ikhana's Projects – Past and Present

- Fiber Optic Wing Sensing System (FOWSS): FOWSS first airborne application – 2007
- **Western States Fire Missions (WSFM): Delivered infrared images in near real-time to fire fighters – 2007 to 2009**
- **Flight test of US Army's Intelligence and Information Warfare Directorate's (I2WD) Tactical Reconnaissance and Counter-concealment Enabled Radar (TRACER) Pod – 2010-2011**
- US Air Force Test Pilot School Curriculum Support – 2011
- FAA Familiarization – 2012
- Automatic Dependent Surveillance-Broadcast (ADS-B) system system flight test: Supporting NASA's Unmanned Aircraft Systems Integration in the National Air Space (UAS-NAS) Project – 2012
- **Developed Generic Science Pod (GSP) to support NASA's Marginal Ice Zone Operational Program EXperiment (MIZOPEX) – 2012 (Ikhana didn't support mission)**
- DoD Flight Test Support – 2013
- **Hawaii Deployment – in partnership with US Navy 3<sup>rd</sup> Fleet, General Atomics – Aeronautical Systems, Inc. (GA-ASI) & the National Oceanic and Atmospheric Administration (NOAA) – 2014**
- Autonomous Collision Avoidance System for UAS (ACAS Xu) flight test in support of NASA's UAS-NAS Project and in partnership with FAA, GA-ASI, and Honeywell – 2014-2015
- **Orion Exploration Flight Test 1 (EFT-1) Support – 2014**
- **Supporting NASA's UAS-NAS Project with Flight Test 3 (FT-3) and Flight Test 4 (FT-4) – Continued Flight Test of Detect And Avoid (DAA) capabilities to inform Minimum Operating Performance Standards (MOPS) development – 2015-2016**
- Supporting NASA's UAS-NAS Project with ACAS Xu Flight Test 2 in partnership with FAA, GA-ASI, Honeywell, and Aviation Communications & Surveillance Systems (ACSS) – 2017



# Ikhana's Western States Fire Missions (WSFM)

- Air Space Integration:

- › Developed internal approach to apply for FAA Certificate of Authorization (COA)
- › Obtain COA that enabled quick response to support fire surveillance over Western States







## Ikhana's WSFM (cont.)

- Demonstrate capabilities of UAS to overfly and collect sensor data on widespread fires throughout Western US.
- Demonstrate long-endurance mission capabilities (20-hours+).
- Image multiple fires (greater than 4 fires per mission), to showcase extendable mission configuration and ability to either linger over key fires or station over disparate regional fires.
- Demonstrate new UAV-compatible, autonomous sensor for improved thermal characterization of fires.
- Provide automated, on-board, terrain and geo-rectified sensor imagery over the horizon SATCOM links to national fire personnel and Incident commanders.
- Deliver real-time imagery (within 10-minutes of acquisition).
- Demonstrate capabilities of technologies like GoogleEarth to display mission-critical sensor data, coincident with other pertinent data elements to facilitate information processing (WX data, ground asset data, other satellite data, R/T video, flight track info, etc).



# Ikhana's WSFM (cont.): Reconfigurable Flight Test "Fire Pod"

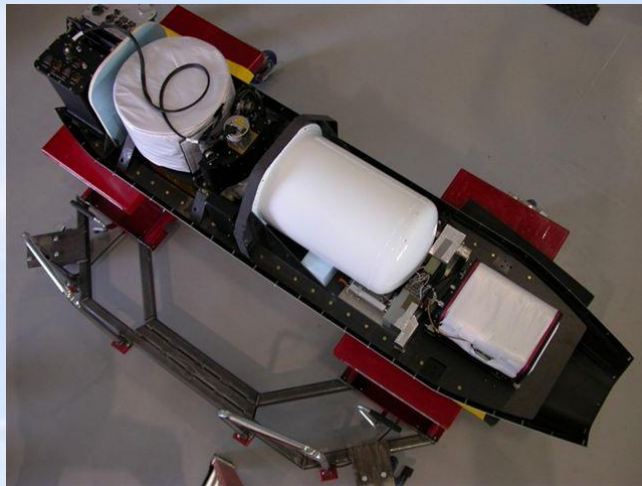
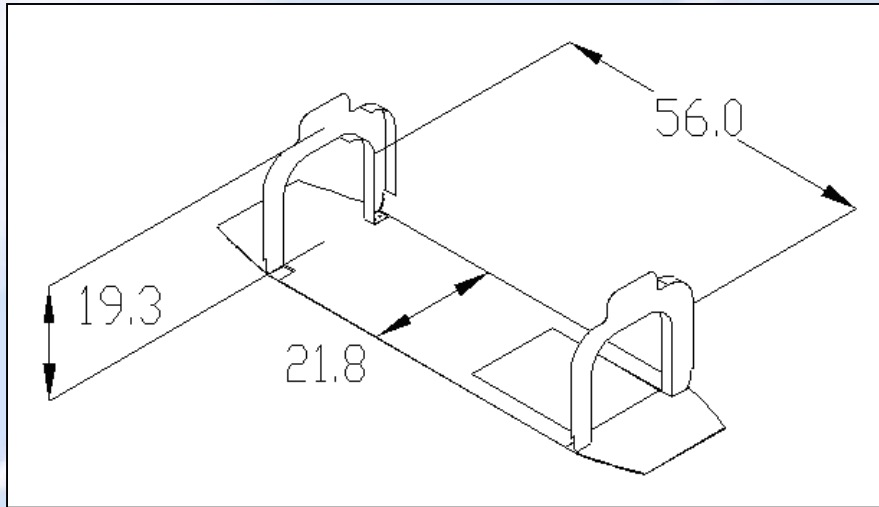

AMS Sensor Components on Pod Tray



Tray Prepared for Upload



# Ikhana's WSFM (cont.)

## ■ Concept of Operations

- › Chase aircraft required below 18k in the U.S. National Airspace (NAS)
- › Air traffic control (ATC) used for collision avoidance above 18,000 ft
- › NASA AFRC uses restricted airspace to climb to cruise altitude before exiting into the NAS
- › Since Ikhana not cleared for Reduced Vertical Separation Minima (RVSM), operations are limited to 18,000 ft to FL 290 or above FL 410
- › Transponder and radio communication required

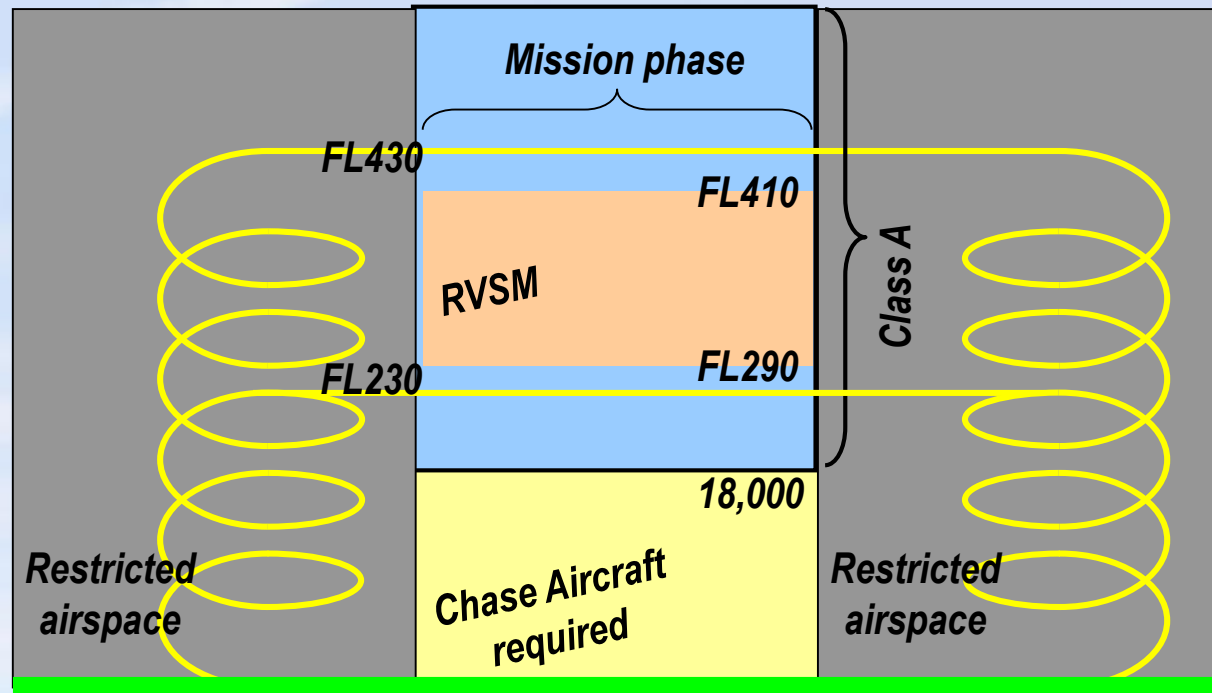





# Ikhana's WSFM (cont.)

## Range Safety Protection Zones

**KEEP-OUT  
ZONES**

 **NOMINAL  
AIRCRAFT**

 **UNHEALTHY  
AIRCRAFT**

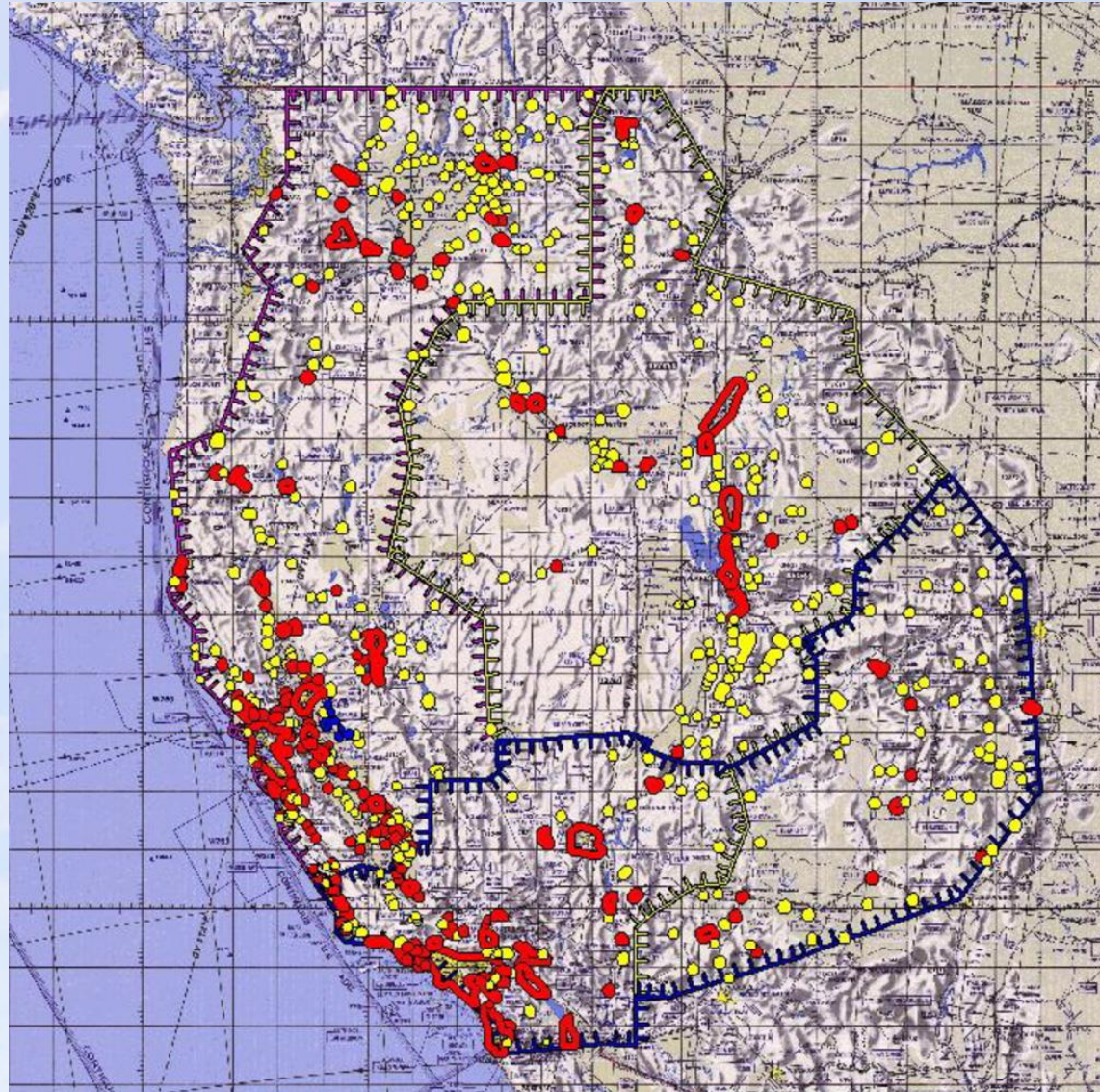





## Ikhana's WSFM (cont.)

- Remain within 75nm of 'backbone' route
- Point to point flight plan
- 3 business day mission notification to FAA
- No flight in to forecasted "moderate or severe" turbulence
- No flight in area where convective Significant Meteorological (SIGMET) has been issued
- No flight in area of known or forecast icing
- Lost link procedure agreed to
- No flight in area of affected by GPS testing, solar storms or Receiver Autonomous Integrity Monitoring (RAIM) outages





# Ikhana's WSFM (cont.)

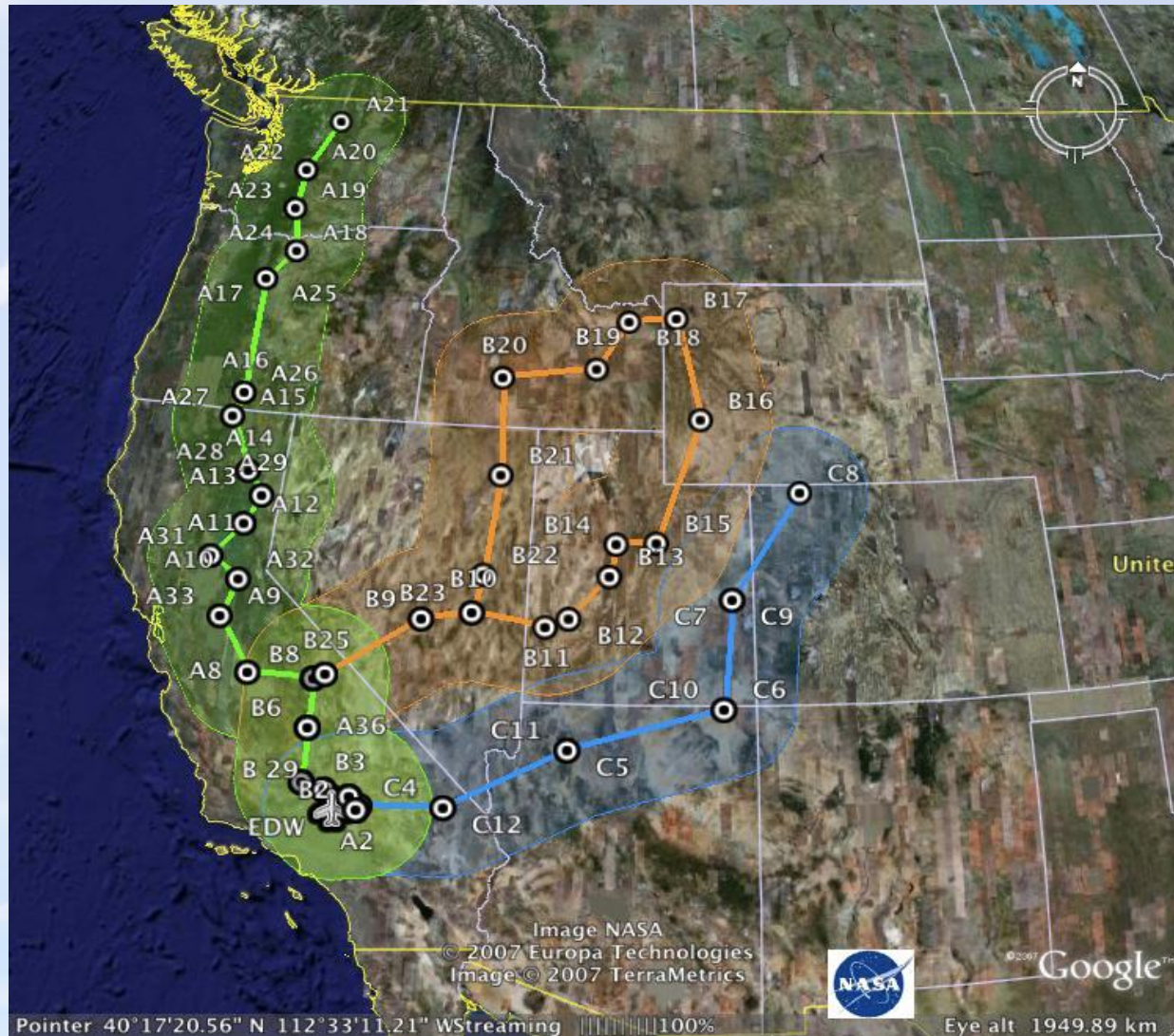







Edwards AFB

IKHANA

~1350 nmi route  
~9 hours



Ranch, Buckweed

Grass Valley, Slide

Los Angeles

Riverside

Anaheim  
Santa Ana

Santiago

Long Beach

Rice

Ammo

Poomacha

Witch

Harris

Image NASA San Diego

© 2007 Europa Technologies  
Image © 2007 DigitalGlobe



©2007 Google





# Ikhana's WSFM (cont.)

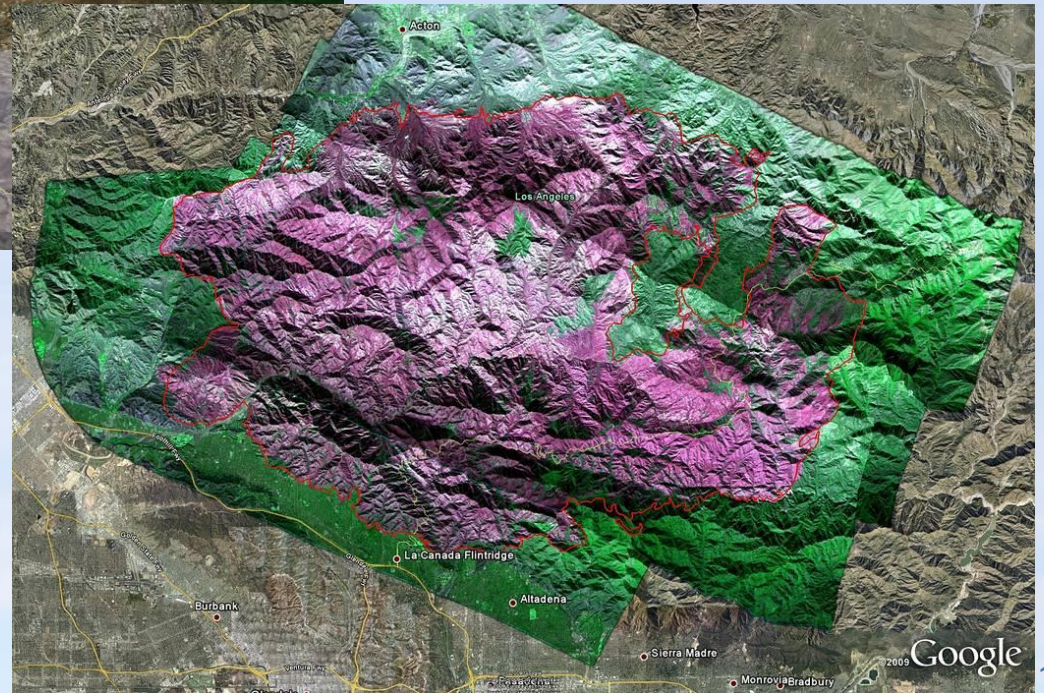
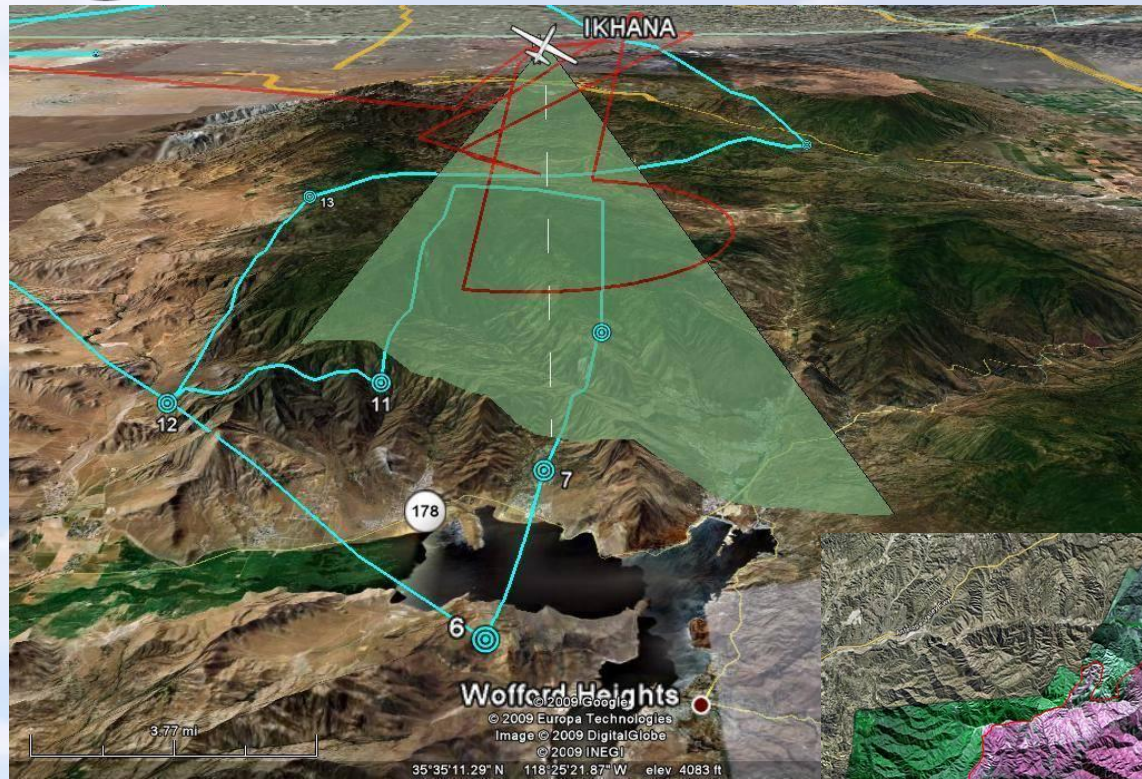



# Ikhana TRACER Support

- Air Space Integration:
  - › Obtained FAA COA to transit between Edwards and Yuma ranges







## Ikhana TRACER Support (cont.)

- I2WD requested Ikhana support in 2009 to demonstrate UAS TRACER capability
- No Sky Warrior/Gray Eagle UAS were available
- An integrated I2WD, Lockheed-Martin & NASA team worked hand in glove to complete testing
- About 20 flights with the TRACER Pod were accomplished
- Flight test took place at the Yuma range



# Ikhana TRACER Support





# MIZOPEX Science Mission Overview

- Air Space Integration:
  - › Unable to perform the mission – primarily due to Ikhana schedule constraints
    - Mission move of mission from Ikhana to SIERRA
  - › Complicated CONOPS – ran out of time to develop and demonstrate safe approach to perform missions







# MIZOPEX Science Mission Overview (cont.)

- An interdisciplinary effort of oceanographers, cryospheric scientists, aeronautical engineers, UAS operators and database/data systems experts
- Questions to be answered:
  - How much is the warming of the MIZ in the Arctic Ocean under or over estimated by satellite measurements?
  - How does this warming affect sea ice melt in the MIZ?
  - Can we better characterize sea ice survival rates in the transition zone between open ocean and permanent ice through improved data input to ice forecasting and climate models?

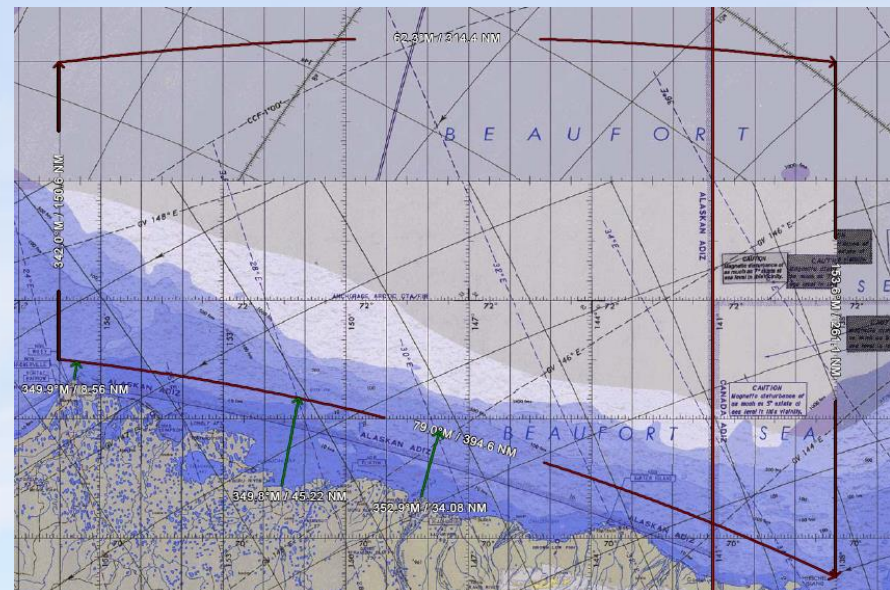



# MIZOPEX Mission Objectives

## ■ Science

- Quantify the variability of sea surface **temperature** and **salinity**, **ice conditions** in and near the marginal ice zone
- Determine the accuracy of satellite-derived data
- Investigate how well measurements represent subsurface temperatures
- Assess ice-ocean interactions
- Identify variations in **ice thickness** and **surface characteristics**
- Investigate what types of ice survive summer melt

## ■ Aeronautical:

- Demonstrate coordinated operation of multiple classes of UAS
- Long-duration, repeated UAS missions in the NAS
- Deployment of unique combinations of remote sensing instrumentation

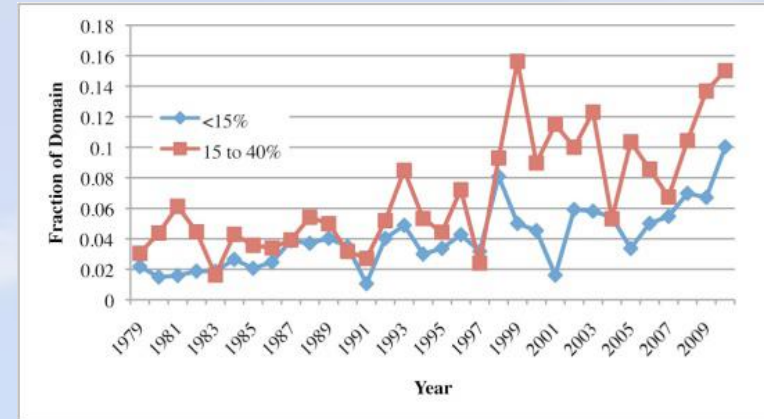





# MIZOPEX Ikhana Routes & Mitigations

- 3 Routes between R-2205 and the Science Area
  - › Barter Island Entry/Exit
    - Most eastern route
    - Basically the route approved for the NASA Global Hawk
  - › Deadhorse Entry/Exit
    - Central route
  - › Barrow Entry/Exit
    - Most western route
- Entry and Exit route will be the most direct routing to the specific area of interest within the Science Area and may differ
- Class A airspace below RVSM
  - › FL280 north to Science Area
  - › FL270 south from Science Area
  - › Or as directed by ATC
- Approximately 2 hours in transit

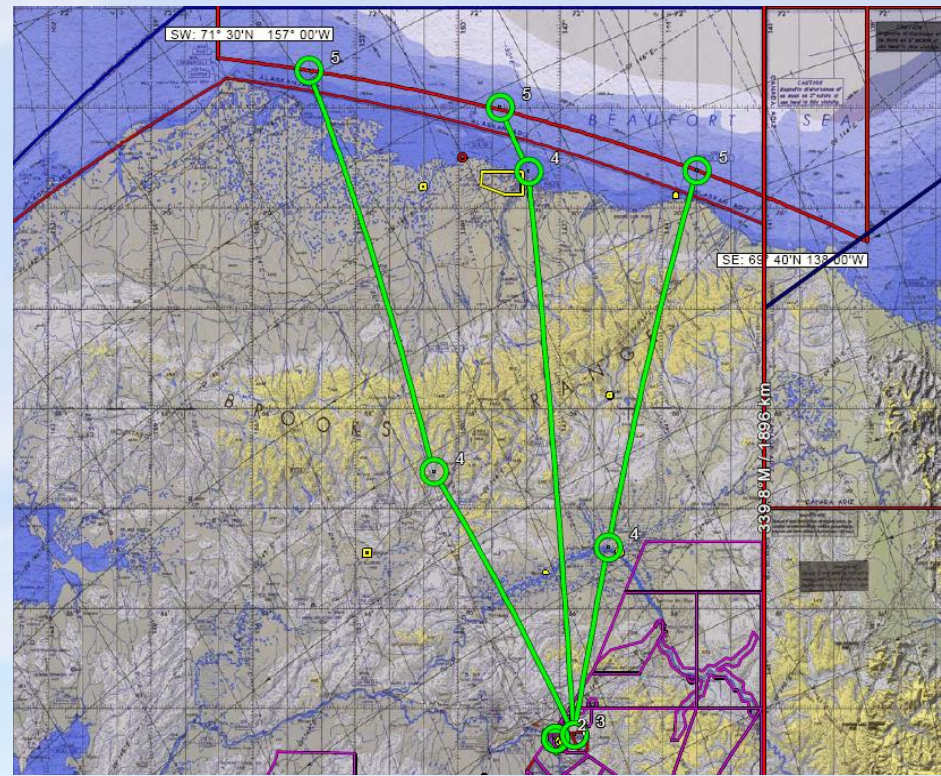
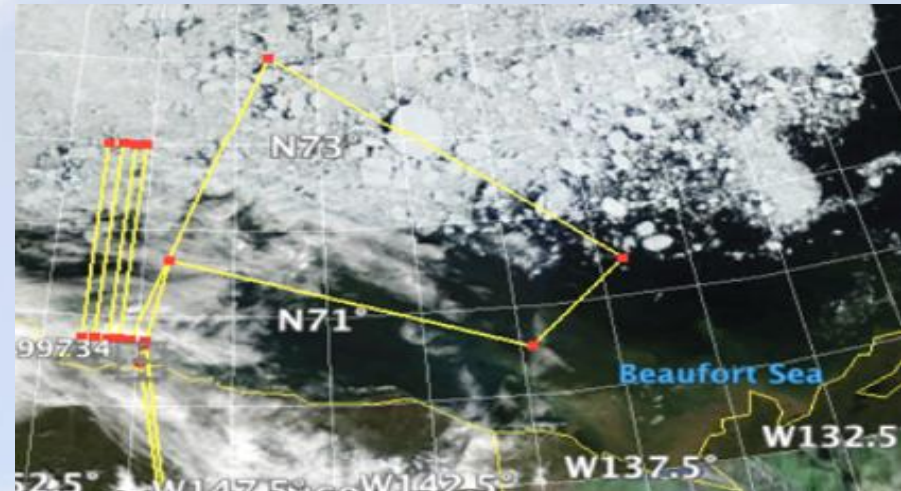



# Ikhana's Hawaii Deployment 2014

- Air Space Integration:
  - Allowed to fly in coordination with RIMPAC exercise without airborne chase
  - Allowed to use dedicated personnel on ground radar console as ground based observer
  - Only required airborne chase for a portion of air space







# Ikhana's Hawaii Deployment 2014

## Objectives accomplished:

- Performed Ikhana's first deployment
- Developed Ikhana specific deployment features
- Demonstrated Ikhana capabilities to support science missions





# Ikhana's Hawaii Deployment 2014 (cont.)

## Ikhana Leaving San Diego





# Ikhana's Hawaii Deployment 2014 (cont.)

## Ikhana in Hawaii







## Ikhana's Hawaii Deployment 2014 (cont.)

### Missions Included:

- Humanitarian Aid & Disaster Relief Training
- Situational Awareness
- Photo Exercise
- Demonstrated Science Observation Missions to the Papahānaumokuākea Marine National Monument
- Sensor System Integration
- Alternate C2 Demonstration

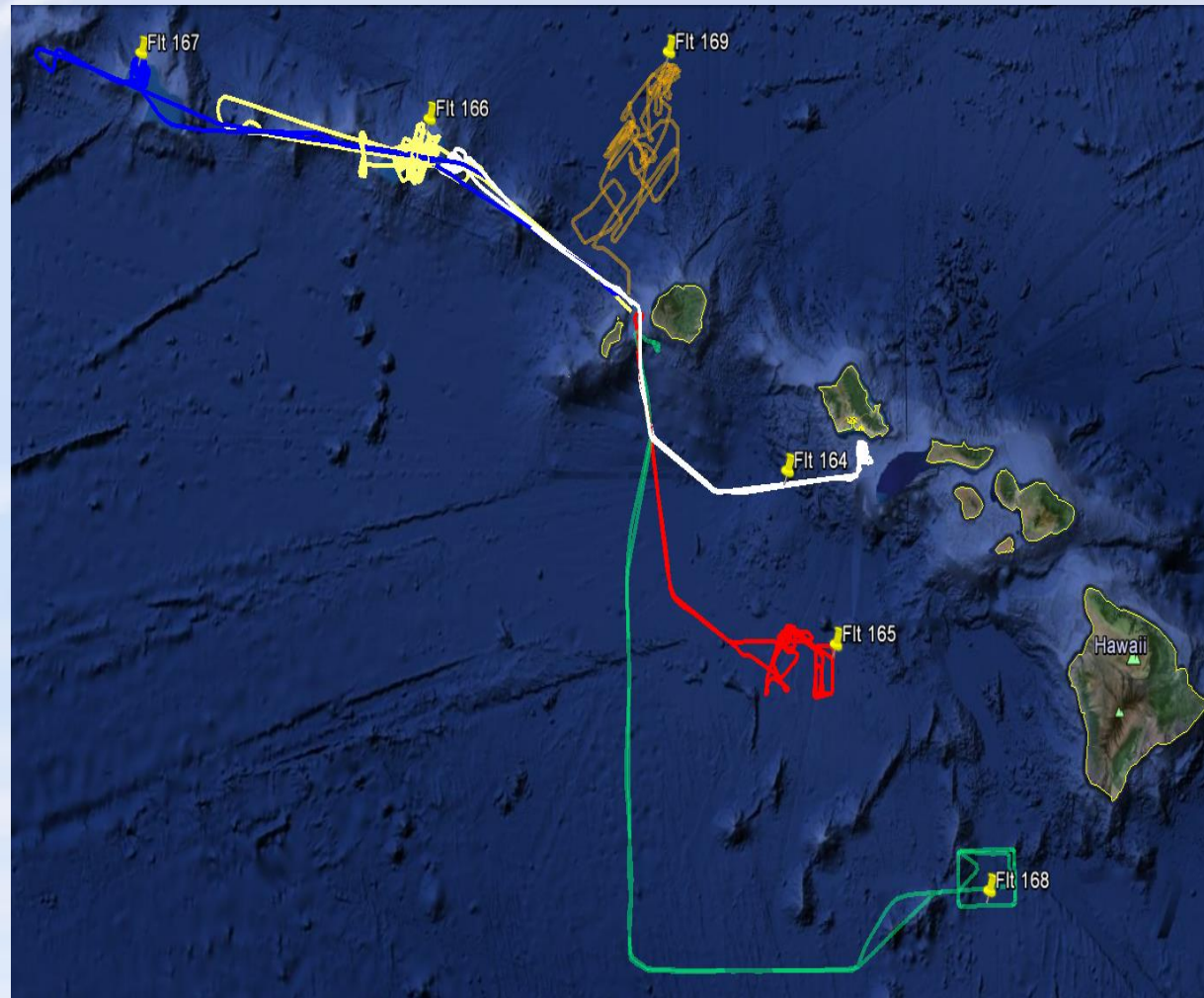





# Ikhana's Hawaii Deployment 2014 (cont.)

## Papahānaumokuākea Marine National Monument

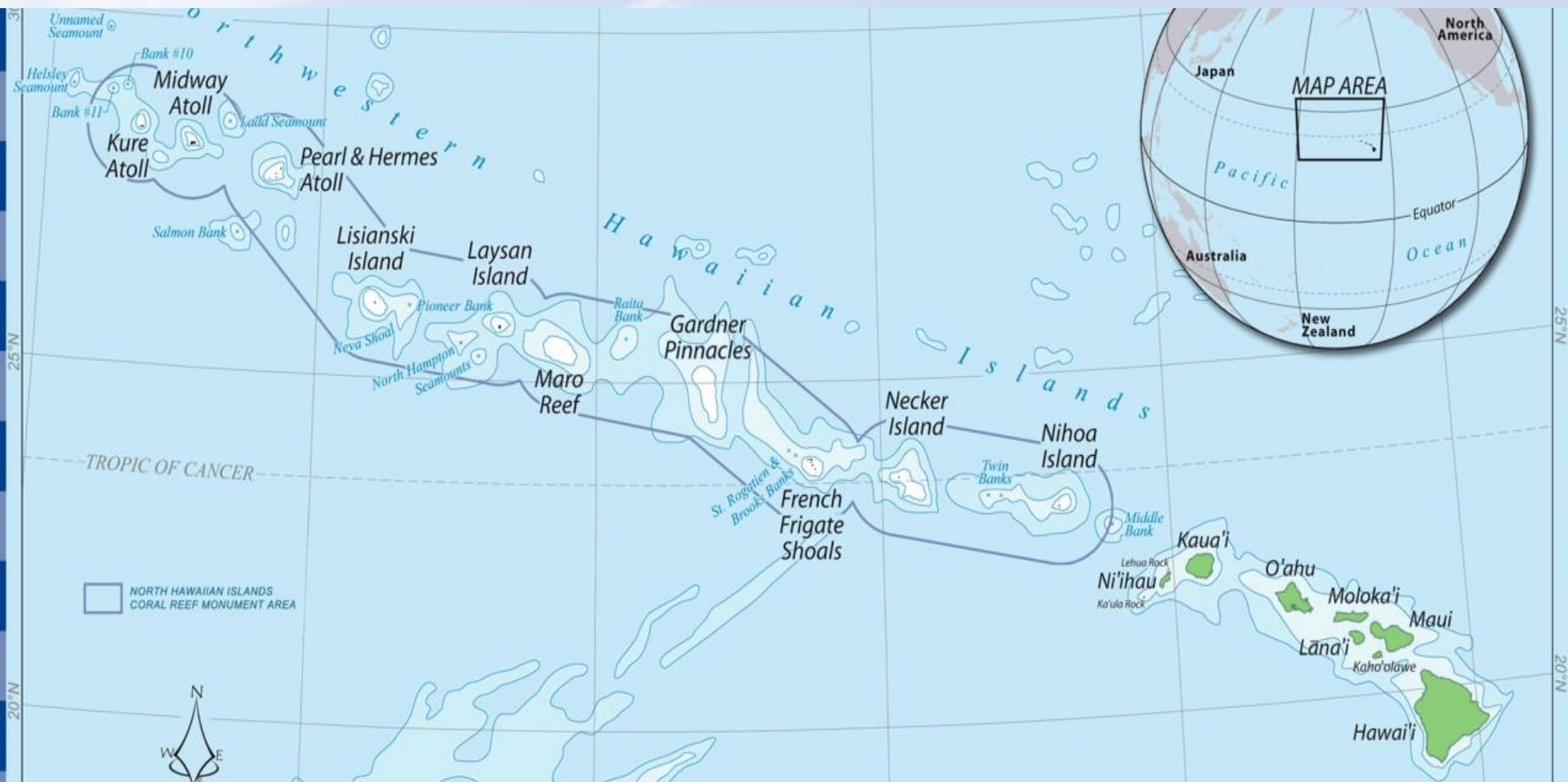







# Ikhana's Support of Orion Splashdown

- Air Space Integration:
  - Modified existing COA to access Pacific and transit out of Warning Area
  - Coordinated operation over Mazatlan controlled air space
  - Coordinated operation with multiple aircraft supporting Orion recovery





## Ikhana's Support of Orion Splashdown (cont.)

- In FY15, NASA AFRC's Ikhana UAS supported NASA HQ PAO coverage of the Orion Exploration Flight Test 1 (EFT-1) splashdown event off the West Coast of Baja California.
- The primary objective Ikhana was given was to observe the Orion capsule descent under the main parachutes. Secondary objectives included early acquisition and post-splashdown coverage. Ikhana was able to acquire Orion on IR imaging as it re-entered the atmosphere and provided live coverage of the successful descent. Originally only limited coverage of recovery was requested, but we planned mission to provide as much time as we could, so when the request to extend our coverage of the recovery was made we were able to support.
- Though there was not a lot of time to prepare and EFT-1 took place in the middle of the ACAS-Xu flight series, the Ikhana team was able to obtain support from the State Department to operate in international air space controlled by Mexico's Mazatlan FIR, and negotiated a Pen and Ink route change to an existing Certificate of Waiver/Authorization (COA) from the FAA making our participation possible.





# Ikhana's Support of Orion Splashdown (cont.)

Objective accomplished:

- Demonstrated EO/IR capability to support launch/re-entry missions
  - Captured Orion on infrared camera level with Ikhana at ~ 27,000 ft
  - Followed Orion to splashdown; descent took about 5.5 minutes

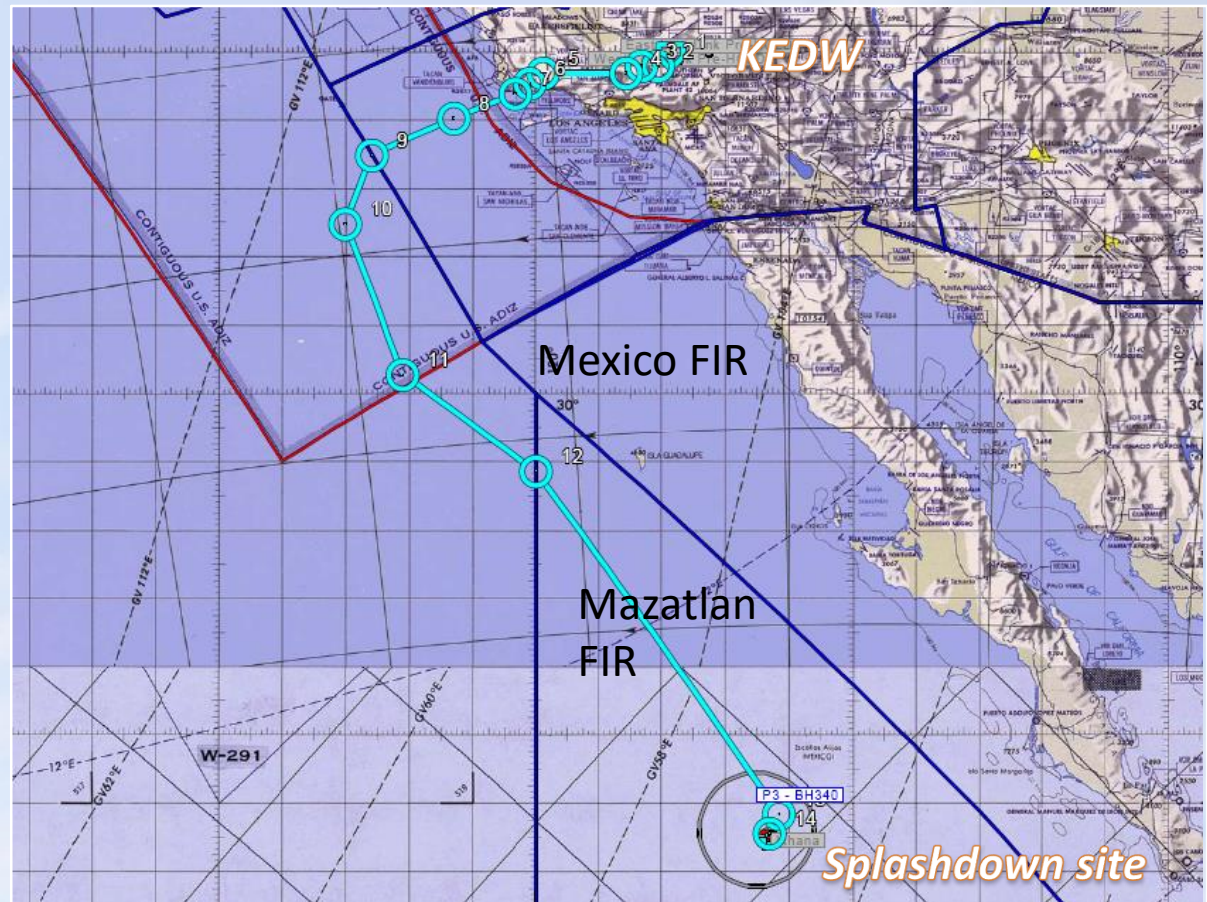

- Ikhana Orion EFT-1 Timeline
- Pilot Prep (T-2.0)
  - Crew Brief (T-1.5)
  - Step (T-1.0)
  - Take-off from KEDW (T-0.0)
  - Arrive at splashdown site & loiter start (T+5.5)
  - RTB (T+10.5)
  - Land @ KEDW (T+16.0)







# Overview of NASA's UAS in the NAS Project

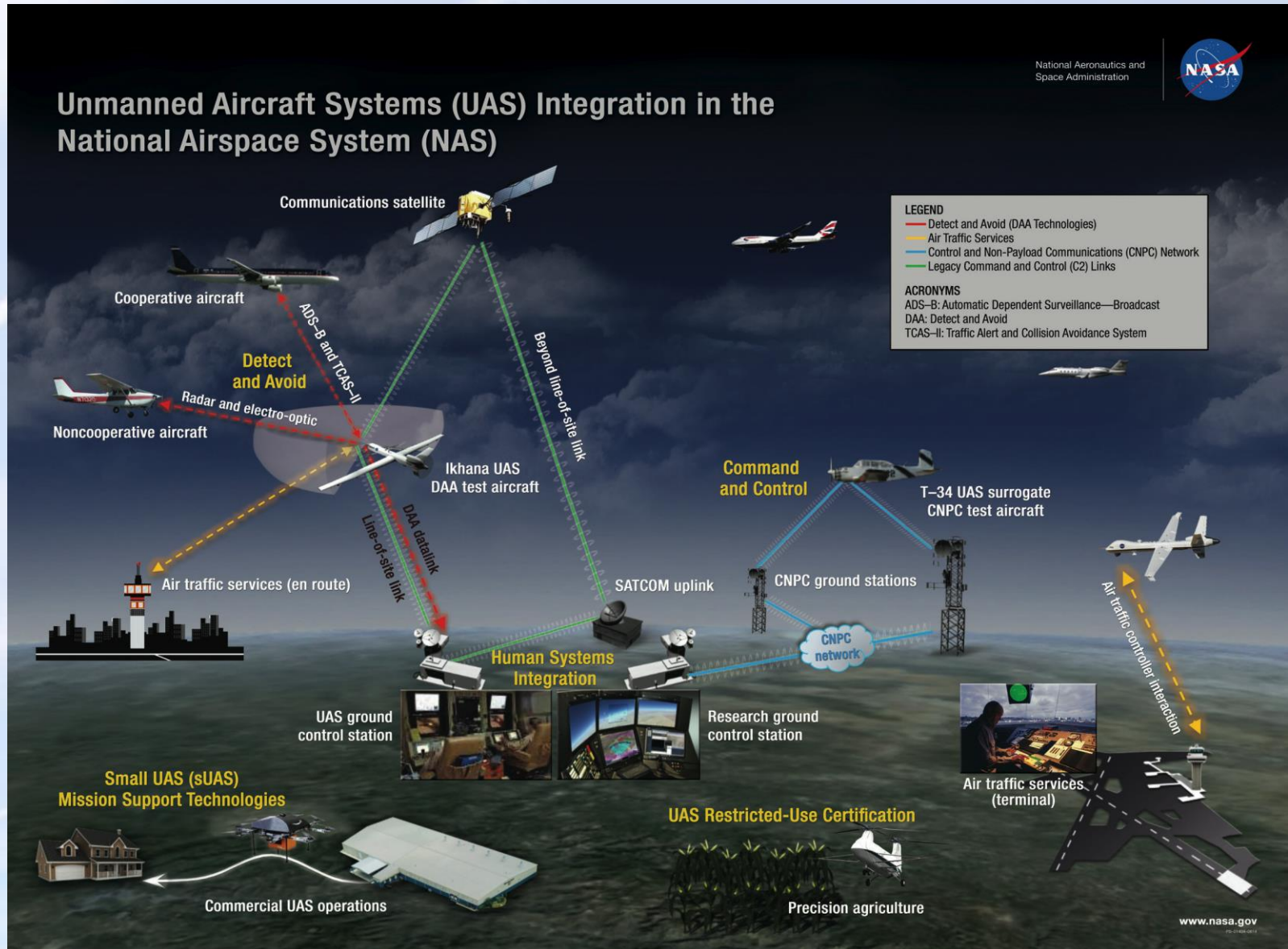



# UAS in the NAS – ACAS X<sub>u</sub>

## Objective accomplished:

- Flight Test of Airborne Collision Avoidance System for UAS (ACAS Xu)



Ikhana ACAS Xu Configuration

- Performed in partnership with FAA
- Demonstrated sensor & flight control system integration
- Completed >100 hours of flight test, including UAS v. UAS encounters
- Incorporated variety of sensors:
  - ADS-B
  - TCAS
  - Air To Air Radar (ATAR)





## UAS in the NAS – Flight Test 3

- Objectives Accomplished:
  - Informed Development of Minimum Operational Performance Standards (MOPS)
  
- Integrated and flight tested upgraded ATAR
- Data collection to advance MOPS development
- Airborne Research Processor (ARP) acquisition





## FT-4 Top Level Goals and Objectives

### Top Level Research Goal:

- Conduct flight tests in a relevant environment to contribute to the validation of the final Phase 1 DAA

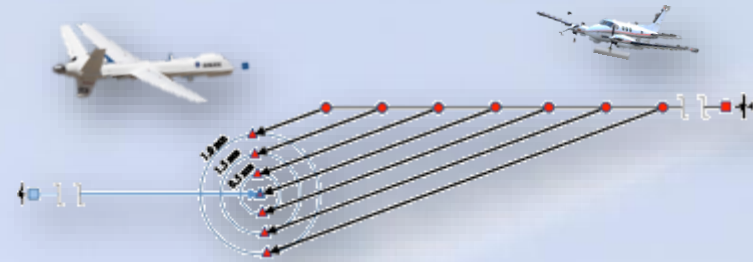

### Top Level Research Objectives:

- Validate DAA requirements in stressing cases that drive MOPS requirements
- Validate TCAS/DAA alerting and guidance interoperability concept in the presence of realistic sensor, tracking and navigational errors and in multiple-intruder encounters against both cooperative and non-cooperative intruders
- Validate ‘Well Clear Recovery’ guidance in the presence of realistic sensor, tracking and navigational errors
- Validate DAA alerting and guidance requirements in the presence of realistic sensor, tracking and navigational errors
- Validate final Phase 1 MOPS



Ikhana Contact Information:

Mauricio Rivas

NASA AFRC, Ikhana Project Manager

661-276-3678

[mauricio.a.rivas@nasa.gov](mailto:mauricio.a.rivas@nasa.gov)

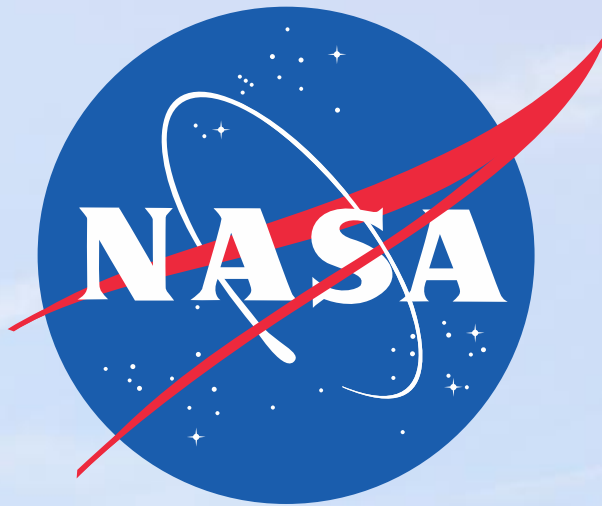

<http://www.nasa.gov/centers/armstrong/aircraft/Ikhana/index.html>