

# AZ-2000-IECW and StaMet Black Kapton Options for Solar Probe Plus MAG Sensor MLI Kevlar/Polyimide Shells

Michael K. Choi<sup>1</sup>

NASA Goddard Space Flight Center, Greenbelt, MD 20771

AZ-2000-IECW white paint and StaMet black Kapton have been evaluated for the Kevlar/polyimide shells that enclose the Solar Probe Plus Magnetometer (MAG) sensors and multilayer insulation. Flight qualification testing on AZ-2000-IECW painted Kevlar/polyimide laminate was completed at Goddard Space Flight Center. This paint potentially meets all the requirements. However, it has no flight heritage. StaMet is hotter in the sun, and is specular. The results of the MAG thermal balance test show StaMet meets the thermal requirement and heater power budget. The mission prefers to fly StaMet after evaluating the risks of AZ-2000-IECW flaking and glint from StaMet to the Star Trackers.

## Nomenclature

|                        |   |   |
|------------------------|---|---|
| <i>AC</i>              | = | alternating current   |
| <i>AFT</i>             | = | allowable flight temperature                                  |
| <i>ANSI/ESD</i>        | = | American National Standards Institute/electrostatic discharge |
| <i>AU</i>              | = | astronomical unit   |
| <i>CTE</i>             | = | coefficient of thermal expansion                              |
| <i>CDR</i>             | = | Critical Design Review  |
| <i>Comm</i>            | = | communication   |
| <i>DC</i>              | = | direct current  |
| $\eta$                 | = | heater controller efficiency                                  |
| $e^*$                  | = | effective emittance   |
| <i>EDTRD</i>           | = | Environmental Design and Test Requirements Document           |
| <i>EM</i>              | = | engineering model   |
| <i>EMECP</i>           | = | Electromagnetic Environment Control Plan                      |
| <i>ESA</i>             | = | European Space Agency   |
| <i>GSFC</i>            | = | Goddard Space Flight Center                                   |
| <i>HTR</i>             | = | heater  |
| <i>ISAS</i>            | = | Institute of Space and Astronautical Science                  |
| <i>ITO</i>             | = | indium tin oxide  |
| $R_s$                  | = | solar radii   |
| <i>MAG</i>             | = | Magnetometer  |
| <i>MEP</i>             | = | Main Electronics Package                                      |
| <i>MIL S</i>           | = | military specification  |
| <i>MLI</i>             | = | multilayer insulation   |
| <i>MMS</i>             | = | Magnetospheric Multiscale (MMS)                               |
| <i>SiO<sub>x</sub></i> | = | silicon oxide   |
| <i>SPP</i>             | = | Solar Probe Plus  |

## I. Introduction

**S**OLAR Probe Plus (SPP) is a NASA's Living with a Star mission. It is scheduled for launch from Cape Canaveral in July 2018. The primary scientific goal of the SPP mission is to understand how the Sun's corona is heated and how the solar wind is accelerated. A combination of in situ measurements and imaging will be used to

---

<sup>1</sup> Senior Aerospace Engineer, Heat Transfer, Mechanical Systems Division, Code 545, 8800 Greenbelt Road.

achieve this goal. The spacecraft is three-axis stabilized. It uses guidance and control sensors and attitude control thrusters to maintain the thermal protection system primary sunshield pointing toward the Sun. Fig. 1 shows the spacecraft. Fig. 2 shows the baseline SPP trajectory. It uses Venus flybys to reach a minimum perihelion of 8.5 solar radii ( $R_s$ ) or about  $6 \times 10^6$  km of the Sun's "surface" in approximately 6.5 years. The spacecraft will fly through a dust environment that has not been previously explored. It will encounter dust impacts at velocities of hundreds of km per second.<sup>1</sup> The Magnetometer (MAG) is a unit of the SPP FIELDS instrument, which will make direct measurements of electric and magnetic fields, radio emissions, and shock waves that course through the Sun's atmospheric plasma. It includes two sensors, inboard unit and outboard unit, which are mounted to a deployable boom (Fig. 1 and Fig. 3), and two circuit cards which are part of the FIELDS Main Electronics Package (MEP) mounted to a spacecraft equipment panel. The MAG is provided by NASA's Goddard Space Flight Center (GSFC). This paper is in conjunction with the MAG sensors. The two MAG sensors are separated by a distance of 0.8 m. The inboard sensor is approximately 1.9 m from the spacecraft aft end. The MAG boom is made of M55J composite that has a very low coefficient of thermal expansion (CTE), and is hollow. There is a connector plate about half way between the MAG sensors. Each MAG sensor has a pigtail harness that connects it to the connector plate. A spacecraft-provided harness connects the connector plate to the FIELDS MEP.

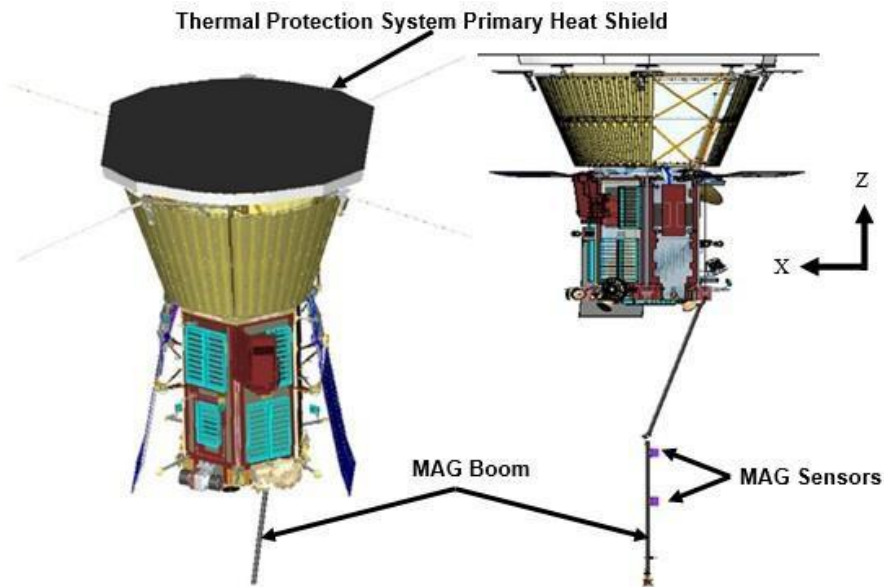

Figure 1. SPP with Solar Arrays Stowed (Left) and Deployed (Right) (credit: JHU APL and NASA).

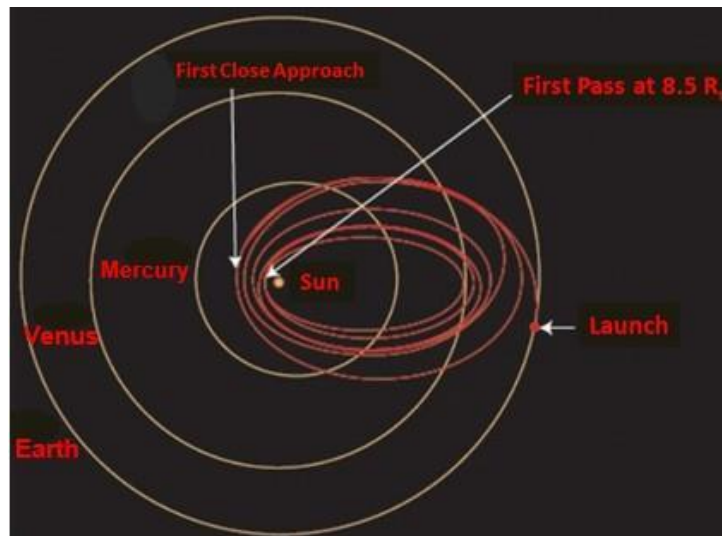
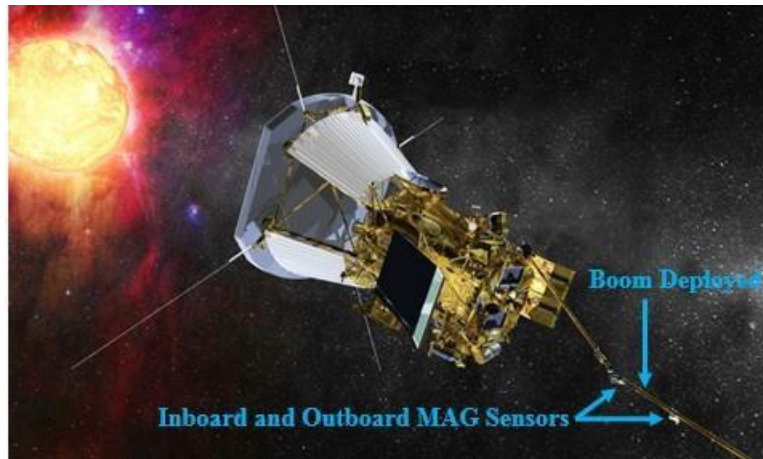

Figure 2. SPP Trajectory (credit: JHU APL and NASA).



**Figure 3. Location of MAG Sensors (credit: JHU APL and NASA).**

For a MAG sensor that measures weak interplanetary fields, the in-flight determination of zero levels is a crucial step of the overall calibration procedure<sup>2</sup>. Post-launch spacecraft MAG sensor zero levels can differ from their pre-launch values for many reasons. One of the most common issues is temperature changes of the sensor. A general review on space-based MAGs presented by Mario Acuna<sup>3</sup> also discussed this. To maintain the fluxgate MAG sensors within their optimum operating temperature range, it is necessary to provide heater power to the sensor assemblies<sup>4</sup>. Since it is extremely difficult to reduce the stray magnetic field associated with the operation of DC powered heater to acceptable levels for the MAG sensor, a magnetic amplifier operating at 50 kHz is used to obtain automatic, proportional control of AC power supplied to the heating elements<sup>4</sup>. The proportional heater controller temperature range of  $-15^{\circ}\text{C}$  to  $23^{\circ}\text{C}$ , which is also used for the Juno MAG sensor, is a reasonable choice for the SPP MAG sensors. A temperature range like  $-15^{\circ}\text{C}$  to  $23^{\circ}\text{C}$  allows the MAG sensor heater to function as temperatures vary in the operating range without turning on and off abruptly. The approximately  $40^{\circ}\text{C}$  range also allows for possible in-flight deviations from predicted temperatures.

The GSFC fluxgate MAG sensor on SPP is a high-heritage instrument. It has been or being flown on numerous NASA, ESA and ISAS missions, such as Voyager, AMPTE, MAGSAT, GIOTTO, DMSP, WIND, CLUSTER, MGS, GEOTAIL, Lunar Prospector, MESSENGER, STEREO, Juno and MAVEN. The MAG sensor is calibrated in the laboratory. Its minimum operating allowable flight temperature limit (AFT) is  $-20^{\circ}\text{C}$ . It is a heritage value from those missions. It is to optimize the MAG performance capabilities by ensuring in-flight calibration stays at nominal value<sup>5</sup>. The MESSENGER MAG sensor, for example, is maintained at no colder than  $-15^{\circ}\text{C}$  by heater during normal operations<sup>6</sup>. The Juno MAG sensor is also maintained at no colder than  $-15^{\circ}\text{C}$  by heater during normal operations. The maximum operating AFT limit is  $40^{\circ}\text{C}$ . It is also to optimize the MAG performance. Fig. 4 shows the SPP FIELDS MAG sensor engineering model (EM). Its enclosure consists of a base plate and a clamshell cover; both are made of carbon composite, which has low thermal conductivity, low CTE and high emittance. The sensor size is  $12.471\text{ cm} \times 7.62\text{ cm} \times 7.62\text{ cm}$ . Two bobbins, one horizontal and one vertical, are attached to the carbon composite. A heater, which consists of strips, is attached to the carbon composite underneath the bobbins. There is no contact between the heater and bobbins. The MAG sensor pigtail harness is  $0.3556\text{ m}$  (14 inch) long. Two heater controller thermistors, named HTR and MAG, are attached to a phenolic strip, which has heat radiation exchange with its surrounding. The proportional heater controllers are on the MEP MAG boards.

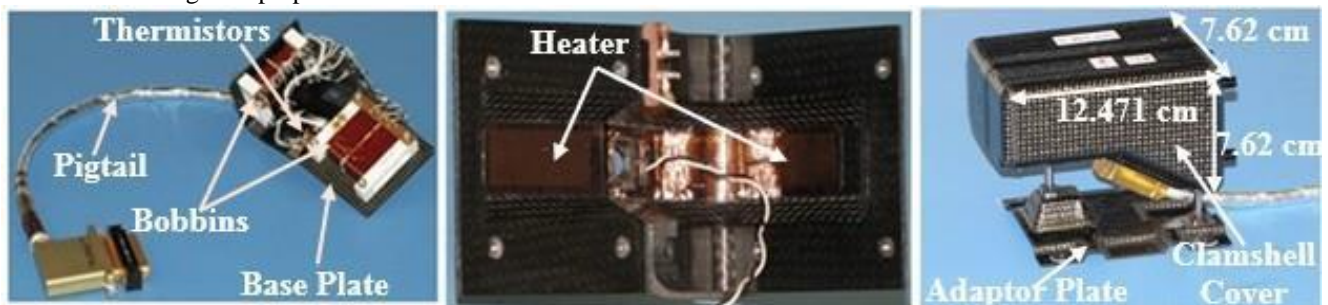

**Figure 4. SPP Fields MAG EM3 Sensor.**

## II. Requirements

There are several requirements for the SPP MAG sensors:

- Thermal: The operating AFT limits are  $-20^{\circ}\text{C}$  minimum and  $40^{\circ}\text{C}$  maximum. The non-operating AFT limits are  $-40^{\circ}\text{C}$  minimum and  $70^{\circ}\text{C}$  maximum. The boom interface temperature limits in the Environmental Design and Test Requirements (EDTRD) are  $-150^{\circ}\text{C}$  minimum and  $+100^{\circ}\text{C}$  maximum. Based on spacecraft thermal analysis and boom thermal balance test results, the  $-150^{\circ}\text{C}$  is too severe and can be relaxed to  $-130^{\circ}\text{C}$ .
- Surface resistivity:  $10^5$  ohm/square (Electromagnetic Environment Control Plan (EMECP)).
- Spacecraft bus Star Tracker glint requirement (mission requirement that is not in EDTRD and was initiated after the Critical Design Review (CDR)).
- Limited heater power available: The SPP heater power budget for the MAG sensors is limited. The allocation at the FIELDS instrument Critical Design Review (CDR) was 1.86 W orbital average at the MEP MAG Boards per sensor. The heater power delivered to the heaters is smaller due to the heater controller efficiency. The heater power is much smaller than the flight heritage value.

## III. Objective

The coating for the SPP MAG MLI exterior at the CDR was indium tin oxide/silicon oxide (ITO/SiO<sub>x</sub>), which has a low solar absorptance and is highly specular. The mission initiated the spacecraft bus Star Tracker glint requirement after the CDR. Therefore, ITO/SiO<sub>x</sub> became a glint issue. The objective of this paper is to present the coating options evaluated after the CDR, and add protection to the MLI against solar dust and micrometeoroid impacts.

## IV. SPP Mission Extreme Thermal Environment for MAG Sensors

The power dissipation of each MAG sensor is only 0.05 W or less. It is at least an order of magnitude smaller than the heat leak of the sensor. The thermal environment drives the temperatures of the MAG sensor. Since the same heater and heater controller set point are used for both the operating and non-operating (survival) modes, in the same cold case thermal environment the temperature difference between operating and non-operating is less than  $5^{\circ}\text{C}$ . The worst hot case and worst cold case extreme thermal environment of the SPP mission for the MAG sensors in the EDTRD is as follows.

### A. Worst Hot Non-operating Case

The Comm Slew (Downlink) at 0.7 AU is the worst hot case for the SPP MAG sensors. The solar irradiance is  $2790\text{ Wm}^{-2}$  (2.04 suns). The spacecraft slews  $45^{\circ}$  about the Y-axis for approximately 200 times for downlinks (Fig. 5). Each Downlink is up to 10 hours. The MAG is non-operating in this case. During each Downlink, the MAG sensors and boom are exposed to the sun. Due to solar exposure, the MAG sensor temperature will increase. When the spacecraft slews back to its nominal attitude, the MAG sensors and boom are in the umbra, and will cool down. The temperature cycling of the MAG sensors will repeat for approximately 200 times.

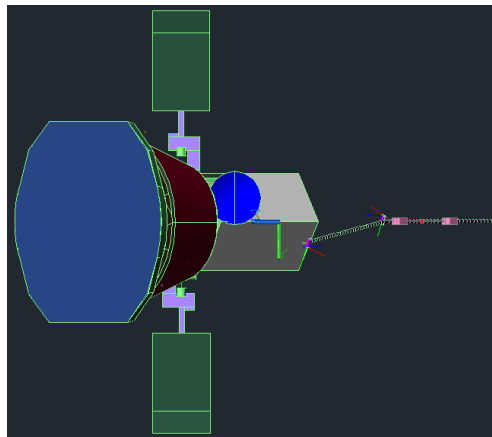

Figure 5. View from Sun during Comm Slew (Downlink) at 0.7 AU.

### B. Worst Cold Operating Case

The spacecraft is at its nominal attitude during instrument checkout, cruise, fanbeam and solid-state recorder playbacks at 0.82 AU (Fig. 6). Instruments are powered on. The MAG sensors are in the spacecraft's umbra.

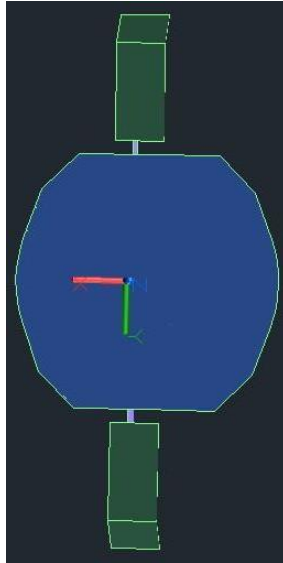

Figure 6. View from Sun during Instrument Operation at 0.82 AU.

### C. Worst Cold Non-operating Case

The Comm Slew (Downlink) at 0.76 to 0.28 AU is the worst cold non-operating case. The spacecraft does not slew for approximately 700 Downlinks (Fig. 7). Each Downlink is up to 10 hours. Instruments are powered off. The MAG sensors are in the spacecraft's umbra.

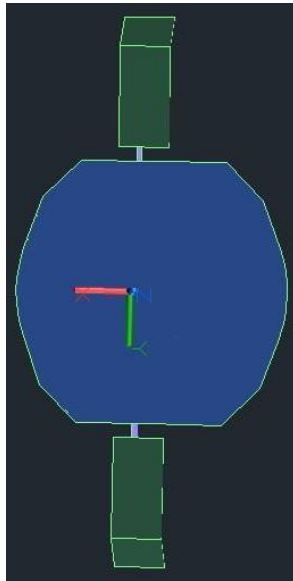

Figure 7. View from Sun during Downlink at 0.76 to 0.26 AU.

## V. SPP MAG Sensor Multilayer Insulation (MLI) Blankets and Shells

Due to low heater power budget, a key thermal design parameter for the SPP MAG sensors is the MLI effective emittance ( $e^*$ ). To minimize the thermal effect of 3K space in the worst cold case and solar flux at 0.7 AU (Downlink) in the worst hot case, 40 layers of MLI (a 15-layer MLI blanket on top of a 25-layer MLI blanket to allow flexibility) for the MAG sensor are used. Also 35 layers of MLI (a 15-layer MLI blanket on top of a 20-layer

MLI blanket to allow flexibility) for the MAG pigtail are used. Note that a 20-layer or 25-layer MLI blanket on MAG sensors has high flight heritage, despite the total number of layers of the two MLI blankets is larger than heritage. On the spacecraft side, the boom tube and boom Ti-6Al-4V brackets are also insulated with MLI blankets. The boom MLI is attached to the MAG sensor MLI in the vicinity of the adaptor plate.

In order to protect the MAG MLI and harness from damage caused by solar dusts and micrometeoroids, a separate Kevlar/polyimide laminate shell is used to enclose the MLI. The coating on the exterior of the shell is important to meet the requirements presented.

In flight, the MLI shell may not be flat. If sunlight is incident on a MAG sensor MLI shell at a 45° angle during downlink at 0.7 AU, some surfaces could have a solar incidence angle of less than 45°. Additionally, sunlight incident on the boom MLI will be reflected or scattered to the MAG MLI shells. If the boom MLI is warmer than the MAG MLI shells, it radiates heat to the latter.

At the CDR, the coating for the MAG MLI exterior was ITO/SiO<sub>x</sub>, which has a low absorptance (0.13 at beginning of life) and a medium hemispherical emittance (0.52). It has high flight heritage at GSFC. The spacecraft bus Star Tracker glint requirement was initiated by the mission after the CDR. Because ITO/SiO<sub>x</sub> is highly specular, it became a glint issue. After the CDR, the coating needed to be changed. The coatings, which were evaluated by the SPP FIELDS MAG project after the CDR, include black Kapton, AZ-2000-IECW and StaMet coated black Kapton, which is also known as StaMet black Kapton. The evaluation continued after the MAG flight hardware, without MLI, was delivered to the FIELDS instrument.

Black Kapton is specular, despite it is conductive and has a high absorptance and a high emittance. Assuming an absorptance of 0.93 and a hemispherical emittance of 0.79 in the hot case for black Kapton, its temperature prediction is 178°C (45° angle with sun) during downlink. The MLI layup needs a high temperature design without Dacron netting and with embossed Kapton inner layers. The effective emittance likely will increase.<sup>7</sup> The maximum MAG sensor temperature prediction is more than 110°C, which significantly exceeds its non-operating AFT limit. Diffuse black material is thermally no better than black Kapton, despite it is good for glint. Therefore, black Kapton is not an option.

AZ-2000-IECW white paint is conductive or dissipative per American National Standards Institute (ANSI)/ electrostatic discharge (ESD) S20.20-1999.<sup>8,9</sup> Its surface resistivity is 10<sup>4</sup> to 10<sup>7</sup> ohm/square.<sup>8,9</sup> It is non-specular.<sup>8</sup> Fig. 8 shows its bidirectional reflectance distribution function (BRDF) and angle resolved scatter (ARS) measured for the SPP MAG project. The latter is scattered power per steradian normalized by incident power. AZ-2000-IECW has a low absorptance (0.25±0.02) and a high emittance (0.88±0.02).<sup>7</sup> Assuming an absorptance of 0.45 and a hemispherical emittance of 0.85 in the hot case, its temperature prediction is modest (95°C at 45° angle with sun) when it is exposed to the sun at 0.7 AU for downlink. MLI layup with Dacron netting separators is acceptable. Fig. 9 shows the MLI layup. The maximum MAG sensor temperature prediction is 40°C. However, AZ-2000-IECW white paint has no flight heritage, especially on flexible materials.

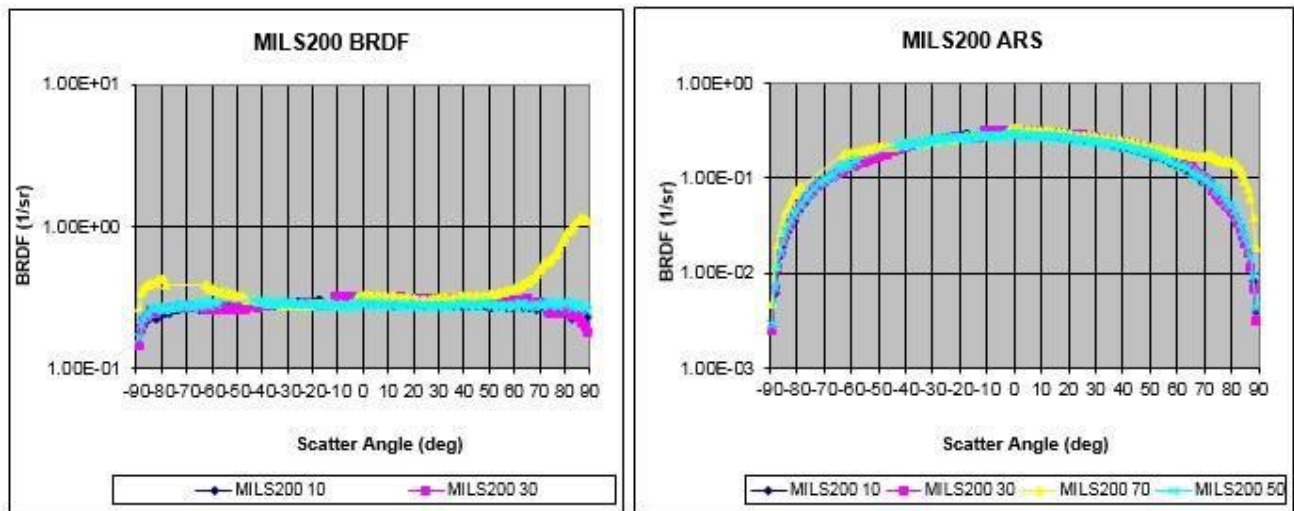

Figure 8. BRDF of AZ-2000-IECW White Paint Sample.

StaMet is a silicon aluminium alloy. It has the same optical and electrical properties as germanium, but has less susceptibility to corrosion. StaMet black Kapton is highly specular. The specularity of germanium black Kapton was

measured at GSFC for the Origins, Spectral Interpretation, Resource Identification, Security, Regolith Explorer (OSIRIS-REx) mission to be 0.69.<sup>10</sup> Therefore, StaMet black Kapton may have potential glint issues for the spacecraft Star Trackers. It has a medium absorptance and a high emittance. Assuming an absorptance of 0.56 and a hemispherical emittance of 0.75 in the hot case, its temperature prediction is high (132°C at 45° angle with sun) when it is exposed to the sun at 0.7 AU for downlink. The MLI layup needs to be high temperature design without Dacron netting and with embossed Kapton inner layers for MLI 1A (15-layer outer MLI). Fig. 10 shows the MLI layup. The effective emittance likely will increase.<sup>7</sup> Heat leak in the cold operating case at nominal attitude is expected to increase. Since heater power is limited, a verification of heater power required for this coating option was necessary. The maximum MAG sensor temperature prediction is nearly 50°C. The GSFC MAG MLI flight heritage transfer adhesive is 3M 97057. It has a 107°C maximum service temperature limit. In order to use StaMet black Kapton, a change to the 3M 9082 high temperature acrylic transfer adhesive is necessary. It has no GSFC MAG MLI flight heritage. A verification of good adhesion, especially at cryogenics temperatures, for this coating option was also necessary. The GSFC Materials Branch has verified by testing that 3M 9082 has low outgassing (1.11% total mass loss (TML) and 0% collected volatile condensable materials (CVCM)).

AZ-2000-IECW and StaMet black Kapton were evaluated in parallel after the CDR to allow the SPP mission to make the final decision on which to fly.

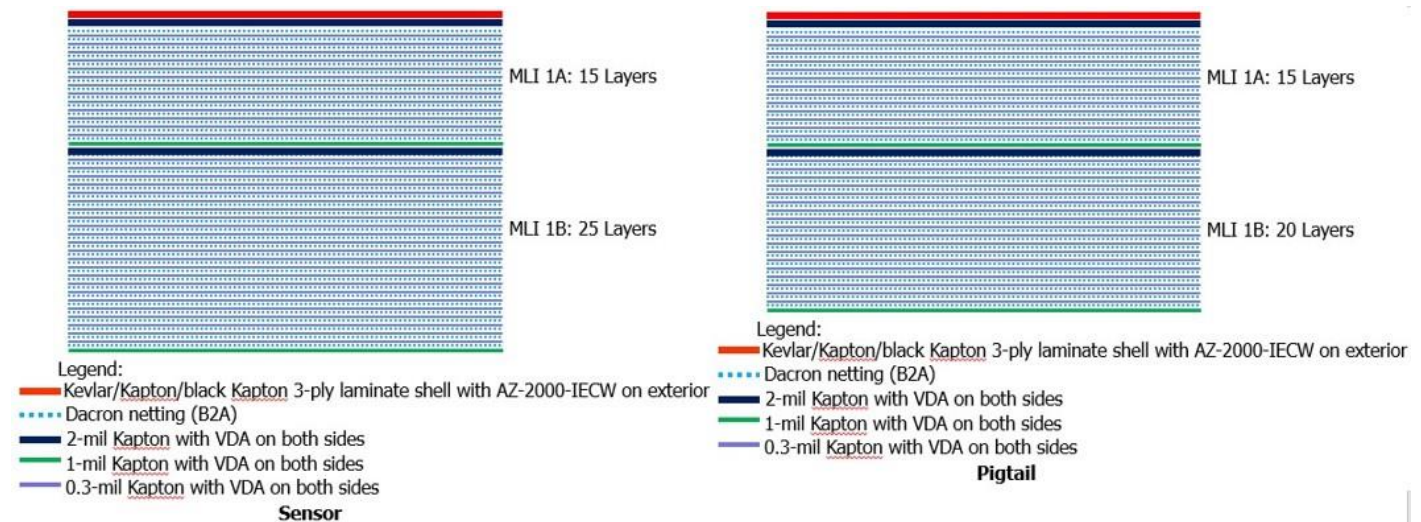

Figure 9. MLI Layup for AZ-2000-IECW Painted Shell.

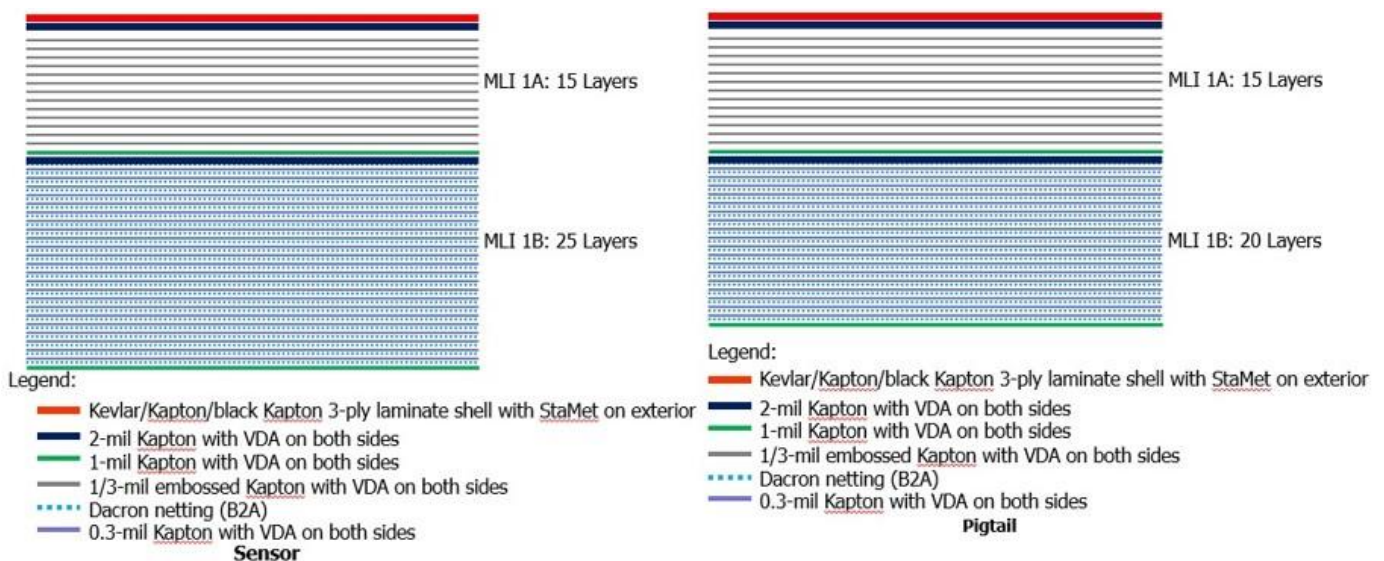

Figure 10. MLI Layup for StaMet Black Kapton Coating on Shell.

## VI. Flight Qualification Testing on AZ-2000-IECW Painted Black Kapton/Kevlar/Kapton Laminate

Three things were necessary to achieve good adhesion of AZ-2000-IECW to the black Kapton/Kevlar/Kapton laminate. First, the MLP-300-AZ epoxy primer was applied. Second, the primer received oxygen plasma treatment. Third, the paint thickness was reduced from 0.0102 cm (4 mil) in the specifications to 0.00635 cm (2.5 mil). The reduction in paint thickness had a negligible impact on the optical properties.

Flight qualification testing on AZ-2000-IECW coated black Kapton/Kevlar/Kapton laminate was completed at the GSFC Thermal Coatings Laboratory. It included the tests below.

- -190°C to +125°C thermal shocks (5 cycles).
- Tape lift (after thermal shocks).
- Thermal vacuum (TVAC) cycling, -150°C to +150°C.
- Tape lift after TVAC cycling.
- Vacuum resistivity after TVAC cycling.
- Optical properties – absorptance and emittance.
- Surface resistivity in vacuum.
- Bidirectional reflectance distribution function (BRDF).
- Solar wind (2x lifetime).
- Near ultraviolet (NUV) (2000 equivalent sun hours minimum).
- Outgassing (ASTM-E595).
- Acoustics fallout (or simulation).
- Tape lift after acoustics fallout.
- Wear (bending, twisting, sliding abrasion).
- Tape lift after wear.
- Vacuum resistivity after wear.
- Vacuum resistivity after TVAC cycling and wear.
- Particulate count (handling and installation).

Fig. 11 shows a test sample of AZ-2000-IECW painted black Kapton/Kevlar/Kapton laminate after 75 thermal vacuum cycles from -150°C to +150°C followed by tape lift. The white paint had no flaking even after bending and twisting. Fig. 12 shows an AZ-2000-IECW painted black Kapton/Kevlar/Kapton laminate shell that fitted the MAG sensor.



Figure 11. AZ-2000-IECW Painted Black Kapton/Kevlar/Kapton Sample After 75 TVAC Cycles and Tape Lift.



Figure 12. AZ-2000-IECW Painted Black Kapton/Kevlar/Kapton Laminate Shell.



Flight qualification test results showed that AZW-2000-IECW white paint is a viable option for the SPP MAG sensor flight MLI shell. A second option was deemed necessary due to a SPP mission level contamination concern on flaking of the AZ-2000-IECW white paint. StaMet black Kapton is an alternate, despite its potential glint issue. A thermal balance test on the MAG EM3 sensor, which had StaMet black Kapton as the coating for MLI shells, was completed to help the mission making the final decision on which coating to fly. The purpose of the thermal balance test was to verify that the StaMet black Kapton option meets the heater power budget and thermal requirement. A similar thermal balance test was previously performed on the AZW-2000-IECW white paint option. It verified that the white paint option meets the heater power budget and thermal requirement. Additionally, the thermal balance test for the StaMet black Kapton option was to verify that the adhesion of the 3M 9082 transfer adhesive is good after its exposure to temperature extremes ( $<-180^{\circ}\text{C}$  to  $+160^{\circ}\text{C}$ ) expected in flight.

## VII. SPP MAG Sensor Thermal Balance Test

A thermal balance test was performed on the SPP MAG EM3 sensor, which is flight-like, from November 7-19, 2016 in a vacuum chamber at the GSFC Solar Wind Facility. Fig. 13 shows the test set up in the vacuum chamber. It consisted of four cold test cases (#1-#4) using DC heater mode, four cold test cases (#5 and #5A-#5C) using flight-like AC heater mode, two hot test cases (#6 and #6A) using no heater power, and a cold test case (#7) with same mounting interface temperature and sensor temperature. Cold test cases #5A-#5C were to evaluate the effect of the spacecraft bus voltage. Hot test case #6A was to evaluate the effect of more margin on StaMet black Kapton temperature in sunlight during downlink at 0.7 AU. Cold test case #7 was to separate the radiative heat leak through MLI blankets from the conductive heat leak through the mounting interfaces. An aluminum L-bracket was added for test cases #6 and #6A after a vacuum break (Fig. 14). Kapton heaters and thermocouples were attached to it to achieve the worst hot case equivalent sink temperature plus a  $10^{\circ}\text{C}$  or more uncertainty margin for StaMet black Kapton during the Comm Slew (Downlink) at 0.7 AU. The L-bracket surfaces that had views to the chamber shroud were covered by MLI blankets. The MAG sensor was non-operating in the thermal balance test.



Figure 13. Test Set Up in Chamber.

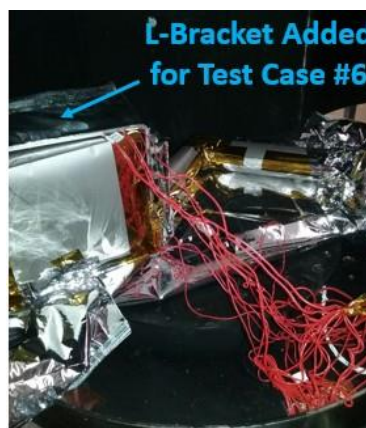

Figure 14. L-Bracket Added for Test Case #6.

Table 1 is a summary of the thermal balance test results for the StaMet black Kapton coating option. Furthermore, Table 2 presents the electrical power to the MEP MAG EM3 board calculated based on the voltage and current recorded during test cases #5 and #5A-#5C. Note that the heater power delivered to the heater is the power to the MEP MAG EM3 board multiplied by the efficiency ( $\eta$ ) of the heater controller. By extrapolating the results of test cases #5A-#5C, the MAG sensor thermistor temperatures are estimated to be  $-35^{\circ}\text{C}$  and  $-28^{\circ}\text{C}$  at bus voltages of 24 V and 26 V, respectively. The mounting interface temperature was  $-130^{\circ}\text{C}$ , which is the minimum expected in flight. The input power to the heater controller on the MEP MAG board is estimated to be 2.06 W and 2.24 W at bus voltages of 24 V and 26 V, respectively. The heater power delivered to the heater is estimated to be 1.58 W and 1.72 W at bus voltages of 24 V and 26 V, respectively. At voltages below 26 V, the MAG will be non-operating. Its temperature is above the minimum non-operating AFT limit.

**Table 1. Thermal Balance Test Results for StaMet Option.**

| Test Case # | Mounting Plate Temperature ( $^{\circ}\text{C}$ ) | Chamber Shroud Temperature ( $^{\circ}\text{C}$ ) | L-Bracket Temperature ( $^{\circ}\text{C}$ ) | Heater Power (W)              | Voltage (V) | Current (A) | Thermistor Temperature ( $^{\circ}\text{C}$ ) |       |
|-------------|---|---|--|-------------------------------|-------------|-------------|---|-------|
|             |   |   |  |                               |             |             | HTR   | MAG   |
| 1           | -153  | -185  | N/A  | 1.8                           | 13.12       | 0.137       | -30.3   | -31.5 |
| 2           | -153  | -185  | N/A  | 1.6                           | 12.40       | 0.129       | -41.3   | -42.4 |
| 3           | -136  | -185  | N/A  | 1.6                           | 12.40       | 0.129       | -28.4   | -29.4 |
| 4           | -136  | -185  | N/A  | 1.8                           | 13.12       | 0.137       | -18.5   | -19.5 |
| 5           | -136  | -185  | N/A  | $30 \times 0.083 \times \eta$ | 30*         | 0.083*      | N/A   | -14.2 |
| 5A          | -132  | -185  | N/A  | $30 \times 0.086 \times \eta$ | 30*         | 0.086*      | N/A   | -17.8 |
| 5B          | -132  | -185  | N/A  | $28 \times 0.086 \times \eta$ | 28*         | 0.086*      | N/A   | -22.6 |
| 5C          | -132  | -185  | N/A  | $32 \times 0.087 \times \eta$ | 32*         | 0.087*      | N/A   | -14.2 |
| 6           | 96  | -185  | 152  | 0                             | 0           | 0           | N/A   | 46.6  |
| 6A          | 96  | -185  | 165  | 0                             | 0           | 0           | N/A   | 47.6  |
| 7           | -13.7   | -185  | N/A  | 0.57                          | 7.35        | 0.77        | -13.6   | -13.4 |

\*To MEP MAG board.

**Table 2. Voltage, Current and Power to MEP MAG EM3 Board.**

| Test Case # | Voltage to MEP MAG EM3 Board (V) | Current (A) | Power Input to MEP Board (W) | Heater Power Delivered to Heater (W) |
|-------------|----------------------------------|-------------|------------------------------|--------------------------------------|
| 5           | 30                               | 0.083       | 2.490                        | $2.490 \times \eta$                  |
| 5A          | 30                               | 0.086       | 2.580                        | $2.580 \times \eta$                  |
| 5B          | 28                               | 0.086       | 2.408                        | $2.408 \times \eta$                  |
| 5C          | 32                               | 0.087       | 2.784                        | $2.784 \times \eta$                  |

### VIII. Analysis of SPP MAG Sensor Thermal Balance Test Results

Below is a summary of analysis of the SPP MAG sensor thermal balance test results.

- In test cases #1-#5, with the chamber shroud and mounting interface temperatures fixed, a 0.2 W increase in heater power increased the sensor temperature by  $10^{\circ}\text{C}$  to  $11^{\circ}\text{C}$ .
- In test cases #1-#5, with the chamber shroud temperature and heater power fixed, a  $20^{\circ}\text{C}$  increase in mounting interface temperature increased the sensor temperature by  $12^{\circ}\text{C}$  to  $13^{\circ}\text{C}$ .
- In test cases #1-#5, with the chamber shroud temperature fixed, a  $20^{\circ}\text{C}$  increase in the mounting interface temperature and a 0.2 W decrease in heater power nearly maintained the same sensor thermistor temperature.
- At 30 V, which is the nominal spacecraft bus voltage, and a  $-130^{\circ}\text{C}$  mounting interface temperature, a 2.49 W input power to the MEP MAG board led to a  $-14.2^{\circ}\text{C}$  thermistor temperature.
- If the mounting interface temperature in flight is  $-130^{\circ}\text{C}$  or warmer, at voltages of 30 V or larger, the MAG

sensor temperature is expected to be within the flight heritage temperature range of  $-15^{\circ}\text{C}$  to  $23^{\circ}\text{C}$ .

- Test cases #5 and #5A-#5C revealed that electrical power input to the MEP MAG board increased by about 0.085 W per volt and the sensor thermistor temperature increased by about  $2^{\circ}\text{C}$  per volt.
- In test case #5, the heater power delivered to the heater was estimated to be 1.92 W, and the MEP MAG board heater controller efficiency ( $\eta$ ) is estimated to be 76.7%.
- In test case #5, with nearly the same sensor thermistor temperature as test case #7, the radiative heat leak from the sensor, including the pigtail, to the chamber shroud is about 0.62 W (i.e., 0.57 W + 0.05 W radiative heat loss from the sensor baseplate to the  $-136^{\circ}\text{C}$  mounting plate).
- In test cases #6 and #6A, the sensor temperature had adequate margin since the maximum non-operating AFT limit is  $70^{\circ}\text{C}$ .
- In test case #7, the heat leak by conduction from the sensor, including the pigtail, to the mounting plate was negligible.
- In test case #7, the heat leak by radiation from the sensor to the mounting plate was negligible.
- In test case #7, the heat leak by radiation from the sensor, including the pigtail, to the chamber shroud was 0.57 W.
- Test cases #5 and #7 revealed the heat leak by radiation from the sensor through MLI in case #5 is about 0.62 W and the heat leak by conduction from the sensor, including the pigtail, to the mounting plate was about 1.3 W.
- The conductance through the mounting interfaces is about  $0.008\text{ W}/^{\circ}\text{C}$ .
- A minimum budget of 2.5 W power input for the MEP MAG board per sensor is required.
- The 3M 9082 high temperature acrylic transfer adhesive had good adhesion and is not an issue for flight use.

Based on the above thermal balance test results, the MLI design option with StaMet black Kapton as the coating for the Kevlar/polyimide shells meets the thermal requirement and has adequate margins. It barely meets the heater power budget. In comparison to the thermal balance test results for the AZ-2000-IECW option, the heater power for the worst cold case is about 0.1 W higher. This attributes to a larger effective emittance ( $e^*$ ) of the 15-layer outer MLI with a layup for high temperature design. It is expected.

### IX. Selection of Coating for Kevlar/Polyimide Shells

The SPP mission prefers StaMet black Kapton for flight use, despite it is specular. The mission does not prefer the AZ-2000-IECW white paint option because the risk of contamination due to flaking is larger than the stray light risk of StaMet black Kapton. Fig. 15 shows the two flight and one spare flight Kevlar/polyimide shells with StaMet black Kapton for the sensors. Fig. 16 shows the two flight and one spare flight Kevlar/polyimide shells with StaMet black Kapton for the pigtails. Installation of the MLI and Kevlar/polyimide shells to the MAG flight units, which is part of the boom integration work, is scheduled for late April 2017.

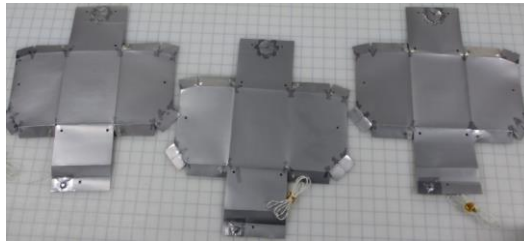

Figure 15. Two Flight and One Spare Flight Kevlar/Polyimide Shells with Stamet Black Kapton for Sensors.



Figure 16. Two Flight and One Spare Flight Kevlar/Polyimide Shells with StaMet Black Kapton for Pigtails.

## X. Conclusion

Low heater power budget (about half of the heritage value), extreme thermal environment, extreme boom interface temperatures,  $10^5$  ohm/square surface resistivity requirement and spacecraft bus Star Tracker glint requirement drove changes in thermal design, including MLI blankets, to the high-heritage GSFC fluxgate MAG sensor to be flown on SPP. The Star Tracker glint requirement was initiated by the mission after the CDR. Therefore, the coating (ITO/SiO<sub>x</sub>) for the Kevlar/polyimide laminate shells presented at the CDR needed to be changed. The overall MLI blanket design changes are to minimize the radiative heat leak to the space environment, meet the surface resistivity and Star Tracker glint requirements, and to provide protection from impacts of solar dust and micrometeoroid. Two coatings, AZ-2000-IECW white paint and StaMet black Kapton, have been evaluated for the Kevlar/polyimide laminate shells after the CDR. Flight qualification testing on AZ-2000-IECW painted Kevlar/polyimide laminate was completed at GSFC in 2016. This white paint potentially meets all the requirements. However, it has no flight heritage, especially on a flexible material. In order to achieve good adhesion of AZ-2000-IECW to the Kevlar/polyimide laminate, the MLP-300-AZ epoxy primer is important. Additionally, oxygen plasma treatment for the primer is important. Reducing the paint thickness from 0.0102 cm (4 mil) in the specifications to 0.00635 cm (2.5 mil) also enhances adhesion. StaMet black Kapton is significantly hotter in the sun. The results of the MAG EM3 sensor thermal balance test showed that a) it meets the thermal requirement with adequate margins, and b) it barely meets the heater power budget, despite it requires about 0.1 W more heater power than the AZ-2000-IECW white paint option in the worst cold case. The only concern is its specularly. Therefore, it does not have zero glint issue for the Star Trackers. Reflection of sunlight from the specular part of the deployable instrument at the tip of the vertical booms to the star trackers on the Magnetospheric Multiscale (MMS) spacecraft caused glint anomaly in flight. It is a lesson learned.

The SPP mission evaluated the risk of contamination due to flaking of the AZ-2000-IECW white paint and the risk of glint due to reflection of sunlight from the StaMet black Kapton to the Star Trackers. It prefers the StaMet black Kapton option for the flight MLI on the MAG sensors. Although AZ-2000-IECW white paint is not going to be flown on the SPP MAG Kevlar/polyimide laminate shell, it paves the way for its use in future NASA missions. The technique of applying AZ-2000-IECW white paint to flexible materials developed in the flight qualification testing program is also applicable to other conductive silicate white paints.

## Acknowledgments

The author would like to thank Kenneth O'Connor and Mark Hasegawa of the GSFC Thermal Coatings Laboratory for their support on flight qualification testing of AZ-2000-IECW on Kevlar/polyimide laminates.

## References

- <sup>1</sup> Mehoke, D.S., "A review of the Solar Probe Plus dust protection approach", Aerospace Conference, 2012 IEEE.
- <sup>2</sup> Leinweber, H. K., et al., "An Advanced Approach to Finding Magnetometer Zero Levels in the Interplanetary Magnetic Field", *Meas. Sci. Technol.* 19 055104, 2008.
- <sup>3</sup> Acuna, M., et al., "Space-Based Magnetometers", *Rev. Sci. Instrum.* 73, 3717 (2002).
- <sup>4</sup> Lepping, R. P., et al., "The Wind Magnetic Field Investigation", *Space Science Reviews*, Volume 71, Issue 1-4, pp. 207-229, 1995.
- <sup>5</sup> Acuna, M., et al., "The STEREO/IMPACT Magnetic Field Experiment", *Space Sci Rev* (2008) 136: 203–226.
- <sup>6</sup> Anderson, B., et al., "The MESSENGER Magnetic Fields Experiment", *Space Sci. Rev.*, 131: 417-540).
- <sup>7</sup> Lin, E. I. et al., "Test-Derived Effective Emittance for Cassini MLI Blankets and Heat Loss Characteristics in the Vicinity of Seams," AIAA Paper 95-2015, June 1995.
- <sup>8</sup> AZ-2000-IECW White Thermal Control, Electrically Conductive Paint/Coating data sheet, AZ Technology, Inc., Huntsville, AL.
- <sup>9</sup> Ferguson, D. C. and Rhee, M. S., "Controlling Charging and Arcing on a Solar Powered Auroral Orbiting Spacecraft," Photovoltaic Specialists Conference, 2008. PVSC '08. 33rd IEEE.
- <sup>10</sup> Freese, S., "Thermal Property Measurement and Diffuse Reflectance Characterization Germanium Black Kapton for the OSIRIS-REx Mission", TCR# 0644-032114, NASA GSFC, March 21, 2014.