



Seeing Shock Waves: Background Oriented Schlieren for Flight Test

Nils Larson (AF)

Dan Banks

NASA Armstrong Flight Research Center

Edwards AFB, CA USA

July 14, 2017

SETP 49th European Symposium





Agenda

- Background
- AirBOS
- BOSCO
- Flight Test Operations
- Summary
- Lessons Learned



Background

- What is schlieren?
 - Schlieren comes from the German word for “Streak”. It is a method of visualizing density gradients, typically in the form of shock waves.
- Classical schlieren uses a setup of very high quality mirrors and lights. A partial cutoff at the focus (knife-edge) creates the effect.
- Background Oriented Schlieren (BOS) uses the distortion in a random background pattern to deduce the density gradients.
 - Image processing used to resolve shock waves or other density gradients, like vortices.



Classical Schlieren

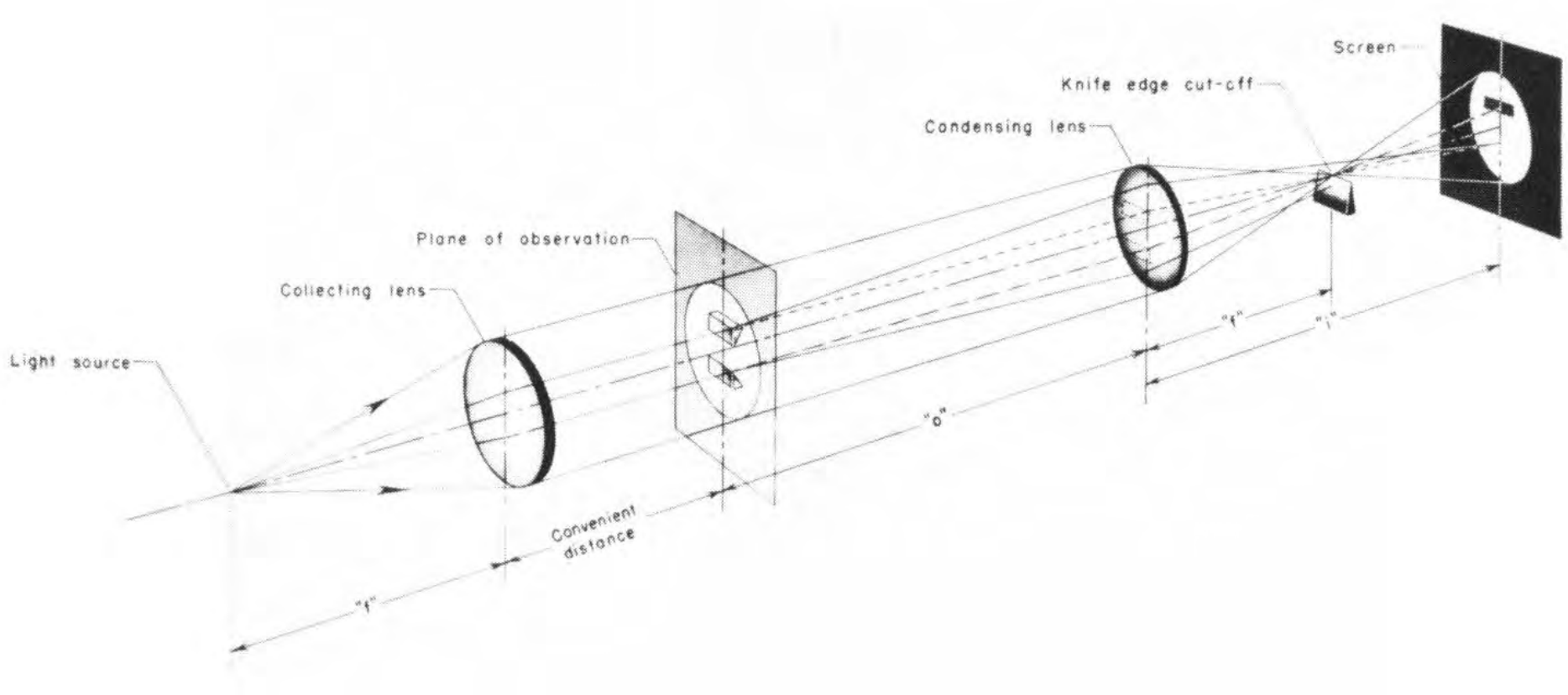

- Requires very precise (expensive) optics and lights
 - Method derived from technique to test optics
- Would be prohibitively difficult to implement in flight



Background Oriented Schlieren

Wind Tunnel Application

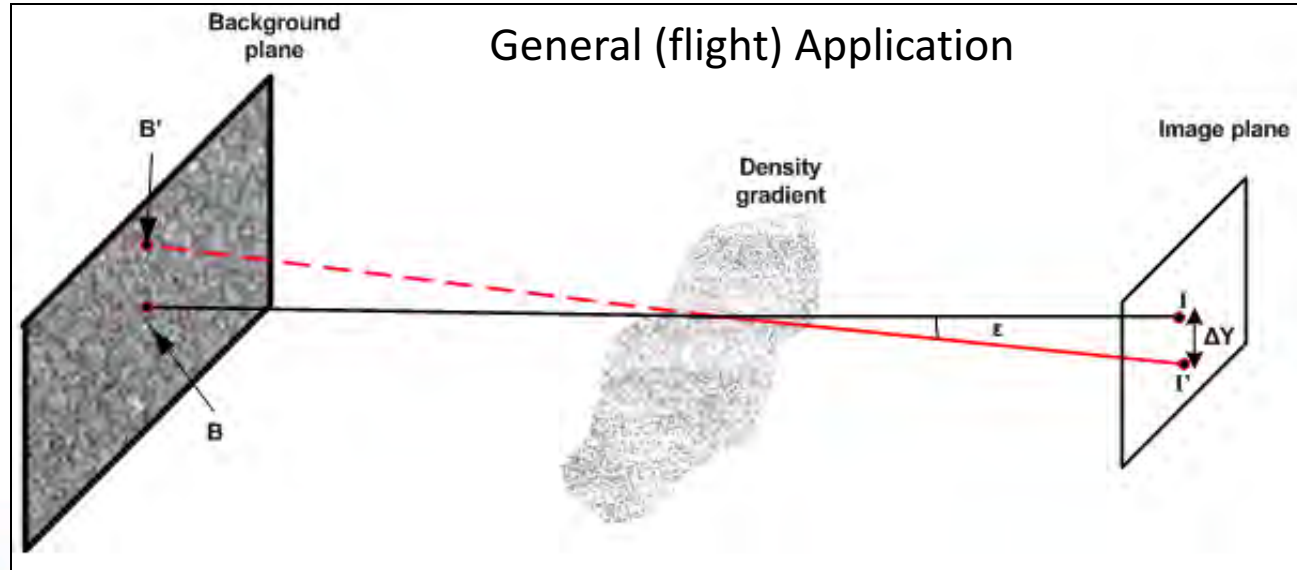
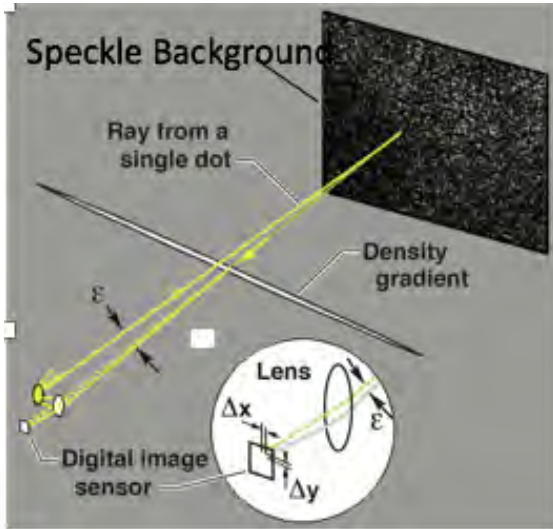

Deduces shock waves (density gradient) by the apparent shifting of objects in the background caused by refraction of the light rays

Gladstone-Dale Relationship: $(n-1)/d = \text{Constant}$
n is index of refraction
d is density

Image processing is used to resolve the shock waves (density gradient)

- Short version is the image with the shock waves is compared to a reference image (same background without the shock waves)
- 2 methods: cross correlation and optical flow



Ground-to-Air Solar Edge Schlieren

T-38, Circa 1993, Leonard Weinstein

Digital Equivalent using MetroLaser hardware, processed with NASA Armstrong algorithms, 2013.

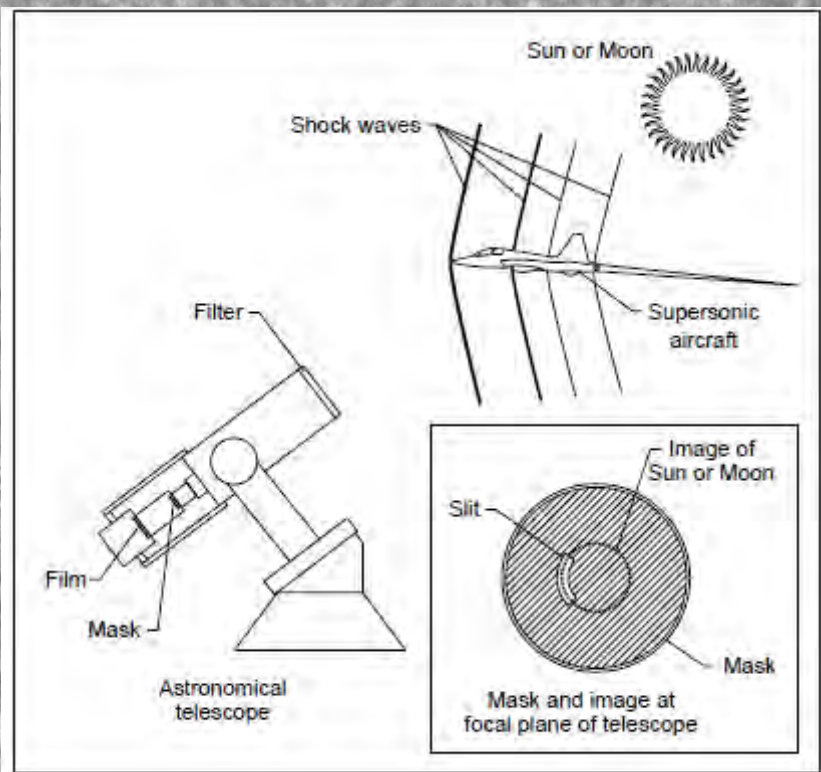
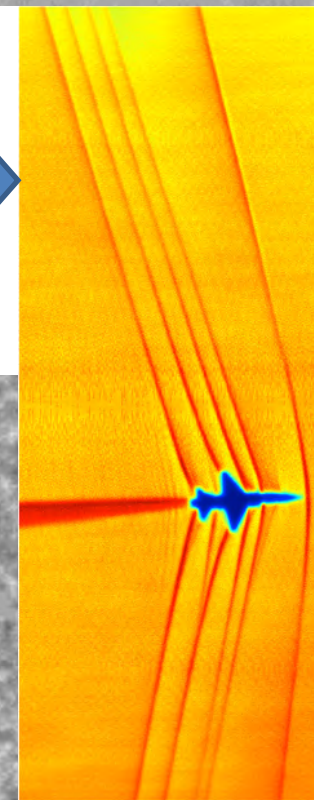



Types of In-Flight Background Oriented Schlieren Flow Visualization

- AirBOS, Air-to-air Background Oriented Schlieren
 - Downward looking at desert vegetation or ocean speckles
 - Wide field of view, very detailed
 - Limited by separation
 - Profile view unless aggressive maneuvers to get side view
 - > OK for fighters not for others

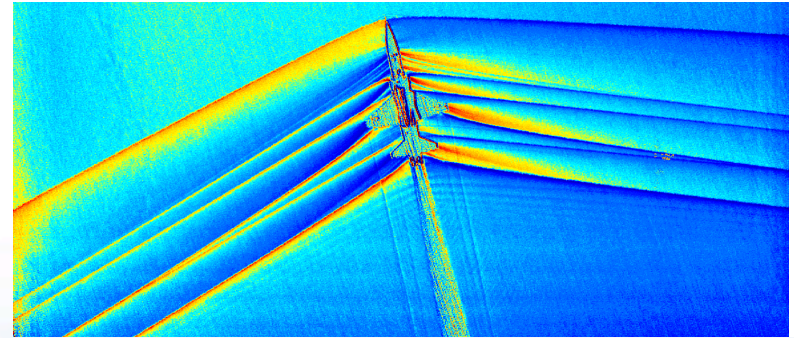

- BOSCO, Background Oriented Schlieren using Celestial Objects
 - Ground based (upward) or air-to-air (side view) looking at Sun/Moon
 - Currently ground-to-air, but working toward air-to-air capability
 - 0.5 deg field of view

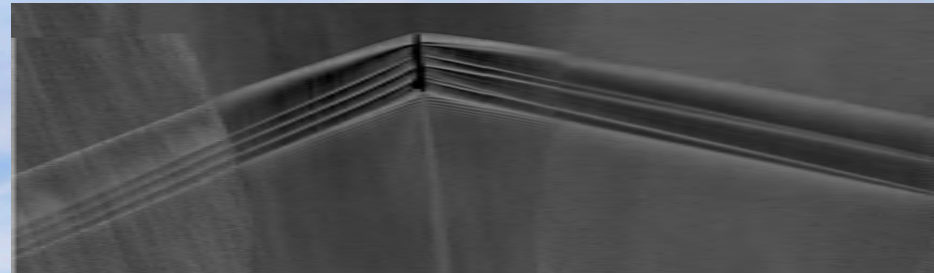



Motivation

- NASA Commercial Supersonic Technology
 - Desire for a schlieren system for full scale aircraft in flight to visualize shockwaves generated by supersonic aircraft
 - Validate/refine shock modeling for low boom airframe design



Photo Credit: Lockheed Martin

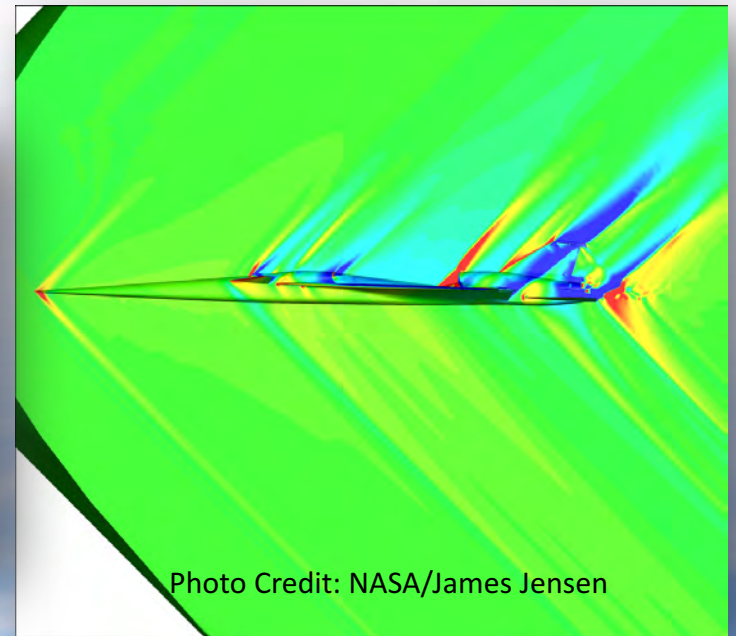
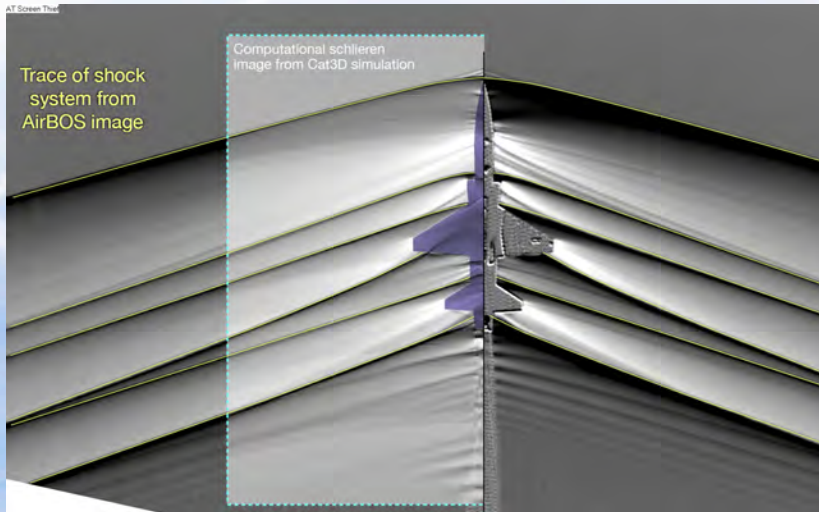
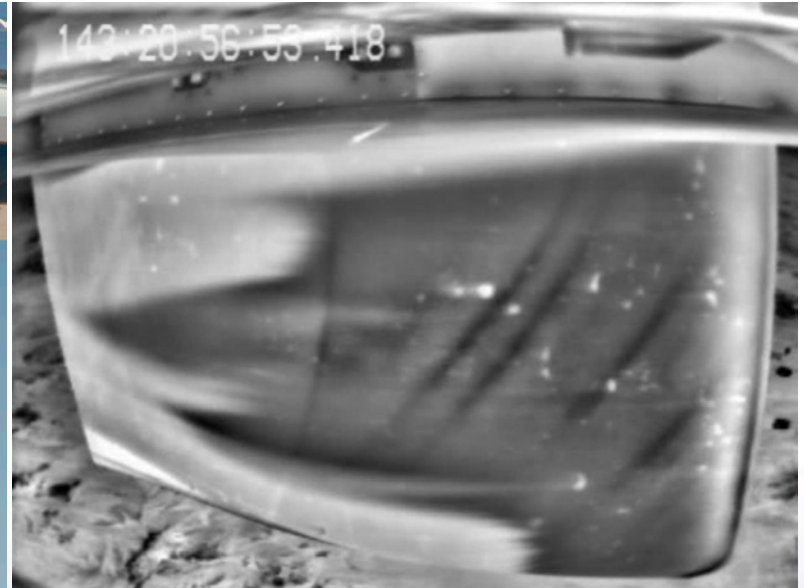

Photo Credit: NASA/James Jensen



More Motivation



Many more shocks actually seen in flight than predicted (CFD) or seen in wind tunnel tests.



AirBOS Concept

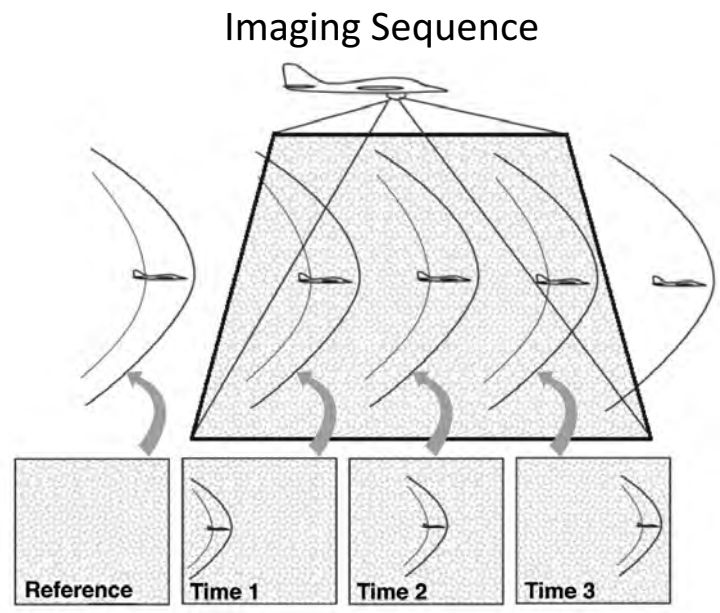
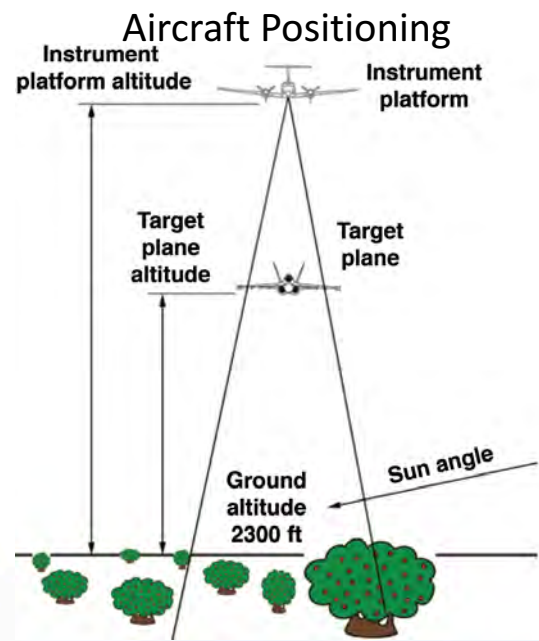

Desert bush
Close up



Desert bush(es)
From altitude





Sensor Platform

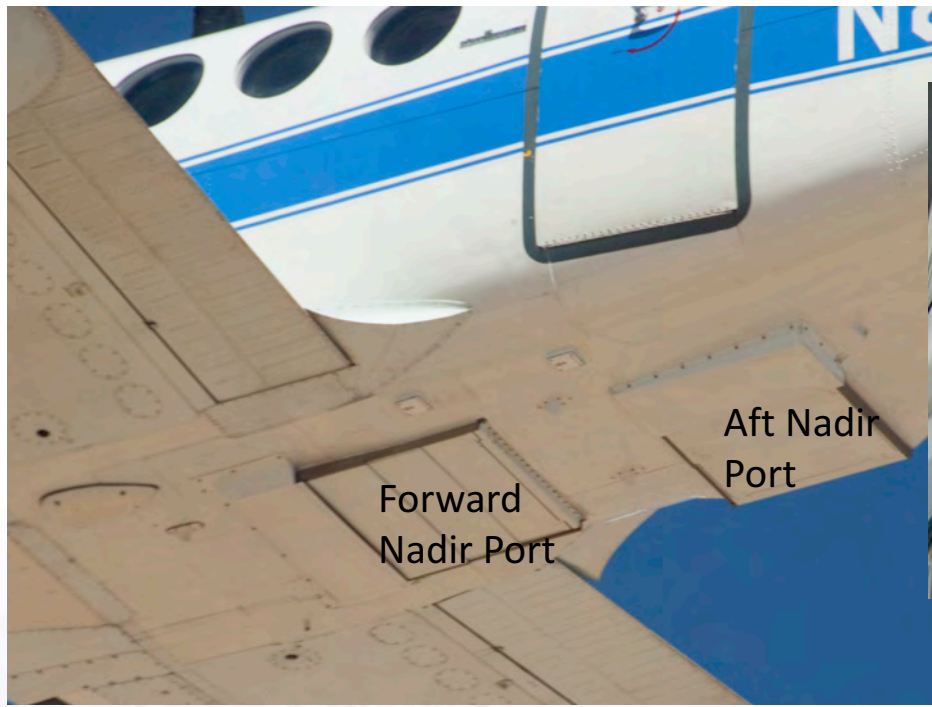

Cabin setup and FTE's

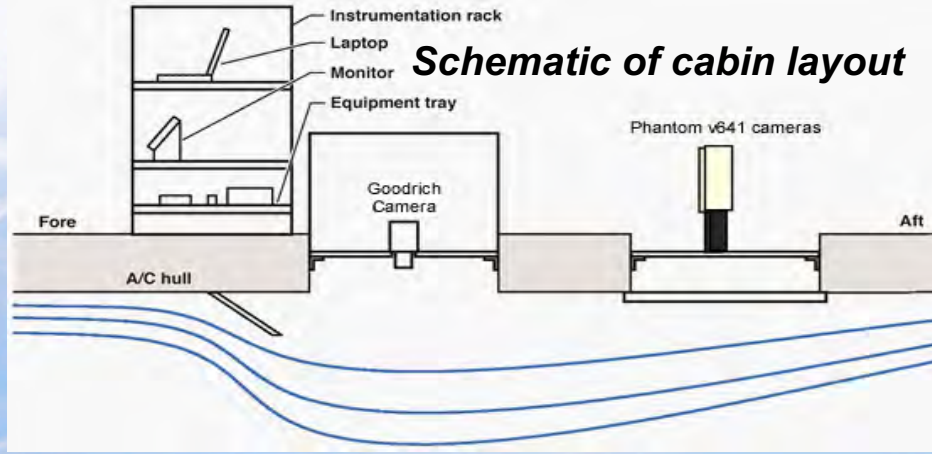



T-38 RAW Image Sequence

M=1.05, 2,000' separation

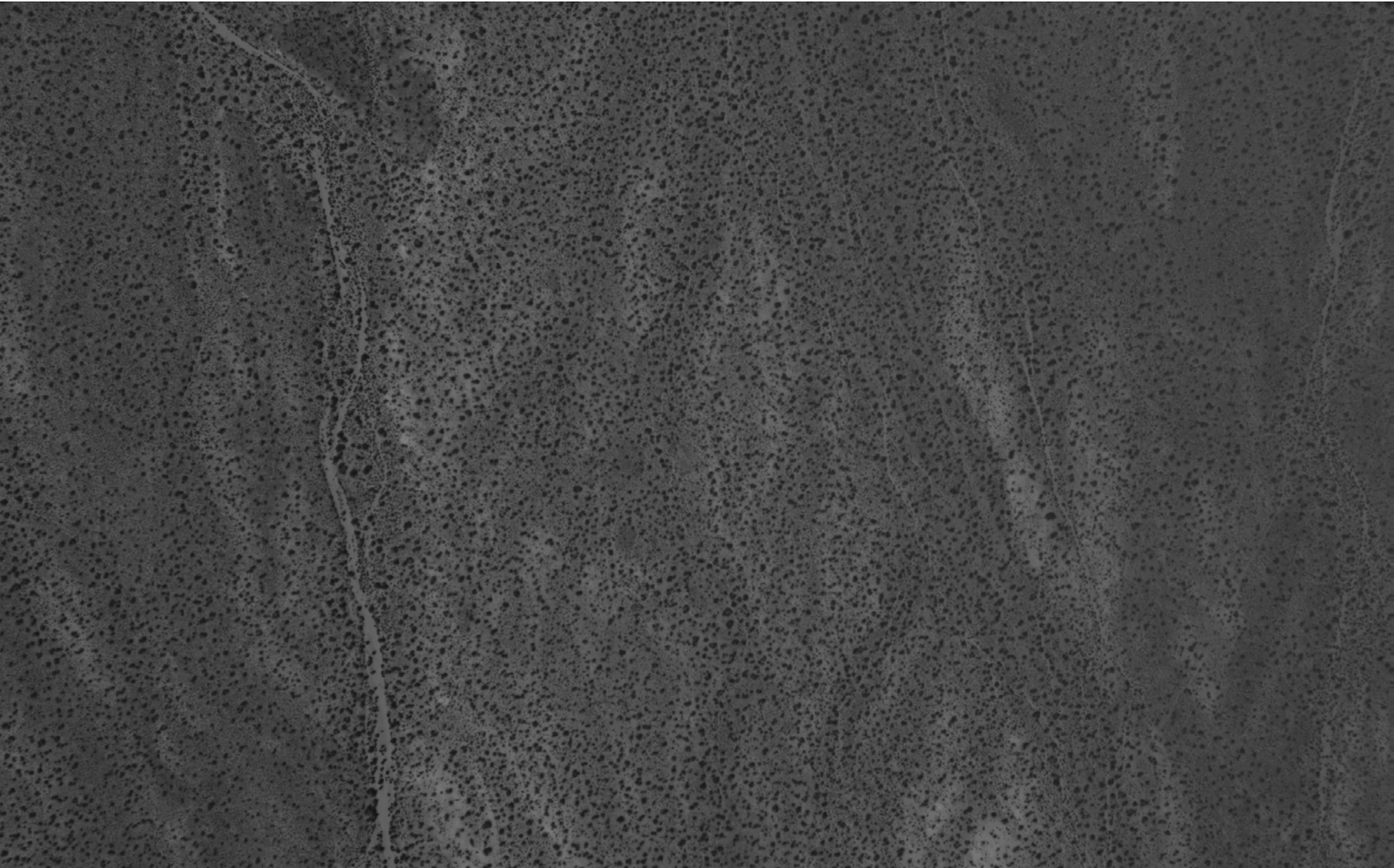



T-38 [AirBOS: Cross-Correlation, dy]

$M=1.05$; 2,000' separation; $\phi=45^\circ$

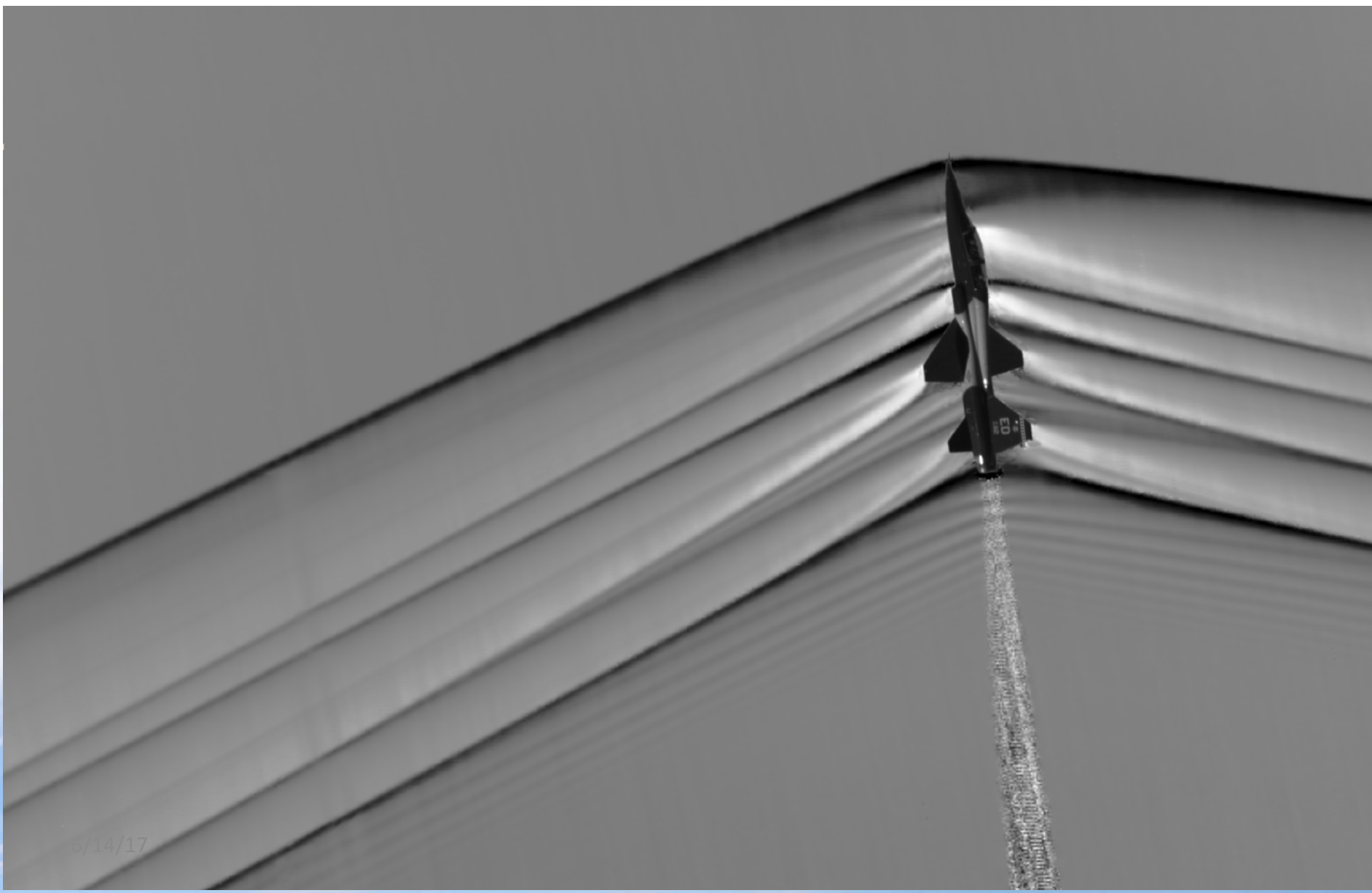



T-38 [AirBOS: Cross-Correlation, dx]

M=1.05; 2,000' separation; $\phi=45^\circ$

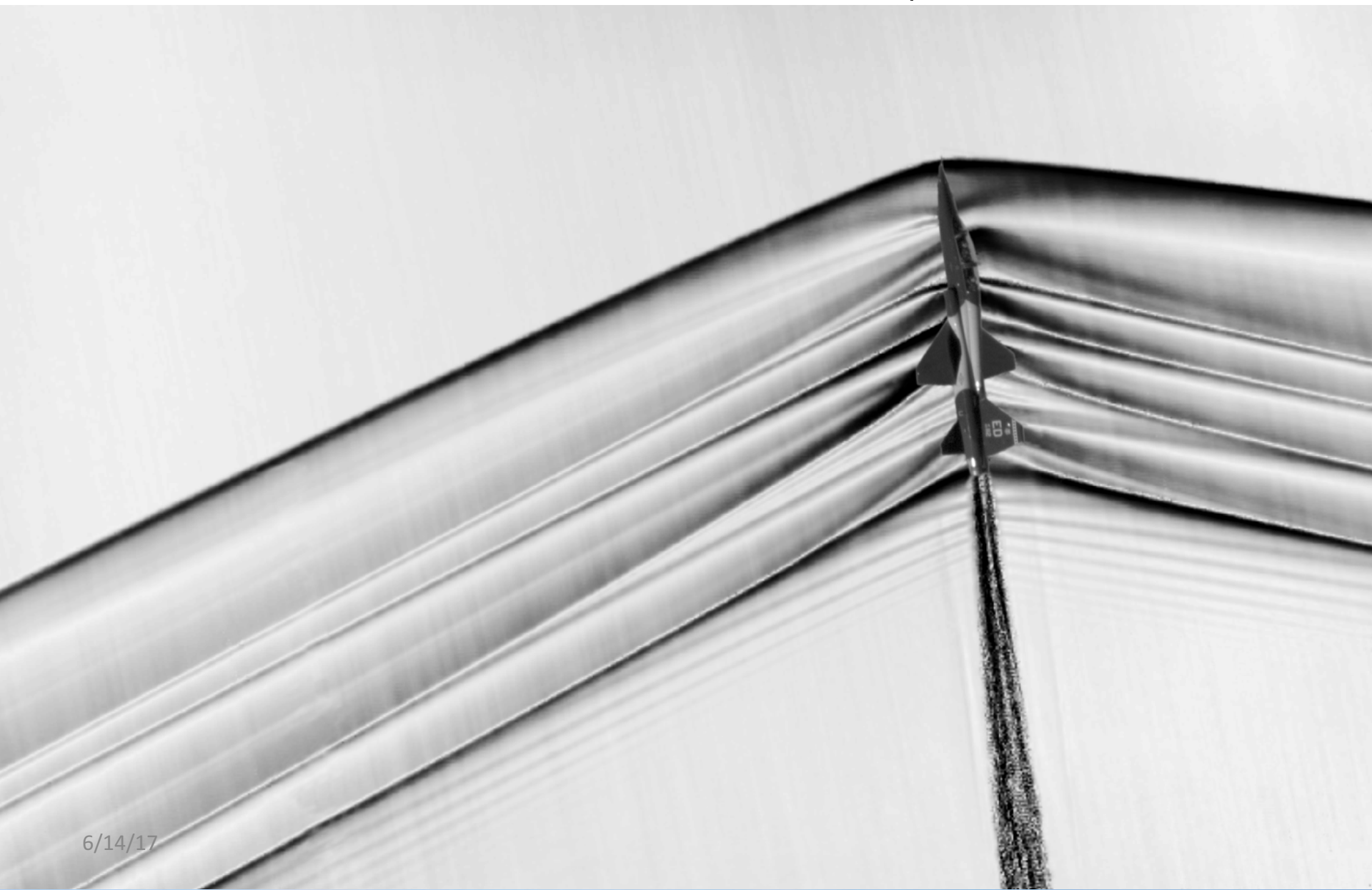



T-38 [AirBOS: Optical Flow, dy]

$M=1.05$; 2,000' separation; $\phi=0^\circ$

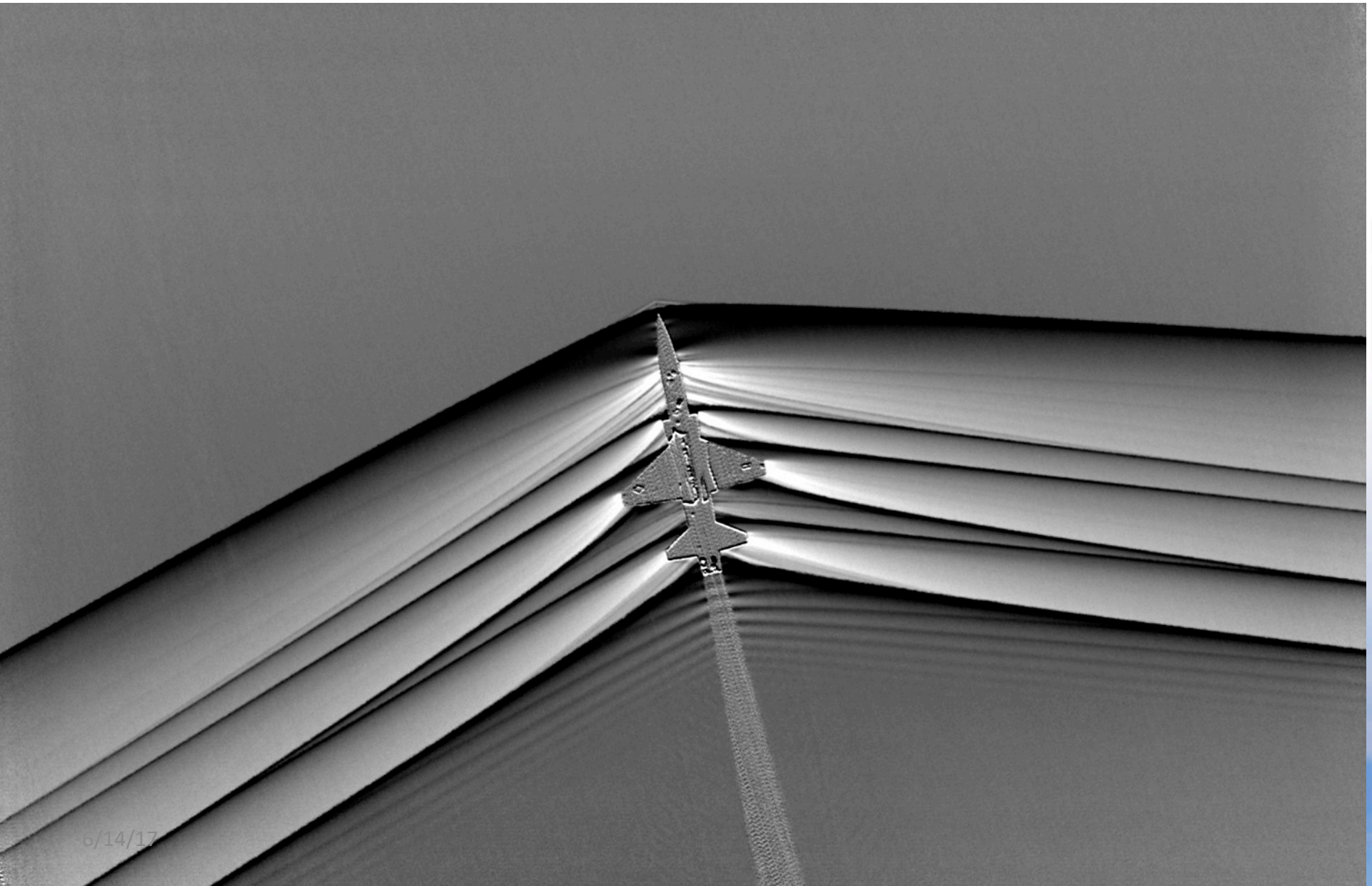



T-38 [AirBOS: Optical Flow, dx]

$M=1.05$; 2,000' separation; $\phi=0^\circ$

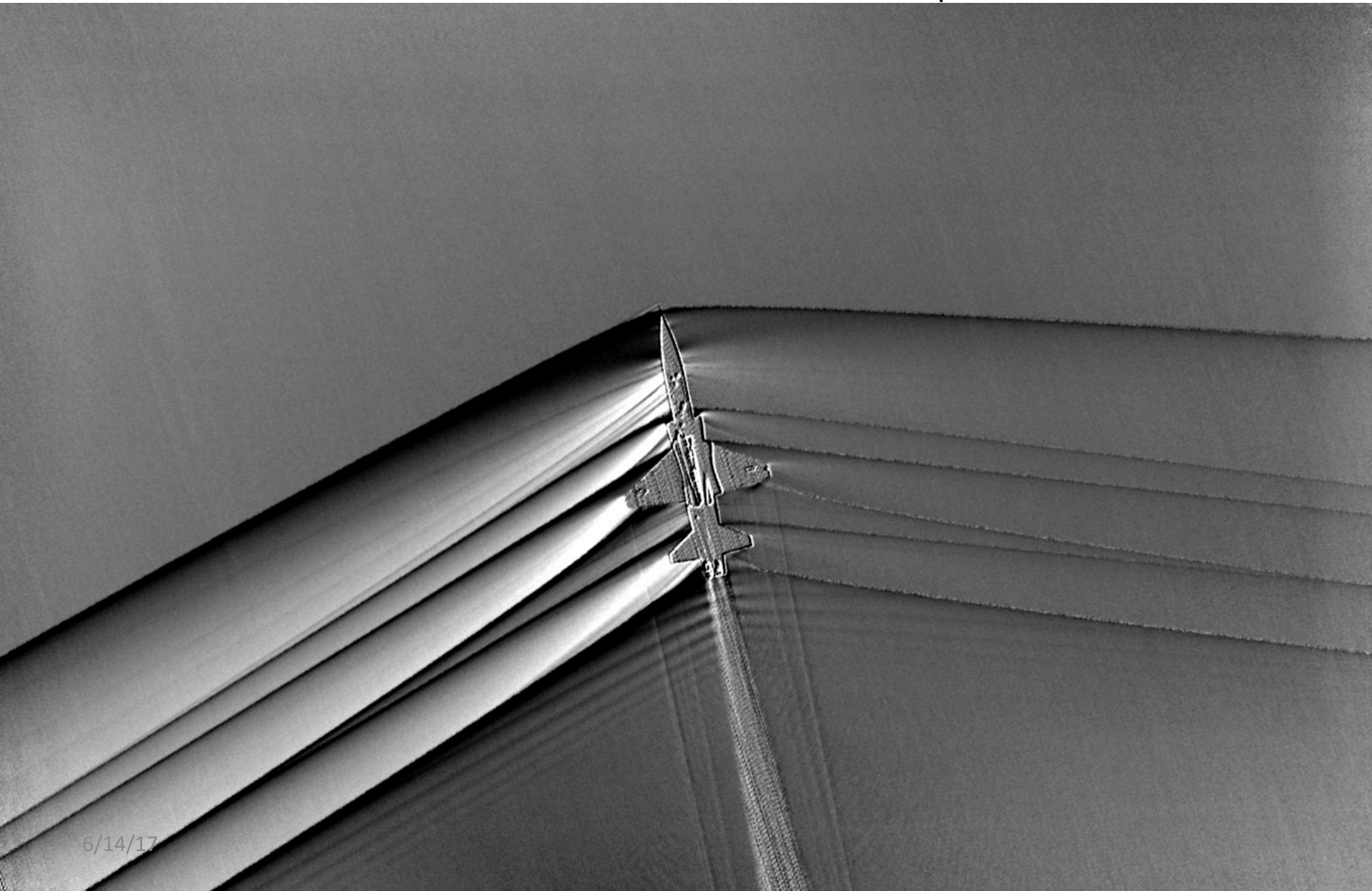



BOSCO Concept

- Uses narrow band optical filters to give the sun a textured appearance. The texture allows for the BOS method
- Advantages:
 - Full 2D measurement of a BOS system
 - Ability to image from below and to the side of the target aircraft

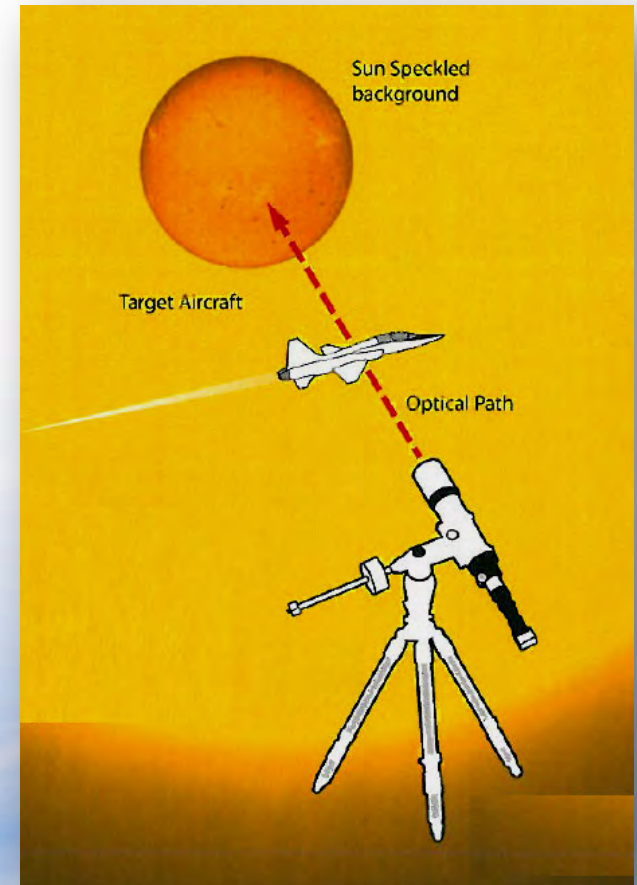
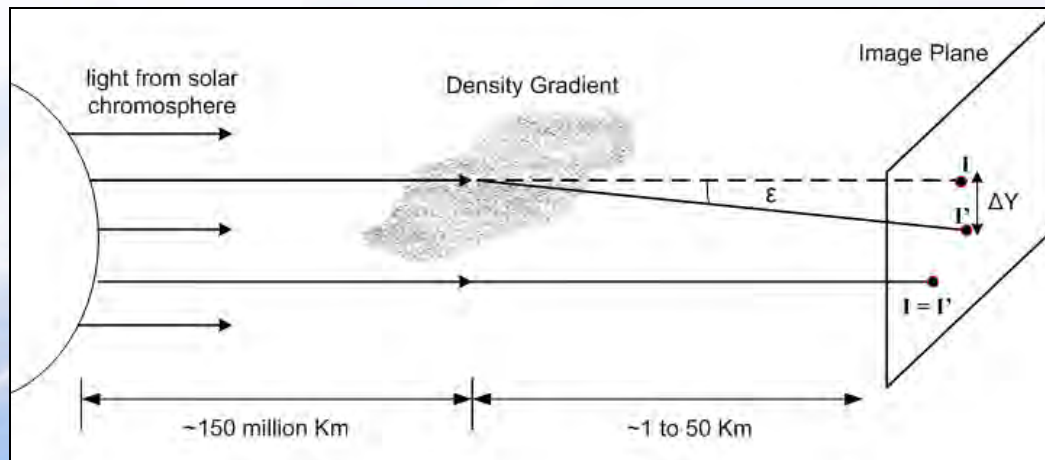



BOSCO Test Setup

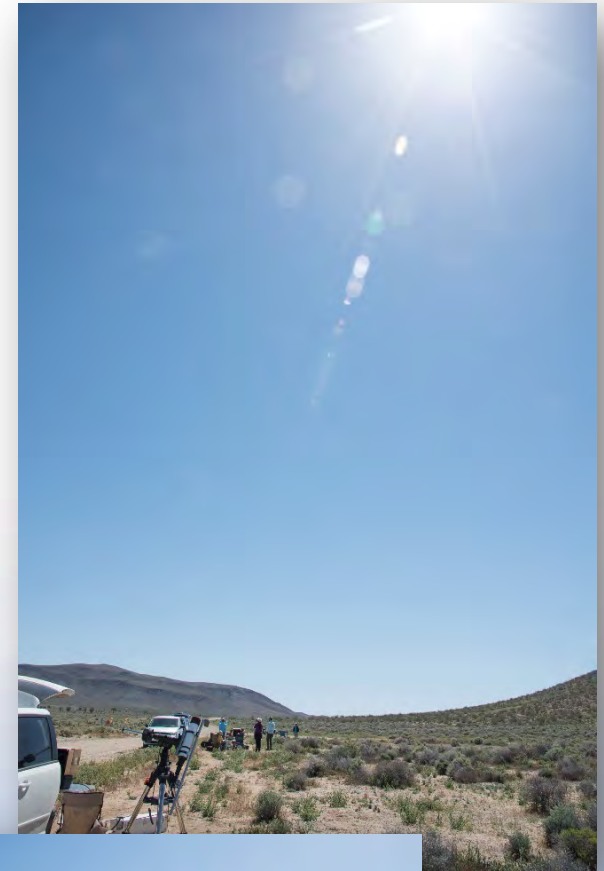

- Telescope fitted with CaK or H- α filter
- Equatorial mount with auto tracker
 - Manual fine adjustment
- High speed high definition camera
- Communication with target aircraft





BOSCO – Raw Image Sequence

H- α
filter

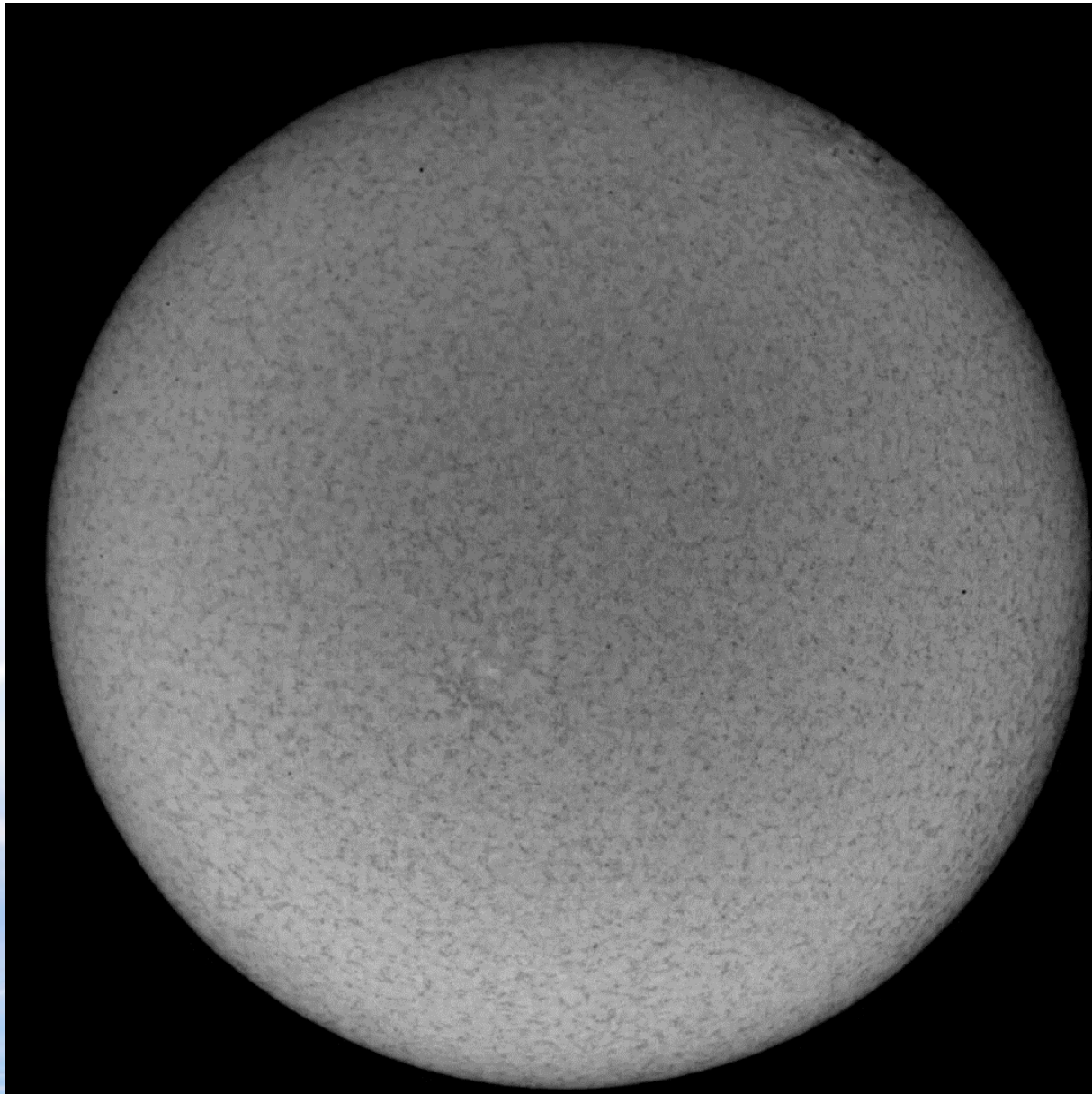

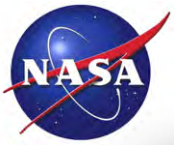

BOSCO Results

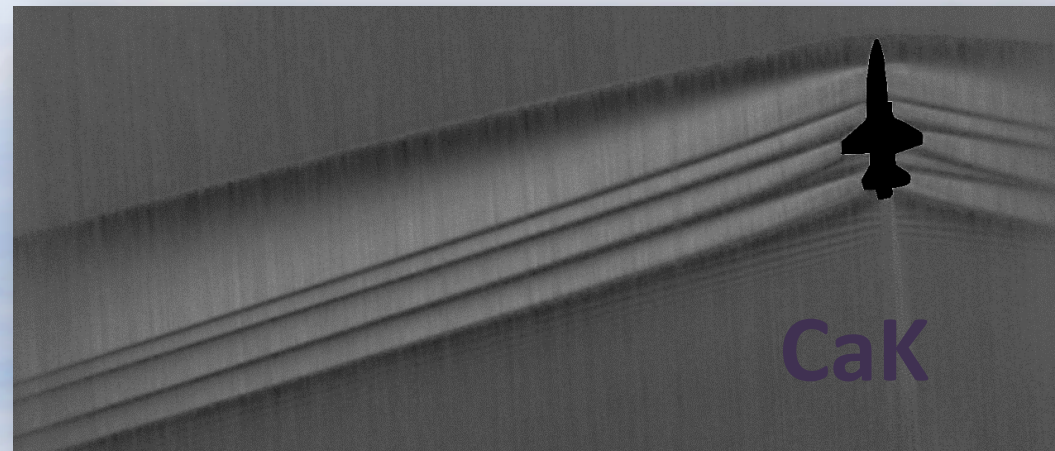
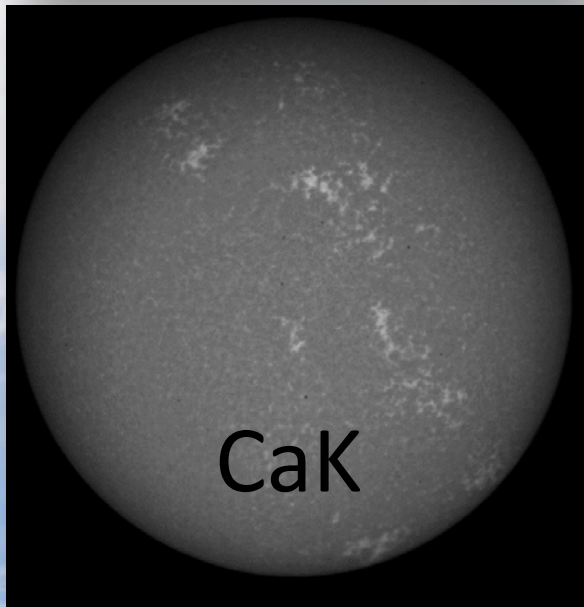
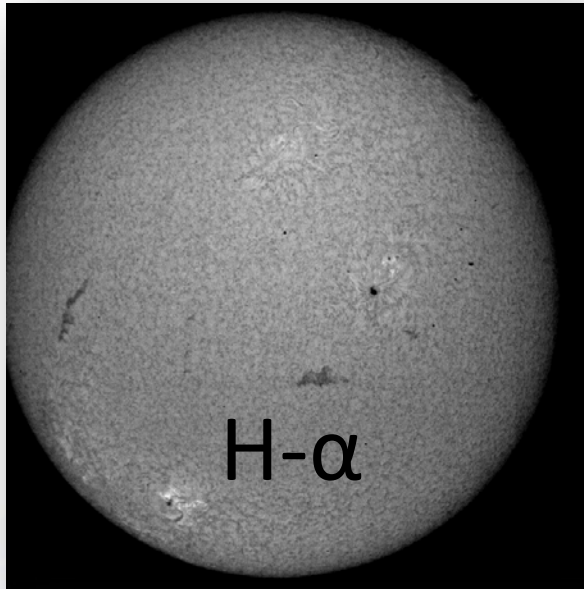



BOSCO-Results

- Aircraft banked at sun elevation angle for direct side view
 - Direct side view is of most interest for eventual imaging of low boom demonstrator

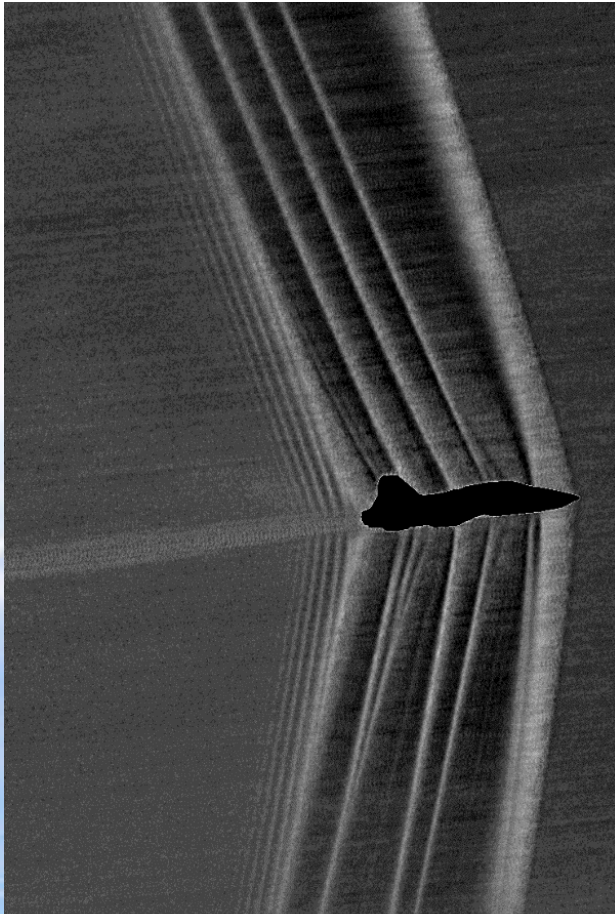

3 Image, wide field of view

The top and bottom images in the composite used the older CaKEBOS imagers, resulting in reduced resolution

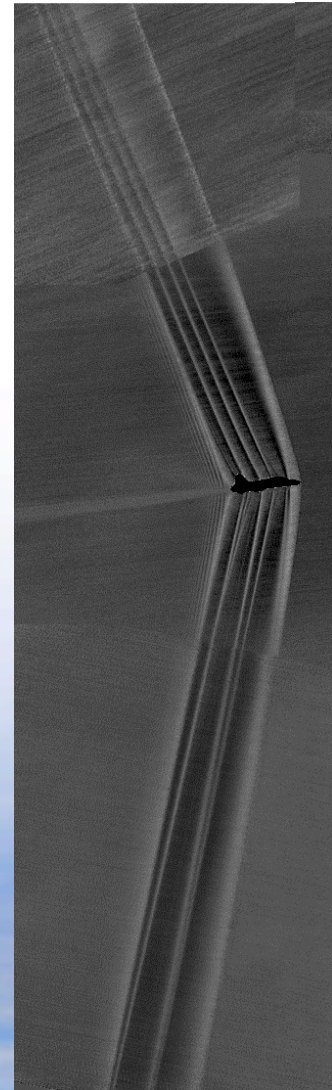



Flight Operations

- Test Operations
 - Multiple pilots: Face-to-face interaction between flights improved techniques and significantly increased productivity (L1)
- Ground Control
 - Efficiency and safety considerations (L2)
- Navigation / Maneuvering
 - First flights visual with guidance from sensor aircraft (large separation) [AirBOS]
 - Then handheld GPS (496) [AirBOS / BOSCO]
 - > T-38 had onboard system
 - Atmospheric conditions created challenges
 - > Cross winds (L7)
 - > Visibility
- Future Ops
 - Air-to-air GPS needed for tighter tolerances and for offset positioning



First AirBOS Flights



Later Flights, AirBOS & BOSCO



AirBOS Test Operations

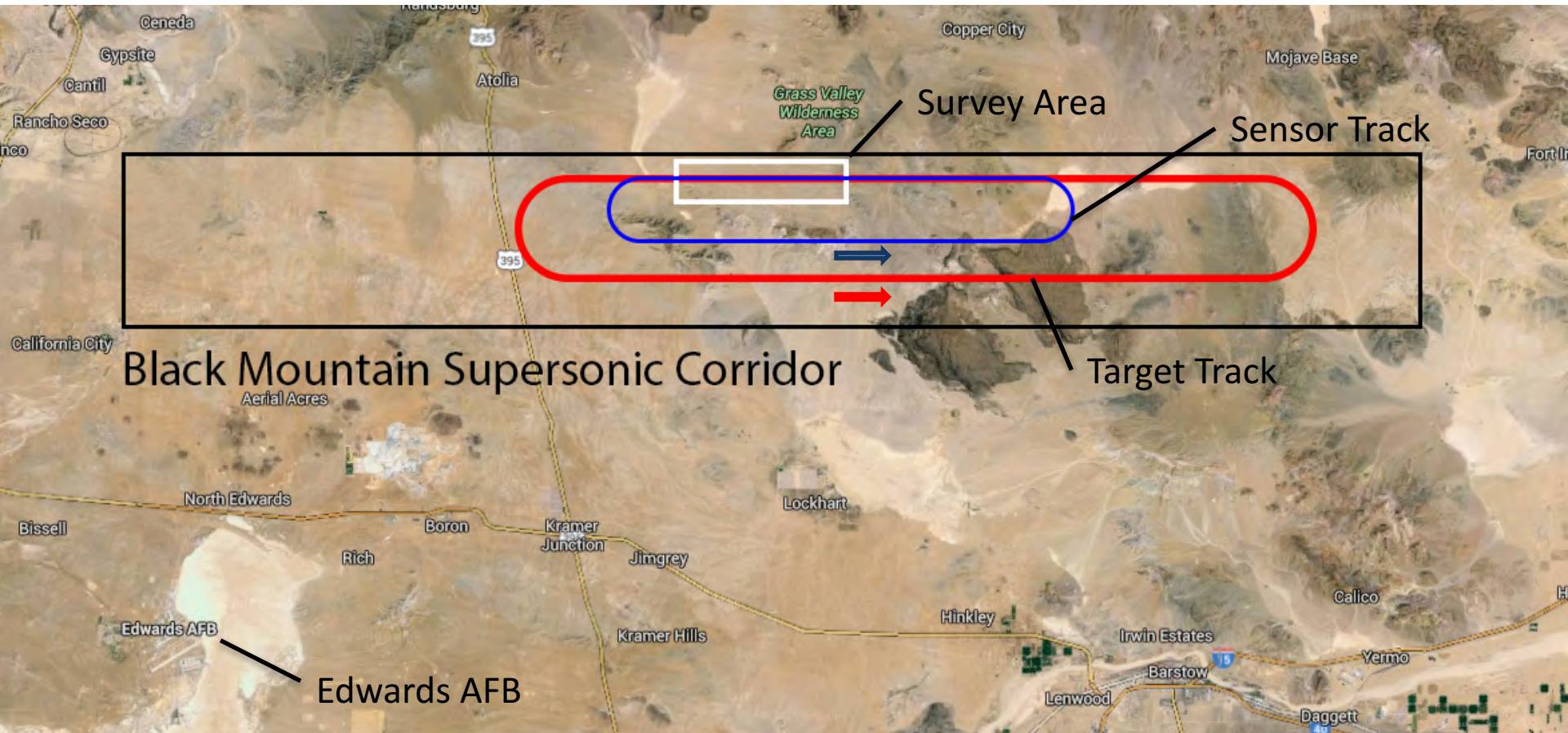

Timing was important for efficiency

- Target went to best endurance on "downwind" leg
- Sensor would report status to control room
- Turn in by sensor and target called by controller
- Fly through box was 178 feet wide and 284 feet long (closest)



BOSCO Test Operations

- Aircraft waypoints were calculated based on time of eclipse, ground position of the imager, and desired altitude of the aircraft.
- Course of the aircraft followed the sun direction across the sky, and flights occurred near the maximum solar elevation angle, to minimize the need for accurate waypoint timing.
- Range from the imager to the aircraft increases as sun elevation decreases and as altitude difference between the imager and aircraft increases

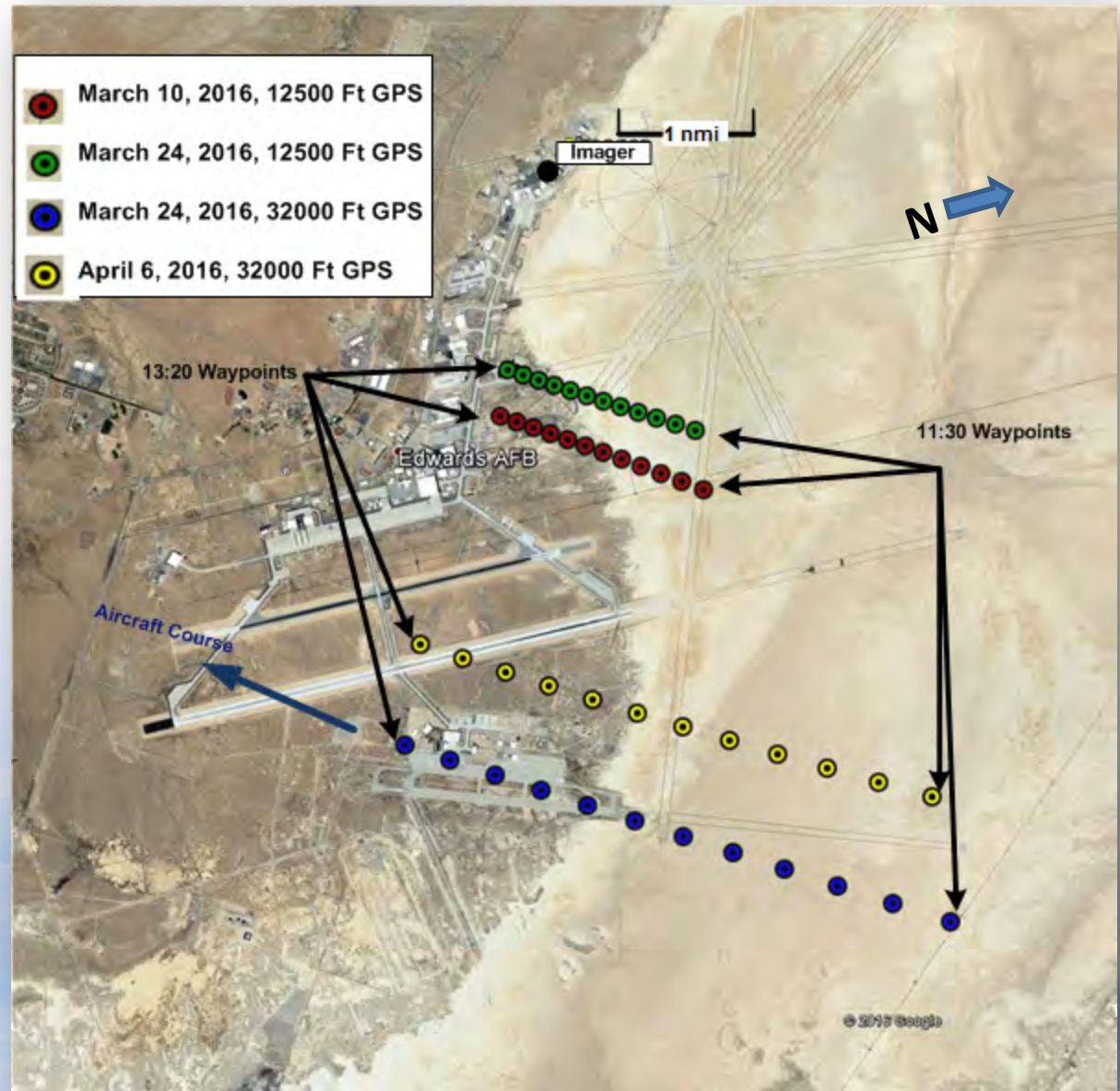

Ground Control



Remote control during BOSCO



Control Room during AirBOS

Control room and field control not necessary but (L2):

- Improved efficiency
- Provided better spatial awareness
- Added safety especially with multiple aircraft

Using knowledgeable pilot as controller (L3):

- Improved efficiency and SA even further
- Knew what pilots were thinking and what info they needed
- Was able to pass on real time assessment when things weren't going as planned



GPS Cockpit Installation

F-15 Installation



F-18 Installation



- Hard mounted Garmin 496 used for F-18 and F-15 (L4)*
 - Worked OK
 - Acceptable scan
 - Acceptable alignment
- Integrated system in T-38
 - Worked very well
 - Easier scan
 - Alignment very accurate



* Sometimes simple solutions work (handheld GPS)

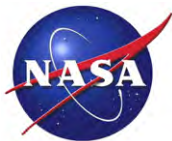

T-38 HSD -> PFR

Rough Alignment - HSD



Fine Alignment - PFR





Air-to-air GPS

- Future operations will require air-to-air differential GPS for guidance

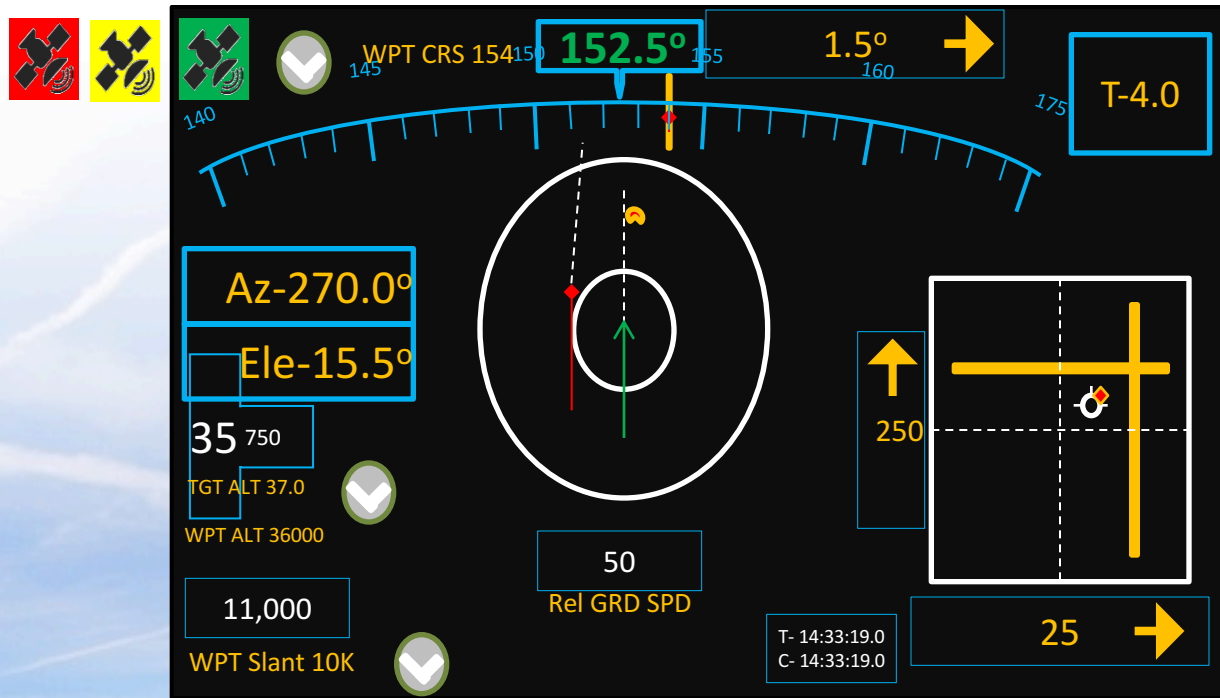
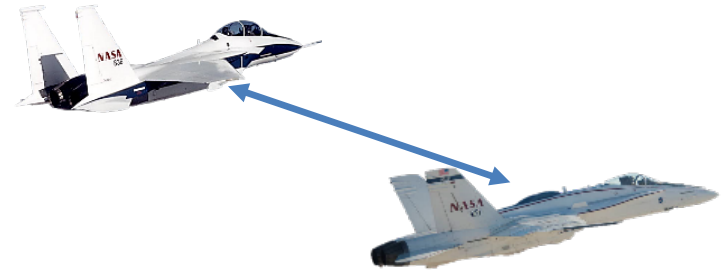



Summary

- AirBOS allows very detailed schlieren images
 - Currently need aggressive maneuvering for side shot
- Solar chromosphere works well as a background for BOS
 - Both Hydrogen – α line and Calcium-K line produced good results
 - > H- α superior for BOS imaging
- Flight operations evolved into well orchestrated operations
- GPS was necessary for satisfactory alignment
- Air-to-air GPS required for future ops

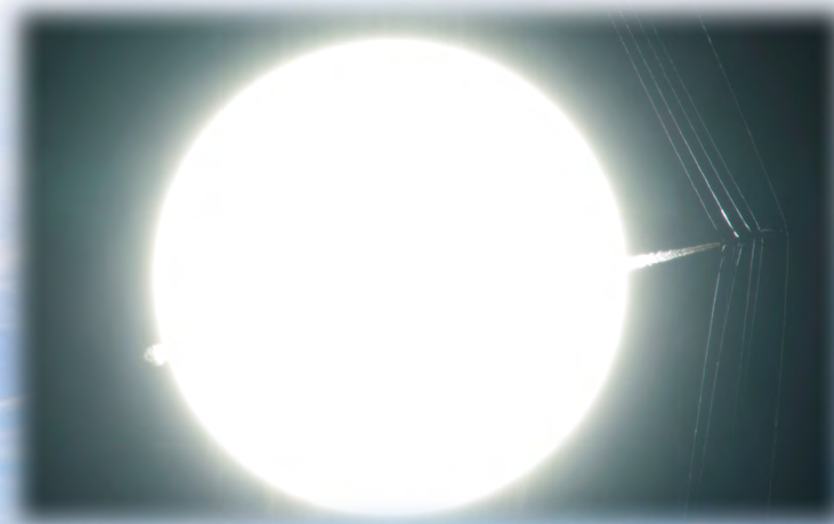



Lessons Learned

1. Face-to-face feedback from pilot to pilot right after it was flown (including practice flights) helped the following pilot improve on the technique (true for F-18/F-15/T-38 targets and King Air).
2. Control Room while not necessary improved SA and efficiency. Single point communications with the ground (or camera aircraft) and the target aircraft. Count down was pivotal when trying to do some of the timing, also allowed for the accuracy needed. Pilot could assess the rate of offset by the audio of the count down. Allowed part for the crosscheck to be audio vs visual. Also added an extra layer of safety when operating two and three aircraft simultaneously. Provided real time assessment of what was working and not, and provided recommendations when things were not working as planned.
3. Having a knowledgeable pilot as the controller in the control room made for even more effective and efficient passes. The controller then knew what the pilots were thinking and what information was needed and when. They could provide better SA and also useful ideas to improve the runs.
4. Improved positioning of the data on the 496 allowed a more efficient crosscheck...pivotal when trying to make small changes at high speed. The two most important pieces of data were right next to each other (GPS alt and cross track) and were also close to the other aircraft provided data (Mach #, heading).



More Lessons Learned, Though Not Specifically Mentioned

5. Lots of things needed to be exact, so it was helpful to remove any variables or drive outside factors to smaller numbers. Crafting ways to account for small errors ahead of time was important. Example was adjusting flight path close to sun trajectory for BOSCO runs, then small errors in eclipse time were compensated.
6. Having well scripted and briefed flights reduced a lot of uncertainty
7. Winds (mainly cross winds) at altitude provided a real challenge. Crabbing, lateral drift, and attitude of sensor plane combined for failed passes in some AirBOS runs. Experience helped to better correct for cross winds.
8. Practice the things you can. Practice provided a lot of insight that made the actual flight test much more efficient and reduced uncertainty.
9. Right size team and mix. Enough pilots (and engineers) to provide different ways of approaching tasks (learned from each other), but not so many so as each does not get sufficient time to master maneuvers and test flow.
10. Sometimes luck was as valuable as skill. Even passes that didn't work out as planned often yielded interesting results. Examples: roll in field of view, normal shock ahead of aircraft when got too slow, etc.