



A Review of the Proposed K_{Isi} Offset-Secant Method for Size-Independent Linear-Elastic Toughness Evaluation

Mark James¹
Doug Wells²
Phillip Allen²
Kim Wallin³

¹ Arconic Technology Center

² NASA MSFC/Damage Tolerance Assessment Branch

³ VTT Nuclear Safety, VTT, Finland



Contents

- Size Dependence in K_{Ic} per E399
- The K_{Isi} Proposal
- Questions of Linear Elasticity and Plasticity
- An Evaluation of K_{Isi} for Plasticity
 - Analytical Assessments
 - Model Scaling
 - Size independent parameters
 - Material Space
- Results
- Conclusions



Size Dependence in K_{Ic} per E399:

- Toughness test results for K_{Ic} from ASTM E399 are dependent upon specimen size for Type I force-displacement curves due to R-curve effects.
 - Wallin, K. R. W., “Critical Assessment of ASTM E399.” *Fatigue and Fracture Mechanics: 34th Volume, ASTM STP 1461*, S.R. Daniewicz, J.C. Newman, and K.H. Schwalbe, Eds, ASTM International, 2004.

E399, Type I Assessment:

- 5% offset secant
- Assumes all compliance change is due to crack extension
- Corresponds to crack extension equal to approximately 2% of the specimen’s original ligament, b_o .

Measured K_{Ic} is a function of specimen size based on b_o

Type I, Rising R-Curve Behavior

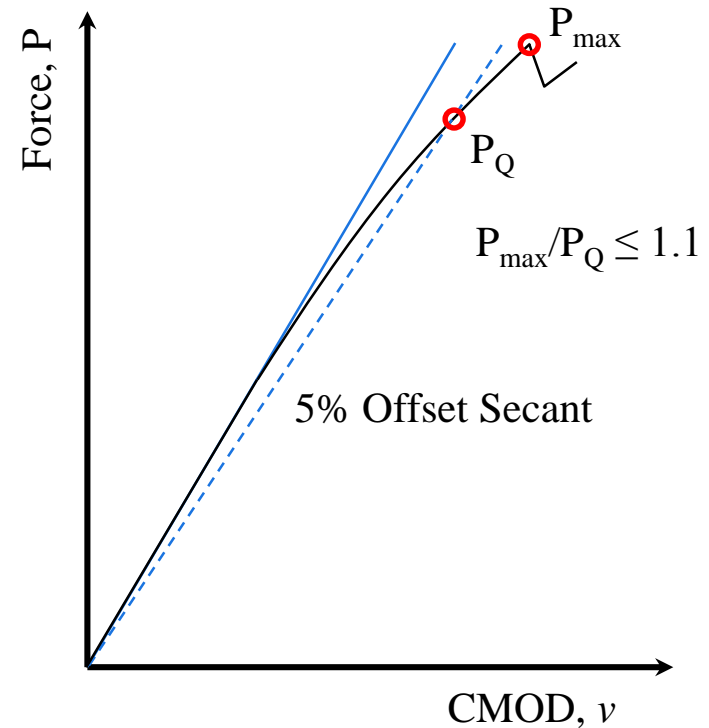



The K_{Isi} Proposal

A proposed toughness measure without size dependence: K_{Isi} (Wallin, 2004)

- A new optional toughness parameter, K_{Isi} , does **not** replace K_{Ic} in E399
- Utilizes an offset secant that is a function of the specimen size (b_o)
- Targets a consistent 0.5mm of predicted crack extension.
- Reduces the specimen size dependence in the toughness result

Two Proposed validity changes:

1. Ligament requirement

From: $b_o \geq 2.5(K/\sigma_{ys})^2$

To: $b_o \geq 1.1(K/\sigma_{ys})^2$.

2. Remove requirement that $P_{max}/P_Q \leq 1.1$

This methodology also assumes that all compliance change is due to crack extension.

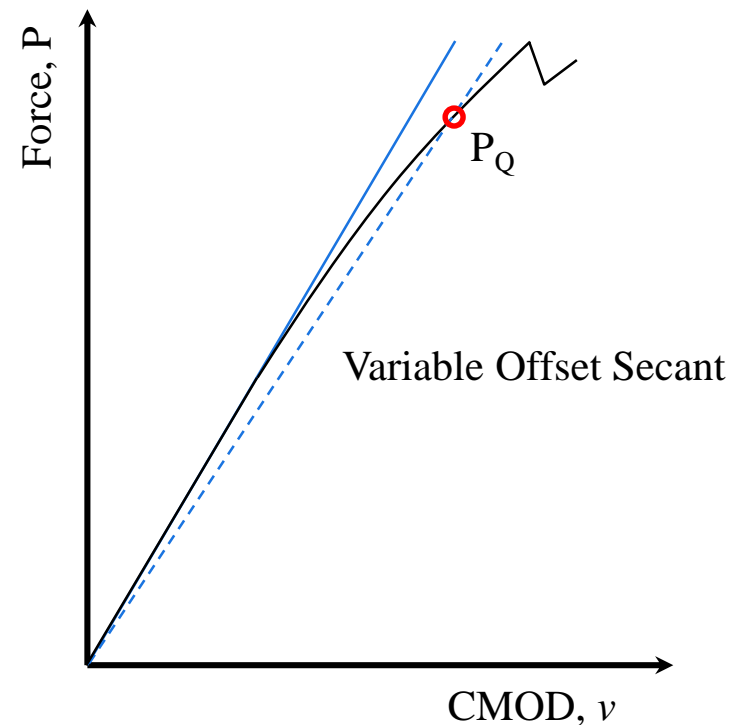



The K_{Isi} Proposal, Continued

The K_{Isi} Variable Secant

Change in compliance (ΔC):

- Percent increase in compliance (or percent decrease in slope) of the force vs. displacement trace with respect to the initial linear portion of test record

$$\Delta C = \Delta C_{crack\ ext} + \Delta C_{plasticity} + \Delta C_{experimental\ error}$$

- For E399 K_{Ic} assessment, the offset secant $\Delta C = 5\%$ for all specimens.
- For K_{Isi} , ΔC_{si} is proposed to follow this convention for the C(T) specimen:

$$\Delta C_{si} = 135/(W-a) \text{ (for mm dimensions)}$$

- For common E399 inch-sized specimens with $a/W = 0.5$:

$$W = 25.4 \text{ mm (1 inch)}, \quad \Delta C_{si} = 10.6\%$$

$$W = 50.8 \text{ mm (2 inch)}, \quad \Delta C_{si} = 5.3\%$$

$$W = 101.6 \text{ mm (4 inch)}, \quad \Delta C_{si} = 2.7\%$$

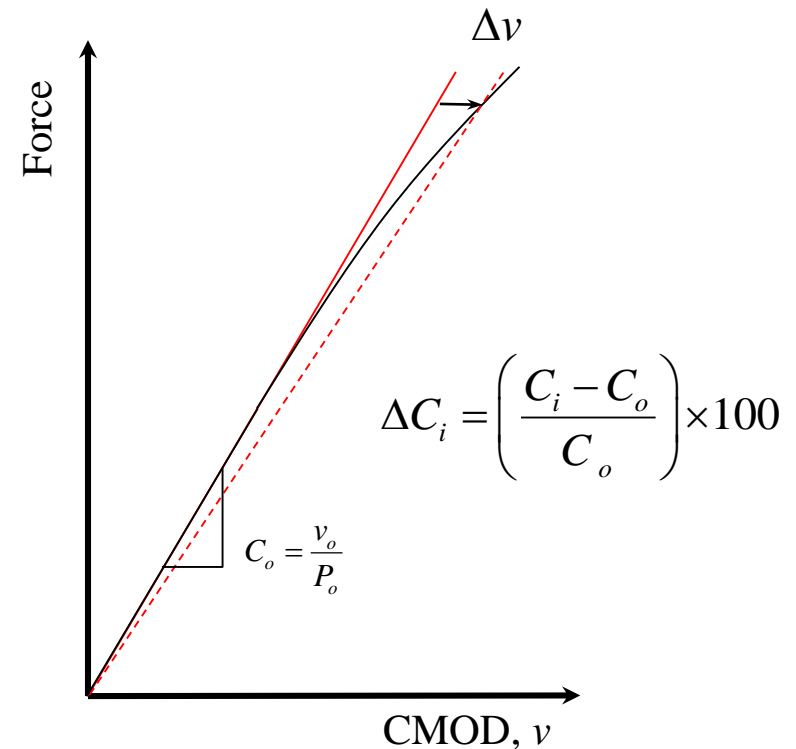

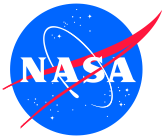

Questions of Linear-Elasticity and Plasticity

- Consider the coefficient (2.5) in the E399 ligament requirement, $b_o \geq 2.5(K/\sigma_{ys})^2$ as a variable, M_K , such that $M_K = b_o(\sigma_{ys}/K)^2$
- In the $K_{I_{si}}$ method, the proposed change from $M_K = 2.5$ to $M_K = 1.1$ allows a larger crack tip plastic zone size, r_p , relative to the ligament, b_o .

If $r_p \approx 0.15 (K/\sigma_{ys})^2$ [Yang, 1991]*

Then $M_K \approx 0.15 b_o / r_p$

At $M_K = 2.5$, $r_p / b_o \approx 6\%$

At $M_K = 1.1$, $r_p / b_o \approx 14\%$

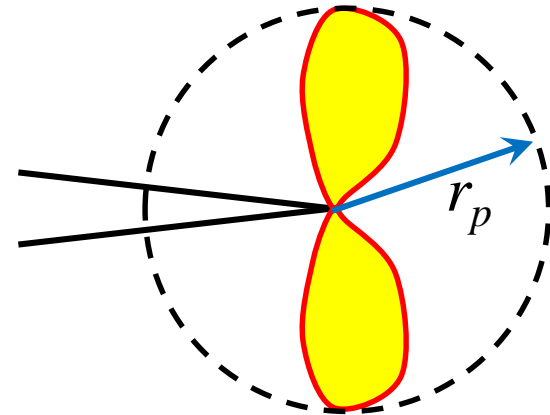

- Extensive experimental data review (Wallin 2004) confirms $M_K = 1.1$ maintains LEFM conditions for valid K fields.

Primary question:

At $M_K = 1.1$, with valid LEFM conditions, is compliance change in the test record due to plasticity ($\Delta C_{plasticity}$) still negligible?



An Evaluation of $K_{I,si}$ for Plasticity

Objectives of current study:

1. Determine if compliance change in the force (P) versus CMOD (v) record due to plasticity ($\Delta C_{plasticity}$) makes the $K_{I,si}$ variable offset secant method incompatible with $M_K = 1.1$.

➡ The method is incompatible if $\Delta C_{plasticity} \geq \Delta C_{si}$ with $M_K \geq 1.1$

2. Confirm assumptions that linear elastic-conditions prevail at $M_K = 1.1$ such that the crack tip fields remain K -dominant.

Approach:

1. Evaluate ΔC in P - v record with finite element models over a substantial material property space as deformation increases to $M_K = 1.1$

➡ There is no $\Delta C_{crack_extension}$ contribution in the finite element model

2. Evaluate the contribution of plasticity to crack driving force (through $K_{Jplastic}$) as deformation increases to $M_K = 1.1$.



One Model, Many Materials

- Use of non-dimensional parameters (ΔC , M_K) throughout assessment = scalability
- One FE model provides solution for all specimen sizes of proportional geometry
- Chose C(T) with $W/B = 4$ and $a/W = 0.5$
 - $W/B = 4$ has greatest $\Delta C_{plasticity}$ effects for E399 range $2 \leq W/B \leq 4$
 - Results shown for plane-sided
 - Side grooves were also evaluated

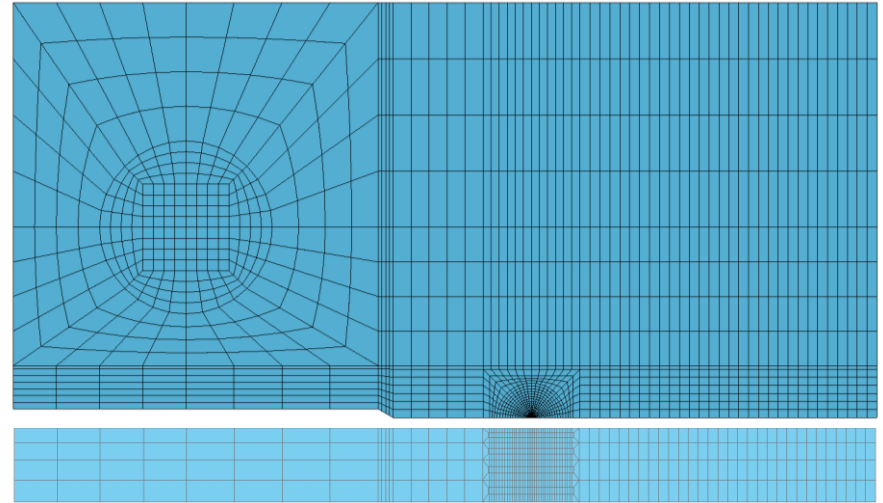

Model:

- C(T) model run with WARP3D v16.2.7
- Mesh generated using FEACrack
- $\frac{1}{4}$ symmetric, 56863 nodes, 12305 elements (20 node hex, small strain)
- Crack tip:
 - Collapsed elements, untied duplicate nodes, 15 domains, Type D for bulk average J
- Forces applied at center of pin mesh
- Pin rotation allowed, elastic pin material

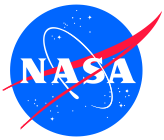

One Model, Many Materials

Material Space

Material flow properties are input as a table of stress and plastic strain pairs that follow the linear + power law formulation:

$$\sigma_o = E\varepsilon_o$$

$$\sigma = E\varepsilon \text{ for } \sigma \leq \sigma_o$$

$$\sigma = \sigma_o \left(\frac{\varepsilon}{\varepsilon_o} \right)^{\frac{1}{n}} \text{ for } \sigma > \sigma_o$$

In all cases, $\sigma_o = 1$
 ε_o is calculated at 0.2% plastic strain

Stiffness to Proportional Limit Ratio, E/σ_o

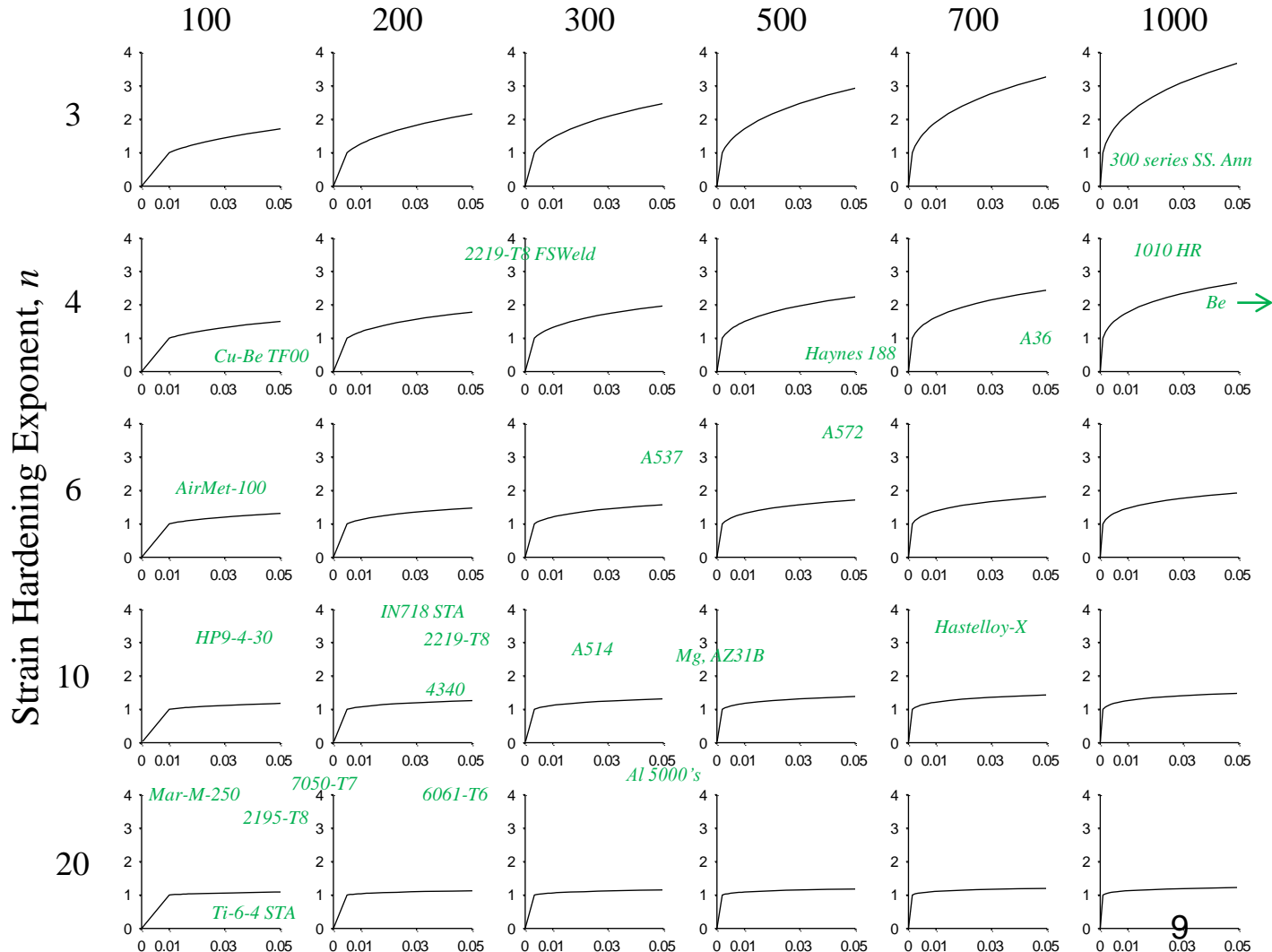



Results: Illustration of Analysis

- E399 test for K_{Ic}
- $\Delta C = 5\%$
- $M_K \geq 2.5$

For valid K_{Ic} test:

$$\Delta C \geq 5\%$$

While

$$M_K \geq 2.5$$

- Ensures crack extension is present because $\Delta C_{plasticity} < 5\%$

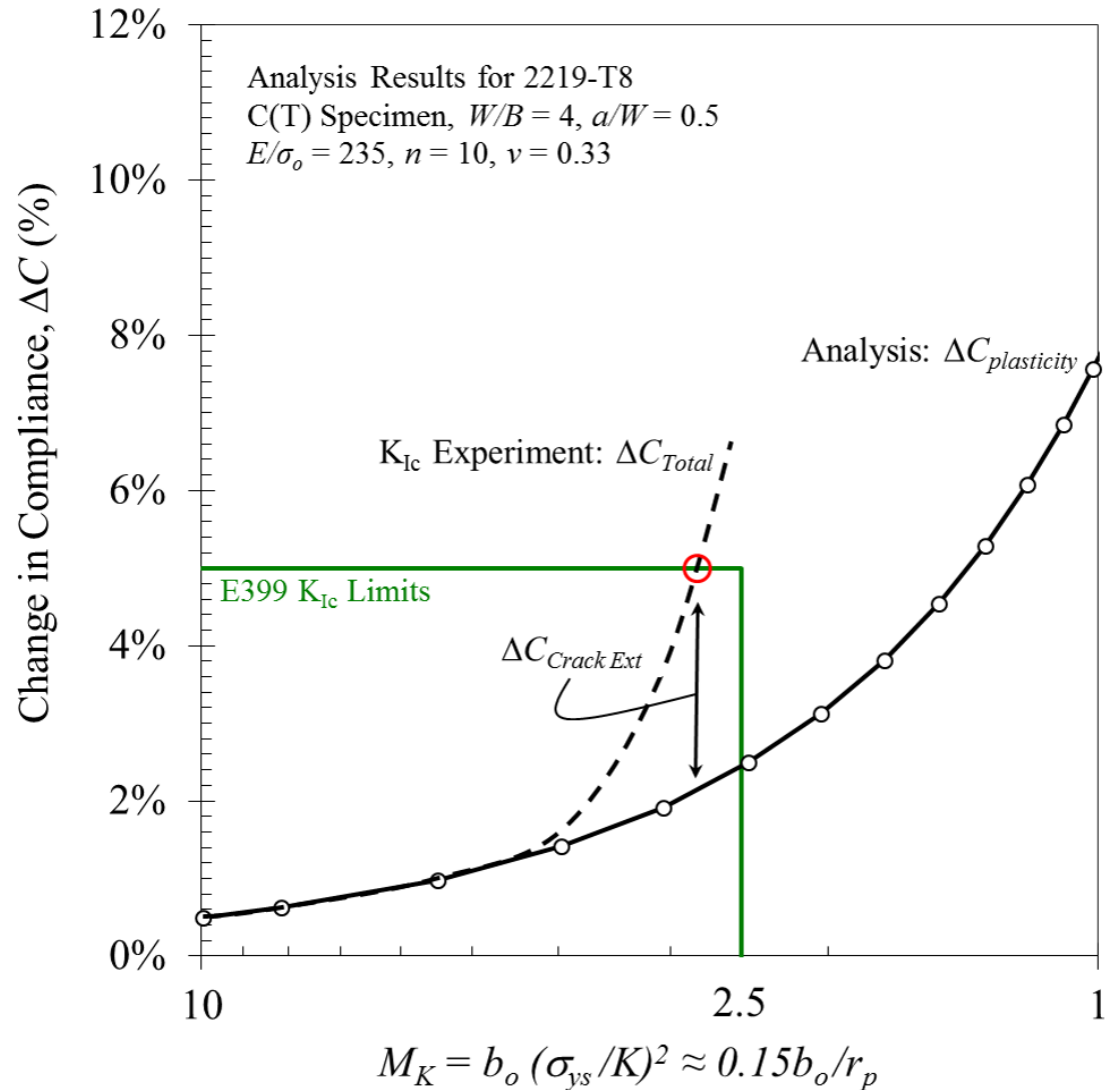



Results: K_{Isi} Trouble at $M_K = 1.1$

- ΔC_{si} shown for $W = 25, 50, 75, 100,$ and 125mm
- $M_K = 1.1$ limit shown

Proposed K_{Isi} method:

$$\Delta C \geq \Delta C_{si}$$

While

$$M_K \geq 1.1$$

Issue:

- $\Delta C_{plasticity} > \Delta C_{si}$
With $M_K \geq 1.1$
- Does not ensure crack extension!
- Confirmation:
- Plastic contribution to KJ is small, LEFM is good to $M_K = 1.1$!

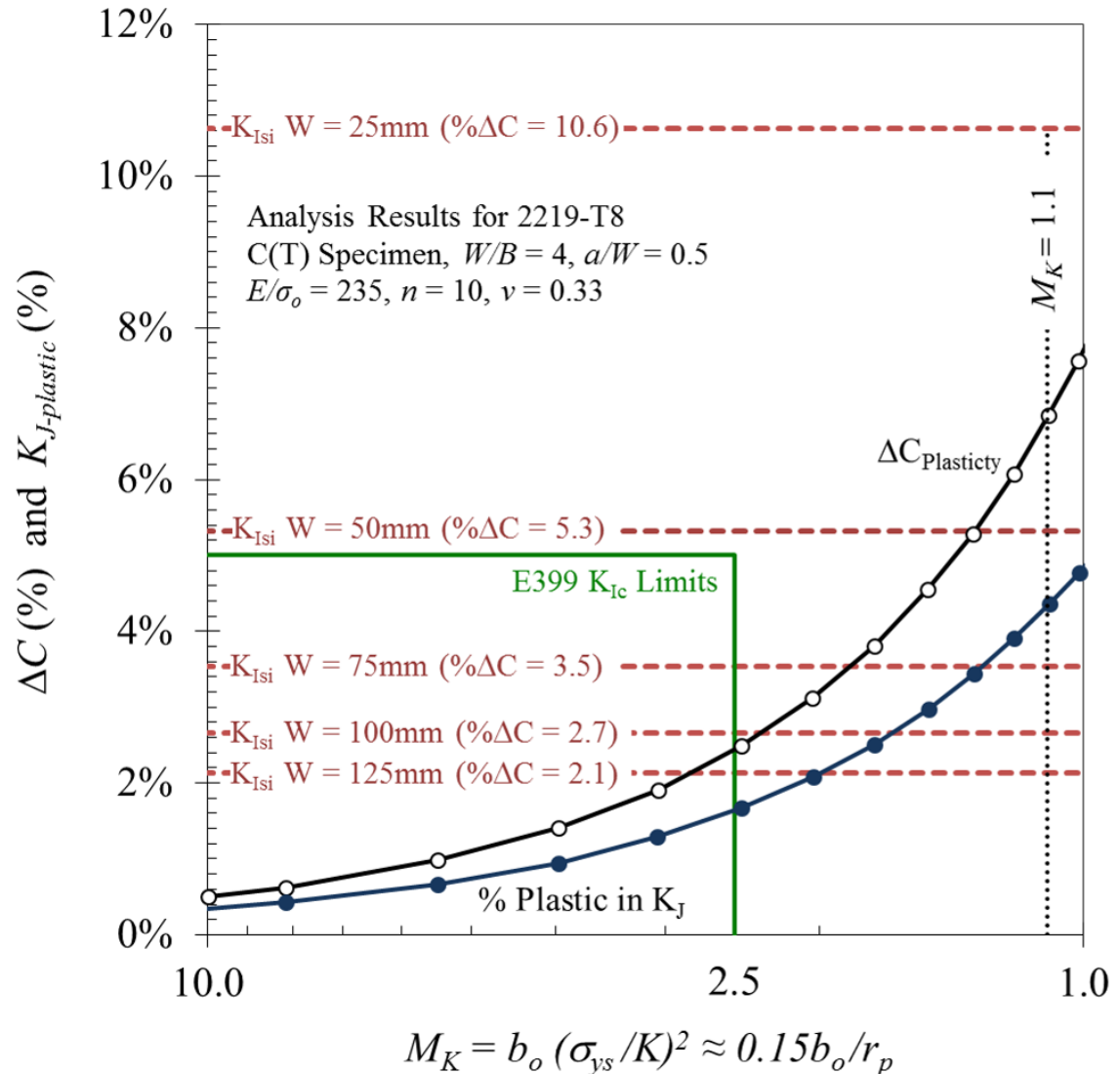



Results: Material Influence

- Plasticity effects on compliance reflect plastic contribution to K_J
- Influence of strain hardening depends upon E/σ_0 ratio
- Low hardening ($n = 20$) eliminates effects of E/σ_0 ratio

$\% \Delta C$ at $M_K = 1.1$
All Materials

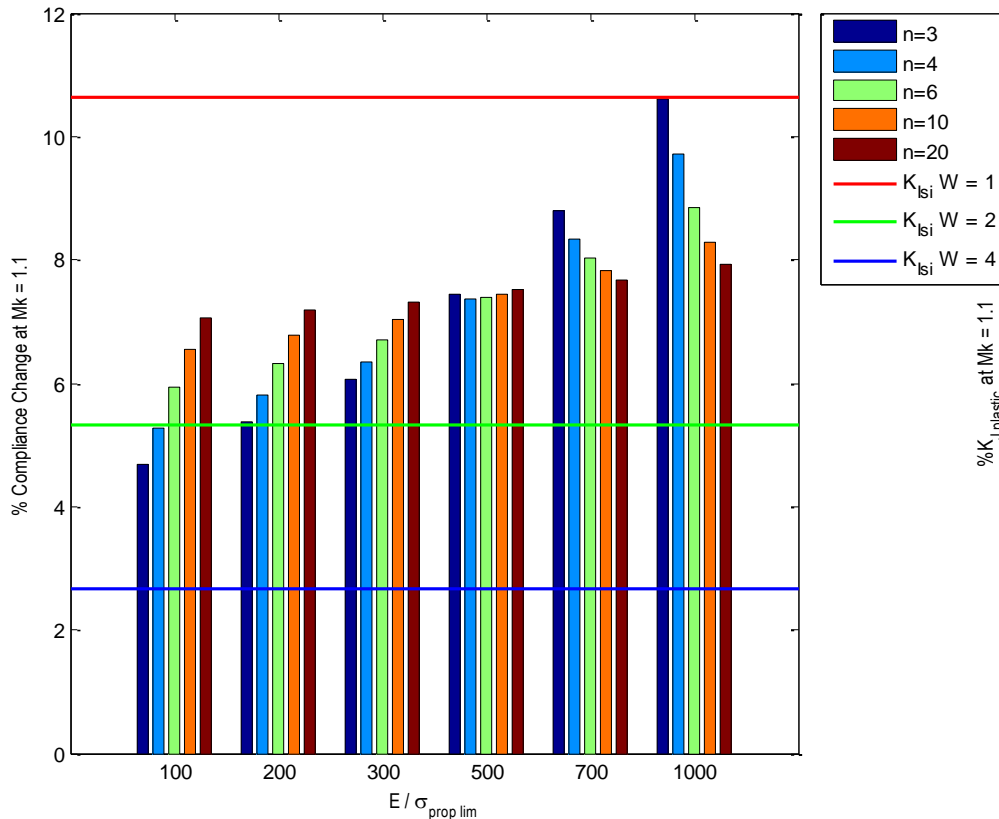

Plastic Contribution to K_J at $M_K = 1.1$
All Materials

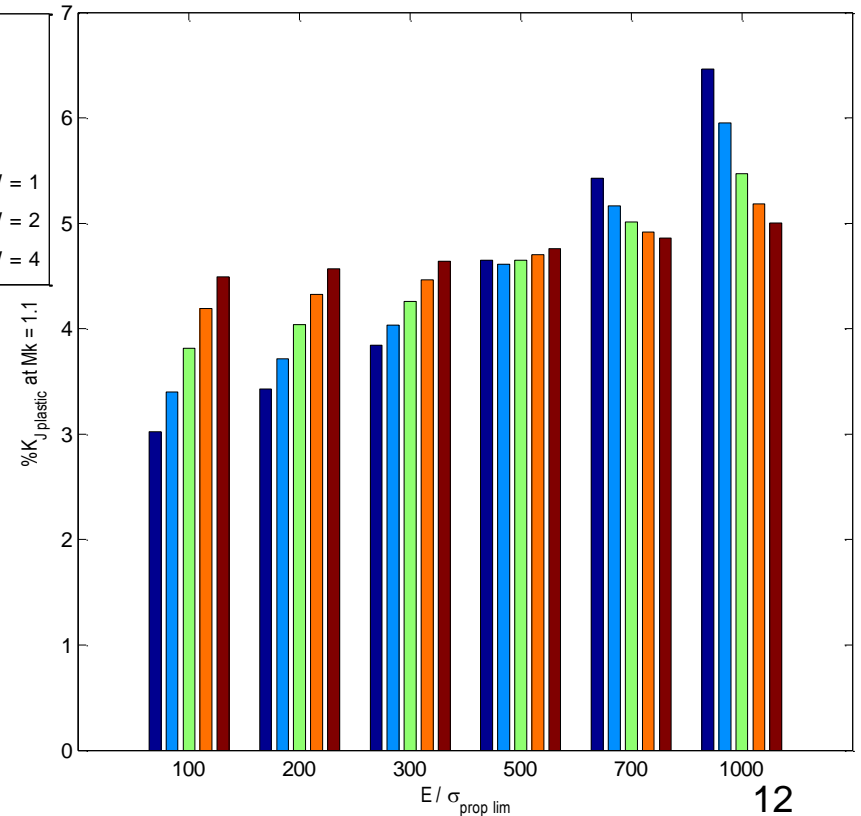



Conclusions

Proposed remedy to limit K_{Isi} deformation

Recast the K_{Isi} deformation limit at a fixed plastic zone size accounts for this effect:

$$\left(\frac{K_{Isi}}{\sigma_{ys}} \right)^2 < 12.5mm \quad \text{Or approximately, } r_p < 1.9 \text{ mm}$$

In the context of M_K :

$$M_K = \frac{b_o \sigma_{ys}^2}{K^2} \quad \therefore \left(\frac{K_{Isi}}{\sigma_{ys}} \right)^2 = \frac{b_o}{M_K} < 12.5mm$$

$$M_K > \frac{b_o}{12.5mm}$$



Conclusions

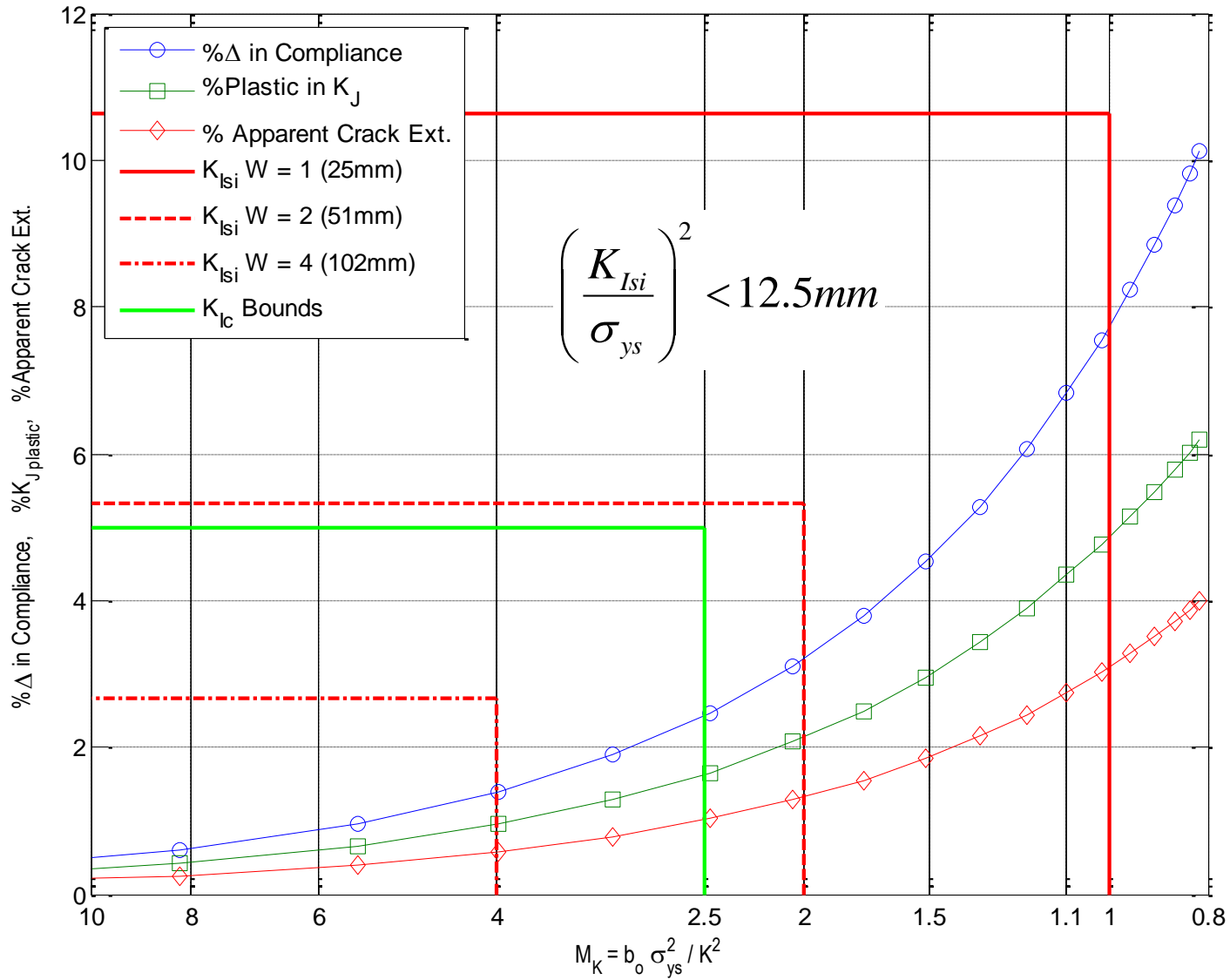



Conclusions

1. The use of $M_K = 1.1$ creates sufficient compliance change due to plasticity to result in potential misidentification of toughness prior to crack extension for specimens larger than $W = 25$ mm.
 - Proposed remedy is to make M_K a function of specimen size with $M_K = b_o / 12.5\text{mm}$
2. The increase in the allowable deformation to $M_K = 1.1$ does not invalidate the LEFM assumptions for a valid K field.

Forward Work

Continue revisions to $K_{I_{si}}$ content for E399

Conduct experimental assessment of $K_{I_{si}}$ for size independence and realized crack extension at the ΔC_{si} limit



Back-up

- Model compliance confirmation
- $W/B = 4$ versus $W/B = 2$
- 3D versus Plane Strain Effects
- Side Groove Effect for $W/B = 4$



Model Compliance Confirmation and 3D effects enhanced by $W/B = 4$

To confirm the quality of the force versus CMOD results from the FE model, the results of a plane strain version of the model (identical except for side constraints) and the 3D version with $W/B = 4$ were compared and the results evaluated with the compliance relations in E399 (Eqs A5.3 and A5.4) to see how accurately the known ($a/W=0.5$) model crack lengths were predicted. The model uses the normalized 2219 material parameters.

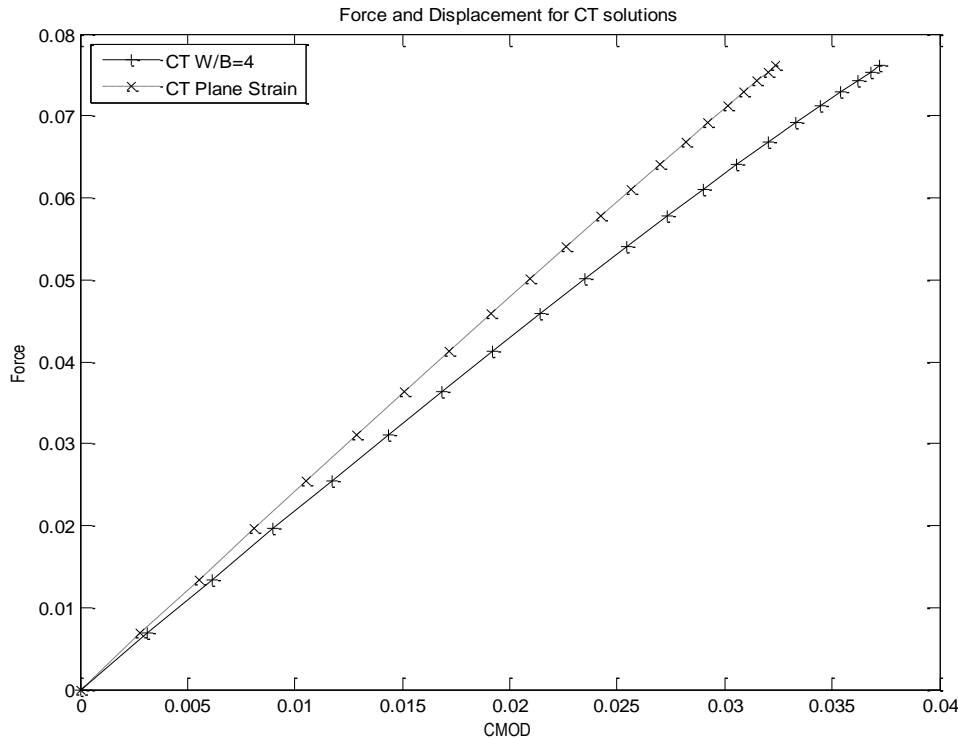

	E399	Plane ϵ	$W/B = 4$
a_o/W	0.500*	0.498	0.522
K at P = 0.0761	1.04	1.06	1.14

* Given
 a_o/W compared at first load step

Note that the 3D result reflects significantly increased compliance, compliance change, and higher deformations (higher K) for a given applied force. See following slides for deformation comparison charts.



Evaluation of W/B Ratio

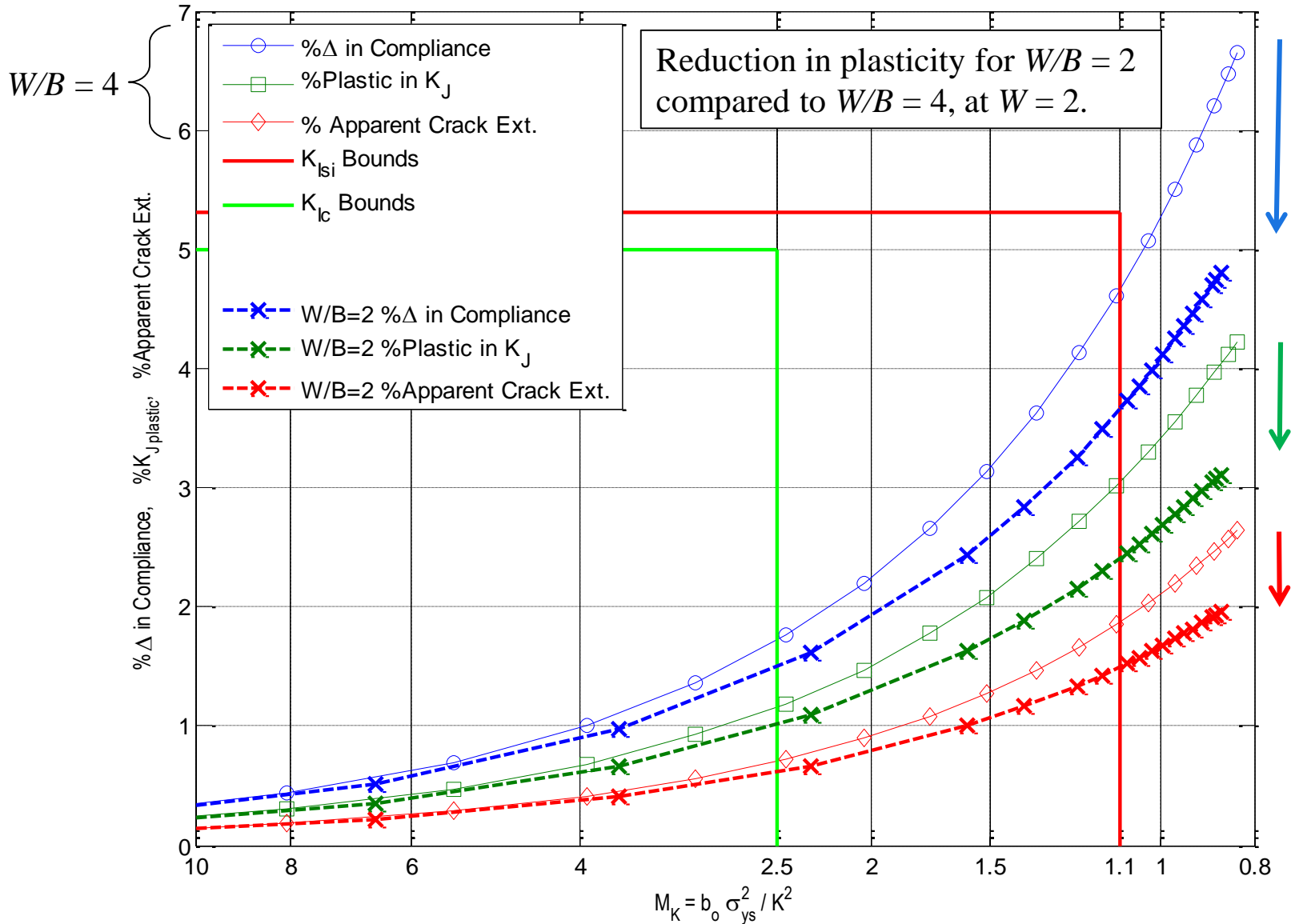



Evaluation of $W/B = 4$ versus Plane Strain

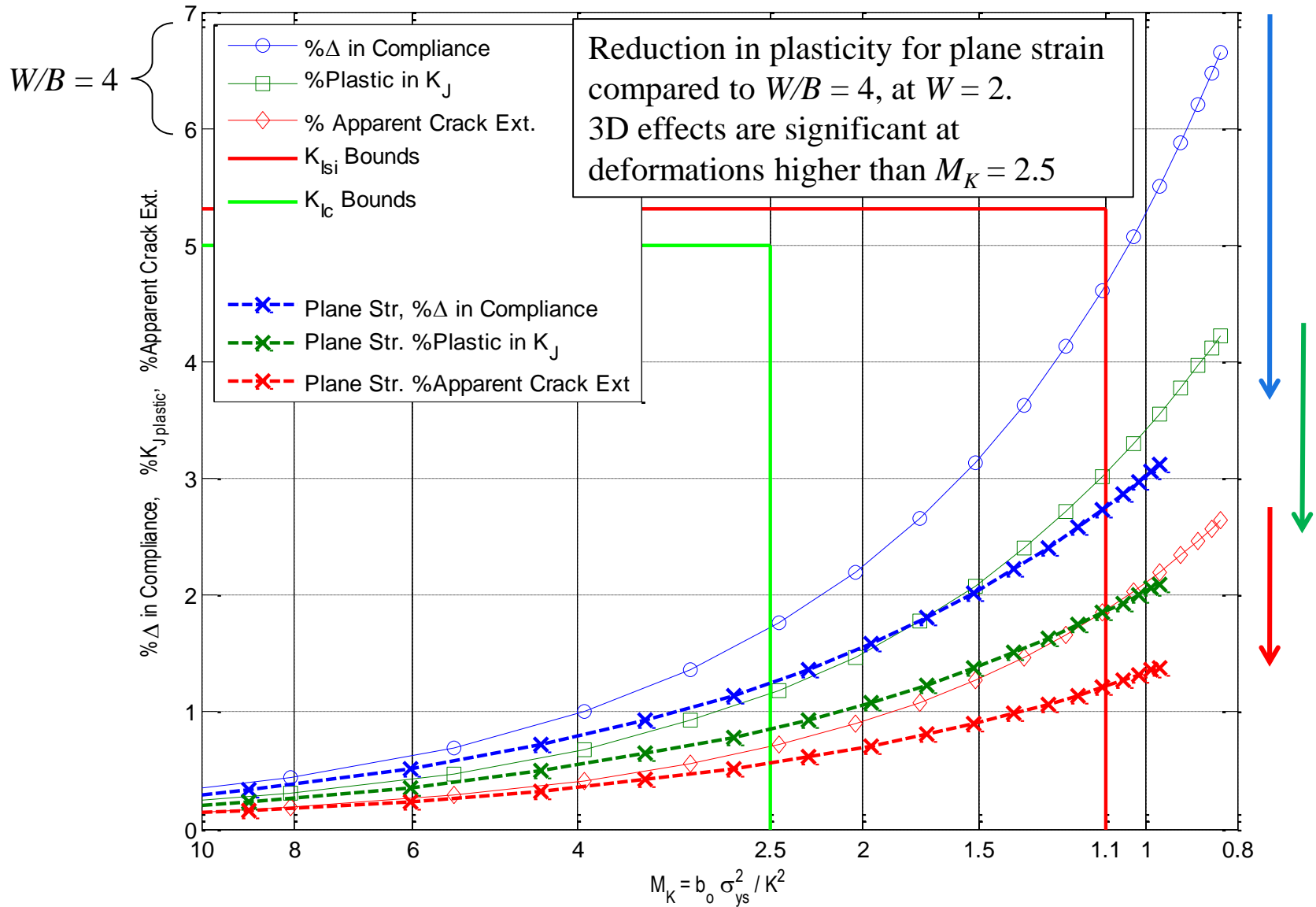



Evaluation of Side Groove Effects

Side Grooved Specimen:

To evaluate the effects of the side-grooved geometry on the force-CMOD non-linearity due to plasticity, a model with side-grooves was run using the normalized 2219-T8 material model.

Dimensions:

$$W = 2$$

$$a/W = 0.5$$

$$B = 0.5$$

$$B_N = 0.4$$

$$Be = 0.48$$

$$\text{SG angle} = 90^\circ$$

Modeled with quarter symmetry

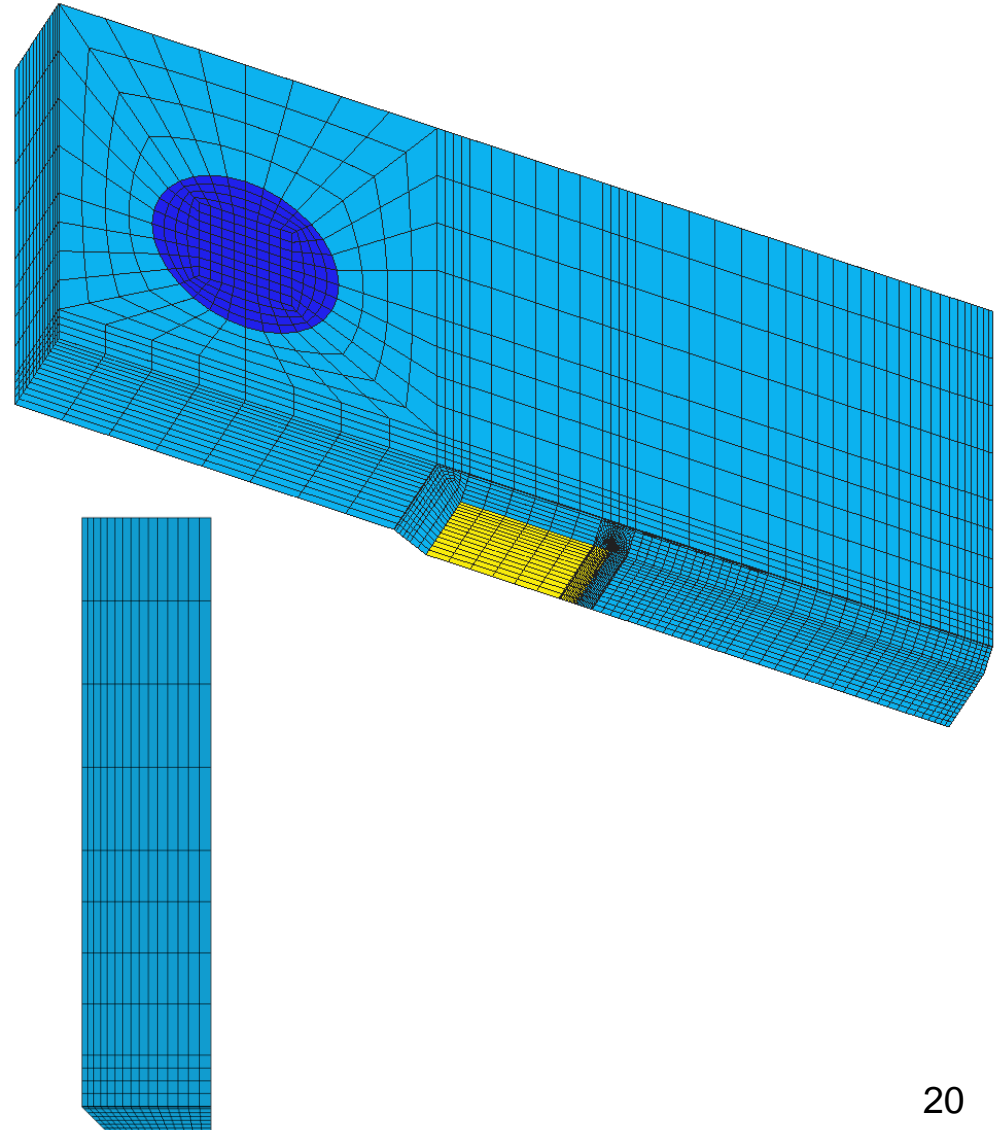



Evaluation of Side Groove Effects

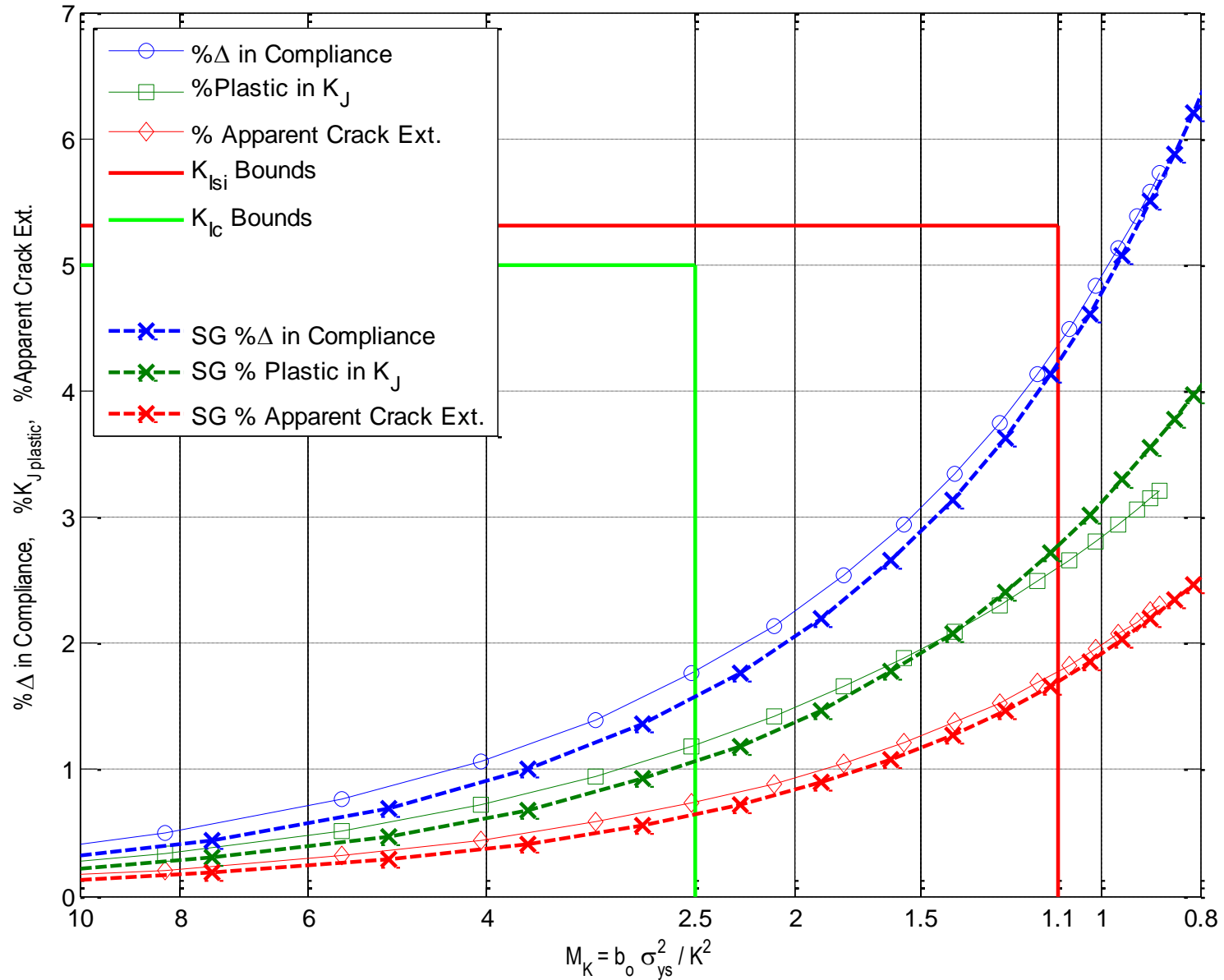

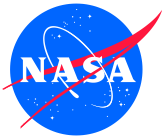

Model Scaling:

Given the objective of K_{Isi} is to reduce specimen size dependence, to evaluate the method, either models need to be run at different sizes, shown to be scalable, or evaluated by parameters that are size independent.

To evaluate scaling, consider the characteristic load expression for the C(T) specimen, reduced for $a/W=0.5$, $W/B=4$, and choosing ligament b_o as a characteristic length:

$$P_{CT} \propto \frac{Bb_o^2\sigma_o}{2W+a_o} = \frac{b_o}{2} \frac{b_o^2\sigma_o}{(2b_o)+b_o} \propto b_o^2\sigma_o$$

For two different size C(T) specimens (subscripts 1 and 2) with the same proportional geometry and material, forces may be scaled relative to their respective characteristic loads:

$$\frac{P_1}{P_{CT1}} = \frac{P_2}{P_{CT2}} \quad \text{and} \quad \frac{P_2}{P_1} = \frac{P_{CT2}}{P_{CT1}} = \frac{b_{o2}^2}{b_{o1}^2} = \phi^2 \quad \text{for} \quad \phi = \frac{b_{o2}}{b_{o1}} \quad \boxed{\therefore P_2 = \phi^2 P_1}$$

Following similar logic, $v_2 = \phi v_1$ and $K_2 = \sqrt{\phi} K_1$ and $C_2 = \frac{C_1}{\phi}$

Given this, we confirm the deformation parameter M_K is size independent:

$$M_K = \frac{b_o \sigma_{ys}^2}{K^2} \quad \text{so} \quad M_{K2} = \frac{(\phi b_{o1}) \sigma_{ys}^2}{(\sqrt{\phi} K_1)^2} = \frac{b_{o1} \sigma_{ys}^2}{K_1^2} = M_{K1}$$

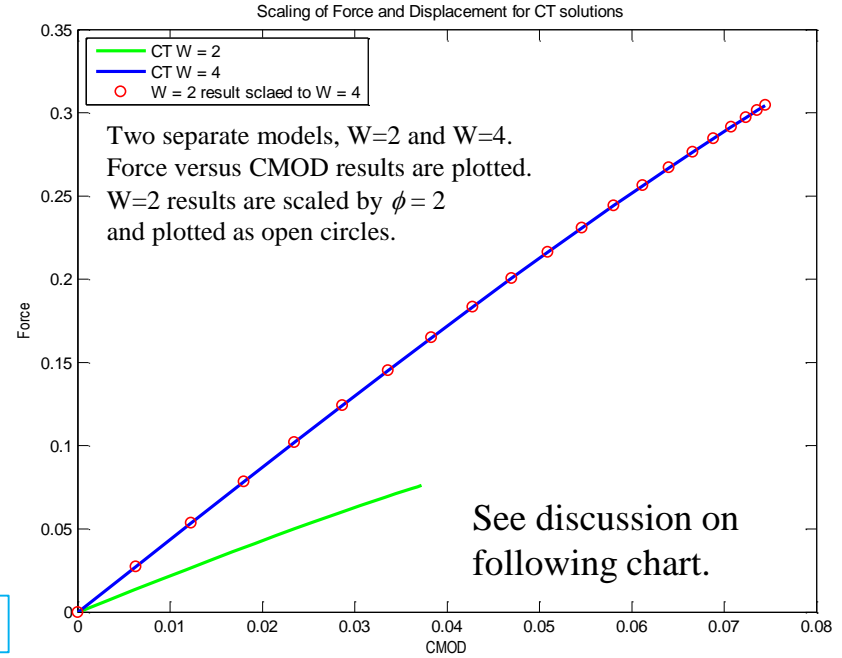

...and the % change in compliance is size independent:

$$\Delta C_{i2} = \left(\frac{\frac{C_{i1}}{\phi} - \frac{C_{o1}}{\phi}}{\frac{C_{o1}}{\phi}} \right) \times 100 = \Delta C_{i1}$$

Only one model for the C(T) geometry $W/B=4$ with $a/W=0.5$ is required to study size effects.



Executive Summary:

The proposed size-independent linear-elastic fracture toughness, K_{Isi} , for potential inclusion in ASTM E399 targets a consistent 0.5mm crack extension for all specimen sizes through an offset secant that is a function of the specimen ligament length. The K_{Isi} method also includes an increase in allowable deformation, and the removal of the P_{max}/P_Q criterion. A finite element study of the K_{Isi} test method confirms the viability of the increased deformation limit, but has also revealed a few areas of concern.

Findings:

1. The deformation limit, $b_o \geq 1.1(K_I/\sigma_{ys})^2$ maintains a K -dominant crack tip field with limited plastic contribution to the fracture energy.
2. The three dimensional effects on compliance and the shape of the force versus CMOD trace are significant compared to a plane strain assumption
3. The non-linearity in the force versus CMOD trace at deformations higher than the current limit of $2.5(K_I/\sigma_{ys})^2$ is sufficient to introduce error or even “false calls” regarding crack extension when using a constant offset secant line. This issue is more significant for specimens with $W \geq 2$ inches.
4. A non-linear plasticity correction factor in the offset secant may improve the viability of the method at deformations between $2.5(K_I/\sigma_{ys})^2$ and $1.1(K_I/\sigma_{ys})^2$.



Conclusions:

1. The deformation limit, $b_o \geq 1.1(K_I/\sigma_{ys})^2$ maintains a K -dominant crack tip field with limited plastic contribution to the fracture energy, *i.e.* the plastic portion of $K_J \approx 5\%$
2. The three dimensional effects on compliance and the shape of the force versus CMOD trace are significant compared to a plane strain assumption (see back-up charts). Plane strain is assumed in the compliance relations and offset slope percentage in E399
3. The non-linearity in the force versus CMOD trace at deformations higher than the current limit of $2.5(K_I/\sigma_{ys})^2$ is sufficient to introduce error or even “false calls” regarding crack extension when using a constant offset secant line. This issue is more significant for specimens with $W \geq 2$ inches. Side grooving the specimen does not significantly effect the non-linearity in the trace (see back-up charts).
4. The ability for the proposed K_{Isi} method to collapse size-dependence in historical data may be related to specimens having been sized close to the $2.5(K_I/\sigma_{ys})^2$ limit. The success of the method for specimens with deformations closer to $1.1(K_I/\sigma_{ys})^2$ at toughness may not be robust.
5. A non-linear plasticity correction factor in the offset secant may improve the viability of the method at deformations between $2.5(K_I/\sigma_{ys})^2$ and $1.1(K_I/\sigma_{ys})^2$.