

# EVA Swab Tool to Support Planetary Protection and Astrobiology Evaluations

Michelle A. Rucker  
NASA Johnson Space Center  
2101 Nasa Parkway  
Houston, TX 77058  
281-244-5569  
michelle.a.rucker@nasa.gov

Drew Hood  
NASA Johnson Space Center  
2101 Nasa Parkway  
Houston, TX 77058  
281-942-8858  
drew.hood@nasa.gov

Mary Walker  
NASA Johnson Space Center  
2101 Nasa Parkway  
Houston, TX 77058  
281-244-2772  
mary.walker@nasa.gov

Dr. Kasthuri J. Venkateswaran  
NASA Jet Propulsion Laboratory  
4800 Oak Grove Drive  
Pasadena, CA 91109  
818-393-1481  
kasthuri.j.venkateswaran@jpl.nasa.gov

Dr. Andrew C. Schuerger  
University of Florida  
505 Odyssey Way, Exploration Park  
Merritt Island, FL 32953  
321-261-3774  
schuerg@ufl.edu

**Abstract**—When we send humans to search for life on other planets, we'll need to know what we brought with us versus what may already be there. To ensure our crewed systems meet planetary protection requirements—and to protect our science from human contamination—we'll need to assess whether microorganisms may be leaking or venting from our spacecraft. Microbial sample collection *outside* of a pressurized spacecraft is complicated by temperature extremes, low pressures that preclude the use of laboratory standard (wetted) swabs, and operation either in bulky spacesuits or with robotic assistance. A team at the National Aeronautics and Space Administration (NASA) recently developed a swab kit for use in collecting microbial samples from the external surfaces of crewed spacecraft, including spacesuits. The Extravehicular Activity (EVA) Swab Kit consists of a single swab tool handle and an eight-canister sample caddy. The design team minimized development cost by re-purposing a heritage Space Shuttle tile repair handle that was designed to quickly snap into different tool attachments by engaging a mating device in each end effector. This allowed the tool handle to snap onto a fresh swab end effector much like popular shaving razor handles can snap onto a disposable blade cartridge. To disengage the handle from a swab, the user performs two independent functions, which can be done with a single hand. This dual operation mitigates the risk that a swab will be inadvertently released and lost in microgravity. Each swab end effector is fitted with commercially available foam swab tips, vendor-certified to be sterile for Deoxyribonucleic Acid (DNA). A microbial filter installed in the bottom of each sample container allows the container to outgas and re-pressurize without introducing microbial contaminants to internal void spaces. Extensive ground testing, post-test handling, and sample analysis confirmed the design is able to maintain sterile conditions as the canister moves between various pressure environments. To further minimize cost, the design team acquired extensive ground test experience in a relevant flight environment by piggy-backing onto suited crew training runs. These training runs allowed the project to validate tool interfaces with pressurized EVA gloves and collect user feedback on the tool design and function, as well as characterize baseline microbial data for different types of spacesuits. In general, test subjects found the EVA Swab Kit relatively straightforward to operate, but identified a number of design improvements that will be incorporated into the final design. Although originally intended

to help characterize human forward contaminants, this tool has other potential applications, such as for collecting and preserving space-exposed materials to support astrobiology experiments.

## TABLE OF CONTENTS

1. INTRODUCTION .....	1
2. PROTOTYPE SWAB TOOL DESIGN .....	2
3. FORM, FIT AND FUNCTION TESTING .....	3
4. SPACESUIT MICROBIAL EVALUATIONS.....	4
5. POTENTIAL DESIGN IMPROVEMENTS.....	5
6. FORWARD WORK.....	6
7. EVA SWAB KIT APPLICABILITY.....	6
8. CONCLUSIONS .....	6
ACKNOWLEDGEMENTS .....	7
REFERENCES .....	7
BIOGRAPHY .....	7

## 1. INTRODUCTION

### *Background*

Wherever humans travel, we will inevitably carry along the organisms that live in and on us. Unlike the robotic Mars rovers that were cleaned once and sent on their way, human explorers will be a constantly regenerating contaminant source that pose challenges as we search for life at new destinations. If extraterrestrial life is identified, it will be equally important to ensure that it does not inadvertently hitch a ride back to Earth when our explorers return. To verify both forward and reverse contamination controls, robust microbial sampling methods and collection tools will be needed.

### *Microbial Sampling*

On Earth, microbial sampling is relatively simple: a

researcher dons sterile gloves and swipes the surface of interest with a sterile, soft-tipped swab (Figure 1), often wetted with a sterile solution to improve sample collection. The swab is placed into a sealed, sterile container and either transported to an analysis laboratory or stored in a freezer for later analysis.

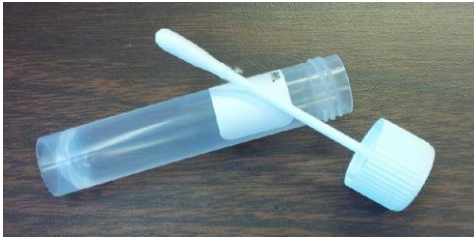

**Figure 1. Typical laboratory swab**

Unfortunately, sampling surfaces *outside* of a spacecraft is not as simple. First, the swab must be designed for use with large, bulky Extravehicular Activity (EVA) gloves or interface with robotic manipulators. In microgravity environments, the swab must be tethered to prevent inadvertent loss of swab materials. The construction must be compatible with spacecraft cabin flammability and toxicity requirements and EVA temperatures and vacuum. Both the swab and container must remain sterile when transiting from a spacecraft pressure cabin to vacuum and back again.

There is currently no American EVA swab tool approved for use outside of a spacecraft. Russia’s Central Engineering Scientific Research Institute (TSNIIMASH) and the Institute of Biomedical Problems (IBMP) have developed the “Test” swab kit to evaluate exterior surfaces on International Space Station (ISS) Russian elements, but this kit can only obtain two samples, and there is limited published information on sterilization levels or methods.

## 2. PROTOTYPE SWAB TOOL DESIGN

A team of National Aeronautics and Space Administration (NASA) engineers and scientists developed a prototype EVA microbial sampling kit that pairs a single tool handle with a bank of sterile swab tips, allowing a user to collect up to eight microbial samples for each kit taken on an EVA excursion.

### *Tool Handle*

The tool handle (Figure 2) is a heritage Space Shuttle tile repair device designed to quickly snap into different attachments by means of a spring-loaded mechanism that engages a mating device in each end effector (Figure 3). This allows the handle to snap onto a fresh swab end effector, much like popular shaving razor handles can snap onto a disposable blade cartridge. The handle features a large loop on one end for attachment to an EVA tether. To disengage the handle from a tip attachment, the operator slides a spring-loaded cover towards the tool tip, and squeezes a pair of exposed paddles (Figure 2, right). This dual-action operation, which can easily be performed with one hand while wearing

bulky EVA gloves, mitigates the risk that a tool tip will be inadvertently released and lost in microgravity.



**Figure 2. EVA Swab Tool Handle Operation**

### *Swab End Effector Assemblies*

Swab End Effector Assemblies (Figure 3) consist of an anodized aluminum holder designed to interface with the tool handle and a large, paddle-shaped macrofoam swab tip held in place with two corrosion-resistant steel set screws. A mating device on each swab end effector engages the spring-loaded mechanism in the tool handle. Macrofoam swabs are medical grade, commercially available from Puritan Medical Products Company, part number 25-1805 IPF RND. The swab tips are vendor-certified to be sterile for Deoxyribonucleic Acid (DNA) and measure approximately 2.3 centimeters (cm) (0.906 inch, in) diameter. A piston O-ring seal near the base prevents contaminants from entering the top of the sample container while the end effector is in place.



**Figure 3. Swab Tool End Effector Assembly**

### *Sample Canisters*

Swab end effectors are housed in individual sterile containers, as shown in cross-section in Figure 4. A pair of ball detents hold the swab tip in the container, but allows the tip to be removed with an upward pull of approximately 22 Newton (N) (5 pounds-force,  $lb_f$ ) on the tool handle. In the bottom of each container is a 0.22 micron pore microbial filter assembly that allows the container to equalize atmospheric pressure, but prevents contaminants from rushing into the container when passing from the EVA environment into a pressurized cabin. The commercially available filter assembly contains a Polytetrafluoroethylene (PTFE) filter element.

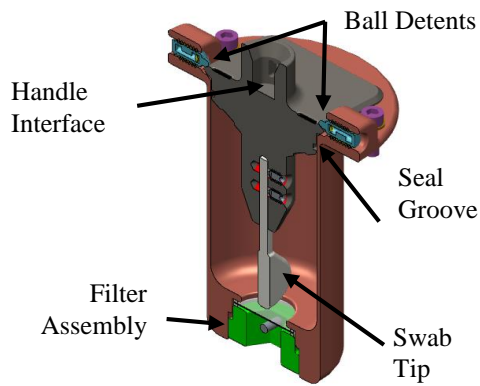

**Figure 4. Sample Canister/End Effector Assembly**

*Sample Caddy*

The prototype sample caddy (Figure 5) was fabricated of ULTEM® 1000 polyetherimide, and sized to accommodate two sample canisters on one side (not shown), and six on the other. An anodized aluminum carrying handle was mounted on one end.

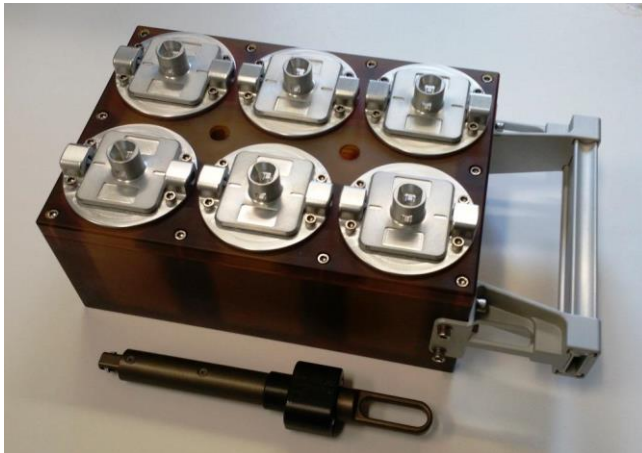

**Figure 5. Sample Caddy and Tool Handle**

*Swab Kit Sterilization*

Each sample canister (assembled with filter and ball plungers) was placed into a separate autoclave bag. Each swab end effector assembly (including set screws and O-ring, *but without swab tip*) was placed into a separate autoclave bag. Bagged assemblies were then placed into a Steris LV 250 Laboratory Steam Sterilizer and sterilized using a gravity cycle of 45 minutes at 121 degrees Celsius (°C) (250 degrees Fahrenheit, °F) and 103.4 kilopascals (kPa) (15 pounds per square inch, psi). Neither the sample caddy box nor the tool handle were autoclaved, but both were verified Visibly Clean (VC) [1].

Following autoclaving, bagged assemblies were transferred to an ISO Class 5 clean bench for swab tip installation. Technicians wore latex gloves, and both the gloves and assembly tools (Allen wrench, scissors, and forceps) were sprayed with ethanol surface disinfectant. All parts were handled either with forceps or the autoclave bags, with no

contact between the gloves and tool areas that must remain sterile. With the commercial swab inside its sterile packaging, the swab stem was cut to approximately 6.0 cm (2.4 in) length using sterilized scissors, making sure the swab head remained inside its packaging until the final assembly step. The cut end of the swab was then inserted into the end effector slot and set screws were tightened to hold the swab in place, then the end effector was placed into a sterile container assembly and labeled with a unique sample identifier. Each container/end effector assembly was then mounted into the tool caddy, which was placed into controlled storage until test.

**3. FORM, FIT AND FUNCTION TESTING**

*Swab Tip Environmental Testing*

To verify the commercial swab tip could survive a space environment without generating hazardous debris, a series of environmental tests were conducted. The macrofoam paddle swab, along with two other types of foam swabs, were placed into a thermal chamber, at ambient pressure, and reduced from room temperature to -73.3°C (-100°F), stopping periodically for pull and bend evaluations. At -40°C (-40°F) all swab tips began to stiffen, and at -51.1°C (-60°F) swab stems were noticeably harder to bend, though not brittle. At -62.2 °C (-80°F) the paddle-type swab tip experienced very minor deformation while the other two swab types exhibited considerably more deformation. After reaching -73.3°C (-100°F), the chamber temperature was reversed, increasing to 37.8°C (100°F) while stopping periodically for bend and pull tests. Swab tip deformation decreased at -6.7°C (20°F), and swab stems returned to room temperature flexibility at about 4.4.°C (40°F). Testing indicated that the swabs would maintain integrity under expected loading, even at temperature extremes.

*Swab Tip Effectiveness*

Laboratory tests at NASA’s Jet Propulsion Laboratory (JPL) demonstrated that the dry swab tip was at least as effective at collecting microorganisms as a standard wetted swab. Results were replicated at NASA’s Johnson Space Center (JSC). It is assumed that the oversized swab paddle, combined with the porous macrofoam material, is able to compensate for the dry swab. Because the macrofoam acts like a sponge, the main challenge in using this type of swab is getting the foam to release the collected microorganisms for analysis.

*Functional Evaluations*

To assess crew interface, a series of reduced pressure glovebox tests was conducted with different test subjects wearing flight-like EVA gloves. External pressure was reduced to 29.65 kPa (4.3 psi) differential across the gloves, then evaluations were repeated at 55.19 kPa (8 psi) differential pressure across the gloves. No issues were identified in tool handling or operation.

*Variable Pressure Evaluations*

The test team subjected the prototype swab kit to both elevated and variable pressure conditions by piggy-backing onto a planned NASA analog mission event. The swab kit was used to collect microbial samples from surfaces inside an analog mission habitat at 243 kPa (35.3 psi), then the kit was transferred back to ambient conditions before being air freighted cross-country to JPL's analysis laboratory. Post-mission microbial analysis of samples, as well as control swab/container assemblies, verified that the design could withstand extensive handling and operational pressure changes without contaminating the contents. Microbial samples collected during the analog mission served double-duty by also supporting an independent JPL research effort to characterize closed environments.

#### 4. SPACESUIT MICROBIAL EVALUATIONS

A wealth of swab kit operational experience was collected by piggy-backing onto planned spacesuit evaluations at JSC. Microbial analysis of controls and swabs used in these tests not only confirmed that the kit was able to collect and preserve microorganisms, but also provided baseline spacesuit microbial data under both laboratory and simulated space environmental conditions.

To date, the prototype EVA swab kit has been operated by 17 different test subjects, during 13 separate test events involving four types of spacesuits. All but one of these tests was conducted with differential pressure across the space suits (higher suit internal pressure); three data sets were collected under suit external vacuum conditions. Test subjects included volunteers as well as both American and international partner astronauts training for International Space Station (ISS) missions. Suits used during these evaluations included the Mark III advanced suit (Figure 6), the Extravehicular Mobility Unit (EMU) design currently used on board ISS (Figure 7), the Modified Advanced Crew Escape System (MACES), and the Orion Crew Survival System (OCSS, Figure 8).

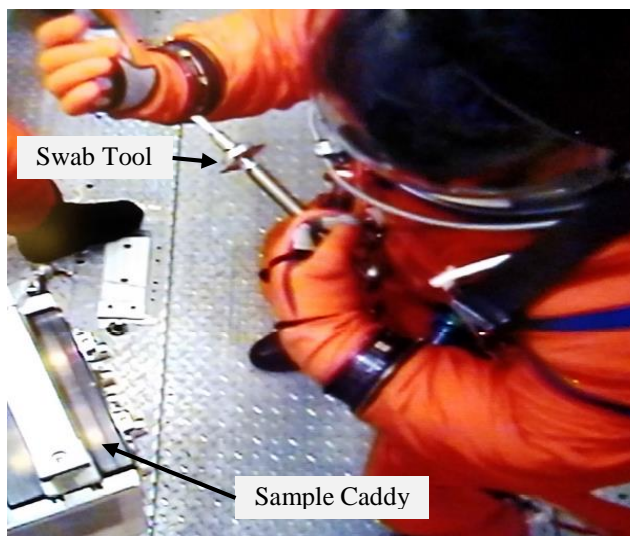

**Figure 6. Mark III Spacesuit Swab Evaluation**

In each of these evaluations, suited test subjects were asked to sample six surfaces plus take one environmental control sample (remove the swab from its container for about five seconds, and replace without contacting any surface). At least one swab remained inside its canister as a control during each test run. Swab evaluations focused on suit wrist joints, which were of interest as a potential microbial leak path. Collecting a full prototype kit of samples (six surfaces, one environmental control, and one unused control) was typically accomplished in 20 minutes or less.



**Figure 7. EMU Wrist Joint Sampling**



**Figure 8. OCSS Wrist Joint Sampling at Vacuum**

A test engineer manually held the sample caddy during ambient external pressure tests, but the caddy was wall-mounted during external vacuum tests (as shown in Figure 8).

Mark III and EMU-suited test subjects swabbed their own wrist joints. Having multiple, concurrent suited subjects available during OCSS/MACES test opportunities allowed test subjects to swab each other's suit joints. Operators reported a better experience with the Mark III and EMU gloves than with the MACES or OCSS gloves, likely due to differences in glove design. In general, all test subjects were able to attach and detach swab end effectors from the tool handle with little difficulty and tool control was very good,

with few instances of inadvertent contact with unintended surfaces. Operational efficiency improved with practice.

Many operators chose to use the tool handle untethered, but several test subjects attached a retractable tether between the tool handle's end loop and either a Mini Work Station (MWS, as shown in Figure 9), or to the sample caddy itself. The tether did not appear to impede swab tool operation.

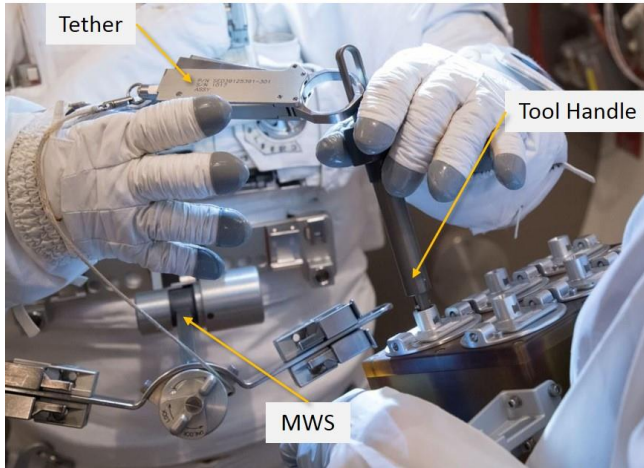

**Figure 9. Tethered Swab Tool Use**

Only one serious technical issue was encountered: on two occasions, the piston O-ring seal at the base of a swab end effector rolled out of the seal groove while inserting or removing the end effector from its sample container. Aside from compromising the sterility of that particular sample assembly, a loose O-ring poses a safety concern in microgravity and necessitates a seal redesign.

Although the ball-detents were generally effective at holding swab end effectors in place in their sample containers, many operators found they had better tool handle control by rocking the end effector to release one of the two ball detents at a time. Variability was noted in end effector release force, likely due to ball detent position (as dictated by a positioning set screw on each detent). Several test subjects noted that a twist-to-release motion might offer better tool control than the pull-to-release design.

## 5. POTENTIAL DESIGN IMPROVEMENTS

### *End Effector-to-Canister Seal Redesign*

Improvements under consideration include a retaining ring to prevent the O-ring from rolling out of its piston seal groove, or a different seal profile to mitigate rolling. Alternatively, the piston seal arrangement could be replaced altogether with a flange seal, though the ball detents would have to be altered or replaced to ensure a compression force between each end effector and the top of its sample canister.

### *End Effector Locking Device*

The swab end effector-to-sample container interface could be modified from a piston/cylinder pull-to-release design to a twist-to-release arrangement with a quarter-turn thread or even a breech-lock thread to hold the end effector in the sample container. In addition to providing smoother tool handle control, this type of redesign would also make a compression seal more feasible.

### *Swab Re-Use Prevention*

Although operators have not inadvertently re-used a given swab during these evaluations, the design team was concerned that there was no visible distinction between sterile and used swabs, leading to the potential for human error. One idea discussed was a ratcheting device to lock used swabs into their sample containers, preventing inadvertent re-use. In such a scheme, an operator might line up indexing marks pre- and post-use. Once re-inserted in the "used" orientation, a ratchet tooth would lock the swab into the container, while the index marks would provide a visual indication of which swabs had been used and which were still sterile. If combined with the quarter turn, twist-to-release end effector redesign noted above, additional indexing marks would indicate the direction of turn as shown in Figure 10.

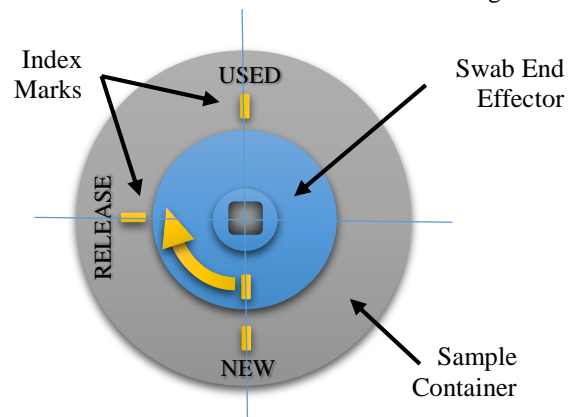

**Figure 10. Notional End Effector Clocking Redesign**

### *Sample Caddy Handle*

In several test runs it was noted that the operator wanted to push one hand against the sample caddy face to provide a reaction force when removing swabs with the other hand (Figure 11). This placed EVA gloves relatively close to an open sample container, posing a potential contamination issue.

Operators did not try to react against the caddy during vacuum test runs when the caddy was rigidly mounted to structure, indicating that a rigid caddy mount would mitigate this problem. In microgravity, both the operator and the caddy would have to be rigidly mounted. Alternatively, a second handle or tab could be added to the caddy for an operator to react against, though this would add mass. If the pull-to-release end effector design is replaced with a twist-to-release concept as described above, the operator may be inclined to react against the sides of the caddy, rather than the

sample container face, which could also mitigate potential contamination concerns.



**Figure 11. Caddy Reaction Force**

## 6. FORWARD WORK

### *Spacesuit Microbial Analysis*

Spacesuit samples collected during EVA swab kit evaluations (as well as pre- and post-test baseline samples of the test chambers), are currently being analyzed. Microorganisms that were found to be viable after several hours of vacuum exposure during these tests will be of particular interest to researchers. Culture analyses and microorganism Deoxyribonucleic Acid (DNA) sequencing results will be provided to the science community to support planetary protection protocol development for future human missions to Mars. No attempt was made to change normal suit cleaning or handling procedures, so this data represents a baseline against which improved suit design, cleaning, or handling protocols may be assessed.

### *EVA Swab Kit Flight Design*

Design improvements as noted above will be incorporated into the prototype kit. As suited test opportunities arise, these design improvements will be evaluated, and data used to support flight hardware certification. Although the swab kit has been evaluated at both flight temperatures and vacuum conditions, it remains forward work to evaluate the kit under the combination of temperature and pressure extremes.

### *Potential ISS Use*

Once design improvements are incorporated, the EVA swab kit can be certified for ISS use. Armed with an EVA-compatible surface sampling tool and insights about EVA suit microbial characterization, researchers will be well-positioned to collect micro-organisms found *outside* a crewed spacecraft. Taking the same approach used during ground testing, the EVA swab kit could be an add-on to planned EVA excursions, on a non-interference basis, to collect samples at relatively little cost. Sample containers could either be returned to Earth for analysis, or paired with the Biomolecule Sequencer [2] for on-board swab analysis.

There are currently more than a dozen Environmental Control and Life Support System external vents on the ISS. Some vent waste products while others are intended to equalize cabin pressure. If an EVA opportunity allows, microbial samples from any of these external vents would provide baseline crewed spacecraft data, against which future mitigation strategies—such as vent port filters—may be assessed. Samples collected at various distances from particular vent ports or airlock hatches could help characterize microbial dispersion patterns. Understanding the viability of micro-organisms at various distances from spacecraft openings will aid in understanding the effects of spacecraft-induced environments and inform future mitigation strategies or design concepts.

## 7. EVA SWAB KIT APPLICABILITY

### *Astrobiology Research*

Although intended as a tool to support human forward contamination planetary protection protocols, other potential EVA Swab Kit uses have been identified. For example, Russian research has identified plankton on Russian ISS segment external surfaces [3], but to date no samples have been collected on American segment external surfaces for comparison. Several private firms have also expressed interest in partnering with NASA to search for extremophile bacteria on external spacecraft surfaces using the EVA swab kit.

If paired with a sterile robotic manipulator, the EVA swab kit could be used to collect and preserve space-exposed materials to support astrobiology experiments on uncrewed science missions, or on crew-controlled telerobotic surface rovers.

### *Micrometeoroid/Orbital Debris Evaluations*

By replacing the foam swab tip with a sticky-tape type of end effector, this kit could also be used to collect residue from micrometeoroid or orbital debris impacts for analysis, as was used during the shuttle tile repair era. This would be particularly helpful in performing damage assessments of hardware that cannot be brought inside a spacecraft or returned to Earth for analysis.

## 8. CONCLUSIONS

Laboratory and vacuum chamber testing validated NASA's EVA swab kit interface with pressurized EVA suits, and provided user feedback on tool design and function. In general, test subjects found the tool relatively straightforward to operate, though a number of design improvements were identified and will be incorporated into a flight design.

The project team minimized development costs by repurposing retired Space Shuttle Program hardware, and by piggy-backing onto suited flight crew training exercises. Microbial data collected during the engineering evaluations

will populate a baseline database for use in developing planetary protection protocols for human missions to Mars.

In addition to human forward contamination characterization, the EVA swab kit has potential applicability to astrobiology research and micrometeoroid/orbital debris failure investigations. A number of interesting ISS applications have been identified and will be pursued, pending funding.

### ACKNOWLEDGEMENTS

The authors thank NASA's Douglas Terrier and the Science and Technology Mission Directorate for funding this project, and a cross-organizational test and analysis team, including Mary Sue Bell, Alex Horvath, Justin Connolly, Bekki Bruce, Christian Castro, Dr. Aaron Regberg, Dr. Ganesh Babu Malli Mohan, and Dr. Camilla Urbaniak.

### REFERENCES

- [1] JPR 5322.1, *JSC Contamination Control Requirements*, National Aeronautics and Space Administration, Houston, TX.
- [2] John, K.K., et al., *The Biomolecule Sequence Project: Nanopore Sequencing as a Dual-Use Tool for Crew Health and Astrobiology Investigations*, 47<sup>th</sup> Lunar and Planetary Science Conference, The Woodlands (2016).
- [3] TASS Russian News Agency, *Traces of Barents Sea plankton, bacteria from Madagascar found on ISS surface*, May 30, 2017. <http://tass.com/science/948405>. Referenced July 15, 2017

### BIOGRAPHY



**Michelle Rucker** received a B.S. (1984) and M.A. (1986) in Mechanical Engineering from Rice University and has been with NASA for 31 years. She currently serves in the Exploration Integration and Science Directorate at the Johnson Space Center, developing system and mission concepts for a human Mars exploration. She began her NASA career as a test engineer at the White Sands Test Facility before moving onto roles as a deputy subsystem manager for the International Space Station, EVA and Spacesuit Systems Deputy Branch Chief, and Altair Lunar Lander Test and Verification Lead.



**Drew Hood** received a B.A. in Mechanical Engineering from Purdue University in 2012 and began his NASA career as an intern in 2009. He now works for the Engineering Directorate at Johnson Space Center developing EVA tools and equipment. His current work includes hardware development for the International Space Station as well as Advanced EVA Technology for future deep space missions.



**Mary Walker** received a B.S. in Mechanical Engineering from the University of Kentucky in 2015 and began her NASA career as an intern in 2013. She now works for the Engineering Directorate at Johnson Space Center developing EVA tools and equipment. Her current work includes hardware for the International Space Station as well as Advanced EVA Technology for future deep space missions.



**Dr. Kasthuri Venkateswaran (Venkat)** received a PhD in Marine Microbiology from Annamalai University, India in 1981 and conferred a Doctorate in Agriculture from Hiroshima University, Japan in 1990. At present, Venkat is the Senior Research Scientist at NASA – Jet Propulsion Laboratory and supports Biotechnology and Planetary Protection Group. He has 40+ years of research in the field of marine, food, and environmental microbiology. He has applied his research in molecular microbial analysis to better understand the ecological aspects of microorganisms.



**Dr. Andrew C. Schuerger** received his BS (1979) and MS (1981) degrees from the University of Arizona and his Ph.D. (1991) from the University of Florida studying microbiology and plant pathology. Dr. Schuerger worked 18 years (1982-2000) at The Land at Epcot Center, Florida (a hydroponic research and education facility) developing disease management programs for viral, bacterial, fungal, and nematode diseases of vegetable and agronomic crops. His research interests have closely paralleled NASA's Bioregenerative Life Support Systems (BLSS) and Astrobiology programs. In 2003 Dr. Schuerger joined the Department of Plant Pathology at the University of Florida as a Research Assistant Professor to continue his Mars astrobiology and ALS research activities. His current research efforts include (1) studying the survival, growth, and adaptation of terrestrial microorganisms under simulated Martian conditions; (2) characterizing the UV-photolytic generation and destruction processes of

*methane on Mars, a potential biosignature molecule in the Martian atmosphere; and (3) characterizing the development of plant pathogens in BLSS habitats.*