

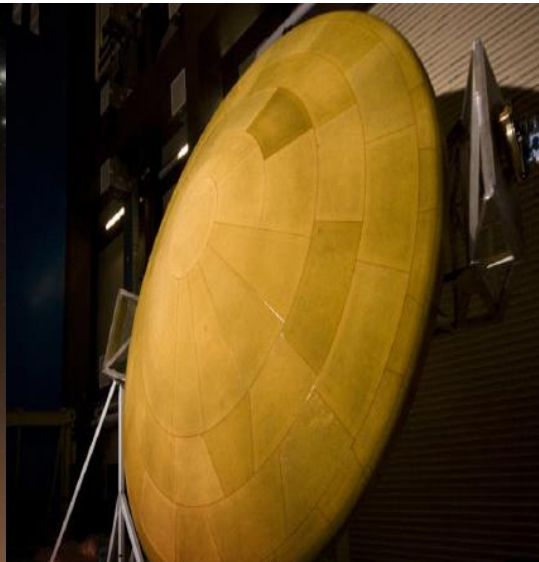

Mars Science Laboratory Heatshield Flight Data and Analysis

Milad Mahzari, Todd White
NASA Ames Research Center

Hypersonic Vehicle Flight Prediction Workshop
June 21, 2017

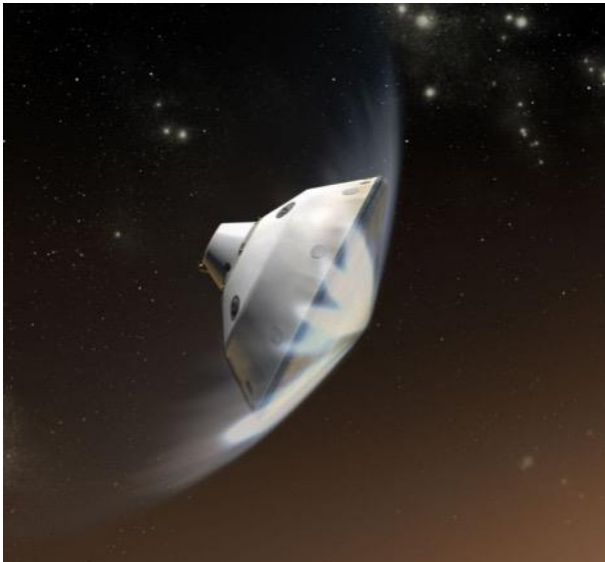

Outline



- MSL Entry Descent and Landing Overview
- Heatshield Instrumentation (MEDLI)
- Heatshield Flight Data
- Turbulent Transition
- Comparison to Model Predictions
- Surface Heating Reconstruction
- Mars2020 Heatshield Instrumentation (MEDLI2)

Mars Science Laboratory Entry Vehicle



- Successfully landed the Curiosity rover on the Martian surface on August 5th, 2012
- The entry vehicle was a 70-degree 4.5-m diameter spherecone
 - First lifting entry at Mars, nominal hypersonic angle of attack of 16 degrees
- The forebody heatshield was made of Phenolic Impregnated Carbon Ablator (PICA) tiles (
 - Same material was used on NASA Stardust mission and SpaceX Dragon
- Backshell was shielded using SLA-561V and Acusil-II

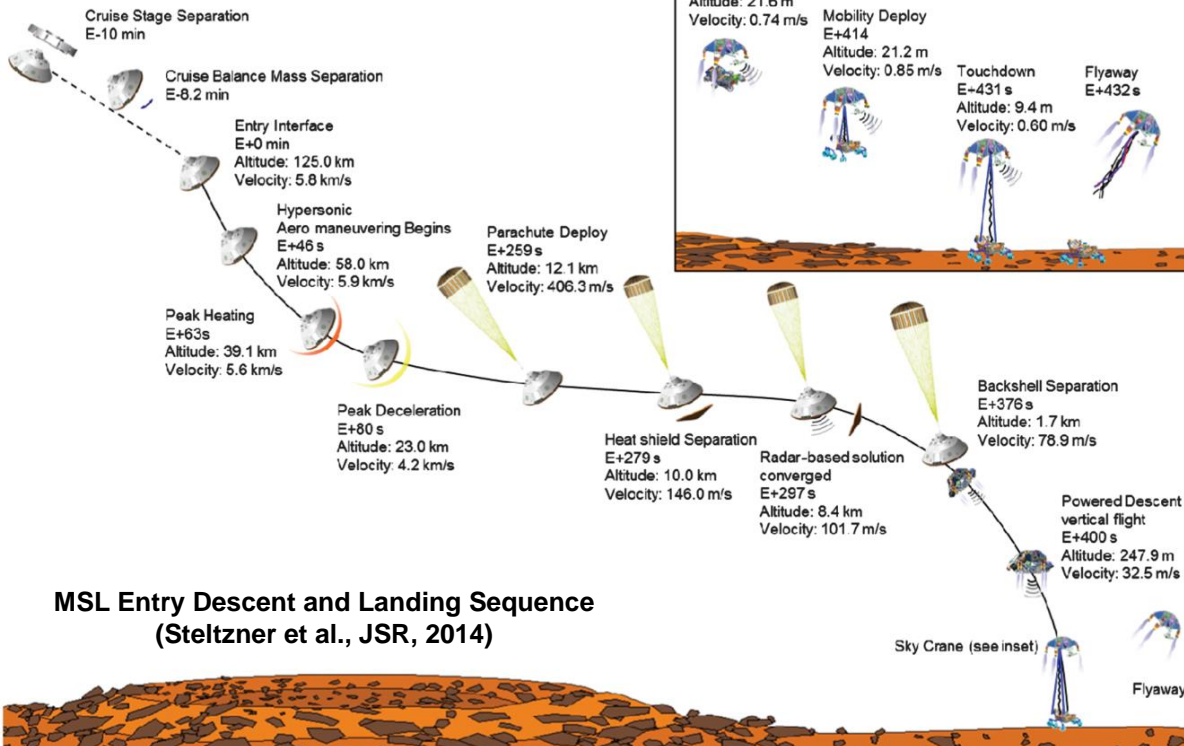
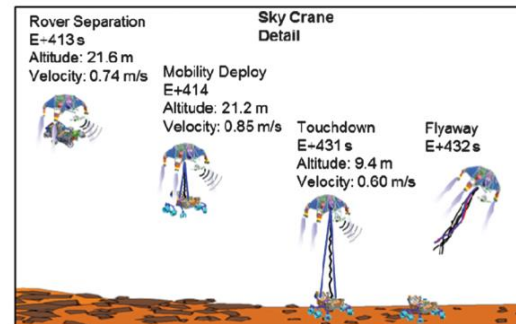
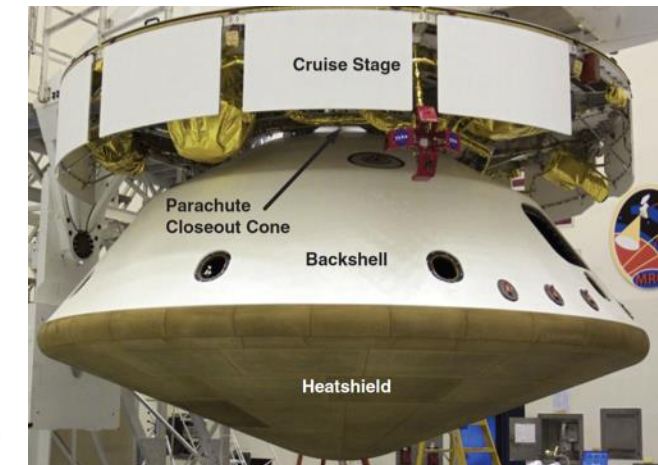
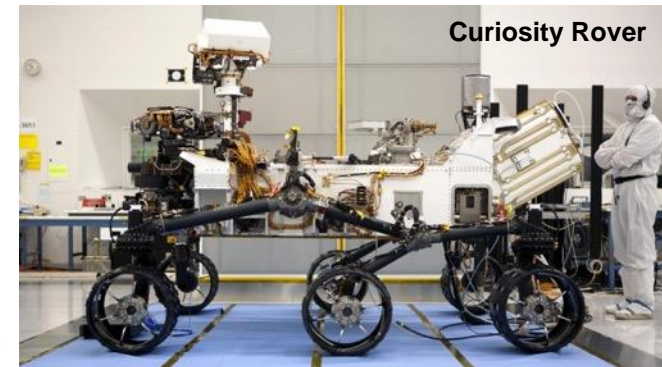

MSL Entry Descent and Landing Sequence
(Steltzner et al., JSR, 2014)

MSL Heatshield Design (1)



- Observed failures in shear testing of SLA-561V led to a late switch of TPS material to PICA
 - Heatshield thickness was set to 1.25" based on max allowable mass
 - Design focused on showing that PICA can survive heating environments and as-built thickness was sufficient
- Significant effort was made to model aerothermal environments and validate CFD tools using ground experimental data
 - AEDC Tunnel 9, Langley 20 in. Mach 6, CalTech T5, CUBRC LENS I
 - Generally good agreement between model predictions and ground data
 - Ground data showed higher heating in stagnation region
- Design environments used conservative assumptions
 - Fully turbulent, supercatalytic (full recombination to freestream composition)
 - Include heating augmentation due to distributed roughness
 - Include margins to account for biases/uncertainties

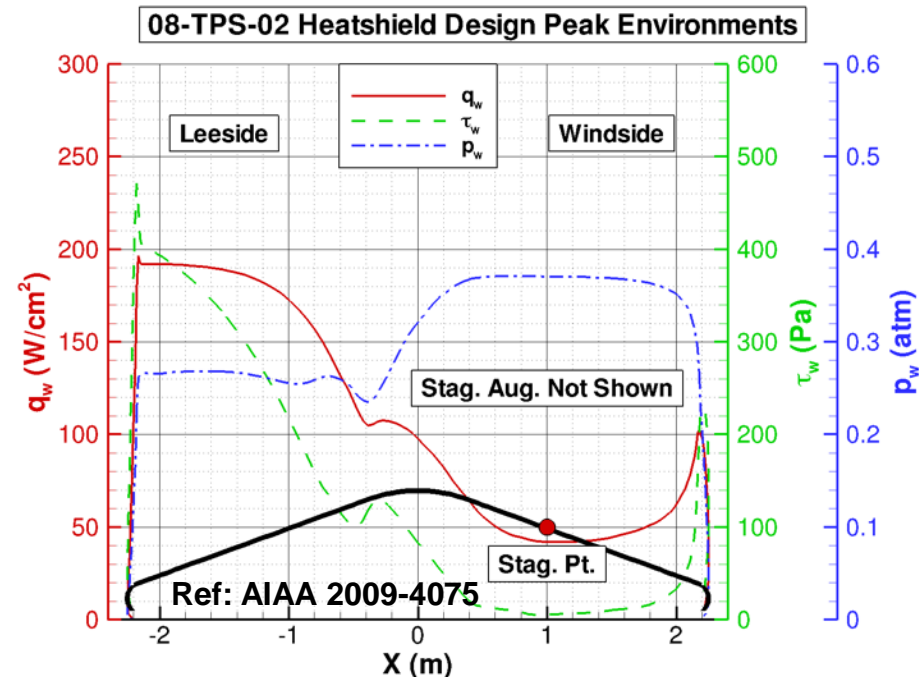
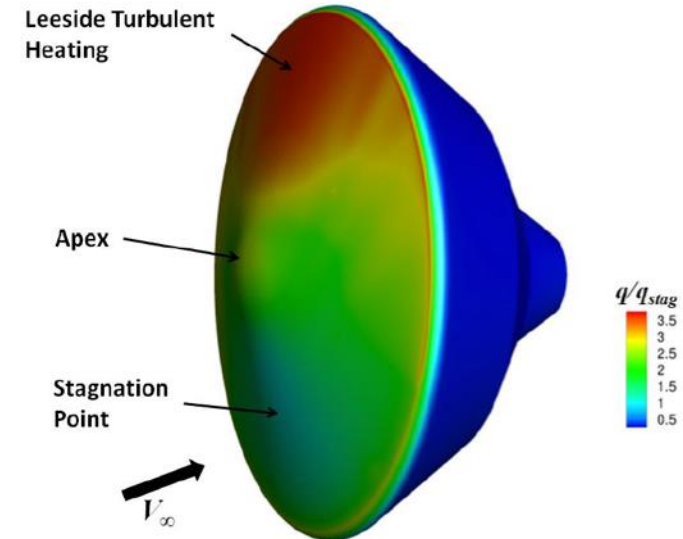

MSL Heatshield Design (2)



- MSL heatshield was made of PICA tiles with RTV gap fillers
- Orion TPS Advanced Development Project and MSL program conducted many arcjet tests to qualify PICA and gap filler design and to develop PICA response model
- Observed RTV fencing at low heating conditions
 - Dependent on heat flux, exposure time and gap filler direction with respect to flow
- Observed augmented PICA recession in ground shear tests
 - Compared to recession predicted by equilibrium gas-surface chemistry models
 - Led to inclusion of a recession lien in heatshield sizing
 - Later suspected to be due to test coupon design



Augmented PICA Recession in Shear Testing

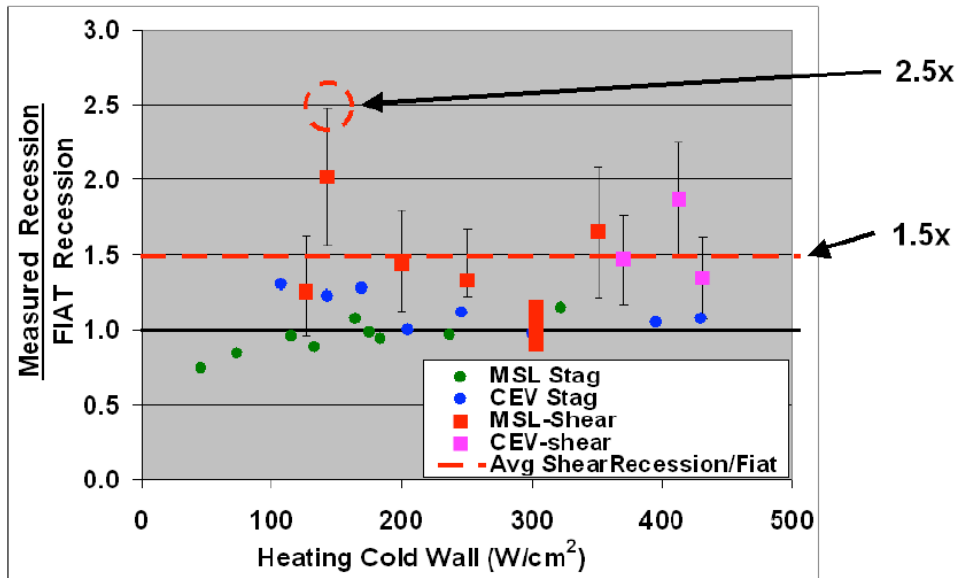

Stagnation and Shear Testing of RTV Gap Fillers

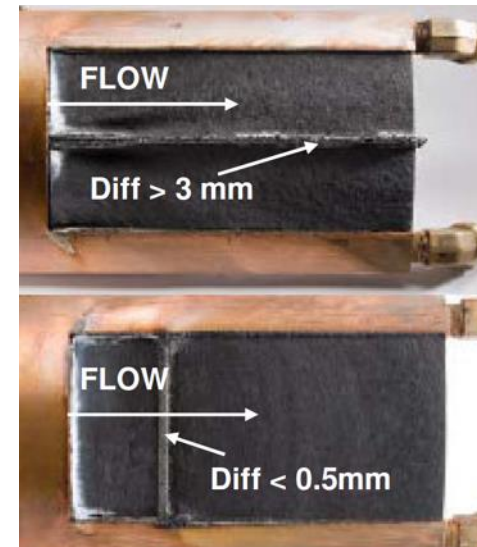

Ref: AIAA 2009-4229

Heatshield Instrumentation



- The MSL Entry, Descent and Landing (EDL) Instrumentation Suite (MEDLI), located on the heatshield:
 - MEADS (Mars Entry Atmospheric Data System), Pressure ports and transducers
 - **MISP (MEDLI Integrated Sensor Plug)**, In-depth temperature and isotherm sensors embedded in the PICA Thermal Protection System (TPS)
- MEDLI represents the most heatshield instrumentation flown on a Mars mission to date

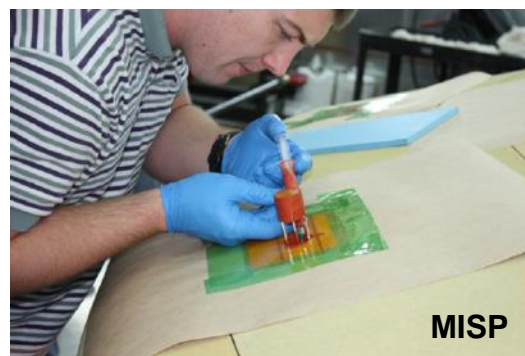
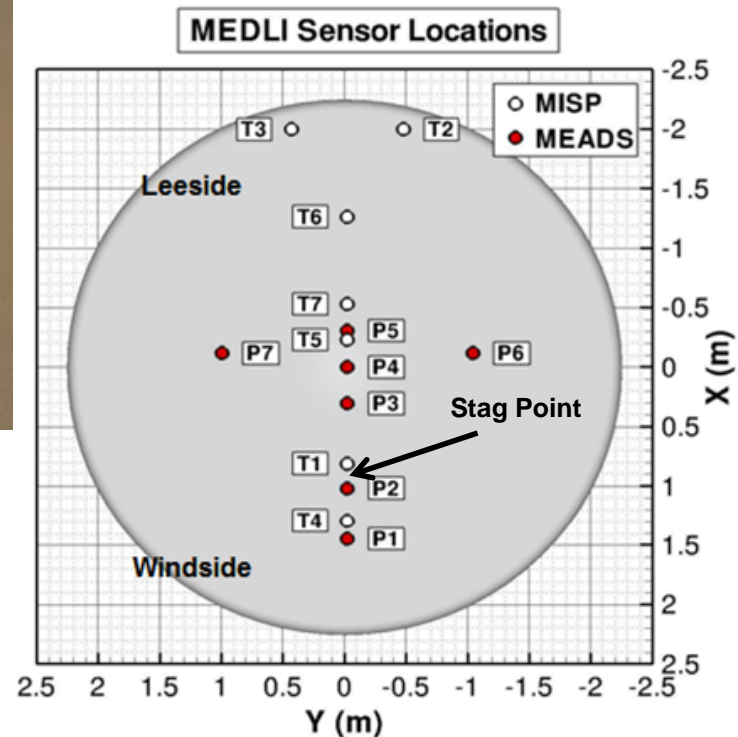

MEDLI Integrated Sensor Plug (MISP)



- Seven MISP plugs installed at different locations on the heatshield covering a wide range of heating environments
- Each MISP is a 1.3" in diameter by 1.14" long PICA plug, inserted in heatshield and bonded on the sides and bottom with RTV-560
- Each MISP plug contains four type-K thermocouples (TC1-4) and one isotherm sensor (HEAT), sampled at 8, 2, or 1 Hz depending on location
 - In Plugs 5 and 7, only the top two thermocouples were operational due to data channel limitations
- Only the TC data are discussed here (HEAT sensor returned noisy data due to a data system issue)

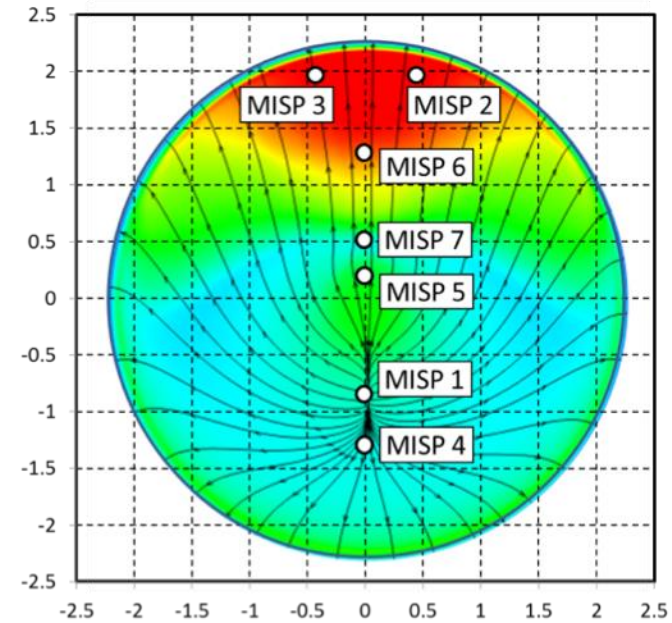

Location of MISP Plugs on Heatshield

MISP Plug

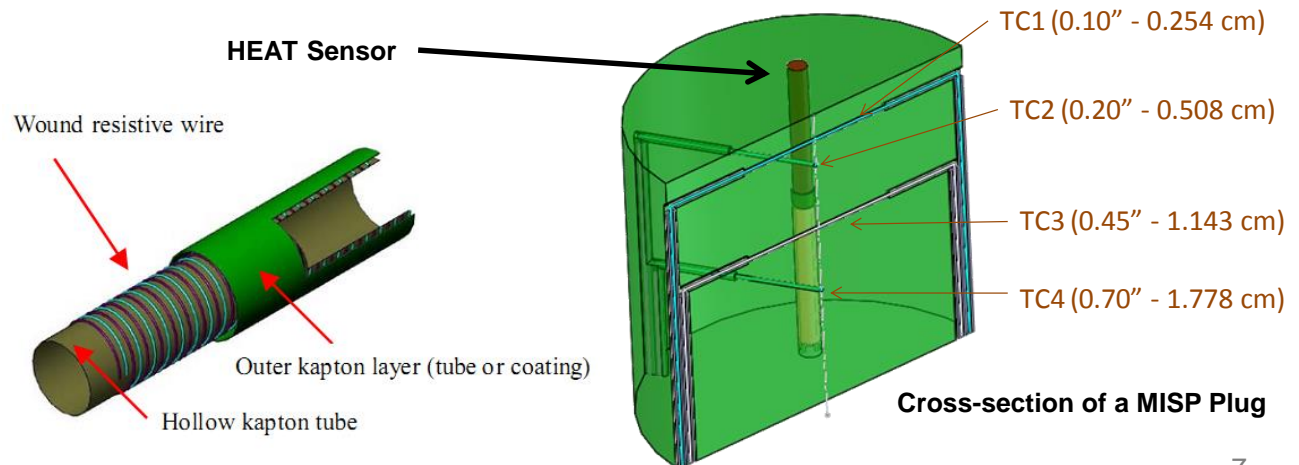

Cross-section of a MISP Plug

MISP Flight Thermocouple Data

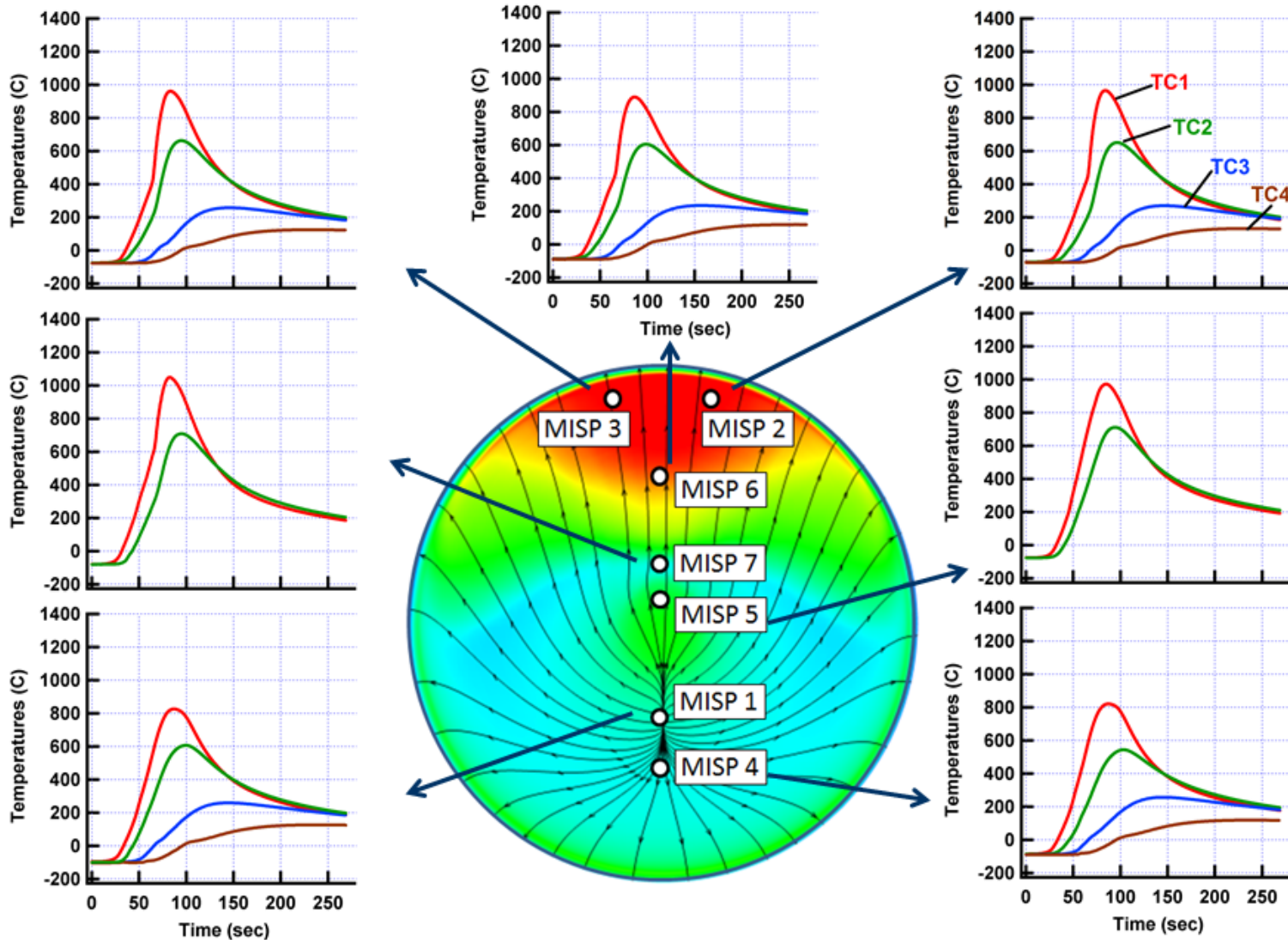

- All thermocouples returned data successfully
- All near surface thermocouples survived the heat pulse → TPS recession < 0.1 inch
- Boundary layer transition observed as sudden temperature slope changes

Boundary Layer Transition



- MSL studies used a momentum thickness Reynolds number (Re_θ) threshold to determine that heatshield will likely experience turbulent heating
 - Ground test data suggested transition for $Re_\theta > 200$
- This led to design to fully turbulent environments at all locations on the heatshield
- Transition time can be inferred from the temperature derivative of shallowest TC
- Boundary layer Reynolds numbers can be calculated using CFD tools on the best estimated trajectory (BET)
- No single value of Re_θ explains transition front speed between MISP3 & MISP7

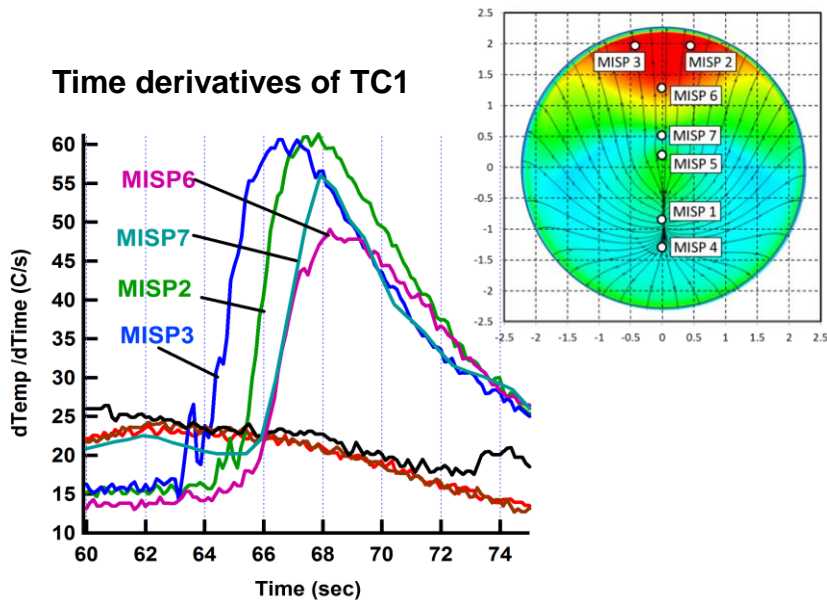

Plug	Inferred transition Time <i>seconds</i>	Predicted Transition Time with $Re_\theta > 200$ <i>seconds</i>	Calculated Re_θ at inferred transition time
MISP3	63	52	394
MISP2	64	52	405
MISP6	65	57	293
MISP7	65	70	158
MISP5	73	No transition	125

Turbulent Transition Due to Roughness



- Transition criterion:

- Transition may also be induced by roughness, described by a Roughness Reynolds (Re_{kk}) number based on roughness height (k)
- Ballistic range studies have shown that CO_2 flows trip at lower Re_{kk} numbers than in air, for both discrete and distributed roughness
 - Transition threshold for distributed roughness in CO_2 : $Re_{kk} > 223 \pm 55$ [Wilder, AIAA 2015-1738]
- Two possible sources of distributed roughness considered for MEDLI: Roughness of PICA & Series of trips from RTV swelling

- Distributed roughness: PICA

- Distributed roughness at design conditions is small (<0.6mm at most)
- Transition not well predicted based on such low roughness heights

- Series of trips: RTV gap fillers swelling

- Flow passed over a series of tile gaps and upstream MISP fences
- RTV fences creates roughness elements as high as 2 mm acting like distributed roughness
- Re_{kk} at flight transition times (for $k = 2$ mm) agrees with threshold derived from ballistic range testing
- However, MISP5 transition still not well predicted (closest to stag point and least affected by upstream trips)



85 W/cm², 0.33 atm 175 W/cm², 0.28 atm 270 W/cm², 0.27 atm

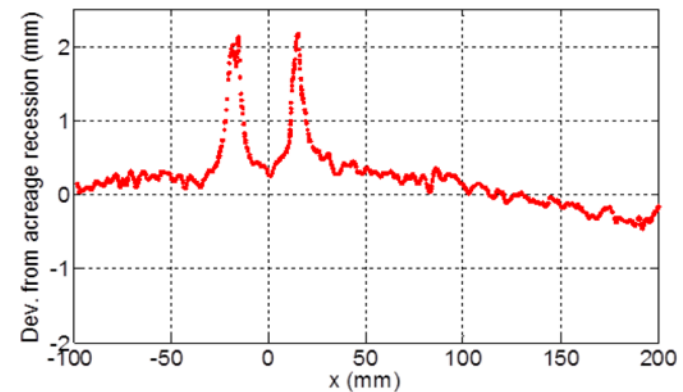

Plug	Inferred Transition Time seconds	Re_{kk} at inferred transition time ($k = 2$ mm)
MISP3	63	198
MISP2	64	219
MISP6	65	230
MISP7	65	211
MISP5	73	525

Model Predictions of In-depth Temperature



- Surface heating is calculated using CFD code DPLR based on best-estimate trajectory
 - Best-estimate environments don't use conservative assumptions made for design environments
 - Mitcheltree and Gnoffo 8-species 12-reactions Mars thermochemical non-equilibrium model
 - Mitcheltree surface catalycity model
 - Turbulent flow is modeled with Baldwin-Lomax algebraic model
 - Surface assumed to be in radiative equilibrium
 - Transition time is inferred from flight data
 - Consistent with design, shock layer radiation is assumed to be negligible
- Material response calculations are performed using Fully Implicit Ablation and Thermal (FIAT) response program
 - Equilibrium gas-surface chemistry is used to solve a surface energy balance that determines recession and conduction into material
 - Analysis is done with and without recession

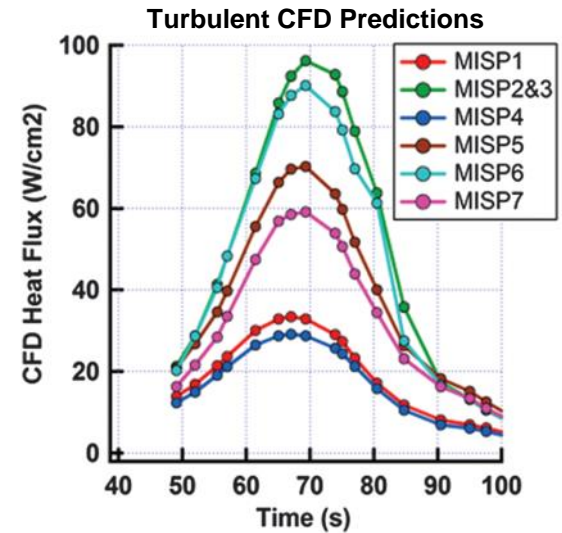
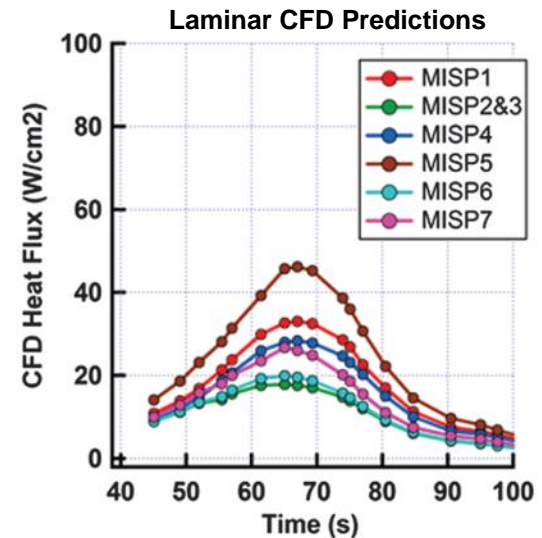

$$C_H(H_r - h_w) + \dot{m}_g h_g + \dot{m}_c h_c - (\dot{m}_c + \dot{m}_g) h_w + \alpha_w q_{rad} - \sigma \epsilon_w (T_w^4 - T_\infty^4) - q_{cond} = 0$$

Comparison of TC Data with Predictions



- TC burnout predicted at four MISP plugs with nominal recession model
 - Equilibrium models known to over predict recession at low conditions
 - Leads to inaccurate prediction of in-depth temperatures

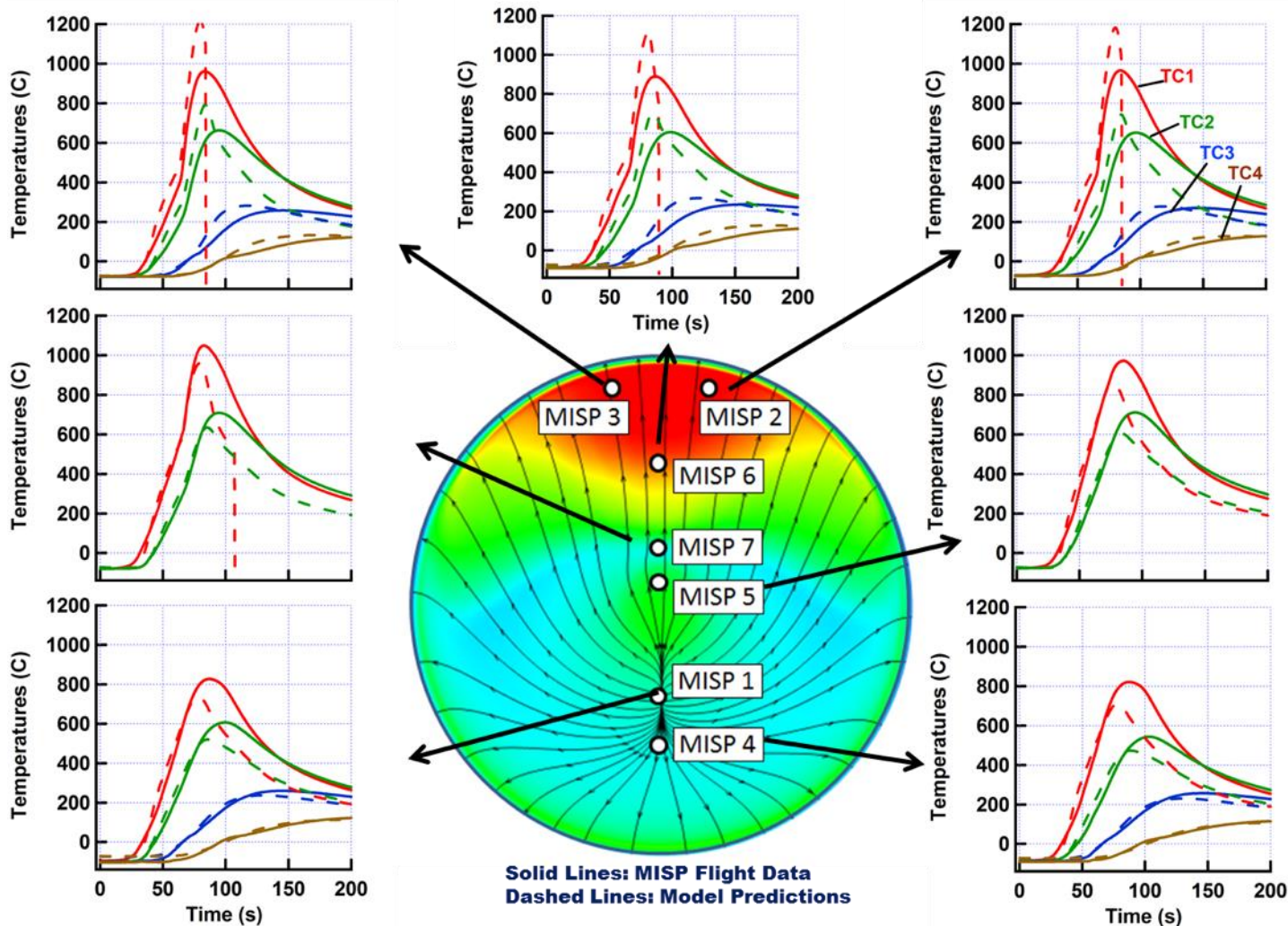

Comparison with Predictions (No Recession)



Turbulent leeside peak temperature matches flight data

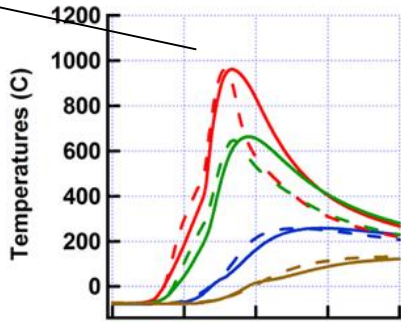

Under prediction of apex heating potentially due to turbulent overshoot or gap filler effects

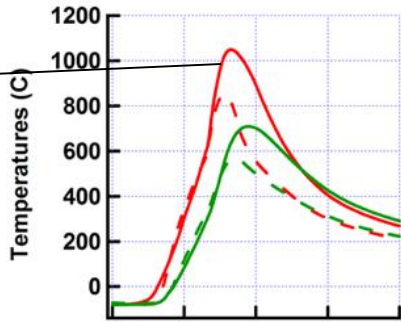

Under prediction of windside laminar heating potentially due to radiation

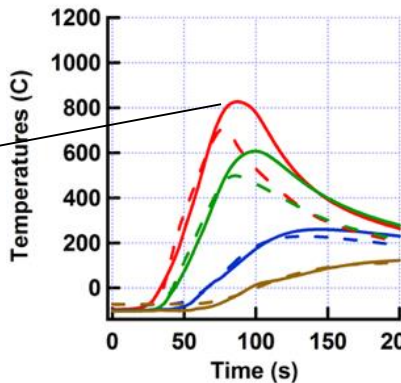

Slower temperature drop in flight data compared to predictions potentially due to radiation or chemistry model deficiency

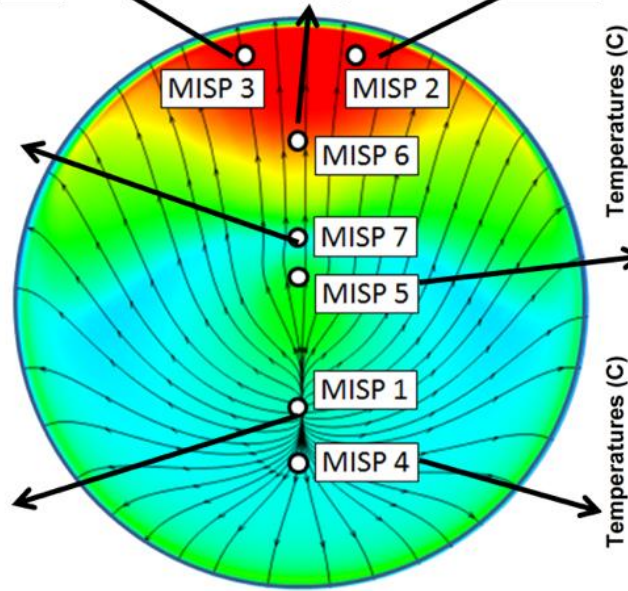
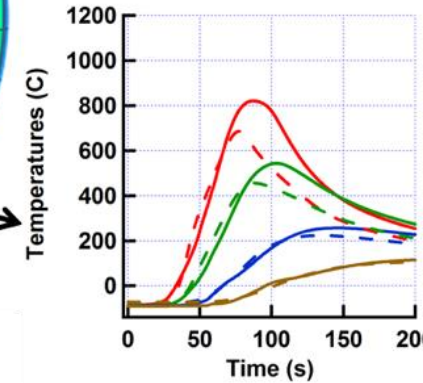
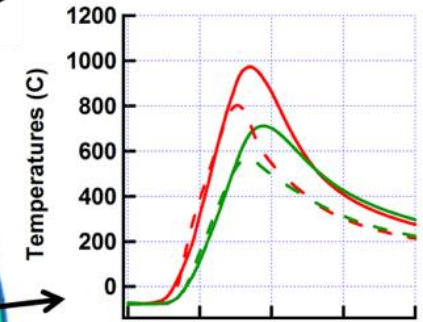
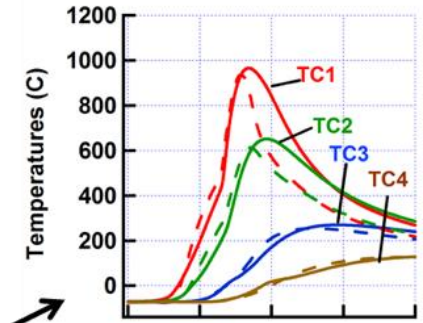
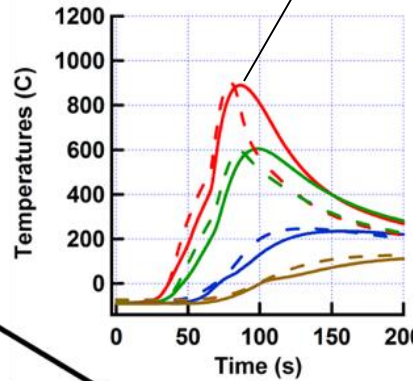

Solid Lines: MEDLI Flight Data
Dashed Lines: Model Predictions

Surface Heating Reconstruction



- Inverse methods can be used to reconstruct surface heating from in-depth temperature data
 - The surface heating is estimated by minimizing the difference between temperature predictions and TC flight data (iterative process)
 - Gauss-Newton method for minimization
 - Tikhonov first-order regularization to alleviate oscillations

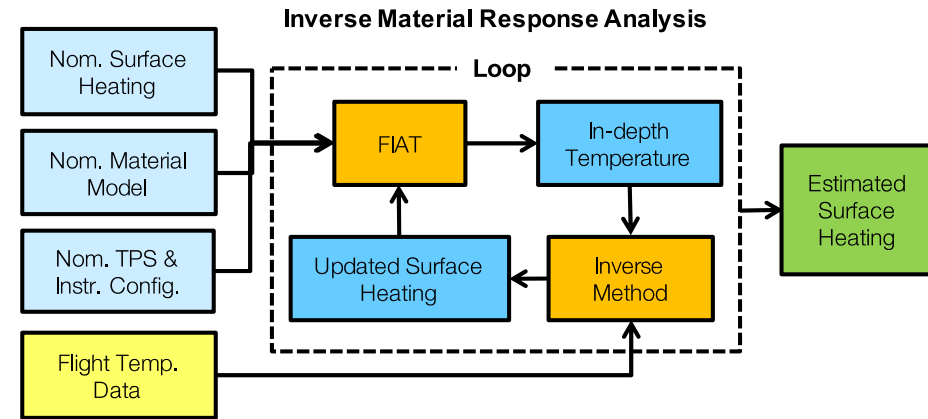

- Two estimation approaches were pursued:

1. Estimate surface film coefficient, C_H , using a detailed energy balance equation and equilibrium chemistry model for TPS material

$$C_H(H_r - h_w) + \dot{m}_g h_g + \dot{m}_c h_c - (\dot{m}_c + \dot{m}_g) h_w + \alpha_w q_{rad} - \sigma \epsilon_w (T_w^4 - T_\infty^4) - q_{cond} = 0$$

2. Estimate heat rate using a simplified energy balance equation assuming no surface recession

$$q_s + \alpha_w q_{rad} - \sigma \epsilon_w (T_w^4 - T_\infty^4) - q_{cond} = 0$$

Challenges with C_H Estimation



- The PICA equilibrium chemistry model is known to be inaccurate for MSL low heating conditions and tends to overestimate surface recession
 - Flight data suggest that recession was less than 0.1" (TC1 depth) at all plugs
 - PICA equilibrium model predicts recession advancing deeper than TC1 depth
- Inaccuracy of the equilibrium model also results in an inaccurate estimation of wall enthalpy
 - Wall and edge enthalpy approach one another at ~85 s
 - The convective term approaches zero and the in-depth thermal response loses sensitivity to C_H
- There is no validated finite-rate gas-surface chemistry model for PICA in CO_2 yet

$$C_H(H_r - h_w) + \dot{m}_g h_g + \dot{m}_c h_c - (\dot{m}_c + \dot{m}_g) h_w + \alpha_w q_{rad} - \sigma \epsilon_w (T_w^4 - T_\infty^4) - q_{cond} = 0$$

Predicted Edge and Wall Enthalpy at MISP 2

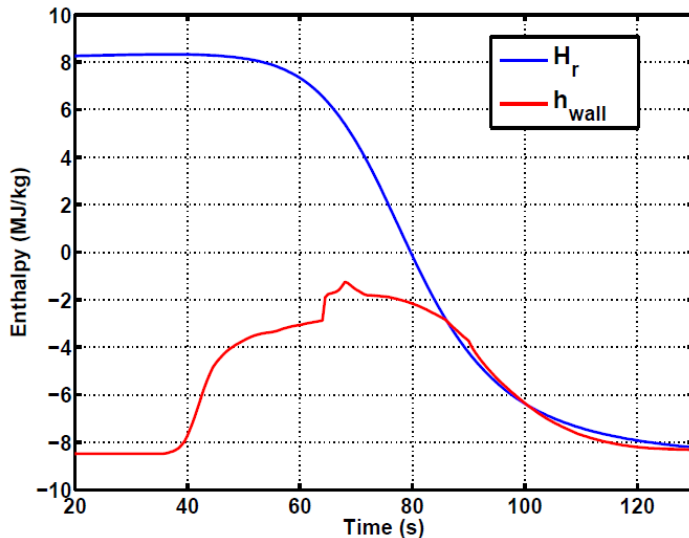

C_H Estimation at MISP2

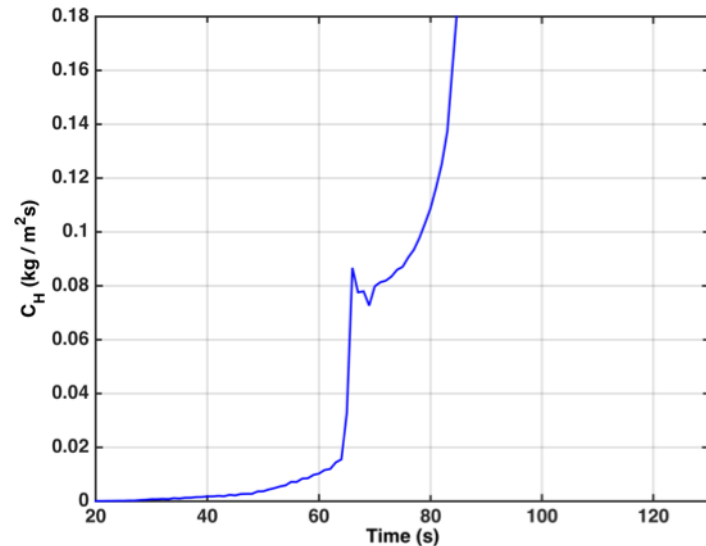

Heat Rate Estimation Assuming No Recession



- A more simplified energy balance equation is also implemented in FIAT which does not require the PICA ablation model
 - Allows reconstruction of net heat rate (not directly comparable with CFD convective heat flux)
 - Assumes zero surface recession

$$q_s + \alpha_w q_{rad} - \sigma \epsilon_w (T_w^4 - T_\infty^4) - q_{cond} = 0$$

- MISP5 experienced the highest heating before transition (consistent with laminar predictions)
- MISP7 experienced higher turbulent heating than predictions
- Performed recession sensitivity and Monte Carlo analysis to assess reconstruction uncertainty (Mahzari et al., JSR 2015)

Regularized Heat Rate Estimate

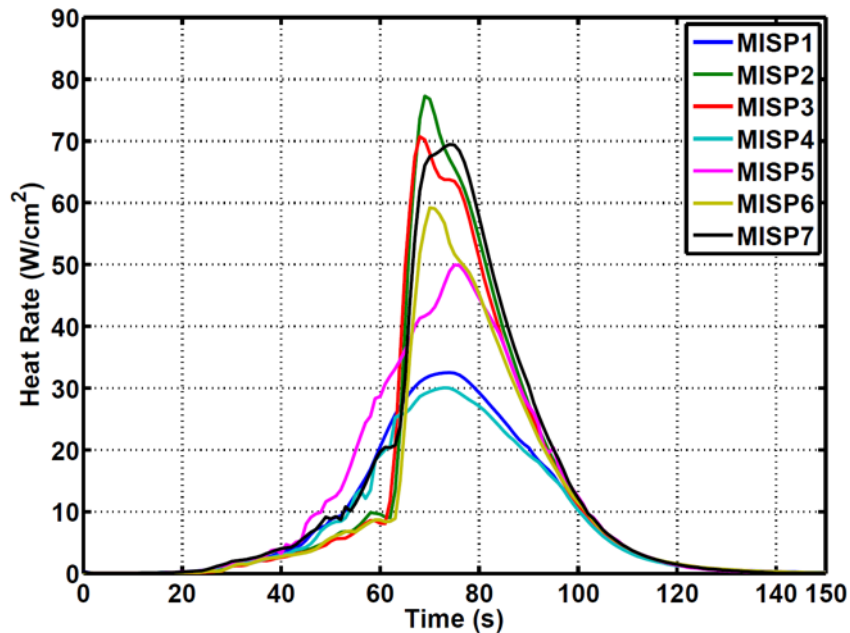

MISP Plug Layout

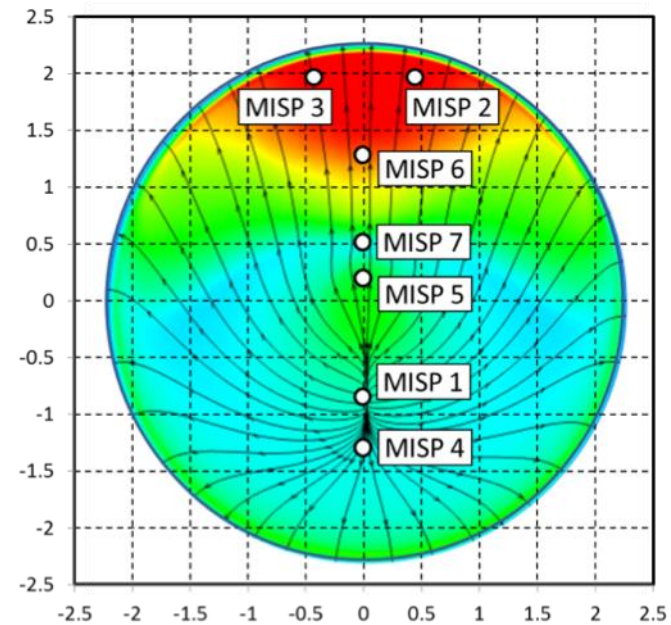

Follow-on Studies: Shock Layer Radiation



- Radiative heating was thought to be negligible during design
 - Simulations predicted $< 1 \text{ W/cm}^2$
- Missing mechanism: high CO_2 density at moderately high temperatures (3000-4000 K) leads to radiation from CO_2 vibrational modes
 - Peaks later in trajectory
- Cruden et al. performed shock tube tests and simulations to characterize MSL's radiative heating
 - Significant mid-infrared radiation resulting in additional heat flux as high as 15 W/cm^2
- Including radiation in predicted heating improves the match with heating inferred from flight in stagnation region, but doesn't explain all the discrepancy
 - Remaining discrepancy most likely due to deficiency of equilibrium gas-surface chemistry model

Cruden et al., "Radiative Heating During Mars Science Laboratory Entry: Simulation, Ground Test, and Flight", *Journal of Thermophysics and Heat Transfer*, July 2016, Vol. 30, No. 3

Radiance Calculated from Shock Tube Tests Run at MSL Flight Conditions

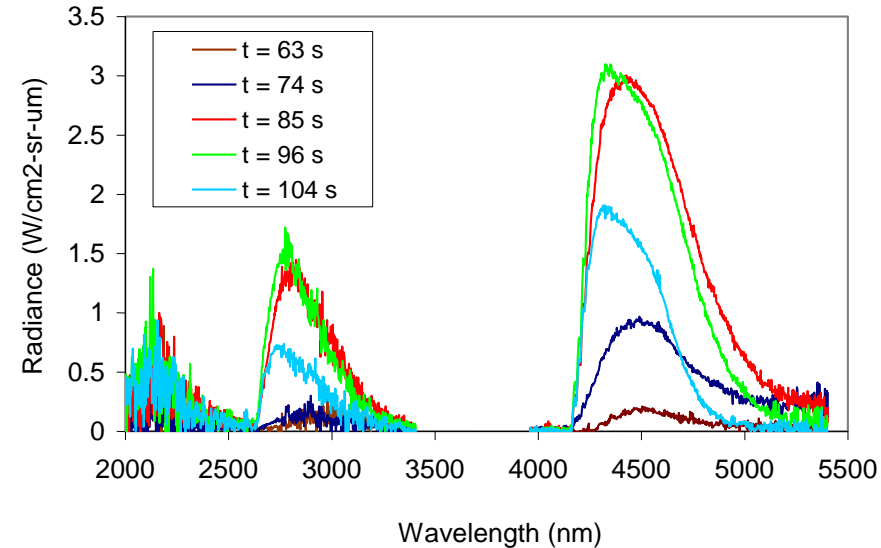

Comparison of Predicted and Inferred Heating at MISP1 in Stagnation Region

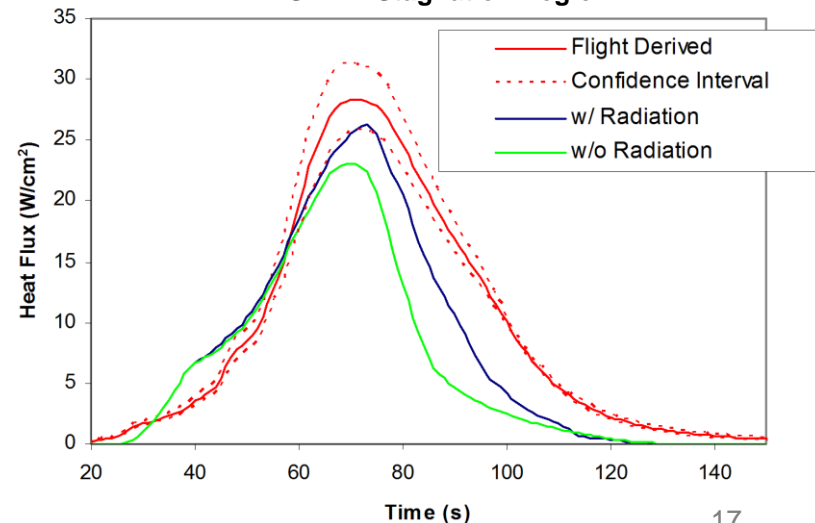

Follow-on Studies: Recession Model



- In a recent study, Oliver employed a decoupled technique to reconstruct surface heating with kinetically limited recession models
- This technique allows for C_H reconstruction without being limited by the equilibrium model
 - More straightforward to compare C_H with CFD predictions
- Performed sensitivity studies by varying different model inputs and identified feasible solutions based on flight's upper bound on recession

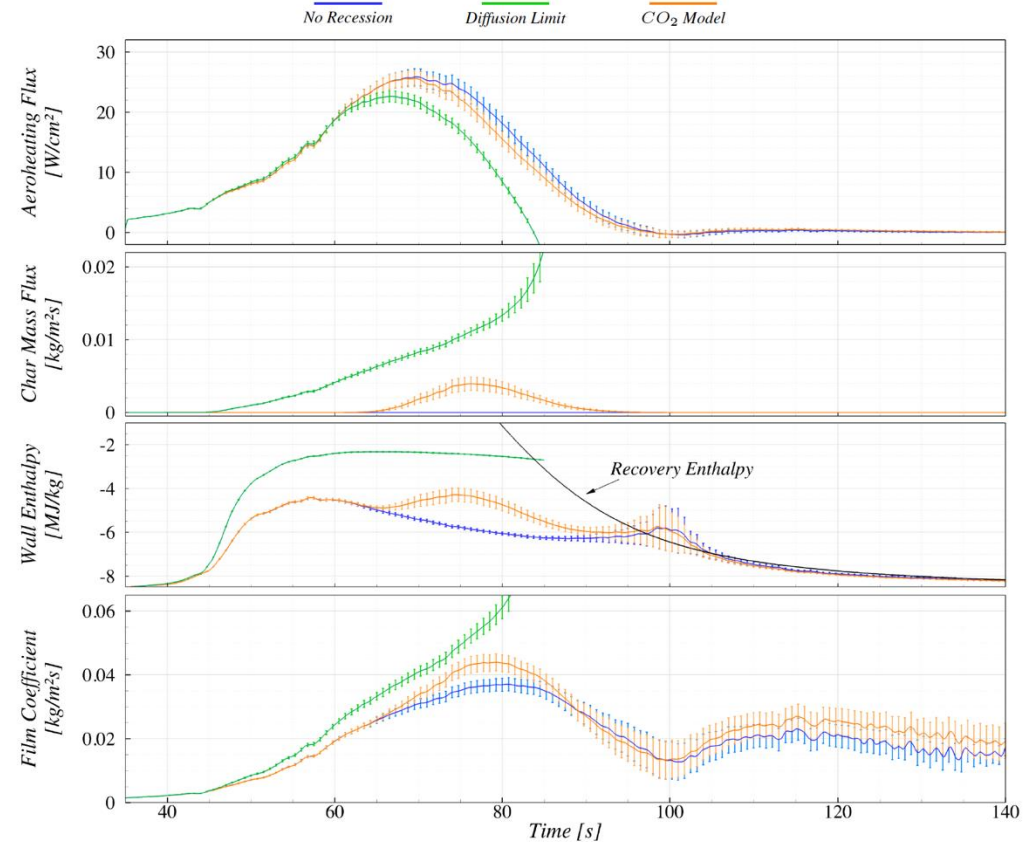

Oliver, B., "Decoupled Method for Reconstruction of Surface Conditions From Internal Temperatures On Ablative Materials With Uncertain Recession Model," 47th AIAA Thermophysics Conference, AIAA 2017-3685

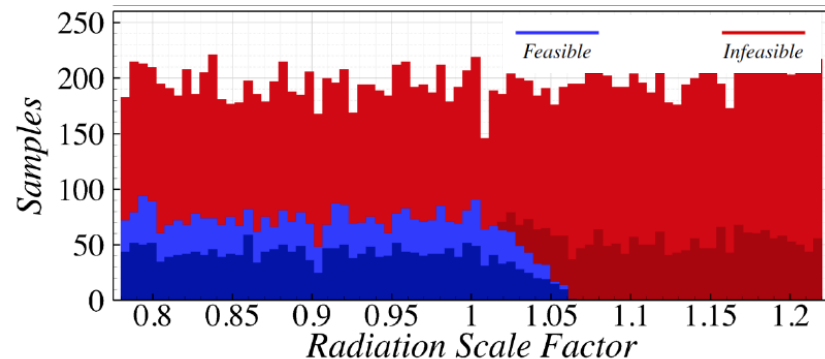

Summary of Findings from MISP Data



- Aeroheating
 - MSL designed to fully turbulent; flight data clearly shows turbulent transition and heating
 - Front progression is consistent with roughness-induced transition due to RTV swelling
 - Heating near stagnation region is underpredicted (partially explained by radiation)
 - Heating near apex region is underpredicted by smooth-wall CFD; higher heating may have been caused by RTV protuberance, currently being investigated
 - Heating predictions in the leeside flank region agree well with flight heating (under assumption of negligible recession)
- Material Response
 - Overprediction of PICA recession by equilibrium models at MSL conditions
 - No evidence of augmented recession in shear conditions
 - Underprediction of TC temperatures during cool-down is possibly due to deficiency of equilibrium recession model
 - The in-depth response model performs reasonably well in predicting temperatures
 - Early rise and plateau behavior that is often observed in arcjet TC data at low temperatures also occurred in flight

MEDLI2



- Mars2020 mission will use the same entry vehicle design as MSL and will be instrumented with MEDLI2 sensors
- MISP sensors
 - 11 plugs in PICA heatshield containing 17 TCs (better mapping of transition front compared to MEDLI)
 - 6 plugs in SLA-561V backshell containing 7 TCs
 - 3 heat flux sensors in the backshell (2 total flux, 1 radiative)
- MEADS sensors
 - 1 hypersonic and 6 supersonic pressure transducers in the heatshield
 - 1 pressure transducer on the backshell
- Post-flight analysis will incorporate improved models and lessons learned from MEDLI

TC Plugs in PICA and SLA



Heat Flux Sensor



Pressure Transducers



Instrument Layout on Heatshield

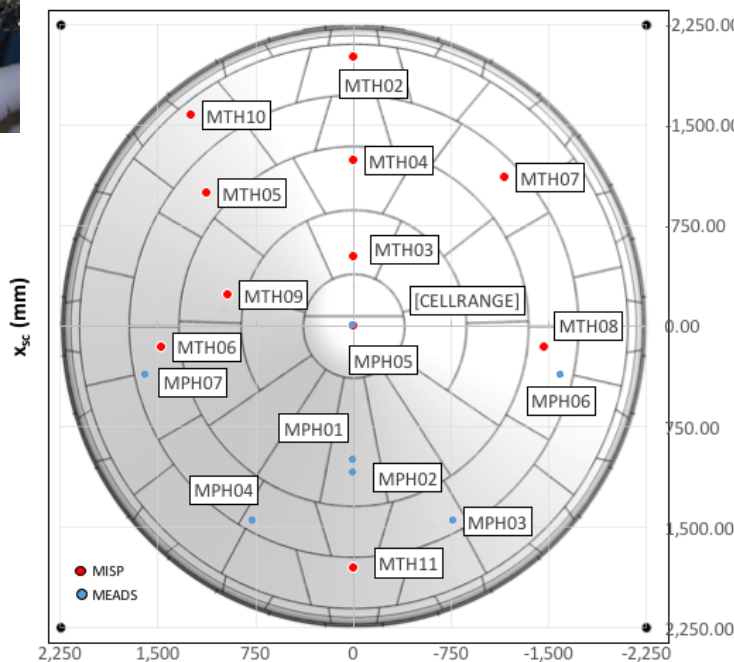

Instrument Layout on Backshell

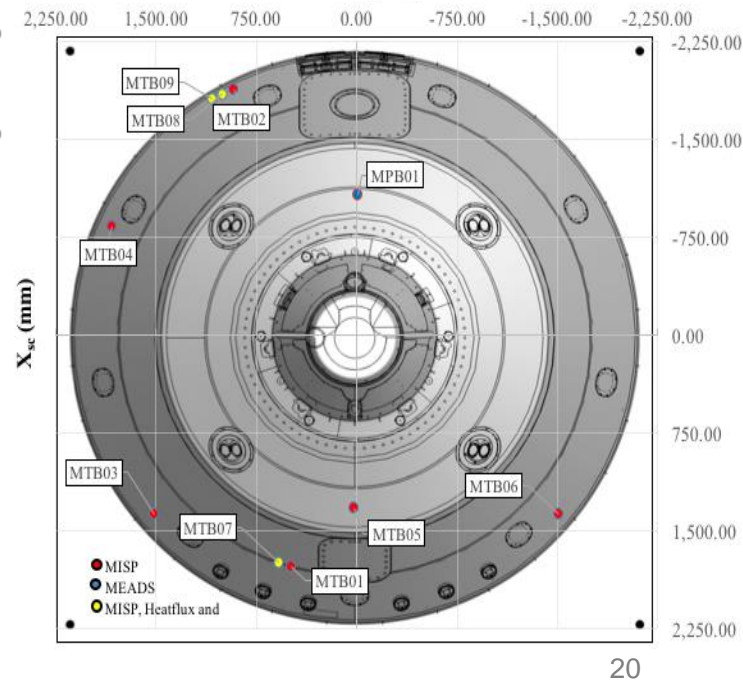

Further Reading



- Gazarik, M., et al., “Overview of the MEDLI Project,” IEEE Aerospace Conference, IEEE 2008-1510.
- Edquist, K., et al., “Aerothermodynamic Design of the Mars Science Laboratory Heatshield,” 41st AIAA Thermophysics Conference, AIAA 2009-4075.
- Beck, R., et al., “Development of the Mars Science Laboratory Heatshield Thermal Protection System,” 41st AIAA Thermophysics Conference, AIAA 2009-4229.
- Wright, M., “Sizing and Margins Assessment of the Mars Science Laboratory Aeroshell Thermal Protection System,” 41st AIAA Thermophysics Conference, AIAA 2009-4231.
- Mahzari, M., et al., “Preliminary Analysis of the Mars Science Laboratory's Entry Aerothermodynamic Environment and Thermal Protection System Performance,” 51st AIAA Aerospace Sciences Meeting, AIAA 2013-0185.
- Mahzari, M., et al., “Inverse Estimation of the Mars Science Laboratory Entry Aeroheating and Heatshield Response,” Journal of Spacecraft and Rockets, 2015, Vol.52, No. 4.
- White, T., et al., “Post-flight Analysis of Mars Science Laboratory's Entry Aerothermal Environment and Thermal Protection System Response,” 44th AIAA Thermophysics Conference, AIAA 2013-2779.
- Bose, D., et al., “Mars Science Laboratory Heat Shield Instrumentation and Arc Jet Characterization,” 44th AIAA Thermophysics Conference, AIAA 2013-2778.
- Cruden et al., “Radiative Heating During Mars Science Laboratory Entry: Simulation, Ground Test, and Flight ”, Journal of Thermophysics and Heat Transfer, 2016, Vol. 30, No. 3.
- Oliver, B., “Decoupled Method for Reconstruction of Surface Conditions From Internal Temperatures On Ablative Materials With Uncertain Recession Model,” 47th AIAA Thermophysics Conference, AIAA 2017-3685.
- Hwang, H., et al., “Mars 2020 Entry, Descent, and Landing Instrumentation (MEDLI2),” 46th AIAA Thermophysics Conference, AIAA 2016-3536.

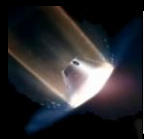

Questions?



Backup

HEAT Sensor Data

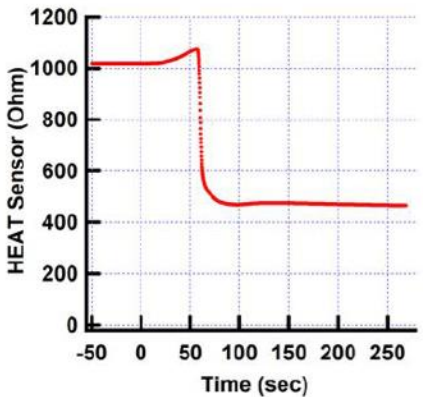
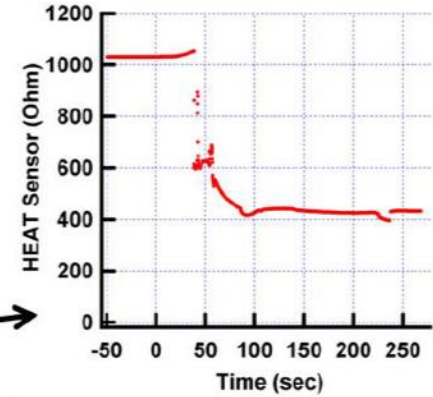
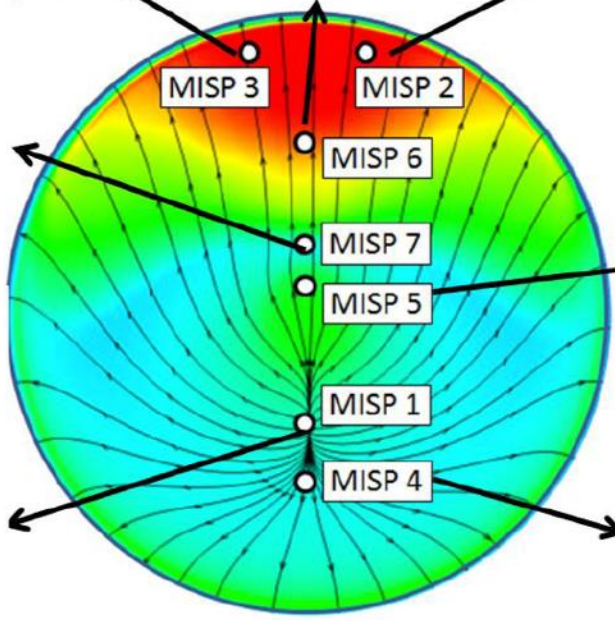
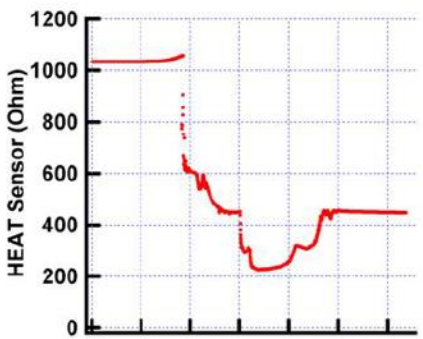
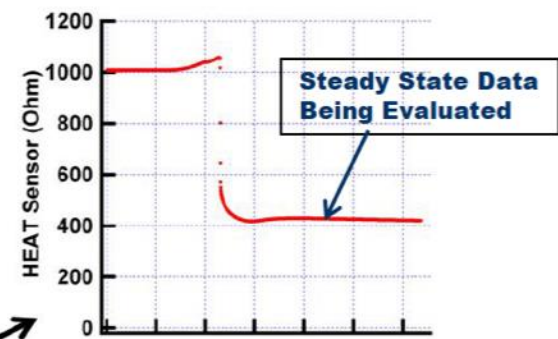
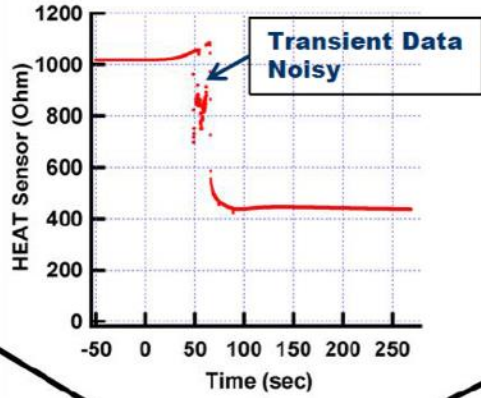
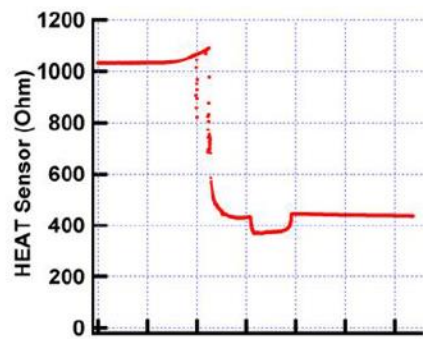

MISP4 HEAT sensor not wired

MISP Plugs Against Tile Layout



- Flow may cross many gap fillers and other plugs before reaching a MISP plug

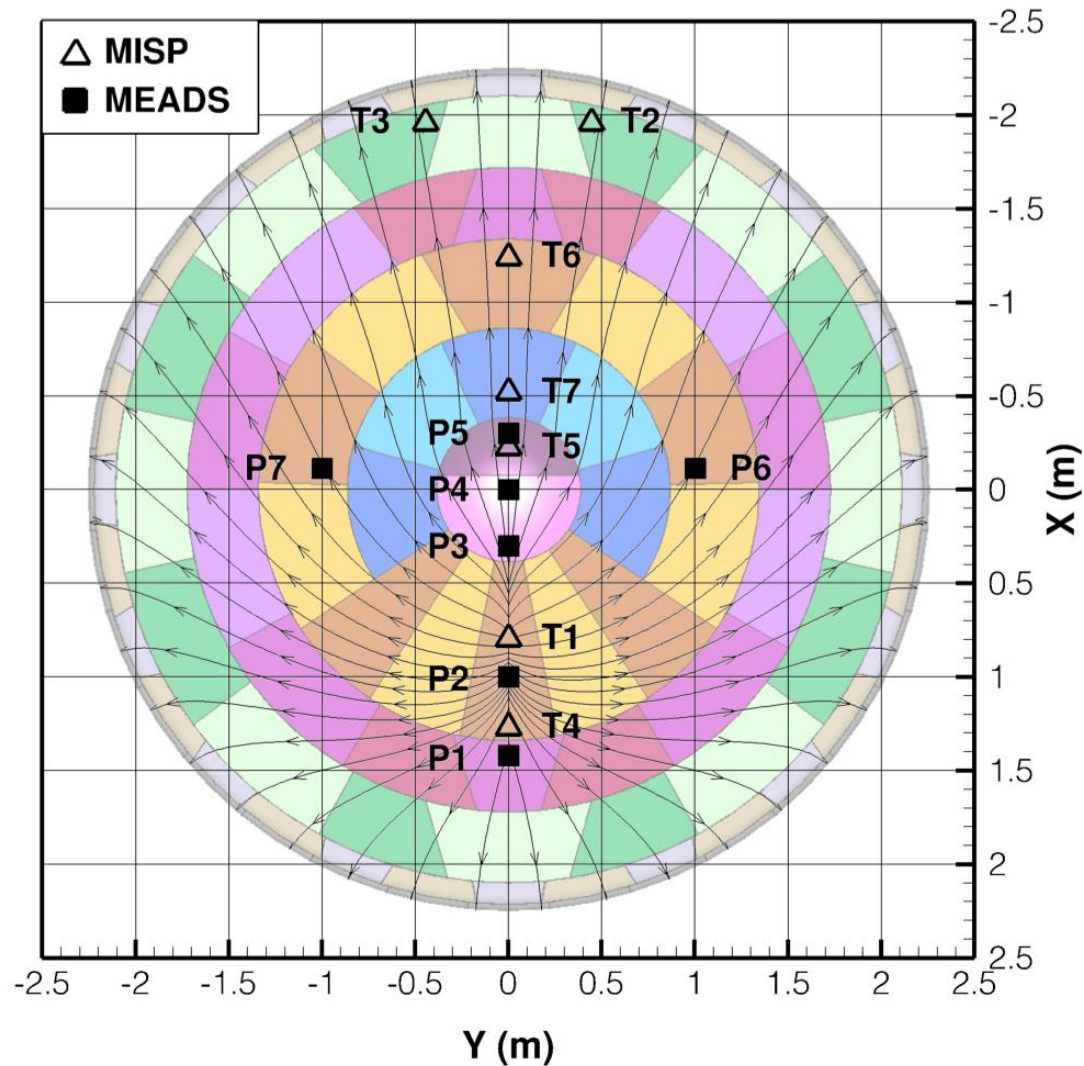

Sensitivity to Recession Uncertainty



- Employ a decoupled approach to investigate the effect of recession on heating estimates
- Reconstruction of heat rate profile from in-depth temperature measurements yields a unique solution for the temperature field in the ablator (regardless of surface location)
- After reconstruction, net heat rate can be calculated for any given surface location at any given time
- Definition of a recession profile will yield a surface heating profile
- In the absence of any recession data, we defined the recession profile based on the scaling of the nominal FIAT equilibrium model predictions

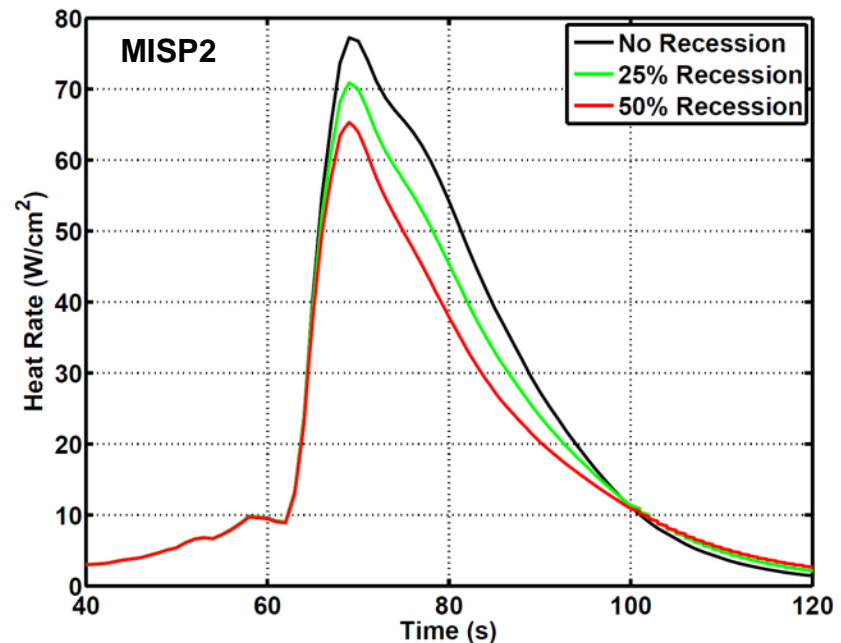
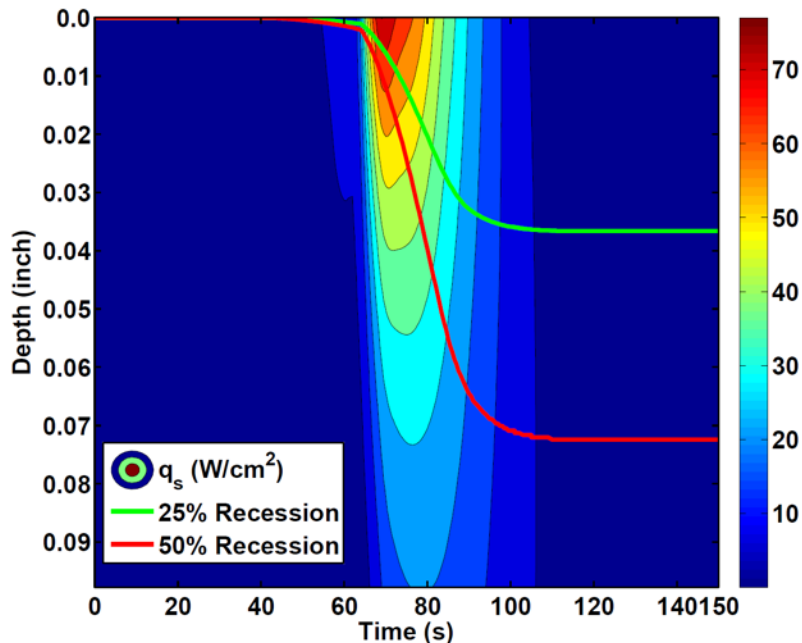

Heat Rate Reconstruction Uncertainty



- Monte Carlo simulation performed around the inverse estimation routine to quantify uncertainty bounds with heat rate estimates
 - Gaussian distributions for eight input parameters based on material property testing and engineering judgment
 - The MC simulation does not include recession uncertainty

Parameter	Std. Dev. (% of nominal)	Parameter	Std. Dev. (% of nominal)
ρ_v	0.75%	Char yield	1% (corr.)
Cp_v	4%	Cp_e	1%
κ_v	7.5%	κ_e	10% (corr.)
$\epsilon_{v,c}$	1.5%	TC1 depth error	0.0015 inch

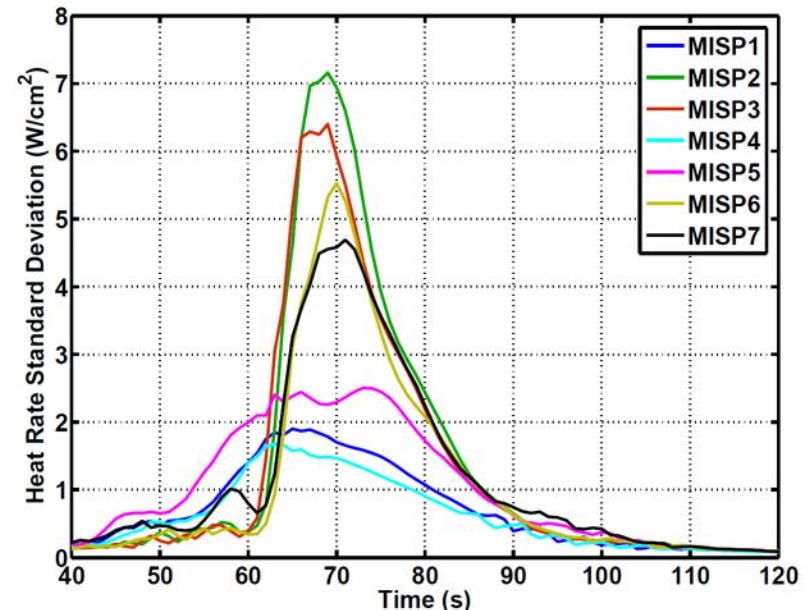
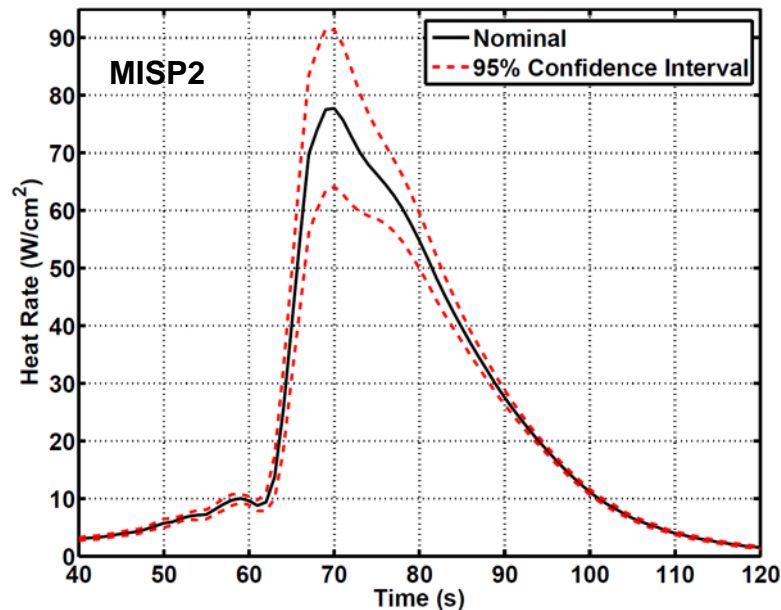

Anchoring ablator simulations with TC data

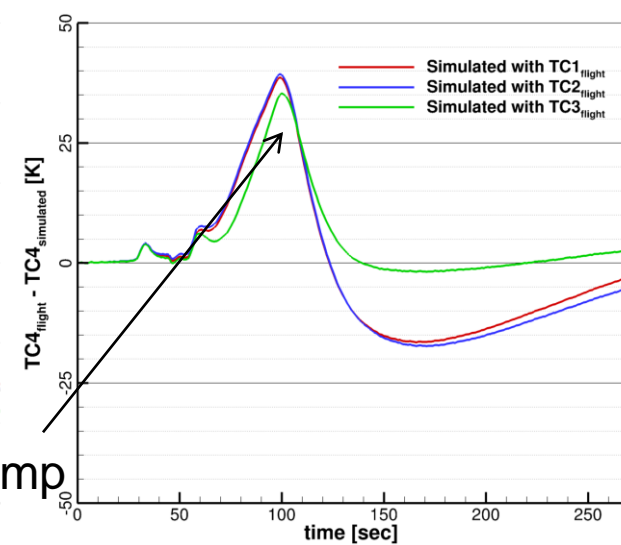
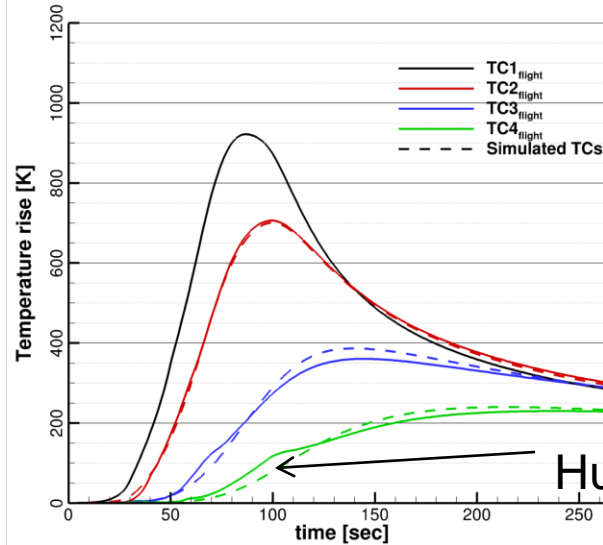
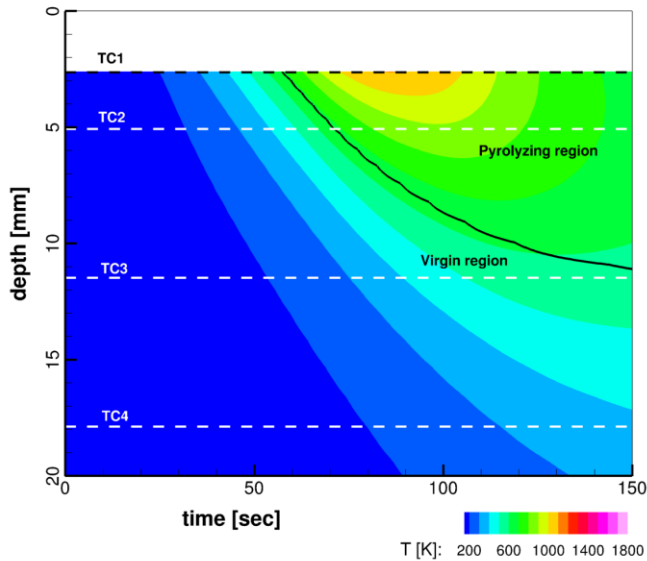

- A direct method of analyzing TPS response is to solve only in-depth heat conduction model
 - Perform this analysis with the FIAT (Fully Implicit Ablation and Temperature) 1-D model, using the PICA model
 - Use flight TC data as a temperature boundary condition to anchor the solution, so-called “TC driver” method
 - Every TC is a potential boundary condition, so several TC drivers are possible for each MISP
- We find that our ability to predict a TC response improves the closer the anchoring TC becomes
- Some phenomena are not well-predicted by the model, including the “hump” observed in the two deepest TCs at all MISP
- We can predict the response of deeper TCs well within ± 50 K in all plugs

National Aeronautics and
Space Administration

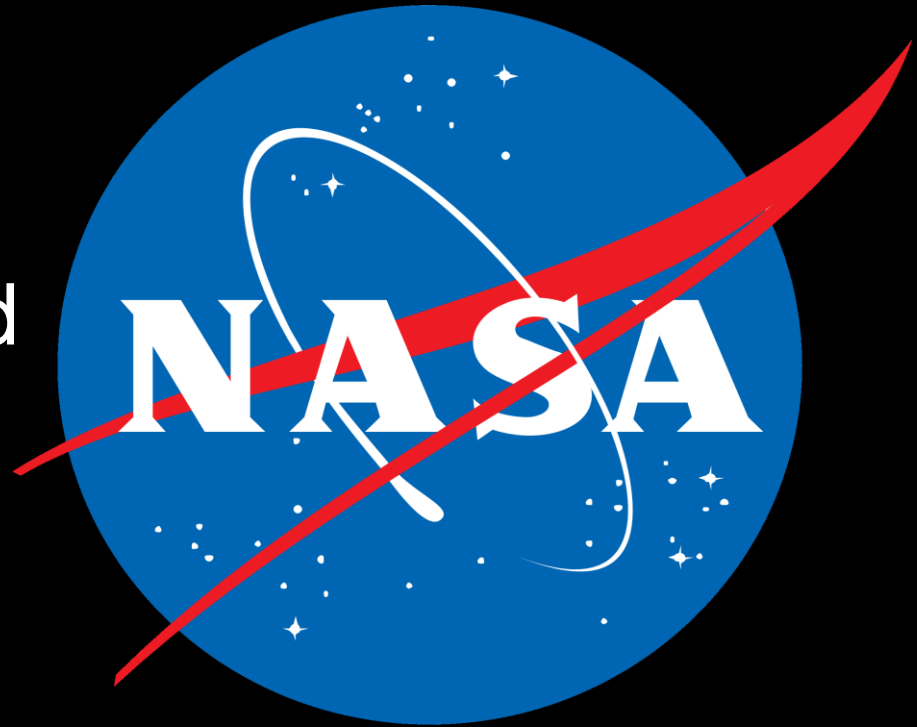

Ames Research Center
Entry Systems and Technology Division