

A Spaceflight Experiment to Determine the Effect of Chamfered Sample Holders on Atomic Oxygen Erosion

Kshama Girish¹, Bruce A. Banks² and Kim K. de Groh³

¹Hathaway Brown School, 19600 North Park Blvd, Shaker Heights, OH 44122, ²SAIC at NASA Glenn Research Center, Cleveland, ³NASA Glenn Research Center, Cleveland, OH.

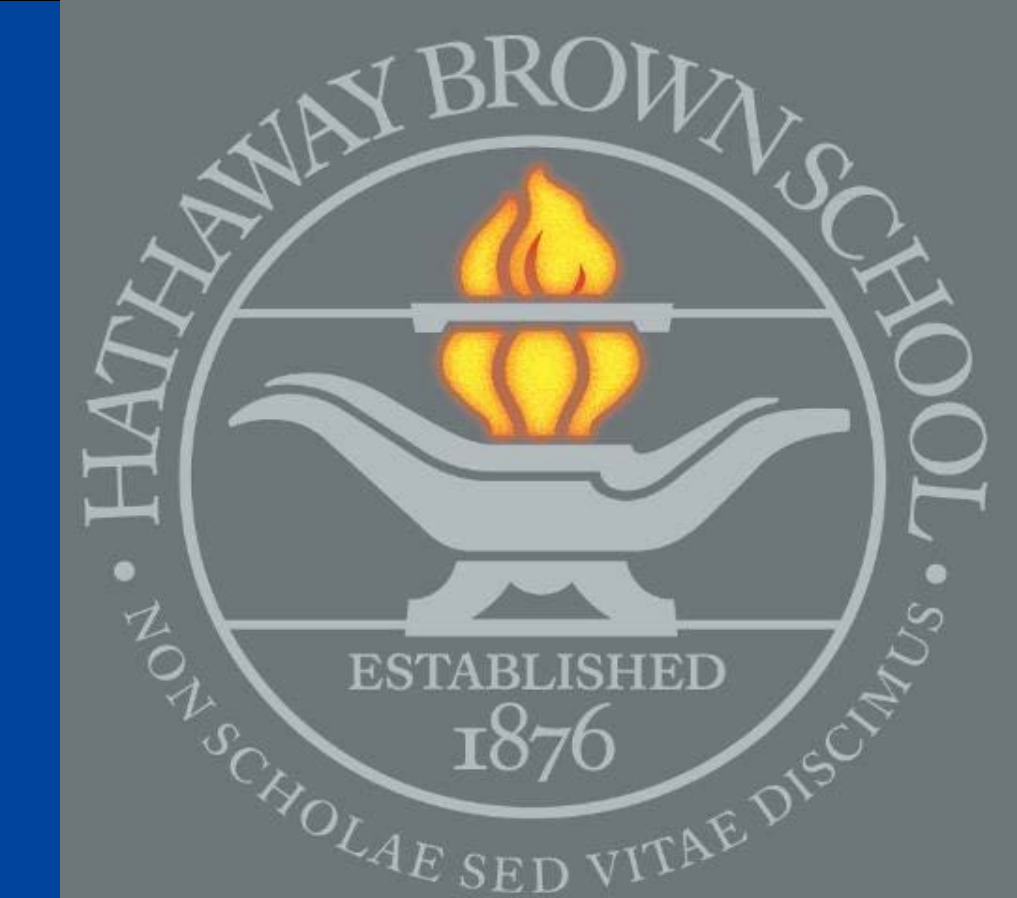

ABSTRACT

The exteriors of low Earth orbit (LEO) spacecraft are subjected to many environmental threats that can cause the surface materials to degrade. One of these threats is atomic oxygen (AO), which is formed by photo dissociation of molecular oxygen by energetic UV radiation. Atomic oxygen exposure can result in oxidative erosion of polymers leading to structural or thermal failure of spacecraft components. The amount of AO erosion expected during a mission can be calculated by knowing the AO erosion yield (E_y , volume loss per incident atom) of the material and the AO fluence expected for the mission. The E_y can be determined through dehydrated mass loss measurements of test samples if one knows the AO fluence, density, and exposure area. Such measurements have been made as part of flight experiments, including the Materials International Space Station Experiment 2 (MISSE 2) Polymers Experiment. The MISSE 2 Polymers Experiment sample holders had chamfered circular apertures that controlled the exposure area, but also allowed some additional AO to scatter from the chamfered edges onto the samples thus causing some samples to erode thru and peel at their perimeter due to this scattering effect. By modeling the scattered AO flux one can predict the actual total AO fluence, and hence more accurate sample E_y . Sample holders with different chamfered-perimeter to exposed-area ratios have been designed for future spaceflight experiments that allow a more accurate determination of the E_y for large area polymers, representative of their use on spacecraft surfaces.

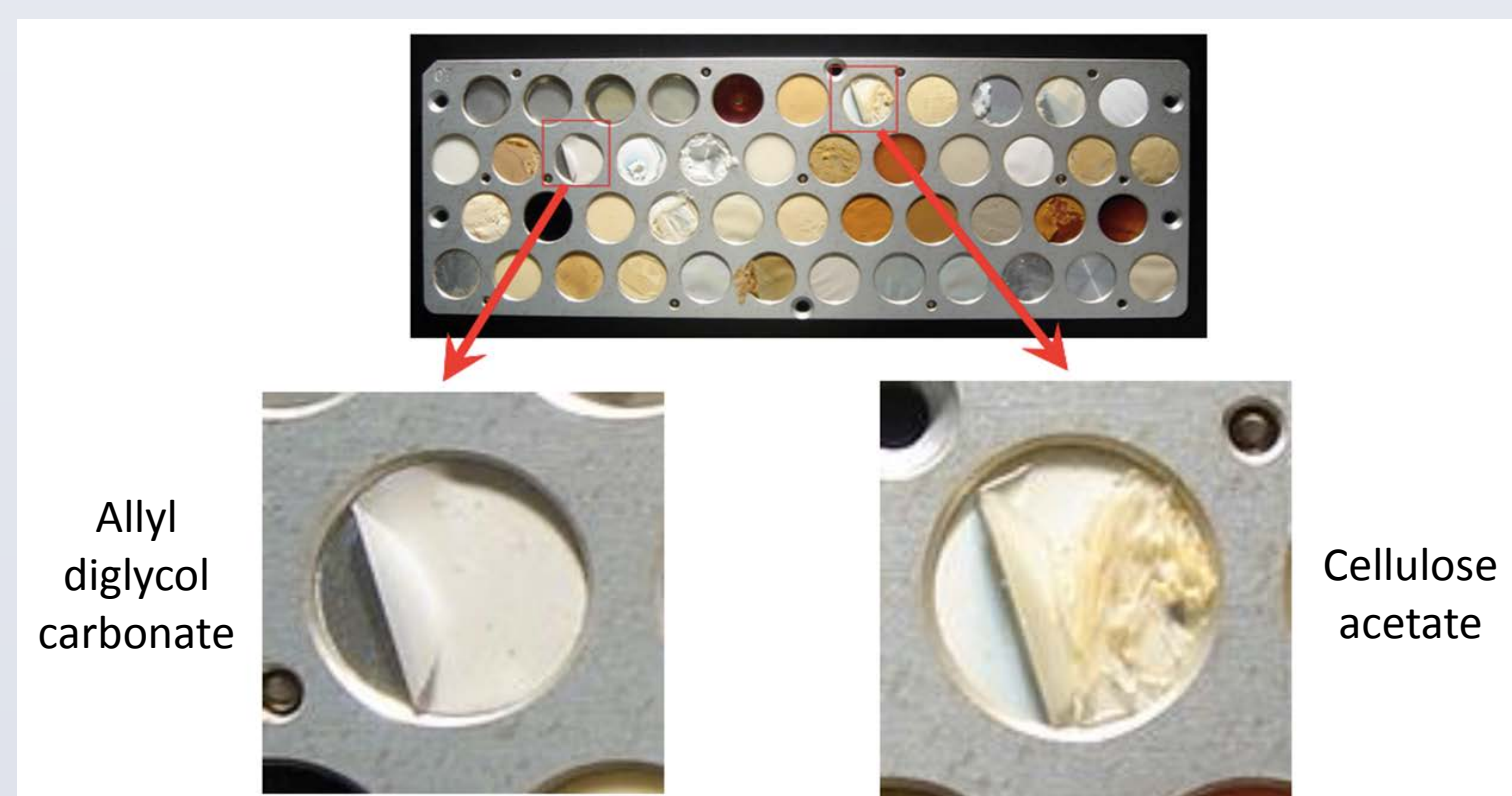

Figure 1: MISSE 2 Polymers Experiment post-flight sample perimeter peeling due to scattering from chamfered sample holders. (Ref 1)

Figure 1 shows a MISSE 2 Polymers Experiment sample peeling. Figure 2 shows a section view of the profile of a polyethylene oxide sample from the MISSE 2 experiment. This shows the results of excessive AO erosion, at the edges of the sample, due to AO scattering from the chamfered sample holder. This added to the normal incident AO flux.

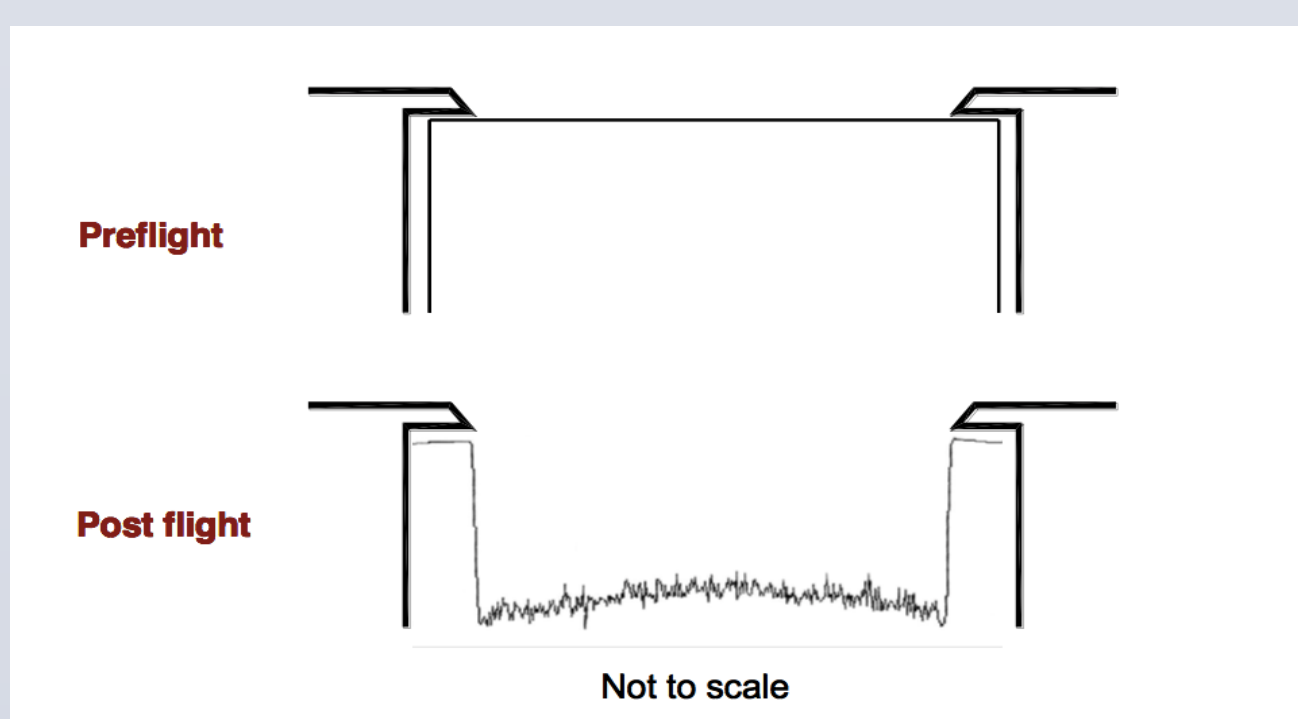

Figure 2: Surface profile of a polyethylene oxide sample from the MISSE 2 experiment. (Ref 1)

As illustrated in Figure 3, the AO flux scattering off the chamfered edges of the sample holders adds to the flux arriving at the samples which causes them to locally erode at a faster rate than occurs near the center of the samples.

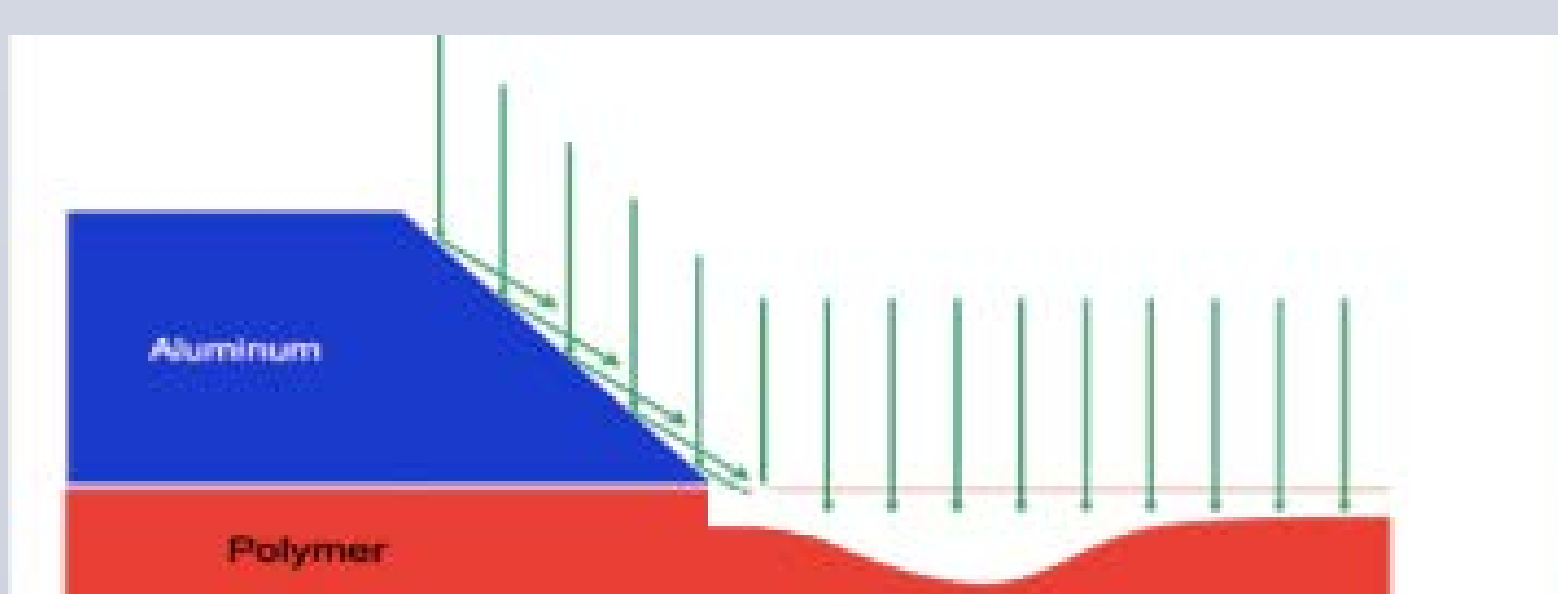

Figure 3: Diagram of chamfered sample holder showing the effect of AO scattering.

OBJECTIVE

The MISSE 2 Polymers Experiment sample holders had chamfered circular apertures that controlled the exposure area, but also allowed AO to scatter from the chamfered surfaces onto the samples. This scattering increases the local flux and therefore results in an E_y which is higher than simply computing it based on the exposed sample area. As a consequence, some MISSE 2 samples peeled at their edges due to this scattering effect. The objective of the overall experiment is to use sample holders with different chamfered-perimeter to exposed-area ratios. This is to enable accurate determination of the E_y as a function of sample diameter to enable the prediction of E_y for large area polymers representative of their functional use on spacecraft surfaces.

DESIGN

The intent of the design is to determine the effect on AO erosion yields based on testing flight samples with different diameter chamfered sample holders.

Approach: Measure the erosion yields using sample holders with different chamfered-perimeter to exposed-area ratios with identical materials and chamfers. Using resulting data and trend lines develop an extrapolation tool to correct E_y for arbitrary sample size in chamfered holders. Use both polyimide (Kapton H) and polyoxymethylene (Delrin) for test samples because they have very different erosion yields which may have an impact on the results.

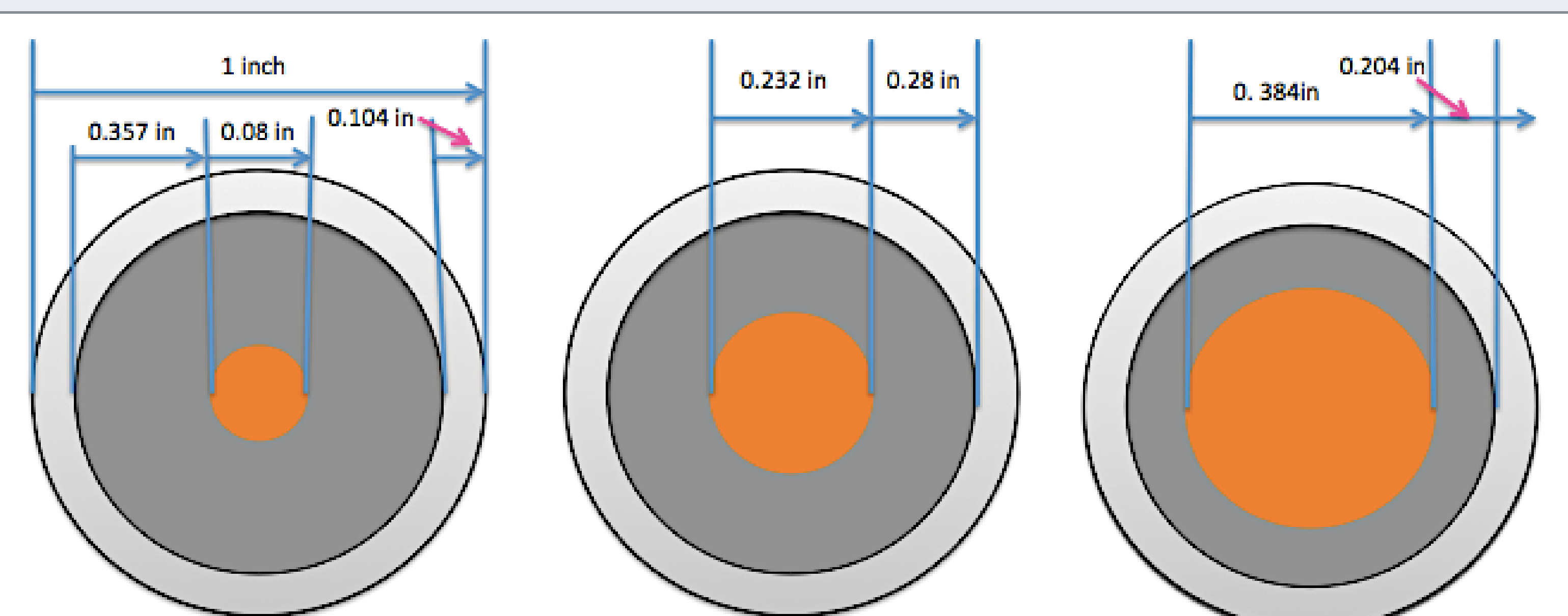

This is a top view of the selected flight sample holder design. The orange can either represent Kapton H or Delrin. The outer most silver ring represents the standard plate holder. The gray ring represents the three designed attachments.

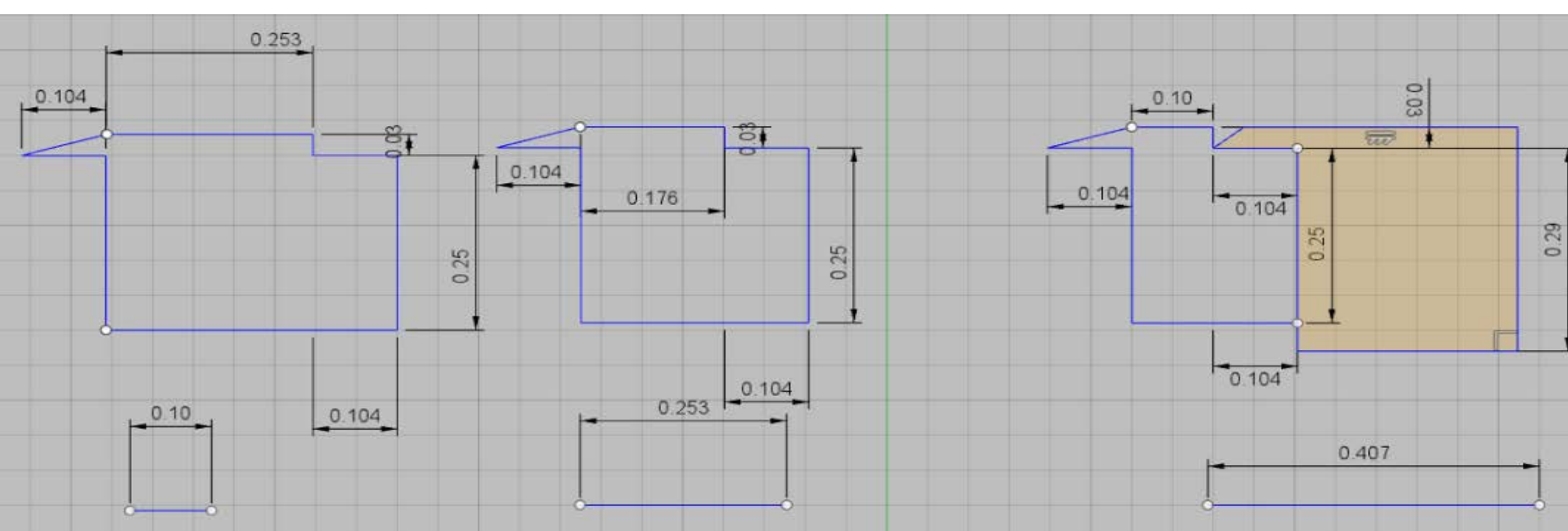

Figure 3: Experiment design for various size chamfered sample holders.

APPROACH

To obtain some estimate of the degree of AO enhancement caused by scattering from the chamfered edges of the sample holders, one can consider that the flux is scattered by being ejected in a cosine or Lambertian manner (just the way light scatters off a matte white surface) from the 45 degree sloped chamfers. Also, similar to light being emitted from a point source, the flux drops off inversely with distance to the sample surface. The flux arriving would be dependent upon the cosine of the angle between the arriving direction and the normal to the sample surface. Using knowledge of the MISSE 2 results for allyl diglycol carbonate (ADC) where the sample mass loss was known and the thickness was just barely eroded through by its perimeter, one can provide a qualitative estimate of the erosion profile as shown in Figure 4 which appears consistent with the MISSE 2 results. This was accomplished using successive iterations of data using Excel.

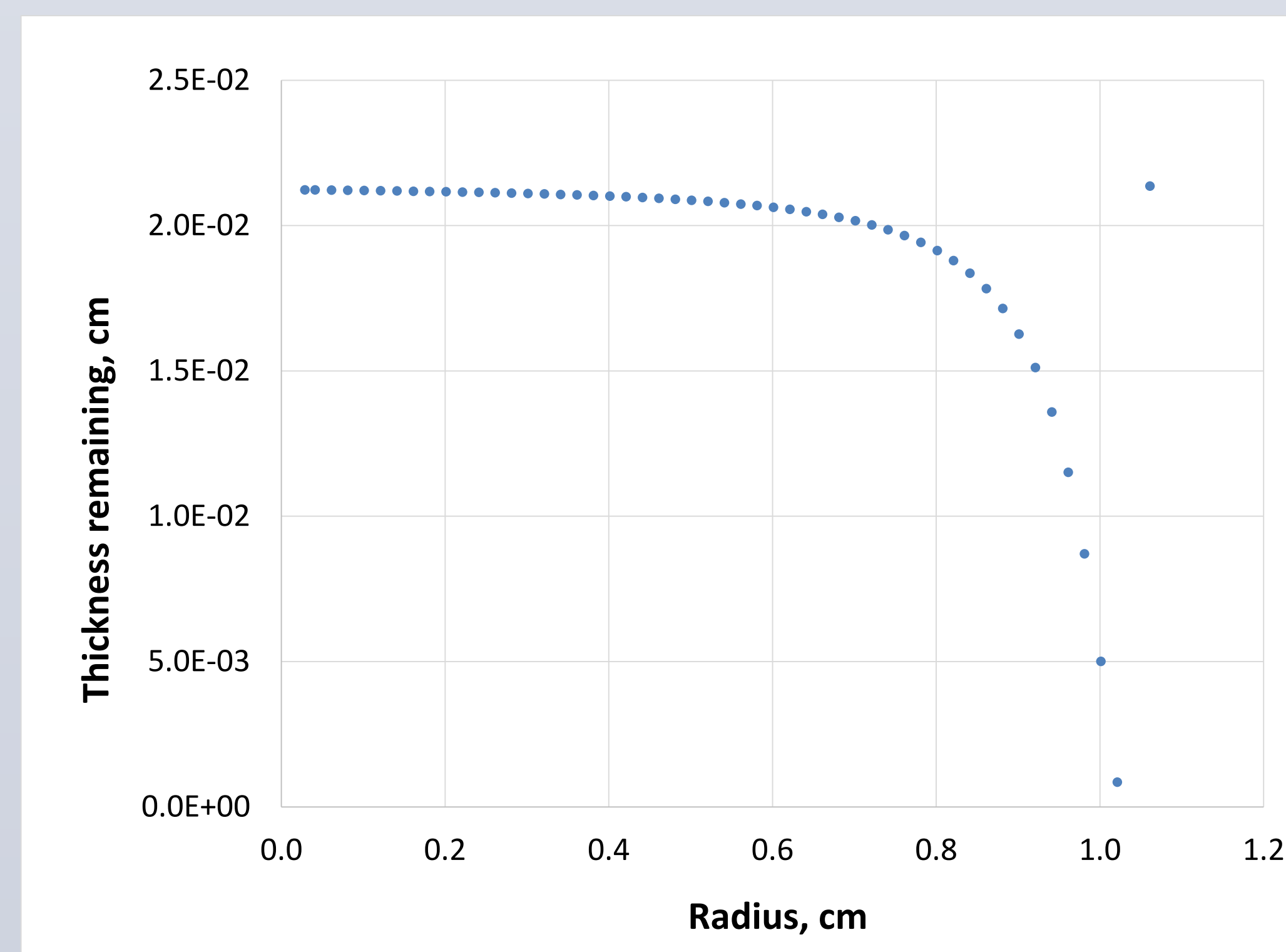

Figure 4: Qualitative model of the eroded profile of ADC from MISSE 2

Materials International Space Station Experiment-Flight Facility (MISSE-FF)

- The new LEO sample holder designs are planned to be flown as part of a future Materials International Space Station Experiment-Flight Facility (MISSE-FF) mission.
- MISSE-FF will be fixed to the exterior of the International Space Station (ISS).
- MISSE-FF will be similar to previous MISSEs as samples will endure extreme levels of atomic oxygen, solar and charged particle radiation, temperature extremes, and hard vacuum with little to no contamination. However, it will be using a new modular design that at any given time allows individual experiments to be added or removed (Ref. 2)
- Samples based on the designed approach have been cut and weighed, and will be flown as part of the MISSE-FF inaugural mission (MISSE-9) in a ram orientation.

The MISSE-9 experiment consists of 4 different diameter chamfered sample holders that have the same geometry chamfers consisting of 0.03 inch thick frame lip with 45 degree chamfered edges for Kapton H and Delrin samples to measure the AO erosion yields. If one assumes the same AO flux impacts the inclined chamfers on the various diameter holders, then a portion of the flux (currently estimated to be 30.4%) will be scattered in a cosine distribution off the chamfers. That portion of the flux which arrives on the samples will add to the flux already arriving from direct ram attack. The flux scattering off the chamfered surfaces will be attenuated by the inverse square of the distance from the chamfer to each point on the samples surface and by the cosine of the angle relative to the surface normal. The result of this scattering is to cause the samples to erode more near their exposed perimeters than would occur if they were infinite in extent. Thus the measured erosion yields from the MISSE 2 sample were higher than their true erosion yields if they were very large samples where chamfering would be a negligible effect. Using this modeling along with actual data from the four different diameter MISSE-9 sample holders, one can predict the actual erosion yield if the samples were very large such as for large thermal control blanket applications on a spacecraft. The plot shows how the expected data can be used to extrapolate what the actual AO erosion yields would be for samples much larger than the flight samples.

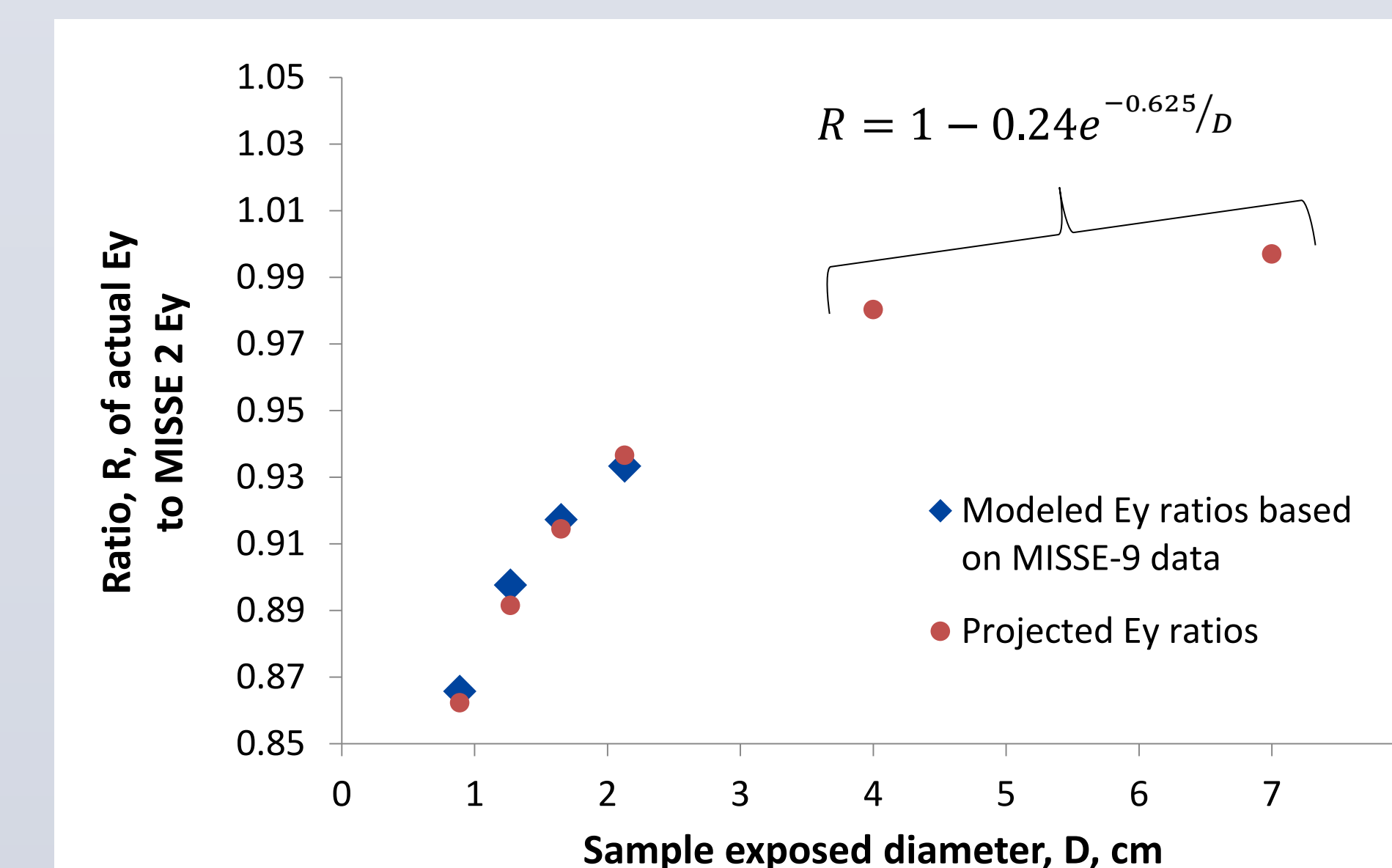

Figure 5: MISSE 9 erosion yield ratios

Using the erosion yields of 4 different exposure diameter samples allows for a quantitative model of the scattering off the chamfered perimeters on the samples such that the planned extrapolation of E_y for large area samples, as shown in Figure 5, should be feasible.

REFERENCES

1. Banks, B. A., de Groh, K. K., Miller, S. K. and Waters, D. L., NASA TM-2008-215264 (July 2008).
2. "About-misse-ff." *About-misse-ff*. N.p., n.d. Web. 01 Mar. 2017.