Physics-of-Failure Approach to Prognostics

Chetan S. Kulkarni

chetan.s.kulkarni@nasa.gov

Agenda

- Introduction to Prognostics
- Introduction to Model-based Prognostics
- Research Approach
- Accelerated Aging as a Prognostics Research Tool
- Case Study I: Prognostics of Electrolytic Capacitors
 - Model-based approach example
- Case Study II: Prognostics of Power Transistors
 - Precursors of Failure example
- Case Study III: Physics-based Prognostics of Capacitors
 - Degradation modeling example
- Case Study IV: Prognostics of Li-Ion Batteries
 - Degradation/Aging example
- Closing Remarks

INTRODUCTION TO PROGNOSTICS

Motivation (1/2)

- Future aircraft systems will rely more on electrical and electronic components
- UAV's with all electric powertrain are increasingly being used for long missions
- Electrical and Electronic components have increasingly critical role in on-board, autonomous functions for
 - Vehicle controls, communications, navigation, radar systems
 - Power electronic devices such as power MOSFETs and IGBTs are frequently used in high-power switching circuits
 - Batteries are the sole energy storage
 - The integrated navigation (INAV) module combines output of the GPS model and inertial measurement unit.
- Assumption of new functionality increases number of faults with perhaps unanticipated fault modes
- We need understanding of behavior of deteriorated components to develop capability to anticipate failures/predict remaining RUL

Motivation (2/2)

Images courtesy : Boeing

**Line Replaceable Unit:
Power Controller**

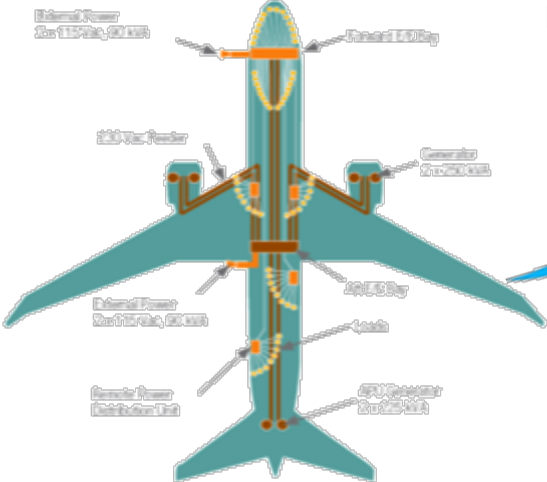

**Component:
Power Transistor**



Definitions

So what is “Prognostics” anyway?

- prog·nos·tic
 - M-W.com – “Something that foretells”
 - PHM Community – “Estimation of the *Remaining Useful Life* of a component”
- Remaining Useful Life (RUL) – The amount of time a component can be expected to continue operating within its stated specifications.
 - Dependent on future operating conditions
 - Input commands
 - Environment
 - Loads

The Basic Idea

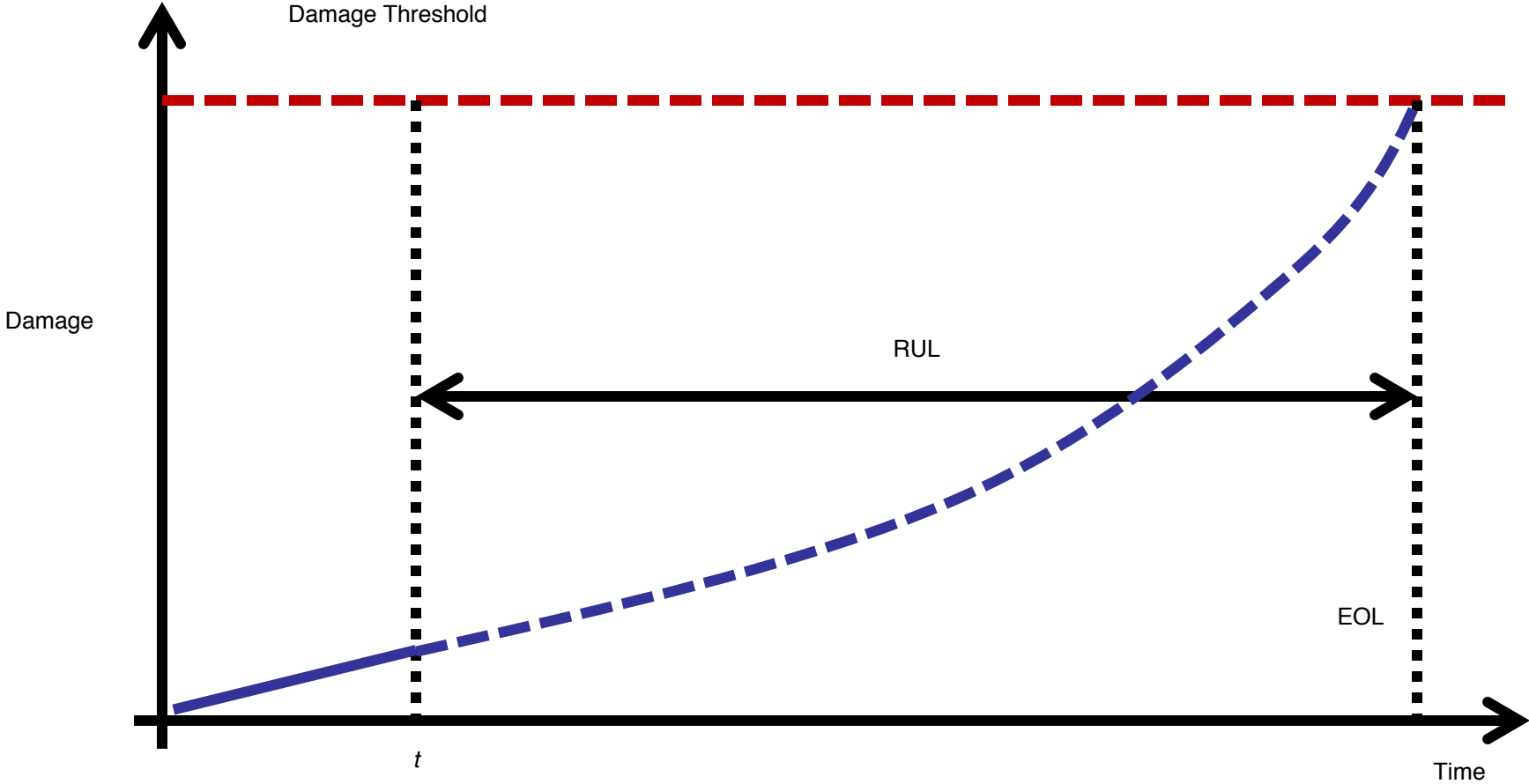

Why Prognostics?

Example: UAV Mission

Visit waypoints to accomplish science objectives. Predict aircraft battery end of discharge to determine which objectives can be met. Based on prediction, plan optimal route. Replan if prediction changes.

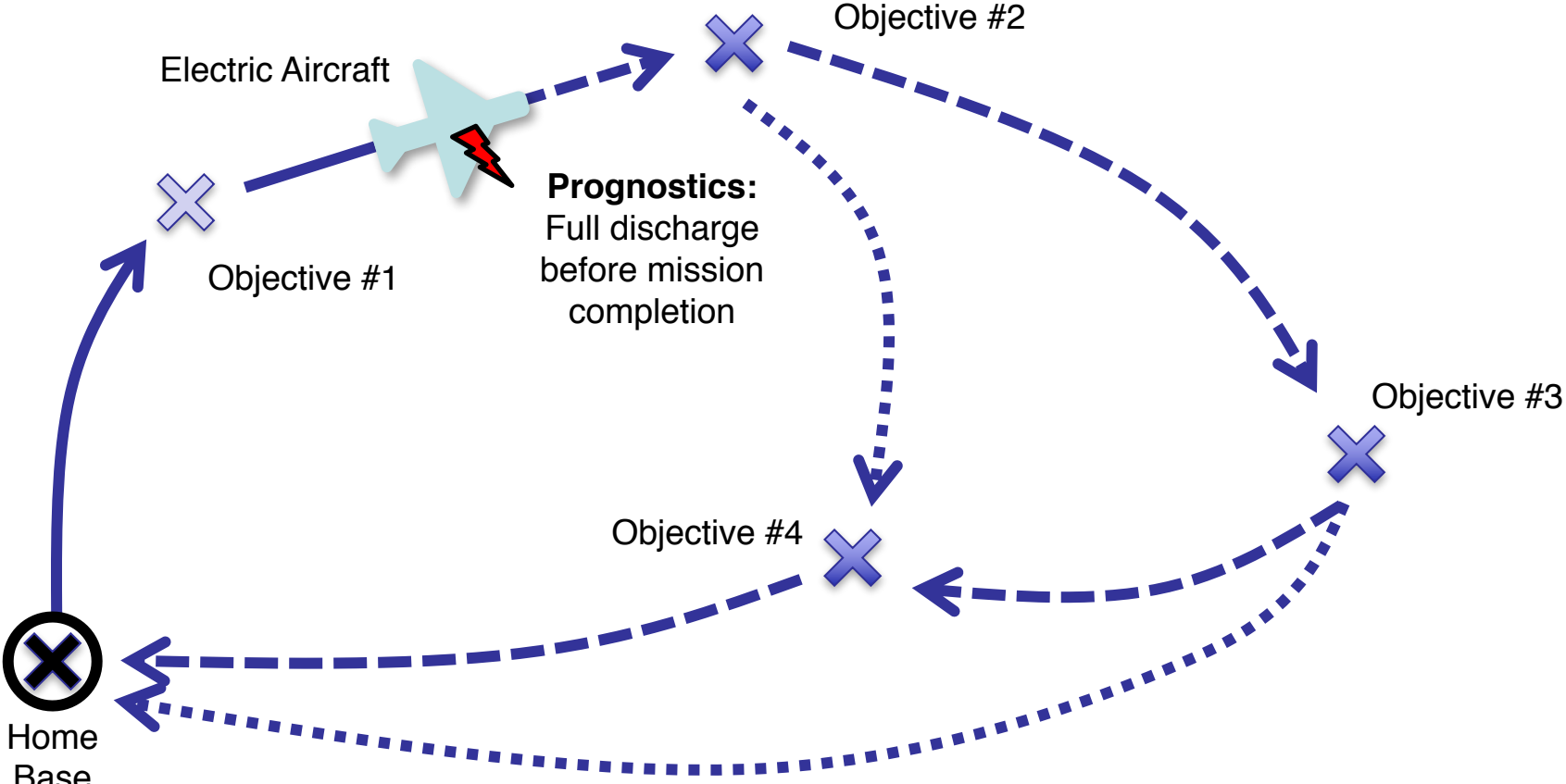

Why Prognostics?

- Prognostics can enable:
 - Adopting condition-based maintenance strategies, instead of time-based maintenance
 - Optimally scheduling maintenance
 - Optimally planning for spare components
 - Reconfiguring the system to avoid using the component before it fails
 - Prolonging component life by modifying how the component is used (e.g., load shedding)
 - Optimally plan or replan a mission
- System operations can be optimized in a variety of ways

The Basic Idea Revisited

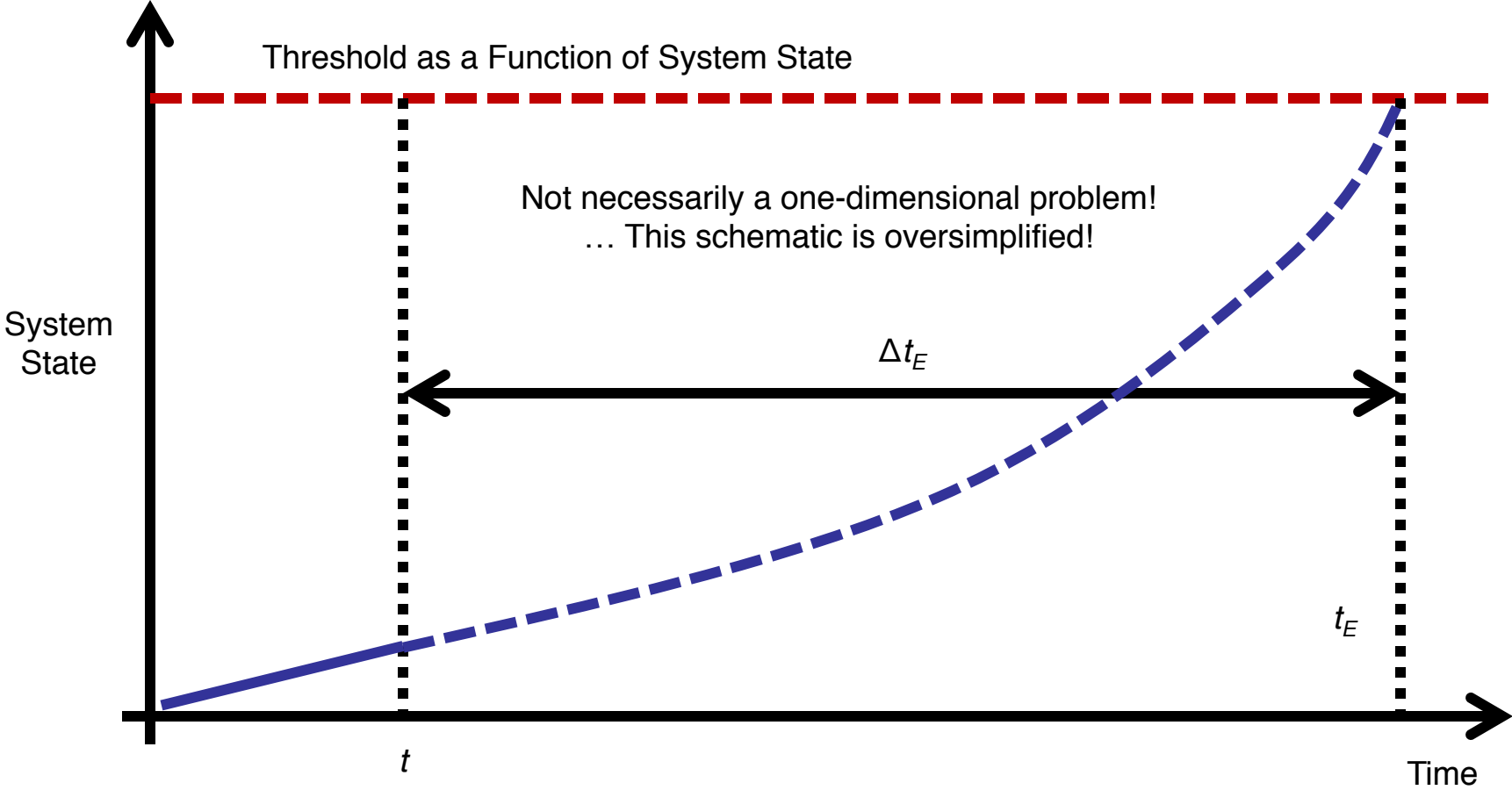

The Basic Idea : Batteries Example

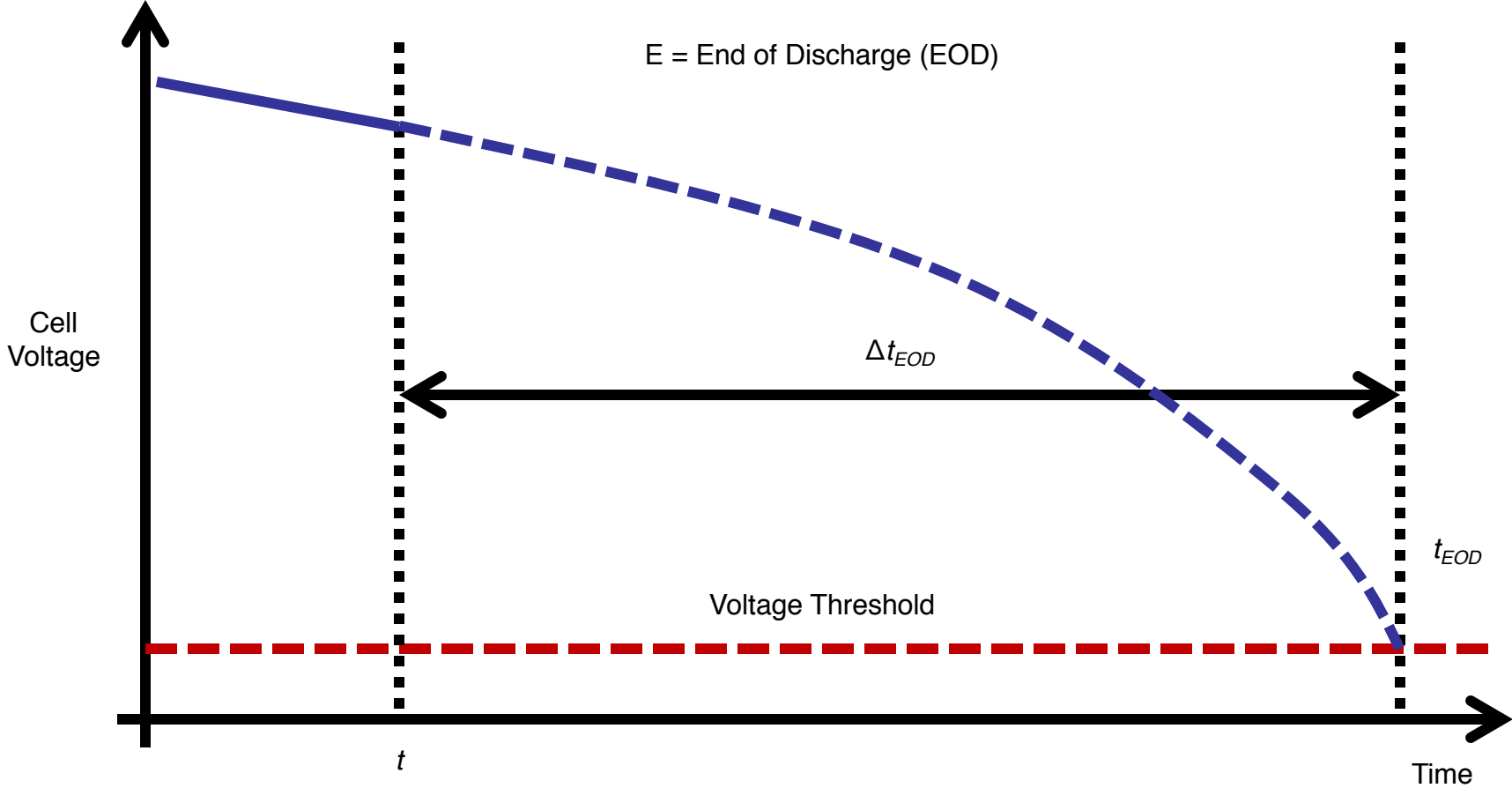

The Basic Idea : Batteries Example

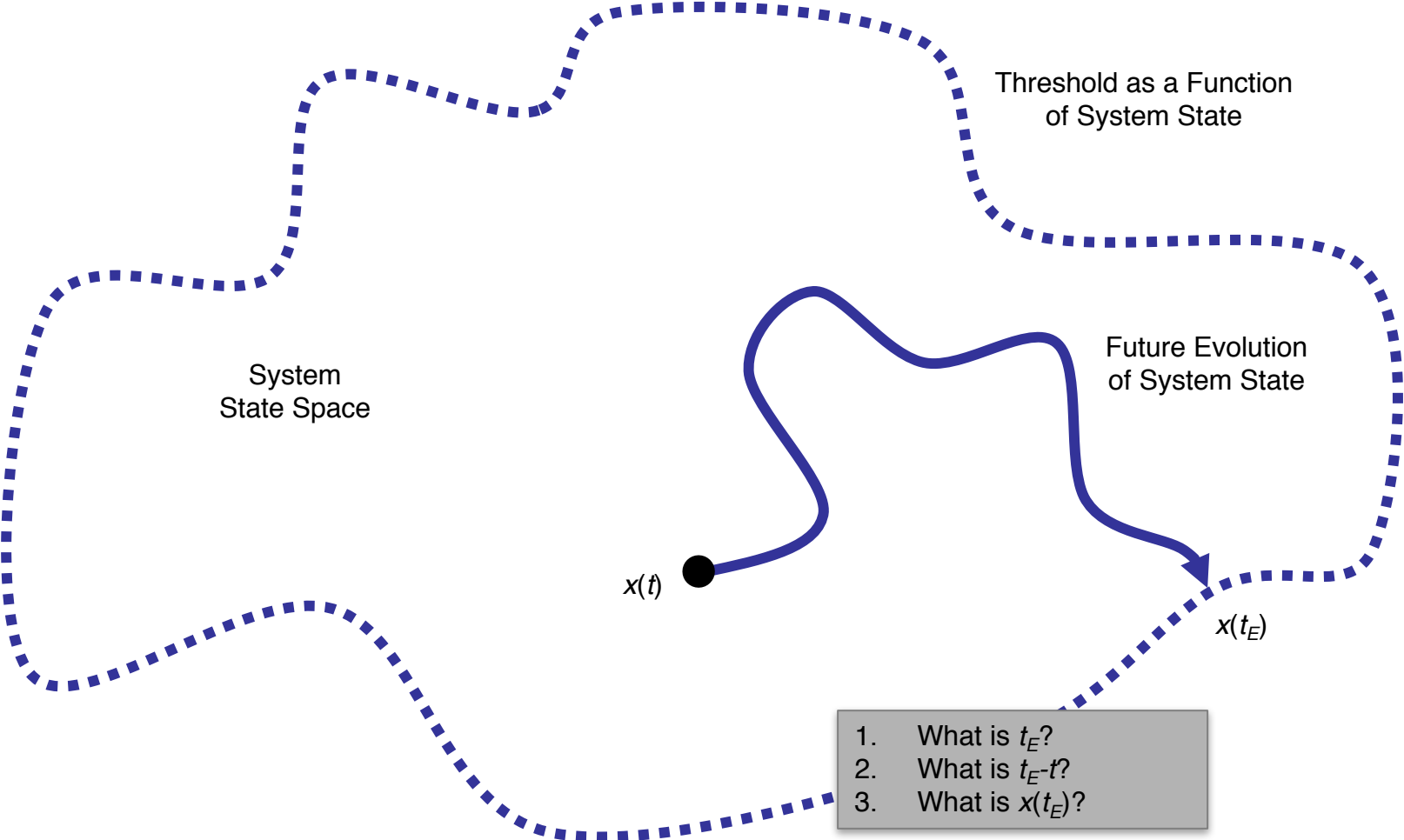

Prognostic Algorithm Categories

- Type I: Reliability Data-based
 - Use population based statistical model
 - These methods consider historical time to failure data which are used to model the failure distribution. They estimate the life of a typical component under nominal usage conditions.
 - Ex: Weibull Analysis
- Type II: Stress-based
 - Use population based fault growth model – learned from accumulated knowledge
 - These methods also consider the environmental stresses (temperature, load, vibration, etc.) on the component. They estimate the life of an average component under specific usage conditions.
 - Ex: Proportional Hazards Model
- Type III: Condition-based
 - Individual component based data-driven model
 - These methods also consider the measured or inferred component degradation. They estimate the life of a specific component under specific usage and degradation conditions.
 - Ex: Cumulative Damage Model, Filtering and State Estimation

Data-Driven Methods

- Model is based solely on data collected from the system
- Some system knowledge may still be handy:
 - What the system ‘is’
 - What the failure modes are
 - What sensor information is available
 - Which sensors may contain indicators of fault progression (and how those signals may ‘grow’)
- *General steps:*
 - Gather what information you can (if any)
 - Determine which sensors give good trends
 - Process the data to “clean it up” – try to get nice, monotonic trends
 - Determine threshold(s) either from experience (data) or requirements
 - Use the model to predict RUL
 - Regression / trending
 - Mapping (e.g., using a neural network)
 - Statistics

Data-Driven Methods

- Pros
 - Easy and Fast to implement
 - Several off-the-shelf packages are available for data mining
 - May identify relationships that were not previously considered
 - Can consider all relationships without prejudice
- Cons
 - Requires lots of data and a “balanced” approach
 - Most of the time, lots of run-to-failure data are not available
 - High risk of “over-learning” the data
 - Conversely, there’s also a risk of “over-generalizing”
 - Results may be counter- (or even un-)intuitive
 - Correlation does not always imply causality!
 - Can be computationally intensive, both for analysis and implementation
- Example techniques
 - Regression analysis
 - Neural Networks (NN)
 - Bayesian updates
 - Relevance vector machines (RVM)

Physics-Based Methods

- Description of a system's underlying physics using suitable representation
- Some examples:
 - Model derived from “First Principles”
 - Encapsulate fundamental laws of physics
 - PDEs
 - Euler-Lagrange Equations
 - Empirical model chosen based on an understanding of the dynamics of a system
 - Lumped Parameter Model
 - Classical 1st (or higher) order response curves
 - Mappings of stressors onto damage accumulation
 - Finite Element Model
 - High-fidelity Simulation Model
- Something in the model correlates to the failure mode(s) of interest

Physics-Based Models

- Pros
 - Results tend to be intuitive
 - Based on modeled phenomenon
 - And when they're not, they're still instructive (e.g., identifying needs for more fidelity or unmodeled effects)
 - Models can be reused
 - Tuning of parameters can be used to account for differences in design
 - If incorporated early enough in the design process, can drive sensor requirements (adding or removing)
 - Computationally efficient to implement
- Cons
 - Model development requires a thorough understanding of the system
 - High-fidelity models can be computationally intensive
- Examples
 - Paris-Erdogan Crack Growth Model
 - Taylor tool wear model
 - Corrosion model
 - Abrasion model

INTRODUCTION TO MODEL- BASED PROGNOSTICS

Model-based prognostics (1/2)

$$\dot{\mathbf{x}}(t) = f(\mathbf{x}(t), u(t)) + w(t)$$
$$y(t) = h(\mathbf{x}(t), u(t)) + v(k)$$

$$R(t_p) = t_{EOL} - t_p$$

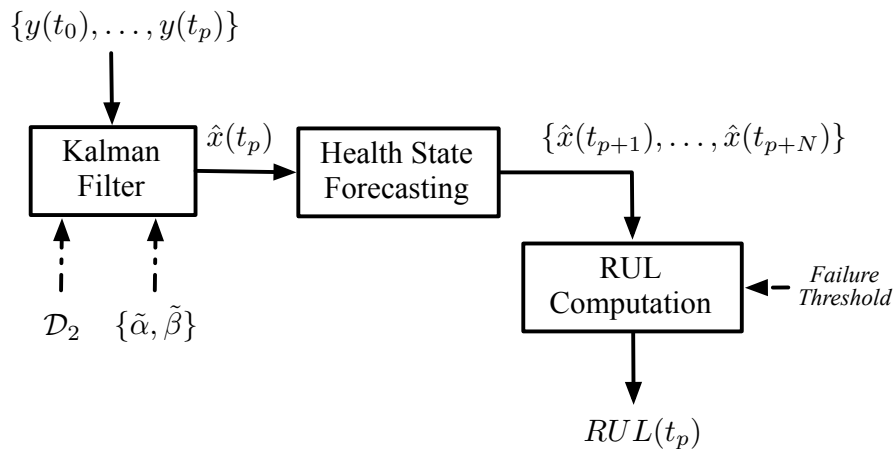

- State vector includes dynamics of the degradation process
- It might include nominal operation dynamics
- EOL defined at time in which performance variable cross failure threshold
- Failure threshold could be crisp or also a random variable

Model-based prognostics (2/2)

- Tracking of health state based on measurements
- Forecasting of health state until failure threshold is crossed
- Compute RUL as function of EOL defined at time failure threshold is crossed

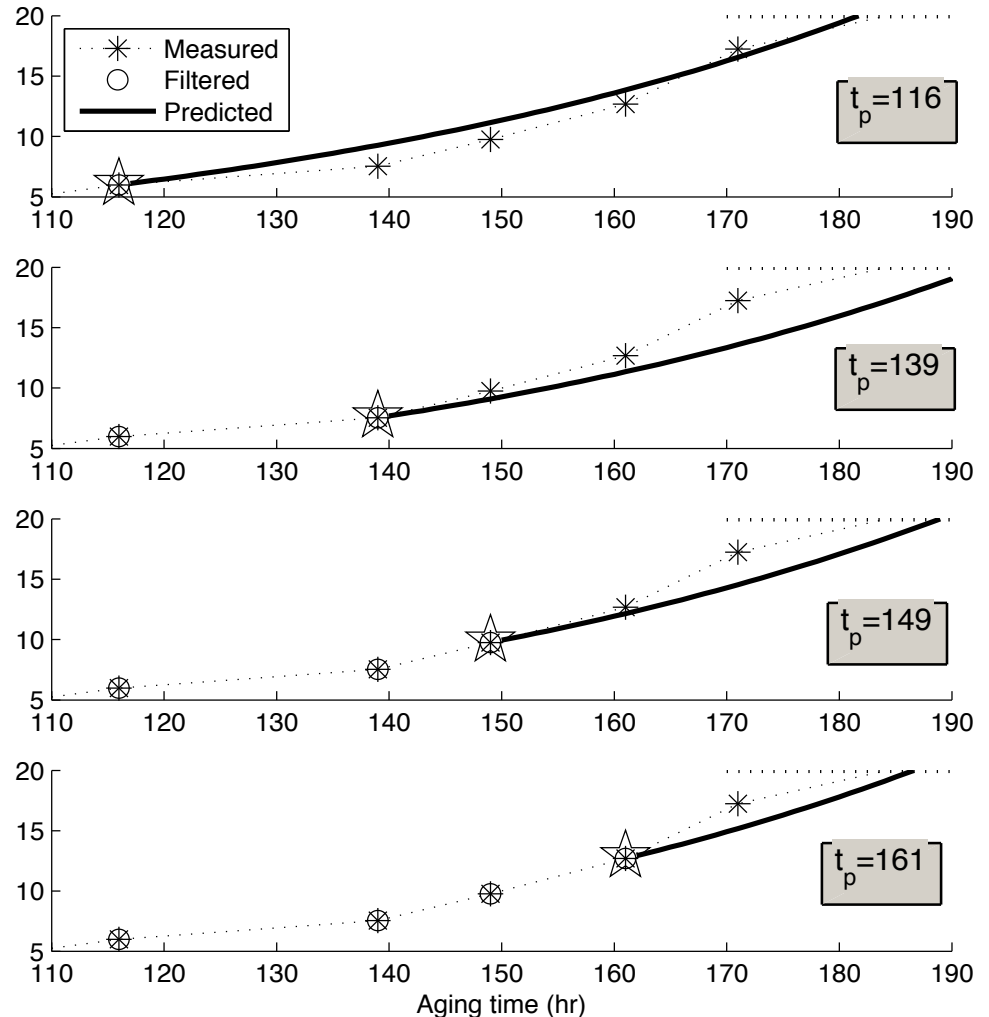

Methodology

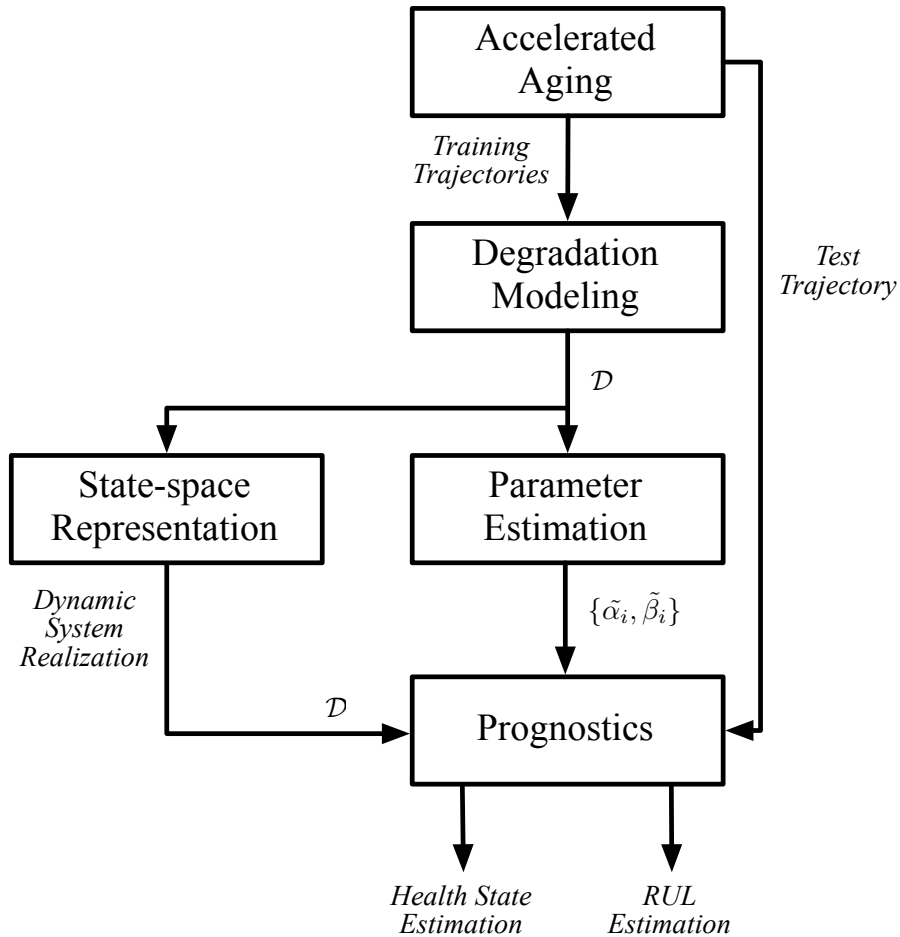

$$x_k = Ax_{k-1} + Bu_{k-1} + w_{k-1}$$

$$y_k = Hx_k + v_k$$

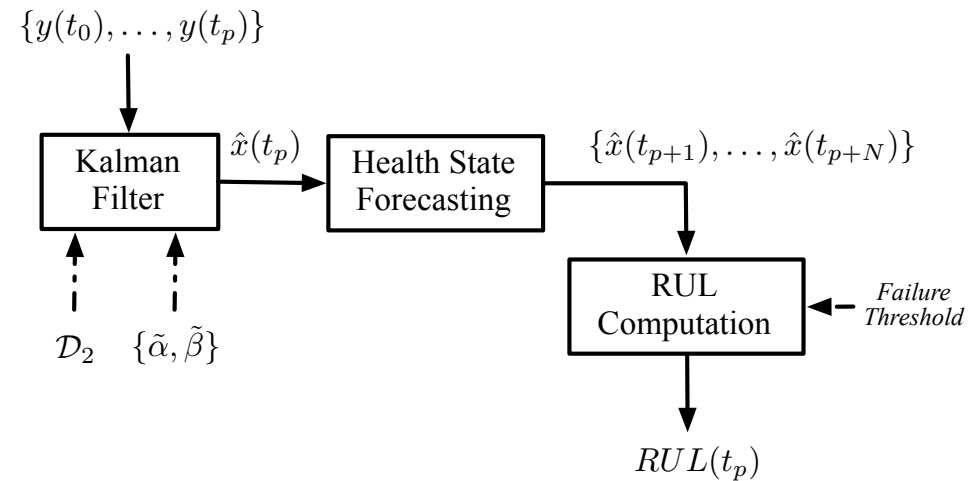

RESEARCH APPROACH

High level research efforts

- **Prognostics models and algorithms**
 - Identification of precursors of failure for MOSFETs under different failure mechanism conditions
 - Identification of precursors of failure for different IGBT technologies
 - Modeling of degradation process MOSFETs
 - Development of prognostics algorithms
- **Prognostics for output capacitor in power supplies (ARC)**
 - Electrical overstress and thermal overstress
 - Development of prognostics algorithms
- **Accelerated Life Testing**
 - Thermal overstress aging of MOSFETs and IGBTs
 - Electrical overstress aging testbed MOSFETs
 - Electrical overstress aging testbed for Capacitors
- **Effects of lightning events of MOSFETS (LaRC)**
- **Battery Degradation and ageing (ARC – LaRC)**
- **Ageing Effecting on ESC's (ARC – LaRC)**

Research Approach

Identification of failure modes and their relationship to their particular failure mechanisms



Identification of precursors of failure which play an essential role in the prediction of remaining life



Development of accelerated aging testbeds that facilitate the exploration of different failure mechanisms and aid the understanding of damage progression



Development of degradation models based on the physics of the device and the failure mechanisms



Development of remaining life prediction algorithms that take into account the different sources of uncertainty while leveraging physics-based degradation models that considers future operational and environmental conditions

Prognostics Algorithm Maturation through Validation Experiments

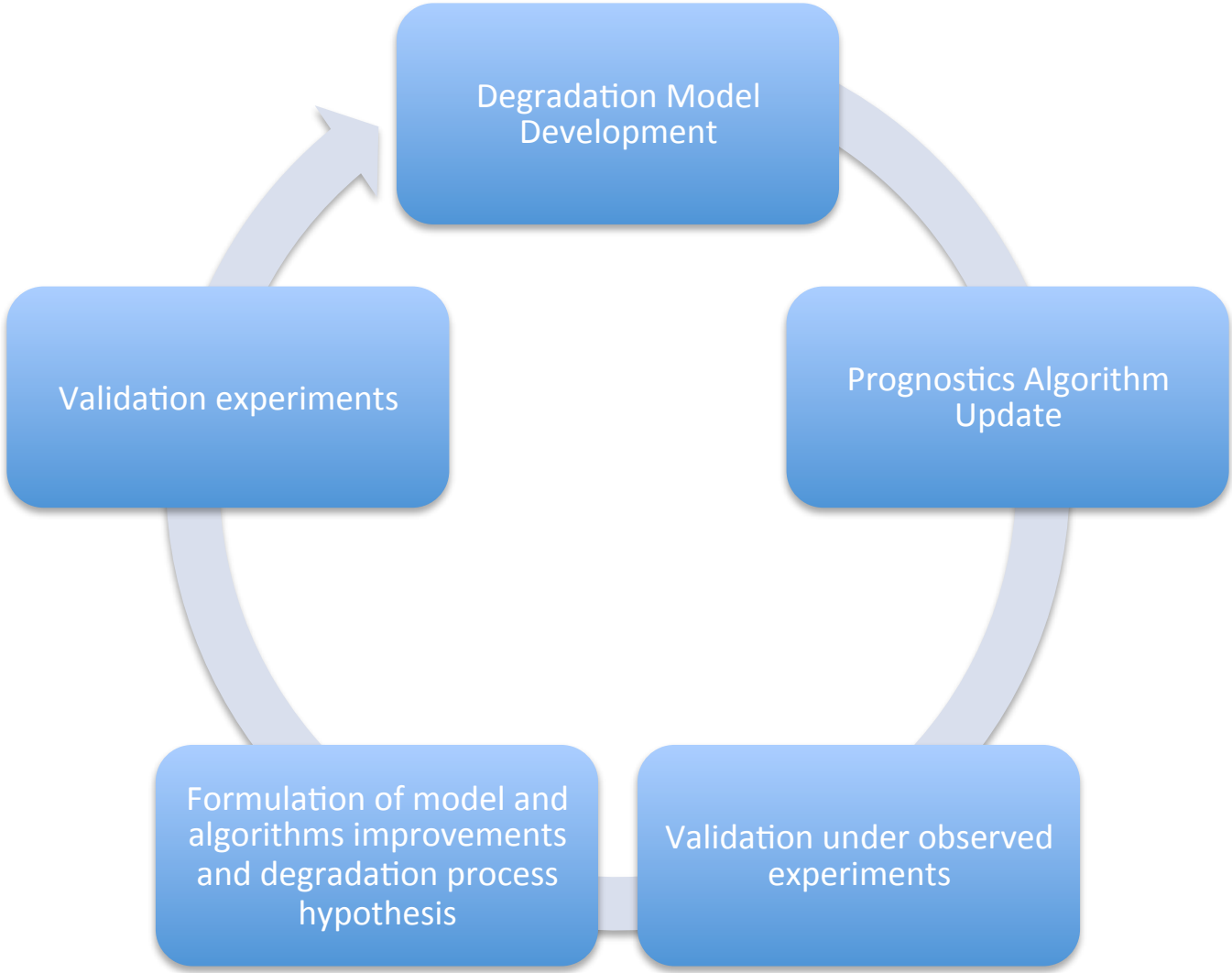

Prognostics Algorithm Maturation through Validation Experiments

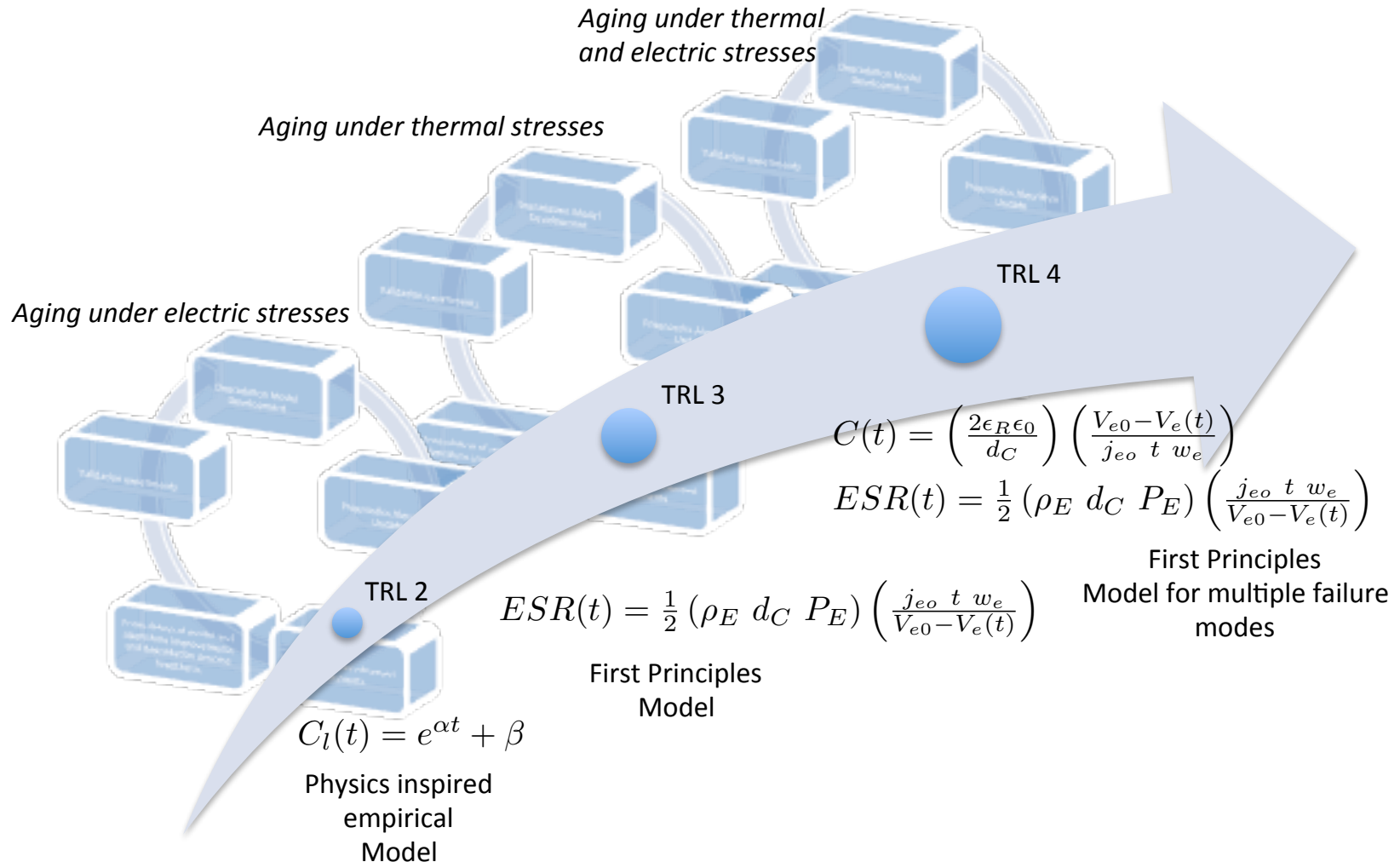

ACCELERATED AGING AS A PROGNOSTICS RESEARCH TOOL

Accelerated Aging

- **Traditionally used to assess the reliability of products** with expected lifetimes in the order of thousands of hours
 - in a considerably shorter amount of time
- Provides opportunities for the development and validation of prognostic algorithms
- Such experiments are invaluable since **run-to-failure data for prognostics is rarely or never available**
- Unlike reliability studies, prognostics is concerned not only with time to failure of devices but with the degradation process leading to an irreversible failure
 - This **requires in-situ measurements** of key output variables and observable parameters in the accelerated aging process with the associated time information
- Thermal, electrical and mechanical overstresses are commonly used for accelerated aging tests of electronics

Example: Electrical overstress aging of Power Transistors

Accelerate aging strategy (1/3)

- The main strategy is the
 - application of electrical overstress
 - fixed junction temperature in order to avoid thermal cycles
 - avoid package related failures
- Accelerated test conditions are achieved by electrical operation regime of the devices at temperatures within the range below maximum ratings and above the room temperatures.

Accelerate aging strategy (2/2)

- The highest acceleration factor for aging can be achieved in the proximity of the SOA boundary
- Instability points represent the critical voltages and currents limiting the SOA
- An electrical regime close to the SOA boundary serves as the accelerator factor (stressor) and it is expected to reduce the life of the device
- The safe operation area boundary shifts closer to the origin as the temperature increases

Simulated I-V characteristics and instability boundary at 300° K for power MOSFET.

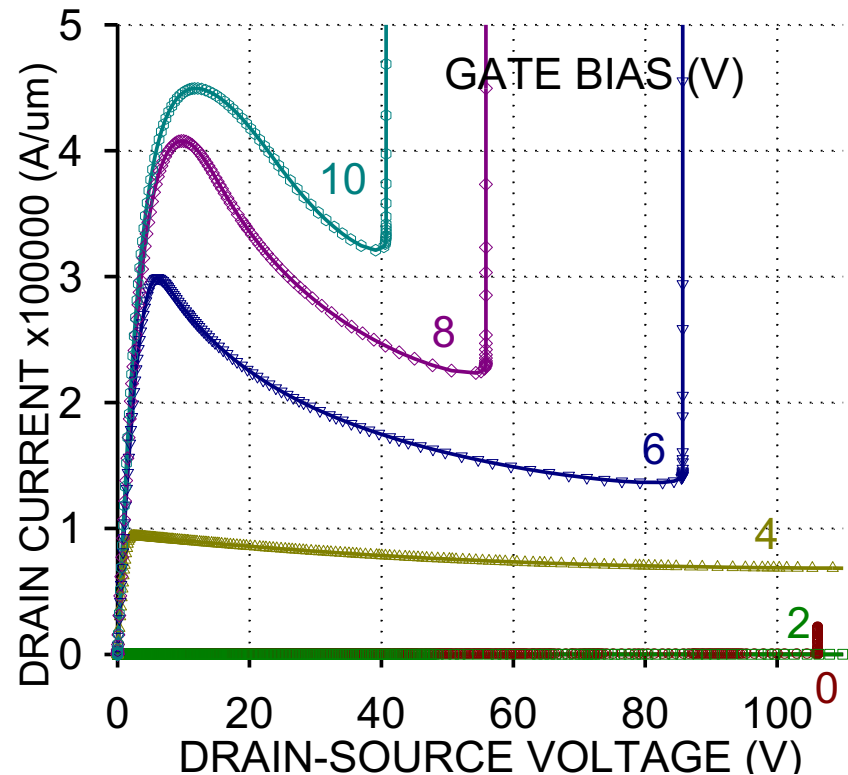

Aging system description (1/3)

- Three main components in terms of hardware
 - Electrical operation unit of the device
 - custom made printed circuit boards for the instrumentation circuitry and gate drivers
 - commercially available power supplies and function generator to control the operation of the DUT
 - An in-situ measurement unit of key electrical and thermal parameters
 - commercially available measurement and data acquisition for slow and high speed measurements
 - Thermal block section for monitoring and control of the temperature

Aging system description (2/3)

Thermal block for measurement and control of device temperature

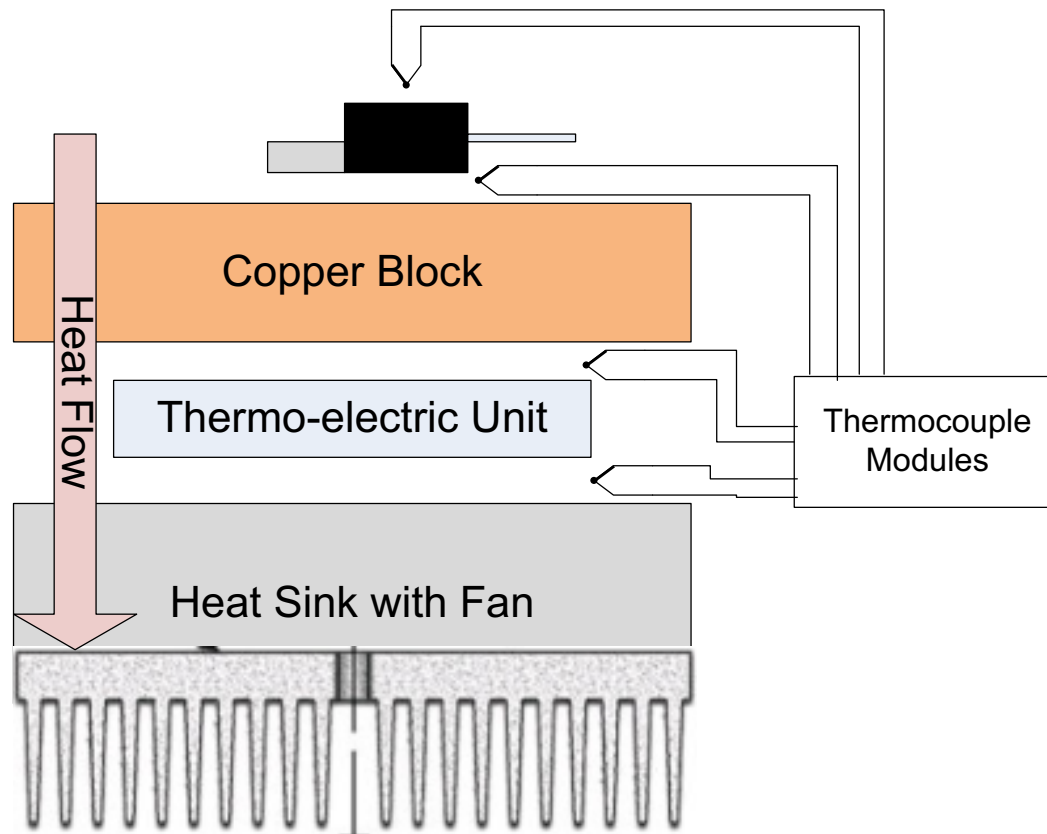

Aging system description (3/3)

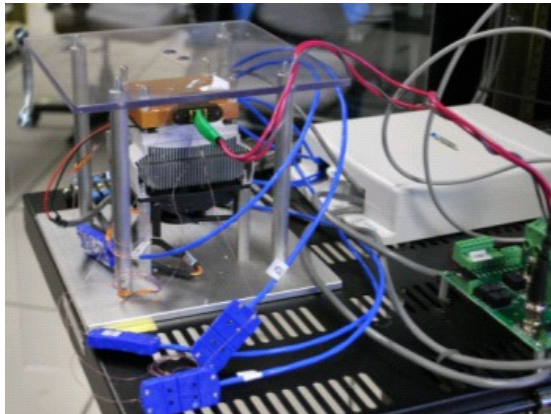
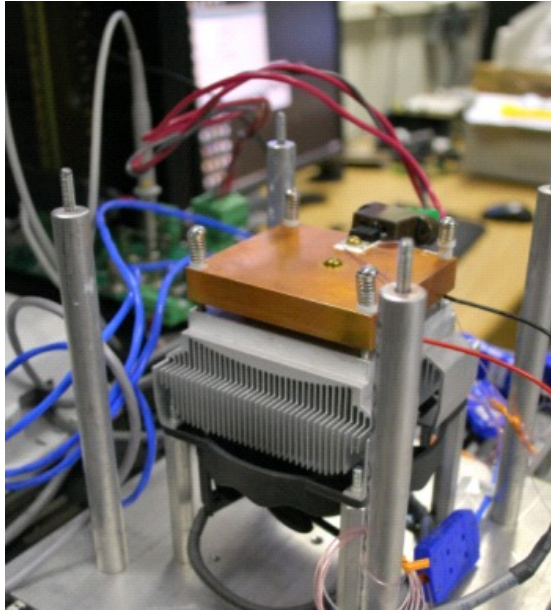

Experiment on power MOSFET (1/2)

- IRF520Npbf power MOSFET
 - TO220 package, 100V/9A.
- Electrical overstress used as acceleration factor.
High potential at the gate
 - $V_{gs}=50V$, V_{gs} rating is 20V max.
 - $V_{ds}=2.4V$ with a 0.2 ohm load.
- Temperatures kept below maximum rating
 $T_{j,max}=175^{\circ} C$
- Objective is to induce failure mechanism on the gate structure

Experiment on power MOSFET (2/2)

- Degradation process as observed on threshold voltage (V_{th})

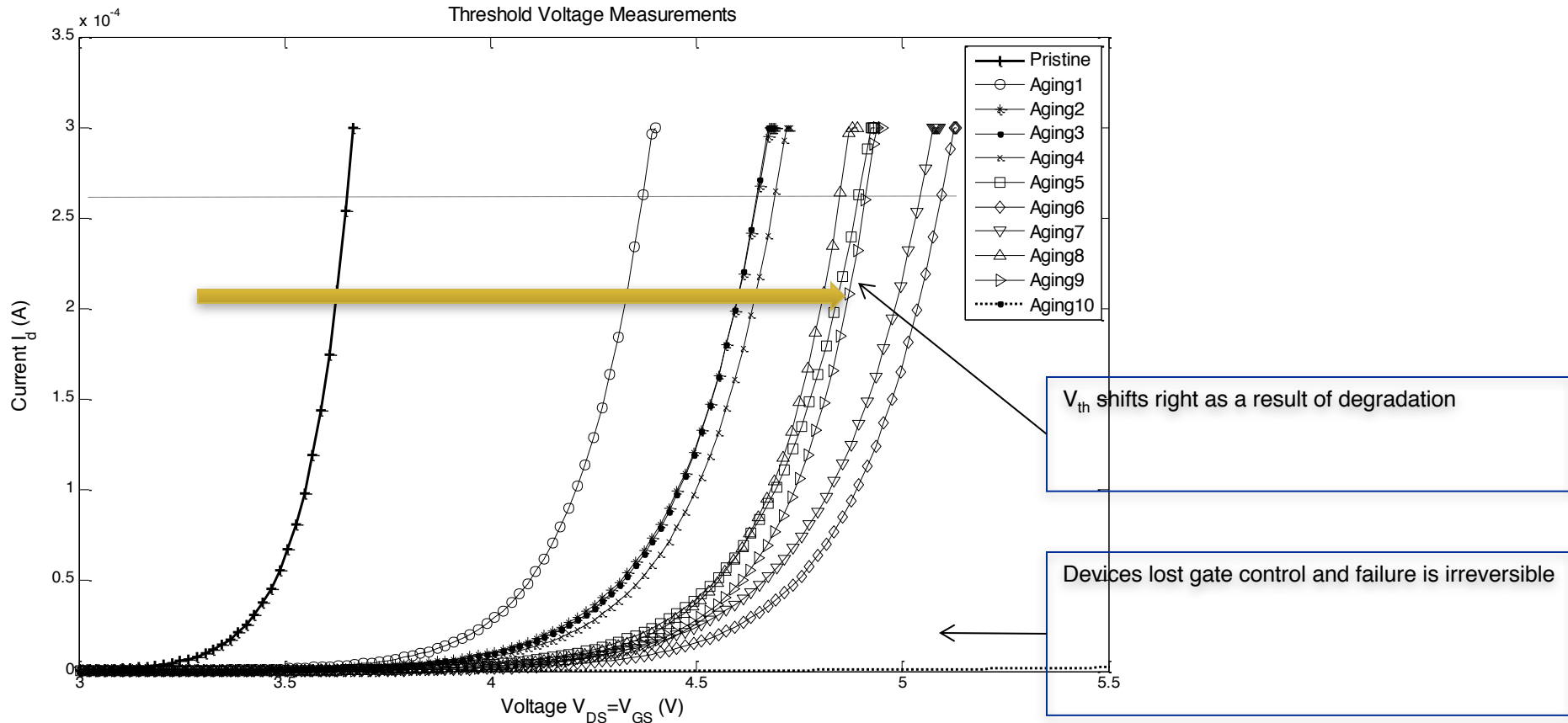

Example: Electrical overstress aging of Electrolytic Capacitors

Accelerated aging system

- Allows for the understanding of the effects of failure mechanisms, and the identification of leading indicators of failure essential for the development of physics-based degradation models and RUL prediction
- Electrolytic capacitor 2200 μ F, 10V and 1A
- Electrical overstress >200 hr
 - Square signal at 200 mHz with 12V amplitude and 100 ohm load

Electrical Overstress Aging System

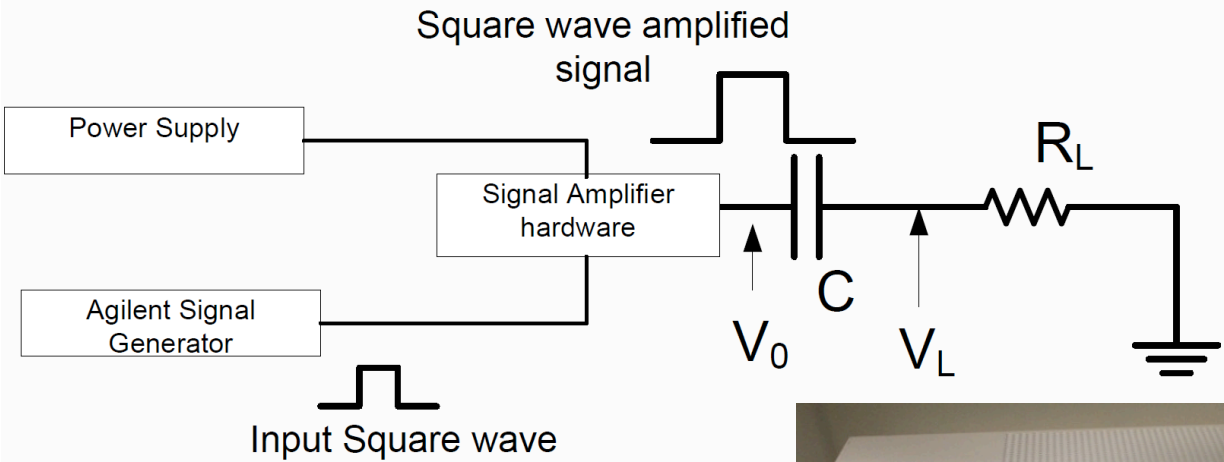

Degradation observed on EIS measurements

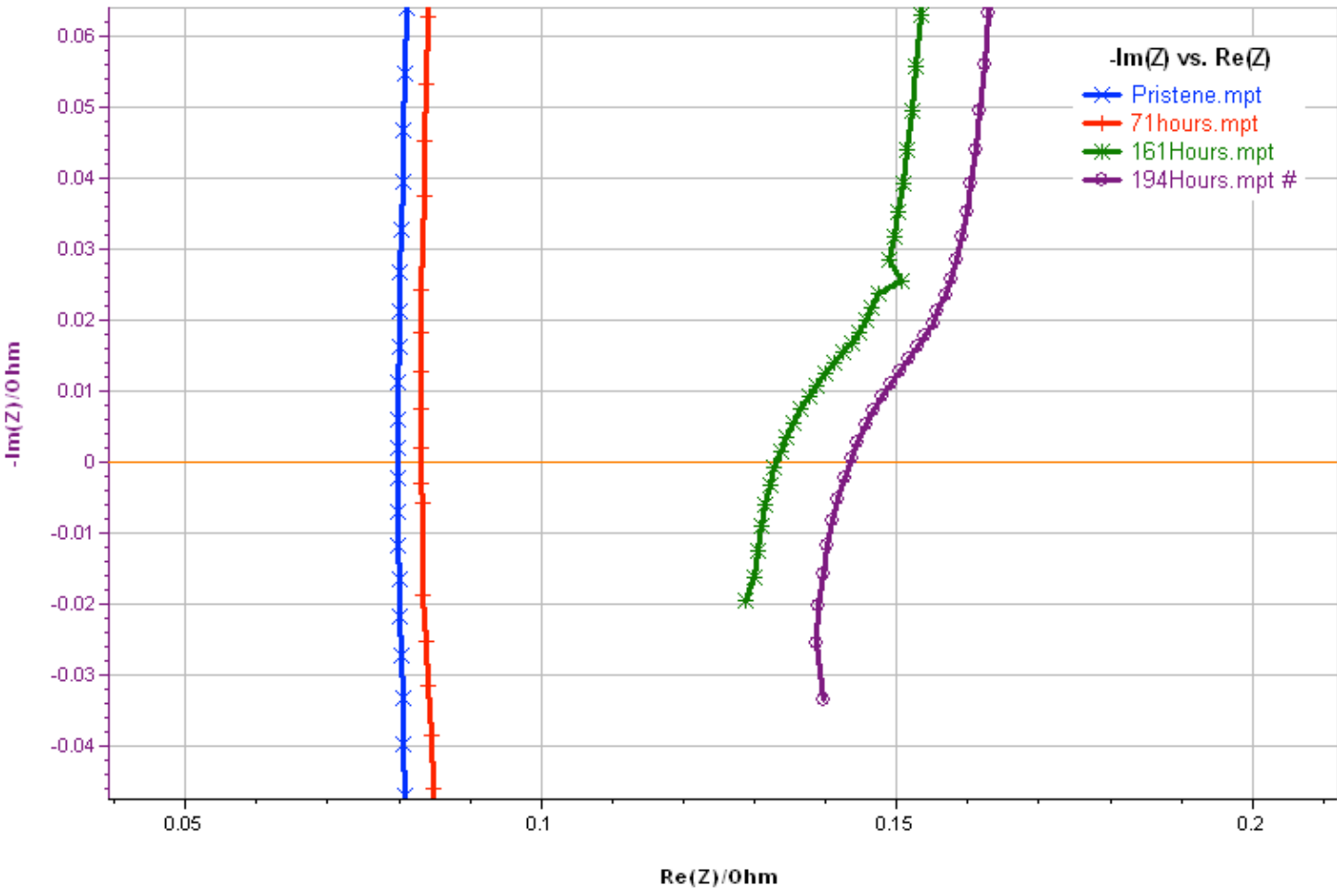

**CASE STUDY I:
PROGNOSTICS OF
ELECTROLYTIC CAPACITORS**
MODEL-BASED APPROACH EXAMPLE

Case Study: Avionics System

- Integrated Avionics systems consists of:
 - Global Positioning System (GPS) module
 - Integrated navigation (INAV) module combines output of the GPS model and Inertial measurement unit
 - Power Supply module

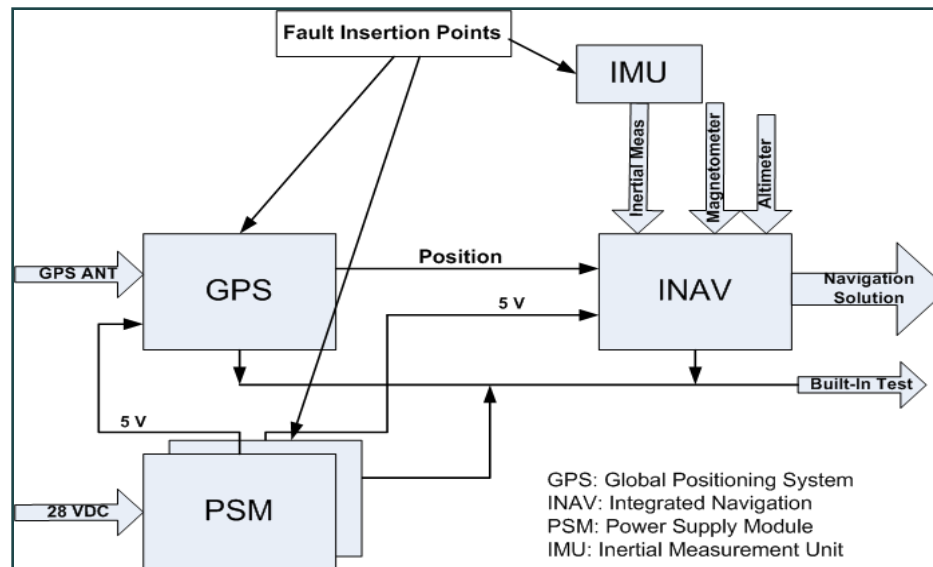

Methodology

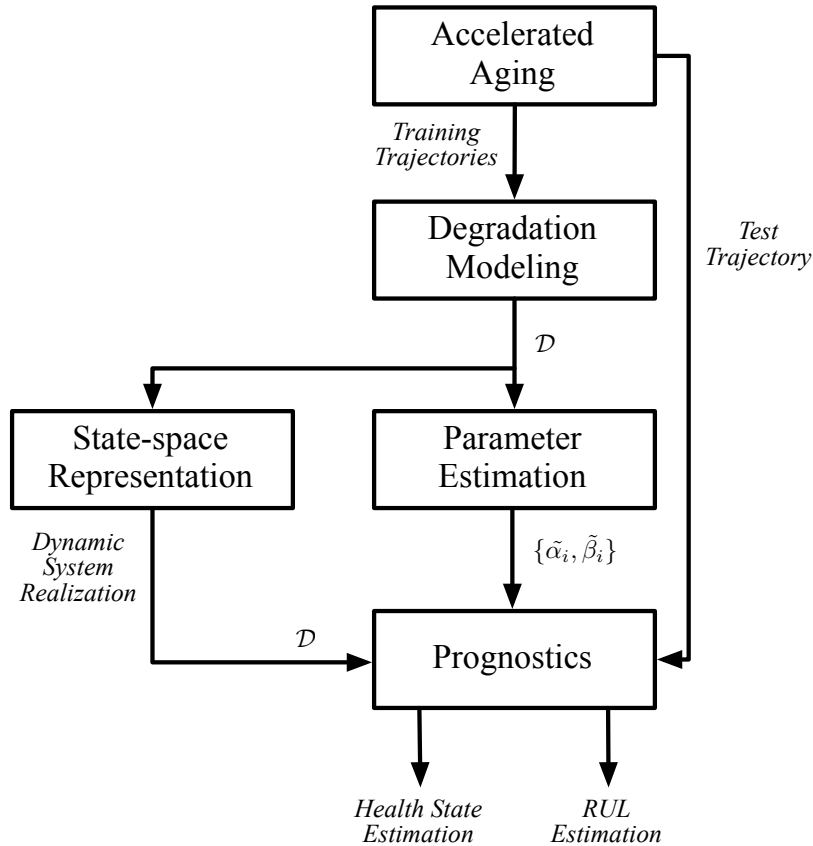

$$x_k = Ax_{k-1} + Bu_{k-1} + w_{k-1}$$

$$y_k = Hx_k + v_k$$

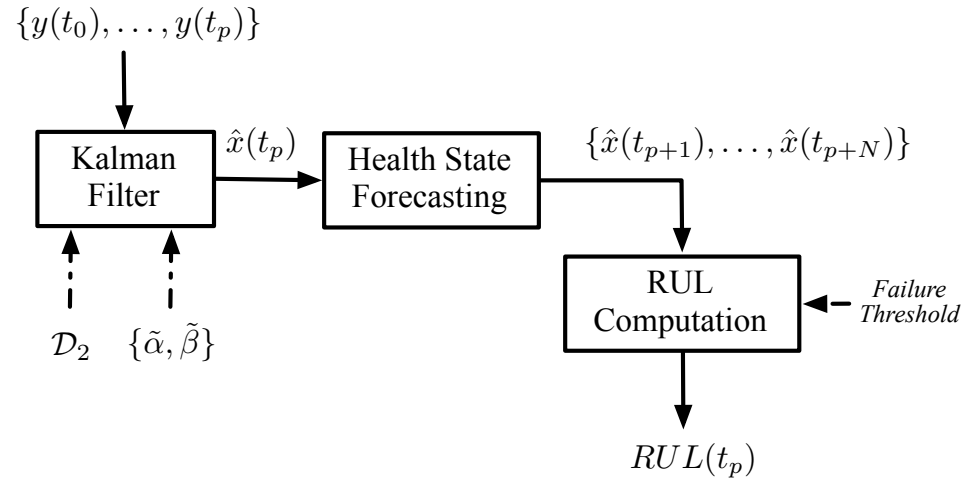

Accelerated Aging and Precursors of Failure Features

Degradation on lumped parameter model

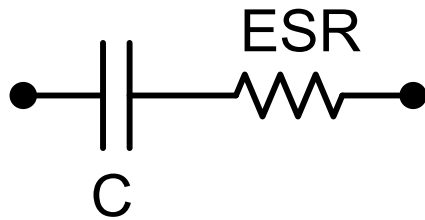

C and ESR are estimated from EIS measurements

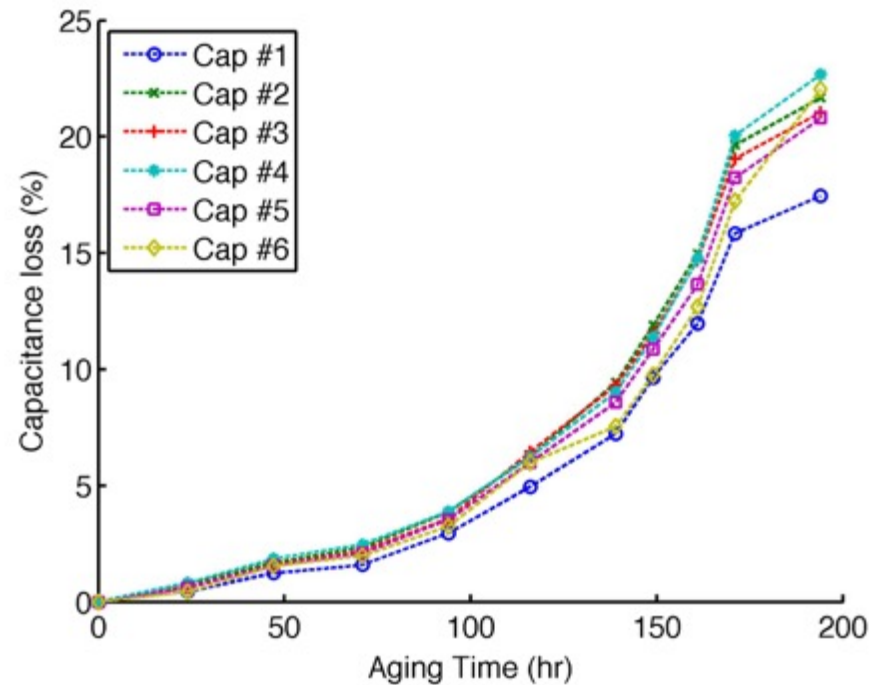
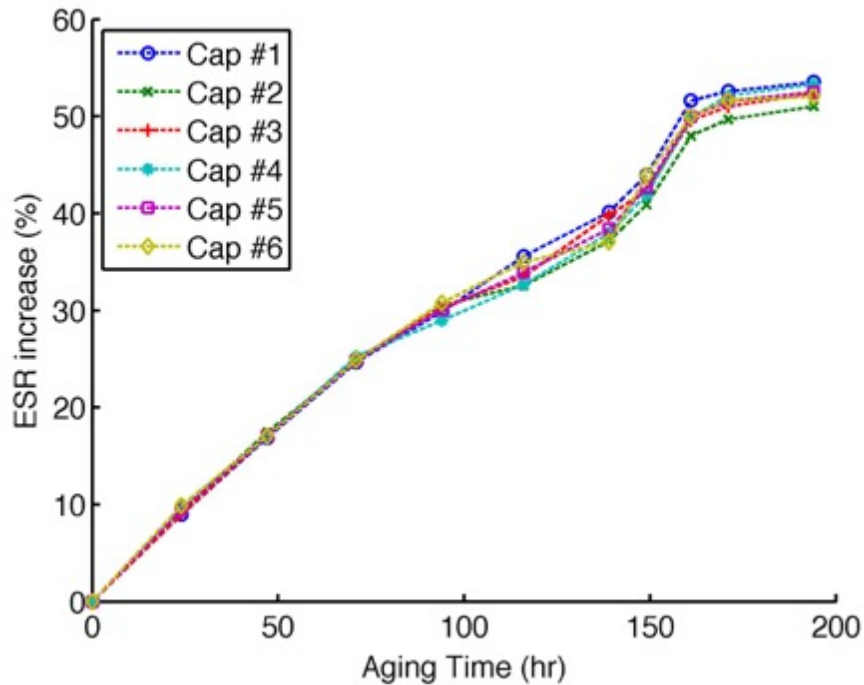

Methodology

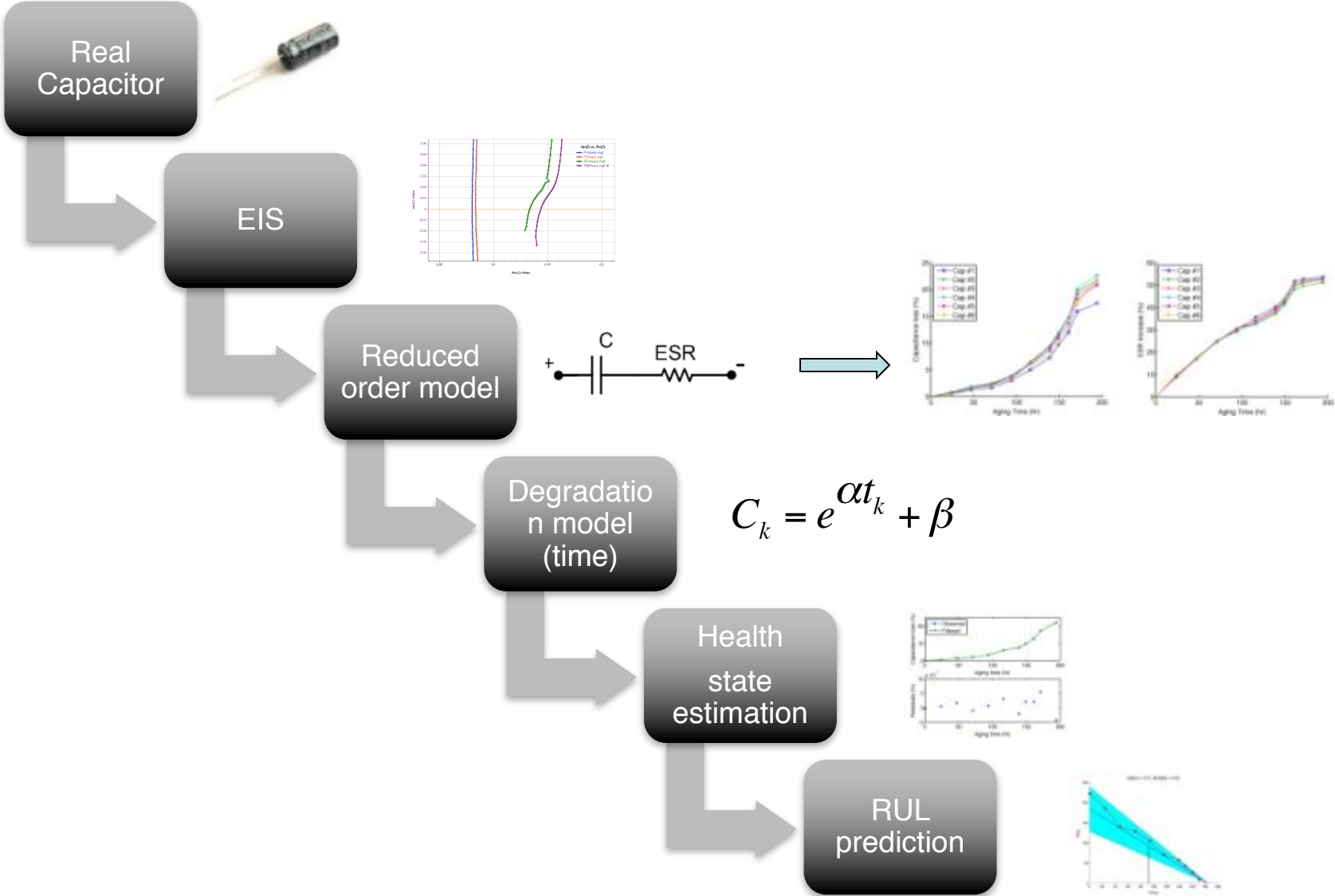

CASE STUDY II: PROGNOSTICS OF POWER TRANSISTORS

PRECURSORS OF FAILURE EXAMPLE

Modeling for Power MOSFET under electrical overstress

- Two-transistor model is shown to be a good candidate for a degradation model for model-based prognostics.
- The model parameters K , and $W1$ could be varied as the device degrades as a function of usage time, loading and environmental conditions.
- Parameter $W1$ defines the area of the healthy transistors, the lower this area, the larger the degradation in the two-transistor model. In addition, parameter K serves as a scaling factor for the thermal resistance of the degraded transistors, the larger this factor, the larger the degradation in the model.

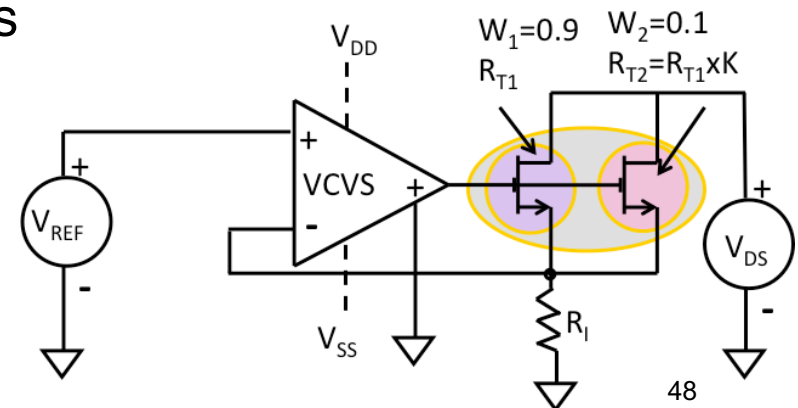
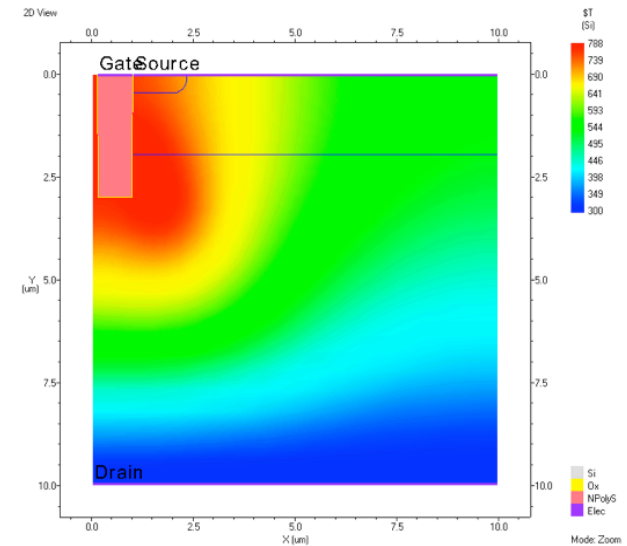

Precursor of Failure

- As case temperature increases, ON-resistance increases
- This relationship shifts as the degradation of the device increases
- For a degraded state, ON-resistance will be higher at any given case temperature
- This is consistent with the die-attach damage since it results on increased junction temperature operation
- This plot can be used directly for fault detection and diagnostics of the die-attach failure mechanism

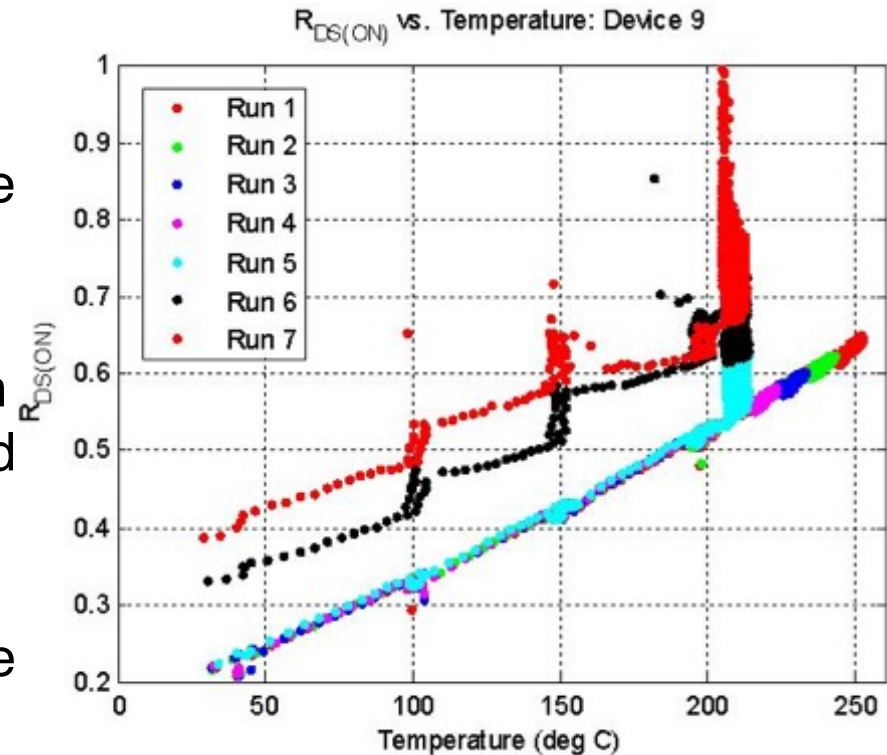

Prediction of Remaining Life

RUL Prediction Methodology Considerations

- A single feature is used to assess the health state of the device ($\Delta R_{DS(ON)}$)
- It is assumed that the die-attached failure mechanism is the only active degradation during the accelerated aging experiment
- Furthermore, $\Delta R_{DS(ON)}$ accounts for the degradation progression from nominal condition through failure
- Periodic measurements with fixed sampling rate are available for $\Delta R_{DS(ON)}$
- A crisp failure threshold of 0.05 increase in $\Delta R_{DS(ON)}$ is used
- The prognostics algorithm will make a prediction of the remaining useful life at time t_p , using all the measurements up to this point either to estimate the health state at time t_p in a regression framework or in a Bayesian state tracking framework
- It is also assumed that the future load conditions do not vary significantly from past load conditions

RUL Prediction Algorithms

- Gaussian Process Regression
 - Algorithm development cases used to select covariance matrix structure and values
- Extended Kalman filter
 - Empirical degradation model
 - State variable: Normalized ON-resistance and degradation model parameters
 - Arbitrary values for measurement and process noise variance
- Particle filter
 - Empirical degradation model
 - State variable: Normalized ON-resistance, degradation model parameters
 - Exponential growth model used for degradation model parameters
 - Arbitrary values for measurement and process noise variance

RUL estimation results

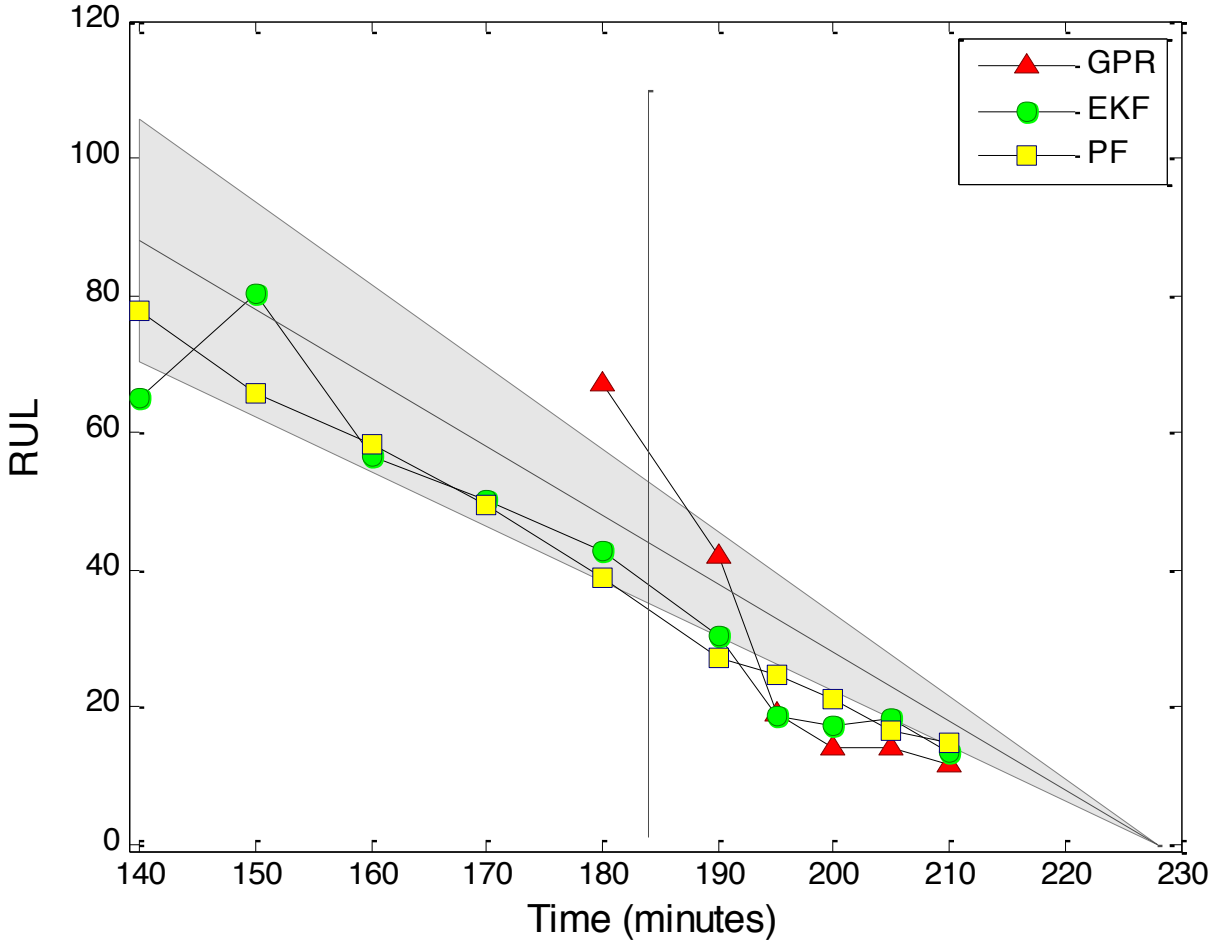

End of Case Study II:

QUESTIONS?

CASE STUDY III: PHYSICS- BASED PROGNOSTICS OF CAPACITORS

DEGRADATION MODELING EXAMPLE

Capacitor Structure

- An aluminum electrolytic capacitor, consists of
 - Cathode aluminum foil,
 - Electrolytic paper, electrolyte
 - Aluminum oxide layer on the anode foil surface, which acts as the dielectric.
 - Equivalent series resistance (ESR) and capacitance(C) are electrical parameters that define capacitor health

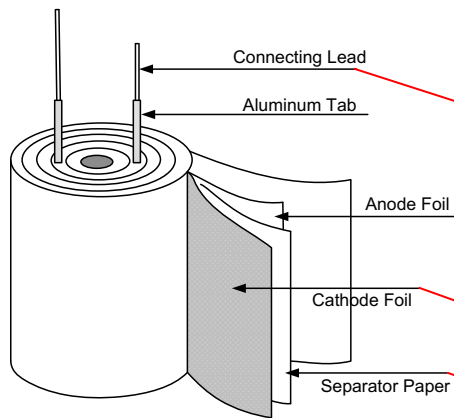

Physical Structure

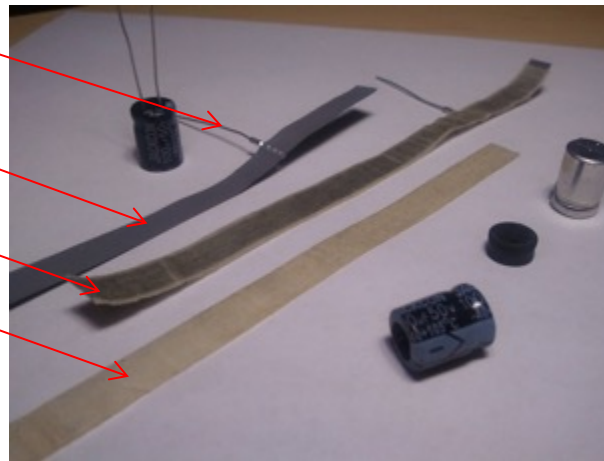

Ref

<http://en.wikipedia.org/wiki/File:ElectrolyticCapacitorDisassembled.jpg>

Open Structure

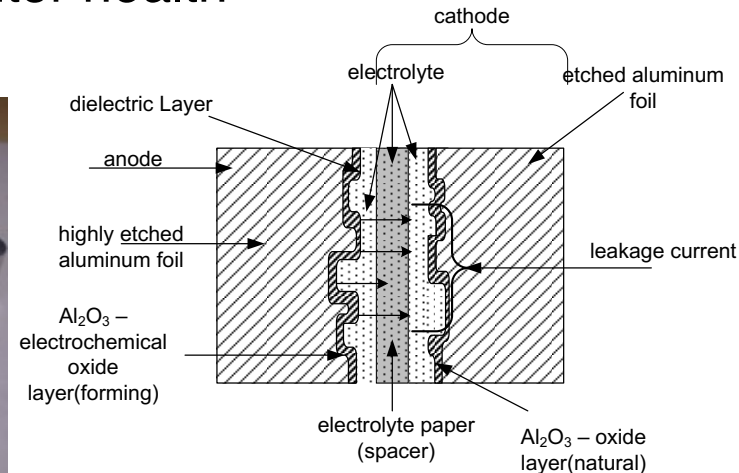

Internal Structure

Degradation Mechanisms

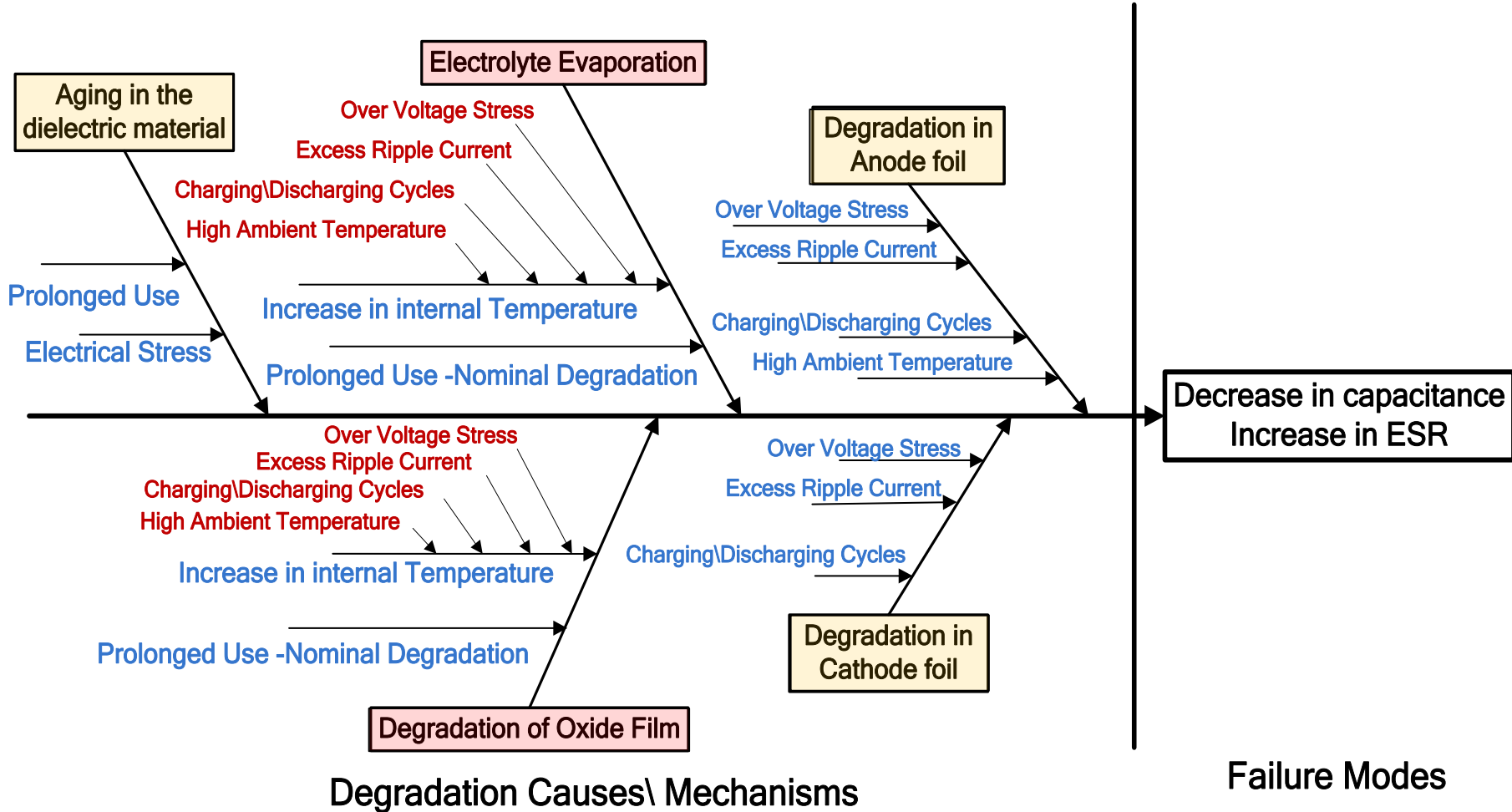

Capacitor Degradation Model

Pristine Capacitor

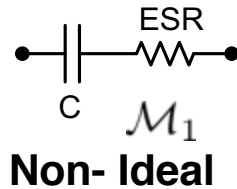
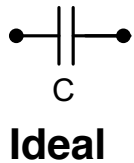

Degradation

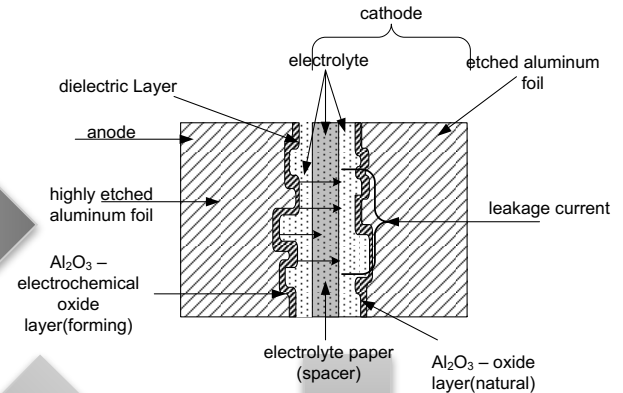

Electrolyte volume V_e maximum
Capacitance Value maximum

Thermal Stress

Electrical Stress

Avg. surface area decreases (A_s) +
oxide layer breakdown

Electrolyte degradation + Decrease
in (A_s) + crystallization + oxide layer
breakdown

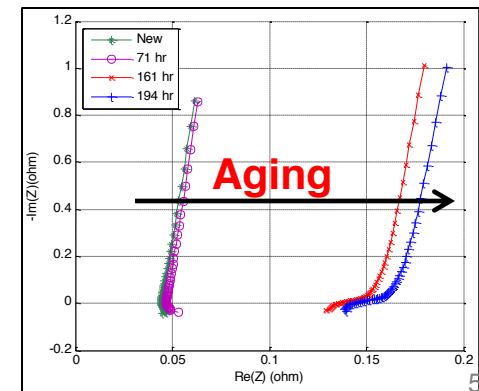
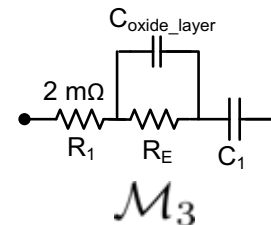
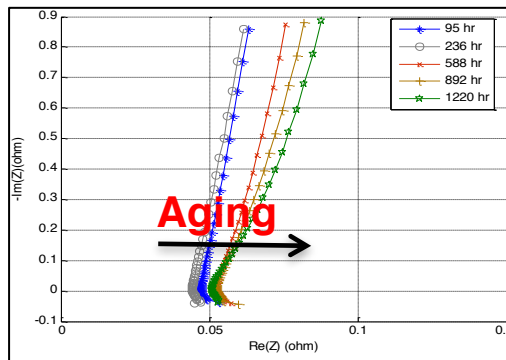
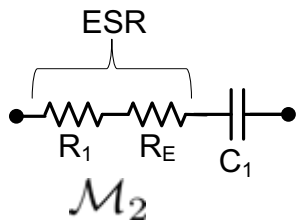

End of Case Study III:

QUESTIONS?

CASE STUDY IV: PROGNOSTICS OF LI-ION BATTERIES

DEGRADATION/AGING MODELING EXAMPLE

Battery Modeling

– Equivalent Circuit Empirical Models

- Most common approach
- Various model complexities used
- Difficulty in incorporating aging effects

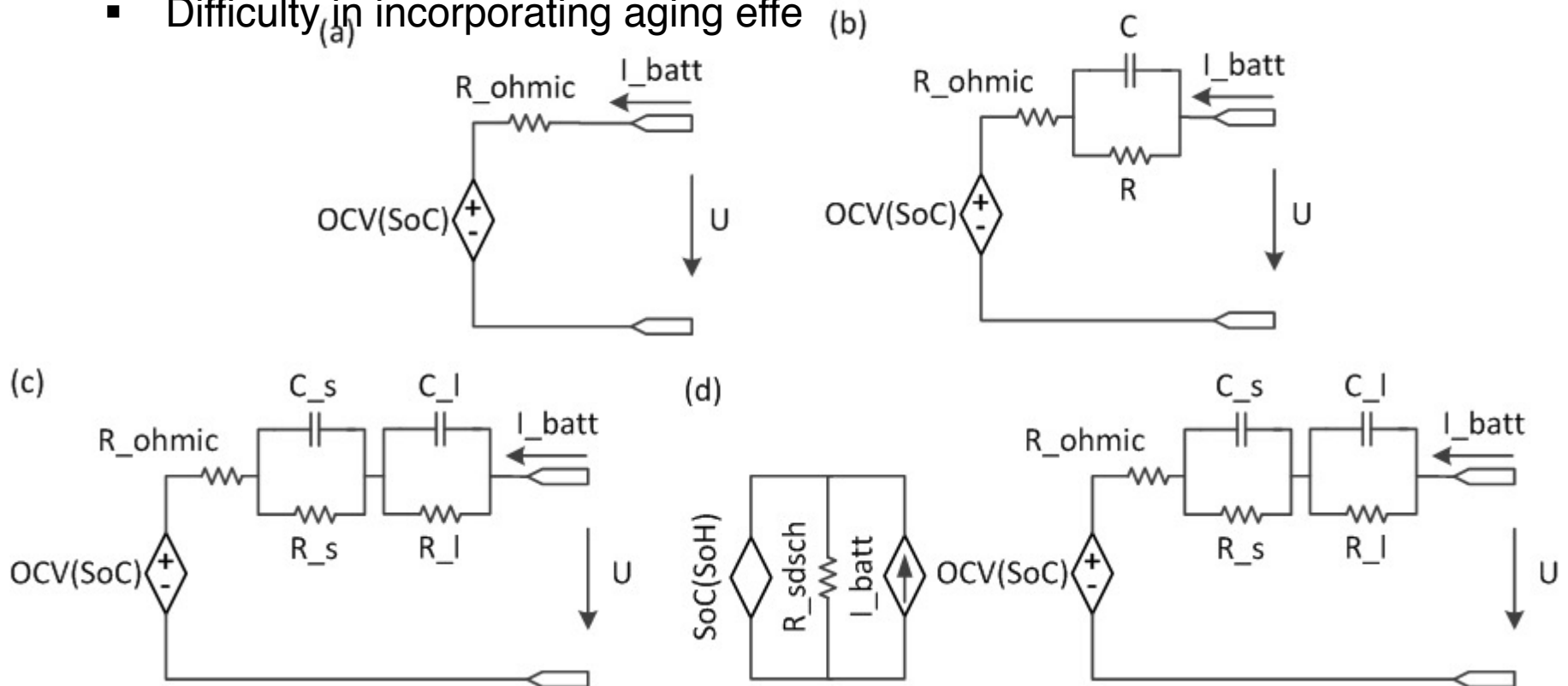

Battery Model – Tuned using Lab Data

- An equivalent circuit battery model is used to represent the battery terminal voltage as a function of current and the charge stored in 3 capacitive elements

$$x = [q_b \ q_{cp} \ q_{Cs}]^T$$

$$\dot{x} = \begin{bmatrix} 0 & 0 & 0 \\ 0 & -\frac{1}{R_{cp}C_{cp}} & 0 \\ 0 & 0 & -\frac{1}{R_sC_s} \end{bmatrix} x + \begin{bmatrix} -1 \\ 1 \\ 1 \end{bmatrix} i + \xi$$

$$y = V = \begin{bmatrix} \frac{1}{C_b} & -\frac{1}{C_{cp}} & -\frac{1}{C_s} \end{bmatrix} \cdot x$$

- Two laboratory loading experiments are used to fit the following parameterization coefficients

$$SOC = 1 - \frac{q_{max} - q_b}{C_{max}}$$

$$C_b = C_{Cb0} + C_{Cb1} \cdot SOC + C_{Cb2} \cdot SOC^2 + C_{Cb3} \cdot SOC^3$$

$$C_{cp} = C_{cp0} + C_{cp1} \cdot \exp(C_{cp2}(1 - SOC))$$

$$R_{cp} = R_{cp0} + R_{cp1} \cdot \exp(R_{cp2}(1 - SOC))$$

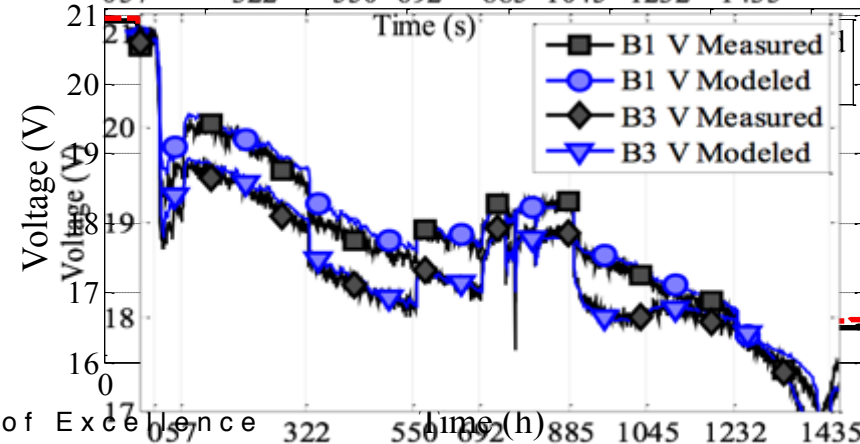
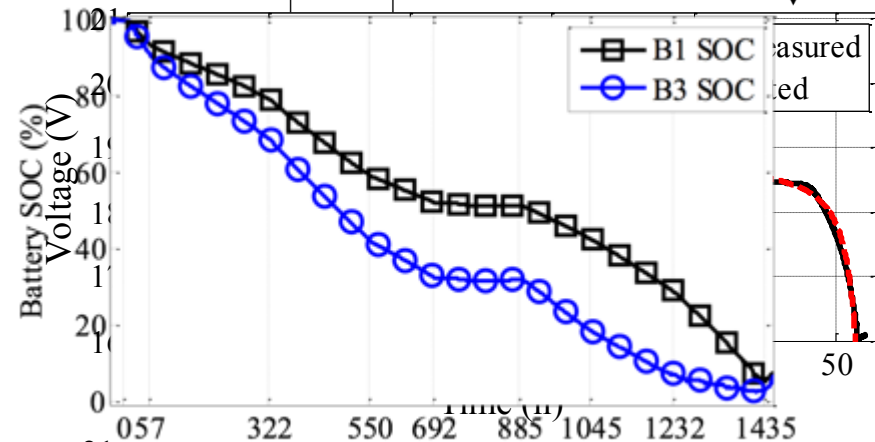
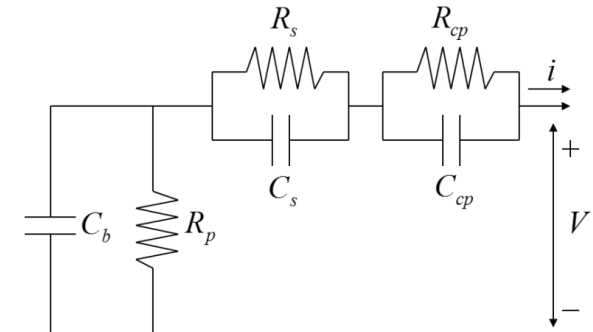

End of Case Study IV:

QUESTIONS?

Data Sets Available for Download

- <https://ti.arc.nasa.gov/tech/dash/pcoe/prognostic-data-repository/>

Randomized Battery Usage Data Set

Publications using this data set

Description	Batteries are continuously cycled with randomly generated current profiles. Reference charging and discharging cycles are also performed after a fixed interval of randomized usage in order to provide reference benchmarks for battery state of health.
Format	
Datasets	<ul style="list-style-type: none"> + Download Randomized Battery Usage Data Set 1 (1285 downloads) + Download Randomized Battery Usage Data Set 2 (936 downloads) + Download Randomized Battery Usage Data Set 3 (906 downloads) + Download Randomized Battery Usage Data Set 4 (4217 downloads) + Download Randomized Battery Usage Data Set 5 (825 downloads) + Download Randomized Battery Usage Data Set 6 (890 downloads) + Download Randomized Battery Usage Data Set 7 (857 downloads)
Dataset Citation	B. Bole, C. Kulkarni, and M. Daigle "Randomized Battery Usage Data Set", NASA Ames Prognostics Data Repository (http://ti.arc.nasa.gov/project/prognostic-data-repository), NASA Ames Research Center, Moffett Field, CA
Publication Citation	B. Bole, C. Kulkarni, and M. Daigle, 'Adaptation of an Electrochemistry-based Li-Ion Battery Model to Account for Deterioration Observed Under Randomized Use', Annual Conference of the Prognostics and Health Management Society, 2014

HIRF Battery Data Set

Publications using this data set

Description	Battery Data collected from the Experiments on the Edge 540 Aircraft in HIRF Chamber. Reference document can be downloaded here
Format	The set is in .mat format and has been zipped.
Datasets	<ul style="list-style-type: none"> + Download HIRF Battery Data Set 1 (184 downloads) + Download HIRF Battery Data Set 2 (127 downloads) + Download HIRF Battery Data Set 3 (131 downloads) + Download HIRF Battery Data Set 4 (125 downloads) + Download HIRF Battery Data Set 5 (149 downloads) + Download HIRF Battery Data Set 6 (135 downloads)
Dataset Citation	C. Kulkarni, E. Hogge, C. Quach and K. Goebel "HIRF Battery Data Set", NASA Ames Prognostics Data Repository (http://ti.arc.nasa.gov/project/prognostic-data-repository), NASA Ames Research Center, Moffett Field, CA
Publication Citation	Verification of a Remaining Flying Time Prediction System for Small Electric Aircraft. Edward F. Hogge, Brian M. Bole, Sixto L. Vazquez, Jose R., Annual Conference of the Prognostics and Health Management, PHM 2015

CLOSING REMARKS

Remarks (1/2)

- Electrical and Electronics PHM Maturity - scientific and engineering challenges
- Research approach challenges
 - How to balance lack of knowledge of the system vs own expertise on particular PHM tools
 - Data-driven or model-based?
 - Data is always needed but more important, information about degradation/aging processes is key
 - Experiments and field data

Remarks (2/2)

- Aging systems as a research tool
 - Value in terms of exploration of precursors of failure and their measurements is evident
 - Still an open question on how degradation models and algorithms are translated to the real usage timescale
- In the use of physics
 - It should be embraced
- Validate models and algorithms with data from lab experiments and fielded systems
- A success in developing PHM methodologies in an real usage application will require the right team

Acknowledgments

- Collaborators
 - Kai Goebel, NASA Ames Research Center
 - José Celaya, Schlumberger
 - Matthew Daigle, NIO
 - Edward Hogge, Northrop Grumman Technology Services, NASA Langley
 - George Gorospe, SGT, Inc., NASA Ames Research Center
 - Cuong “Patrick” Quach, NASA Langley
 - Abhinav Saxena, GE
 - Brian Bole
 - Christopher Teubert, SGT, Inc., NASA Ames Research Center
 - Edward Balaban, NASA Ames Research Center
 - Adam Sweet, NASA Ames Research Center
 - Anibal Bregon, University of Valladolid
 - Shankar Sankararaman, SGT, Inc., NASA Ames Research Center
- Funding Projects
 - NASA System-wide Safety and Assurance Technologies Project
 - NASA Aviation Safety Program – IVHM Project
 - NASA SMART –NAS Project

Publications (1/3)

- [1] C. Kulkarni, G. Biswas, X. Koutsoukos, J. Celaya, and K. Goebel, “Integrated diagnostic/prognostic experimental setup for capacitor degradation and health monitoring,” in *IEEE AUTOTESTCON, 2010*, (Big Sky, MT), pp. 1–7, 2010.
- [2] C. Kulkarni, G. Biswas, X. Koutsoukos, J. Celaya, and K. Goebel, “Aging methodologies and prognostic health management for electrolytic capacitors,” in *Annual Conference of the Prognostics and Health Management Society 2010*, (Portland, OR), 2010.
- [3] C. Kulkarni, G. Biswas, X. Koutsoukos, J. Celaya, and K. Goebel, “Diagnostic/prognostic experiments for capacitor degradation and health monitoring in DC-DC converters,” in *ASME 2010 Conference on Smart Materials, Adaptive Structures and Intelligent Systems*, (Philadelphia, PA), 2010.
- [4] J. Celaya, C. Kulkarni, G. Biswas, S. Saha and K. Goebel, “A Model-based Prognostics Methodology for Electrolytic Capacitors Based on Electrical Overstress Accelerated Aging”, Proceedings of Annual Conference of the Prognostics and Health Management Society, September 25-29, 2011, Montreal, Canada.
- [5] C. Kulkarni, J. Celaya, G. Biswas, and K. Goebel, “Physics Based Degradation Models for Capacitor Prognostics under Thermal Overstress Conditions”, *International Journal of Prognostics and Health Management*, 2013 Vol 4 (1) 005.
- [6] G. Sonnenfeld, K. Goebel, and J. R. Celaya, “An agile accelerated aging, characterization and scenario simulation system for gate controlled power transistors,” in *IEEE AUTOTESTCON 2008*, pp. 208–215, 2008.
- [7] J. R. Celaya, N. Patil, S. Saha, P. Wycoki, and K. Goebel, “Towards accelerated aging methodologies and health management of power MOSFETs,” in *Annual Conference of the Prognostics and Health Management Society, 2009*, (San Diego, CA), 2009.
- [8] J. R. Celaya, S. Saha, P. Wycoki, and K. F. Goebel, “Effects of lightning injection on power-MOSFETs,” in *Annual Conference of the Prognostics and Health Management Society, 2009*, (San Diego, CA), 2009.

Publications (2/3)

- [9] N. Patil, J. Celaya, D. Das, K. Goebel, and M. Pecht, "Precursor parameter identification for insulated gate bipolar transistor (IGBT) prognostics," *IEEE Transactions on Reliability*, vol. 58, no. 2, pp. 271–276, 2009.
- [10] B. Saha, J. R. Celaya, P. F. Wysocki, and K. F. Goebel, "Towards prognostics for electronics components," in *IEEE Aerospace conference 2009*, (Big Sky, MT), pp. 1–7, 2009.
- [11] P. Wysocki, V. Vashchenko, J. Celaya, S. Saha, and K. Goebel, "Effect of electrostatic discharge on electrical characteristics of discrete electronic components," in *Annual Conference of the Prognostics and Health Management Society, 2009*, (San Diego, CA), 2009.
- [12] J. Celaya, A. Saxena, P. Wysocki, S. Saha, and K. Goebel, "Towards prognostics of power MOSFETs: Accelerated aging and precursors of failure," in *Annual Conference of the Prognostics and Health Management Society 2010*, (Portland, OR), 2010.
- [13] J. J. Ely, T. X. Nguyen, G. N. Szatkowski, S. V. Koppen, J. J. Mielnik, R. K. Vaughan, P. F. Wysocki, J. R. Celaya, and S. Saha, "Lightning pin injection testing on MOSFETS," *NASA Technical Memorandum*, vol. TM-2009-215794, 2009.
- [14] J. R. Celaya, P. Wysocki, V. Vashchenko, S. Saha, and K. Goebel, "Accelerated aging system for prognostics of power semiconductor devices," in *IEEE AUTOTESTCON, 2010*, (Orlando, FL), pp. 1–6, 2010.
- [15] A. E. Ginart, I. N. Ali, J. R. Celaya, P. W. Kalgren, D. P. S, and M. J. Roemer, "Modeling SiO₂ ion impurities aging in insulated gate power devices under temperature and voltage stress," in *Annual Conference of the Prognostics and Health Management Society 2010*, (Portland, OR), 2010.
- [16] S. Saha, J. Celaya, B. Saha, P. Wysocki, and K. Goebel, "Towards modeling the effects of lightning injection on power MOSFETs," in *Annual Conference of the Prognostics and Health Management Society 2010*, (Portland, OR), 2010.
- [17] S. P. Bharadwaj, A. E. Ginart, I. N. Ali, P. W. Kalgren, J. Celaya, and S. Poll, "Solar cells aging estimation based on impedance characterization," in *IEEE Aerospace Conference 2011*, (Big Sky, MT), 2011.

Publications (3/3)

- [18] J. R. Celaya, C. Kulkarni, G. Biswas, and K. Goebel, "Towards prognostics of electrolytic capacitors," in *AIAA Infotech@Aerospace 2011*, (St. Louis, MO), 2011.
- [19] J. R. Celaya, A. Saxena, V. Vashchenko, S. Saha, and K. Goebel, "Prognostics of power MOSFET," in *23rd International Symposium on Power Semiconductor Devices and ICs*, (San Diego, CA), 2011.
- [20] J. J. Ely, T. X. Nguyen, G. N. Szatkowski, S. V. Koppen, J. J. Mielnik, R. K. Vaughan, P. F. Wysocki, J. R. Celaya, and S. Saha, "Lightning pin injection test: MOSFETS in "ON" state," *NASA Technical Memorandum*, 2011.
- [21] Raj Bharadwaj, K. Kim, C. Kulkarni, G. Biswas, "Model-Based Avionics Systems Fault Simulation and Detection", American Institute of Aeronautics and Astronautics, Infotech@Aerospace 2010, April 2010, Atlanta, GA.
- [22] C. Kulkarni, G. Biswas, J. Celaya, and K. Goebel, "Prognostics techniques for capacitor degradation and health monitoring," in *The Maintenance and Reliability Conference (MARCON)*, (Knoxville TN), 2011.
- [23] E. Hogge et al, "Verification of a Remaining Flying Time Prediction System for Small Electric Aircraft", PHM 2015
- [24] E. Hogge, , C. Kulkarni, S. Vazquez, K. Smalling, T. Strom, B. Hill, C. Quach "Flight Tests of a Remaining Flying Time Prediction System for Small Electric Aircraft', Proceedings of the Annual Conference of the Prognostics and Health Management Society 2017 (to be published)
- [25] G. Gorospe, C. Kulkarni, E. Hogge, A. Hsu, N. Ownby, "A Study of the Degradation of Electronic Speed Controllers for Brushless DC Motors", Proceedings Asia Pacific Conference of the Prognostics and Health Management Society 2017, Jeju, South Korea (to be published)

Questions

THANK YOU!