

# Pathways Intern Report

Daniel James Huggett

Mechanical Engineering  
Louisiana State University  
PhD Candidate

NE-XY

GS-7

Spring-Summer 2017

dhugge1@lsu.edu

Work Phone: 321-687-3520

**NASA Supervisor:**    **Patrick Maloney**

**NASA Mentor:**        **David Chesnutt**

## 1. Introduction

The National Aeronautics and Space Administration (NASA) provides a formal training program for prospective employees titled, Pathways Intern Employment. This program targets graduate/undergraduate students who strive to become an active contributor to NASA's goal of space exploration. The Pathways program offers students invaluable experience and knowledge required to be successful in the challenging aerospace discipline.

A Pathways intern works semester rotations between NASA and school until graduation. This design is conducive for accelerating a student's training for employment. The student has the opportunity to apply knowledge gained from academics to real-world problems encountered at NASA. Moreover, a student has the unique opportunity to interact with NASA personnel on a day-to-day basis. In this report, a synopsis of Daniel Huggett's final work rotation in the engineering analysis branch (NE-XY) at Kennedy Space Center (KSC) during spring and summer 2017 is provided. The remaining sections are organized as follows: **Section 2** provides a summary of three projects conducted, **Section 3** provides an evaluation of work significance to the student's career and educational development, and lastly **Section 4** outlines conclusions.

## 2. Projects Assigned

### 2.1. TSMU Flex Hose Modeling and Experimental Testing

The Tail Service Mast Umbilical (TSMU) will play a vital role in launching the Space Launch System (SLS). The TSMU system relies on flex hoses to provide commodities to the SLS core stage, as seen in **Figure 1**. These flex hoses are attached to the vehicle via ground umbilical carrier assemblies which impart loads to the rocket. In order to estimate these loads, dynamic models are constructed to predict launch day conditions; however, flex hose properties are difficult to model due to their non-linear responding over-braided convolute design. In order to develop the best model to predict flex hose response, experimental testing was conducted to extract features of the TSMU flex hoses. The data obtained from testing was utilized to build a dynamic model with ADAMS, a multi-body dynamic analysis software package by MSC, to simulate the experimental results. The modeling technique and property database developed in this study will be incorporated in future dynamic models to simulate launch day conditions. An example of the ADAMS model response and experimental data overlay is provided in **Figure 2**.

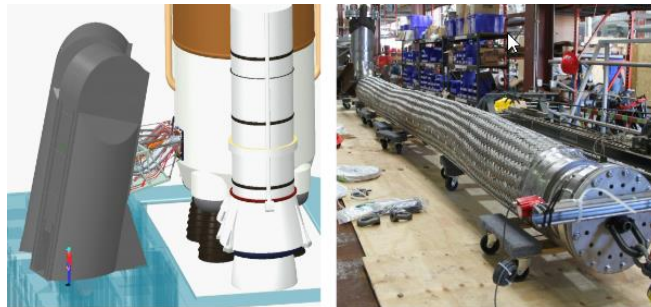

**Figure 1:** TSMU located on mobile launcher (ML) providing the T-0 connection to the SLS core stage (left) and an 8x10 LH2 flex hose illustrating lab test environment (right)

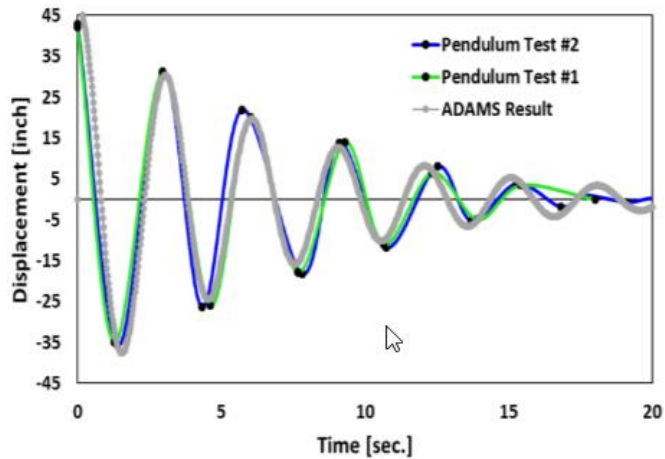
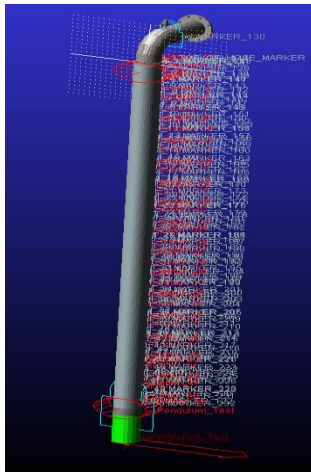

**Figure 2:** 8x10 flex hose ADAMS model (left) and dynamic model results overlaid with experimental test data (right)

## 2.2. Crawler Transporter Loads Model Development

The crawler transporter (CT) has provided access to transfer launch vehicles from the vehicle assembly building (VAB) to launch pad complex 39 for multiple NASA programs. The CT was recently upgraded for the SLS program to accommodate additional weight requirements. Through the years, models of the crawler have been made to predict performance; however, to date there is not a complete model that replicates mass distribution of the crawler with its new modifications. Mass distribution inside the crawler is important to determine the vehicle base excitations during rollout operations. For this reason, development of a new CT model was initiated by NE-XY. Tasks as a part of the modeling efforts included mid-surfacing and meshing the CT truck steering arms and researching crawler internal components to augment the fidelity of point mass distributions in the higher level assembly finite element model of the transporter. In this work, Siemens NX version 11 was utilized, and results of the work can be observed in **Figures 3 and 4**.

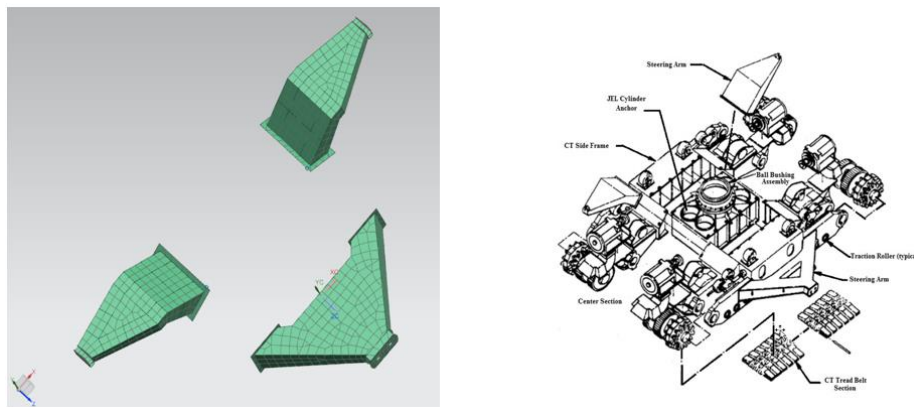

**Figure 3:** CT truck in- and outboard steering arms with coarse 10 inch mesh (left) and CT truck assembly drawing illustrating location of each steering arm with respect to truck structure (right)

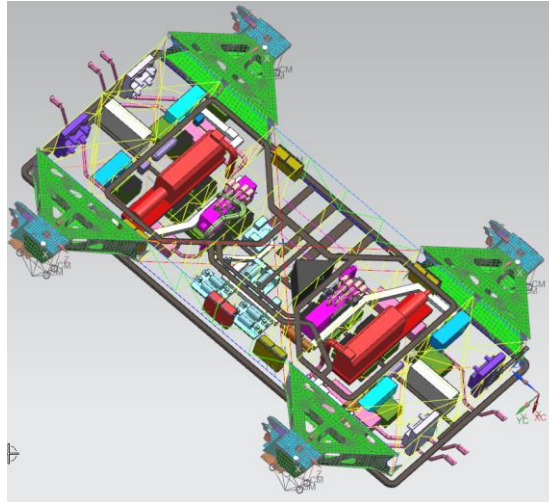

**Figure 4:** CT chassis with internal components added to better predict actual load distribution

### 2.3. Python Engineering Analysis Tool

The engineering analysis branch at KSC developed an Excel tool to aid day-to-day work tasks. The tool encompasses a wide range of topics from weld allowable stress to fastener stiffness calculations. This tool has the capability to increase efficiency of the analyst; however, the current tool is not readily accessible in its current form. To increase usability of the tool, conversion of the Excel framework to Python executable functions is underway. A snippet of Python code is provided in **Figure 5**.

```

from Fastener_Case import F_Case
from numpy import pi, tan, sin, cos, log

def Joint_Stiff():
    import xlrd
    import xlswriter

    #Define Workbook
    workbook = xlswriter.Workbook('Joint Stiffness.xlsx')
    worksheet1 = workbook.add_worksheet('Joint Stiffness Results')
    -----Referenced Section-----
    F_Case_Data=F_Case()

    #Open Material Excel Data Sheet
    Material_File = xlrd.open_workbook('Base Material Prop.xlsx')

    Base_Mat_sheet = Material_File.sheet_by_index(0)
    Fastener_Mat_sheet = Material_File.sheet_by_index(1)
    Fastener_Geom_sheet = Material_File.sheet_by_index(2)

    Base_Mat_data = [[Base_Mat_sheet.cell_value(r,c) for c in range(Base_Mat_sheet.ncols)] for r in range(Base_Mat_sheet.nrows)]
    Fastener_Mat_data = [[Fastener_Mat_sheet.cell_value(r,c) for c in range(Fastener_Mat_sheet.ncols)] for r in range(Fastener_Mat_sheet.nrows)]
    Fastener_Geom_data = [[Fastener_Geom_sheet.cell_value(r,c) for c in range(Fastener_Geom_sheet.ncols)] for r in range(Fastener_Geom_sheet.nrows)]

    #Type 1, q, 1; Type 2, q, 2; Type 3, q, 3
    counter = 1
    while counter < 3:

        #Joint Stiffness Input Parameter
        Washer_U_Head = F_Case_Data[0][0][1] + counter
        Washer_U_Nut = F_Case_Data[0][1][1] + counter
        Number_Thor_Wash_Layer = F_Case_Data[0][2][1] + counter
        Frustrum_Angle_deg = F_Case_Data[0][3][1] + counter
        Frustrum_Angle_rad = Frustrum_Angle_deg*(pi/180)
        Head_Diameter = F_Case_Data[0][4][1] + counter
        Nut_Diameter = F_Case_Data[0][5][1] + counter
        Hole_Diameter = F_Case_Data[0][6][1] + counter

        Washer_Head_Thickness = F_Case_Data[0][7][1] + counter
        Washer_Nut_Thickness = F_Case_Data[0][8][1] + counter
    
```

**Figure 5:** Python code example illustrating a function that calculates joint stiffness

### 3. Significance of Work as Related to School and Career

Disciplines of dynamics, finite elements, material science, and structural mechanics were utilized to complete work tasks. Work responsibilities were supplemented by training courses

including fundamentals of vibration, design and fabrication of pressure vessels, introduction to 3-D printing, and welding and cutting hazards in construction. Learning these disciplines and applying them for NASA's mission greatly benefited the student, as skills gained can be utilized for future career and school endeavors.

#### **4. Conclusion**

The spring and summer 2017 work assignment located in NE-XY at KSC provided invaluable experience and career development opportunities. Key projects worked included TSMU flex hose modeling and testing, CT loads model development, and creation of an engineering analysis python tool. Several ancillary projects conducted included analysis of the impact ferrite has on austenitic steel weldments, creation of an ADAMS variable pitch propeller system, and analysis of the interim cryogenic propulsion stage umbilical (ICPSU) hydraulic line lengths at the launch equipment test facility (LETF) and ML. The opportunities to tour multiple KSC facilities, present at the pathways showcase, winning the galactic impact and best use of data award during the KSC space apps challenge, and learning about KSC's role for NASA were highpoints during the Pathways Program experience.