

National Aeronautics and Space Administration

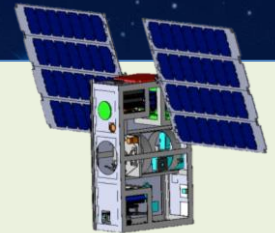

Pathfinder Technology Demonstrator GlobalStar Testing and Results

Vanessa Kuroda
Communications Subsystem Lead
April 20-22, 2016
CalPoly CubeSat Workshop

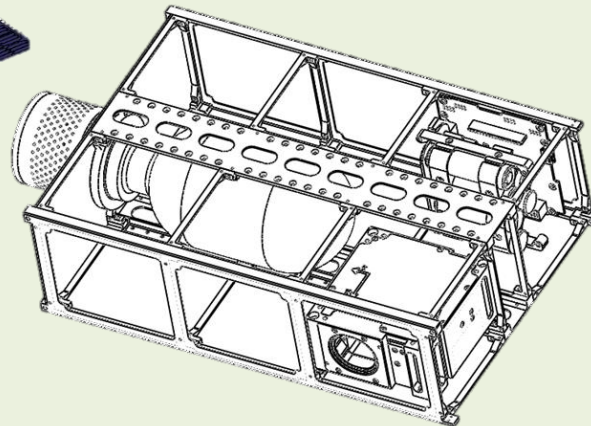

ARC Small Spacecraft Timeline

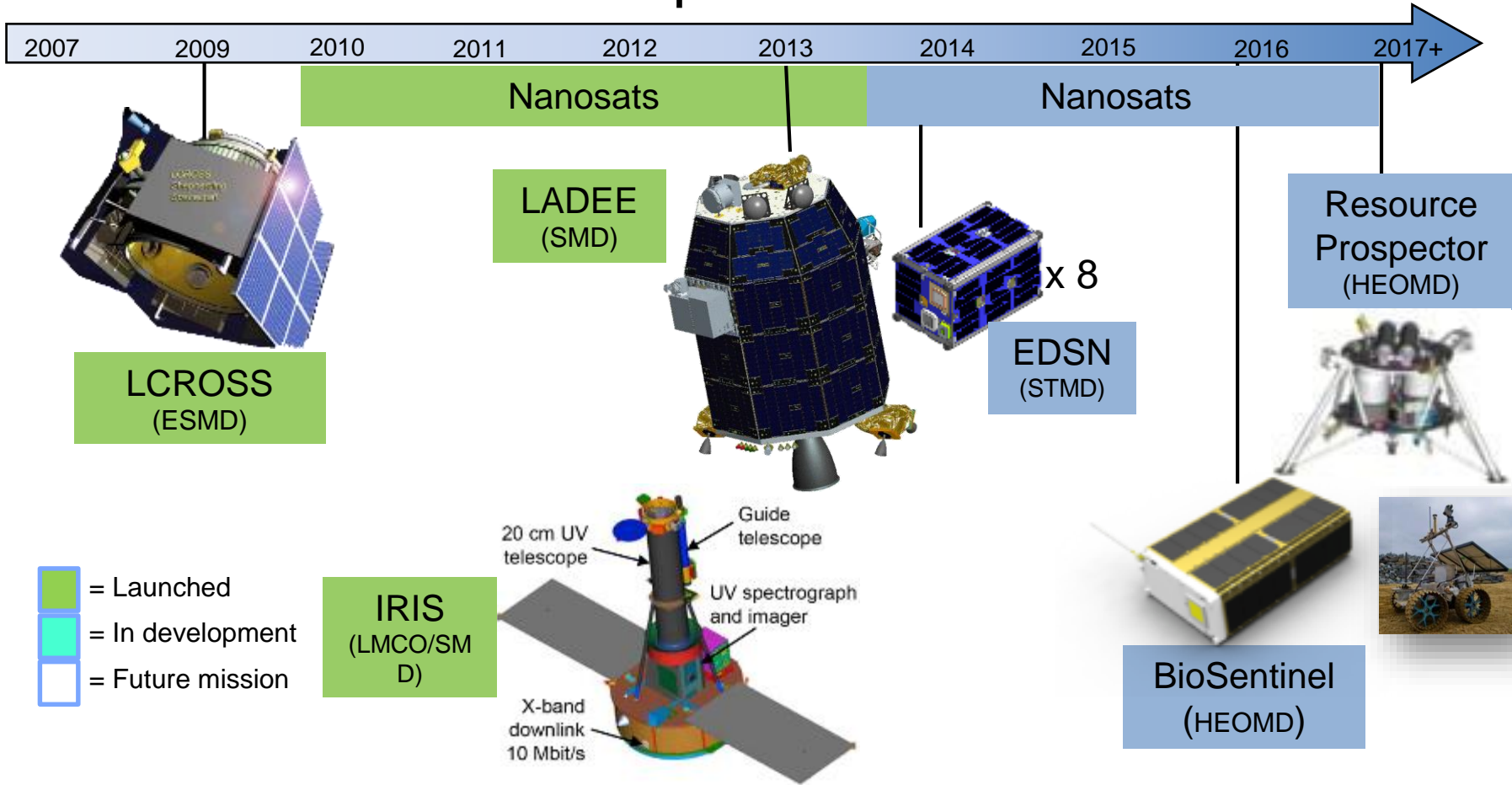

NASA-ARC continues a history of manifesting cost efficient (< \$250M) , increasingly-capable Small Satellites

ARC NanoSat Product Timeline

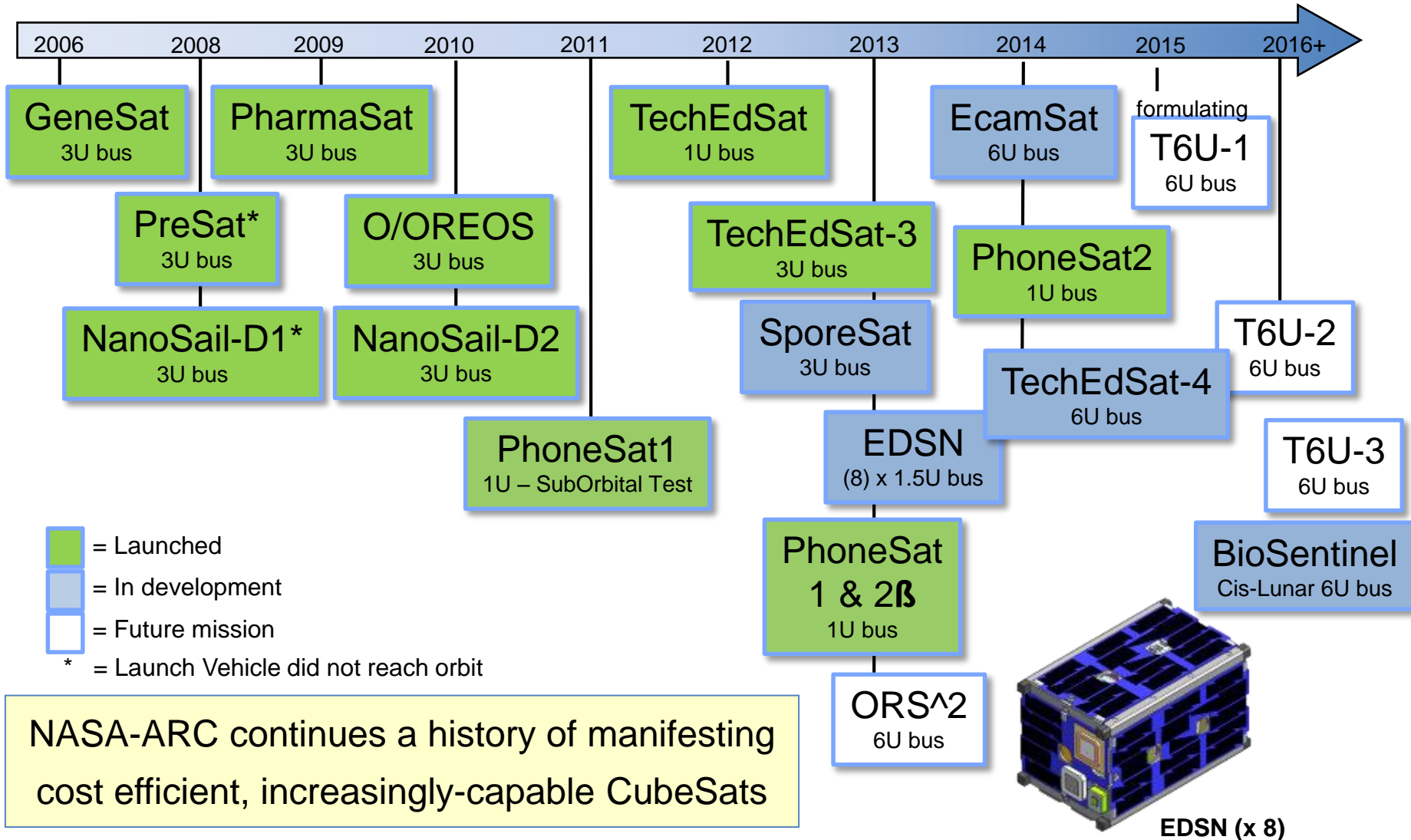

Rationale for Testing

The GlobalStar network is a constellation of satellites in LEO for satellite phones and low speed data communications.

It could be a low cost, low SWaP option for cubesat communications

The simplex unit, STX3, seems to be a good option for every cubesat to have a beacon

We were testing the duplex unit, the GSP-1720, for feasibility for the Pathfinder Technology Demonstrator Project

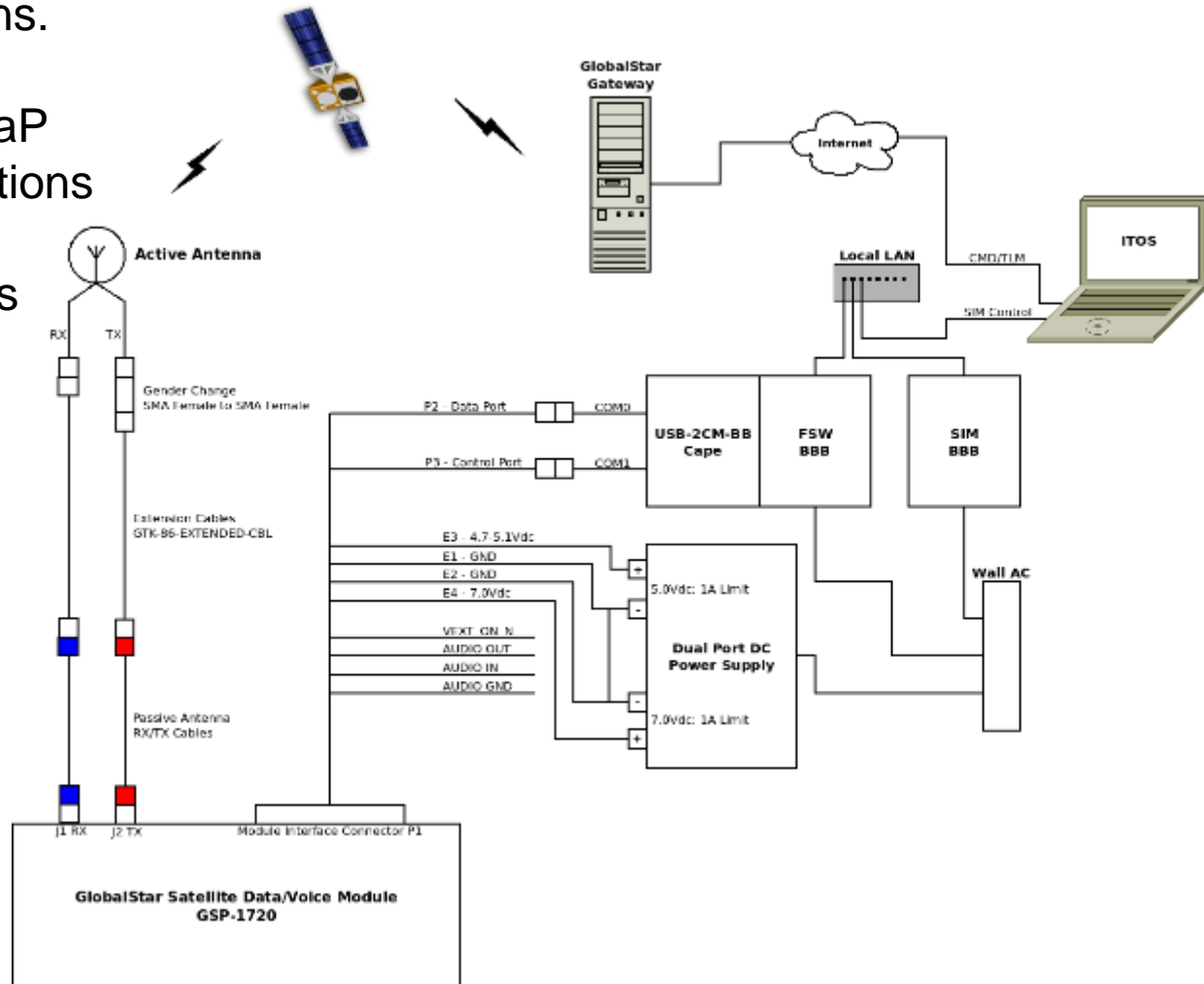

Key Questions

1. Can it survive the space environment?
2. What is the quality of the communication service?
 1. What do we mean by quality of service?
 1. Data Rate/Throughput – what can we expect it to be?
 2. How often are we going to get dropped?
 3. What does it take to re-establish the link? Does it come back on easily?
 4. How does it interact with normal spacecraft configuration?
 1. Interactions w/ BeagleBone Black and our FSW

Overview of Testing

- Vibration testing

- TVAC testing

 - 4 hot and cold cycles

 - 1 hot survival turn on

 - 1 cold survival turn on

- Performance Testing

 - Flatsat setup

 - iPerf

 - ftp

 - ITOS



GSP-1720 Duplex Modem Board

Vibration Testing

The Globalstar radio (GSP-1720) was subjected to random vibration equivalent to the GEVS qual test levels (14.2grms) using the vibration test facility in the Ames Engineering Evaluation Lab

The test timeline consisted of the following major elements:

- Pre-vibe functional test
 - Mounting of the GSP-1720 to the vibration facility
 - Performance of the test
 - Post-vibe functional test
- The GSP-1720 successfully turned on, communicated with the GlobalStar network, and transferred data after the vibration test

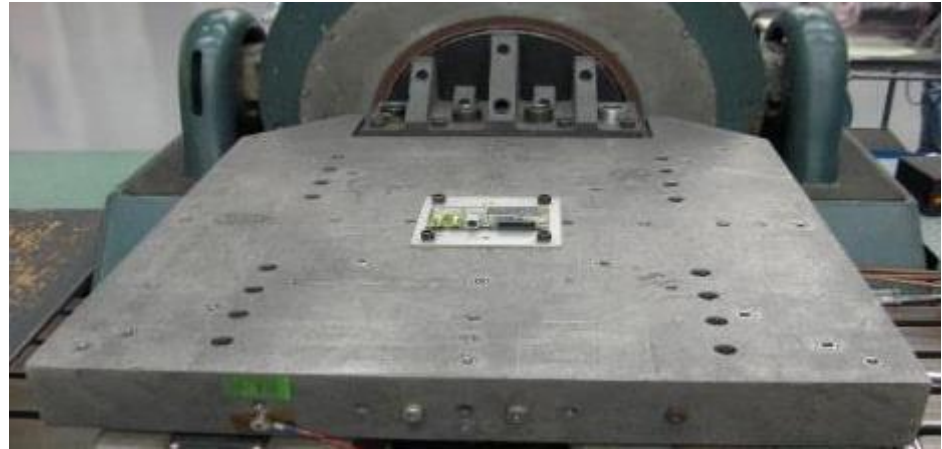

GSP-1720 on EEL Vibration Table

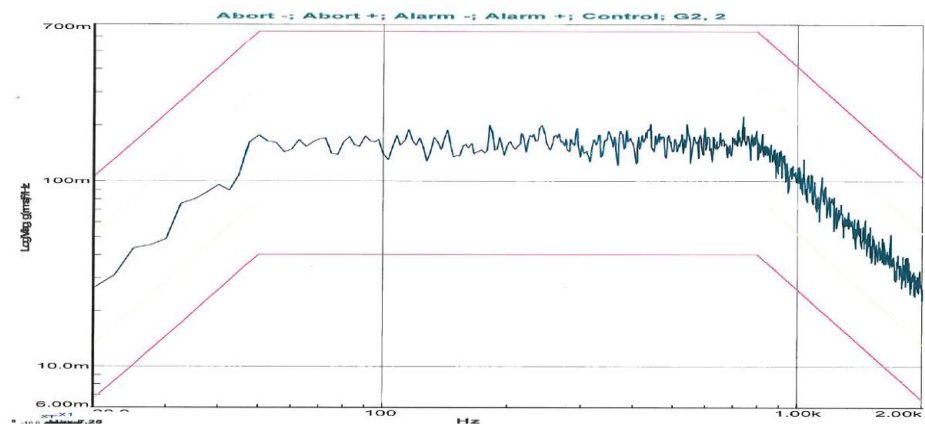

Vibe Profile

Thermal Vacuum Testing

The Globalstar radio (GSP-1720) was subjected to thermal vacuum testing using the small TVAC chamber in the Engineering Evaluation Lab (EEL) at Ames Research Center.

- The test timeline consisted of the following major elements:
- 4 thermal cycles
 - 8 proto-qualification plateaus for electrical performance testing of the component
 - 8 transitions
 - One cold and one hot survival plateau for survival turn-on
- The GSP-1720 successfully turned on, communicated with the GlobalStar network, and transferred data during each plateau and after the cycling was complete

GSP-1720 in EEL TVAC Chamber

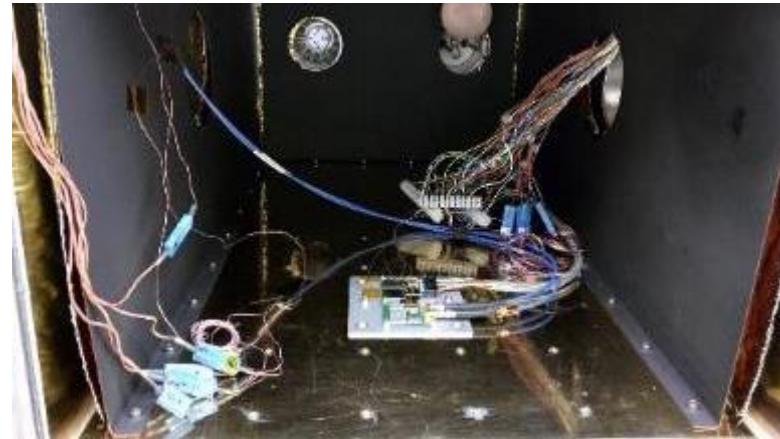

GlobalStar Temperature (deg C) vs. Time (days)

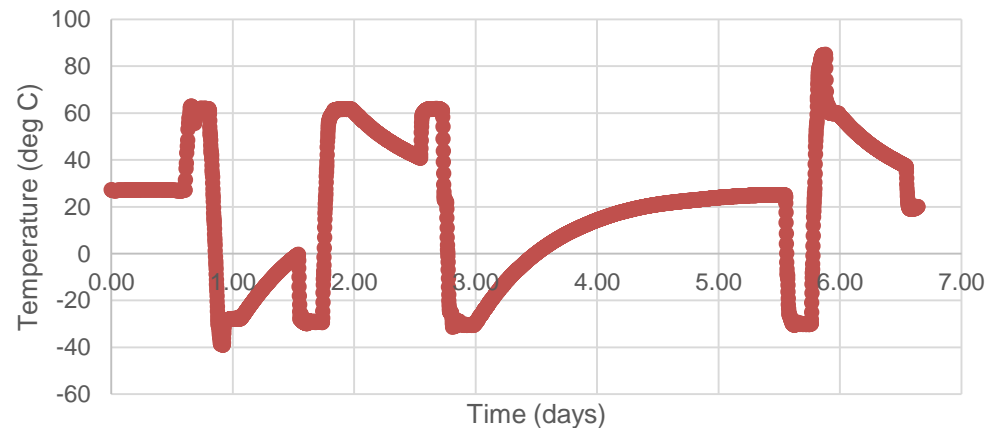

Connection Time

- System consists of four states

- Connected
- Disconnected
- Calling
- No Answer (Wait)

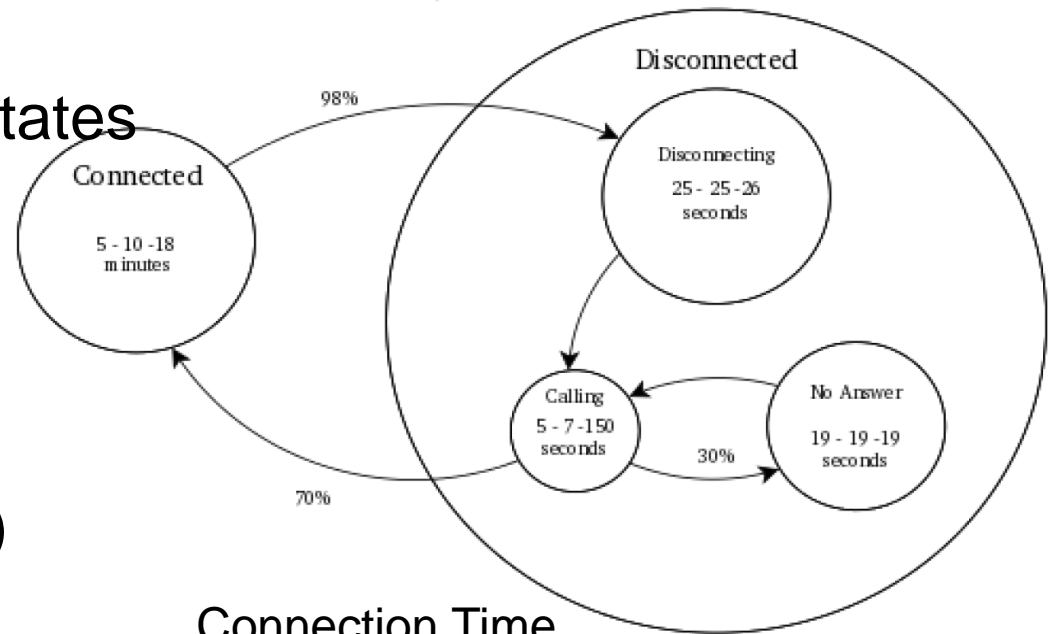

- Connected times (“pass”) varied from 5-18 minutes (25%-75%)

- Reconnection took from 30 seconds to several minutes

Connection Time

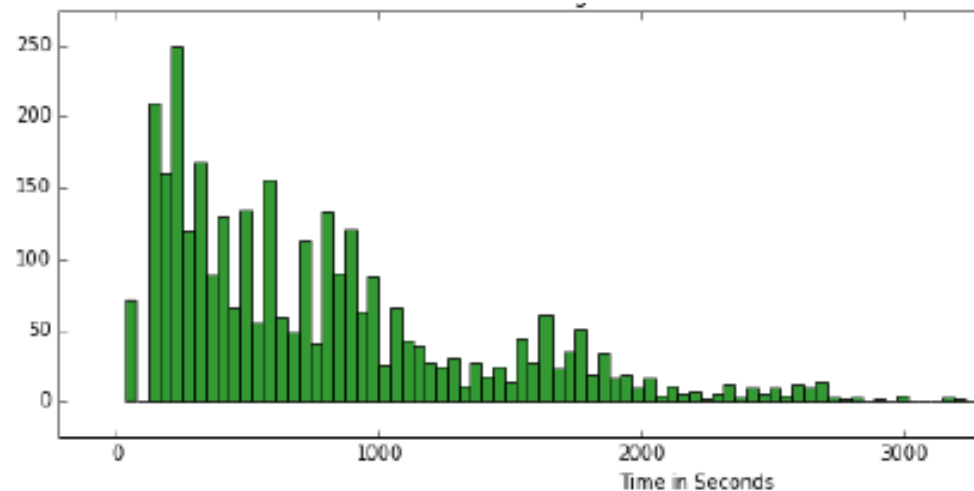

Characterization of System Jitter

- Test performed using UDP
 - Connected
 - Disconnected
 - Calling
 - No Answer (Wait)
- Jitter
 - Jitter increases w/packet size
 - Downlink worse than uplink
 - Jitter generally < 1 sec
- Packet Loss
 - Individual packet loss 10-30% for UDP (no retransmission)
 - Downlink worse than uplink

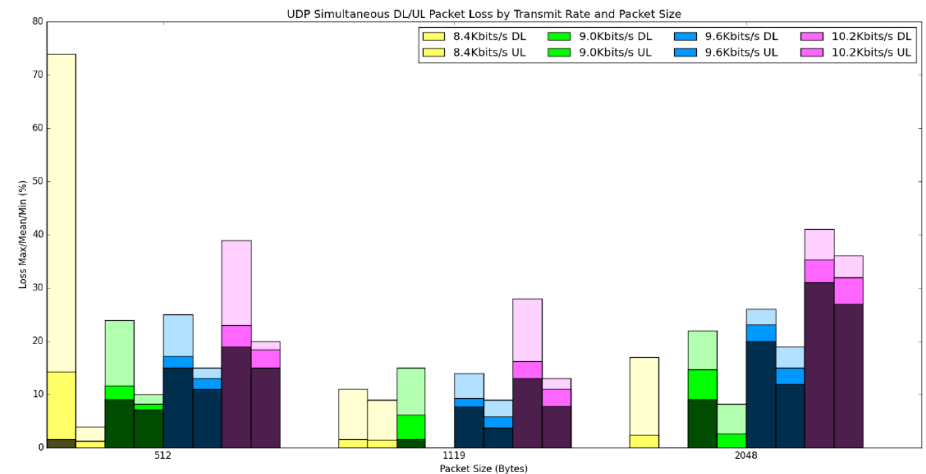
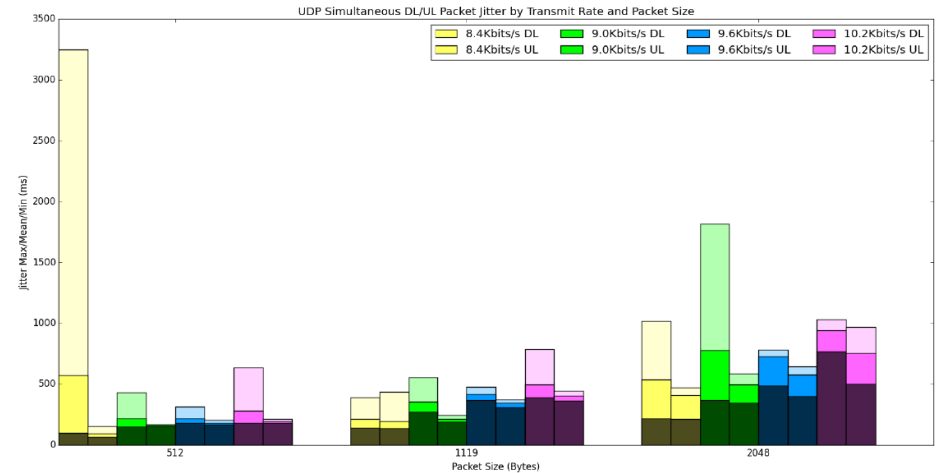

Data Rates Using TCP/IP

- Uplink and downlink data rates between spacecraft and ground system characterized over several days
- Data rate reduced by 20% due to overhead (8 kbps vs. 9.6 kbps capability)
- Some reduction in performance for:
 - Smaller packet sizes
 - Arbitrarily constrained TCP window size
 - Disabling Nagle processing

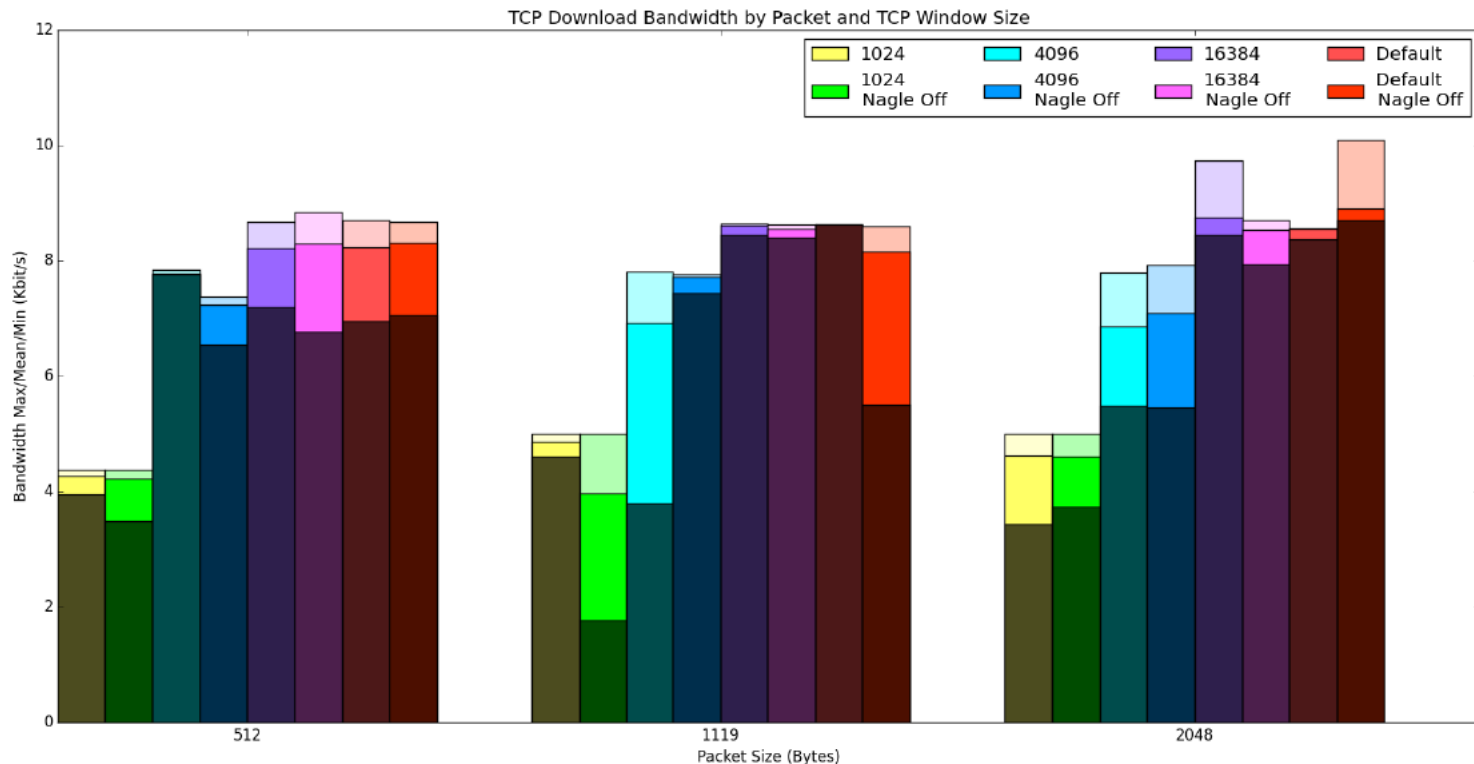

Interactions Between Ground and Flight Software

- Ground/FSW interactions characterized using full system – spacecraft, GlobalStar & ground system running ITOS
- Telemetry latency bounds calculated using timestamped events in data stream
 - Command execution
 - Receipt of data
 - Resumption of operations after waiting for housekeeping
- Command links established 108 times over several days
- Latency measured at between two and eight seconds
- Six transfer failures logged by the system

Conclusions

- GlobalStar GSP-1720 modem passed vibration and TVAC tests to GEVS levels
- Modem successfully integrated with existing NASA flight software and ground system
 - LADEE flight software running on BeagleBone Black with cFS/cFE stack
 - ITOS ground software suite running on LINUX box
- Performance of overall system characterized
 - Successfully ran UDP, PPP, FTP and TCP/IP protocols
 - Jitter and throughput reasonably close to expected capability of system
 - Larger packet size transfers were more efficient
 - Loss of signal was handled autonomously, although the time for reconnection varied
 - Simultaneous uplink and downlink did not affect overall performance
- Demonstrated CFDP – CCSDS File Delivery Protocol
- Further characterization required on-orbit
 - Ground tests did not include GlobalStar spacecraft or Ground Station hand offs
 - Re-acquisition time will depend on relative positions of spacecraft and GlobalStar constellation

Questions?

National Aeronautics and Space Administration



Acknowledgements:

-Pathfinder Technology Demonstrator Project, funded by NASA STMD/SSTP
(Space Technology Mission Directorate/Small Spacecraft Technology Program)

-John Hanson

-John Marmie

-NASA Ames Small Sat FSW Team

-Greg Limes

-Shi Lei Han

-Scott Christa

-Pat Castle

-Andy Goforth

-GlobalStar – Joe Crowley

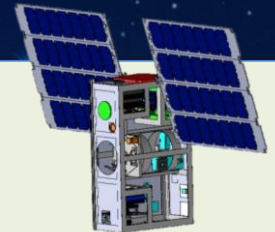
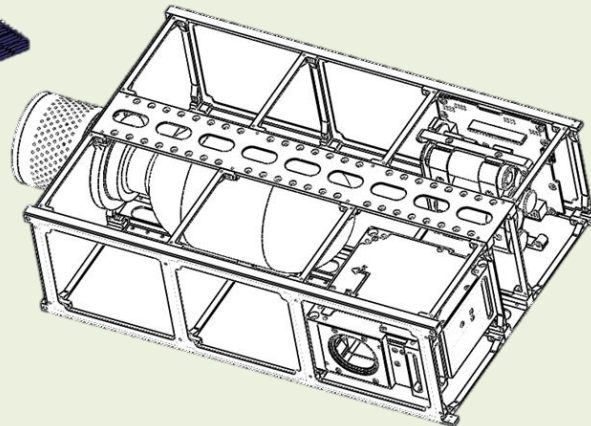

Questions/Work Forward

- Still need to fully analyze the results and collate into presentations, papers, etc
- What should we focus on, what would be most useful to SSTP?
- Do we want to analyze the ITOS data?
- What kind of results are we looking for?
- Questions to GlobalStar
 - making it smaller?
 - Business case? Are they ready/accommodating?
- Data throughput
 - Is it worth, an 8k file, how long would it take, can we do it all day?
- Ground implementation?
- Connection time, deviation, min/max
- Include unknowns and concerns
- PTD data volume requirement: 250 Mbits per day
- current PTD command requirement: “near real time” – a few seconds

Performance Testing

The Globalstar radio (GSP-1720) was subjected to performance testing using a setup in the trailers near Building N269, and some limited testing in the N213 Penthouse.

-iPerf testing

-iPerf3 is a tool for active measurements of the maximum achievable bandwidth on IP networks. The test requires running a server on an Internet accessible workstation with static IP and a client on the GlobalStar modem host. The necessary test scripts and result processing scripts can be found in the PPF Git repository.

<https://babelfish.arc.nasa.gov/confluence/display/PPFFSW/iPerf3+Tests+for+GlobalStar+Modem>

-ftp testing

-The File Transfer Protocol (FTP) is a standard network protocol used to transfer files from one host to another host over a TCP-based network. The purpose of this test is see whether FTP file transfer is a good candidate for the GlobalStar network. For this test the FTP server is configured on the GlobalStar modem host (BeagleBone Black). The script is written to automatically upload, download and then delete 4 files (1KB, 10KB, 100KB and 1MB) with random content to the FTP server. The script will also restart/continue the FTP transfer if it fails. The ftp_test_parser.py script extracts and process the log file output.

<https://babelfish.arc.nasa.gov/confluence/display/PPFFSW/FTP+Tests+for+GlobalStar+Modem>

-ITOS testing

-ITOS is used for command and telemetry. Commanding, downloading, and CFDP (CCSDS File Delivery Protocol) tests were performed

Pathfinder Technology Demonstrator

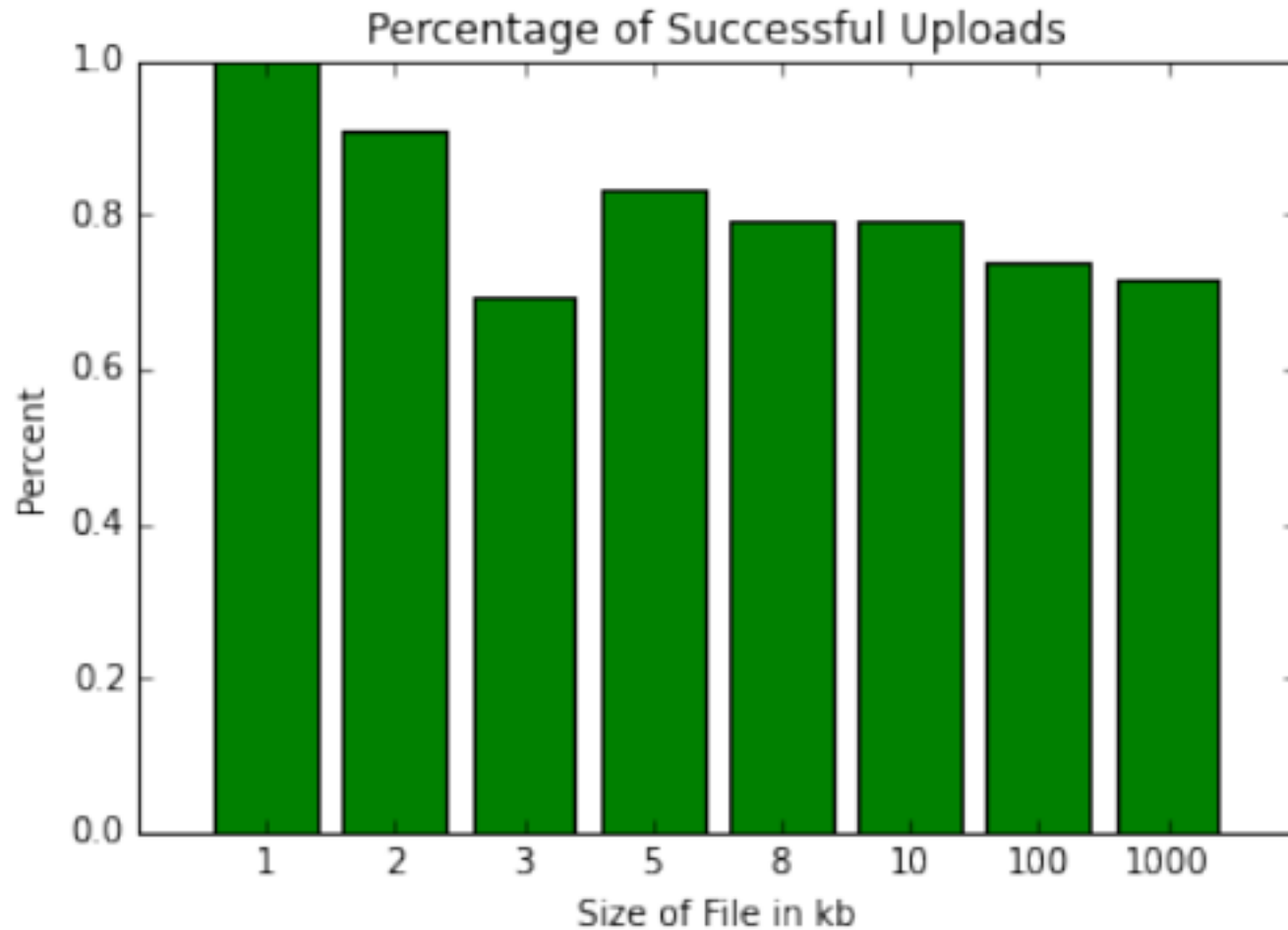

Generally – get about 75% throughput success

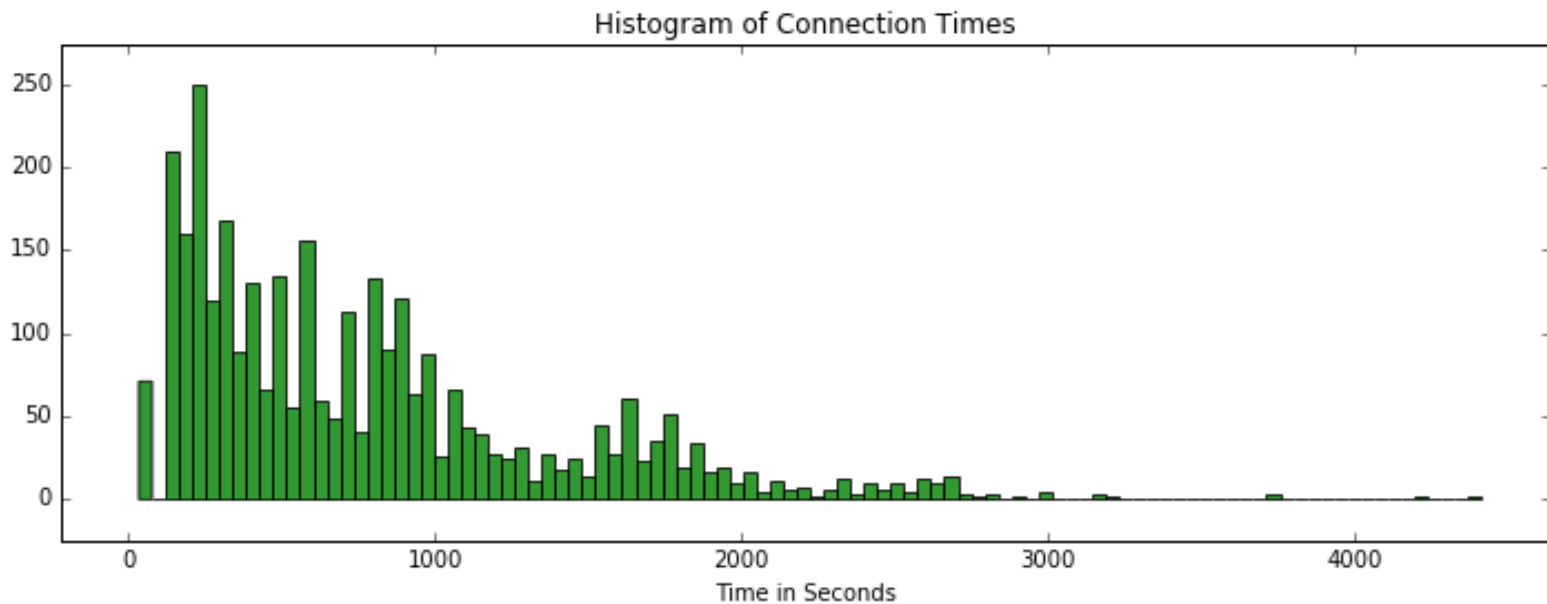

- Horizontal axis is the duration of the connection
- Vertical axis is how many connections terminated in that interval
- 25% of all connections lasted less than five minutes
- Median connection time was just over ten minutes
- 25% of all connections lasted longer than eighteen minutes

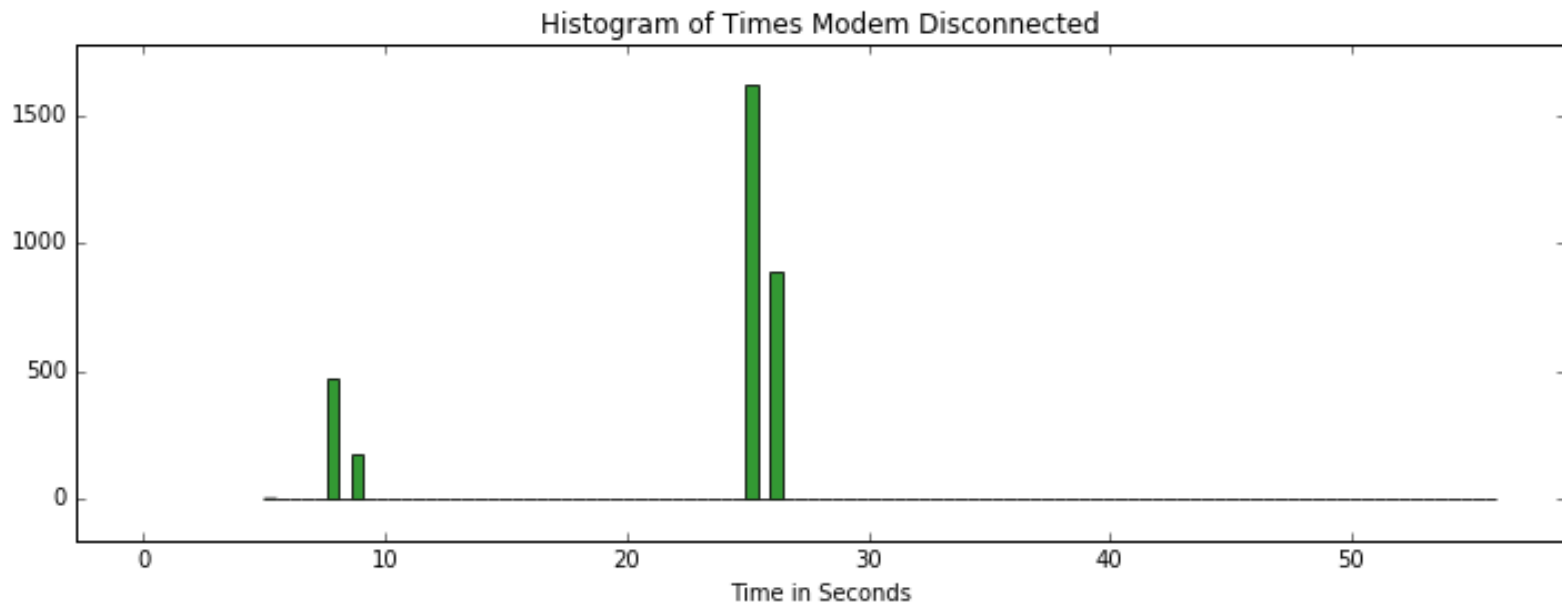

measuring how long until we decided to initiate another call; usually 25 minutes, but not infrequently eight or nine minutes. This graph does not tell us what the next state is, but I **think** it should usually be the "calling" state.

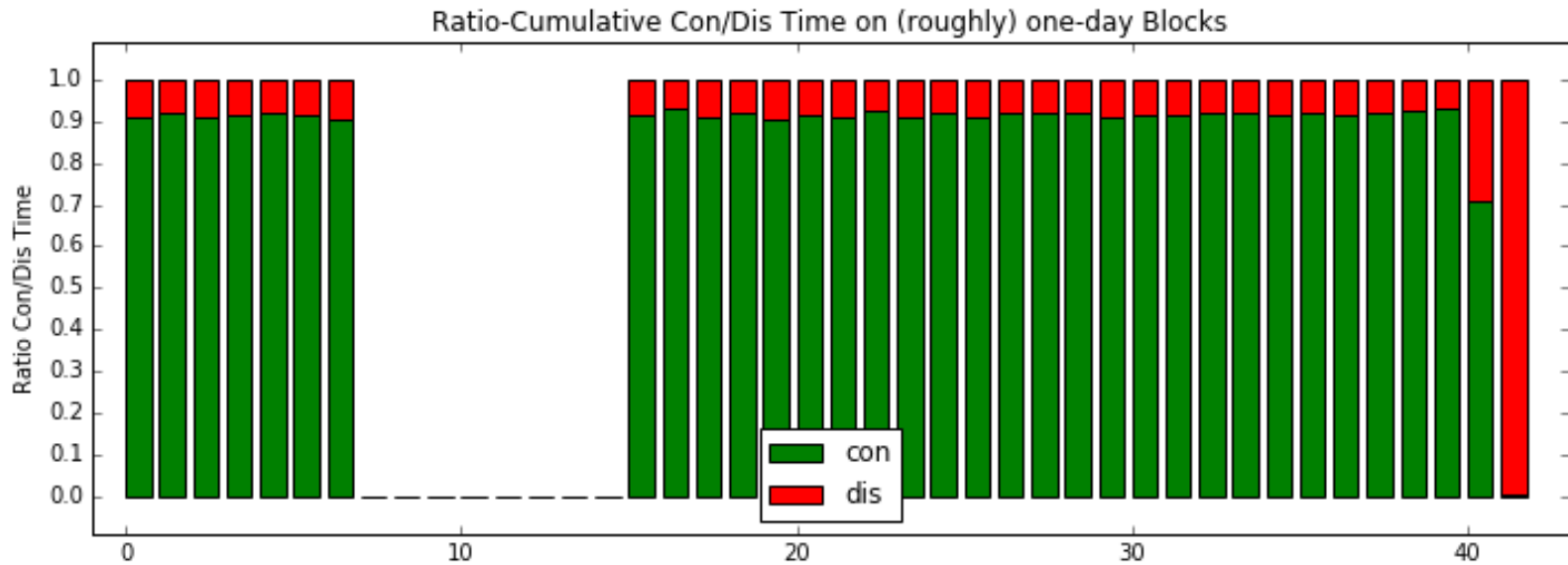

what fraction of the time we spent connected and what fraction we spent disconnected, which aside from the week where we had no data and the last day, we are disconnected 10% to 12% of the time.

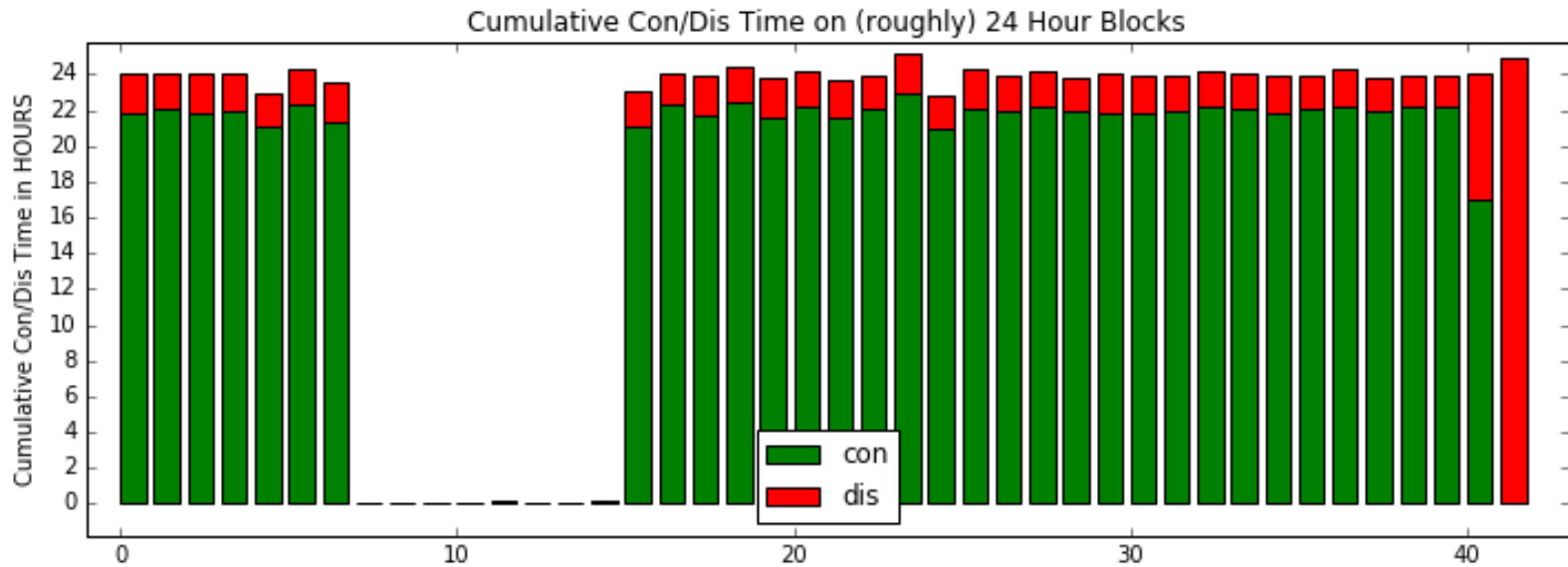

similar to the above, but shows the data as "accumulated hours" -- this exposes the ragged top due to the fact that the total duration of each connection is being accumulated into the bar that contains the start of the connection. Shows that we accumulated about two hours per day of not being connected

Backup