



Integrating CCSDS Electronic Data Sheets into Flight Software

Jonathan Wilmot
Jonathan.J.Wilmot@NASA.gov

CCSDS Electronic Data Sheet Definition

- An Electronic Data Sheet (EDS) is a formal specification of a device, system, or software interface in a machine readable format
 - Unambiguous and machine verifiable specification
 - Delivered with the device, system, or software
 - It is not an Interface Control Document (ICD) in that it does not specify how a system or mission will use the device or software
- EDS specifies black box view of interfaces
 - Data formats, conversions, limits, exchange protocols, and state machines, ...
- A CCSDS Spacecraft Onboard Interface Services (SOIS) EDS (SEDS) is an EDS defined using the SOIS Dictionary of Terms and the SOIS EDS XML schema
 - Electronic Data Sheets and Common Dictionary of Terms - Overview and Rationale (Green 870.1)
 - XML Specification for Electronic Data Sheets for Onboard Devices and Software Components (Magenta 876.0)
 - Specification for Dictionary of Terms for Electronic Data Sheets for Onboard Components (Blue 876.1)
 - SEDS schema and dictionary of terms are keep in SPACE ASSIGNED NUMBER AUTHORITY(SANA) REGISTRY <http://sanaregistry.org/r/sois/sois.html>

Device and Software Component EDS

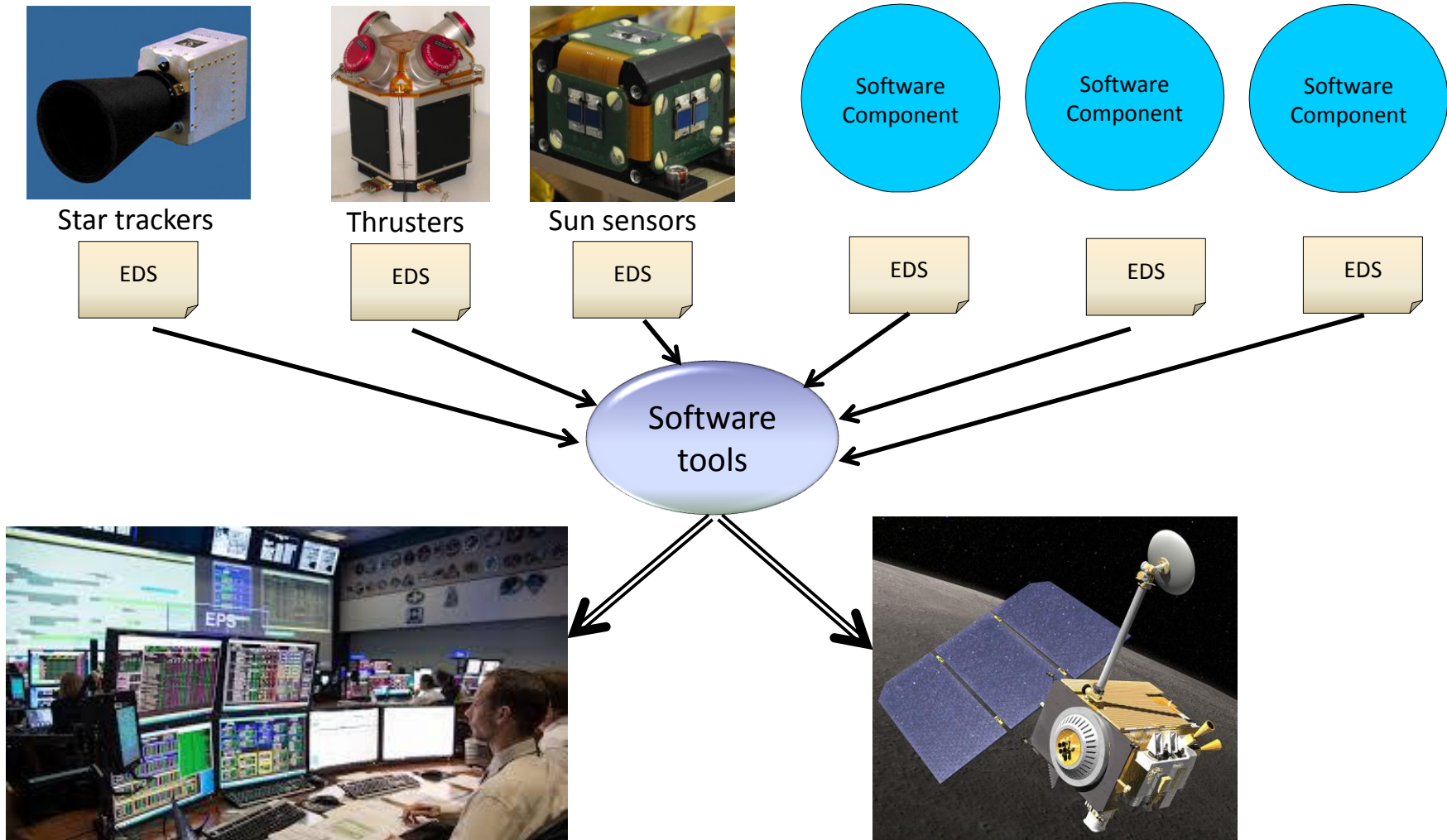

Vision: device manufactures provide an EDS with each component

Use in Early Mission Design

- Automated tools used for device selection based on mission parameters
 - Orbit, lifetime, performance...
- Automated tools can generate system specs and cost estimates
- Mission designers review specs and cost estimates and adjust mission parameters
- US Air Force Research Lab (AFRL) created prototype tools for this use case, Spacecraft Plug and Play (SPA)

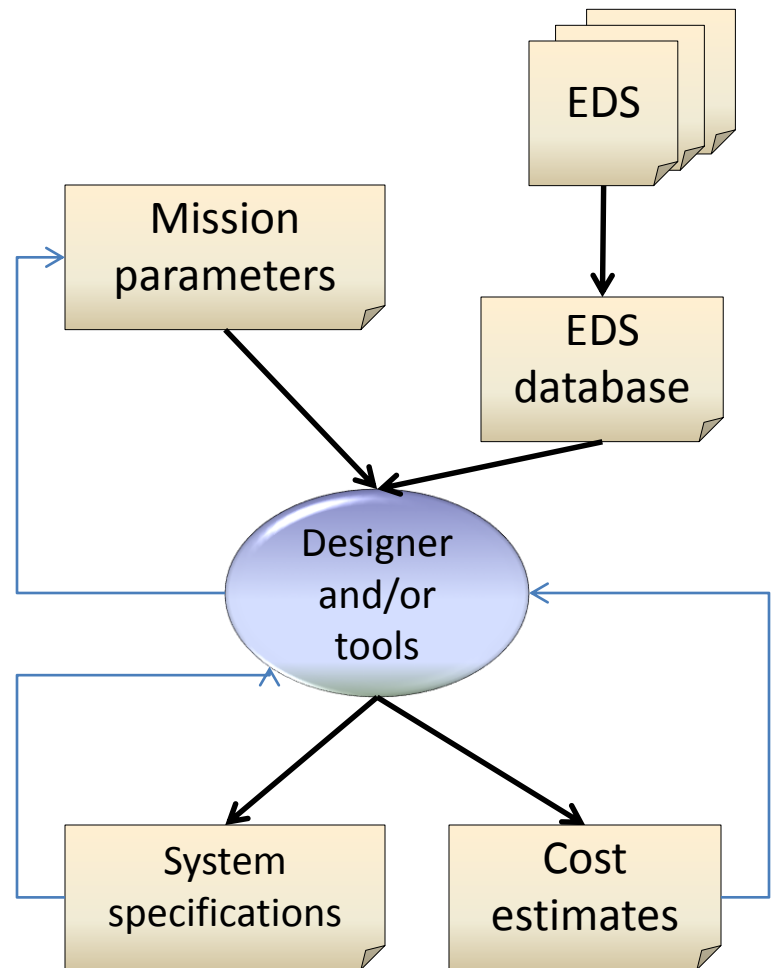

Development and Operations Use Cases

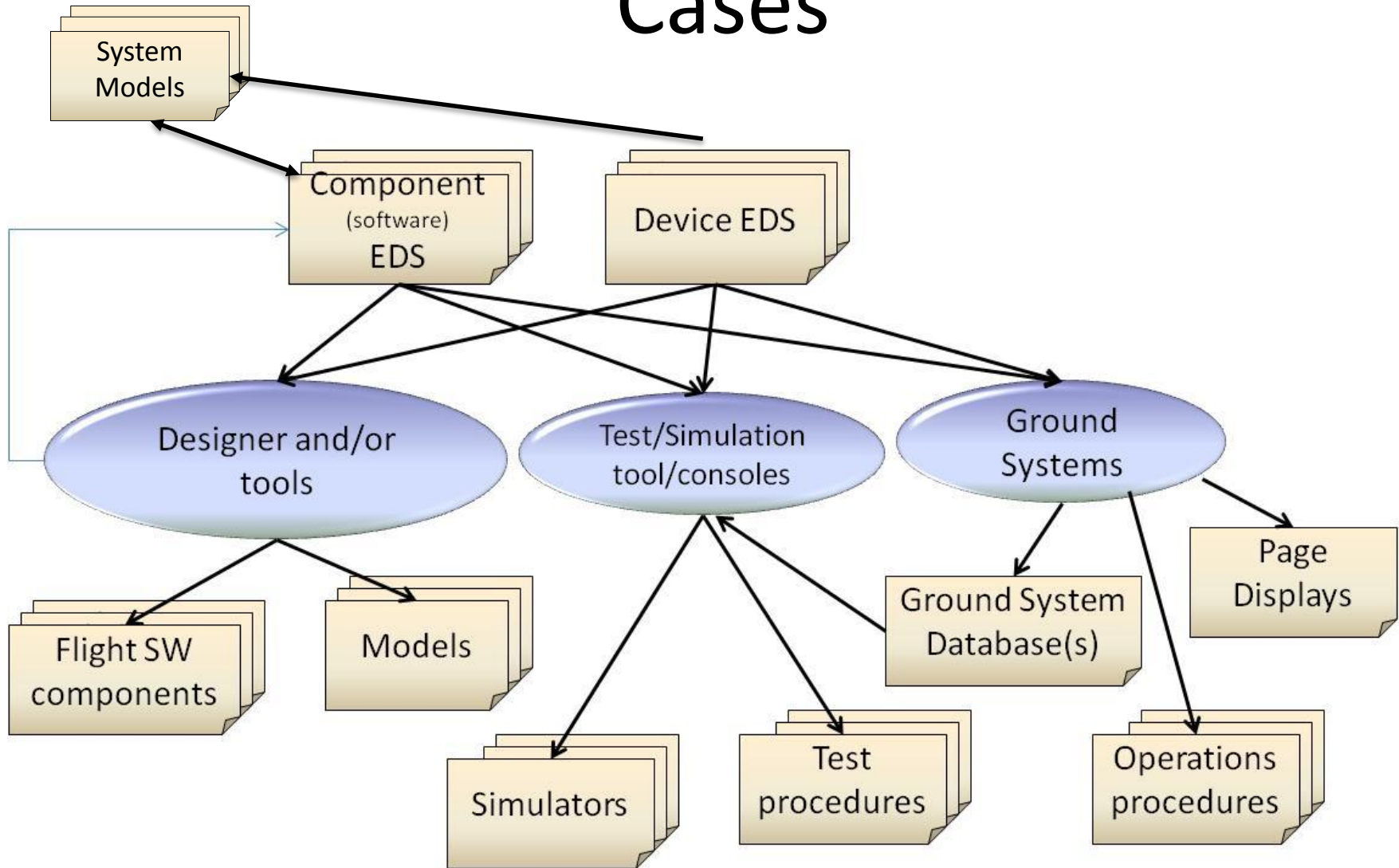



Existing and Upcoming/proposed Tools

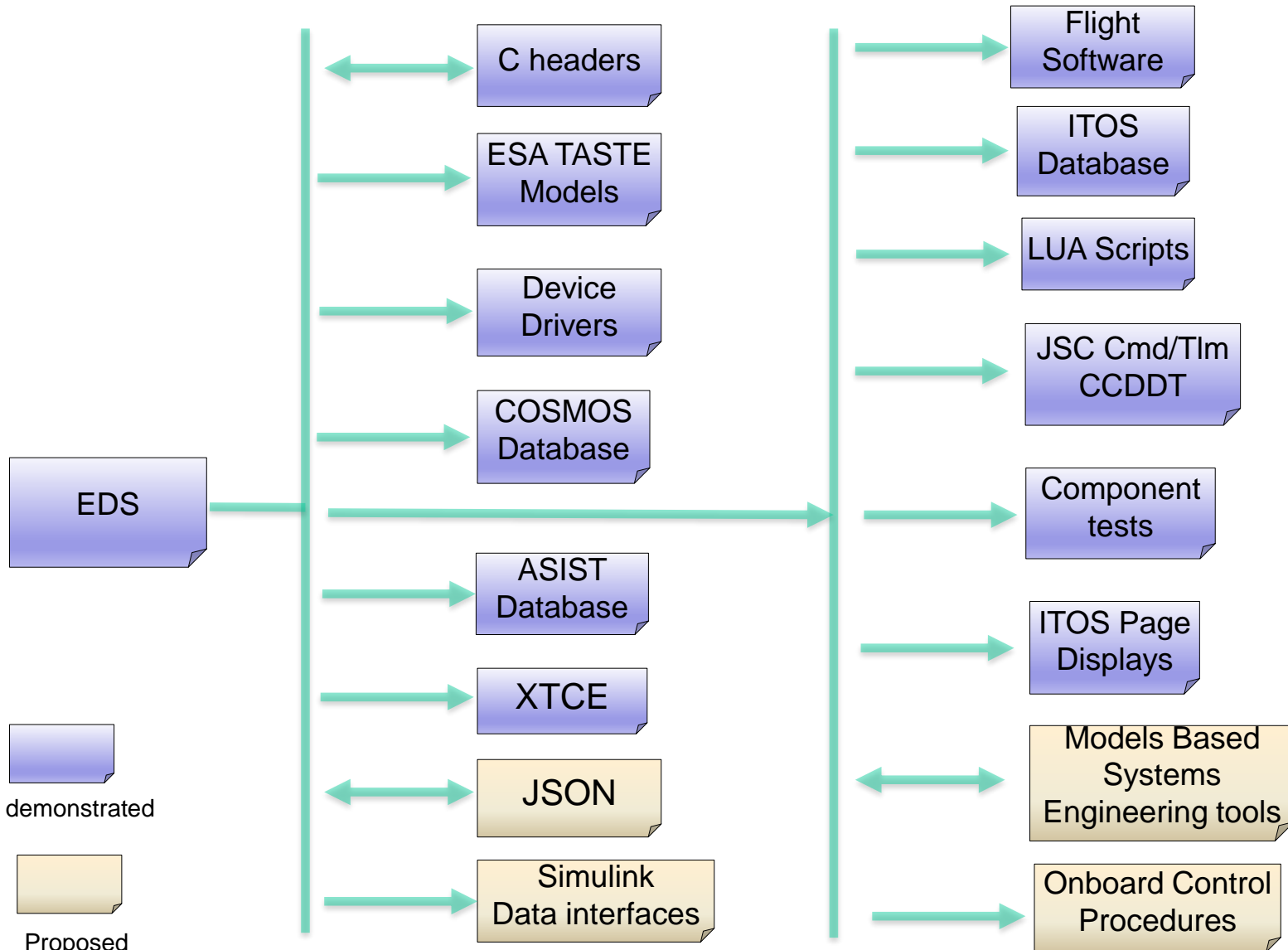



EDS Use in NASA's core Flight System (cFS) software

**Free, open source, reliable
flight software**

cFS Overview

- **Layered Architecture**
- **Pub/Sub Messaging**
- **Common Services**
 - **Executive**
 - **Time**
 - **Message Bus**
 - **Events**
 - **Tables**
 - **Files**
- **Distributed systems**
- **Time/Space Partitions**

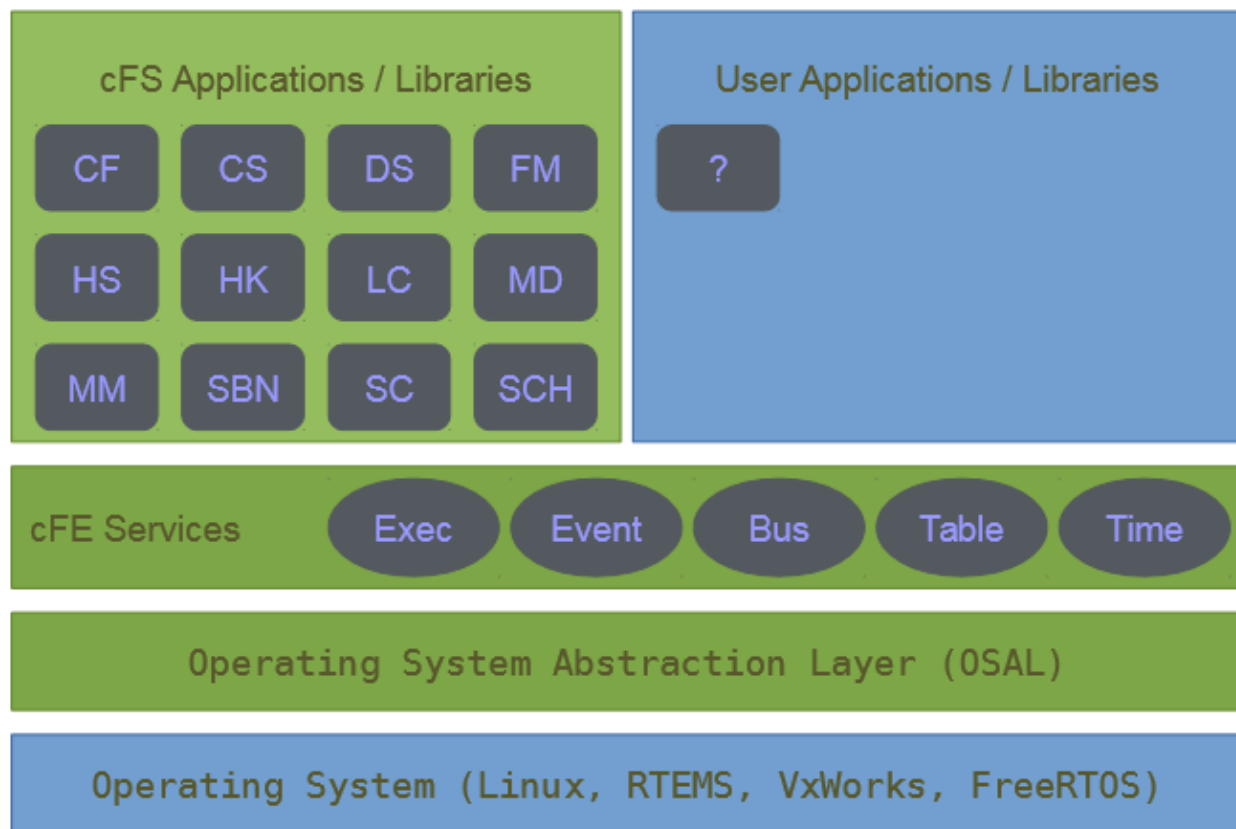

Applications and libraries can be stopped, restarted, removed, and reloaded dynamically at run-time

Go get it at <https://cfs.gsfc.nasa.gov/>

cFS Software Component



- Each cFS component will have an associated SEDS
 - cFS AppStore will include both
 - Include in next release(TBR) of cFE and selected applications
- SEDS specifies the data formats, conversions, limits, commands, telemetry, and exchange protocols in terms of the cFS Software Bus
 - Protocols are in terms of command and response state machines
- The SEDS will be included in the component directory structure and be Configuration Managed with the component

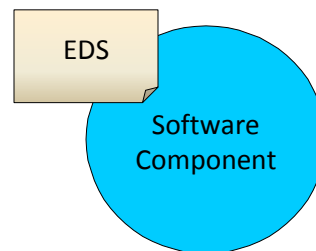

EDS Is In Reference To What?

- An EDS is in reference to the “on the wire” spec from the point of view of the publisher
 - The publisher should be able to DMA the in memory representation to the network interface
 - A CFS Component EDS is written in terms of Big (Network) Endianness
 - Tools must be developed to convert to other architectures

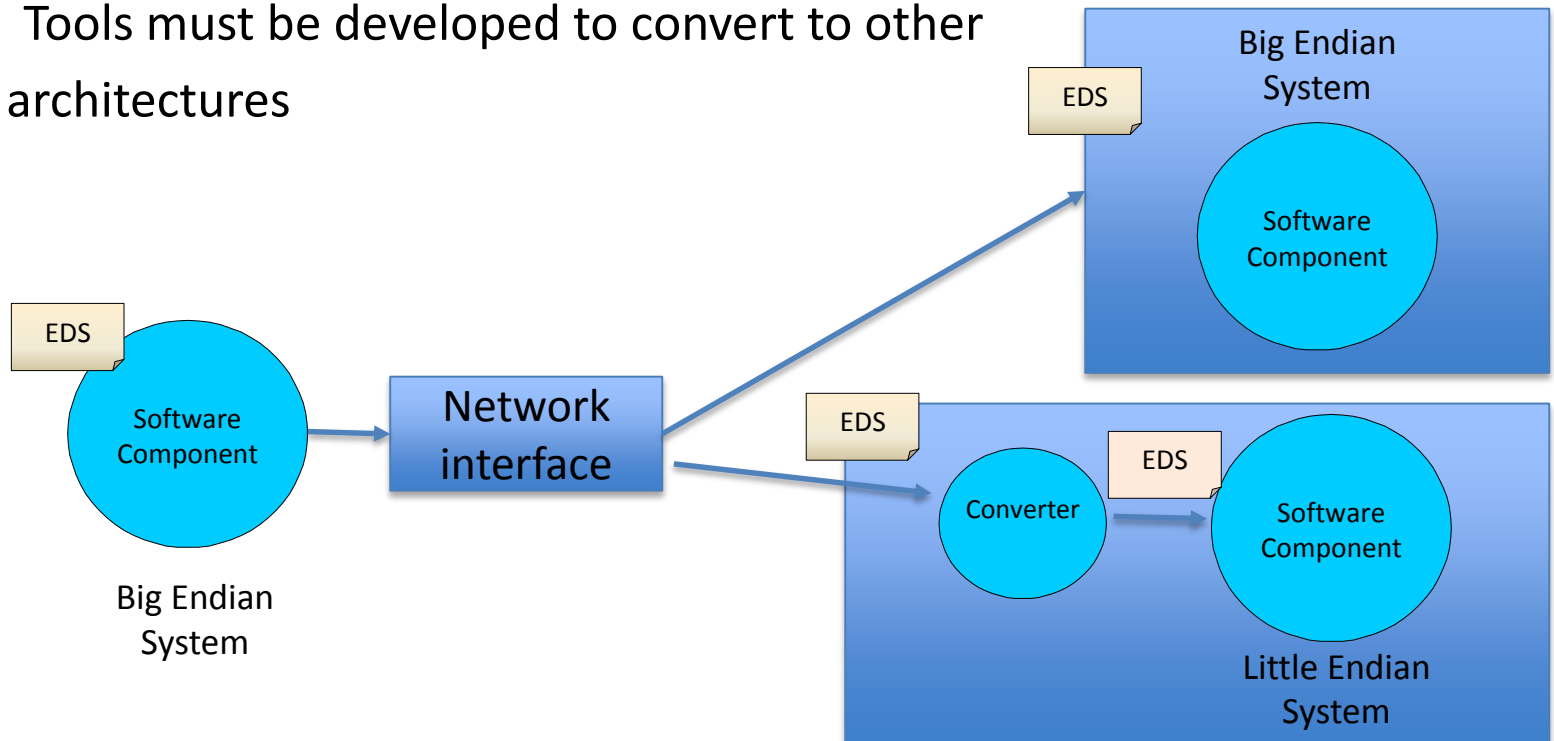

Standardization along Communication Stack

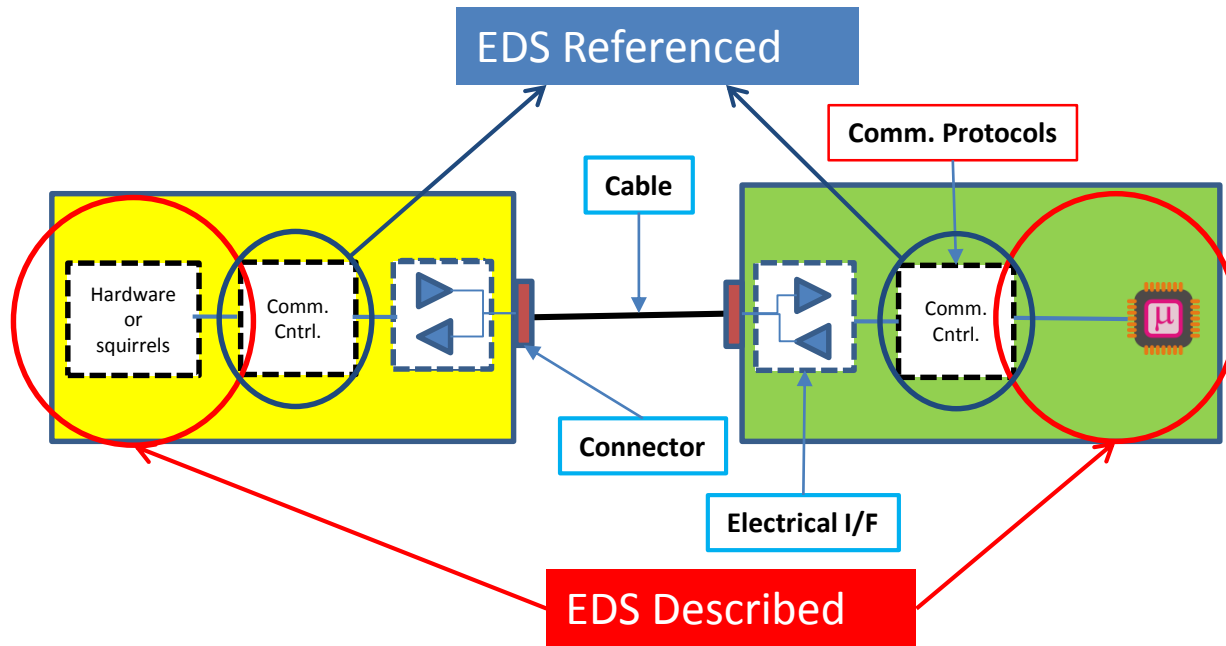

Function	Example
Software tasks communication (software architecture specific)	publish/subscribe, etc.
Data representation (EDS describes)	Counts to units conversion
Software drivers (EDS describes)	Hardware-to-software I/F
Box-to-Box comm. Protocols (EDS reference)	SpaceWire; 1553, etc.
Conn./cable & electrical I/F	9 pin MDM, Cat5, LVDS

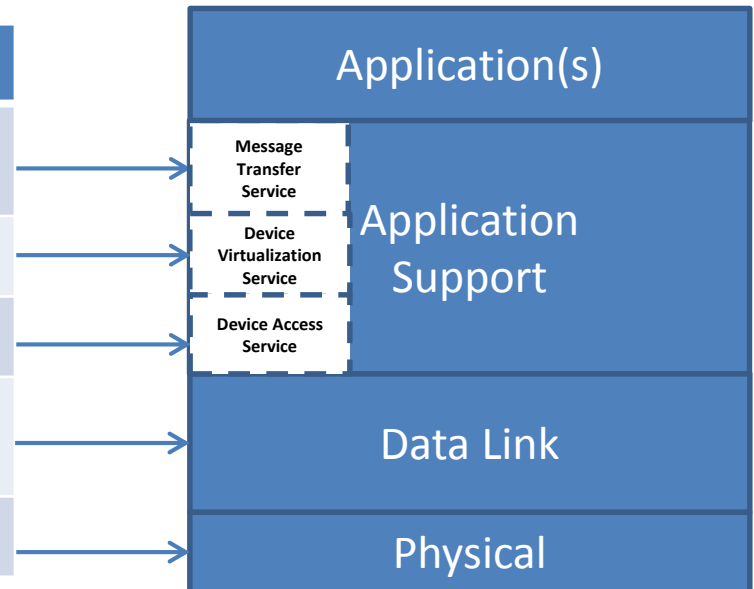

Current cFS View of SEDS End to End

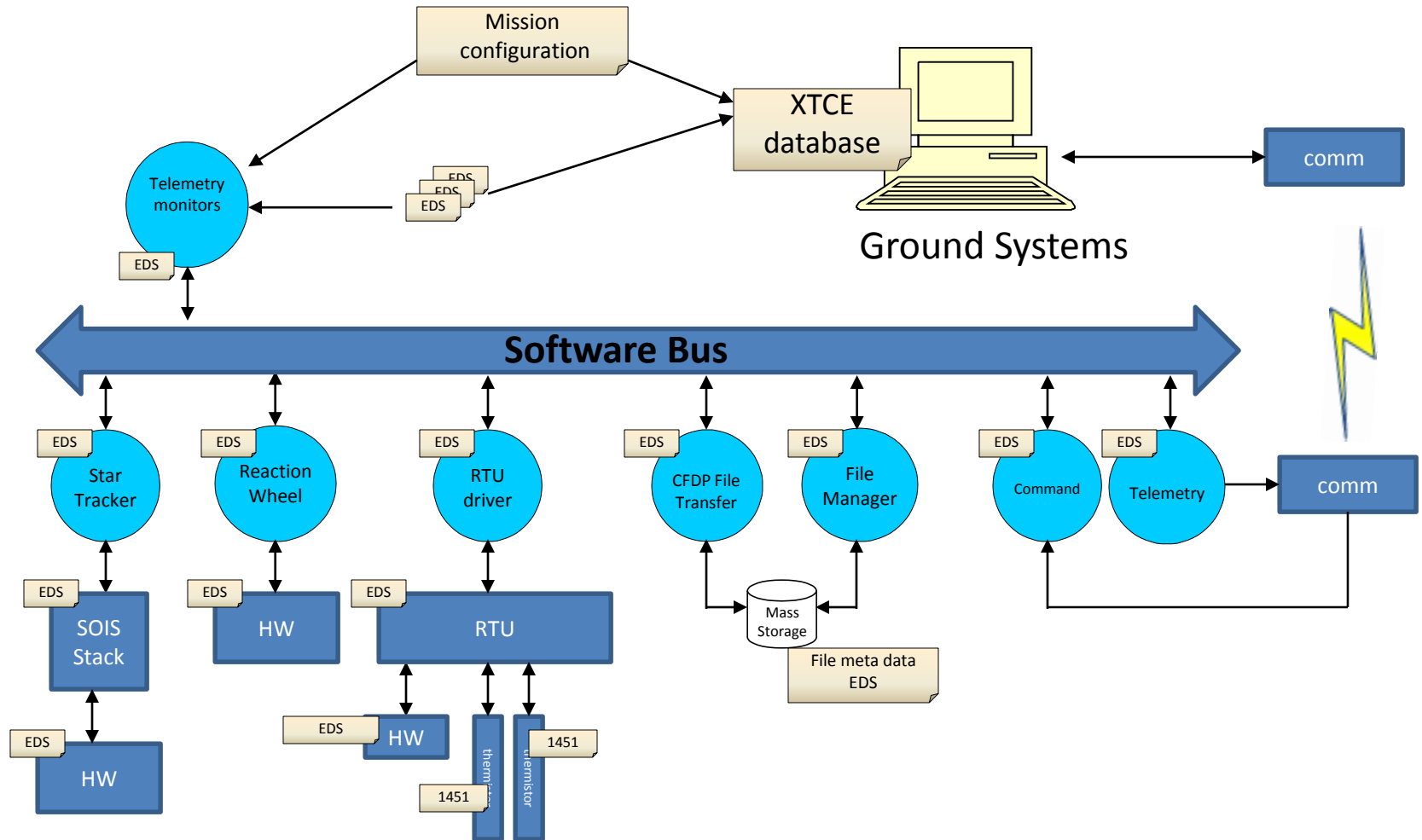

Components and Build Time Parameters



- Each device and software component includes an associated SEDS
- SEDS specifies the data formats, conversions, limits, commands, telemetry, and exchange protocols in terms of the message bus and/or hardware interface
- Some parameter values in the message packet EDS are determined at build time
 - The original component EDS author does not know these values
 - Values are defined in mission deployment files
 - The values will be set by a tool that reads the mission files and creates a software component header file at build time
 - The EDS Schema has mechanisms for this

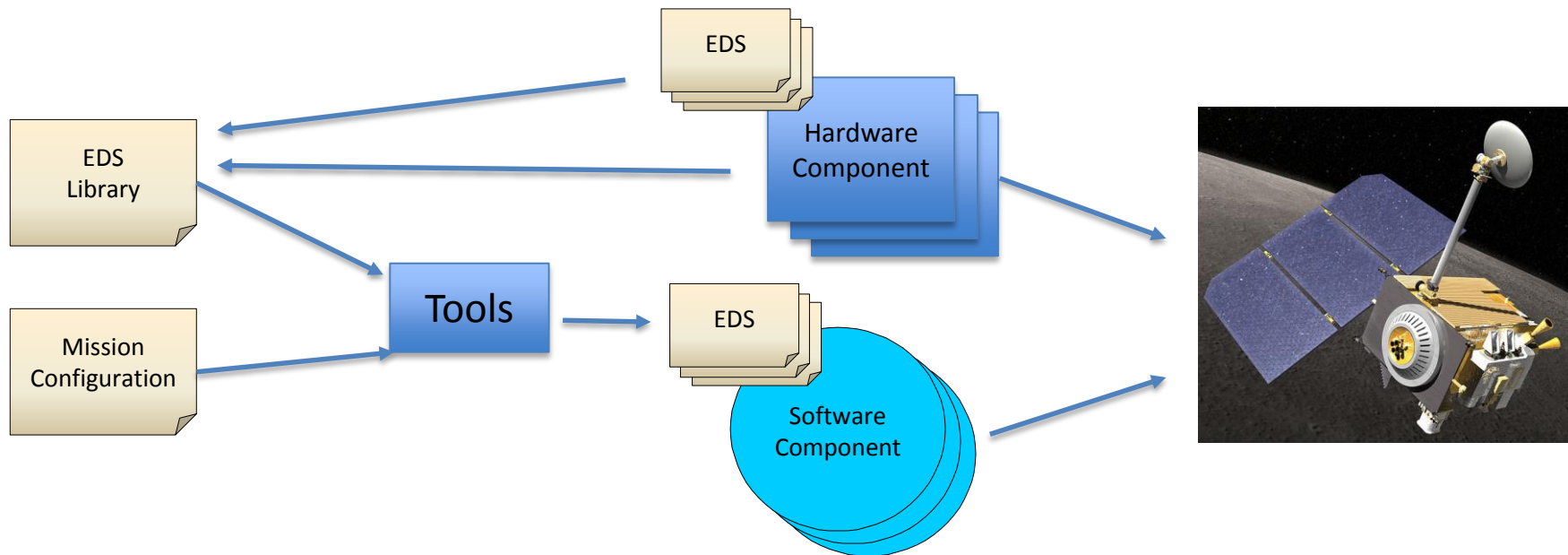

CCSDS SOIS EDS provides a standard mechanism to exchange interface & data definitions and automate many aspects of system development

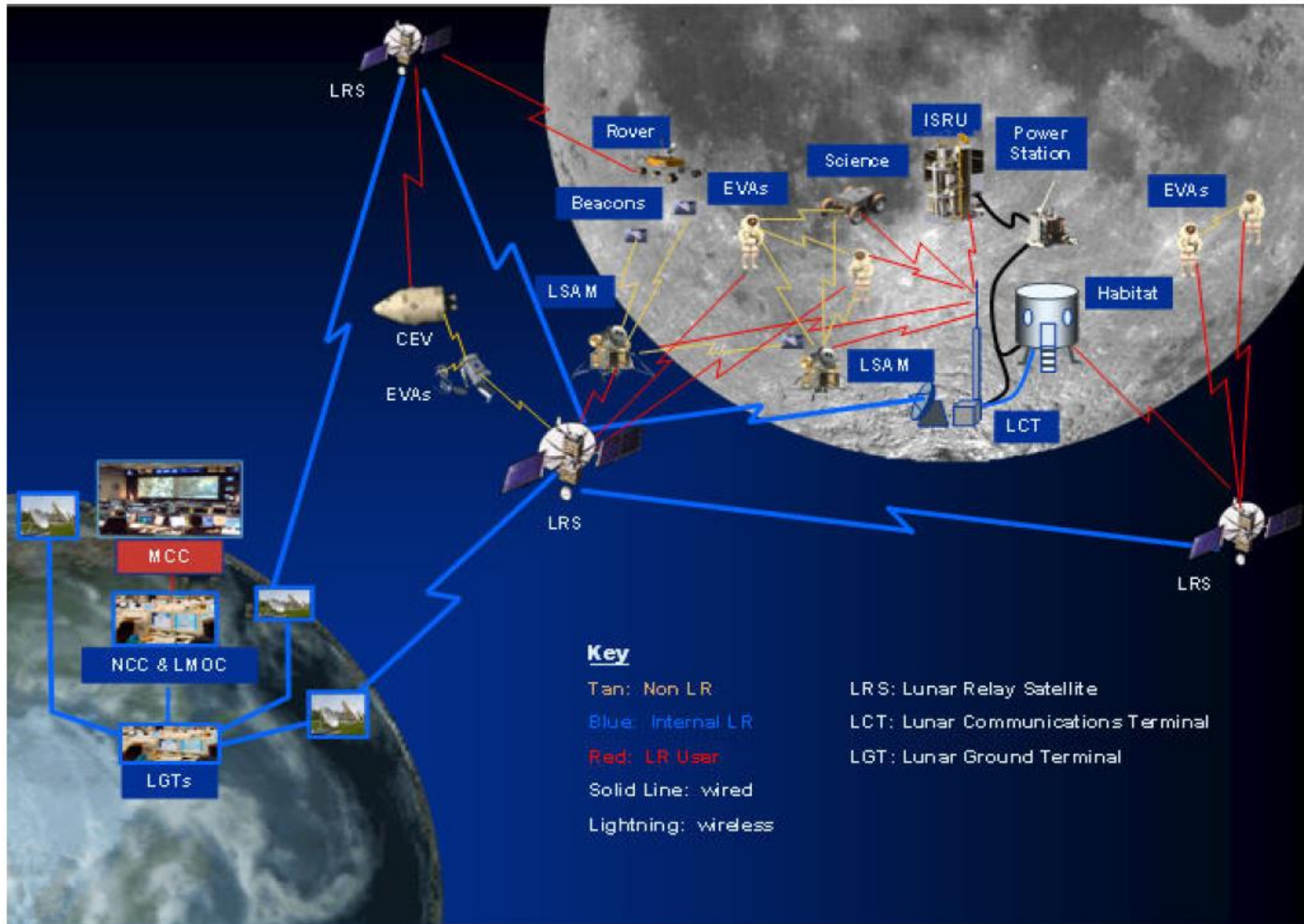

Acronyms

AFRL	Air Force Research Lab
ASIST	Advanced Spacecraft Integration and System Test
CCDDT	cFS Command & Data Dictionary Tool
CCSDS	Consultative Committee for Space Data Systems
cFS	Core Flight System
COSMOS	Ball Aerospace User Interface for Command and Control of Embedded Systems (not a acronym)
EDS	Electronic Data Sheet
ESA	European Space Agency
ITOS	Integrated Test and Operations System
JSON	JavaScript Object Notation
Lua	embeddable scripting language (not a acronym)
NASA	National Aeronautics and Space Administration
SEDS	SOIS Electronic Data Sheet
SOIS	Spacecraft Onboard Interfaces Services
SPA	Space Plug and Play Avionics
TASTE	The Assert Set of Tools for Engineering
XML	eXtensible Markup Language
XTCE	XML Telemetric & Command Exchange
xTEDS	extensible transducer electronic data sheets

Thank You.

Questions?