



Overview of NASA Electrified Aircraft Propulsion Research for Large Subsonic Transports

Ralph H. Jansen, Dr. Cheryl Bowman, Amy Jankovsky, Dr.
Rodger Dyson, and and James L. Felder

NASA Glenn Research Center, Cleveland, Ohio, 44135

Introduction



- Vision for large aircraft with Electrified Aircraft Propulsion
- Aircraft System Studies
- Power research: Electric machines and converters
- Materials
- Test Facilities
- Emerging research areas: Turbine integration, Boundary Layer Benefits
- Conclusion

Motivation



- NASA is investing in Electrified Aircraft Propulsion (EAP) research to improve the fuel efficiency, emissions, and noise levels in commercial transport aircraft
- The goal is to show that one or more viable EAP concepts exist for narrow-body aircraft and to advance crucial technologies related to those concepts.
- Viability in this context implies that concept of operation benefits have been identified for fuel burn, energy consumption, emissions, and noise metrics. Reasonable development approaches for key technologies have been identified.

NASA Evolution of Thought



**GREATLY REDUCED TECHNOLOGY NEEDS ENABLE
NEAR TERM FLIGHT FULL SCALE DEMO**



Fuselage: HWB
 Propulsion: Fully distributed
 Power Distribution: 50MW,
 Superconducting, 7500V, FLIGHT
 CRITICAL
 Power Source: Turbo generators
 Infrastructure: Same air traffic



Fuselage: Tube and Wing
 Propulsion: Partially distributed
 Power Distribution: 3MW, 1,200V,
 not flight critical
 Power Source: Turbo generators
 Infrastructure: Same air traffic,
 airports

**EXTREME PAI, BATTERY POWERED,
LOW COST FLIGHT DEMO**



Fuselage: Tube and Wing
 Propulsion: Fully distributed
 Power Distribution: 1MW, 600V,
 FLIGHT CRITICAL
 Power Source: Batteries to 200miles,
 fuel to 500 miles
 Infrastructure: Underutilized small
 airports, new charging stations



Fuselage: Fixed Wing VTOL
 Propulsion: Fully distributed
 Power Distribution: <1MW, <600V,
 FLIGHT CRITICAL
 Power Source: Batteries to 100 miles
 Infrastructure: Advanced air traffic,
 reduced or no pilot, new infrastructure

**NEAR/ MID
TERM**

GOAL:
 2035 EAP EIS
 for Single Aisle



Activities:
 2025 RJ or SA X-Plane
 Enabling R&D

GOAL:
 New Aircraft
 Market



Activities:
 Fixed Wing VTOL X-Plane
 Enabling R&D

**MID/FAR
TERM**

Small and Large
 come together with
 full DEP and on-
 board electrical
 storage

Single Aisle Aircraft Level System Studies



Study	Pax	Speed, Mach	Airframe	EAP	Electrical power, MW	Propulsion
NASA STARC-ABL	154	0.8	Tube and wing	Partial turboelectric	2 to 3	2 turbofans and 1 aft motor- driven fan
Boeing SUGAR Freeze	154	0.7	Tube and truss brace wing	Partially turboelectric (fuel cell)		2 turbofans and 1 aft motor- driven fan
NASA N3-X	300	0.84	Hybrid wing body	Turboelectric	50	16 aft motor- driven fans
ESAero ECO- 150	150	0.7	Tube and split wing	Turboelectric		16 wing motor- driven fans
Boeing SUGAR Volt	154	0.7	Tube and truss brace wing	Parallel hybrid electric	1.3 or 5.3	2 motor-assisted turbofans
Rolls-Royce	154	0.7	Tube and wing	Parallel hybrid electric	1 to 2.6	2 motor-assisted turbofans
UTRC	154	0.7	Tube and wing	Parallel hybrid electric	2.1	2 motor-assisted turbofans

Partial Turboelectric



- NASA STARC-ABL: fuel burn reduction 7-12%, same range, speed, airport infrastructure. Same turbine/airframe technology, advanced 2-3MW power system, BLI, turbogenerator integration

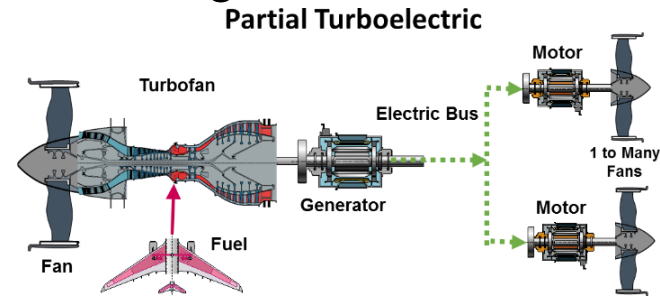

- Boeing SUGAR Freeze: fuel burn reduction 56% for 900 mile mission, utilizes a truss-braced wing combined with a boundary-layer ingesting fan in an aft tail cone to maximize aerodynamic efficiency. The aft fan is powered by a solid oxide fuel cell topping cycle and driven by a superconducting motor with a cryogenic power management system

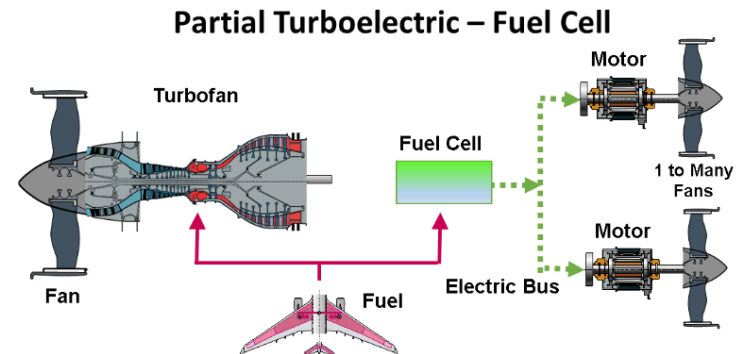

Fully Turboelectric



- NASA N3-X: fuel burn reduction 70%, same range, speed, airport infrastructure. Technology: Hybrid Wing Body, Fully distributed 50MW, Superconducting, 7500V, power system

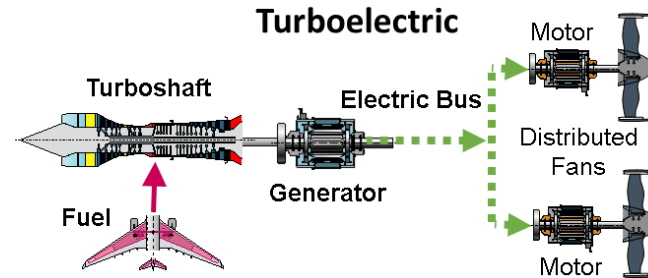

- Empirical Systems Aerospace ECO-150R: Depending on the underlying technology assumptions performance ranges between matching and significantly exceeding current aircraft fuel burn. Technology considered ranges from superconducting electrical machines cooled with liquid hydrogen to conventional machines at various technology levels. The ECO-150R, which utilizes midterm electrical machine technology.

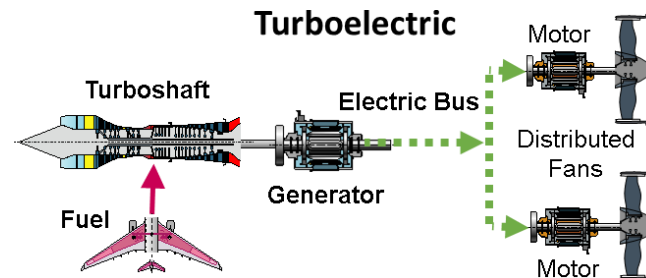

Parallel Hybrid Concepts



- Airframe/propulsion remains relatively decoupled

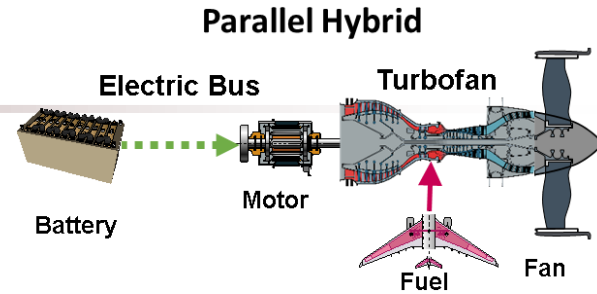

Boeing Sugar Volt

- Parallel hybrid, 150 passenger, 900 nm
- 1.3 and 5.3 MW machines considered
- Fuel off-loaded 750 W-hr/kg batteries charged from grid
- 60% fuel burn reduction

UTRC hGTF – On-going, optimized geared turbofan engine for cruise by adding boost power for take off and climb

- Parallel hybrid, 150 passenger, 900 nm
- 2.1 MW machines, 1000 W-hr/kg batteries
- 6% reduction in fuel burn and 2.5% reduction in energy usage

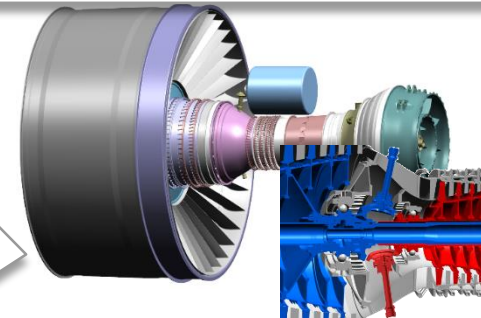

Low Spool
High Spool

R-R LibertyWorks EVE – On-going, parametrically optimized engine with hybrid climb & cruise segments

- Parallel hybrid, 150 passenger, 900 nm
- 28% reduction in fuel burn for a 900-nm mission
- Up to a 10% total energy reduction for a 500-nm
- Optimizing for minimum fuel usage predicts an 18 percent reduction in total fleet fuel usage.

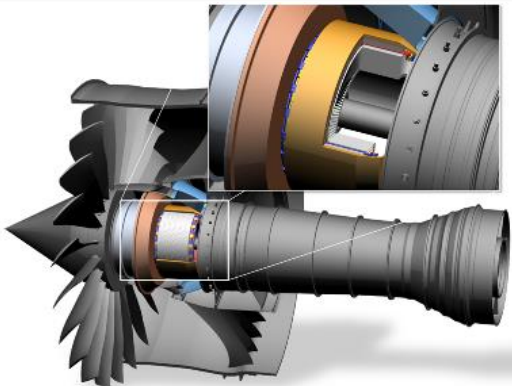

Electric Machines Research



- Motors and/or generators (Electric machines) are needed on all electrified aircraft.
- NASA is sponsoring or performing work to achieve power densities 2-3 times the state of the art for machines in the MW or larger class.
- Three major machine types are being developed: permanent magnet, induction, and wound field

	Continuous power rating, MW	Specific power goal, kW/kg	Efficiency goal, %	Motor type	Speed	Nominal dimensions
University of Illinois	1	13	>96	Permanent magnet	18,000	Cylinder 0.45 m by 0.12 m
Ohio State University	2.7	13	>96	Induction	2,500	Ring 1.0 m by 0.12 m
NASA Glenn Research Center	1.4	16	>98	Wound field	6,800	Cylinder 0.40 m by 0.12 m

Topology

- 1.0 MW permanent magnet synchronous motor with a performance goal of 13 kW/kg and efficiency of >96 percent
- Outside rotor with a composite overwrap and permanent magnets.
- Relatively high pole count and fundamental frequency.
- Extensive analysis and subcomponent testing have been done to optimize the electromagnetic, structural, and thermal design.

Aircraft Level Integration

- The motor integrated with the Rolls-Royce LibertyWorks EVE engine concept is shown
- The motor design is being coordinated with a design and build effort at the University of Illinois to produce a multilevel inverter, which potentially could be used to drive the motor.

Validation

- Form wound litz wire fabrication and thermal testing
- full-speed rotor validation testing was done to ensure the best possible permanent magnet/carbon fiber overwrap rotor design

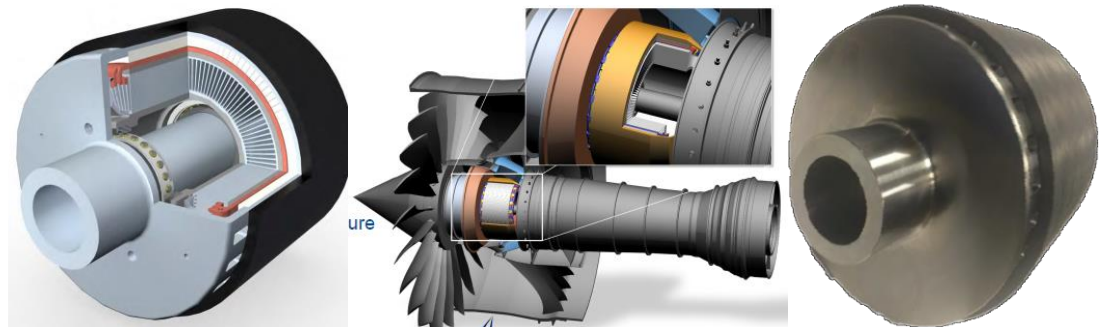

Ohio State University Induction Machine



Topology

- 2.7 MW ring induction motor with a performance goal of 13 kW/kg and efficiency of >96 percent
- Relatively high pole count and fundamental frequency.
- The Variable Cross-Section Wet Coil (VCSWC) technology utilizes direct fluid cooling on a tape conductor, which is the width of the slot in the active area, and widens at the end turns to maximize heat transfer and therefore current density.

Aircraft Level Integration

- The 10 MW motor integrated with a turbofan is shown

Validation

- Motor 1 (300kW) shown validated cooling path and stator manufacturing
- Motor 2 (1MW) validates tape coil fabrication and stator integration
- Motor 3 (2.7MW) validates performance

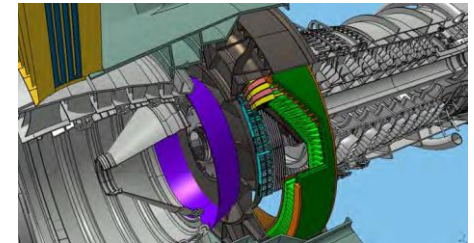
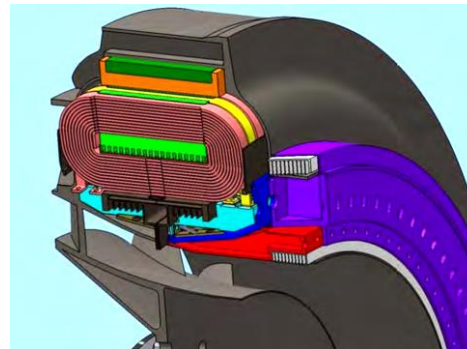

NASA High Efficiency Megawatt Motor (HEMM)

Topology

- HEMM is a 1.4MW wound field synchronous motor with a stretch performance goal of 16 kW/kg and efficiency of 99 percent
- The motor combines a conductively self-cooled, DC superconducting rotor windings with a slotless stator, allowing the motor to achieve exceptional specific power and efficiency without inheriting the external cooling weight penalty commonly attributed to superconducting machines.

Aircraft Level Impact

- Fuel Burn: STARC-ABL studies have shown that increasing motor efficiency from 96% percent (state-of-the-art) to 99% will reduce fuel burn an **additional 2 percent**
- Thermal System: Improving from 96% efficiency to 99% will reduce the amount of waste heat and related thermal management systems by a factor of 4.

Key Features

- Uses standard aircraft cooling systems
- Direct drive at optimal turbomachinery speeds (no gearbox)
- Can be shut off if fault occurs (wound field)

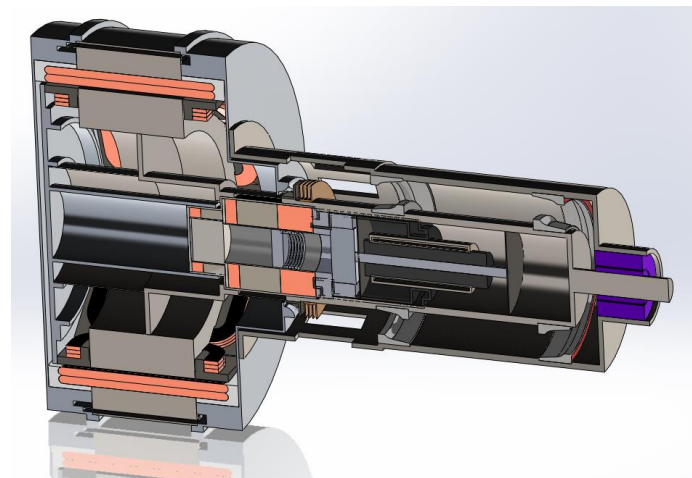

Converter Research



- Power converters are an essential component in most EAP aircraft concepts, as they are used to convert from ac to dc power, or vice versa
- NASA is sponsoring or performing work to achieve power densities 2-3 times the state of the art for converters in the MW or larger class.
- Silicon carbide and gallium nitride converters are being developed with conventional cooling as well as a cryogenically cooled converter

	Continuous power rating, MW	Specific power goal, kW/kg	Efficiency goal, %	Topology	Switch material	Cooling
General Electric	1	19	99	3 level	SiC/Si	Liquid
University of Illinois	0.2	19	99	7 level	GaN	Liquid
Boeing	1	26	99.3		Si	Cryogenic

General Electric Silicon Carbide Inverter



Topology

- GE inverter implements SiC switch technology, using a 2400 V dc input and providing a three-phase output capability, generating an output fundamental frequency ranging between 1 to 3 kHz
- The design topology for this inverter is a three-level Active Neutral Point Clamped (ANPC) topology
- GE's 1.7-kW, 500 A, SiC metal oxide semiconductor field effect transistor (MOSFET) dual-switch power modules
- The dc filter sizing is based on DO-160E, Section 21

Performance Goal

- 19kW/kg, 99% efficiency

Validation

- The project culminates in a ground demonstration
- Additional work will be need to validate high voltage operation at altitude

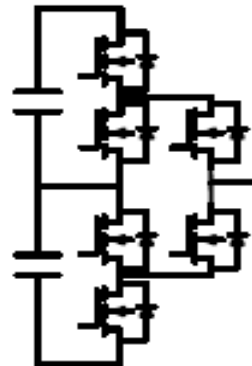

University of Illinois Gallium Nitride Inverter



Topology

- The University of Illinois is building a 200-kW, multilevel, flying capacitor topology with gallium nitride power switches that is scalable to a 1-MW system
- The topology employs nine levels and shifts the energy storage used in filtering elements from inductors, which are common to many designs, to capacitors, which have a much higher energy density
- The dc bus voltage will be 1000 V.

Performance Goal

- 19kW/kg, 99% efficiency

Validation

- Prototype power modules have been built and tested resulting in refinements.
- Additional work has been done to show viability at cryogenic temperatures in addition to room temp.

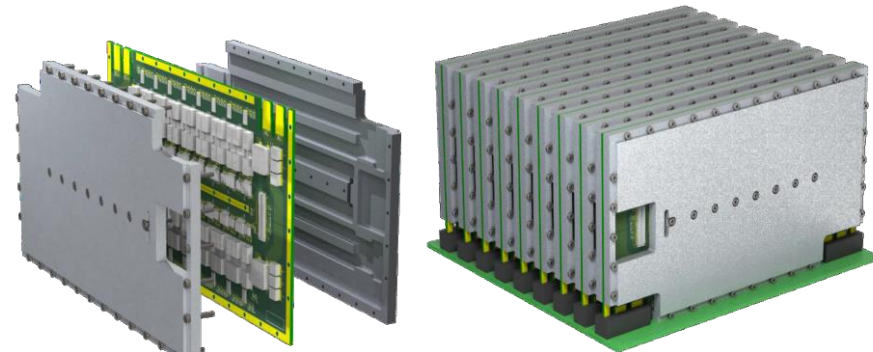
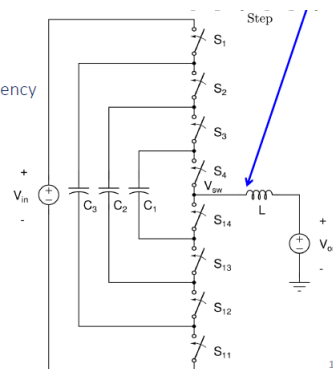

Boeing Cryogenically Cooled Inverter



Topology

- Boeing is developing a cryogenically cooled 1-MW inverter intended to be compatible with liquid natural gas or hydrogen cooling, but the experimental prototype will be cooled by liquid nitrogen.
- Three-level ANPC topology that uses different power switches for the fast and slow switching
- The input dc voltage is 1000 V, and the output frequency is 200 to 3000 Hz
- DC filter meets DO-160 EMI standard.

Performance Goal

- 26kW/kg, 99.3% efficiency

Validation

- A calorimeter was developed that can measure the efficiency of the 200-kW and 1-MW prototypes by the dissipated losses to the liquid nitrogen to better than 0.1 percent of the total power

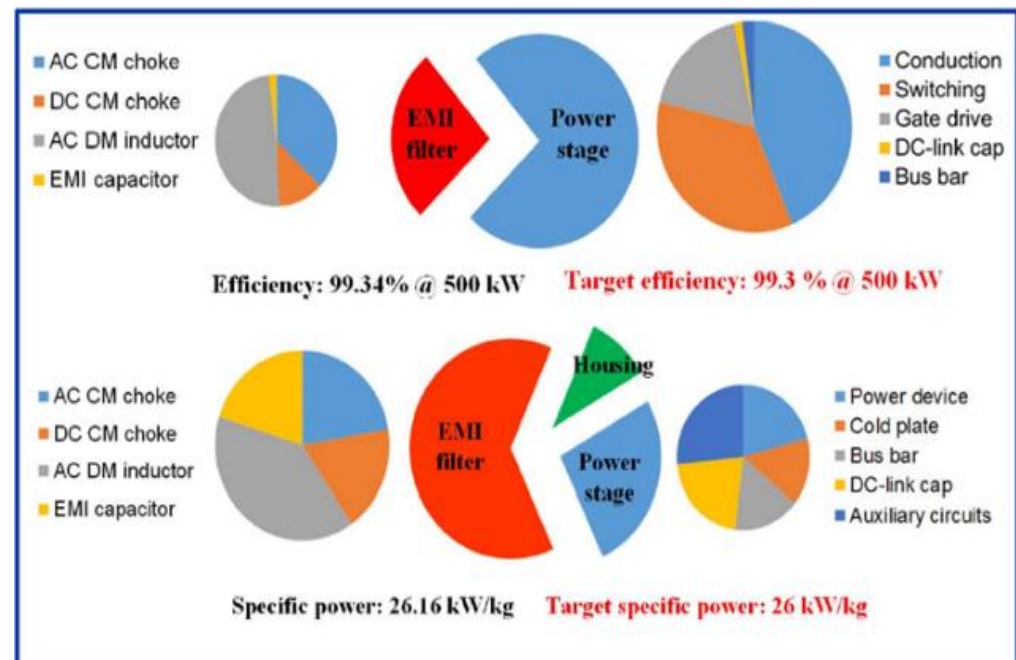

Materials for Electrified Aircraft Propulsion



- New soft magnetic materials – improve performance of converter filters and electric machines
- Insulation – electrical insulation with better thermal transfer to improve electric machine performance
- High-Conductivity Copper/Carbon Nanotube Conductor – approach to reduce the mass of cables
- Superconducting Wire Development – AC superconductors which could be used for electric machines or distribution

NASA Soft Magnetic Materials



- Soft magnetic materials perform key functions in transformers, filter circuits (inductors), and electric machines (motors and generators).
- Unfortunately, they are also a significant contributor to the total weight and losses of such systems.
- NASA is exploring the development, manufacturing, and characterization of a promising new class of amorphous-nanocrystalline composite alloys as well as their use in devices
- A large-scale soft magnetic material spin casting unit originally developed under U.S. Army support has been transitioned to NASA and has been upgraded to increase yield and ribbon quality. This is one of the few facilities in the United States capable of producing magnetic material ribbons wide enough for the development of low power loss and high operational frequency components and devices
- A wide range of magnetic material characterization equipment is available including a custom core loss measurement system, as well as device for measuring magnetic field domains in materials.

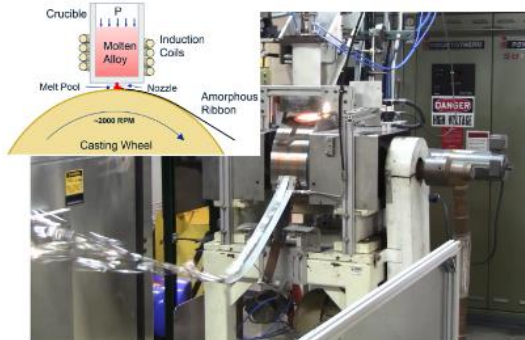

NASA Glenn spin caster

Advanced Air Vehicles Program
Advanced Transport Technologies Project



**A 25-mm by 1.6-km
spin cast ribbon**



**Transformer fabricated
from spin cast ribbon**

Insulation Development



- Although the key role for insulation in electrical machines is electrical isolation, thermal conductivity is equally impactful in electric machine design. Trapped heat increases the electrical resistance of conductors, resulting in lost efficiency, greater fuel consumption, and greater overall thermal management burden.
- Two-dimensional ceramic particles in the microscales and nanoscales are the foundation of many state-of-the-art insulation solutions, and provide many promising approaches for further development. Recent work at NASA Glenn in separating hexagonal boron nitride (hBN) into nanosheets, thus exploring the use of established compounds in a new way

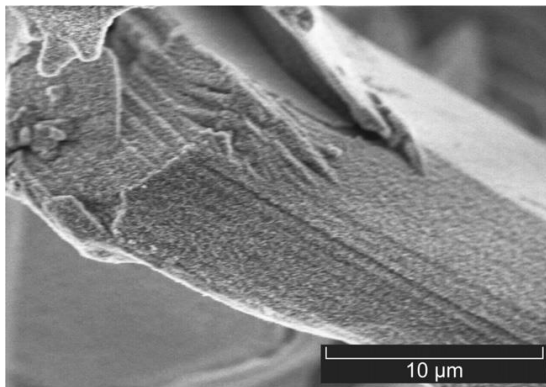

FESEM image of coated hBN platelet

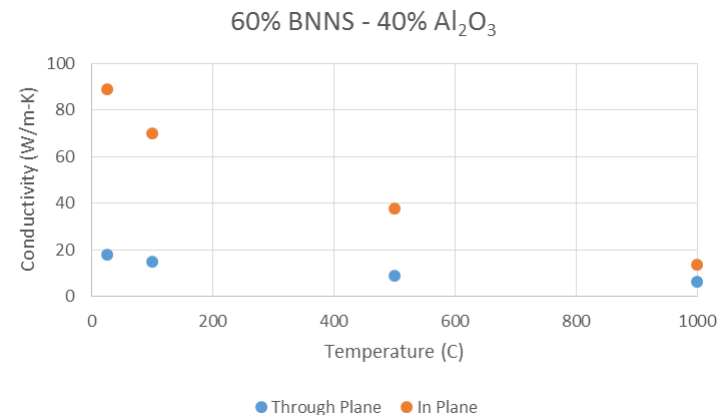

Thermal Conductivity Results

High-Conductivity Copper/Carbon Nanotube Conductor



- The primary conductor requirements in EAP applications require improvement in absolute conduction relative to Cu at operational temperatures (6×10^7 S/m at 20°C) for electric machine applications, and specific conduction better than aluminum (1.4×10^7 S-cc/m-g) for transmission applications
- Graphene and CNT-based composites are being explored by a large number of research efforts in order to meet these challenging conductivity requirements.
- NASA GRC effort – sort metallic / non metallic nanotubes, develop method for coating the metallic nanotube, draw into wire.

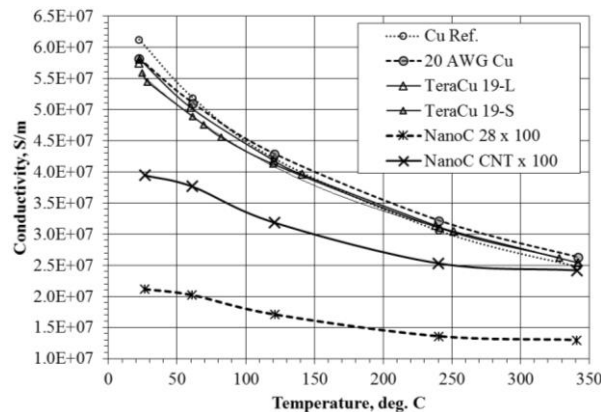

Conductivity for Cu, CNT/Cu, and CNT yarns, ordered top to bottom

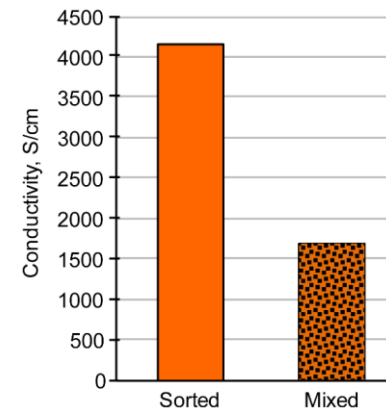

Conductivity of sorted metallic and mixed CNT Buckypaper

Superconducting Wire Development



- Superconducting wires conducting dc incur very low losses
- Superconductors used for AC conducting incur hysteresis and eddy current losses in that require increased cooling capacity at a system level and limit the AC frequency.
- NASA has made significant progress developing and characterizing new, higher frequency (>200Hz), AC superconductors that could be used in electrical machines
- Through a series of NASA SBIR contracts, fabrication techniques for MgB₂-based conductors were improved, and small filament sizes as low as 10 μm were demonstrated.
- NASA has also sponsored the development of an experimental capability to calorimetrically measure ac losses and stability properties of superconductors at temperatures as low as 15 K under simultaneous ac transport current and rotating and pulsating magnetic fields as would occur in rotating machine stators

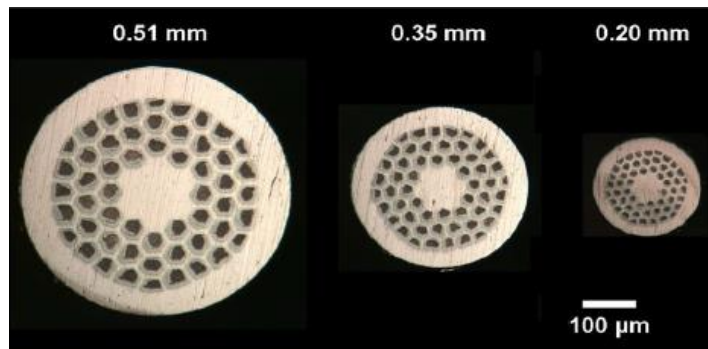

Hyper Tech produced multifilament MgB₂ superconducting wires

Advanced Air Vehicles Program
Advanced Transport Technologies Project

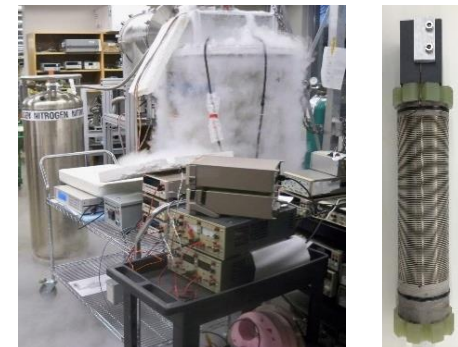

CAPS idealized magnetic field test capability for wire segments

NASA Electric Aircraft Testbed (NEAT)



- NEAT is being developed to enable end-to-end development and testing of a full-scale electric aircraft powertrain
- NEAT is being designed with a reconfigurable architecture that industry, academia, and Government can utilize to further mature electric aircraft technologies.



Capability

- Power up to 24 MW when regenerated
- Thermal up to 2 MW heat rejection
- Altitude (up to 120,000 feet pressure)

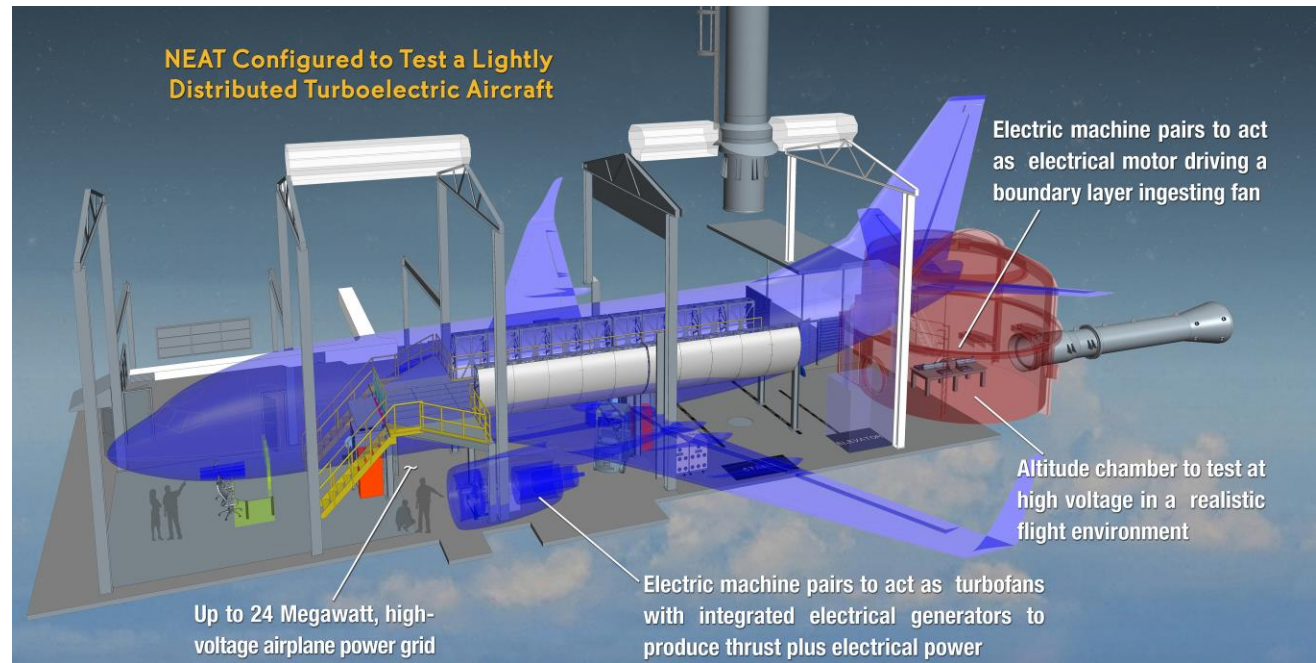

Hybrid Electric Integrated Systems Testbed (HEIST)



- The HEIST is being developed to study power management and transition complexities, modular architectures, and flight control laws for turboelectric distributed propulsion technologies using representative hardware and piloted simulations
- The HEIST is configured in the fashion of an iron bird to provide realistic interactions, latencies, dynamic responses, fault conditions, and other interdependencies for turboelectric distributed aircraft, but scaled to the 200 kW level.
- In contrast with NEAT, HEIST has power and voltage levels that would be considered subscale for a commercial transport, but test capability extends to the entire airplane system and can exercise all aspects of flight control, including cockpit operations.

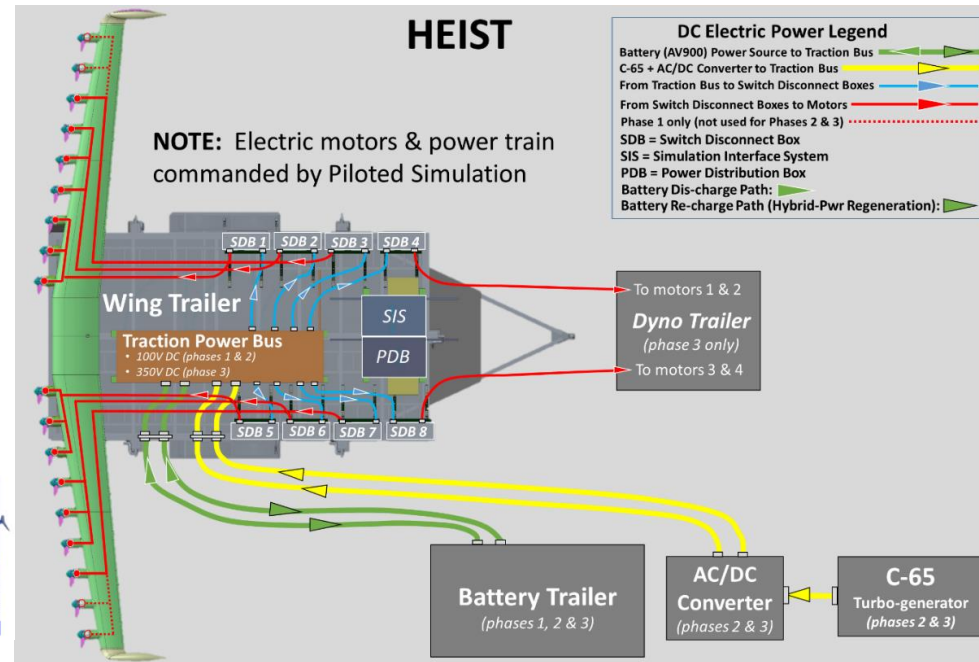
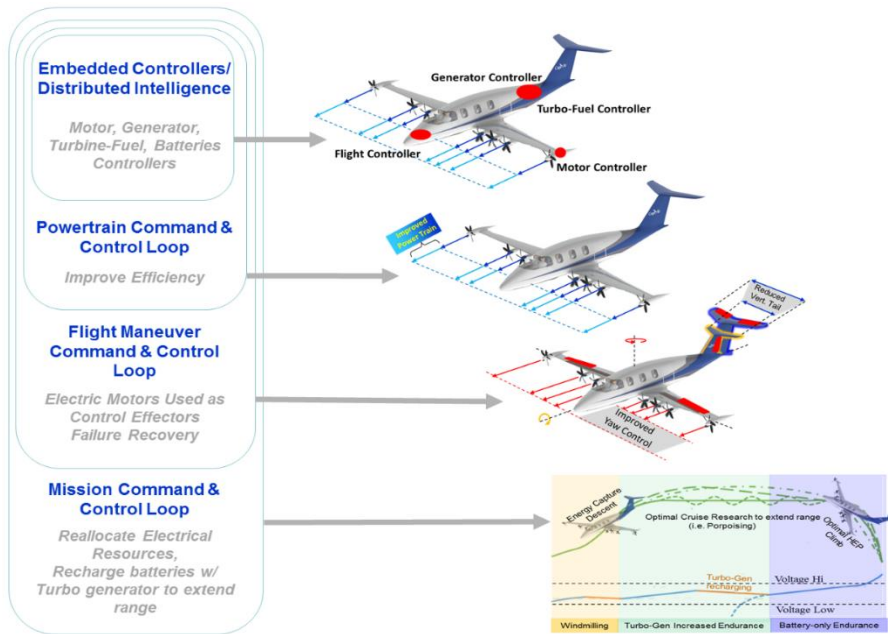

Key areas for Future work



- **Integrated full scale power train**
 - **Objective: End to end MW scale flight weight / efficiency power train**
- **Validation of Boundary-Layer Ingestion Benefits**
 - **Objective: Combination of CFD and testing to validate aero benefits of STARC-ABL or other concept**
- **Turbofan/Generator Integration and Controls**
 - **Objective: Determine optimal turbine/power extraction approach and estimate performance gains or losses.**

Conclusion



- NASA is making significant progress towards establishing the viability of Electrified Aircraft Propulsion (EAP) through a combination of aircraft conceptual design studies and advancement of key tail-pole technologies.
- Partially turboelectric and parallel hybrid candidates have been shown viable for introduction into service in 2035, and a long-term vision has been established for a fully turboelectric system
- NASA is developing key powertrain technologies that are applicable for a wide variety of large aircraft configurations, including electrical machines (motors/generators), converters (inverters/rectifiers), and the underlying electrical materials for EMI filters and cabling.
- In the next 5 years the goal is to narrow the focus to the most viable concepts as a means to prepare for flight demonstrations of those concepts.
- It is believed that the right building blocks are in place to have a viable large-plane EAP configuration tested by 2025 leading to entry into service in 2035 if resources can be harnessed toward pursuing that goal.