

A Novel Reflector/Reflectarray Antenna

An Enabling Technology for NASA's Dual-Frequency ACE Radar

Paul E. Racette, Gerald Heymsfield, Lihua Li
NASA Goddard Space Flight Center (GSFC)
Greenbelt, MD USA

Michael E. Cooley, Richard Park, Peter Stenger
Northrop Grumman Electronic Systems (NGES)
Baltimore, MD USA

Abstract—This paper describes a novel dual-frequency shared aperture Ka/W-band antenna design that enables wide-swath imaging via electronic scanning at Ka-band and is specifically applicable to NASA's Aerosol, Cloud and Ecosystems (ACE) mission. The innovative antenna design minimizes size and weight via use of a shared aperture and builds upon NASA's investments in large-aperture reflectors and high technology-readiness-level (TRL) W-band radar architectures.

The antenna is comprised of a primary cylindrical reflector/reflectarray surface illuminated by a fixed W-band feed and a Ka-band Active Electronically Scanned Array (AESA) line feed. The reflectarray surface provides beam focusing at W-band, but is transparent at Ka-band.

I. INTRODUCTION

NASA's Earth Science Decadal Survey calls for an Aerosol, Cloud and Ecosystems (ACE) mission to provide measurements enabling a better understanding of the role of aerosols on cloud development. The ACE Science Working Group recommends a dual-frequency radar comprised of a fixed-beam 94 GHz (W-band) radar and a wide-swath 35 GHz (Ka-band) imaging radar. Our ACE antenna architecture provides a shared aperture for dual-frequency radar operation with wide-swath (>100 km) imaging at Ka-band. The antenna system incorporates 2 key technologies; a) a novel dual-band reflector/reflectarray and b) a Ka-band AESA feed module. The benefits of this shared-aperture approach are 100 Km Ka swath imaging and significant reductions in ACE satellite payload size, weight, and cost.

The dual-frequency antenna is comprised of a primary cylindrical reflector/reflectarray surface illuminated by a fixed W-band feed (compatible with a quasi-optical beam waveguide feed, such as that employed on CloudSat) and a Ka-band AESA line feed. The innovative reflectarray surface provides beam focusing at W-band, but it is transparent at Ka-band. The AESA feed design leverages state-of-the-art GaN transmit/receive (T/R) MMICs with high RF output power, high power added efficiency and low noise figure.

II. ACE EARTH SCIENCE MEASUREMENTS

A fundamental goal for the National Academy of Sciences Decadal Survey (DS) Aerosol-Cloud-Ecosystems Mission (ACE) is to advance our ability to observe and predict changes to the Earth's hydrological cycle and energy balance in response to climate forcing, especially those changes associated with the effects of aerosol on clouds and precipitation. ACE is focused on obtaining measurements to reduce the uncertainties in current climate models arising from the lack of understanding of aerosol-cloud interactions.

A. ACE Payload and Mission

The ACE mission instrument suite will continue and enhance many key measurements from preceding satellites, e.g., CloudSat, EarthCARE. To this end, the DS has recommended a dual-frequency (W/Ka-band; 94/35 GHz) Doppler radar to measure cloud profiles and microphysical parameters. The ACE Science Working Group (SWG) developed preliminary science traceability matrices (STM) and white papers for the cloud, aerosol, and ecosystem components. The ACE Cloud and Radar Working Groups (CWG and RWG) have a number of recommendations on instrument requirements for the mission including a cross-track scanning capability for the Ka-band radar for capturing the 3-D context of the observed cloud-scenes. Scanning capability increases the statistical representativeness of clouds, it provides a means to calibrate and tune the wider swath passive instruments since the radar provides high vertical resolution profiles, and it will lead to improved combined (multi-instrument) retrieval algorithms.

In October 2009, the SWG established a 50 km swath requirement at Ka and a 100 km goal due to the significant advantages provided by a wide swath imaging radar. The antenna design described herein provides a direct path to the 100 km swath at Ka, while reducing cost, weight, and size.

B. Prior Missions and Earth Science Considerations

ACE radar predecessors operated at 94 GHz (CloudSat, EarthCARE) or at 13 and 35 GHz (GPM Dual-frequency Precipitation Radar). ACE's dual-frequency approach will significantly improve determination of particle size in the vertical column. The utility of Ka and W-band radars has

Table 2. Reflector/reflectorarray antenna design provides SWaP, cost and performance advantages for ACE

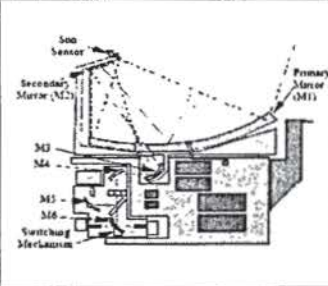
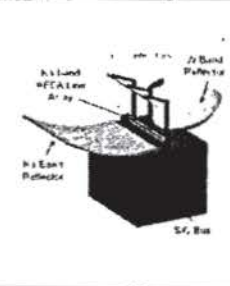
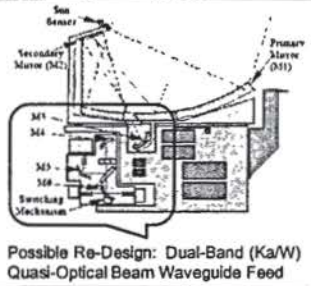
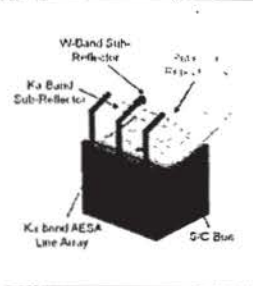
Antenna Design Approach	CloudSat Single Reflector, W-Band	Two Reflectors One at W-Band One at Ka-Band	"Dual-Band Reflector" Add Ka-Band to Quasi-Optic Feed	NGES/GSFC Reflector/ Reflectorarray
				
Dual-Band Capability	None	Good	Good	Good
Ka-Band Wide FOV	None	Good	Poor	Good
Size and Weight	Good	Poor	Good	Good
TRL	9	3-4	3-4	3-4

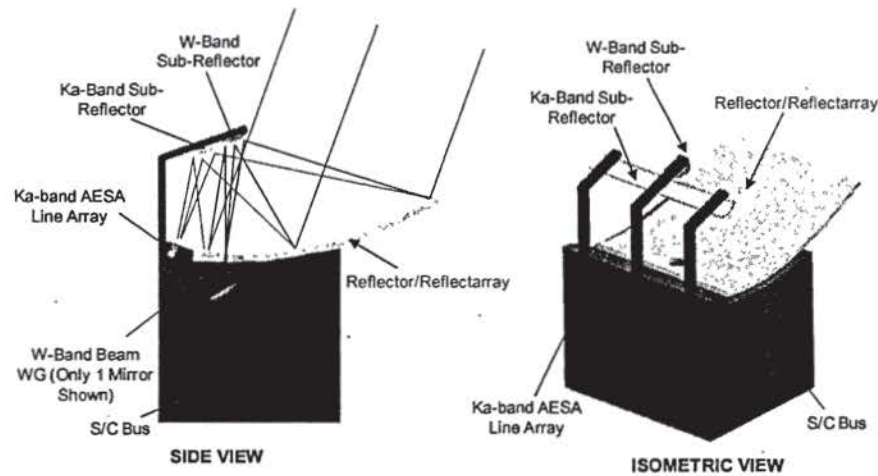

Fig. 2. Dual-band ACE radar antenna architecture leverages CloudSat Radar hardware heritage, and enables incorporation of an electronically scanned Ka-band radar using a shared (Ka/W) aperture

A. Comparative Assessment of Antenna Design Approaches

Augmenting the legacy CloudSat W-band capability with a wide azimuth FOV Ka-band radar will provide improved radar capabilities for the ACE mission. This can be accomplished by employing a unique reflector/reflectorarray design that offers key performance advantages. Table 2 compares several different antenna design approaches. It illustrates the advantages of the reflector/reflectorarray design in terms of performance and SWAP. The CloudSat antenna design is included as a point of reference.

B. NGES/GSFC Dual-Band Antenna Design Summary

The dual-band reflector/reflectorarray antenna system design is shown in Figure 2. For Ka-band operation, the cylindrical reflector is fed by an AESA located at the virtual focal line of the cylinder (Cassegrain folded optics) and azimuth electronic scanning is provided by the feed. For W-band operation, a horn feed source is located at a virtual

focal point (Cassegrain optics) as shown. A very thin printed circuit reflectarray surface (transparent at Ka-band) provides azimuthal focusing of the W-band energy to/from the main parabolic cylinder reflector. The W-band reflectarray surface also provides a slight displacement of the feed/focus in elevation thereby enabling separation from the Ka-band feed. This approach retains co-alignment of the beams.

Printed circuit reflectarray developments date back over 20 years and the technology is now well-established [2-7]. GSFC pioneered the application of W-band reflectarray radar antennas with the Cloud Radar System (CRS) flight and ground-based antennas. Both antennas have excellent performance [2]. See Figure 4. Each uses displaced feeds for co- and cross-polarizations and a reflectarray surface that corrects for astigmatic aberrations.

C. Ka-Band AESA Feed

The incorporation of an AESA line feed at Ka-band enables electronic scanning (wide FOV) for radar imaging. However, it also provides other significant advantages as

outlined in Table 3. One notable advantage is the low azimuth sidelobe level enabled by the AESA amplitude taper control and calibration. The 2 meter AESA line feed is comprised of T/R modules using GaN, GaAs and Si MMICs. The design integrates RF, DC, and thermal management concepts into a single fully hermetic, low loss, LTCC (low temperature co-fired ceramic) package.

Table 3. Ka-Band AESA Feed Provides Numerous Advantages for ACE

Advantage/Benefit	Description
Wide Az FOV Enables Imaging	• AESA feed provides Az electronic scanning
Enhanced Reliability	• Distributed nature of AESA feed provides graceful degradation • Robust design meets effective isotropic radiated power (EIRP) spec with 10% T/R module failure rate
Ultra-Low Az Sidelobes, Image Fidelity	• AESA feed has amp/phase control • High tolerance reflector surface accuracy • Highly accurate reflectarray surface phasing
Sensor Flexibility, Beamwidth Control	• Beam can be broadened in Az via phase spoiling • Provides FOV/coverage flexibility if needed
Calibration/Correction	• AESA feed has amp/phase control • Enables calibration/correction for thermal distortion and/or alignment errors
Growth Path – Multiple Az (Rx) Beams	• AESA technology enables multiple Az beams • Supports sensor capability spiral growth path for ACE follow-on missions

The baseline design for the AESA T/R module is shown in Figure 3. This design leverages NGES's experience with existing silicon ASIC, GaAs and GaN MMIC designs, optimizing technology choices based on DC and thermal efficiency, suitability for space, and RF performance. Several key T/R module design and technology trades will be conducted. Trades will address 1) duplexing, 2) LNA technology, 3) amplitude tapering (transmit), 4) low temperature co-fired ceramic (LTCC) packaging, and 5) thermal design. The front end GaN MMICs include the power amplifier (PA), low-noise amplifier (LNA), and duplexer functions for each channel. Design trades will dictate final chip partitioning and the number of outputs per channel.

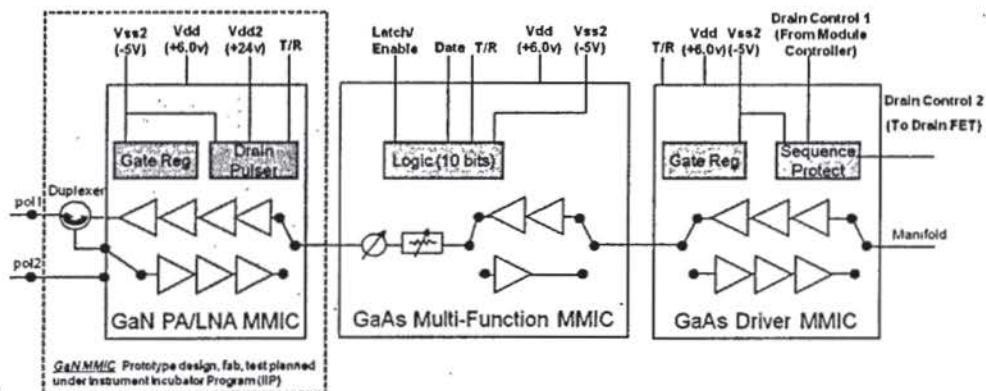

Fig. 3. Ka-band T/R module has switchable polarization on Rx and efficient GaN PA/LNA MMICs.

D. Reflector/Reflectarray

Printed Circuit Reflectarray Technology - The State of the Art: The development of printed circuit reflectarray technology that began over 20 years ago provides a mature technology basis for our design. Early reflectarray work is described in the following references [2, 3-7]. More recently, there has been significant activity in areas particularly relevant to this design effort; 1) millimeter wave reflectarrays [2, 8-11], 2) dual-frequency reflectarrays [12], and 3) space-based reflectarrays [12-15]. Our ACE antenna design leverages these past developments. However, our reflector/reflectarray design exploits the technology in a new way enabling a dual-band architecture with a Ka-band scanning line feed and a fixed beam W-band point source.

As shown in Figure 4, the GSFC CRS radar employs W-band printed circuit reflectarray technology successfully demonstrated by CRS flights and ground-based measurements conducted over the past decade.

Reflector/Reflectarray Architecture: Our dual-band, shared aperture antenna design (Figure 2) combines AESA, reflector and reflectarray technologies in a unique manner that provides distinct advantages. The aperture design enables azimuth electronic scanning at Ka-band via use of an AESA line source feeding the parabolic cylinder reflector. This same reflector surface is shared for W-band operation, however a very thin single layer W-band printed circuit reflectarray surface (transparent at Ka-band) is also applied to the surface of the reflector. The solid parabolic cylinder reflector itself provides no azimuth focusing, however the reflectarray surface focuses the W-band beam. While the dominant W-band reflectarray focusing effect is in azimuth, the reflectarray surface also applies a very modest elevation phase gradient, allowing a slight displacement of the focus. The W-band reflectarray surface design also supports dual polarization operation. Since the resultant "virtual" W-band focal point does not lie on the Ka-band focal line, there is no real estate conflict/contention between the Ka-band AESA (line feed source) and the W-band quasi-optical feed.

We have developed an antenna loss budget, shown in Table 4, that address both Ka and W-band performance.

Reflector/Reflectarray Design, Synthesis, Analysis: The

synthesis and analysis of the reflector/reflectarray is done via use of geometrical optics (GO) and physical optics (PO) based design tools. The W-band reflectarray design utilizes a MATLAB code that employs a PO design methodology. Several working reflectarrays have been developed based upon this code/methodology.

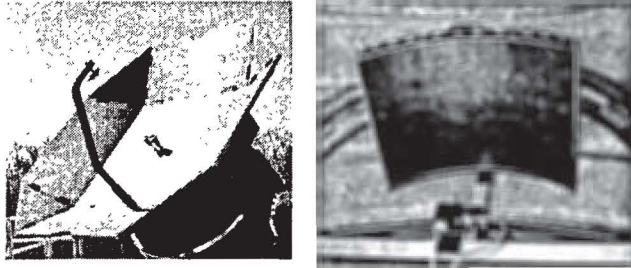

Fig. 4. W-Band reflectarrays designed and developed for GSFC CRS radar.

The reflectarray design methodology and underlying MATLAB analysis code is similar to PO/GO design tools such as those employed by the TICRA GRASP and OSU SATCOM codes [16,17]. However, the reflectarray surface is gridded into unit cells consistent with the printed circuit reflectarray element grid (nominally $\sim 0.6 \lambda$ spacing) and the reflection phase from each cell is left as a variable (not 180° as for standard PO/GO). The MATLAB code generates a far-field vector sum of the fields from each of the reflectarray elements (or unit cells) to enable calculation of an antenna pattern. And, this is done via a synthesis methodology; each individual reflectarray surface element phase is adjusted to coherently focus and form a beam in a prescribed direction. These fixed reflectarray element phases are physically realized by an array of printed circuit elements of various sizes on a Kapton substrate that is bonded to the reflector.

The Ka-band reflector analysis is performed using the TICRA GRASP code. This code is the industry standard for reflector design analysis.

Reflectarray Element Design and Analysis: The detailed analysis and design of the reflectarray surface element is a critical part of the overall design. Printed circuit

Table 4. Mini-spec and gain loss budget for dual-band ACE antenna design

Parameter	Ka Gain (dB)	W Gain (dB)	Comments
Maximum directivity (dBi)	64.1	72.7	3m x 5 m aperture
Spillover efficiency (dB)	-0.3	-0.3	Estimate
Taper Efficiency (dB)	-1.2	-2.0	Estimate
Dielectric and Conductor Loss (dB)	-0.1	-0.7	W-band includes element losses
Phase error losses (dB)	-0.3	-0.7	Estimate
Feed losses (dB)	-0.5	-0.5	VSWR and line losses
Realized Gain (dBi)	61.7	68.5	

reflectarrays have been built using various element types including dipoles, microstrip patches and rings. In our preliminary analysis, we have shown that a ring element yields satisfactory performance by providing dual-pol phase control at W-band and transparency at Ka-band. Further trades and analysis are focusing on optimizing the element for bandwidth, total phase excursion, low loss, and tolerance/sensitivity.

Our baseline element design and associated RF performance is shown in Figure 5. In developing this ring design, we considered and balanced the overall achievable phase shift and element Q. This type of design trade is typical for reflectarrays; loss, Q and tolerance/sensitivity (embodied in the slope of element S-curve in Figure 5) must be balanced with achievable phase shift range. We also considered the frequency selectivity of this element design, i.e. its ability to pass Ka-band energy without undue distortion of the reflection phase. The average phase distortion at Ka-band is very small, and this effect is captured in the gain performance summary in Table 4.

Mechanical Design, Materials and Tolerance Considerations: We have also addressed the mechanical design of the reflector/reflectarray system. Our reflector/reflectarray design will incorporate composite reflectors with a thin printed circuit reflectarray layer using space-qualified materials and mature fabrication methods.

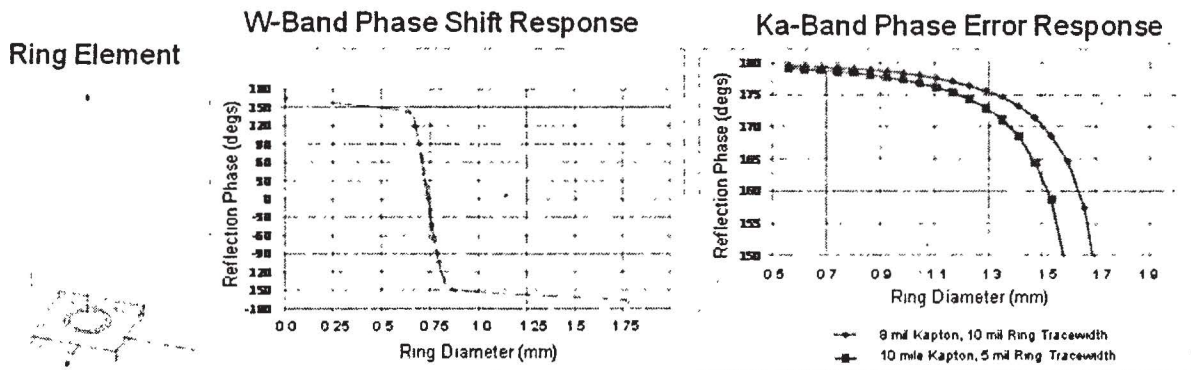

Fig. 5. Reflectarray ring element design and associated predicted RF performance (HFSS™ software).

The reflectarray layer uses a flexible 10 mil (.25 mm) Kapton substrate; Kapton has extensive space heritage for RF/antenna applications (e.g., dual-gridded reflectors for C/Ku band communication satellites) [18] and it also used for space blankets. We have considered material, printed circuit etching/registration, and reflector surface tolerances in our initial design. While tolerances are a challenge, analyses indicate that our reflector/reflectarray design is consistent with realizable hardware tolerances.

IV. SUMMARY

The design of a novel dual-frequency (Ka/W-band) shared aperture antenna system for NASA's Aerosol, Cloud and Ecosystems (ACE) mission has been described. This antenna design enables wide-swath imaging via electronic scanning at Ka-band and minimizes size and weight via use of a shared aperture. The antenna is comprised of a primary cylindrical reflector/reflectarray surface illuminated by a fixed W-band feed and a Ka-band AESA line feed.

A detailed antenna design effort, funded under a NASA ESTO Instrument Incubator Program (IIP), is presently underway. This IIP effort has several key thrusts including: 1) development of a more detailed full-scale antenna design suitable for the ACE dual-band radar mission, 2) risk reduction hardware demos (a scale model reflector/reflectarray demo and T/R module MMICs), 3) airborne flight demonstration of a reflector/reflectarray scale model antenna.

ACKNOWLEDGMENT

The authors would like to thank NASA's Earth Science and Technology Office (ESTO) for their support of the ACE Mission and the IIP initiative which is enabling the development of these antenna technologies. We also thank the ACE Science Working Group (SWG) for their advocacy and support of the mission and generation of driving radar and antenna requirements.

The authors would also like to acknowledge and thank Goddard Space Flight Center (GSFC) and Northrop-Grumman Electronic Systems (NGES) for providing internal funding for early ACE radar and antenna design efforts that laid the groundwork for the developments described herein.

REFERENCES

- [1] Ackerman, S., A. Fridland, E. Jensen, J. Mace, R. Marchand, S. Platnick, D. Starr, G. Stephens, October 2009: ACE clouds, aerosol, and precipitation whitepaper (Draft as of 4 October 2009).
- [2] L. Li, G. M. Heymsfield, P. Racette, L. Tian, E. Zenker, "A 94-GHz Cloud Radar System on a NASA High-Altitude ER-2 Aircraft," *J. of Atmospheric and Oceanic Tech.*, 21 (9): 1378-1388, September 2004.
- [3] J. Huang, J. Encinar, *Reflectarray Antennas*, John Wiley and Sons, Inc., 2008.
- [4] J. Shaker, M. R. Chaharmir, M. Cuhaci, A. Ittipiboon, "Reflectarray Research at the Communications Research Centre Canada," *IEEE Antennas and Propagation Magazine*, pp. 31-52, Vol. 50, No. 4, Aug. 2008.
- [5] J. Huang, "Capabilities of Printed Reflectarray Antennas," *IEEE Symposium on Phased Array Systems and Technology*, pp. 131-134, 1996.
- [6] J. Huang, "Microstrip Reflectarray," *IEEE AP-S/URSI Symposium*, London, Canada, pp. 612-615, June 1991.
- [7] A. Kelkar, "FLAPS: Conformal Phased Reflecting Surfaces," *Proceedings of the National Radar Conference*, pp. 58-62, 1991.
- [8] D. M. Pozar, S. D. Targonski, H. D. Syrigos, "Design of Millimeter Wave Microstrip Reflectarrays," *IEEE Transactions Antennas and Propagation*, pp. 1008-1011, Vol. 45, No. 2, Feb. 1997.
- [9] W. Menzel, D. Pilz, M. Al-Tikriti, "Millimeter-Wave Folded Reflector Antennas with High Gain, Low Loss and Low Profile," *IEEE Antenna and Propagation Magazine*, pp. 24-29, Vol. 44, No. 3, June 2002.
- [10] I. Y. Tarn, Y. S. Wang, S. J. Chung, "A Dual Mode Millimeter-Wave Folded Microstrip Reflectarray Antenna," *IEEE Transactions Antennas and Propagation*, pp. 1510-1517, Vol. 56, No. 6, June 2008.
- [11] J. Lanteri, A. Zeitler, J.-Y. Dauvignac, Ch. Pichot, C. Migliaccio, P. Feil, W. Menzel, "Investigation of Wideband Millimetre-Wave Reflectarrays for Radar Applications in W Band," pp. 826-830, *EuCAP 2009*.
- [12] S. Hsu, C. Han, J. Huang, K. Chang, "An Offset Linear Array Fed Ku/Ka Dual-Band Reflectarray for Planet Cloud/Precipitation Radar," *IEEE Transactions Antennas and Propagation*, pp. 3114-3122, Vol. 55, No. 11, Nov. 2007.
- [13] J. A. Encinar, M. Arrebola, G. Toso, "A Parabolic Reflectarray for Bandwidth Improved Contoured Beam Coverage," pp. 1-5, *EuCAP 2007*.
- [14] R. Hodges, M. Zawadzki, "Design of a Large Dual Polarized Ku-Band Reflectarray for Spaceborne Radar Altimeter," *IEEE AP-S Symposium*, Monterey, CA, pp. 4356-4359, June 2005.
- [15] R. Romanofsky, C. Mueller, C. V. Chandrasekar, "Concept for Low Cost, High Efficiency Precipitation Radar System Based On Ferroelectric Reflectarray Antenna," *IEEE Radar Conference*, pp. 1-6, 2009.
- [16] M. E. Cooley, D. Davis, "Reflector Antennas", Chapter 12 of *Radar Handbook*, pp. 12.16-12.35, M. Skolnik Ed., 3rd Edition, McGraw-Hill, 2008.
- [17] G. F. Paynter, T. H. Lee, W. D. Burnside, "Expansion of Existing EM Workbench for Multiple Computational Electromagnetics Codes," *IEEE Antennas and Propagation Magazine*, Vol. 45, No. 3, June 2003.
- [18] P. Ramanujam, P. H. Law, D. A. White, "An Adaptable Dual Gridded Reflector Geometry for Optimum Cross Polar Performance," *IEEE Antennas and Propagation Symposium*, 2003.