



# Overview of the Development and Mission Application of the Advanced Electric Propulsion System (AEPS)

*Daniel A. Herman, Todd A. Tofil, Walter Santiago, and Hani Kamhawi  
Glenn Research Center, Cleveland, Ohio*

*James E. Polk, John S. Snyder, Richard R. Hofer, and Frank Q. Picha  
Jet Propulsion Laboratory, Pasadena, California*

*Jerry Jackson and May Allen  
Aerojet Rocketdyne, Canoga Park, California*

## NASA STI Program . . . in Profile

Since its founding, NASA has been dedicated to the advancement of aeronautics and space science. The NASA Scientific and Technical Information (STI) Program plays a key part in helping NASA maintain this important role.

The NASA STI Program operates under the auspices of the Agency Chief Information Officer. It collects, organizes, provides for archiving, and disseminates NASA's STI. The NASA STI Program provides access to the NASA Technical Report Server—Registered (NTRS Reg) and NASA Technical Report Server—Public (NTRS) thus providing one of the largest collections of aeronautical and space science STI in the world. Results are published in both non-NASA channels and by NASA in the NASA STI Report Series, which includes the following report types:

- **TECHNICAL PUBLICATION.** Reports of completed research or a major significant phase of research that present the results of NASA programs and include extensive data or theoretical analysis. Includes compilations of significant scientific and technical data and information deemed to be of continuing reference value. NASA counter-part of peer-reviewed formal professional papers, but has less stringent limitations on manuscript length and extent of graphic presentations.
- **TECHNICAL MEMORANDUM.** Scientific and technical findings that are preliminary or of specialized interest, e.g., “quick-release” reports, working papers, and bibliographies that contain minimal annotation. Does not contain extensive analysis.
- **CONTRACTOR REPORT.** Scientific and technical findings by NASA-sponsored contractors and grantees.
- **CONFERENCE PUBLICATION.** Collected papers from scientific and technical conferences, symposia, seminars, or other meetings sponsored or co-sponsored by NASA.
- **SPECIAL PUBLICATION.** Scientific, technical, or historical information from NASA programs, projects, and missions, often concerned with subjects having substantial public interest.
- **TECHNICAL TRANSLATION.** English-language translations of foreign scientific and technical material pertinent to NASA's mission.

For more information about the NASA STI program, see the following:

- Access the NASA STI program home page at <http://www.sti.nasa.gov>
- E-mail your question to [help@sti.nasa.gov](mailto:help@sti.nasa.gov)
- Fax your question to the NASA STI Information Desk at 757-864-6500
- Telephone the NASA STI Information Desk at 757-864-9658
- Write to:  
NASA STI Program  
Mail Stop 148  
NASA Langley Research Center  
Hampton, VA 23681-2199



# Overview of the Development and Mission Application of the Advanced Electric Propulsion System (AEPS)

*Daniel A. Herman, Todd A. Tofil, Walter Santiago, and Hani Kamhawi  
Glenn Research Center, Cleveland, Ohio*

*James E. Polk, John S. Snyder, Richard R. Hofer, and Frank Q. Picha  
Jet Propulsion Laboratory, Pasadena, California*

*Jerry Jackson and May Allen  
Aerojet Rocketdyne, Canoga Park, California*

Prepared for the  
35th International Electric Propulsion Conference  
sponsored by IEPC  
Atlanta, Georgia, October 8–12, 2017

National Aeronautics and  
Space Administration

Glenn Research Center  
Cleveland, Ohio 44135

## Acknowledgments

The authors would like to like to thank the Space Technology Mission Directorate through the Solar Electric Propulsion Technology Demonstration Mission Project for funding the joint NASA Glenn Research Center and Jet Propulsion Laboratory development of the Advanced Electric Propulsion System. The authors would also like to thank the many NASA/Aerojet Rocketdyne review board members and subject matter experts for providing their expertise and technical guidance to the development of Advanced Electric Propulsion System and its broader Ion Propulsion Subsystem mission application.

*Level of Review:* This material has been technically reviewed by technical management.

Available from

NASA STI Program  
Mail Stop 148  
NASA Langley Research Center  
Hampton, VA 23681-2199

National Technical Information Service  
5285 Port Royal Road  
Springfield, VA 22161  
703-605-6000

This report is available in electronic form at <http://www.sti.nasa.gov/> and <http://ntrs.nasa.gov/>

# Overview of the Development and Mission Application of the Advanced Electric Propulsion System (AEPS)

Daniel A. Herman, Todd A. Tofil, Walter Santiago, and Hani Kamhawi  
National Aeronautics and Space Administration  
Glenn Research Center  
Cleveland, Ohio 44135

James E. Polk, John S. Snyder, Richard R. Hofer, and Frank Q. Picha  
Jet Propulsion Laboratory  
Pasadena, California 91109

Jerry Jackson and May Allen  
Aerojet Rocketdyne  
Canoga Park, California 91304

## Abstract

NASA remains committed to the development and demonstration of a high-power solar electric propulsion capability for the Agency. NASA is continuing to develop the 14 kW Advanced Electric Propulsion System (AEPS), which has recently completed an Early Integrated System Test and System Preliminary Design Review. NASA continues to pursue Solar Electric Propulsion (SEP) Technology Demonstration Mission partners and mature high-power SEP mission concepts. The recent announcement of the development of a Power and Propulsion Element (PPE) as the first element of an evolvable human architecture to Mars has replaced the Asteroid Redirect Robotic Mission (ARRM) as the most probable first application of the AEPS Hall thruster system. This high-power SEP capability, or an extensible derivative of it, has been identified as a critical part of an affordable, beyond-low-Earth-orbit, manned-exploration architecture. This paper presents the status of the combined NASA and Aerojet Rocketdyne AEPS development activities and updated mission concept for implementation of the AEPS hardware as part of the ion propulsion system for a PPE.

## Nomenclature

AEPS	Advanced Electric Propulsion System
AR	Aerojet Rocketdyne
ARRM	Asteroid Redirect Robotic Mission
CDR	Critical Design Review
DRO	Distant Retrograde Orbit
DSG	Deep Space Gateway
DST	Deep Space Transport
EDU	Engineering Development Unit
EIST	Early Integrated System Test
EM	Exploration Mission
EP	Electric Propulsion
FM	Flight Model
FT	Flight Thruster
GRC	Glenn Research Center

HEOMD	Human Exploration and Operations Mission Directorate
HERMeS	Hall Effect Rocket with Magnetic Shielding
HDPU	High Power Distribution Unit
IPS	Ion Propulsion System
JPL	Jet Propulsion Laboratory
LV	Latch Valve
NEXT-C	NASA’s Evolutionary Xenon Thruster – Commercial
NRHO	Near Rectilinear Halo Orbit
PDP	Plasma Diagnostics Package
PDR	Preliminary Design Review
PMA	Propellant Management Assembly
PPE	Power and Propulsion Element
PPU	Power Processing Unit
RFU	Request for Information
SEP	Solar Electric Propulsion
SLS	Space Launch System
STMD	Space Technology Mission Directorate
TDU	Technology Development Unit
VF	Vacuum Facility
XFC	Xenon Flow Controller
XFCM	Xenon Flow Control Module
QM	Qualification Model

## **Introduction**

For missions beyond low Earth orbit, spacecraft size and mass can be dominated by onboard chemical propulsion systems and propellants that may constitute more than 50 percent of spacecraft mass. This impact can be substantially reduced through the utilization of Solar Electric Propulsion (SEP) due to its significantly higher specific impulse. Studies performed for NASA’s Human Exploration and Operations Mission Directorate (HEOMD) and Science Mission Directorate have demonstrated that a 40 kW-class SEP capability can be enabling for both near term and future architectures and science missions (Ref. 1).

Since 2012 NASA has been developing a 14 kW Hall thruster electric propulsion string that can serve as the building block for a 40 kW-class SEP capability. NASA continues to evolve a human exploration approach for beyond low-Earth orbit and to do so, where practical, in a manner involving international, academic, and industry partners (Ref. 2). NASA publicly presented a reference exploration concept at the HEOMD Committee of the NASA Advisory Council meeting on March 28, 2017 (Ref. 3). This approach is based on an evolutionary human exploration architecture, depicted in Figure 1, expanding into the solar system with cis-lunar flight testing and validation of exploration capabilities before crewed missions beyond the earth-moon system and eventual crewed Mars missions. One of the key objectives is to achieve human exploration of Mars and beyond through the prioritization of those technologies and capabilities best suited for such a mission in accordance with the stepping stone approach to exploration (Ref. 4). High-power solar electric propulsion is one of those key technologies that has been prioritized because of its significant exploration benefits. A high-power, 40 kW-class Hall thruster propulsion system provides significant capability and represents, along with flexible blanket solar array technology, a readily scalable technology with a clear path to much higher power systems.

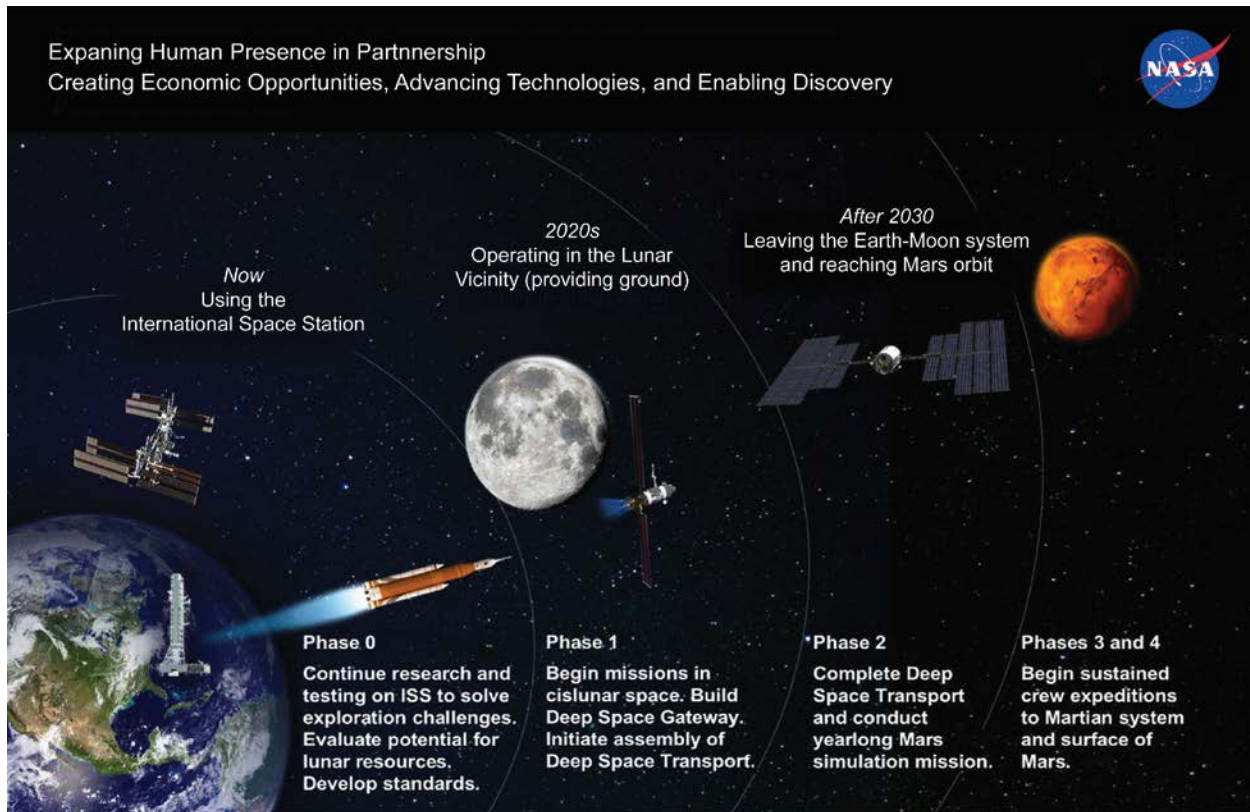

Figure 1.—NASA Human Exploration Vision including Deep Space Gateway (DSG) and Deep Space Transport (DST) (Ref. 5).

The 14 kW Hall thruster system development, led by the NASA Glenn Research Center and the Jet Propulsion Laboratory, began with maturation of the high-power Hall thruster and power processing unit. The technology development work transitioned to Aerojet Rocketdyne via a competitive procurement selection for the Advanced Electric Propulsion System (AEPS) contract. The AEPS contract includes the development, qualification, and multiple flight 14 kW electric propulsion string deliveries. The AEPS Electric Propulsion (EP) string consists of the Hall thruster, power processing unit (including digital control and interface functionality), xenon flow controller, and associated intra-string harnesses. NASA continues to support the AEPS development leveraging in-house expertise, plasma modeling capability, and world-class test facilities. NASA also executes AEPS and mission risk reduction activities to support the AEPS development and mission application. This paper provides an overview of the NASA and Aerojet Rocketdyne development activities and mission application of the AEPS Hall thruster system.

### NASA Exploration and the Power and Propulsion Element Overview

Phase 1 of the reference exploration architecture is a cislunar demonstration of exploration systems that build up a Deep Space Gateway (DSG), conceptually shown in Figure 2. The DSG, when docked with an Orion vehicle could potentially support a crew of four for up to 42 days, providing the ability to support multiple partner objectives in Phase 1 and beyond. The first Phase 1 element would be a 50 kW-class Power and Propulsion Element (PPE). The PPE could be a co-manifested payload on Space Launch Systems (SLS) Exploration Mission-2 (EM-2) in the 2023 timeframe (Ref. 4). One of the HEOMD architecture guidelines is the use of the Space Technology Mission Directorate (STMD) developed 40 kW solar electric propulsion that is being matured and delivered through the AEPS contract (Ref. 5).

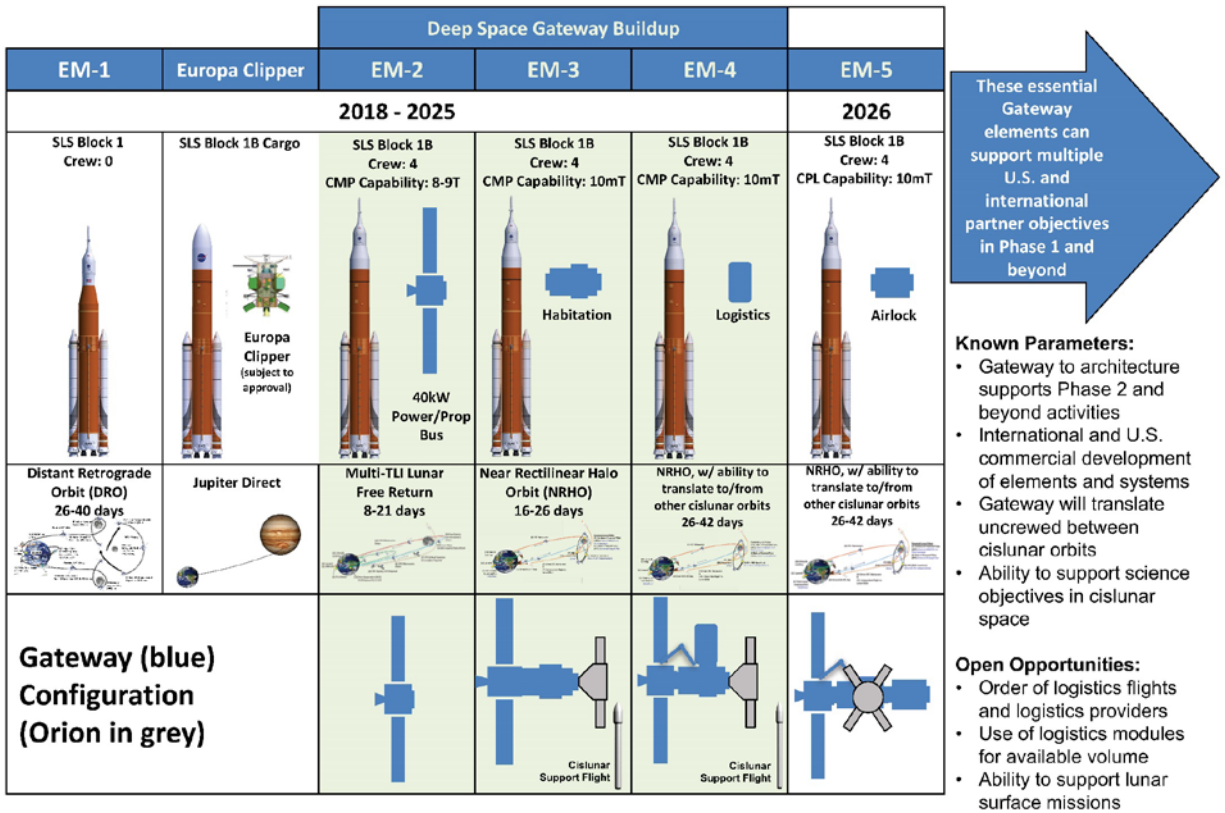

Figure 2.—Human Exploration Vision Phase 1—Deep Space Gateway Conceptual Plan (Ref. 4).

Phase 2 would entail the cislunar validation of exploration systems that will build up a Deep Space Transport (DST) that provides habitation and transportation needs for transporting crew into deep space including supporting human Mars-class missions. The DST could be designed to be reused for three Mars-class missions with minimal resupply and maintenance and could be readied for a shakedown cruise by 2029 (Ref. 4).

### Power and Propulsion Element (PPE)

NASA is investigating an in-house Power and Propulsion Element conceptual design leveraging in-house mission concepts and vehicle designs for the SEP Technology Demonstration Missions and Asteroid Redirect Robotic Mission (ARRM) (Refs. 6 to 9). This PPE concept, illustrated in Figure 3, relies on several key technology areas including high-efficiency, high-power solar arrays and high-power, high-throughput electric propulsion. The intended functions for the PPE are to provide power to DSG elements; provide transportation for the DSG; provide attitude control (passive and active) to the DSG; and to provide communications for Earth, visiting vehicles, and crew on extravehicular activities. The PPE acquisition strategy is still being formulated and options evaluated. On July 17, 2017 there was a dual release of a Request for Information (RFI) to solicit information and ideas for possible use in a cost-effective development of the DSG PPE and a release of a synopsis for PPE studies (Refs. 10 and 11). The PPE study synopsis informs industry that NASA intends to release a solicitation to seek proposals for studies of a Power and Propulsion Element (PPE) targeted for release in the August 2017 timeframe (Ref. 10). The PPE reference capability descriptions that are relevant to the Ion Propulsion System (IPS) are listed in Table 1 (Ref. 11).



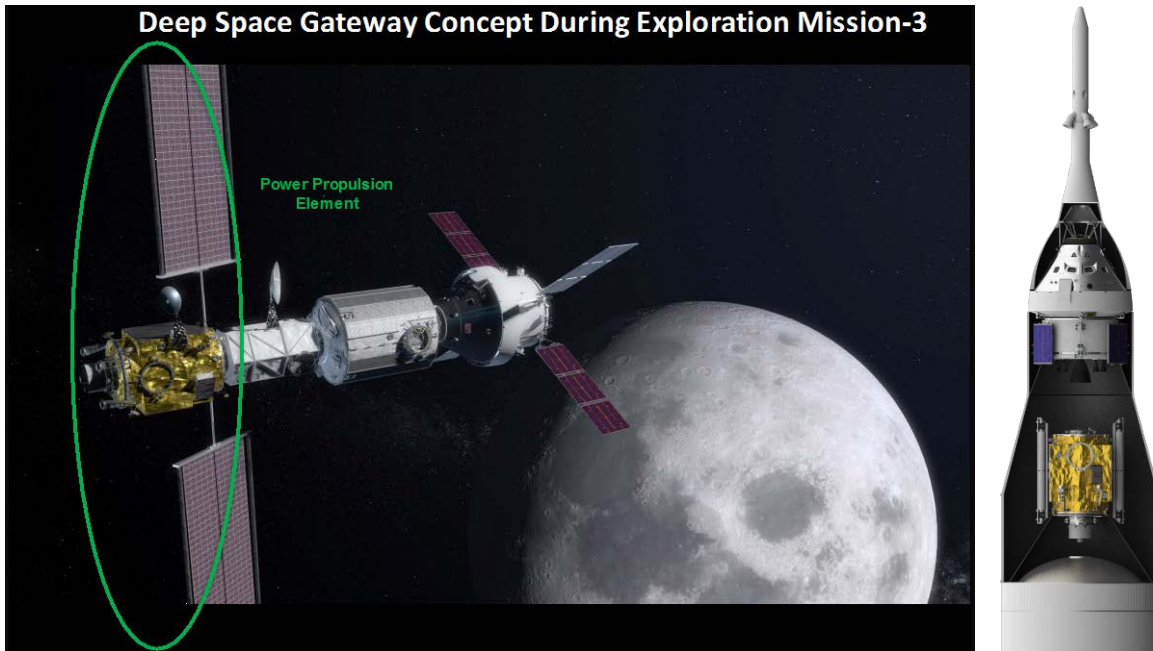

Figure 3.—Conceptual design of the Power and Propulsion Element (PPE) integrated into Deep Space Gateway (left) and stowed co-manifested with Orion on SLS EM-2 (right) (Ref. 4).

TABLE 1.—PPE REFERENCE IPS CAPABILITY DESCRIPTIONS (REF. 11)

Capability title	Reference capability description	Capability supporting comments
1. PPE Lifetime	The PPE will have a minimum operational lifetime of 15 years in cis-lunar space.	The PPE lifetime of 15 years initiates with launch.
2. PPE Power Transfer	The PPE will be capable of transferring up to 24 kW of electrical power to the external hardware.	The 24 kW electrical power value represents the maximum amount of power transferred to the external hardware other than the PPE. The 24 kW power level would be decreased if the external hardware uses Solar Electric Propulsion (SEP) thrusting. Alternatively, this could limit the available power for SEP thrusting.
3A. PPE Propulsion Capability	The PPE will be capable of providing orbit transfers for a stack of TBD mass with a center of gravity of TBD.	The capability of the PPE provides in-space transportation for the external hardware.
3B. PPE Propulsion Capability	The PPE will be capable of providing orbit maintenance for a stack of TBD mass with a center of gravity of TBD.	The capability of the PPE provides in-space transportation for the external hardware.
4. PPE Xenon Capacity	The PPE will have 2,000 kg-class tank Xenon capacity.	The capability of the PPE to provide in-space transportation to the external hardware is expressed in terms of Xenon load (proxy for delta-v) rather than a specific number of orbit transfers.
6. PPE Attitude Control	The PPE will be capable of providing attitude control for external hardware up to (TBD) mass and (TBD) Center of Gravity location.	The PPE will provide attitude control using RCS, momentum wheels, SEP thrust vectoring (TBD) for the entire external hardware. The control authority requirements for attitude control will change over time as additional external hardware is added.
Capability Title	Reference Capability Description	Capability Supporting Comments
10. PPE Refuelability	The PPE will be on-orbit refuelable.	The Power and Propulsion Element will have refueling capability incorporated with/near the forward and aft IDSS compliant interfaces for both xenon and hydrazine.
11. PPE Extensibility	The PPE will demonstrate an advanced integrated solar electric propulsion system including a 50 kW class Solar Electric Propulsion capability that is extensible to future human Mars class missions.	The advanced solar electric propulsion system employs elements that have the solar array power-to-mass ratio, stowed volume efficiency, deployed strength and radiation tolerance, and that have the electric propulsion high-power, specific impulse, and total impulse needed for future Mars missions. This capability also addresses Human Exploration and Operations Exploration Objective P1-06 to demonstrate operation of long-duration high power solar arrays and SEP transportation of in-space propulsion elements.

A flight plasma diagnostics package (PDP) is being considered for inclusion on the PPE to provide the data needed to validate models of high-power SEP operation and spacecraft plasma interactions, design tools that are critical for enabling high-power SEP spacecraft to support future human and robotic missions to Mars. The PDP would provide flight plasma spacecraft interaction data that cannot be accurately assessed by ground test plasma measurements. The PDP would measure the plasma environment, surface erosion, material redeposition, and serve as a tool for thruster characterization. To allow for correlation of the plasma plume transients to thruster transients, an analog discharge current sense is provided from the AEPS power processing unit to the PDP. A potential implementation of the PDP is a government-led development of the PDP that could provide flight hardware to the PPE as government-furnished equipment. An initial concept for the plasma diagnostics package utilizes high heritage instruments flown on prior NASA and other government spacecraft (Ref. 12).

## Ion Propulsion System Description

The conceptual IPS design for the PPE includes four metal-lined, composite-overwrapped pressure vessels capable of storing in excess of 5 tons of xenon propellant. The power processing units are mounted directly to heat-pipe on the same sides of the spacecraft as the solar arrays to minimize direct solar flux. The thrusters are mounted on individual deployable booms that reduce the impact of thruster plume interactions with the solar arrays and one of the docking mechanisms (on the aft end of the spacecraft). The SEP thrusters will provide pitch, yaw, and roll control during ion propulsion thrusting.

The key IPS capabilities, shown in Table 2, are that it will be single fault tolerant while consuming up to 5,000 kg of xenon over an input power range of 6.67 to 40 kW with input voltages ranging from 95 to 140 V. The propellant throughput capability of the IPS is 5,000 kg, which results in 1,700 kg per Hall thruster—by far the largest propellant throughput processed by an electric propulsion system.

The EP string throttling, consistent with AEPS capability, is utilizing constant discharge current (20.8 A) power throttling between 300 to 600 V discharge voltages and constant discharge voltage (300 V) power throttling between 10.4 to 20.8 A discharge currents. The AEPS required performance for the single string throttling described above is illustrated in Table 3. A performance incentive clause on the AEPS contract exists that would result in higher EP string performance than indicated in the table (e.g., 61.5 percent total system efficiency at full power).

TABLE 2.—KEY ION PROPULSION SYSTEM CAPABILITIES

Capability	Value
Total system power	40 kW
Maximum specific impulse	2600 s
Xenon throughput	5,000 kg
Fault tolerance	Redundant string
Solar range	0.8 to 1.7 AU
Input voltage range	95 to 140 V

TABLE 3.—AEPS REQUIRED (MINIMUM)—EP STRING PERFORMANCE

EP string total input power, kW	Discharge voltage, V	Thrust, mN <sup>a</sup>	Mass flow rate, mg/s	System efficiency
13.3	600	589	22.9	0.57
11.1	500	519	22.0	0.55
8.9	400	462	22.1	0.54
6.7	300	386	21.7	0.52
3.4	300	200	11.9	<sup>b</sup> 0.49

<sup>a</sup>Thrust shown here is current best estimate minus experimental uncertainty.

<sup>b</sup>String required to operate at 3.4 kW, but no AEPS performance requirement. Performance shown is notional.

A high-level conceptual block diagram of the IPS is shown in Figure 4. The IPS includes four identical electric propulsion strings, identified in Figure 4, being developed under AEPS. An AEPS electric propulsion string is comprised of the following four elements:

1. Flight Thruster (FT)
2. Power Processor Unit (PPU)
3. Xenon Flow Controller (XFC)
4. Interconnecting Cable Harnesses

The IPS includes four flight AEPS EP strings, but also the high-pressure portion of the xenon feed system that contains the xenon tanks, a propellant management assembly, and the mechanical integration hardware including cabling. Each EP string is operated independently of the others by the spacecraft. Single fault tolerance is achieved through block-redundancy at the EP string level with internal redundancy for the xenon feed system components outside of the EP strings. The PPE conceptual design includes a 2-axis thruster gimbal assembly that is considered part of the Structures and Mechanisms Subsystem.

A major challenge for the development of the electric propulsion system is determining how to appropriately manage the interfaces of the electric propulsion string elements, which need to be defined for the AEPS contract ahead of the maturation of the PPE design. An example of this concern is the

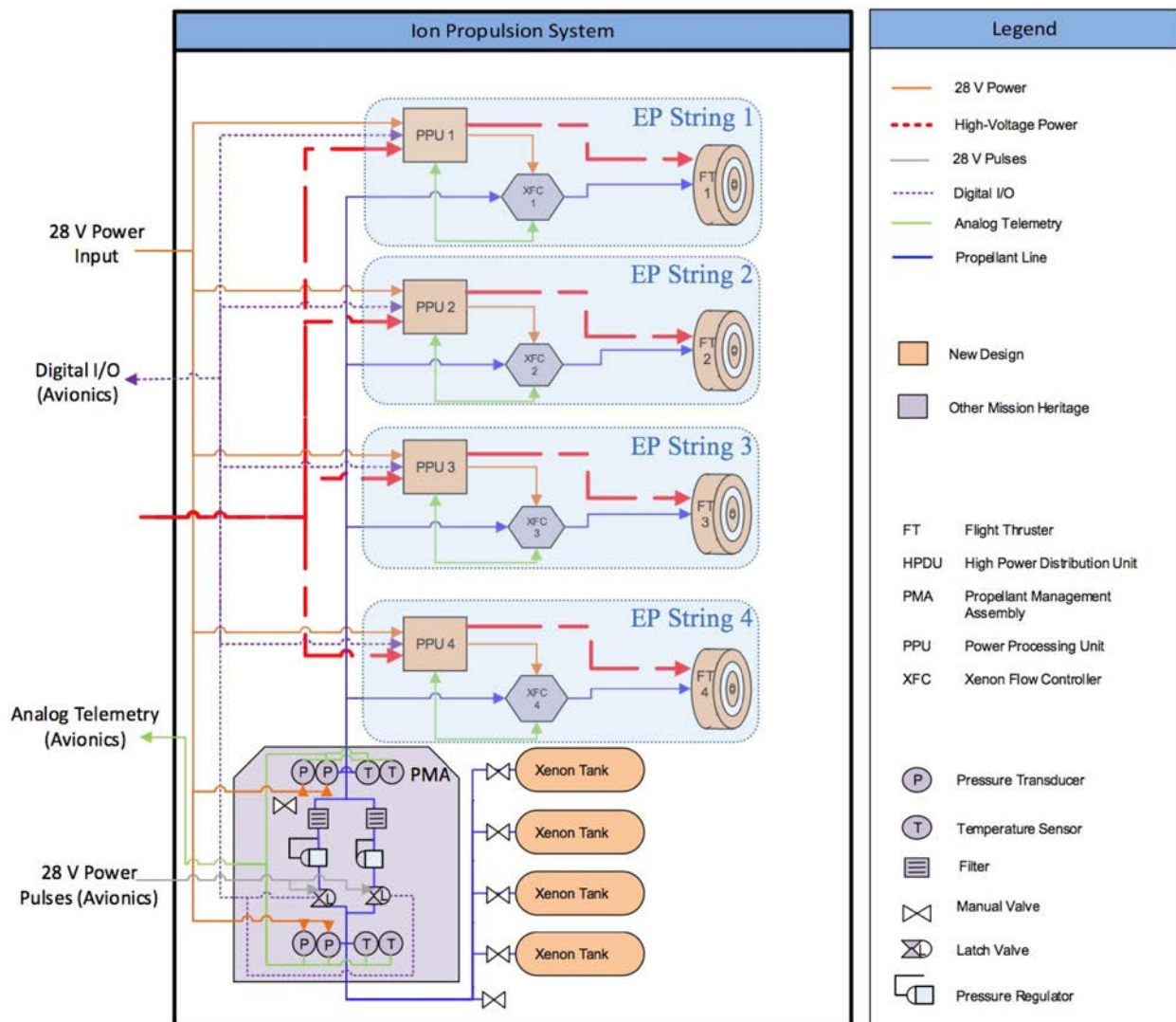

Figure 4.—Top-level PPE Conceptual Ion Propulsion System (IPS) block diagram.

interface between the Hall thruster and the flight gimbal where mechanical integration is nontrivial and where launch load amplification/attenuation through the gimbal to the Hall thruster can alter the loads observed at the thruster (Refs. 13 and 14). The NASA in-house Asteroid Redirect Vehicle design developed for ARRM was used to guide the definition of these AEPS interfaces and appropriate launch loads for AEPS (Ref. 9). These will continually be monitored as the PPE design is matured.

## Advanced Electric Propulsion System Development

In 2010 NASA STMD began developing large, deployable photovoltaic solar array structures for high-power electrical power generation and high-power electric propulsion technologies (Refs. 7, 15 to 19). The maturation of the critical technologies required for the high-power SEP vehicle has made mission concepts utilizing high-power SEP viable (Ref. 20). The high-power electric propulsion investments were in areas having high technical risks and/or long-lead times.

### NASA In-House Development

NASA in-house development of the 12.5 kW Hall Effect Rocket with Magnetic Shielding (HERMeS) thruster, shown in Figure 5, and HP-120 V/800 V power processing unit (PPU) have resulted in three high-fidelity development model thrusters and a brass-board power processing unit that have been extensively tested and characterized separately as well as demonstrated as an integrated system. The HERMeS development plan was formulated from a set of technical risks that could impact mission success (Refs. 21 and 22). Each element of the development plan is traceable to these risks. The comprehensive Technology Development Unit (TDU) test campaign that started in 2015 included: performance, stability, thermal, and wear characterizations; demonstrated thruster performance, verified magnetically shielded operation at high specific impulse, and affirms that the internally mounted cathode minimizes the effects of facility pressure on performance; and demonstrated TDU thruster compliance to qualification-level environments (Refs. 22 and 31). There was no direct development work for the xenon feed controller because it is low-risk and does not require a long development as a result of multiple options available utilizing flight qualified components. The NASA development work validated subsystem design methodologies, developed critical diagnostics, demonstrated performance that meets current mission requirements, made significant strides in life qualification, developed and validated an array of models, and provided the basis for the AEPS requirements. While the focus of the work is now on the AEPS contract and hardware designs, NASA continues to utilize the TDU thrusters for AEPS and mission risk reduction testing as well as for AEPS-specific tests such as the Early Integrated System Test (EIST).

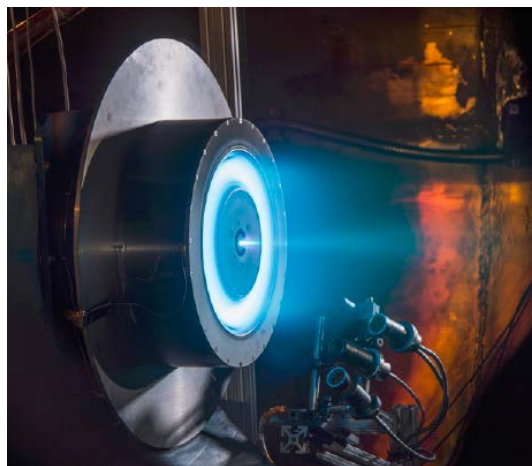

Figure 5.—The 12.5 kW Hall-Effect Rocket with Magnetic Shielding (HERMeS) operating in VF5 at NASA GRC.

## **Advanced Electric Propulsion System Contract**

The AEPS acquisition was initiated for engineering development and subsequent system qualification and flight unit fabrication in order to meet the required flight hardware delivery dates for ARRM. While the ARRM mission has been cancelled, NASA is committed to developing and delivering the AEPS hardware to meet the needs of the PPE and other potential near-term missions. Given the lead times required for the development and fabrication of the electric propulsion strings, the Advanced Electric Propulsion System contract was initiated on May 5, 2015 with the draft RFP release. The competitively-selected cost-plus fixed fee including incentives contract consists of the development of an Engineering Development Unit (EDU) EP string and optional Qualification Model (QM) and Flight Model (FM) hardware delivery within three years (Ref. 32). This contract includes the thrusters, power processing units, xenon flow controllers, and electric harnesses between the subsystems. The contract was awarded to Aerojet Rocketdyne as the prime with major subcontractor ZIN Technologies and VACCO Industries. Management of the contract is being led by the NASA Glenn Research Center. Authorization to proceed for the contract was on May 16, 2016. In addition to the use of the AEPS development and hardware for PPE, the system is being considered for other mission applications (Ref. 33). Additional details regarding the AEPS contract can be found in Reference 34.

### **Advanced Electric Propulsion System (AEPS) Status**

The current state of the contract is that Aerojet Rocketdyne held the system Preliminary Design Review (PDR) in August, 2017 (Ref. 34). The NASA and Aerojet Rocketdyne review board assessed the system and component designs with respect to all system requirements as well as the development risks and schedule. Driving design challenges to the EP string system design are the high-power and high-specific impulse system performance, flow rate control and measurement accuracy, immature vehicle interface definition, and the high thrust accuracy required for deep-space mission operations utilizing EP for primary propulsion and attitude control during EP thrusting.

The driving thruster design challenges are the dynamic operating range including high-power, high-voltage operation, mass, expected spacecraft environmental requirements (dynamic and thermal), and long life (e.g., high propellant throughput) required to provide the necessary mission flexibility to the meet mission needs. Thruster life qualification poses a challenge that is often inherent in an EP system development. Specifically, for the AEPS contract, the challenge is maturing the EDU thruster design well beyond a PDR maturity at system PDR so that the EDU thruster closely represents the QM/FM thruster designs so that extended thruster wear testing could be initiated to generate an appreciable amount of operating duration by the end of the contract to partially validate thruster service life. The likelihood of achieving this difficult challenge was greatly enhanced by the multiple years of development testing of the HERMeS TDU thrusters that were selected as the point of departure for the AEPS EDU thruster design as illustrated in Figure 6.

Aerojet Rocketdyne has built upon the HERMeS thruster development investments with the AEPS thruster design with improved structural capability to survive launch environments, a modified thermal management approach that allows for elimination of the HERMeS thruster radiator, and improvements to manufacturability including incorporation of flight-qualified electromagnet manufacturing process.

The driving PPU design challenges are the dynamic (input and output) operating range including high-power, high-voltage operation, mass, efficiency, the inclusion of the system digital control and interface capability in a high-noise environment, low conducted and radiated emissions to minimize impacts to the vehicle communications while thrusting, and challenges associated with the thermal and mechanical design of a complex, high-voltage, and high-power electronics box that is driving a dynamic thruster load. The AEPS EDU PPU mechanical packaging is shown in Figure 7.



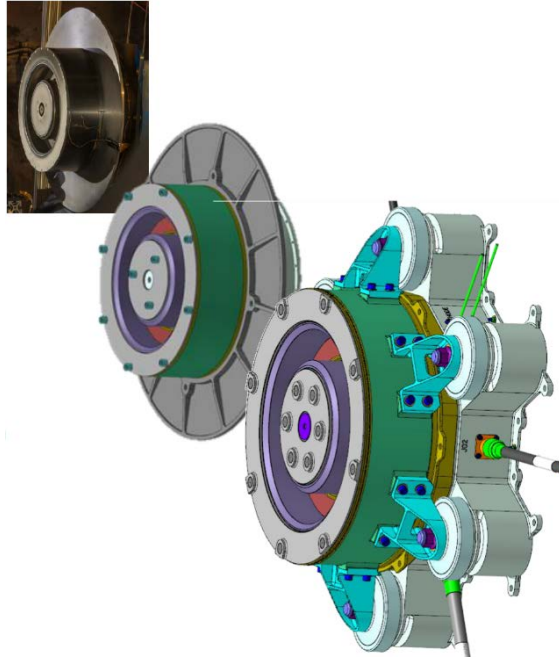

Figure 6.—AEPS EDU thruster design improves upon NASA HERMeS development investments.

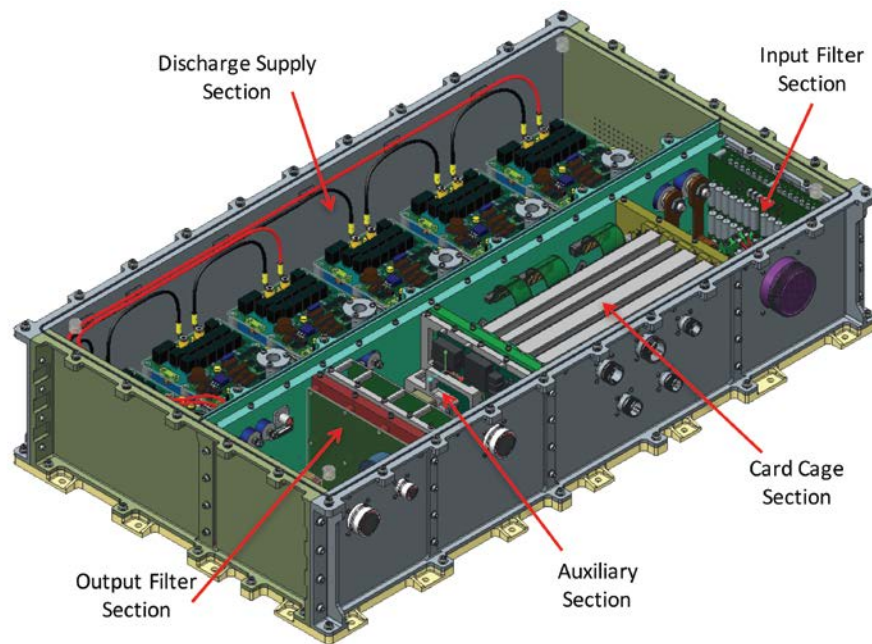

Figure 7.—AEPS EDU PPU design.

The AEPS Xenon Flow Controller (XFC), shown in Figure 8, is a derivative of the Xenon Flow Control Module (XFCM) that was previously developed under a NASA contract by VACCO (Ref. 35). The design maturity of the XFC was the most mature of all of the AEPS components such that the component Critical Design Review (CDR) is planned for one month after system PDR. Driving requirements to the XFC design are the mass flow rate control precision that feeds into system-level thrust precision accuracy, total flow telemetry accuracy that is important to accurately determine xenon propellant usage throughout mission, propellant throughput, and off-nominal operation at up to 3000 psia inlet pressure (in an upstream regulation failure scenario).

### AEPS Early Integrated System Test (EIST)

After completing all test objectives, an AEPS EIST was completed in June 2017 to obtain an early characterization of the system behavior, inform the EDU system/component designs, and reduce risk for the EDU integrated system test (Ref. 34). The test included the integration of the AEPS breadboard discharge supply unit, system flow controller card, xenon flow controller, and the HERMeS TDU-1 thruster, shown in Figure 9. The AEPS EIST successfully demonstrated the discharge supply unit functionality while operating the TDU thruster; characterized command accuracy and stability; assessed regulation between the six power modules; and characterized efficiency. The test demonstrated closed-loop system operation during various startup scenarios and across the operating range, characterized oscillation at various points in the system, and characterized flow rate stability under closed-loop control providing data to improve closed-loop stability and performance.

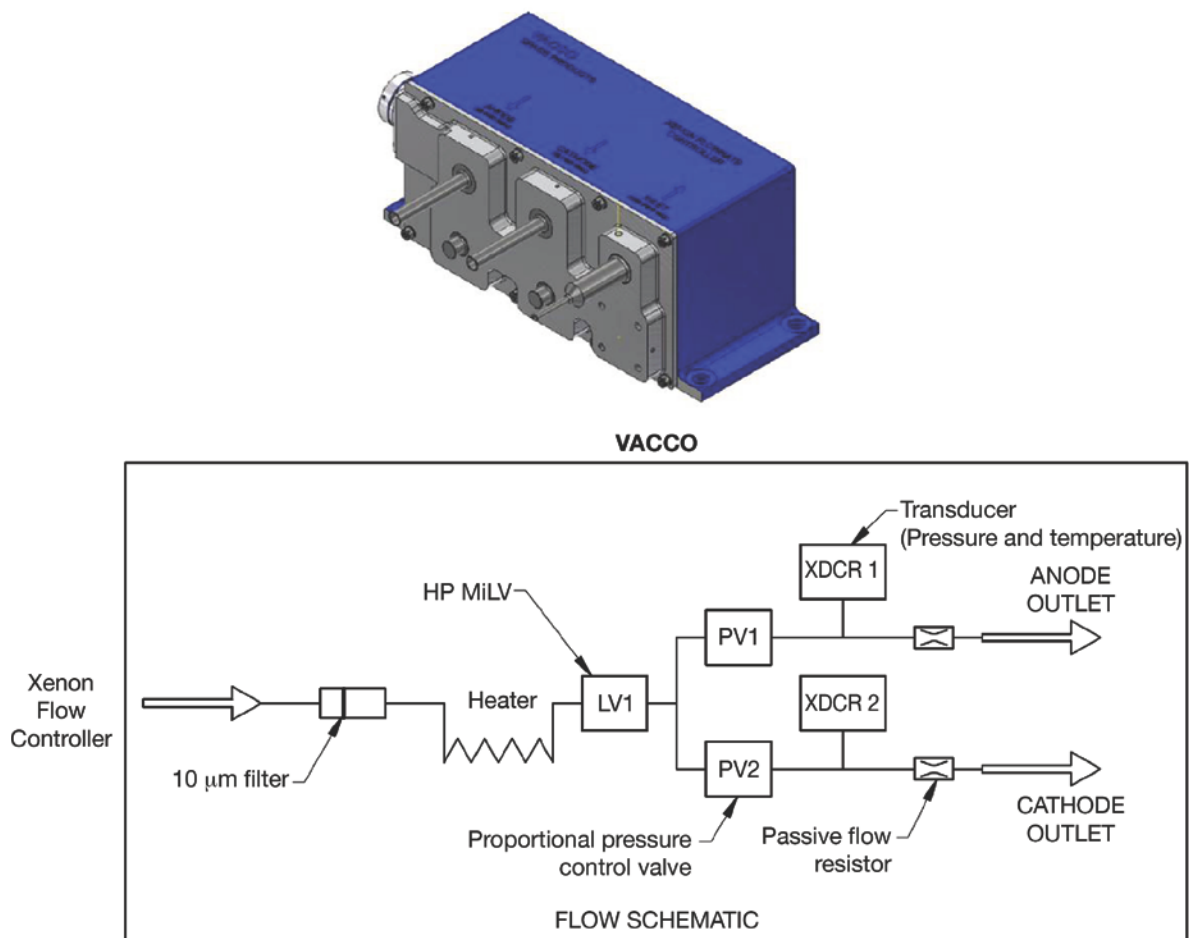
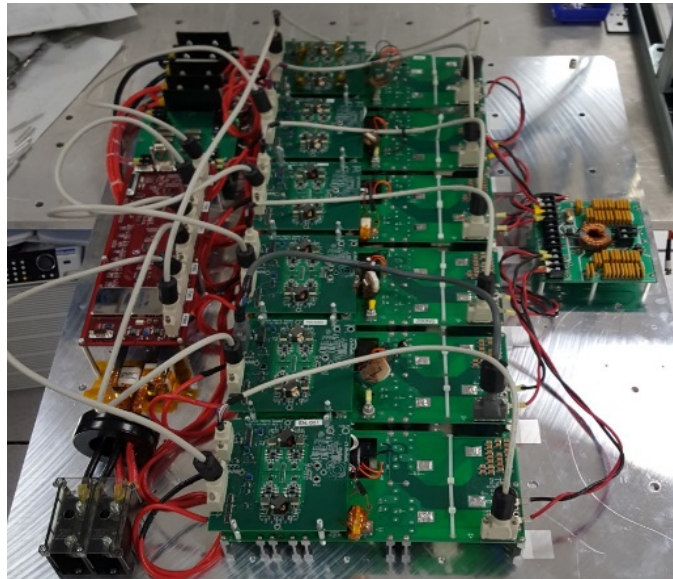
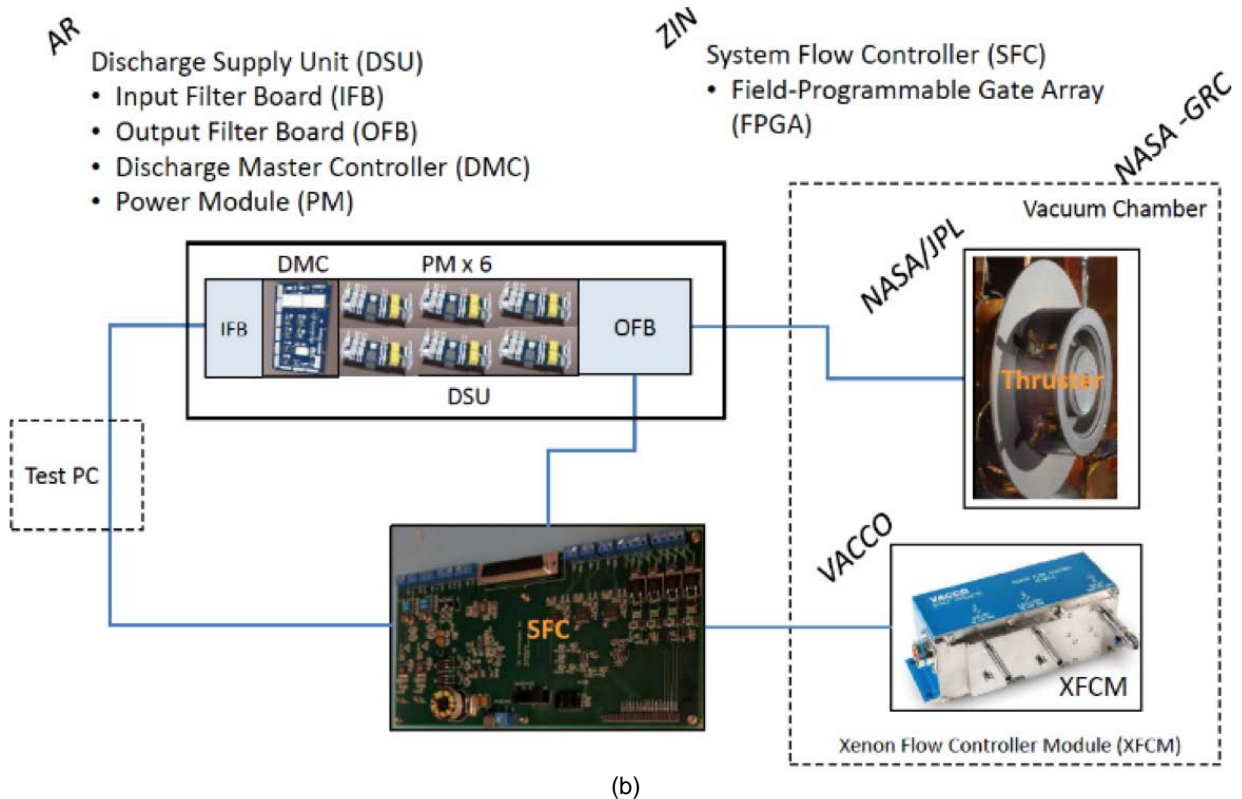

Figure 8.—AEPS Xenon Flow Controller (XFC) EDU flow schematic and design.



(a)



(b)

Figure 9.—Aerojet Rocketdyne (AR) Discharge Supply Unit (a) and (b) AEPS EIST schematic that included AR Discharge Supply Unit, ZIN Technologies System Flow Controller card, VACCO Industries XFCM, and NASA TDU thruster.



## NASA AEPS and Mission Risk Reduction Activities

NASA is utilizing the HERMeS TDU thrusters, laboratory TDU cathodes, and other hardware to perform life qualification and risk reduction testing in support of the AEPS contract and for the mission implementation of the system. This activity began with transition of the HERMeS thruster design and completed test results at the beginning of the AEPS contract. That transition continues, primarily focused on the transition of NASA reliable, long-life hollow cathode heater fabrication processes that were developed under the International Space Station plasma contactor program, utilized to provide flight cathode heaters for Deep Space One and Dawn missions, and being implemented on the NASA's Evolutionary Xenon Thruster—Commercial (NEXT-C) program for flight hardware.

The NASA risk reduction activities are continually evaluated against the evolving AEPS and mission risks. More details of the NASA risk reduction and plasma modeling tasks can be found in References 23, 25, 26, 28 to 31, and 36 to 55:

- Evaluation and material property characterizations of discharge chamber ceramic and other materials, (Refs. 46 and 50)
- Environmental testing of HERMeS TDU thruster,
- Characterizations of HERMeS TDU thruster wear as a function of operating condition; assessing sensitivities to background pressure, magnet field variation, discharge oscillations, and cathode position; and for extended-duration operating segments, (Refs. 24, 28, 29, 37, 47 to 49, and 51)
- Mapping of HERMeS TDU ion velocities to validate inputs for plasma modeling, identify and mitigate erosion mechanisms, and as a nonintrusive way to further characterize background pressure effects, (Ref. 41) and
- Assessing the impact of test facility back-sputtered carbon efflux (evident in images shown in Figure 10) on thruster performance, electrical isolation, and test execution during an accelerated full life test deposition test (Ref. 30).

Significant NASA TDU thruster tests have recently been completed and another has recently started. Following a typical EP thruster life qualification approach, NASA has been performing cycles that include a thruster wear assessment followed by implementation of thruster wear mitigations while increasing the wear testing duration for each subsequent cycle. The first cycle started with a series of short-duration wear segments that resulted in mitigation of the inner front pole erosion through a

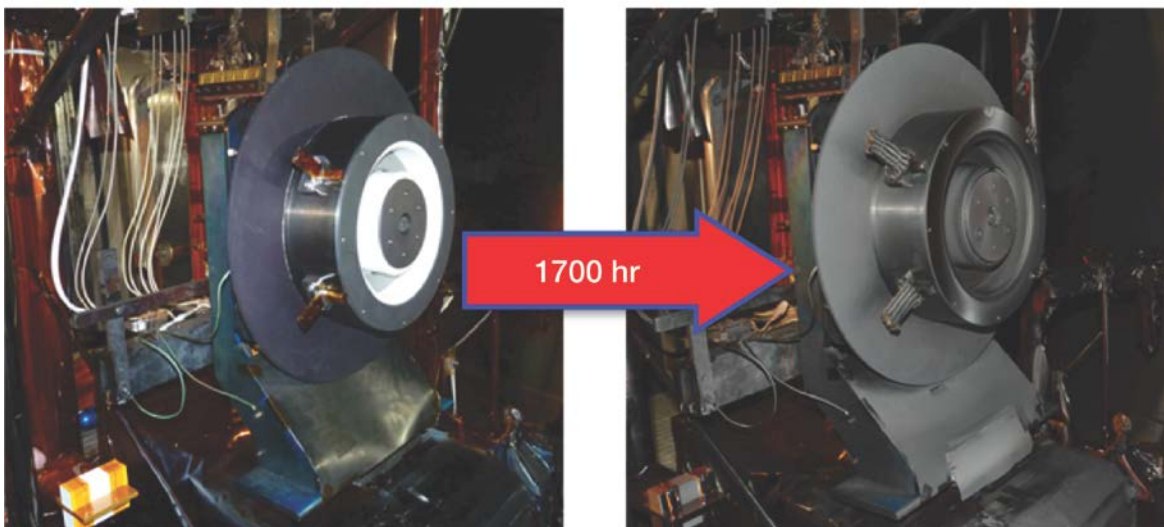

Figure 10.—HERMeS TDU-1 pre-test (left) and post-test (right) of the 1700 hr wear test in VF-5 (Ref. 25).

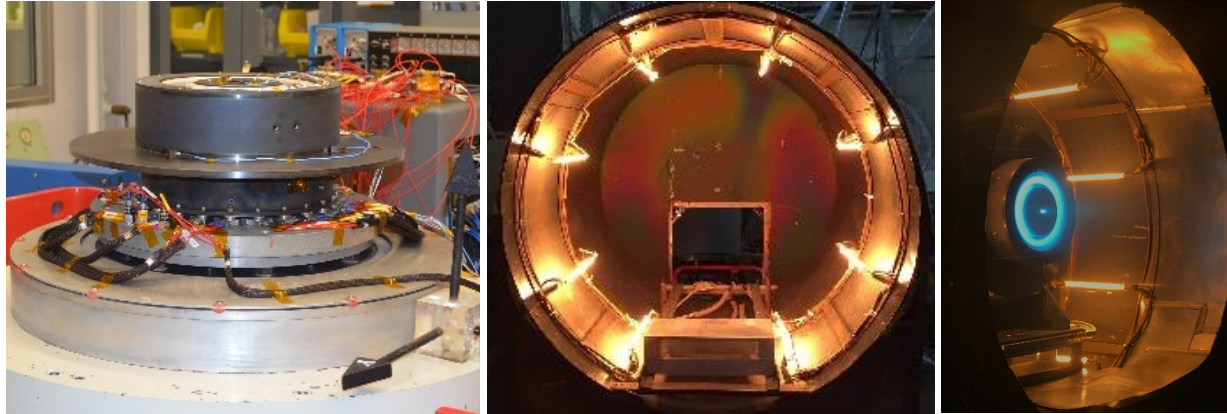

Figure 11.—HERMeS TDU-2 testing at JPL during random vibration testing (left), thermal shroud shakedown test (middle), and initial firing of TDU-2 inside thermal shroud prior to start of thermal cycling (right) (Ref. 36).

combination of an added graphite pole cover and a change to the thruster electrical configuration that ties the cathode to thruster chassis (Refs. 23, 26, and 54). This thruster configuration was subsequently tested for 1700 hr on TDU-1, shown in Figure 10 (Ref. 25). The second cycle again started with a series of short-duration wear segments to assess pole cover and cathode keeper erosion as a function of operating condition. This test resulted in mitigation of the observed cathode keeper erosion by recessing the cathode relative to inner front pole cover downstream surface and increasing the graphite keeper faceplate thickness (Ref. 47). This configuration has recently begun a wear test in VF5 at NASA GRC with a goal to accumulate a total of 5,000 hr on TDU-3.

NASA has subjected TDU-2 to qualification-level dynamic and thermal environments to evaluate thruster design features common between TDU and EDU (e.g., monolithic boron nitride discharge channel, centrally-mounted cathode), to provide data to validate and improve structural and thermal models, and as a pathfinder for EDU thruster dynamic and thermal environment tests. Random vibration testing was performed at the JPL Environmental Test Laboratory as shown in Figure 11. The test was performed with response-limits to simulate the EDU shock isolators. The discharge channel survived the random vibration test. Shock testing was not performed because the TDU does not include the shock isolators that are present on the EDU thruster that are needed to survive the required shock loads. Thermal cycle testing was performed on TDU-2 inside the thermal shroud shown in Figure 11.

NASA is also responsible for performing the requisite plasma modeling of the AEPS EDU and QM/FM thrusters to assess and mitigate thruster erosion mechanisms; evaluate thruster design choices and changes; predict on-orbit thruster performance, operating characteristics, and plume properties; and contribute to thruster life qualification (Refs. 40, 43 to 45). The AEPS thruster life qualification plan is a collaborative effort between NASA and Aerojet Rocketdyne. Aerojet Rocketdyne will conduct an EDU thruster wear test in VF5 at NASA GRC and is expected to accumulate greater than 4500 hr prior to the end of the AEPS contract. NASA will perform thruster component cyclic qualification testing and plans to extend the EDU thruster wear test to 100 percent required lifetime (23,000 hr) in VF5 at NASA GRC. Consistent with a typical electric propulsion qualification effort, plasma modeling and probabilistic failure mode analyses will be used to assess and justify the 50 percent margin (Ref. 56).

## Conclusion

NASA has reaffirmed its commitment to the development and application of high power solar electric propulsion as a key element of future human exploration plans. The recent announcement of a Power and Propulsion Element (PPE) as the first element of an evolvable human architecture to Mars has replaced ARRM as the most probable first application of the AEPS Hall thruster system. The AEPS contract development represents a continuation of STMD-funded efforts first initiated in the in-house,

collaborative HERMeS thruster and HP-120V PPU developments conducted by NASA GRC and JPL. Ongoing advanced technology development work is being performed by Aerojet Rocketdyne under the AEPS contract that is managed by NASA GRC. Under the AEPS contract, Aerojet Rocketdyne is currently designing the engineering-model EP string hardware and has recently completed an early integrated system test and system PDR. Fabrication of the EDU EP string components (Hall thruster, power processing unit, xenon flow controller, and high-voltage harness) will begin with planned EDU hardware and string testing planned in 2018. The AEPS contract has an option phase that can be exercised after CDR for qualification and flight strings that will meet the PPE requirements and target launch date.

## References

1. Smith, B.K., Nazario, M.L., and Cunningham, C.C., “Solar Electric Propulsion Vehicle Demonstration to Support Future Space Exploration Missions,” Space Propulsion 2012, Bordeaux, France, May 7-10, 2012.
2. Congress, “National Aeronautics and Space Administration Transition Authorization Act of 2017,” 2017.
3. HQ, N., “Meeting Agenda and Minutes,” NASA Advisory Council Human Exploration and Operations Committee Meeting, [https://www.nasa.gov/sites/default/files/atoms/files/nac\\_heoc\\_march\\_2017\\_public\\_agenda\\_revb.pdf](https://www.nasa.gov/sites/default/files/atoms/files/nac_heoc_march_2017_public_agenda_revb.pdf), [cited March 28, 2017].
4. Gerstenmaier, W., “Progress in Defining the Deep Space Gateway and Transport Plan,” NASA Advisory Council Human Exploration and Operations Committee Meeting, [https://www.nasa.gov/sites/default/files/atoms/files/nss\\_chart\\_v23.pdf](https://www.nasa.gov/sites/default/files/atoms/files/nss_chart_v23.pdf), [cited March 28, 2017].
5. Free, J., “Architecture Status,” NASA Advisory Council Human Exploration and Operations Committee Meeting, [https://www.nasa.gov/sites/default/files/atoms/files/march\\_2017\\_nac\\_charts\\_architecturejmf\\_rev\\_3.pdf](https://www.nasa.gov/sites/default/files/atoms/files/march_2017_nac_charts_architecturejmf_rev_3.pdf), [cited March 28, 2017].
6. McGuire, M., Hack, K., Manzella, D.H., and Herman, D.A., “Concept Designs for NASA’s Solar Electric Propulsion Technology Demonstration Mission,” AIAA-2014-3717, 50th AIAA/ASME/SAE/ASEE Joint Propulsion Conference, Cleveland, OH, July 28-30, 2014.
7. Manzella, D.H. and Hack, K., “High-Power Solar Electric Propulsion for Future NASA Missions,” AIAA-2014-3718, 50th AIAA/ASME/SAE/ASEE Joint Propulsion Conference, Cleveland, OH, July 28-30, 2015.
8. Muirhead, B. and Brophy, J.R., “Asteroid Redirect Robotic Mission Feasibility Study,” 2014 IEEE Aerospace Conference, Big Sky, MT, March 1-8, 2014.
9. Brophy, J. and Randolph, T.M., “Status of the Asteroid Redirect Robotic Mission (ARRM),” IEPC-2017-031, 35th International Electric Propulsion Conference, Atlanta, GA, Oct. 8-12, 2017.
10. NASA, “NASA Synopsis for NextSTEP BAA Appendix-C: Power and Propulsion Element Studies,” Solicitation NNH17ZCQ006L-S, <https://www.fbo.gov/notices/4a9a70d396472e75e5ad5bca8f6af881>, [cited July 17, 2017].
11. NASA, “NASA Deep Space Gateway (DSG) Concept Power and Propulsion Element (PPE) Request for Information,” Solicitation NNH17ZCQ006L, <https://www.fbo.gov/notices/33368e53181a28d9fb7d9e8582aff8c7>, [cited July 17, 2017].
12. Herman, D.A., et al., “The Ion Propulsion System for the Asteroid Redirect Robotic Mission,” 52nd AIAA/SAE/ASEE Joint Propulsion Conference.
13. Snyder, J.S., et al., “Vibration Test of a Breadboard Gimbal for the NEXT Ion Engine,” AIAA-2006-4665, 42nd AIAA/ASME/SAE/ASEE Joint Propulsion Conference and Exhibit, Sacramento, CA, July 9-12, 2006.
14. Vaughan, D.A., “Gimbal Development for the NEXT Ion Propulsion System,” AIAA-2005-3865, 41st AIAA/ASME/SAE/ASEE Joint Propulsion Conference and Exhibit, Tucson, AZ, July 10-13, 2005.
15. Kamhawi, H., et al., “Overview of the Development of the Solar Electric Propulsion Technology Demonstration Mission 12.5-kW Hall Thruster,” AIAA-2014-3898, 50th AIAA/ASME/SAE/ASEE Joint Propulsion Conference, Cleveland, OH, July 28-30, 2014.

16. Spence, B., et al., "Technology Maturation and Advancement Update of the ROSA/MegaROSA Solar Array," Huntington Beach, CA, May 7, 2014.
17. Mercer, C.R. and et al., "Solar Array Technology Development for Electric Propulsion," Huntington Beach, CA, May 11-14, 2015.
18. Murphy, D., et al., "MegaFlex Solar Array Development and Test – Results from Phase 1 of the NASA Game Changing Development (GCD) Program for Solar Electric Propulsion (SEP) Solar Array Systems (SAS) Program," Huntington Beach, CA, May 7, 2014.
19. Kerslake, T.W., "Advanced Solar Arrays for NASA Electric Propulsion Missions," SciTech 2015, Kissimmee, FL, January 5-9, 2015.
20. Brophy, J.R., "Technology for a Robotic Asteroid Redirect Mission," 2014 IEEE Aerospace Conference, Big Sky, MT, March 1-8, 2014.
21. Herman, D.A., et al., "The Ion Propulsion System for the Solar Electric Propulsion Technology Demonstration Mission," IEPC-2015-008, 30th International Electric Propulsion Conference, Kobe, Hyogo, Japan, July 4-10, 2015.
22. Hofer, R.R., et al., "Development Approach and Status of the 12.5 kW HERMeS Hall Thruster for the Solar Electric Propulsion Technology Demonstration Mission," 30th International Electric Propulsion Conference, Kobe, Hyogo, Japan, July 4-10, 2015.
23. Hofer, R.R., et al., "The 12.5 kW HERMeS Hall thruster for the Asteroid Redirect Robotic Mission," AIAA-2016-4825, 52nd AIAA/SAE/ASEE Joint Propulsion Conference, Salt Lake City, UT, July 25-27, 2016.
24. Kamhawi, H., et al., "Performance, Stability, and Pressure Effects Characterization Tests of NASA's 12.5-kW Hall Effect Rocket with Magnetic Shielding (HERMeS) Thruster," AIAA-2016-4826, 52nd AIAA/SAE/ASEE Joint Propulsion Conference, Salt Lake City, UT, July 25-27, 2016.
25. Williams, G.J., et al., "Wear Testing of the HERMeS Thruster," AIAA-2016-5025, 52nd AIAA/SAE/ASEE Joint Propulsion Conference, Salt Lake City, UT, July 25-27, 2016.
26. Peterson, P.Y., Kamhawi, H., Williams, G.J., and Gilland, J.H., "NASA's HERMeS Hall Thruster Electrical Configuration Characterization," AIAA-2016-5027, 52nd AIAA/SAE/ASEE Joint Propulsion Conference, Salt Lake City, UT, July 25-27, 2016.
27. Katz, I., et al., "Effect of Solar Array Plume Interactions on Hall Thruster Cathode Common Potentials," 14th Spacecraft Charging Technology Conference, Noordwijk, Netherlands, April 2016.
28. Huang, W., Kamhawi, H., and Haag, T.W., "Plasma Oscillation Characterization of NASA's HERMeS Hall Thruster via High Speed Imaging," AIAA-2016-4829, 52nd AIAA/SAE/ASEE Joint Propulsion Conference, Salt Lake City, UT, July 25-27, 2016.
29. Huang, W., Kamhawi, H., and Haag, T.W., "Facility Effect Characterization Test of NASA's HERMeS Hall Thruster," AIAA-2016-4828, 52nd AIAA/SAE/ASEE Joint Propulsion Conference, Salt Lake City, UT, July 25-27, 2016.
30. Gilland, J.H., Williams, G.J., Burt, J.M., and Yim, J., "Carbon Back Sputter Modeling for Hall Thruster Testing," AIAA-2016-4941, 52nd AIAA/SAE/ASEE Joint Propulsion Conference, Salt Lake City, UT, July 25-27, 2016.
31. Conversano, R., Sekerak, M., Hofer, R.R., and Kamhawi, H., "Performance Comparison of the 12.5 kW HERMeS Hall Thruster Technology Demonstration Units," AIAA-2016-4827, 52nd AIAA/SAE/ASEE Joint Propulsion Conference, Salt Lake City, UT, July 25-27, 2016.
32. "Thruster and Power Processing Unit Development for an Advanced Electric Propulsion System Acquisition," Solicitation Number: NNC15ZCH014R, [https://www.fbo.gov/index?s=opportunity&mode=form&id=8f06bbacbbd8c3d2d6c1108d9b0c70ef&tab=core&\\_cview=1](https://www.fbo.gov/index?s=opportunity&mode=form&id=8f06bbacbbd8c3d2d6c1108d9b0c70ef&tab=core&_cview=1), [cited May 21, 2015].
33. Snyder, J.S., et al., "Additional Mission Applications for NASA's 13.3-kW Ion Propulsion System," 2016 IEEE Aerospace Conference, Big Sky, MT, March 5-12, 2016.
34. Jackson, J., et al., "13 kW Advanced Electric Propulsion Flight System Development and Qualification," IEPC-2017-223, 35th International Electric Propulsion Conference, Atlanta, GA, Oct. 8-12, 2017.

35. Cardin, J.M., Cook, W., and Bhandari, R., "Qualification of an Advanced Xenon Flow Control Module," IEPC-2013-382, 33rd International Electric Propulsion Conference, Washington, DC, Oct. 6-10, 2013.
36. Hofer, R. and Kamhawi, H., "Development Status of a 12.5 kW Hall Thruster for the Asteroid Redirect Robotic Mission," IEPC-2017-231, 35th International Electric Propulsion Conference, Atlanta, GA, Oct. 8-12, 2017.
37. Polk, J.E., et al., "Inner Front Pole Erosion in the 12.5 kW HERMeS Hall Thruster Over a Range of Operating Conditions," IEPC-2017-409, 35th International Electric Propulsion Conference, Atlanta, GA, Oct. 8-12, 2017.
38. Polk, J.E., Guerrero, P., Lopez-Ortega, A., and Mikellides, I., "Hollow Cathode Operation with Time-Varying Currents," IEPC-2017-410, 35th International Electric Propulsion Conference, Atlanta, GA, Oct. 8-12, 2017.
39. Guerrero, P., et al., "The Effect of Orifice Size on Lanthanum Hexaboride Hollow Cathode Performance and Thermal Behavior," IEPC-2017-399, 35th International Electric Propulsion Conference, Atlanta, GA, Oct. 8-12, 2017.
40. Ortega, A.L., Katz, I., and Chaplin, V., "Effect of Wave Growth in Non-Thermal Ions on Hall Thruster Electron Transport," IEPC-2017-178, 35th International Electric Propulsion Conference, Atlanta, GA, Oct. 8-12, 2017.
41. Chaplin, V., et al., "Laser Induced Fluorescence Measurements of the Acceleration Zone in the 12.5 kW HERMeS Hall Thruster," IEPC-2017-229, 35th International Electric Propulsion Conference, Atlanta, GA, Oct. 8-12, 2017.
42. Goebel, D.M., Becatti, G., and Polk, J.E., "Life of the Lanthanum Hexaboride Hollow Cathode for the 12.5 kW HERMeS Hall Thruster," IEPC-2017-276, 35th International Electric Propulsion Conference, Atlanta, GA, Oct. 8-12, 2017.
43. Ortega, A.L., Mikellides, I., and Goebel, D.M., "OrCa2D Simulations for Life Assessments of the BaO and LaB6 Hollow Cathode Options in the Hall Effect Rocket with Magnetic Shielding," IEPC-2017-152, 35th International Electric Propulsion Conference, Atlanta, GA, Oct. 8-12, 2017.
44. Ortega, A.L., Mikellides, I., and Chaplin, V., "Hall2De Simulations for the Assessment of Pole Erosion in the 12.5 kW Hall Effect Rocket with Magnetic Shielding (HERMeS)," IEPC-2017-154, 35th International Electric Propulsion Conference, Atlanta, GA, Oct. 8-12, 2017.
45. Choi, M., Yim, J., Williams, G., and Gilland, J.H., "Hybrid PIC Simulation of Backsputtered Carbon Transport in the Near-Field Plume of a Hall Thruster," IEPC-2017-537, 35th International Electric Propulsion Conference, Atlanta, GA, Oct. 8-12, 2017.
46. Kamhawi, H., et al., "Performance and Stability Characterization of the HERMeS Thruster with Boron Nitride Silica Composite Discharge Channel," IEPC-2017-392, 35th International Electric Propulsion Conference, Atlanta, GA, Oct. 8-12, 2017.
47. Williams, G., et al., "Wear Trends of the HERMeS Thruster as a Function of Throttle Point," IEPC-2017-207, 35th International Electric Propulsion Conference, Atlanta, GA, Oct. 8-12, 2017.
48. Pinero, L., "The Impact of Harness Impedance on Hall Thruster Discharge Oscillations," IEPC-2017-023, 35th International Electric Propulsion Conference, Atlanta, GA, Oct. 8-12, 2017.
49. Peterson, P.Y., et al., "Reconfiguration of NASA GRC's Vacuum Facility 6 for Testing of Advanced Electric Propulsion System (AEPS) Hardware," IEPC-2017-028, 35th International Electric Propulsion Conference, Atlanta, GA, Oct. 8-12, 2017.
50. Yim, J., "A survey of xenon ion sputter yield data and fits relevant to electric propulsion spacecraft integration," IEPC-2017-060, 35th International Electric Propulsion Conference, Atlanta, GA, Oct. 8-12, 2017.
51. Huang, W., et al., "Plasma Plume Characterization of the HERMeS during a 1722-hr Wear Test Campaign," IEPC-2017-307, 35th International Electric Propulsion Conference, Atlanta, GA, Oct. 8-12, 2017.

52. Lopez Ortega, A., Mikellides, I., and Jorns, B., "First-principles Modeling of the IAT-driven Anomalous Resistivity in Hollow Cathode Discharges II: Numerical simulations and comparison with experiments," 52nd AIAA/SAE/ASEE Joint Propulsion Conference, Salt Lake City, UT, July 25-27, 2016.
53. Jorns, B., Lopez Ortega, A., and Mikellides, I., "First-principles Modelling of the IAT-driven Anomalous Resistivity in Hollow Cathode Discharges I: Theory," AIAA-2016-4626, 52nd AIAA/SAE/ASEE Joint Propulsion Conference, Salt Lake City, UT, July 25-27, 2016.
54. Jorns, B., et al., "Mechanisms for Pole Piece Erosion in a 6-kW Magnetically-Shielded Hall Thruster," AIAA-2016-4839, 52nd AIAA/SAE/ASEE Joint Propulsion Conference, Salt Lake City, UT, July 25-27, 2016.
55. Herman, D.A., et al., "The Ion Propulsion System for the Asteroid Redirect Robotic Mission," AIAA-2016-4824, 52nd AIAA/SAE/ASEE Joint Propulsion Conference, Salt Lake City, UT, July 25-27, 2016.
56. Dankanich, J.W., Brophy, J.R., and Polk, J.E., "Lifetime Qualification Standard for Electric Thrusters," AIAA-2009-5095, 45th AIAA/ASME/SAE/ASEE Joint Propulsion Conference and Exhibit, Denver, CO, August 2-5, 2009.



