



U.S. Exploration EVA: ConOps, Interfaces and Test Objectives for Airlocks

NASA-JSC EVA Office/J. Buffington

Preface



- NASA is moving forward on defining the xEVA System Architecture and its implications to the spacecraft that host exploration EVA systems
- This presentation provides an overview of the latest information for NASA's Concept of Operations (ConOps), Interfaces and corresponding Test Objectives for Airlocks hosting the xEVA System
- This is presented *from the perspective of EVA, not the spacecraft*
- The ConOps portion is specifically focused on micro-gravity airlock operations and is generally applicable to both LEO and Cis-Lunar space
 - For example, it is written assuming worst-case scenarios for Dormancy and Quiescence which are not typically used on ISS
- The Interfaces are intended to be appropriate for any spacecraft in these destinations
- The Test Objectives are intended for ground-focused evaluations that will help NASA validate Interface and ConOps plans

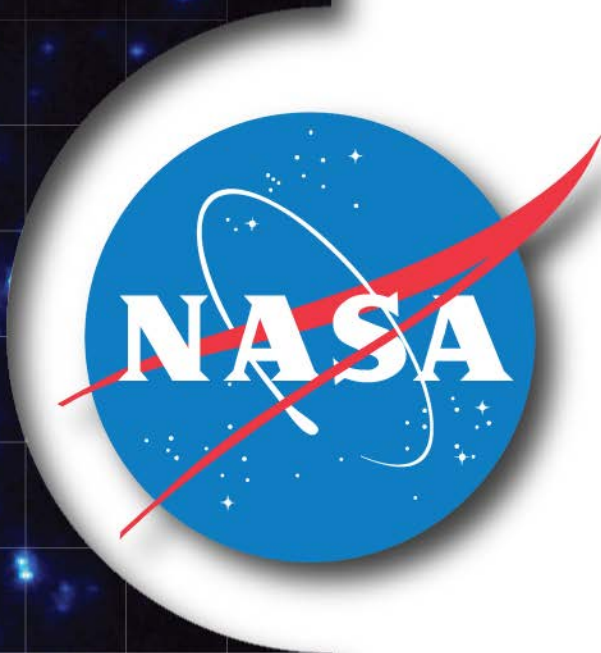
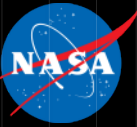

EVA CONOPS

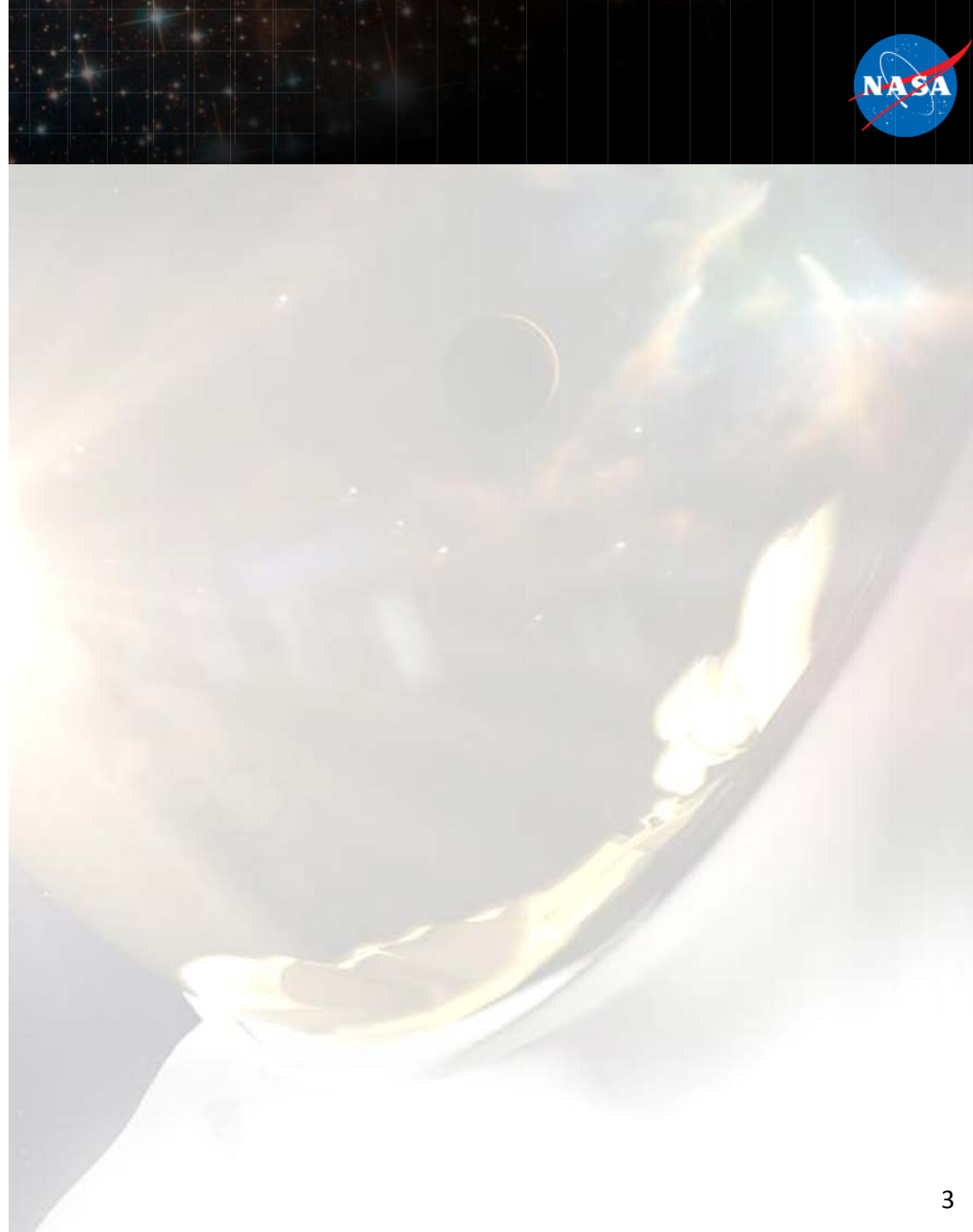

Generic EVA ConOps



- Prior to EVA Day:
 - Exploration suits are launched in a “Dormant” configuration, likely in a separate vehicle from the crew (possibly in the Airlock itself for DSG/T)
 - Assumed to be soft-stowed, unassembled, unwetted with pad-pressure only
 - Once Crew have arrived, Suits are removed from Dormant Stowage configuration
 - Suits are assembled prior to EVA Day and a pressurized On-Orbit Fit Verification is performed (occurrence generally once/6 months after initial OFV)
 - Pre-EVA PLSS consumables charging is done through Special Purpose Charging Equipment (SPCE) housed in the Airlock Element
 - Airlock logistics configuration completed- items not certified for vacuum are removed
 - Assemble EVA Tools and install in bags or on suit, as appropriate
 - Worksite Interface Extenders (WIFs), Foot restraints, and gap spanners for translating along the vehicle
 - Maintenance or science tools
 - Pre-EVA Suit checkouts are completed (unmanned PLSS checkout system)

Generic EVA ConOps



- EVA Day:
 - Drink Bags are filled from elsewhere in the stack and installed in the suit; crew prepare and don biomed equipment
 - Two crew don rear-entry suits in the airlock or adjoining element, donning completed simultaneously if volume allows.
 - Suits are donned using a Rear-Entry Don/Doff Interface (REDDI, rear-entry equivalent of the ISS EDDA)
 - Donning includes
 - In-suit leak-check
 - In-suit comm check
 - Once donning is complete, final stages of prebreathe protocol begin
 - Exact prebreathe protocol depends upon atmosphere crew is saturated at
 - This can be shortened to less than an hour by using xEMU's variable pressure O2 capability and, with full xPGS, a higher delta-P for the beginning of the EVA.
 - IVA crew performs any remaining airlock config tasks they can help with
 - Non-EVA crew transfer to separate element for duration of EVA activities
 - IVA crew conducts EVA support as necessary

Generic EVA ConOps continued



- To be “GO for EVA” (approved for EVA operations), xEMU meets the following conditions:
 - Pressure integrity verified
 - CO2 levels are verified nominal
 - O2 Pressure nominal
 - Cooling system is verified operational
 - Communications established
 - Telemetry is being received by Vehicle and MCC-H
- EVA Crew disconnect from the REDDI fixture and translate into the Crew Lock (assumes a 2-chamber A/L configuration)
- IVA Crew closes/secures inner hatch, isolating the Crew Lock from the Equipment Lock
- The Airlock Element is isolated from the rest of the stack and the C/L is depressurized
- EVA Crew opens the EV hatch (prior to transitioning to PLSS operations)
- EVA Crew transition from Umbilical to PLSS
- EVA Crew egress airlock element through a hatch diameter of at least 1000mm
- EVA Crew is double tethered for safety (No SAFER unless risk assessment shows necessary)
- EVA Crew conducts EVA tasks

Generic EVA ConOps continued



- EVA Crew re-enter the airlock element and repress the Crew Lock using vehicle infrastructure
 - The inner chamber (the Equipment Lock) serves as a redundant volume if there is an inability to secure/repress the Crew Lock
- EVA suits doffed using REDDI
- Life support units are serviced and recharged
- Between EVAs, suits are soft stowed or stored on the Rear-entry Don/Doff Interface in the Equipment Lock
- Quiescent Stowage capability is intended to provide for two (2) years of acceptable stowage between uses
 - The design has to meet this period without direct, in-person human intervention
 - This supports ConOps of 1 Flight/Year to DSG/T and ensures the EVA System is not lost if there is a delayed flight

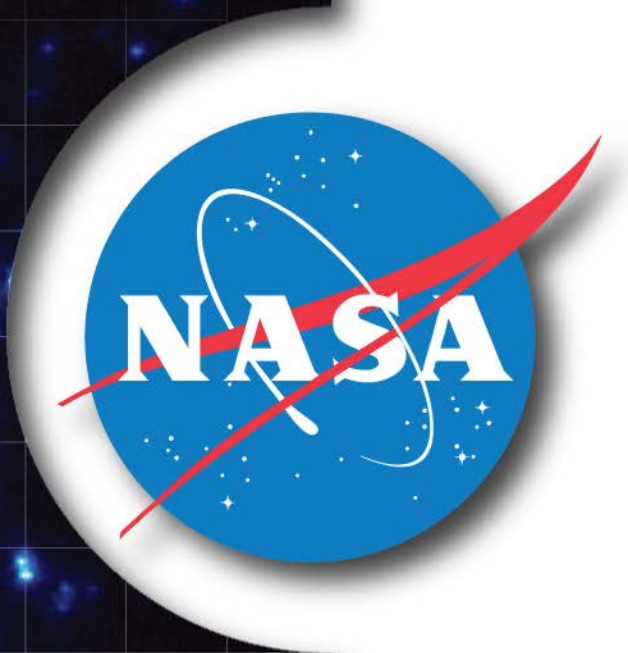
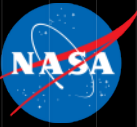

INTERFACES

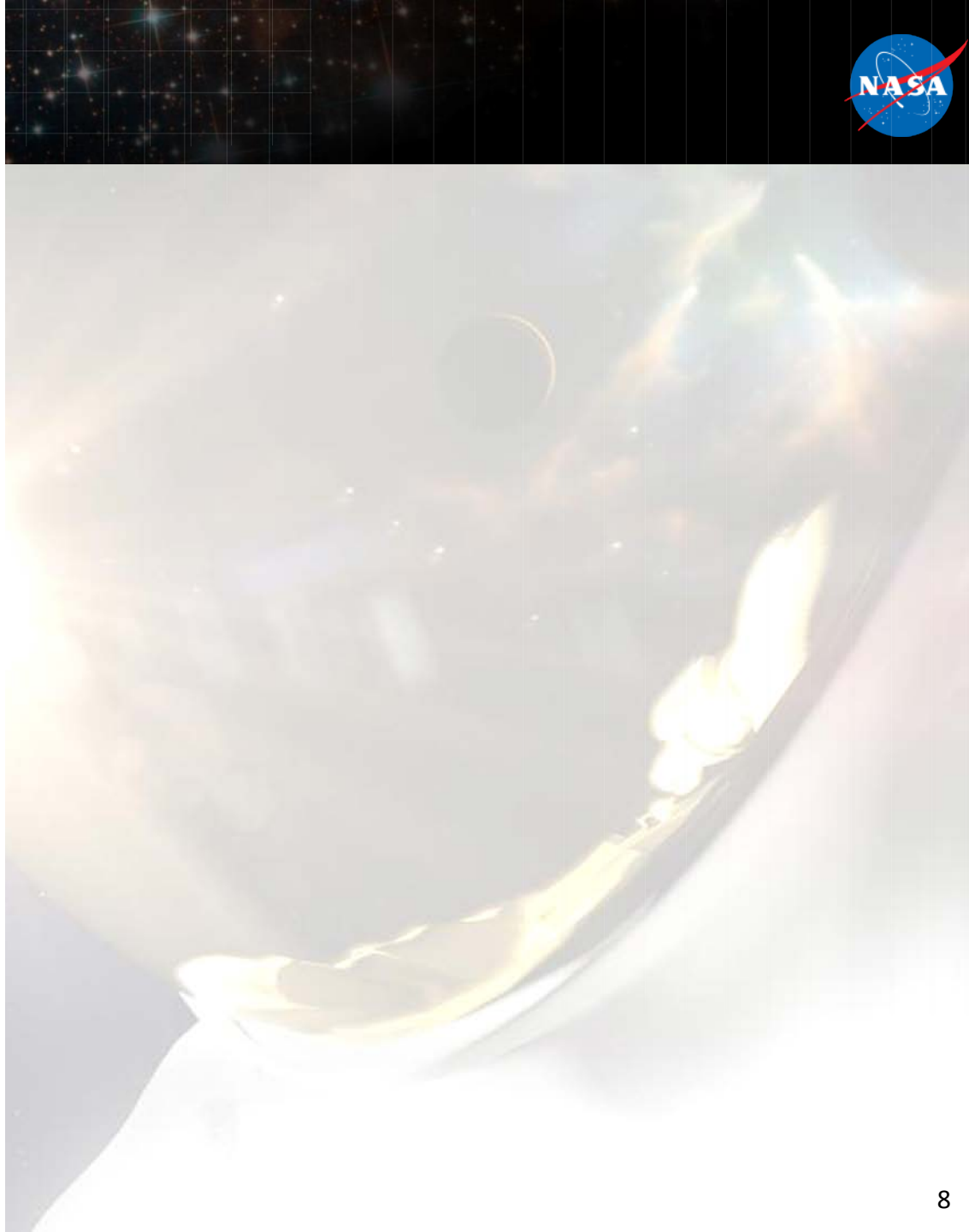

EVA System Development Approach



- The general approach to NASA's Exploration EVA System Reference Architecture prioritizes reducing/mitigating risk to ISS EVA Capability while providing incremental capability for future exploration missions
- By design, the xEVA System Reference Architecture is vehicle/transportation system independent
 - This allows EVA to provide all vehicle architecture teams/trades with the same set of EVA interface inputs
 - This allows EVA to create commonality whether the elements and components are designed by international partners, US commercial entities, or NASA internal teams
- Needs describe the general utility functions in terms of quality, rate, level, volume, amount, etc

Airlock Interfaces Approach



- These slides reflect the needs of NASA's xEVA System but does not provide the Airlock-specific solution- this allows each airlock team to solve problems associated with plumbing, wiring, outfitting, etc in their own way
- NASA EVA is *not* specifying the detailed design solution for the SPCE at this point either
 - SPCE is not the long lead item and is not needed until the xEMU PLSS detailed designs are complete
 - For example: There is little value in having vehicle providers focus on point solution designs for “EVA Battery Chargers” and other rack-mounted support equipment:
 - » The interface between the Battery Charger and the EVA Suit is not trivial and yet is not a significant driver to the Vehicle/Airlock element design
- What is critical to understand is the vehicle builder's perspective on providing utilities up to the back of the EVA SPCE and the supporting items such as suit rear entry don-doff interfaces
- As cis-lunar stack elements and the EVA Systems' flight development plans mature, EVA SPCE will be developed that supports a common approach through Phase 1 and the follow-on destinations and spacecraft

General EVA Interfaces Checklist

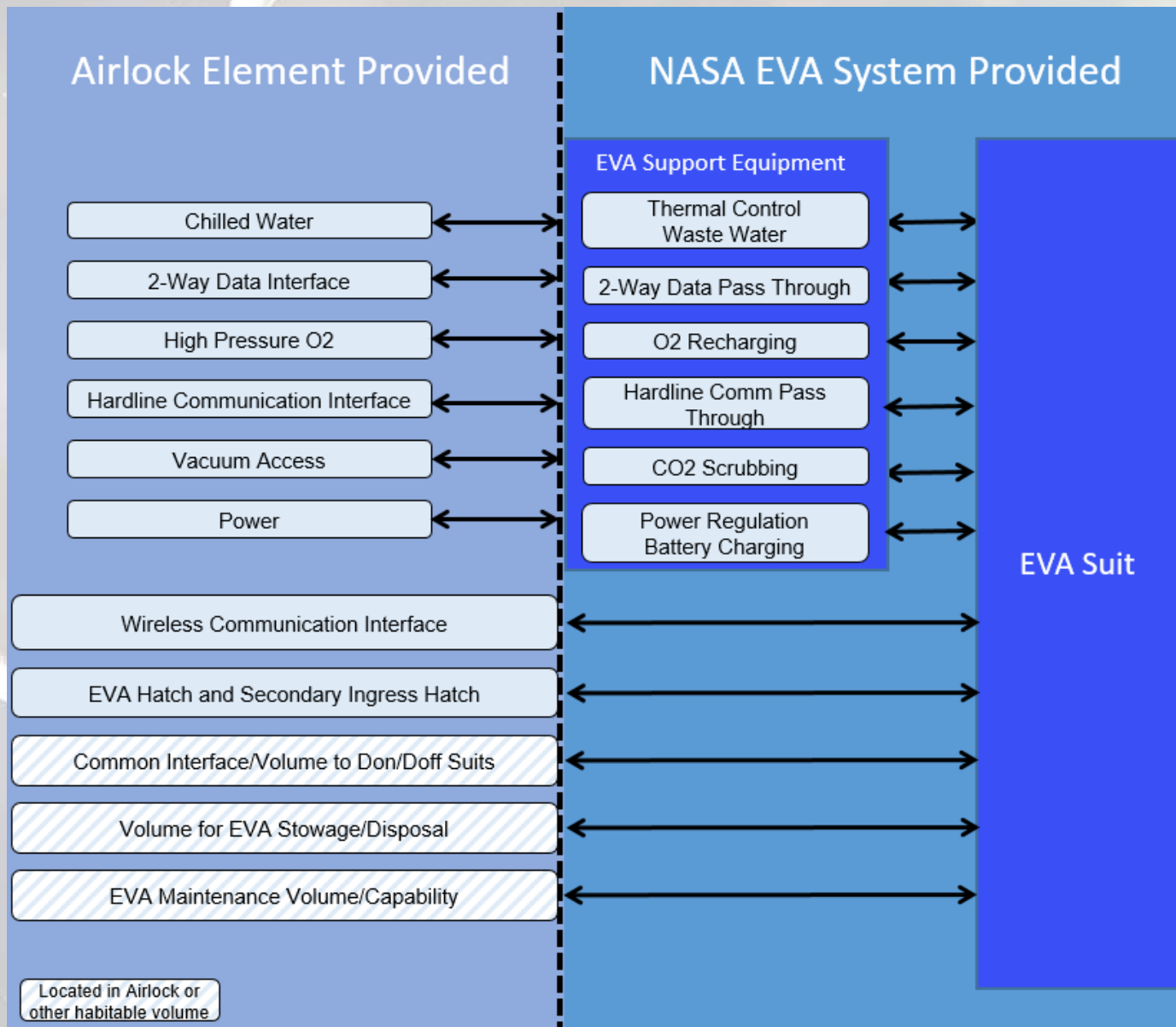

Logistics Assumptions



- Resources and equipment to support full US EVA Capability are built assuming 3 U.S. xEVA Suits on orbit with 2 being used per EVA
- EVA Logistics needs are based upon 10 xEVA System EVAs
- NASA would provide any SPCE needed to go between the general airlock utility services and the exact, specific output needed by the NASA EVA suit
 - Enables maximum flexibility for airlock developer while also allowing for the independent definition and detailed development of the US EVA SPCE hardware
- Umbilical Interface Panels for International Partner-provided and NASA-provided EVA suits could be separate or combined
 - Allows Partners to manage and develop their detailed suit interfaces without over-complicating the design of each Partner's SPCE hardware
- Double Safety Tethers assumed vs. SAFER (Safety discussion needed)

NASA EVA System Mass/Volume Estimates



- NASA EVA Suits and some of the logistics items could be stowed in an airlock element or in other habitable volumes
- Support equipment will probably need to be mounted in the airlock element to support EVA prep and post activities
- Note: Some studies assume 2 vs. 3 suits (3 shown here)

NASA EVA Elements	Total Mass	Stowed Volume*
EVA Suits (qty 3)	453 kg	1.75 m ³
Logistics/consumables for 2 CMs (drink bags, thermal comfort garments, and MAGs)	48 kg	0.47 m ³
EVA Support Equipment (incl. permanent HW)	179 kg	1.1 m ³
EVA tools (common tools and EVA µg equipment)	121 kg	1.8 m ³
Handrails, WIFs, APFRs	140 kg	external
Spares** (TBD)	-	-
Total	941 kg	5.1 m³

*Don/Doff Volume not included (can be shared)

**Spares, Phase 1 kits, Orion LEA suits, external equipment not included

NASA Exploration EVA Airlock Volumes



- Interface/Volume to Don/Doff Suits (EVA prep/post servicing)
 - Trade available for NASA's Exploration EVA Suit to use the Orlan Don/Doff Structural Interface
 - Trade available to Don/Doff in locations other than the Airlock
 - It is assumed the Equipment Lock portion will be used (dual chamber airlock)
 - Minimum $\sim 3.5 \text{ m}^3$ assuming serial donning ($\sim 7 \text{ m}^3$ for simultaneous donning)
- Volume for EVA Stowage
 - Stowage volume for 3 suits = $\sim 1.75 \text{ m}^3$
 - Some of this volume can be combined with the Volume to Don/Doff Suits
 - Trade available to stow EVA hardware in locations other than Airlock
- Volume for NASA-provided EVA SPCE, Logistics, Common vehicle and μg tools
 - $\sim 1 \text{ m}^3$

EVA Needs for Element Translation Paths (μg)



- Further refinement of cis-lunar stack vehicle concepts with element providers will lead to EVA Translation Path analysis and definition
- These will consider Task Definition, Stack Layout, Robotic Interface locations and translation and reach envelopes
- Examples of these analysis include:

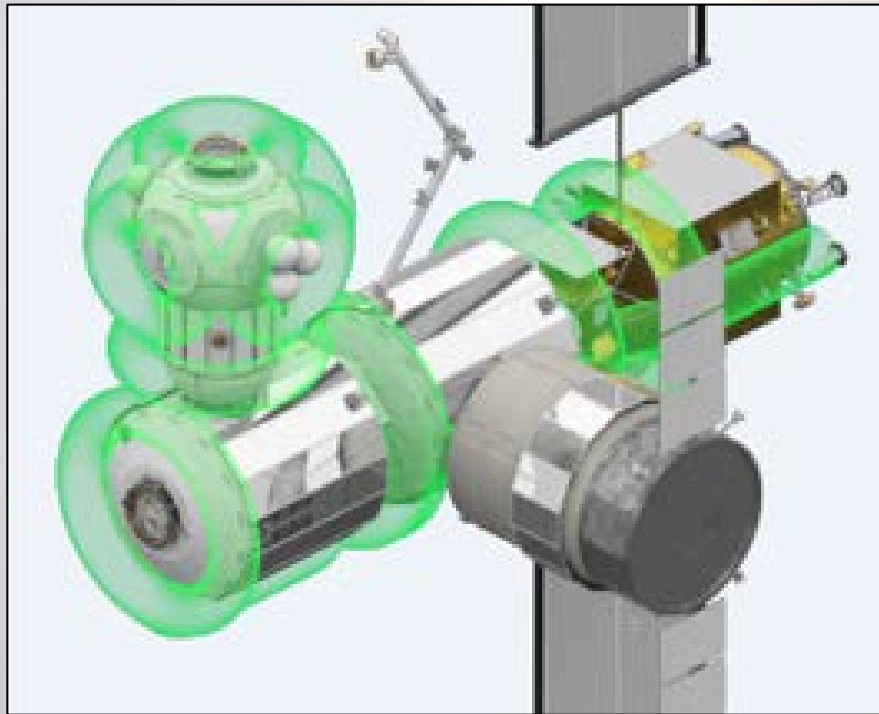

EVA Translation Corridors (green cylinders)

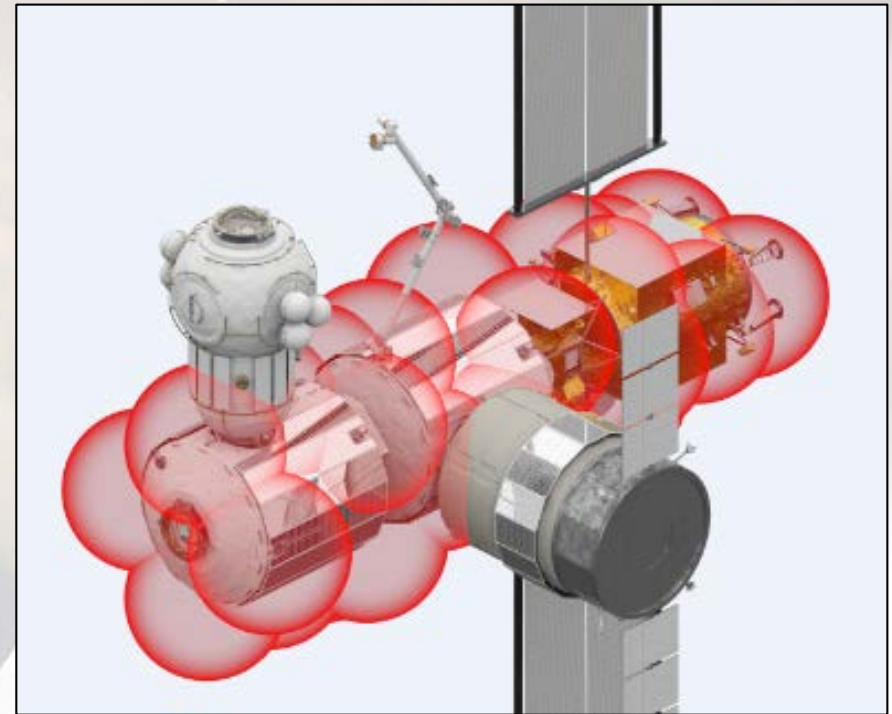

EVA Foot Restraint Reach (red spheres)

Element EVA Translation Path/Worksite Analysis



- Individual modules/elements can be “unrolled” to show flattened, 2D maps for various combinations of assumptions:

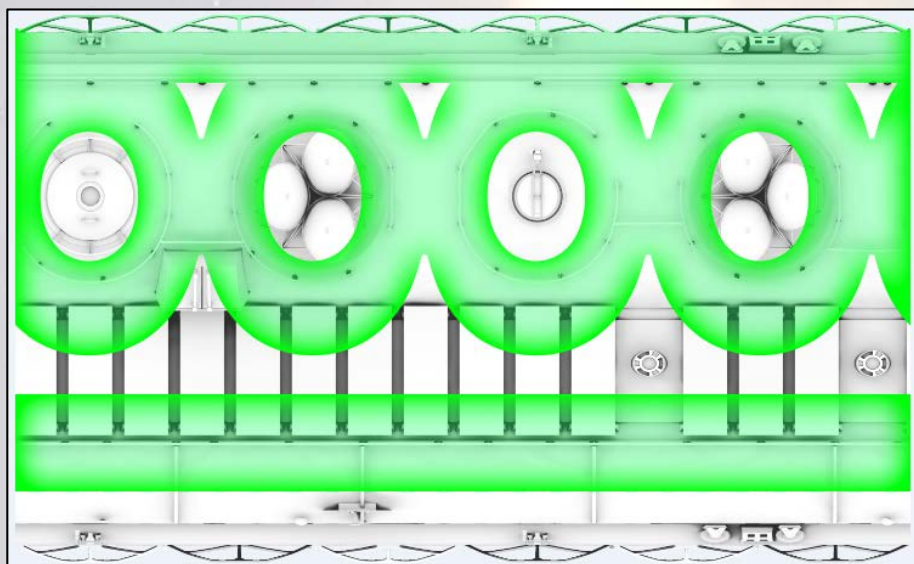

2-D Z-Axis EVA Translation Path Corridor on Airlock Concept



2-D X-Axis EVA with APFR Access Envelopes

Element Robotics Assisted EVA Translation/Worksite Analysis



- Stack level analysis can also demonstrate needs for EVA Translation and Worksite reach and access are met using Robotics assistance
- Overlap and reach/access rules are layered on top of arm geometry/kinematics limits
- These analysis can also be used to back-calculate minimal acceptable quantities of robotic base points with redundancy rules



Robotically Assisted EVA with APFR Access Envelopes

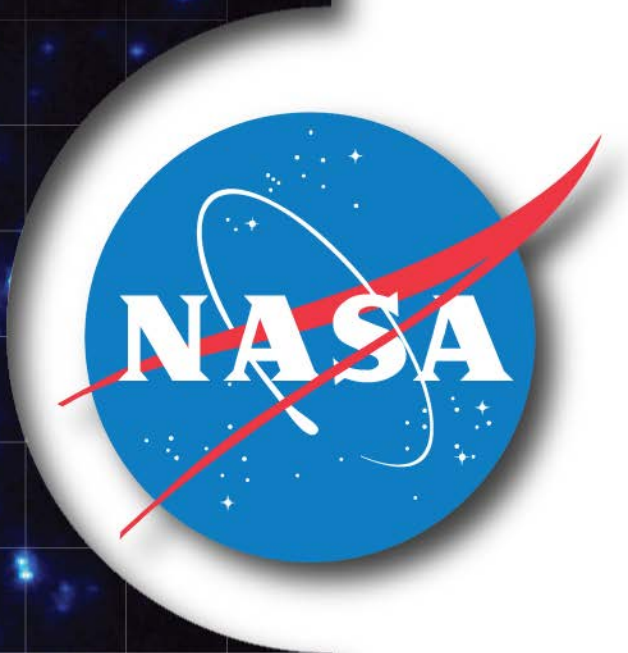
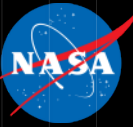

EVA GROUND TEST OBJECTIVES



EVA Objectives for Ground Eval of A/L's



- Evaluate EVA Operational Volume
 - Determine free volume available to conduct EVA prep/post activities
 - Determine free volume available for suit donning and doffing
 - Determine free volume available for suited crew and tools in airlock prior to egress
 - Evaluation: Analysis
- Evaluate EVA Airlock Interfaces
 - Evaluate placement of EVA umbilical panel with respect to reach and access for suited and unsuited operations (Ease of use, accessibility, visibility)
 - Evaluation: Analysis
- Evaluate EVA Stowage Volumes
 - Evaluate volume allocated for EVA suit and support equipment stowage (Dimensioned stowage volumes and relative locations in module)
 - If stowage is distributed, determine what volumes are available in each location and determine spatial relation between locations
 - Evaluation: CAD analysis and/or inspection of vehicle mock-up

EVA Objectives for Ground Eval of A/L's



- Evaluate EVA Hatch Translation
 - Evaluate size of unrestricted hatch translation corridor (hatch diameter, less any hinges or other intrusions into translation path) for primary egress/ingress
 - Evaluate size of unrestricted hatch translation corridor (hatch diameter, less any hinges or other intrusions into translation path) for secondary egress/ingress
 - Evaluation: Analysis
- Evaluate EVA Translation Path
 - Evaluate handrail size, spacing, and location to enable access to EVA worksites on the module and other stack locations (Worksite accessibility, ease of use (within minimum suited reach for CM population and form factor of rail compatible with gloved hand)
 - Evaluation: Analysis, Inspection, Test in NBL or VR lab
- Evaluate IV Support System (minimize number of computers/monitors required for operations)
 - Evaluate EVA task/timeline tracking (including pre and post EVA)
 - IV tracking of EV suit data and consumables
 - Hardware needs for workstation

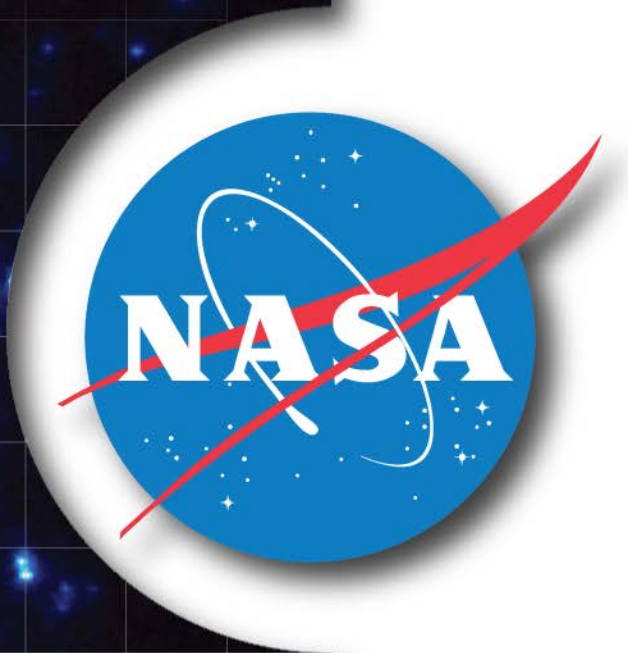
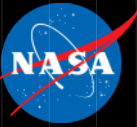

CONCLUSIONS

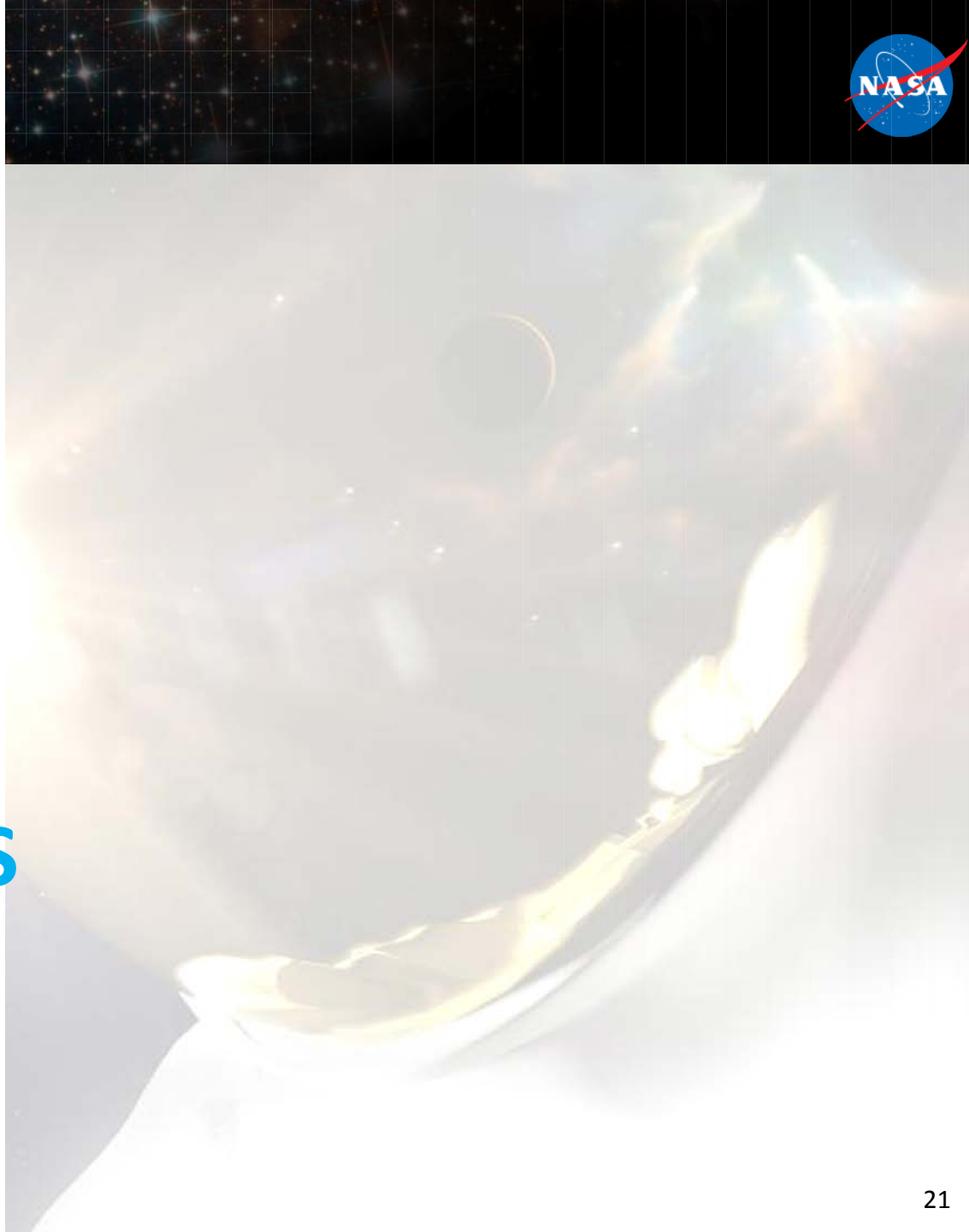

Conclusions



- NASA's progress in defining the xEVA System Architecture allows the Agency to support Vehicle and Airlock Element providers in ways that facilitate spacecraft design
- This presentation provides a starting place for Airlock Concept of Operations (ConOps), Interfaces and corresponding ground Test Objectives for Airlocks hosting the xEVA System in microgravity
- Vehicle concept developers, Design Reference Mission analysts and other spacecraft systems interested in integrating with EVA should prioritize the impacts of routing utilities up to the "back" of SPCE as the interface point between the xEVA System and the spacecraft – see Backup for detailed information

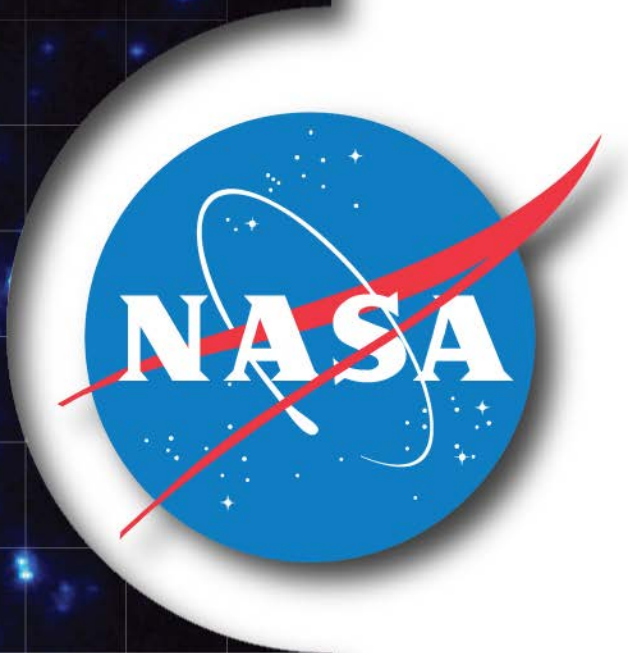
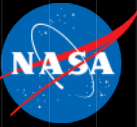

BACKUP

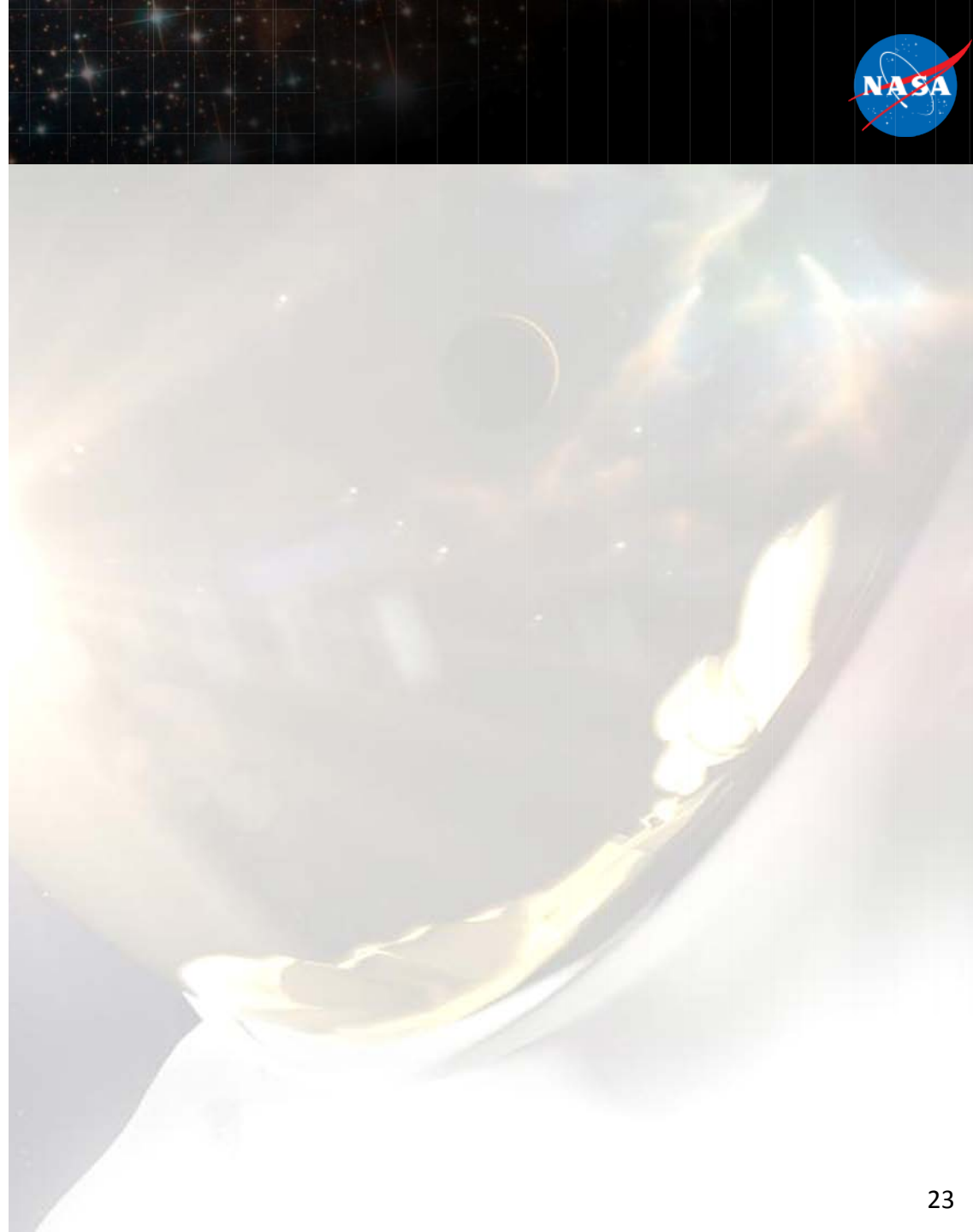

Contingency Ingress Hatch

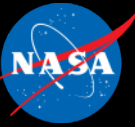

- Goal: Articulate a philosophy on contingency ingress for US EVA on a stack
- While not all vehicle or ingress/egress designs require both a primary and a secondary EVA hatch, an analysis of failure modes could reveal the need when coupled with program-specific choices for human rating and redundancy/fault tolerance strategies
- Fault tolerance should be included in detailed mechanism designs; however, there are some failure modes that may not be able to be mitigated without adding a secondary hatch
- Hatches must allow a pressurized suited crewmember to exit and enter the vehicle
- Sufficient access and free volume will be needed to allow the crew to perform nominal EVAs, as well as contingency ingress operations such as a hatch failure or a failure to repress

Contingency Ingress Path



- There are three conceptual options for conventional airlock volumes:
 - A stack with a “Single Chamber” airlock element
 - This is operationally similar to “Capsule Based EVA” such as the ARCM baseline, though the size might allow for nominal Exploration EVA Suits
 - A stack with a “Dual Chamber, Conjoined” airlock element
 - This is operationally similar to the Joint Airlock on ISS, providing a separate crew and EVA equipment lock which can each function as an airlock in the event of a hatch or repress failure
 - A stack with a “Dual Chamber, Separately Located” airlock element
 - Airlock and Orion (this incurs other risks such as isolating the IV crew, Orion preparation, volume, translation paths, and umbilical transition interfaces; Orion may not travel with Mars transit habitat)
 - Note that a full EVA suit cannot currently make it through the Orion side hatch without modifications to both hatch mechanisms, IVA translation aids, and the EVA system
 - Airlock and Habitat element (this incurs other implications such as equipment designed to go to vacuum, umbilical interfaces, preparation, external hatch access, etc.)
- EVA assumes that a cislunar stack will have “Dual Chamber, Conjoined” airlock element

EVA Needs for Translation Paths (μg)



- Further refinement of cis-lunar stack vehicle concepts with element providers will lead to EVA Translation Path definition.
 - Task Definition
 - External vehicle maintenance: PDR-level vehicle design concepts should reveal if there are any stack failures EVA may be used to mitigate
 - External payload installation, removal or interaction: Architecture maturation should identify if there are any needs for EVA interaction with payloads
 - Interaction with other spacecraft or docked objects: Mission scenarios will determine which docking interfaces EVA should be able to translate to/across
 - Other contingency scenarios: Cis-lunar stack utilization/mission assurance analysis will determine if there are any other contingencies which require EVA for mitigation
 - Examples may include failure of returning excursion vehicles to dock/seal
 - Stack design layout and CAD models
 - Many items should not be designed to withstand EVA kick-loads, further definition of these items and their placement will help determine remaining locations for handrails and translation corridors
 - Other external hardware which may pose hazards to EVA Crew (such as comm antennas, moving solar arrays, ejection paths, etc.) may be categorized as keep-out zones which will also influence the placement of the EVA Translation Path hardware
 - Robotic interface locations and reach envelopes
 - How far robotics can reach, grapple, and interact with EVA Crew could alter EVA Translation path design

General Airlock Assumptions



- Suit consumables are replenished from vehicle systems
 - A cis-lunar microgravity airlock must have umbilical services to provide EVA capability for 2 crewmembers (pre-breathe and suit recharge)
 - No in-flight generated high pressure O₂ unless trade shows favorable with increased number of EVAs
 - A later large Mars hab would have closed-loop ECLSS with the demonstration of the high pressure oxygen recharge capability included
 - Interfaces could be compatible with suits from US and RS providers (these suits will likely have different power supply voltages, high pressure O₂ supply, water with silver biocide, and CO₂ removal needs)
- Airlock equipment is designed to function nominally while exposed to vacuum
 - Some exceptions may include battery chargers (not used during depress/vacuum ops, but designed to operate after going to vacuum)
 - This allows airlock equipment to stay in the depressurizable volume (if other equipment is stowed in airlock and not designed to go to vacuum, it will need to be transferred by the crew)
- Airlock depress/repress services provided by vehicle
 - From a long term architecture perspective and extensibility to future destinations, an airsave pump is assumed to be present and used for all EVAs
 - Further trades and adjustments in the ConOps (frequency of EVAs) may allow us to remove this, but is considered unlikely (break even point is dependent on stack architecture and can be included in trades)
 - Any pump must be sized to accommodate depress rates balancing crew time, physiological needs, power draw, and thermal impact to the stack
- EVA suits will require on-orbit routine maintenance
 - Volume for logistics and spares (dependent on manned pressurized time)

General Airlock Assumptions



- Stack/airlock must address where the prebreathe takes place - either the airlock needs to be big enough for prebreathe at 10.2 psia or part of the vehicle stack must go down to 10.2 psia depending on prebreathe protocol
 - Current prebreathe protocols include In-Suit Light Exercise – though these motions are relatively minor, a volume as small as the ISS crewlock simply does not accommodate two crewmembers for up to 4 hours doing any kind of motion
 - Though not the only way to do it, this problem was addressed on ISS by using the EVA Equipment Lock as a larger volume for suit servicing, donning/doffing and prebreathe
 - Pre-breathe durations and volume necessary may drive the airlock to a larger volume or to a dual chamber system
 - Minimizing the airlock volume for consumables means pre-breathe may need to be conducted in another volume

NASA Exploration EVA Airlock Interfaces



Per this diagram, NASA has placed preliminary needs using the following Structure/Template:

- Utility/Interface (The utility or resource being defined)
 - Value/parameter/service at the needed quality, rate, or level
 - Volume/amount/quantity to be used per suit per a certain number of EVAs

Using the above template, the following interfaces are defined:

- Power
 - Umbilical Power (hardline during IV Suited Ops)
 - Average power draw during EVA prep: 400 W; Peak 900 W
 - Battery Charger Power (EVA prep/post servicing)
 - 40 W idling; Peak 110 W
- High Pressure O2 Recharge (EVA prep/post servicing)
 - 3000 psia O2 @ 99.5% O2 (MIL-PRF-27210G Type I, 99.5% O2 with balance of N2/Argon + allowable contaminants in Table I of the mil-spec)
 - Cleanliness 200A
 - Total O2 needed for 10 EVAs:
 - 140 lbm (prebreathe, fit verification, recharge)

EVA System O2 Demands



- For the purposes of this assessment, EVA O2 Demand is defined as any event that causes the EVA System to draw upon oxygen resources stored directly in a tank or through the transfer medium of the cabin atmosphere
- The following line items are representative events that cause EVA O2 Demand:
 - Suit Maintenance (such as ALCLR Loop Scrub on ISS)
 - On-Orbit Fit Verification (OFV)
 - OFV's only occur 1+ per crew for their time on orbit, NOT every EVA a given crew member conducts
 - The number of occurrences change per DRM (long duration, partial gravity, etc.)
 - Prebreathe Protocol gas loss (changes per DRM)
 - Cabin Atmosphere for Airlock repress (whatever is not reclaimed)
 - Residual air after airlock depress (gas loss vented after air reclamation)
 - EVA Consumables *lost during the EVA itself*
 - xEMU Suit Leakage and Met Rate

NASA Exploration EVA Airlock Interfaces



- Water
 - For the purposes of architecture evaluation and consumables estimates EVA assumes beyond LEO Exploration EVA Systems use water as a utility consumable for cooling of the EVA Crewmember during the EVA (drinking water assumed to be included in everyday IVA water consumption)
 - JSC-66695 EMU Water Quality Spec as reference
 - Cooling water recharge volume of 1 lbm water/hour per EVA crewmember (160 lbm per mission assuming 10 EVAs)
 - Biocide
 - A trade is ongoing on preferred Biocide – Either Silver nitrate 0.3-1ppm in the feedwater supply or Iodine 0.5-6 ppm; Whichever is selected, a goal is to achieve a common Biocide
 - Cooling Water (hardline during IV suited ops prep/post servicing)
 - The temperature of the cooling water received from the Airlock for return to each xEMU will not be greater than eighty-eight (88) degrees Fahrenheit at a flow rate of 187 lbm/hr
 - The temperature of the cooling water received from each Suit is not greater than ninety-eight (98) degrees Fahrenheit at a flow rate of 187 lbm/hr
 - Waste Water (EVA prep/post servicing)
 - Many options are acceptable, including waste water drain to either a consumable bag or a vehicle receptacle. The rate needed is a maximum of 30 lbm per hour against a back pressure of up to 8 psig per suit

Consumables for 10 EVAs



Consumables per EVA Crewmember per EVA	
High Pressure (3000 psi), High Purity O2	$1.7 * 2 \text{ crewmembers} * 10 \text{ EVAs} = 34 \text{ lbm}$
Low Pressure, High Purity O2	$5.13 * 2 * 10 = 102.6 \text{ lbm}$
Low Pressure, Air	? lbm (cabin depresses per vehicle)
Water	$8 * 2 * 10 = 160 \text{ lbm}$
Power	TBD

Consumables per EVA Crewmember per Suit Maintenance and OFV	
High Pressure (3000 psi), High Purity O2	0 lbm (1/month)
Low Pressure, High Purity O2	$0.15 \text{ (1 On-orbit Fit Verification/mission per crewmember)} * 2 \text{ crewmembers} = 0.3 \text{ lbm}$
Low Pressure, Air	?

Total Consumables per mission (10 two crewmember EVAs, two OFVs)	
High Purity O2	136.9 lbm or ~140 lbm
Water	160 lbm

- Vacuum Access (support for CO₂ Removal and Regeneration during IV Suited Ops)
 - Vacuum source capable of providing a vacuum of <0.1 torr
 - Volumetric flow rate >1150 lpm (single flow rate addressing two suits) at 1.6 torr
 - Vacuum source capable of tolerating O₂, CO₂, H₂O, and NH₃
 - Q_{met} = 400 BTU/hr (metabolic rate for each crew member)
 - CO₂ = 37 g/hr per suit => 74 g/hr total
 - H₂O = 44.3 g/hr per suit => 84 g/hr total
 - Used for ~3 hours prior to EVA, 1 hour post (supports suited IV operations including EVA Prebreathe and post-EVA doffing)

NASA Exploration EVA Airlock Interfaces



- Communication Interfaces: EVA Assumes all stack elements are outfitted with infrastructure/utility that will support deployment of both IVA and EVA nodes for wireless and hardline comm.
 - Wireless Communication Interface
 - UHF and 802.11 Hi-Bandwidth
 - Hardline Data and Communication
 - 2-Way Data Interface
 - Hardline Communication Interface (hardline during IV suited ops)