

(12) **United States Patent**
Bradley

(10) **Patent No.:** **US 9,902,446 B2**
(45) **Date of Patent:** **Feb. 27, 2018**

(54) **LOCOMOTION OF AMORPHOUS SURFACE ROBOTS**

(71) Applicant: **The United States of America as represented by the Administrator of the National Aeronautics and Space Administration, Washington, DC (US)**

(72) Inventor: **Arthur T. Bradley, Yorktown, VA (US)**

(73) Assignee: **THE UNITED STATES OF AMERICA AS REPRESENTED BY THE ADMINISTRATOR OF NASA, Washington, DC (US)**

(*) Notice: Subject to any disclaimer, the term of this patent is extended or adjusted under 35 U.S.C. 154(b) by 135 days.

(21) Appl. No.: **14/986,797**

(22) Filed: **Jan. 4, 2016**

(65) **Prior Publication Data**
US 2016/0114842 A1 Apr. 28, 2016

Related U.S. Application Data
(62) Division of application No. 14/189,019, filed on Feb. 25, 2014, now Pat. No. 9,229,451, which is a division (Continued)

(51) **Int. Cl.**
G01C 22/00 (2006.01)
G05D 1/00 (2006.01)
(Continued)

(52) **U.S. Cl.**
CPC **B62D 57/02** (2013.01); **B62D 57/00** (2013.01); **B62D 57/021** (2013.01); **B64G 1/16** (2013.01); **G05D 1/021** (2013.01); **Y10S 901/01** (2013.01)

(58) **Field of Classification Search**
None
See application file for complete search history.

(56) **References Cited**

U.S. PATENT DOCUMENTS

5,492,814 A * 2/1996 Weissleder G01N 33/5434 428/402
5,788,002 A 8/1998 Richter
(Continued)

OTHER PUBLICATIONS

An Articulated Universal Joint Based Flexible Access Robot for Minimally Invasive Surgery J. Shang, D.P. Noonan, C. Payne, J. Clark, M.H. Sodergren, A. Darzi and G.-Z. Yang, 2011 IEEE International Conference on Robotics and Automation Shanghai International Conference Center May 9-13, 2011, Shanghai, China.*

(Continued)

Primary Examiner — Jean-Paul Cass
(74) *Attorney, Agent, or Firm* — Andrea Z. Warmbier; Robin W. Edwards; Mark P. Dvorscak

(57) **ABSTRACT**

An amorphous robot includes a compartmented bladder containing fluid, a valve assembly, and an outer layer encapsulating the bladder and valve assembly. The valve assembly draws fluid from a compartment(s) and discharges the drawn fluid into a designated compartment to displace the designated compartment with respect to the surface. Another embodiment includes elements each having a variable property, an outer layer that encapsulates the elements, and a control unit. The control unit energizes a designated element to change its variable property, thereby moving the designated element. The elements may be electromagnetic spheres with a variable polarity or shape memory polymers with changing shape and/or size. Yet another embodiment includes an elongated flexible tube filled with ferrofluid, a moveable electromagnet, an actuator, and a control unit. The control unit energizes the electromagnet and moves the electromagnet via the actuator to magnetize the ferrofluid and lengthen the flexible tube.

20 Claims, 5 Drawing Sheets

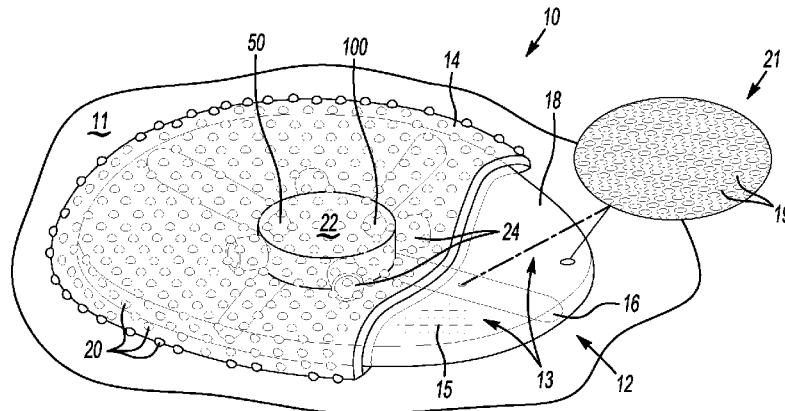

Related U.S. Application Data

of application No. 13/342,264, filed on Jan. 3, 2012, now Pat. No. 8,662,213.

(60) Provisional application No. 61/431,168, filed on Jan. 10, 2011.

(51) **Int. Cl.**

B62D 57/02 (2006.01)
B62D 57/00 (2006.01)
B64G 1/16 (2006.01)
G05D 1/02 (2006.01)

(56) **References Cited**

U.S. PATENT DOCUMENTS

6,137,891	A	10/2000	Porrazzo et al.	
6,484,083	B1 *	11/2002	Hayward	B60D 1/00 180/24.05
6,488,306	B1 *	12/2002	Shirey	B60D 1/00 280/474
6,523,629	B1 *	2/2003	Buttz	B60D 1/00 180/14.2
8,245,799	B2	8/2012	Chiel et al.	
8,316,970	B1	11/2012	Tran	
8,729,737	B2 *	5/2014	Schatz	H03H 7/40 307/104
9,545,611	B2 *	1/2017	Soucek	B01J 19/087
2004/0157082	A1 *	8/2004	Ritter	B82Y 25/00 428/611
2008/0058786	A1 *	3/2008	Boyden	A61B 5/0071 606/13
2008/0083571	A1	4/2008	Troy	
2008/0145428	A1	6/2008	Zheng	
2008/0164079	A1	7/2008	Jacobsen	

2008/0257615	A1	10/2008	Xie et al.	
2010/0094463	A1	4/2010	Okabayashi et al.	
2010/0135912	A1 *	6/2010	Gambhir	A61K 49/1896 424/9.32
2010/0145143	A1 *	6/2010	Salomon	B08B 9/049 600/104
2010/0150656	A1 *	6/2010	Feldman	E02B 3/06 405/111
2011/0131838	A1	6/2011	Pas et al.	
2011/0303016	A1 *	12/2011	Gutierrez	G01D 1/00 73/719
2012/0035434	A1 *	2/2012	Ferren	A61B 1/00156 600/301
2012/0035437	A1 *	2/2012	Ferren	A61B 1/041 600/302
2012/0046531	A1 *	2/2012	Hua	A61B 5/6865 600/317
2012/0175171	A1 *	7/2012	Bradley	B62D 57/00 180/7.1
2012/0256494	A1 *	10/2012	Kesler	H03H 7/40 307/104
2013/0172671	A1 *	7/2013	Rentschler	B32B 25/20 600/109
2013/0338433	A1 *	12/2013	Goldman	A61B 1/0052 600/102
2015/0230810	A1 *	8/2015	Creighton	A61B 17/22012 604/518
2017/0133891	A1 *	5/2017	Klassen	H02K 1/08

OTHER PUBLICATIONS

Zimmermann, K. et al., "Ferrofluid-based Flow Manipulation and Locomotion System," Journal of Intelligent Material Systems and Structures, Oct. 2010, pp. 1559-1562, vol. 21.

* cited by examiner

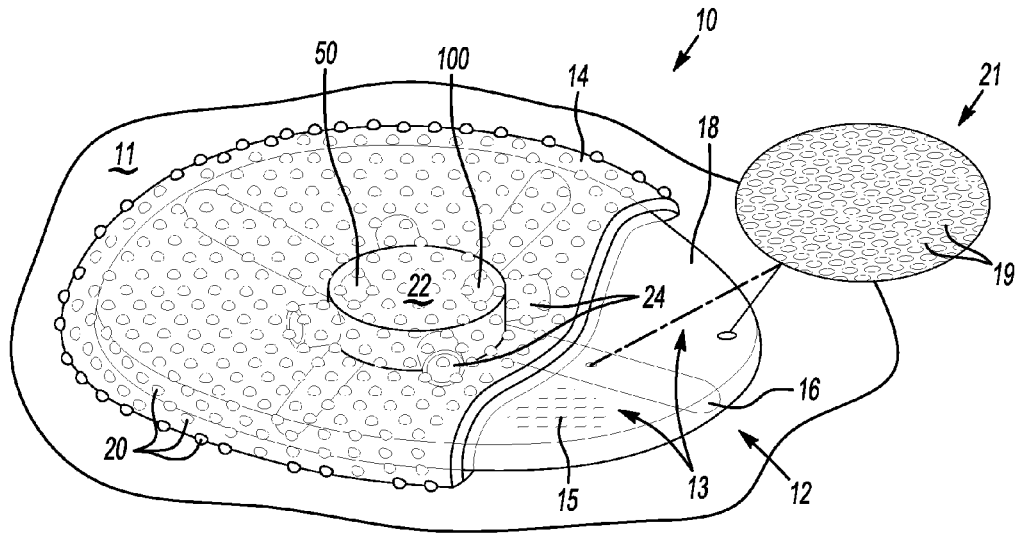

Fig-1

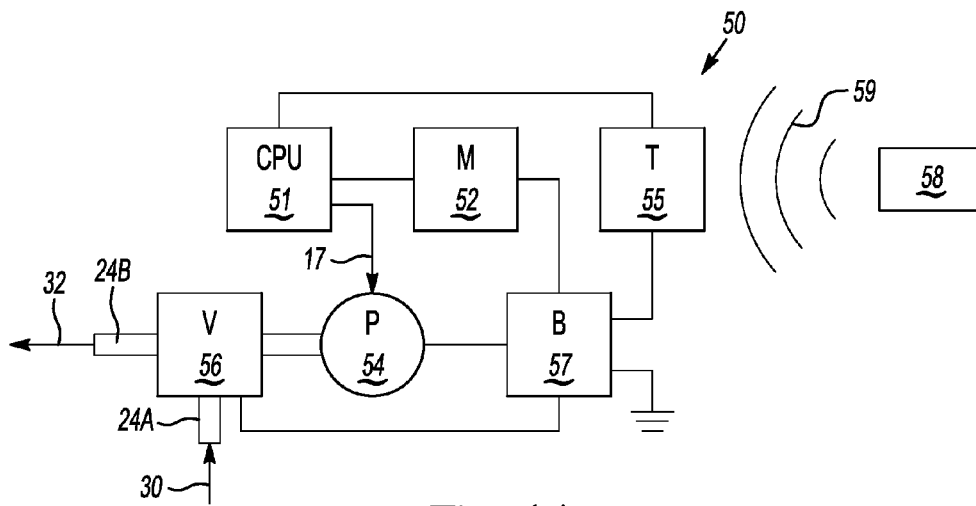
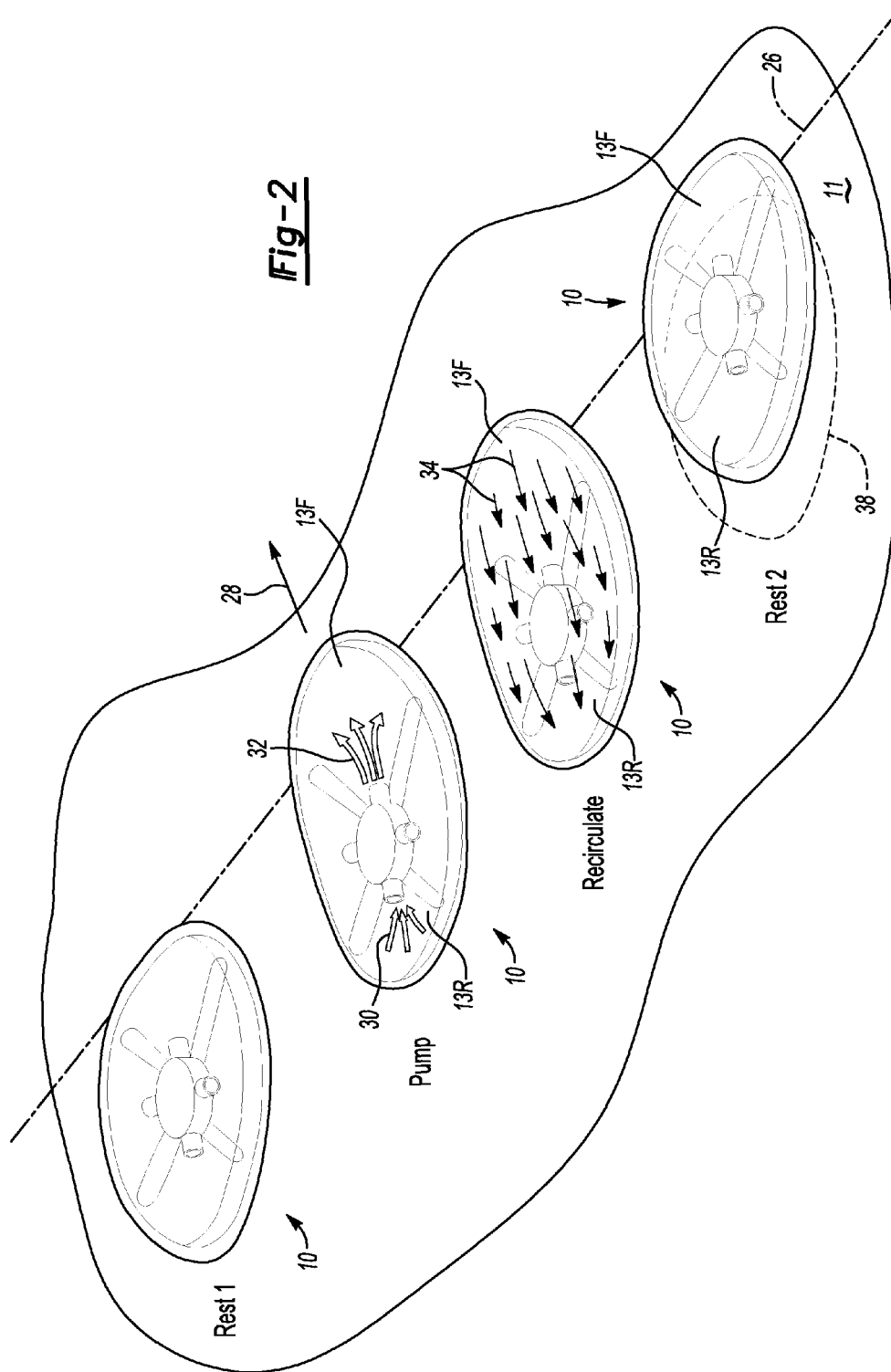

Fig-1A



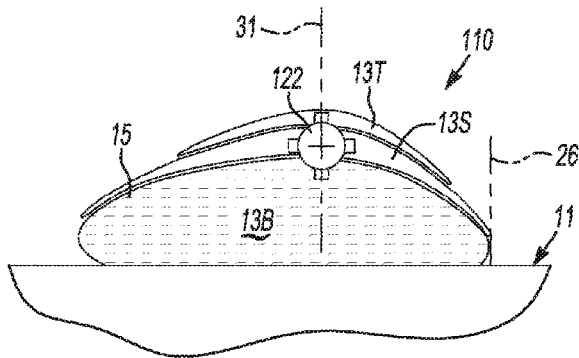

Fig-3A

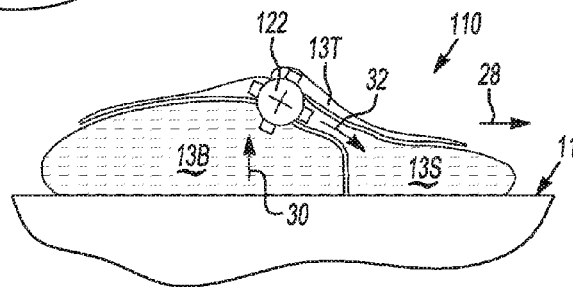

Fig-3B

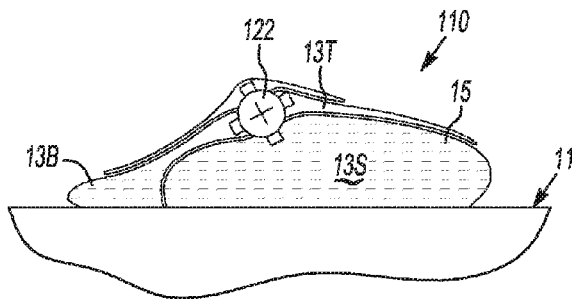

Fig-3C

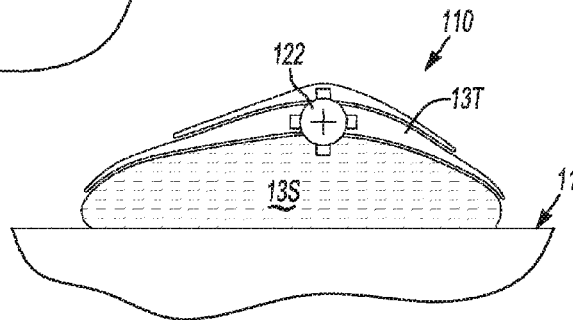

Fig-3D

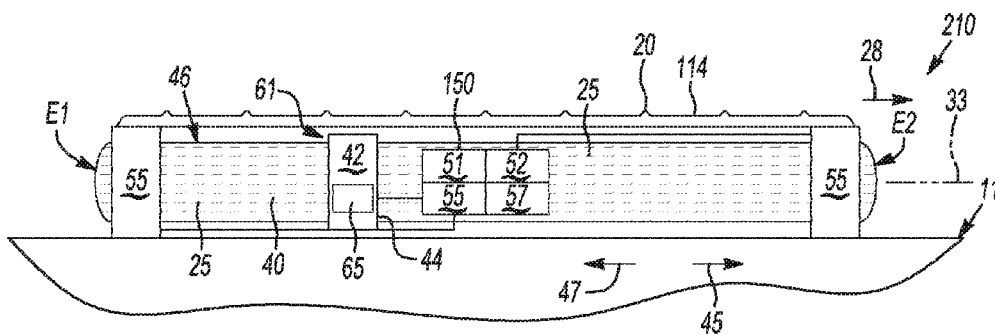

Fig-4

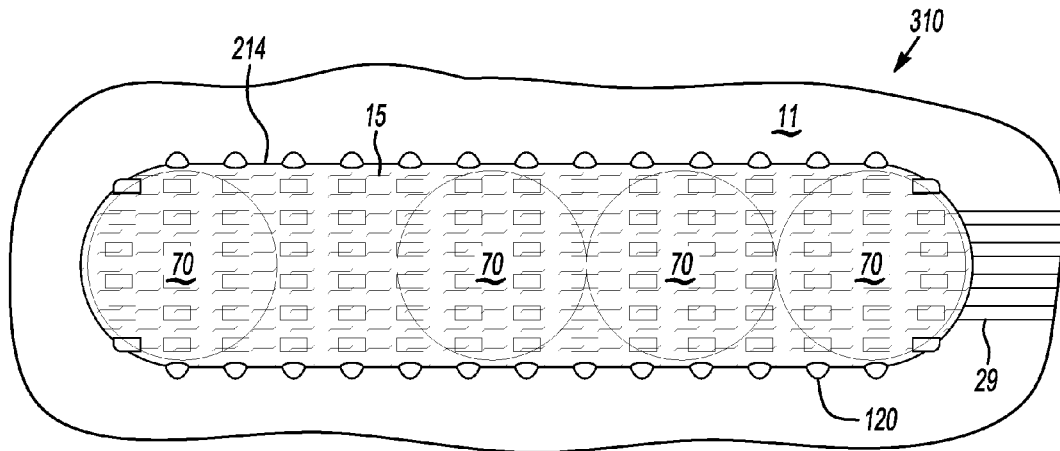

Fig-5

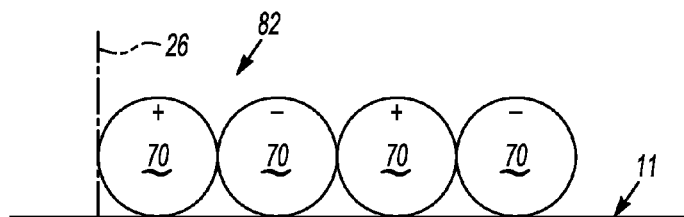

Fig-5A

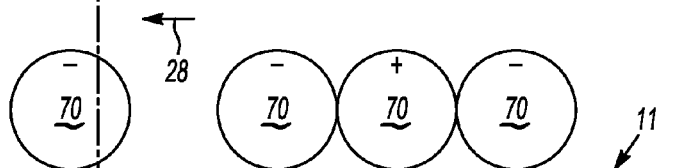

Fig-5B

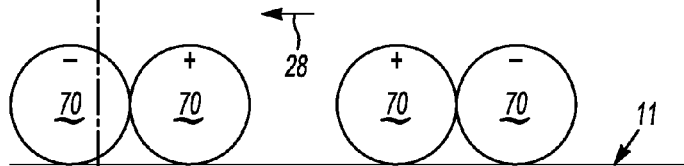

Fig-5C

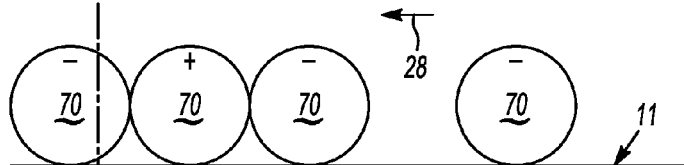

Fig-5D

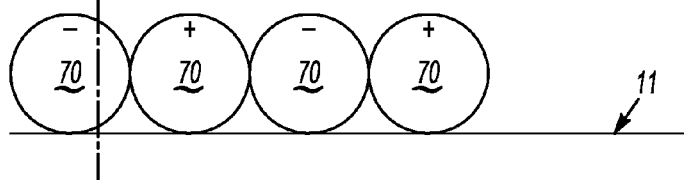

Fig-5E

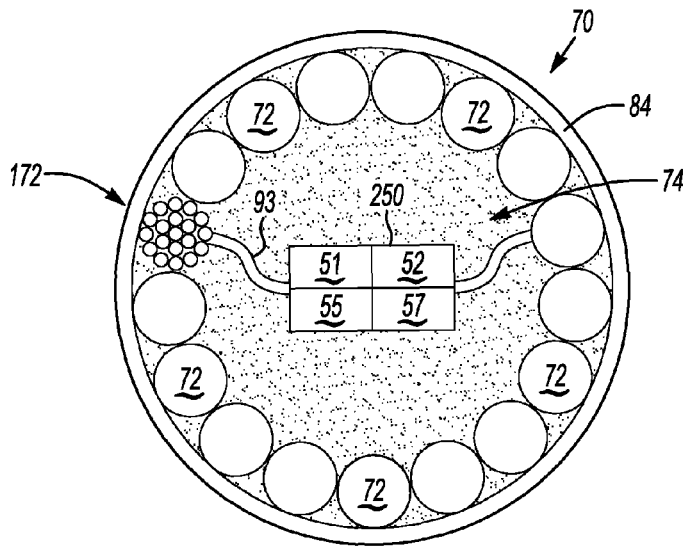

Fig-6

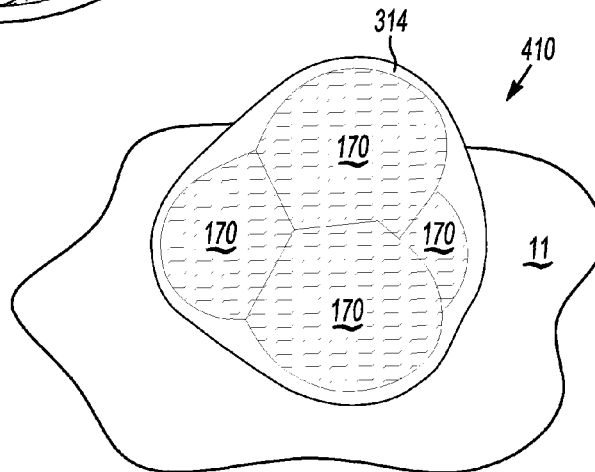

Fig-7

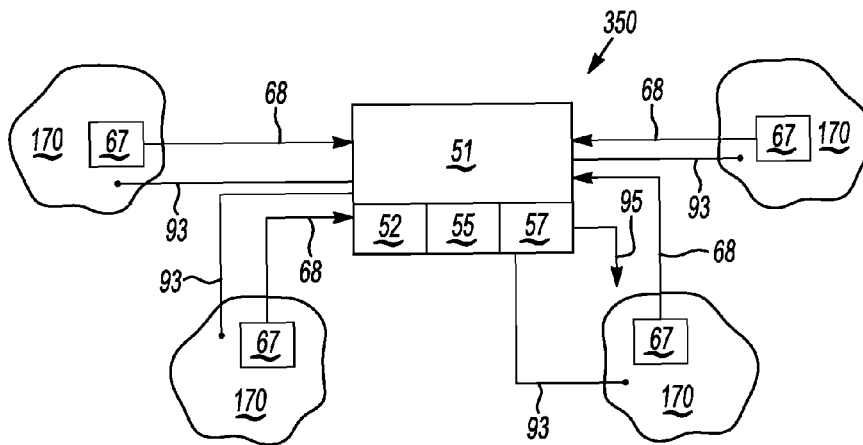

Fig-8

1

LOCOMOTION OF AMORPHOUS SURFACE ROBOTS

CROSS-REFERENCE TO RELATED APPLICATIONS

This patent application claims the benefit of priority to U.S. patent application Ser. No. 14/189,019, filed on Feb. 25, 2014, which claims the benefit of priority to U.S. patent application Ser. No. 13/342,264, filed Jan. 3, 2012, now U.S. Pat. No. 8,662,213, which claims the benefit of priority to U.S. Provisional Patent Application No. 61/431,168, filed on Jan. 10, 2011. Each of the foregoing applications is hereby incorporated by reference in its entirety.

STATEMENT REGARDING FEDERALLY SPONSORED RESEARCH OR DEVELOPMENT

The invention described herein was made by an employee of the United States Government, and may be manufactured and used by or for the Government for Government purposes without the payment of any royalties thereon or therefore.

TECHNICAL FIELD

The present disclosure relates to the locomotion of amorphous robots.

BACKGROUND OF THE INVENTION

Robots are electromechanical devices that perform work tasks automatically or autonomously. Robots are used in a host of applications, many of which present unique design challenges. For instance, complex surface-roving, robots generally referred to as “rovers” may be used in space exploration missions as well as in Earth-based search and rescue operations. Controlled via remote link, rovers can employ an array of sensors to collect and analyze soil samples, measure the atmospheric composition and weather conditions, and collect high-resolution imagery of the surface terrain over an extended period, often in relatively inhospitable operating environments. NASA’s Mars Pathfinder rover Sojourner and the more recent twin Mars Exploration rovers Spirit and Opportunity are examples of some space exploration rovers.

Once deployed on a surface, conventional rovers are typically propelled along a surface. In particularly sandy or loamy soil environments such as the lunar or Martian surfaces, conventional propulsion devices may become fouled and stuck. Rovers may therefore avoid exploring certain terrain features, or they may be programmed to follow a less than optimal route. Likewise, in some Earth-based roving applications, miniature rovers may be used to search through unstable piles of rubble or confined areas that are inaccessible to human search teams. Conventional rover designs may be less than optimal in these applications due to certain design limitation that may cause the rovers to become irretrievably stuck in the rubble or other difficult to navigate surface features.

SUMMARY OF THE INVENTION

An amorphous surface robot is disclosed herein. In its various embodiments, the amorphous robot provides improved surface mobility. As used herein, the term “amorphous robot” refers to a robot lacking a rigidly defined and

2

unchanging shape. The presently disclosed robots change shape in the direction of intended travel to provide improved surface mobility along with enhanced protection from the elements.

5 The presently disclosed amorphous robot designs rely on one or more of the following principles: (1) the circulation of fluid in the desired direction of travel via a fully enclosed valve assembly; (2) the sequential switching of polarity of one or more fully enclosed electromagnets; and/or (3) the sequential expansion and deflation of an active material-based polymeric sac or cell. All disclosed robot designs enable movement with respect to a solid surface, as opposed to movement through free space or a liquid operating environment, without the use of wheels, tracks, or legs. All designs are fully scalable, and thus can be readily adapted as needed to the particular application and operating environment in which the robots are to be used.

In particular, an amorphous robot for use on a surface includes a supply of fluid, a bladder, a valve assembly, and a flexible outer layer. The bladder contains the supply of fluid and is divided into compartments. The valve assembly is in fluid communication with each of the compartments and includes a pump. The outer layer encapsulates the bladder and the valve assembly. The valve assembly selectively draws some of the fluid from at least one of the compartments and discharges the drawn fluid into a designated one of the compartments to displace the designated compartment with respect to the surface. This moves the amorphous robot in the direction of the discharge.

Another amorphous robot includes a plurality of elements each having a variable property, a flexible outer layer that encapsulates the plurality of elements, and a control unit in electrical communication with the elements. The control unit selectively energizes a designated one of the elements to change the variable property of that element, thereby moving the designated element with respect to the remaining elements. The robot thus moves with respect to the surface in the direction of movement of the designated element.

The elements in one embodiment are electromagnetic spheres, and the variable property is the magnetic polarity of the electromagnetic spheres. Alternatively, the elements may be polymer cells such as shape memory polymer (SMP) cells. In such an embodiment, the variable property may be a variable shape and/or size of the SMP cells.

Yet another embodiment of the present amorphous robot includes an elongated flexible tube filled with ferrofluid and having a longitudinal axis, a moveable electromagnet positioned with respect to the elongated flexible tube, an actuator, and a control unit. The actuator is connected to the electromagnet and selectively moves the electromagnet. The control unit is electrically connected to the moveable electromagnet and to the actuator. The control unit energizes the electromagnet and moves, via the actuator, the electromagnet in a first direction with respect to the longitudinal axis. This magnetizes the ferrofluid and thereby lengthens the flexible tube in the first direction. The control unit then de-energizes the electromagnet to thereby de-magnetize the ferrofluid and thus shorten the flexible tube in the first direction. This moves the robot in the first direction with respect to the surface, in a manner similar to that of a worm which extends in a desired direction, grips the surface, and then pulls its trailing portion forward.

The above features and advantages and other features and advantages of the present invention are readily apparent from the following detailed description of the best modes for carrying out the invention when taken in connection with the accompanying drawings.

BRIEF DESCRIPTION OF THE DRAWINGS

FIG. 1 is a schematic partial cut-away perspective top view illustration of an example amorphous robot having a fluid-filled compartmentalized bladder and an enclosed valve assembly.

FIG. 1A is a schematic illustration of an example control unit for use with the amorphous robot shown in FIG. 1.

FIG. 2 is a schematic illustration of an example movement sequence of the amorphous robot shown in FIG. 1.

FIG. 3A is a schematic side view illustration of an alternative embodiment of the amorphous robot of FIG. 1 having a vertically-oriented valve assembly, with the robot shown in a resting state.

FIG. 3B is a schematic side view illustration of the amorphous robot of FIG. 3A in a partially filled motion state.

FIG. 3C is a schematic side view illustration of the amorphous robot of FIGS. 3A and 3B in a settling state.

FIG. 3D is a schematic side view illustration of the amorphous robot of FIGS. 3A-C in another resting state.

FIG. 4 is a schematic top view illustration of another amorphous robot that uses ferrofluid and a moveable electromagnet for propulsion.

FIG. 5 is a schematic top view illustration of yet another amorphous robot that uses a series of sequentially-activated electromagnets for propulsion.

FIG. 5A is a schematic side view illustration of a portion of the robot of FIG. 5 in a resting state.

FIG. 5B is a schematic side view illustration of the robot of FIG. 5A in a first stage of motion.

FIG. 5C is a schematic side view illustration of the robot of FIGS. 5A and 5B in a second stage of motion.

FIG. 5D is a schematic side view illustration of the robot of FIGS. 5A-C in a third stage of motion.

FIG. 5E is a schematic side view illustration of the robot of FIGS. 5A-D in another resting state.

FIG. 6 is a schematic cross-sectional side view of an example electromagnet usable with the amorphous robot of FIGS. 5-5E.

FIG. 7 is a schematic perspective side view illustration of an amorphous robot having a plurality of polymeric cells.

FIG. 8 is a schematic illustration of an example control unit usable with the amorphous robot shown in FIG. 7.

DETAILED DESCRIPTION OF THE INVENTION

Referring to the drawings, wherein like reference numbers correspond to like or similar components throughout the several figures, an amorphous robot 10 is shown in FIG. 1. The robot 10 is positioned with respect to a surface 11, for instance a terrestrial surface or a lunar, Martian, or other extraterrestrial surface. The robot 10 includes a valve assembly 22 and a bladder 12, the latter defining a plurality of compartments 13. An outer layer 14 fully encapsulates the bladder 12 such that the bladder 12 is completely shielded and thus isolated from dirt or debris of the surface 11 and the surrounding atmosphere. A portion of the outer layer 14 is removed in FIG. 1 to more clearly illustrate the structure of the bladder 12 encapsulated by the outer layer 14.

The outer layer 14 may include surface asperities 20 which form pseudopodia (false feet). Asperities 20 may be, by way of example, surface features such as nodules, fingers, or bumps. The asperities 20 extend from the robot 10 to grip the surface 11 and thus facilitate movement of the robot 10. As temperatures can vary widely on a given surface 11, all

materials of construction should be selected to properly match the conditions of the intended operating environment.

The robot 10 may include a control unit 50, an example of which is described in greater detail below with reference to FIG. 1A. The control unit 50 may be enclosed within the valve assembly 22 and/or electrically connected thereto. A sensor 100 may be attached to the robot 10. Such a sensor 100 may draw power from the control unit 50. The valve assembly 22 may also include a plurality of fluid ports 24. Each fluid port 24 may be positioned within a respective one of the compartments 13. That is, the number of ports 24 may equal the number of compartments 13 in one embodiment. Control of the valve assembly 22 for movement of the robot 10 with respect to the surface 11 is described below with reference to FIG. 2.

Each of the various compartments 13 may contain a variable amount of fluid 15. Four compartments 13 are shown in the non-limiting example embodiment of FIG. 1. More or fewer compartments 13 may be provided in other designs, with at least two compartments 13 required for basic front-to-back or side-to-side motion. Regardless of the number of compartments 13, the valve assembly 22 is in fluid communication with each of the compartments 13. The valve assembly 22 ultimately controls the flow of fluid 15 between the different compartments 13 so as to move the robot 10 in a desired direction. The ports 24 are shown schematically in FIG. 1 for simplicity. Those of ordinary skill in the art will recognize that the actual ports 24 would have a length, shape, and orientation within the compartments 13 sufficient for ensuring that each compartment 13 can be substantially vacated or filled with fluid 15 as needed.

Each compartment 13 of the robot 10 may be separated from adjacent compartments 13 by a compartment wall 16, for instance a fluid-permeable wall in the form of a membrane or mesh, or an impermeable/solid wall. Surfaces 18 of the bladder 12, including or excluding the compartment wall 16 depending on the embodiment, may be configured to allow the fluid 15 to gradually flow at a closely controlled rate from one compartment 13 to another. As shown in the inset 21, the surfaces 18 may be a membrane, mesh, or other porous and/or fluid-permeable material defining pores 19. The pores 19 may be of a calibrated size and/or number so as to gently and gradually equalize fluid pressure in the various compartments 13 after completing a fill of a designated compartment 13, as will be explained below with reference to FIG. 2.

Referring to FIG. 1A, in one possible example the control unit 50 of FIG. 1 may include a microprocessor or CPU 51, memory (MEM) 52, a fluid pump (P) 54, a transceiver unit (T) 55, a valve body (VB) 56, and a battery (B) 57. The control unit 50 may be at least partially constructed in some embodiments as a micro-electromechanical system (MEMS), as is understood in the art. The pump 54 is electrically connected to the battery 57, for instance a lithium ion, nickel cadmium, or other single or multi-cell rechargeable battery or any other suitable power supply. The battery 57 may be recharged using solar power in some embodiments, e.g., using a solar panel (not shown). Such a design may help to extend the operating life of the robot 10 of FIG. 1, and may be advantageous for reducing the weight/size of battery 57.

The pump 54 may be energized via the battery 57 in response to a command signal (arrow 17) from the CPU 51. When energized, the pump 54 draws fluid 15 (see FIG. 1) from one compartment 13 through an inlet fluid port 24A as indicated by inlet arrow 30. The pump 54 may then circulate the fluid 15 through the valve body 56 before discharging the

5

fluid 15 through an outlet fluid port 24B to another compartment 13 as indicated by outlet arrow 32.

The transceiver 55 of FIG. 1A, which may be used in all embodiments disclosed herein, may receive a set of control signals 59 from a source 58. The control signals 59 may be, by way of example, a set of mission control signals broadcast from a ground-based or an orbiting control platform. Thus, the source 58 may be an orbiting module in remote downlink/uplink wireless communication with the robot 10, or the source 58 may be a conventional rover from which the robot 10 is deployed.

For instance, a conventional rover may carry the robot 10 to a difficult to navigate terrain feature such as a rock-strewn crater, deploy the robot 10, and communicate with the robot 10 as the robot 10 moves into the crater and performs a work task. The robot 10 may periodically establish a communications link with the source 58, download program instructions for a particular task sequence to memory 52, execute the instructions via the CPU 51, and repeat the process as needed. Alternatively, all required instructions may be pre-loaded in memory 52 to provide greater autonomy of action by the robot 10 and/or to conserve the battery 57.

Referring to FIG. 2, locomotion of the amorphous robot 10 of FIG. 1 with respect to surface 11 is explained with respect to a reference line 26 on the surface 11. When at position "Rest 1" the robot 10 is adjacent to the reference line 26. The valve assembly 22 of FIG. 1 is inactive, and fluid 15 shown in the same Figure is about equally distributed within the various compartments 13. The pumping stage (Pump) shown in FIG. 2 is entered when motion is desired. As shown in FIG. 1A, the command signal (arrow 17) is transmitted to the pump 54. In response, the fluid 15 of FIG. 1 is drawn into the valve assembly 22 from a rear compartment 13R as indicated by inlet arrows 30. This fluid 15 is then discharged into a forward compartment 13F as indicated by outlet arrows 32, with the term "forward" here used to mean "opposite the rear compartment 13R", and thus the actual compartment 13F could be a side or rear compartment in an absolute sense. In other words, the actual direction of motion will vary with the particular compartment 13 being filled. As a result of filling the forward stage 13F, the mass of the robot 10 is displaced across the reference line 26 in the direction of arrow 28.

At the recirculation phase (Recirculate), fluid 15 discharged into the forward compartment 13F gradually returns to the other compartments 13, 13R as indicated by flow return arrows 34. This equalizing return flow occurs by virtue of the pores 19 of the material 18 as shown in FIG. 1. The diameter, number, and spacing of the various pores 19 may be selected to provide the desired rate of equalization as noted above. Alternatively, the valve assembly 22 of FIG. 1 may be configured to allow fluid 15 to slowly flow back through itself to the various compartments 13 at a controlled rate. While pressure equalization is progressing, the asperities 20 of FIG. 1 continue to grip the surface 11 and thereby hold the robot 10 in place. The robot 10 of FIG. 2 then settles at a new rest position (Rest 2) forward of the original reference line 26. The original rest position (Rest 1) is indicated by trace 38. The above process can be repeated from the new rest position (Rest 2).

Referring to FIGS. 3A-D, the amorphous robot 10 of FIG. 1 may be alternatively configured as an amorphous robot 110 having a vertically-oriented valve assembly 122. That is, unlike the valve assembly 22 of FIG. 1 in which the axes of the various fluid ports 24 are substantially parallel to the surface 11, two of the fluid ports 24 of the valve assembly 122 of FIGS. 3A-D have a common axis 31 that is substan-

6

tially perpendicular to the plane of the surface 11 when the robot 110 is at rest on a flat surface as shown in FIG. 3A. The term "substantially perpendicular" in one embodiment refers to a range of about 85° to about 95° with respect to the plane of the surface 11. The robot 110 of FIGS. 3A-D operates in much the same manner as the robot 10, but with a resultant rotational/tumbling action.

The robot 110 is shown in FIG. 3A as it appears relative to the reference line 26. A top compartment 13T is positioned above the valve assembly 122, a bottom compartment 13B is positioned below the valve assembly 122, i.e., closer to the surface 11 than the top compartment 13T, and side compartments 13S are positioned on either side of the valve assembly 122. Fluid 15 is contained within the bottom compartment 13B, and at negligible levels in the respective side and top compartments 13S and 13T. Thus, FIG. 3A represents an equilibrium starting condition.

In FIG. 3B, fluid 15 is drawn into the valve assembly 122 from the bottom compartment 13B as indicated by inlet arrow 30. The fluid 15 is then discharged into a desired side compartment 13S as indicated by outlet arrow 32. Fluid flow into side compartment 13S fills the side compartment 13S and empties the bottom compartment 13B. This causes the robot 110 to surge forward a bit with respect to the surface 11 as indicated by arrow 28. In FIG. 3C, with the desired one of the compartments 13S now substantially filled with fluid 15, the robot 110 begins to settle. The pumping action ceases. FIG. 3D represents the new starting position, with the robot 110 at rest a bit forward of its starting position represented in FIG. 3A. The process resumes with FIG. 3A, with compartment 13S of FIG. 3D now becoming the bottom compartment 13B of FIG. 3A.

Referring to FIG. 4, in yet another embodiment an amorphous robot 210 may include an elongated flexible inner tube 40 disposed within a flexible outer layer 114. The outer layer 114 may be similar to the outer layer 14 shown in FIG. 1, e.g., with similar materials and asperities 20 which grip the surface 11. The flexible tube 40, which has first and second closed ends E1 and E2, respectively, is filled with ferrofluid 25 and is circumscribed by a moveable electromagnet 42, for instance a ring. A gap (arrow 61) is defined between the inner tube 40 and the outer layer 114. Optionally, the gap (arrow 61) can be pre-pressurized with fluid or an inert gas to help maintain a calibrated space or standoff with respect to the electromagnet 42. This may facilitate axial movement of the electromagnet 42.

In a particular embodiment, lightweight end magnets 55 may be positioned at or toward either end of the inner tube 40, with the inner tube 40 and the outer layer 114 being affixed to both of the end magnets 55. The end magnets 55 can act as mechanical stops to extreme motion of the electromagnet 42 if needed, and can also provide an electromagnetic field whose polarity may be changed as needed by a control unit 150 to thereby create a magnetic field for assisting in the push-pull motion of the electromagnet 42, as will be understood by one of ordinary skill in the art.

The electromagnet 42 and the end magnets 55 of FIG. 4 may be electrically connected to the control unit 150 and positioned such that an inner surface 44 of the electromagnet 42 is positioned adjacent to an outer surface 46 of the inner tube 40. The control unit 150 may include sufficient memory 52 and a processor/CPU 51, along with a battery 57 and a transceiver 55 as explained above with reference to the control unit 50 of FIG. 1A. The control unit 150 may selectively move the electromagnet 42 via an actuator 65 as shown schematically in FIG. 4. As the outer layer 114 helps insulate and encapsulate the electromagnet 42, rotating or

linearly translating parts may be employed as the actuator **65** without much concern for premature fouling of the actuator **65** by surface contaminants. Thus, one of ordinary skill in the art may envision various possible embodiments for the actuator **65**, including but not limited to a motor, a motorized ball screw, a linear actuator, cables, and/or smart materials such as a shape memory alloy (SMA) wire.

The ferrofluid **25** filling the inner tube **40** of FIG. **4** may be any liquid which becomes strongly magnetized in the presence of an applied magnetic field. As is well understood by those of ordinary skill in the art, a ferrofluid typically contains a Brownian suspension of nanoscale ferromagnetic or ferrimagnetic particles in an organic solvent. Non-limiting example particles include magnetite and hematite. When magnetized by the electromagnet **42**, the suspended particles align in the direction of magnetic flux and thus form a generally rigid clump at one end of the inner tube **40**. That is, controlled movement of the energized electromagnet **42** in the direction of arrow **45** along the axis **33** of the tube **40** magnetizes the ferrofluid **25** and forces it toward one end of the tube **40**, thus slightly lengthening the tube **40** in the direction of arrow **28**.

Deactivation of the electromagnet **42** and return in the direction of arrow **47** to its starting position, with assistance of the actuator and any required field coordination with the end magnets **55**, thus allows the robot **210** to gradually inch its way along the surface **11**. Direction of motion may be changed via changing the polarity as needed of the various the end magnets **55** and the electromagnet **42**. However, unlike the previous designs motion of the robot **210** if FIG. **4** is directionally limited to the axis **33**. As will all of the present embodiments, the tube **40** may be connected to a sensor and deployed from a rover or other vehicle, or used separately from such a rover depending on the intended application. The motion of the robot **210** may be remotely controlled as explained above with reference to FIG. **1A**.

Referring to FIG. **5**, the polarity-changing locomotive approach of FIG. **4** may be applied to another amorphous robot **310**. A plurality of elements **70** in the form of electromagnetic spheres are fully encapsulated within a flexible outer layer **214**. The elements **70**, referred to hereinafter as electromagnetic spheres **70** for clarity, have a variable property in the form of a variable magnetic polarity. The polarity of the electromagnetic spheres **70** may be sequentially changed to thereby move the robot **310** in a desired direction with respect to the surface **11**.

As with the embodiments of FIGS. **1-4**, asperities **120** may be provided on the outer layer **214** to help grip the surface **11**, as indicated by the set of tracks **29** left in the soil of the surface **11**. Fluid **15** may act as a damping fluid by filling the void between the electromagnets **70** and the outer layer **214**. This may help in protecting the electromagnetic spheres **70** and damping the force of any collision adjacent electromagnetic spheres **70**.

Referring to FIG. **5A**, at rest with respect to the reference line **26**, every other electromagnetic sphere **70** has the same polarity, e.g., an initial polarity sequence of (+, -, +, -) as shown. This alternating sequence acts to magnetically bind the electromagnetic spheres **70** to each other in a series, i.e., in line. As shown in FIG. **5A**, the lead electromagnetic sphere **70**, which is identified in FIG. **5A** by arrow **82**, is repelled in the direction of arrow **28** by changing its polarity such that the polarity matches that of the next electromagnet **70**, here represented as a change from positive (+) to negative (-) polarity.

Likewise, changing the polarity sequence to (-, +, +, -) as shown in FIG. **5C** magnetically repels the second electro-

magnetic spheres **70** away from the third electromagnetic spheres **70** in the sequence and toward the lead electromagnetic sphere **70**. The process continues as shown in FIGS. **5D** and **5E**, with FIG. **5E** representing the new starting position a bit forward of the reference line **26**.

Referring to FIG. **6**, each electromagnetic sphere **70** may include a control unit **250** that selectively energizes a designated one of the electromagnetic spheres **70** to change the polarity of the designated electromagnetic sphere **70**, thereby moving the designated electromagnetic sphere **70** with respect to the remaining spheres **70**. The amorphous robot **310** thus moves with respect to the surface **11** in the direction of movement of the designated electromagnetic sphere **70**.

The control unit **250** may include memory **52**, a transceiver **55**, and a battery **57**. A microprocessor/CPU **51** may be included within at least one of the electromagnetic spheres **70** to provide top-level sequential control of the robot **310**. The control unit **250** may be fully encapsulated by a magnetically neutral outer layer or shell **84**. The shell **84** may define a core **74** of a suitable dielectric and thermal insulating material.

Conductive coils **72** may be wrapped with respect to the core **74**. Coils **72** may be bundles of smaller wires as indicated by arrow **172**. The internal detail is shown for only one coil **72** in FIG. **6** for illustrative simplicity. The coils **72** are electrically connected to the battery **57** of the control unit **250** by conductive leads **93**. Changing the direction of flow of an electrical current through the coils **72**, which can be selectively performed by the control unit **250** as understood in the art, thus changes the polarity of a given electromagnetic sphere **70** as needed, as will be appreciated by one of ordinary skill in the art. Controlled sequential polarity change is therefore used to provide the motion sequence shown in FIGS. **5A-E** as described above.

Referring to FIG. **7**, in yet another embodiment an amorphous robot **410** may include a plurality of elements **170** in the form of polymeric cells, which hereinafter are referred to as cells **170** for clarity. The cells **170** are collectively encapsulated within a flexible outer layer **314**. The outer layer **314** may be similar to the designs set forth above with reference to FIGS. **1-6** for outer layers **14**, **114**, and **214**. The individual cells **170** may be formed from a shape-memory polymer (SMP) or other suitable shape-changing material. As is well understood in the art, SMPs are a polymeric class of smart materials that can return from a temporary deformed state to a permanent default shape when stimulated by an external stimulus. SMPs can thus maintain their temporary shape until a shape change back into the permanent form is activated by an applied stimulus, or by the termination of an applied stimulus depending on the embodiment.

By selectively changing the shape of a designated one of the cells **170**, the robot **410** of FIG. **7** can be caused to rotate and thus tumble in a desired direction. The number and size/shapes of the cells **170** may vary with the design to provide the desired mobility. The cells **170** may be stimulated via heat and/or electricity or light depending on the embodiment. Therefore, the robot **410** may include a battery **57** as part of a control unit **350** as will now be described with reference to FIG. **8**.

The control unit **350** of FIG. **8** is electrically connected to each of the cells **170** via a conductor **93**, e.g., a length of wire or a coil. The control unit **350** may be disposed within one of the cells **170**, wedged between the various cells **170**, or otherwise enclosed by the outer layer **314**. The control unit

350 may include a microprocessor or CPU 51, memory 52, a transceiver 55, and the battery 57.

As with the embodiment shown in FIG. 1A, which applies to all embodiments disclosed herein, a source 58 may transmit signals 59 to the robot 410 of FIG. 7, with the signals 59 received by the transceiver 55. The CPU 51 may then execute mission instructions communicated via the signals 59, or may download the same to memory 52 for later execution. Thus, when the robot 410 of FIG. 7 is to move in a desired direction, the CPU 51 can stimulate one of the cells 170 via transmission of a stimulus signal (arrow 95), as shown in FIG. 8. The shape of the cell 170 changes, e.g., increases in size, such that the robot 410 tumbles in a desired direction.

Because the gravitational pull toward surface 11 of FIG. 7 provides the motive force, a sensor pack 67 may be provided, e.g., in each polymer cell 170, to identify the position and orientation of cell 170. Sensor pack 67 may include a gyroscope, accelerometer, and/or any other sensor capable of determining, individually or collectively, the position of one cell 170 relative to the surface 11 and the other cells 170, and communicating the same as a position signal (arrow 68) to the control unit 350. Thus, the control unit 350 can determine the cell 170 having the optimal position for activation.

The cell 170 identified as being the best candidate cell for activation may be increased in size and/or changed in shape such that the cell 170 with the temporarily increased shape will fall toward the surface 11 and cause the robot 410 to topple. The cells 170 can be connected to each other such that movement of one cell pulls the other cells 170 in a particular direction, or the cells 170 can be different portions or regions of a single cell 170. In the latter embodiment, conductors 93 may be implanted in the different regions of the single cell 170 to provide the required response.

While the best modes for carrying out the invention have been described in detail, those familiar with the art to which this invention relates will recognize various alternative designs and embodiments for practicing the invention within the scope of the appended claims.

What is claimed is:

1. An amorphous robot for use on a surface, the amorphous robot comprising:

an elongated flexible tube having closed first and second ends, wherein the elongated flexible tube is filled with ferrofluid and has a longitudinal axis;

a moveable electromagnet positioned with respect to the elongated flexible tube;

an actuator that is connected to the electromagnet and that selectively moves the electromagnet; and

a control unit that is electrically connected to the moveable electromagnet and to the actuator;

wherein the control unit alternatively:

energizes the electromagnet and moves the electromagnet, via the actuator, in a first direction with respect to the longitudinal axis to thereby magnetize the ferrofluid to create a rigid clump of magnetized particles of the ferrofluid at one of the closed ends of the inner tube and thereby lengthen the flexible tube in the first direction; and

de-energizes the electromagnet to thereby de-magnetize the ferrofluid and shorten the flexible tube in the first direction, thus moving the robot in the first direction with respect to the surface.

2. The amorphous robot of claim 1, wherein the electromagnet is annular and circumscribes an outer surface of the elongated flexible tube.

3. The amorphous robot of claim 2, further comprising a flexible outer layer which encapsulates the electromagnet and the elongated flexible tube, wherein:

a gap is defined between the elongated flexible tube and the flexible outer layer; and

the electromagnet moves through the gap.

4. The amorphous robot of claim 3, further comprising a pair of end magnets positioned at either end of the elongated flexible tube, wherein the control unit selectively activates at least one of the end magnets to thereby assist in the movement of the electromagnet through the gap.

5. The amorphous robot of claim 2, wherein the control unit includes a transceiver in communication with a remote source, and wherein the transceiver receives a set of control signals broadcast by the remote source.

6. The amorphous robot of claim 1, wherein the ferrofluid comprises a Brownian suspension of nanoscale ferromagnetic or ferrimagnetic particles in an organic solvent.

7. The amorphous robot of claim 6, wherein the ferromagnetic particles comprise magnetite or hematite.

8. The amorphous robot of claim 1, wherein the actuator comprises a motor, a motorized ball screw, a linear actuator, cables, or smart material.

9. The amorphous robot of claim 8, wherein the smart material comprises a shape memory alloy (SMA) wire.

10. The amorphous robot of claim 1, wherein the actuator consists of a shape memory alloy material.

11. An amorphous robot for use on a surface, the amorphous robot comprising:

an elongated flexible tube filled with ferrofluid and having a longitudinal axis, and having closed first and second ends such that the ferrofluid is contained within the elongated flexible tube;

a moveable electromagnet positioned with respect to the elongated flexible tube;

a flexible outer layer which encapsulates the electromagnet and the elongated flexible tube, wherein a gap is defined between the elongated flexible tube and the flexible outer layer; and the electromagnet moves through the gap;

an actuator that is connected to the electromagnet and that selectively moves the electromagnet; and

a control unit that is electrically connected to the moveable electromagnet and to the actuator;

wherein the control unit alternatively:

energizes the electromagnet and moves the electromagnet, via the actuator, in a first direction with respect to the longitudinal axis to thereby magnetize the ferrofluid to thereby create a rigid clump of magnetized particles of the ferrofluid at one of the closed ends of the inner tube, and to thereby lengthen the flexible tube in the first direction; and

de-energizes the electromagnet to thereby de-magnetize the ferrofluid and shorten the flexible tube in the first direction, thus moving the robot in the first direction with respect to the surface.

12. The amorphous robot of claim 11, wherein:

a gap is defined between the elongated flexible tube and the flexible outer layer; and

the electromagnet moves through the gap.

13. The amorphous robot of claim 12, wherein the control unit includes a transceiver in communication with a remote source, and wherein the transceiver receives a set of control signals broadcast by the remote source.

14. The amorphous robot of claim 13, wherein the actuator comprises a motor, a motorized ball screw, a linear actuator, cables, or smart material.

11

15. The amorphous robot of claim **14**, wherein the smart material comprises a shape memory alloy (SMA) wire.

16. The amorphous robot of claim **13**, wherein the actuator consists of a shape memory alloy material.

17. An amorphous robot for use on a surface, the amorphous robot comprising:

an elongated flexible tube filled with ferrofluid and having a longitudinal axis, the elongated flexible tube having closed first and second ends;

a moveable electromagnet positioned with respect to the elongated flexible tube;

a flexible outer layer which encapsulates the electromagnet and the elongated flexible tube;

an actuator that is connected to the electromagnet and that selectively moves the electromagnet; and

a control unit that is electrically connected to the moveable electromagnet and to the actuator, wherein the control unit comprises a transceiver in communication with a remote source, and wherein the transceiver receives a set of control signals broadcast by the remote source;

wherein the control unit alternatively:

12

energizes the electromagnet and moves the electromagnet, via the actuator, in a first direction with respect to the longitudinal axis to thereby magnetize the ferrofluid to thereby create a rigid clump of magnetized particles of the ferrofluid at one of the closed ends of the inner tube, and to thereby lengthen the flexible tube in the first direction; and

de-energizes the electromagnet to thereby de-magnetize the ferrofluid and shorten the flexible tube in the first direction, thus moving the robot in the first direction with respect to the surface.

18. The amorphous robot of claim **17**, further comprising a pair of end magnets positioned at either end of the elongated flexible tube, wherein the control unit selectively activates at least one of the end magnets to thereby assist in the movement of the electromagnet through the gap.

19. The amorphous robot of claim **17**, wherein the actuator comprises a motor, a motorized ball screw, a linear actuator, cables, or smart material.

20. The amorphous robot of claim **19**, wherein the smart material comprises a shape memory alloy (SMA) wire.

* * * * *