

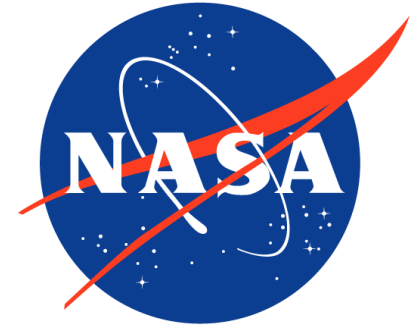

MAY 15-17, 2018 | Linthicum (Baltimore), MD

**IPC HIGH RELIABILITY FORUM FOR MIL-AERO AND AUTOMOTIVE SECTORS**

*Technical Conference with a focus on Electronics Subjected to Harsh Use Environments*



# Achieving Improved Reliability with Failure Analysis

## Bhanu Sood

Reliability and Risk Assessment Branch  
NASA Goddard Space Flight Center  
[bhanu.sood@nasa.gov](mailto:bhanu.sood@nasa.gov)

# Disclaimer

The material herein is presented “for guidance only”. We do not warrant the accuracy of the information set out on this presentation. It may contain technical inaccuracies or errors and/or non-updated data.

Information may be changed or updated without notice.

# PDC Outline

**Section 1: What is reliability and root cause?**

**Section 2: Overview of failure mechanisms**

**Section 3: Failure analysis techniques**

- Non-destructive analysis techniques
- Destructive analysis
- Materials characterization

**Section 4: Summary and closure**

**Discussions and case studies of actual failures and subsequent analysis.**

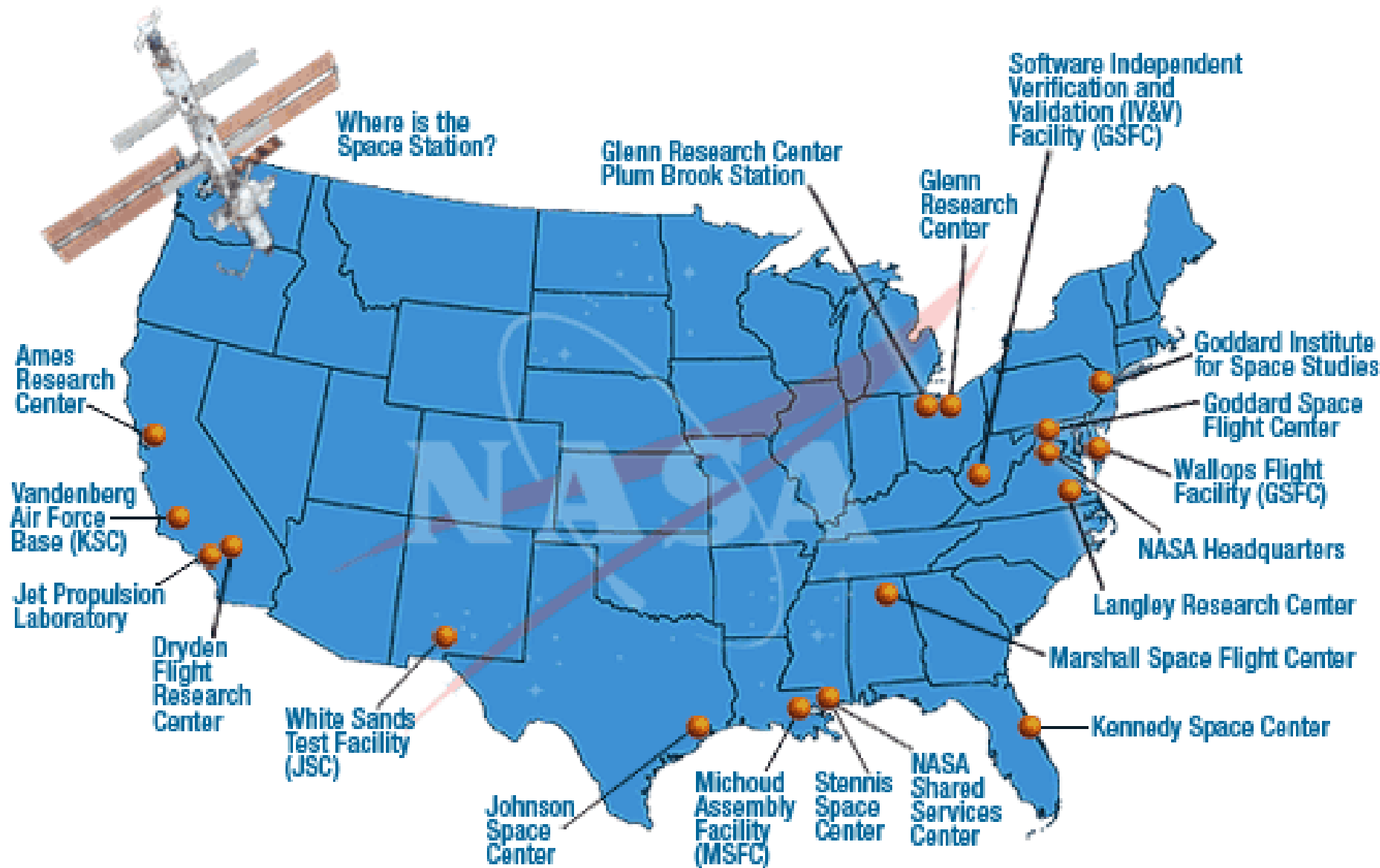

# NASA GSFC One World-Class Organization

What makes Goddard one-of-a-kind?

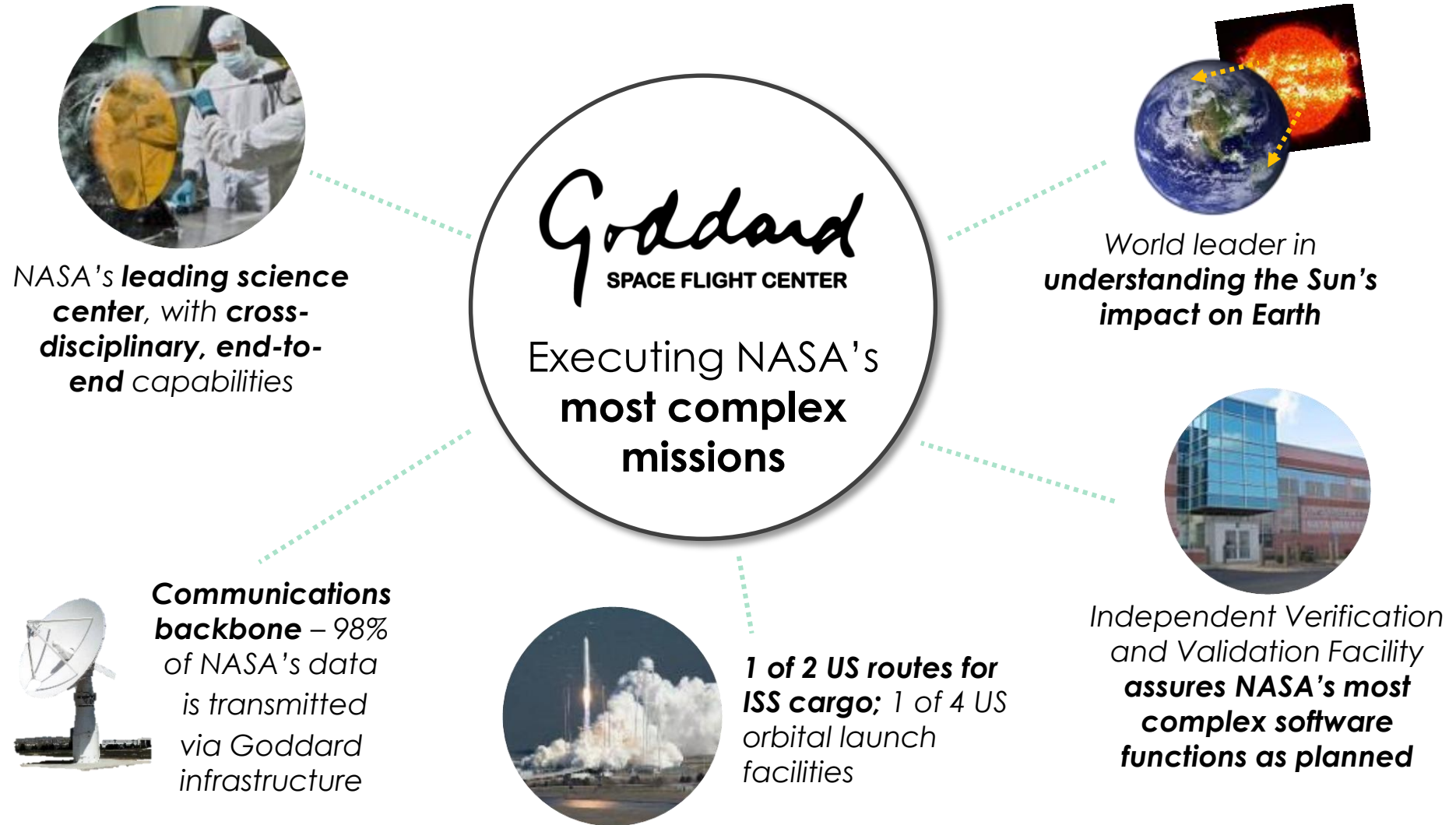

# Who We Are



## THE GODDARD COMMUNITY

More than 10,000 People

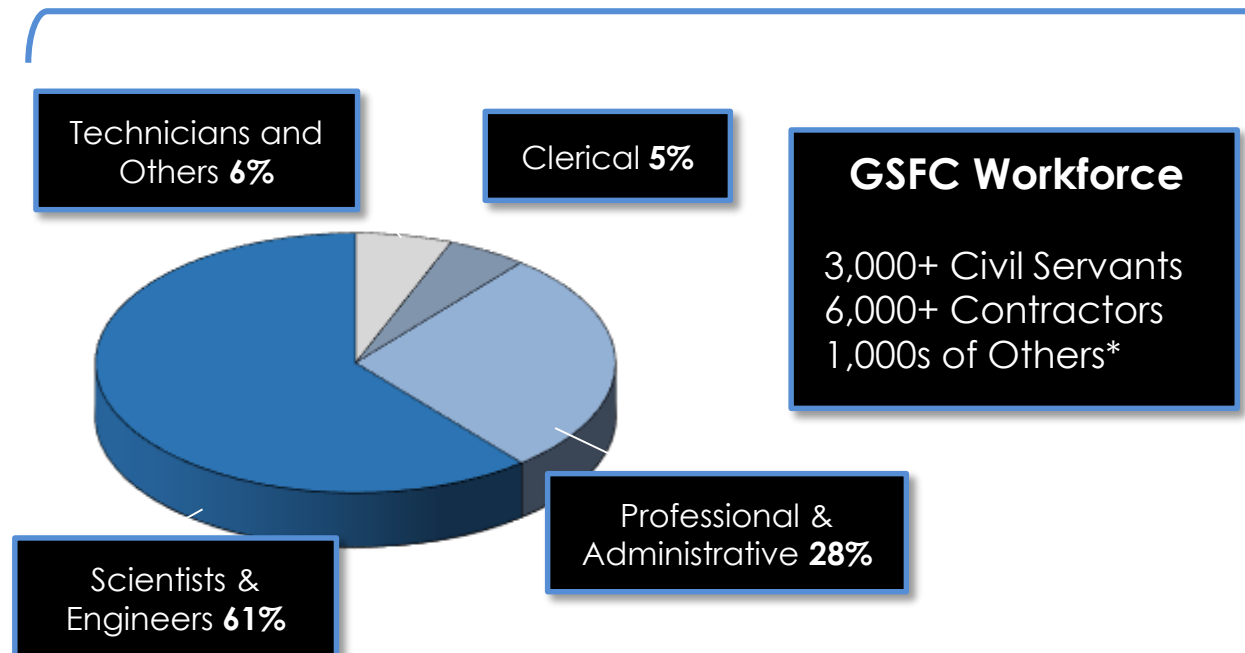

The Nation's largest community of  
**scientists, engineers, and technologists**

\*Including off-site contractors, interns, and Emeritus

# GSFC: A Diverse Mission Portfolio

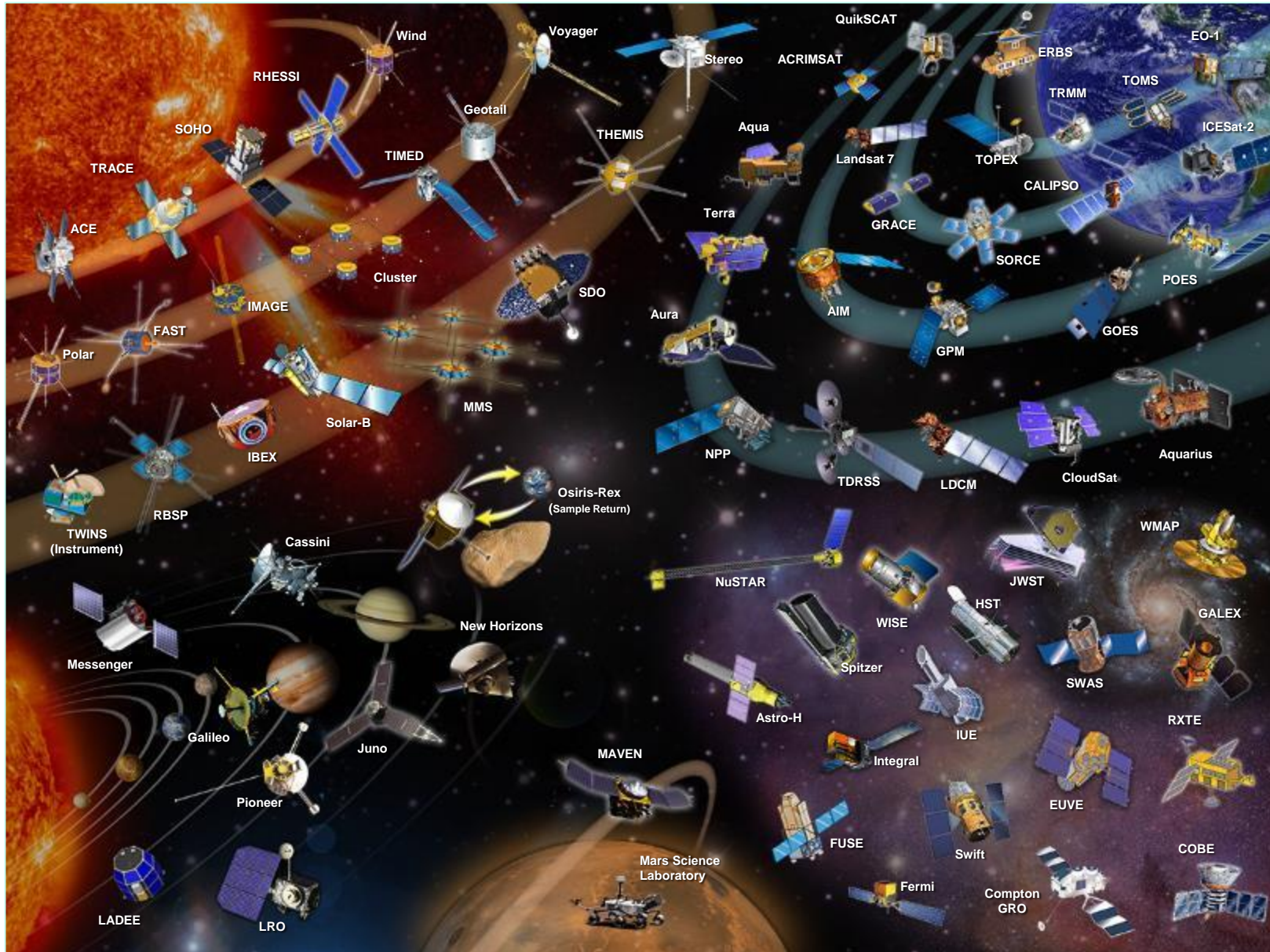

# What is Reliability?

Reliability is the ability of a product to properly function, within specified performance limits, for a specified period of time, under the life cycle application conditions

- Within specified performance limits: A product must function within certain tolerances in order to be reliable.
- For a specified period of time: A product has a useful life during which it is expected to function within specifications.
- Under the life cycle application conditions: Reliability is dependent on the product's life cycle operational and environmental conditions.



# Physics of Failure Perspective of Reliability

Reliability statisticians are interested in tracking system level failure data during the service life for logistical purposes, and in determining how the hazard rate curve looks.

- PoF reliability engineers are interested in understanding and controlling the individual failures that cause the curve.
- PoF engineers do so through systematic and detailed assessment of
  - influence of hardware configuration and life-cycle stresses...
  - on root-cause failure mechanisms...
  - in the materials at potential failure sites.

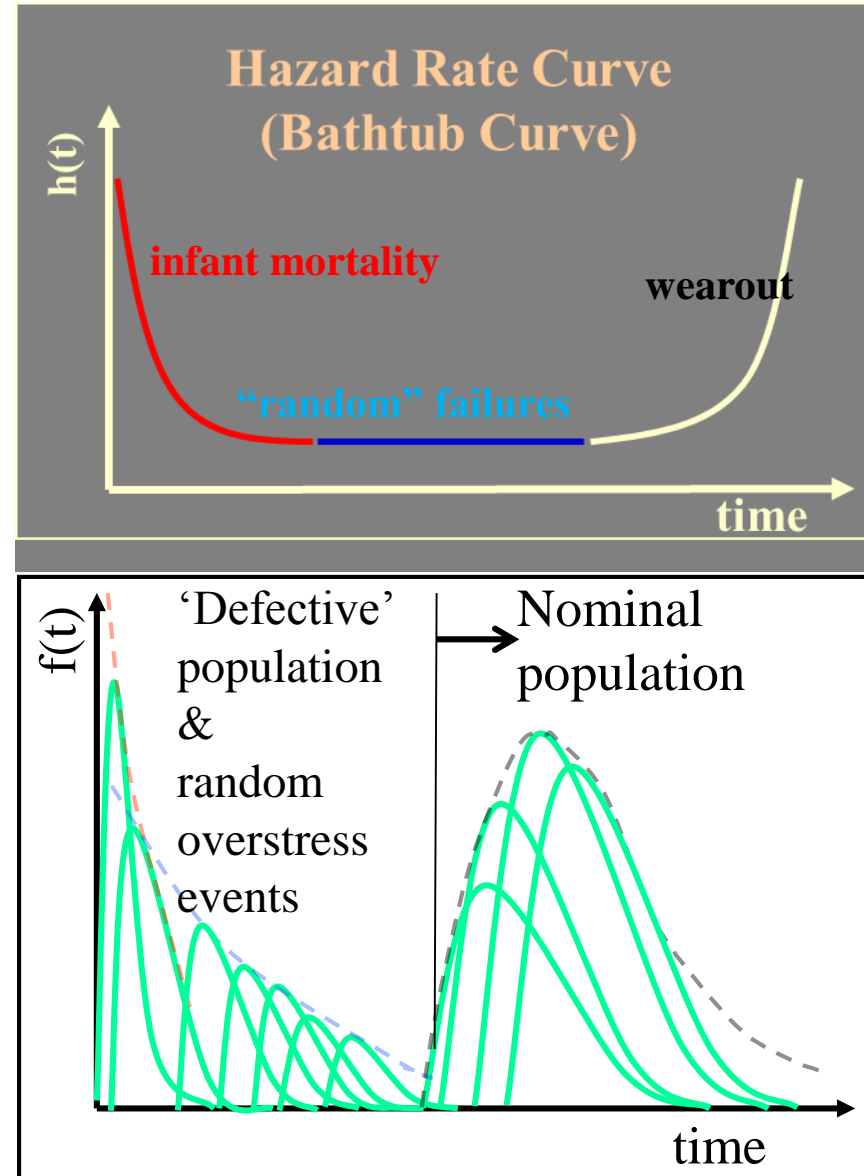

# Influence of 'Durability' and 'Quality' on 'Reliability'

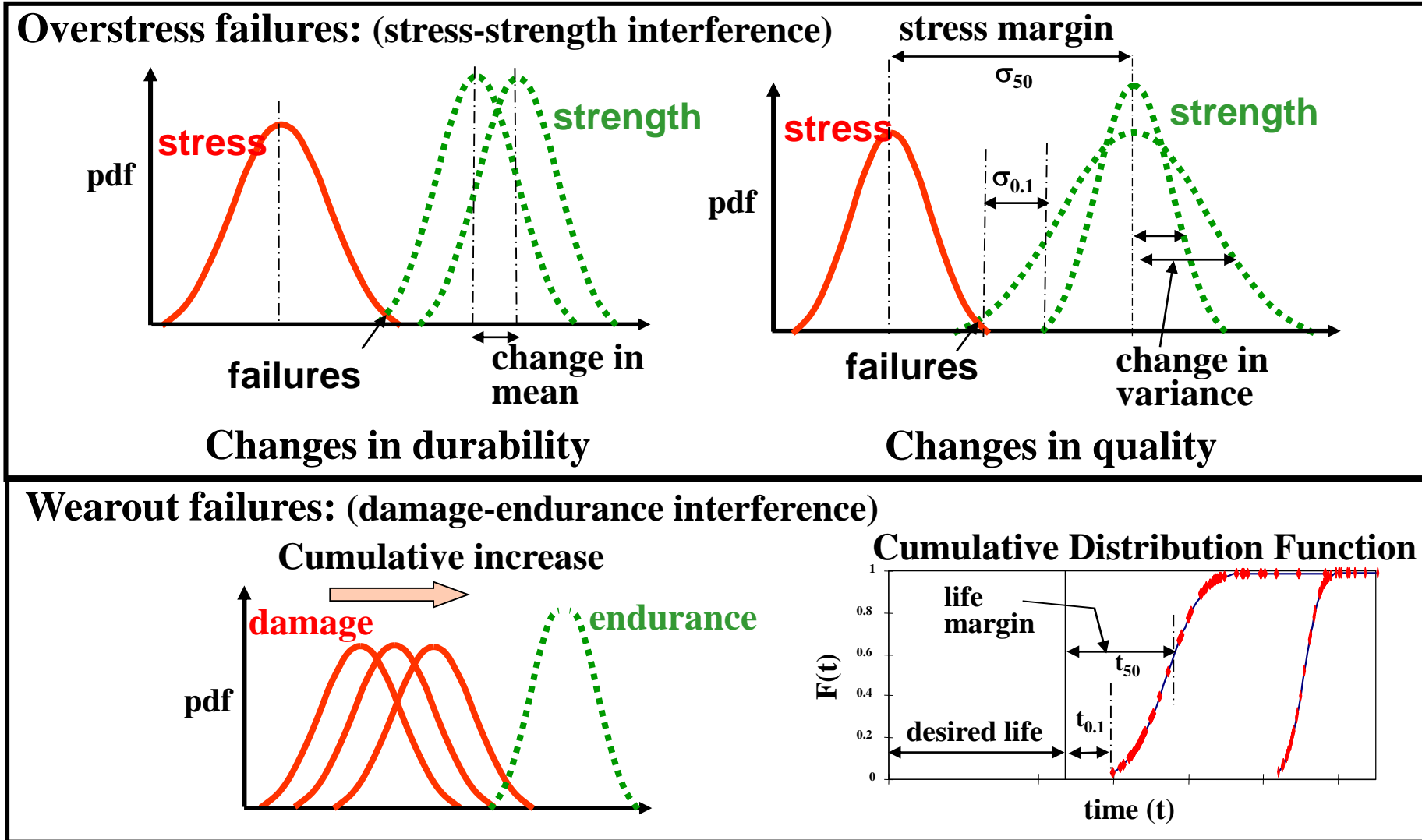

# When a Product Fails, There Are Costs . . .

- To the Manufacturer
  - Time-to-market can increase
  - Warranty costs can increase
  - Market share can decrease. Failures can stain the reputation of a company, and deter new customers.
  - Claims for damages caused by product failure can increase
- To the Customer
  - Personal injury
  - Loss of mission, service or capacity
  - Cost of repair or replacement
  - Indirect costs, such as increase in insurance, damage to reputation, loss of market share

# Failure Definitions

|                   |   |
|-------------------|---|
| Failure           | A product no longer performs the function for which it was intended   |
| Failure Mode      | The effect by which a failure is observed.  |
| Failure Site      | The location of the failure.  |
| Failure Mechanism | The physical, chemical, thermodynamic or other process that results in failure.   |
| Failure Model     | Quantitative relationship between lifetime or probability of failure and loads  |
| Load              | Application/environmental condition needed (electrical, thermal, mechanical, chemical...) to precipitate a failure mechanism. |

# Classification of Failures

- It is helpful to distinguish between two key classes of failure mechanism:
  - *overstress*: use conditions exceed strength of materials; often sudden and catastrophic
  - *wearout*: accumulation of damage with extended usage or repeated stress
- It is also helpful to recognize early life failures:
  - *infant mortality*: failures occurring early in expected life; should be eliminated through process control, part selection and management, and quality improvement procedures

# Failure Mechanism Identification

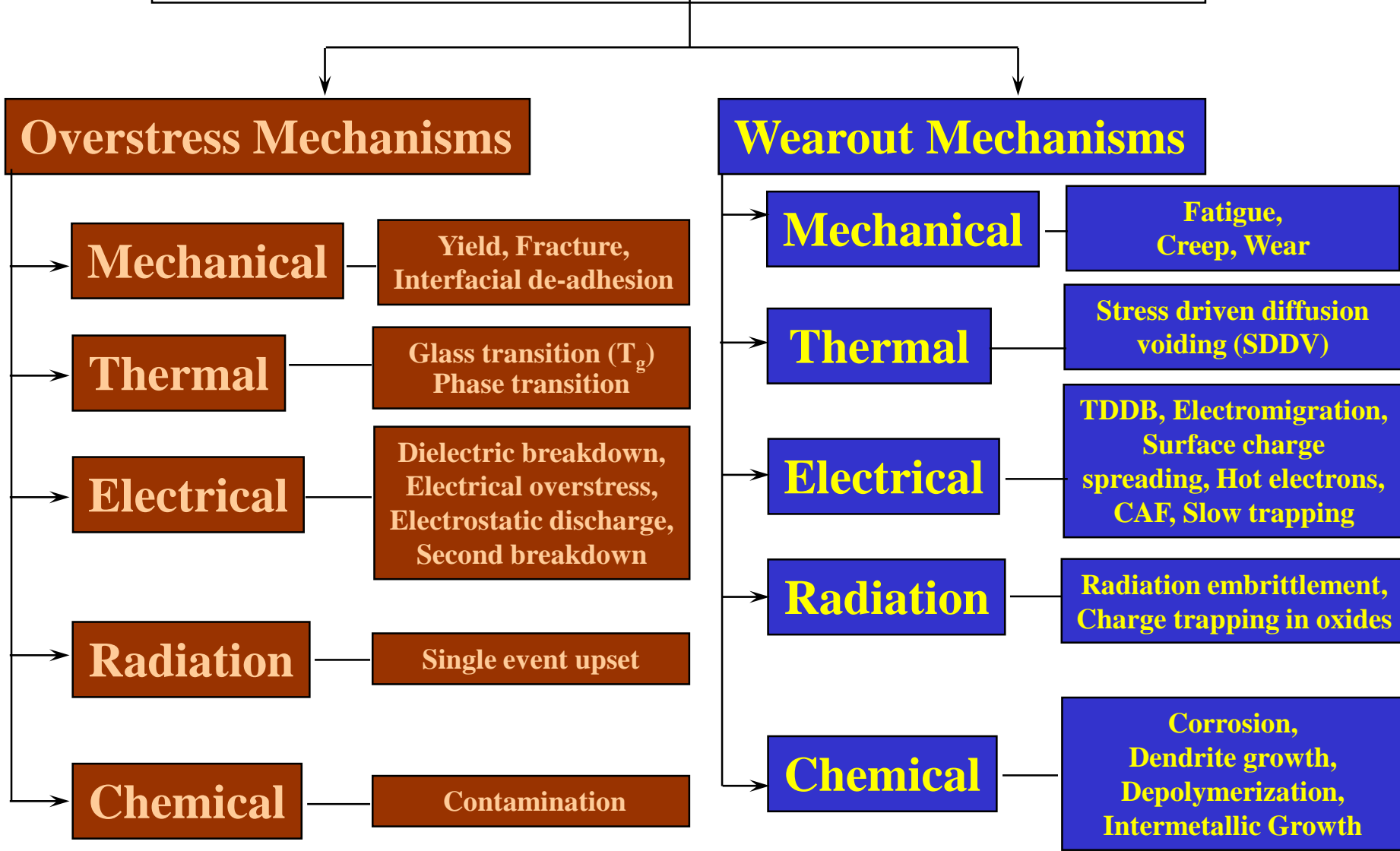

# Cost of a Single Unplanned Data Center Outage Across 16 Industries

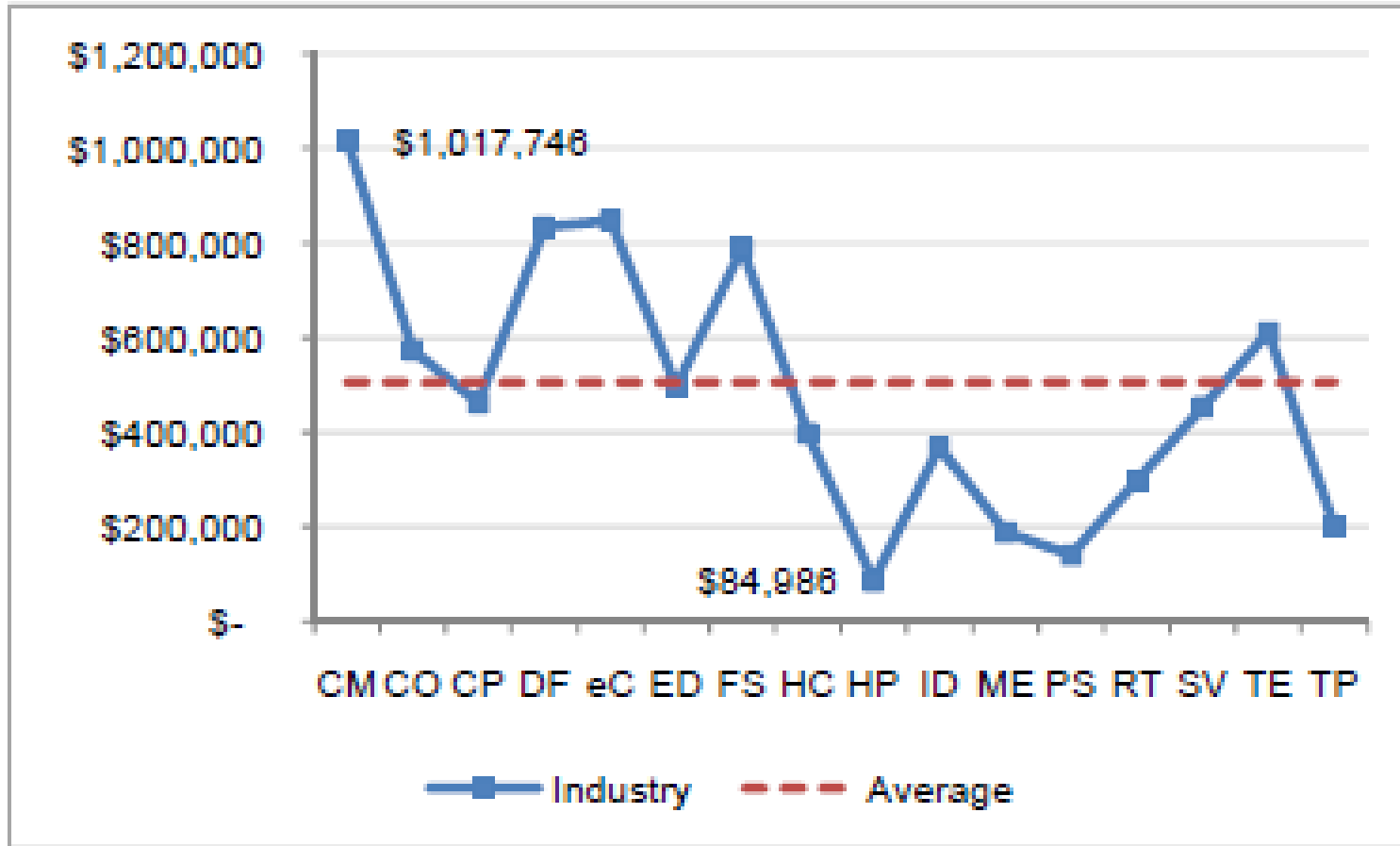

| Industry       | Code |
|----------------|------|
| Communication  | CM   |
| Co-location    | CO   |
| Consumer       | CP   |
| Defense        | DF   |
| eCommerce      | eC   |
| Education      | ED   |
| Financial      | FS   |
| Healthcare     | HC   |
| Hospitality    | HP   |
| Industrial     | ID   |
| Media          | ME   |
| Public sector  | PS   |
| Retail         | RT   |
| Services       | SV   |
| Technology     | TE   |
| Transportation | TP   |

The average cost of data center downtime across industries was approximately **\$5,600 per minute**.

Ref: Ponemon Inst., "Calculating the Cost of Data Center Outages," Feb. 1, 2011.

# Iceberg Model of Cost of Poor Quality

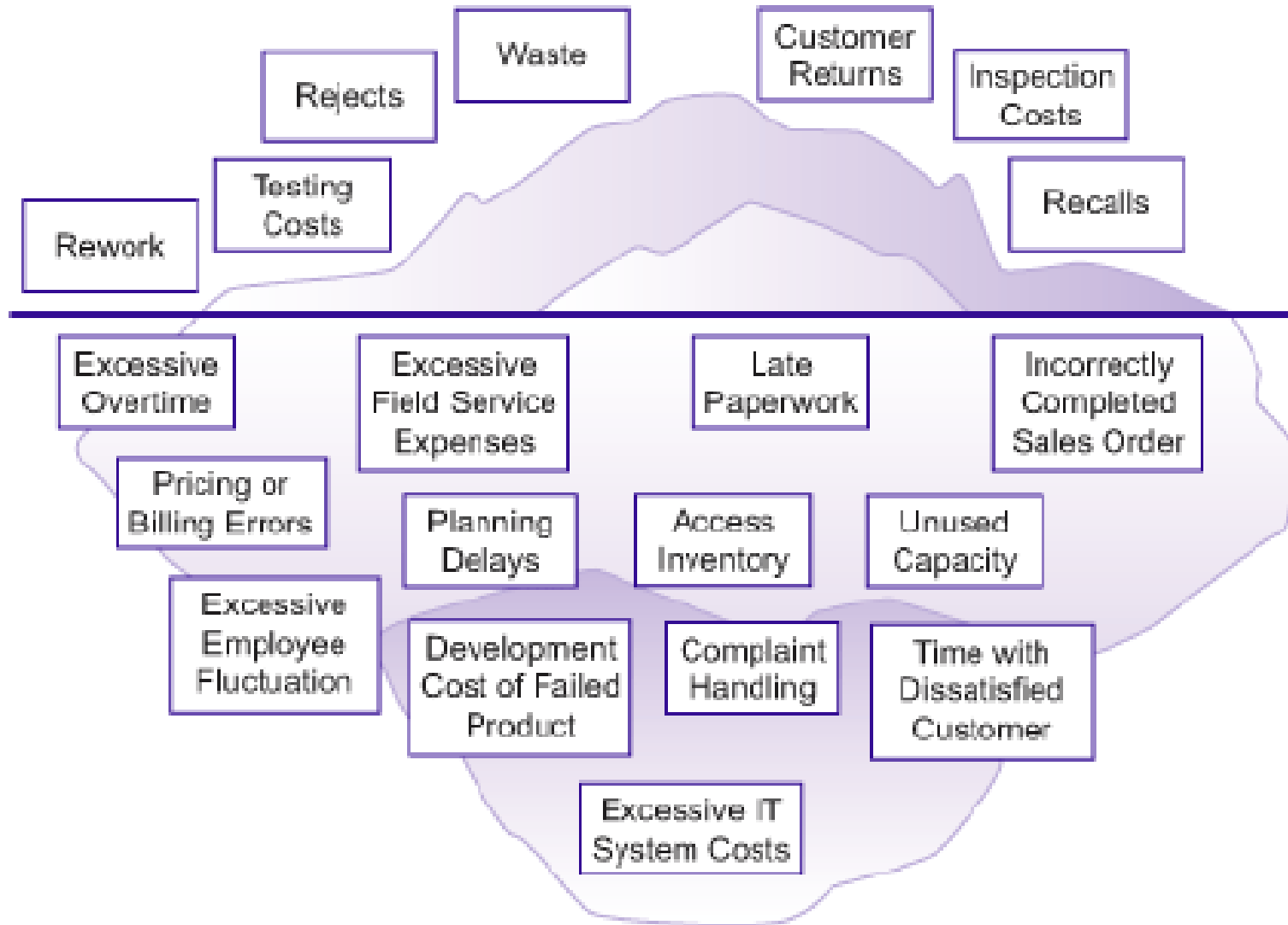

Ref: A. Buthmann, "Cost of Quality: Not Only Failure Costs," iSixSigma.



# Failure Analysis

# What Causes Products to Fail?

Generally, failures do not “just happen.”

Failures may arise during any of the following stages of a product’s life cycle:

- Product design
- Manufacturing
- Assembly
- Screening
- Testing
- Storage
- Packaging
- Transportation
- Installation
- Operation
- Maintenance

The damage (failure mode) may not be detected until a later phase of the life cycle.

# What is Root Cause Analysis?

Root Cause analysis has four major objectives:

- Verify that a failure occurred;
- Determine the symptom or the apparent way a part has failed (the mode);
- Determine the mechanism and root cause of the failure;
- Recommend corrective and preventative action.

While generally synonymous, “Failure analysis” is commonly understood to include all of this except determination of root cause.

# What is a Root Cause?

**The root cause is the most basic causal factor or factors that, if corrected or removed, will prevent the recurrence of the situation.\***

The purpose of determining the root cause(s) is to fix the problem at its most basic source so it doesn't occur again, even in other products, as opposed to merely fixing a failure symptom. Identifying root causes is the key to preventing similar occurrences in the future.

Ref: ABS Group, Inc., *Root Cause Analysis Handbook, A Guide to Effective Incident Investigation*, ABS Group, Inc., Risk & Reliability Division, Rockville MD.

# Root Cause Analysis is Different from Troubleshooting

- Troubleshooting is generally employed to eliminate a symptom in a given product, or to identify a failed component in order to effect a repair.
- Root cause analysis is dedicated to finding the fundamental reason why the problem occurred in the first place, to prevent future failures.

# From Symptoms to Root Causes

- **Symptoms** are manifestations of a problem; signs indicating that a failure exists.
  - Example: a symptom of printed circuit board failure could be the measurement of open circuits after fabrication.
- **An apparent cause (or immediately visible cause)** is the superficial reason for the failure.
  - Example: the apparent cause of open circuits could be that traces have discontinuities that result in open circuits.
- **Root Cause** is the most basic casual factor(s).
  - Example: the root cause could arise during the manufacturing process if the circuit boards are stacked improperly, resulting in scratches to circuit traces. Another possible root cause could be the presence of contaminants during the copper trace etching process, which resulted in discontinuities in the traces.

# Root Cause Analysis

- Root cause analysis is a methodology designed to help:
  - 1) Describe WHAT happened during a particular occurrence,
  - 2) Determine HOW it happened, and
  - 3) Understand WHY it happened.
- Only when one is able to determine WHY an event or failure occurred, will one be able to determine corrective measures, and over time, the root causes identified can be used to target major opportunities for improvement.
- Uncovering ROOT CAUSE may require 7 iterations of “Why?”

# Root Cause Analysis Process

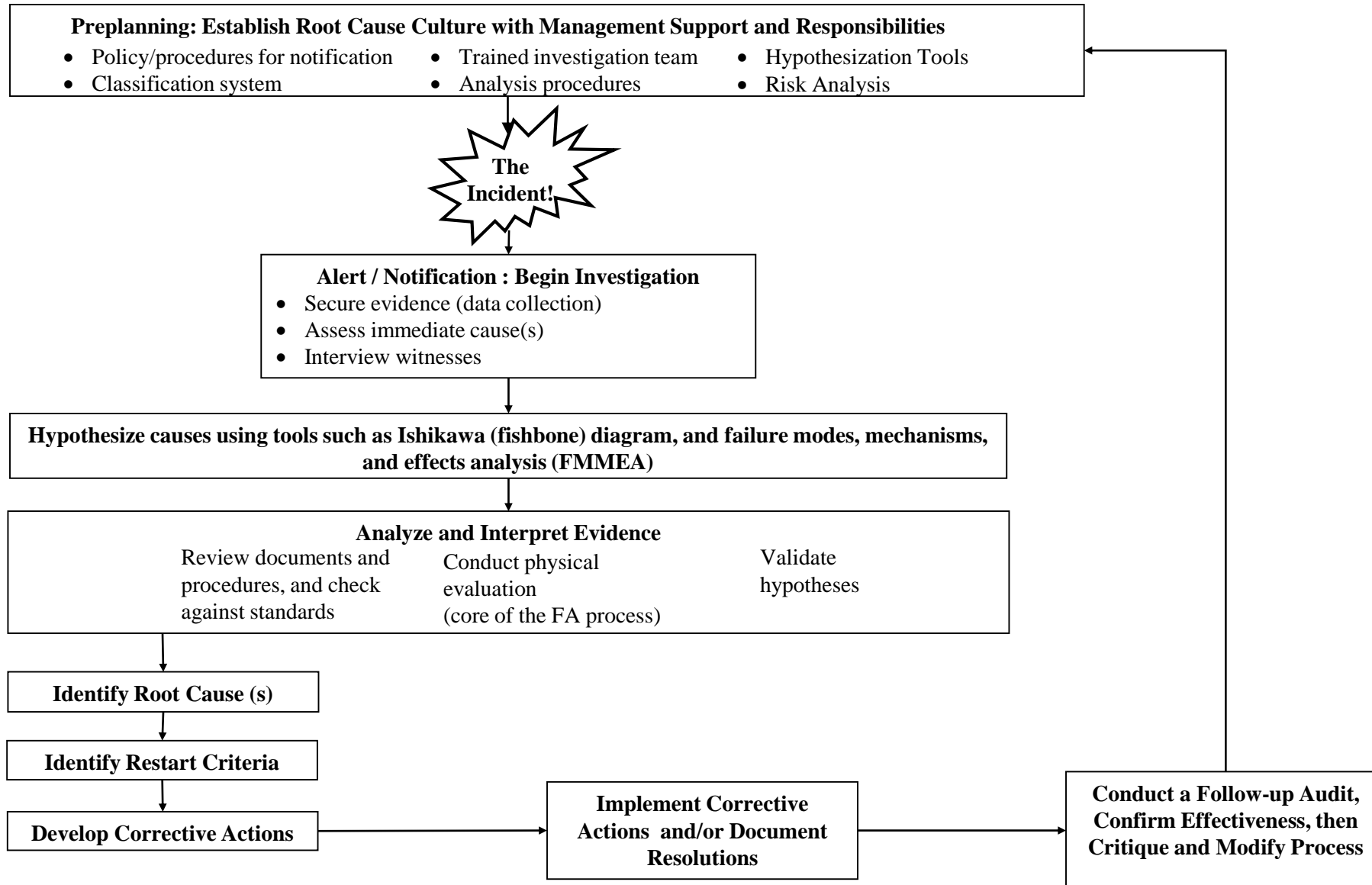



# Pre-planning Activities

- Establish a root cause culture (management support)
  - Awareness and education
  - Investigation procedures
  - Teams that can be activated quickly after an incident occurs
- Develop a failure classification system of failures
  - Aids in the documentation of failures and their root-causes
  - Help identify suitable preventive methods against future incidents.
- Form a multi-disciplinary team of investigators
  - Complex failures often require *expertise in many disciplines*.
- Define analysis strategies and procedures:
  - How to notify and report product equipment failure?
  - When to perform root cause analysis (e.g., for every failure? repeated failures? for what type of failures?)
  - What root cause hypothesization techniques (e.g., FMMEA, FTA) are most suited to identify specific failures?
- Provide training in the analysis techniques and their application, to personnel directly involved in root cause investigation.

# Data Collection

- The objective of data collection is to **understand the events and the major causal factors** associated with the incident that led to the failure.
- The evidence gathered will be used to identify the critical aspects of failure, including the failure mode, site, and mechanism, time in the life-cycle where failure occurred, length of time required for the failure to initiate, and periodicity of the failure.
- The 5-Ps of data collection:
  - People
  - Physical evidence
  - Position (physical, time-event sequences, functional relationships)
  - Paper (procedures, manuals, logs, e-mails, memos)
  - Paradigms (view of situations and our response to them)
- Data gathering must be performed **as soon as possible after the event occurs** in order to prevent loss or alteration of data that could lead to root cause.
- A huge amount of information is not the goal of data collection. Unrelated data often cause confusion.

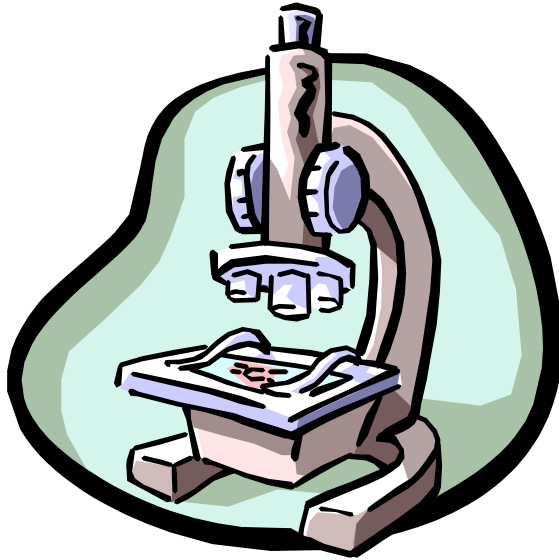

# Hypothesizing Causes

Hypothesizing causes is the process of applying knowledge of risks associated with a product's design and life cycle to the data gathered about the failure event, in order to postulate a root cause.

- Tools for hypothesizing causes:
  - Failure modes, and effects analysis (FMEA)
  - Fault tree analysis (FTA)
  - Cause and effect diagram – Ishikawa diagram (fishbone analysis)
  - Pareto analysis

# Tools for Hypothesizing Root Causes

# FMEA Methodology

- Failure modes and effects analysis is an approach for identifying all possible failures in a design, a manufacturing or assembly process, or a product or service.
- Knowledge of stresses is combined with failure models to **prioritize failure mechanisms** according to their severity and likelihood of occurrence.

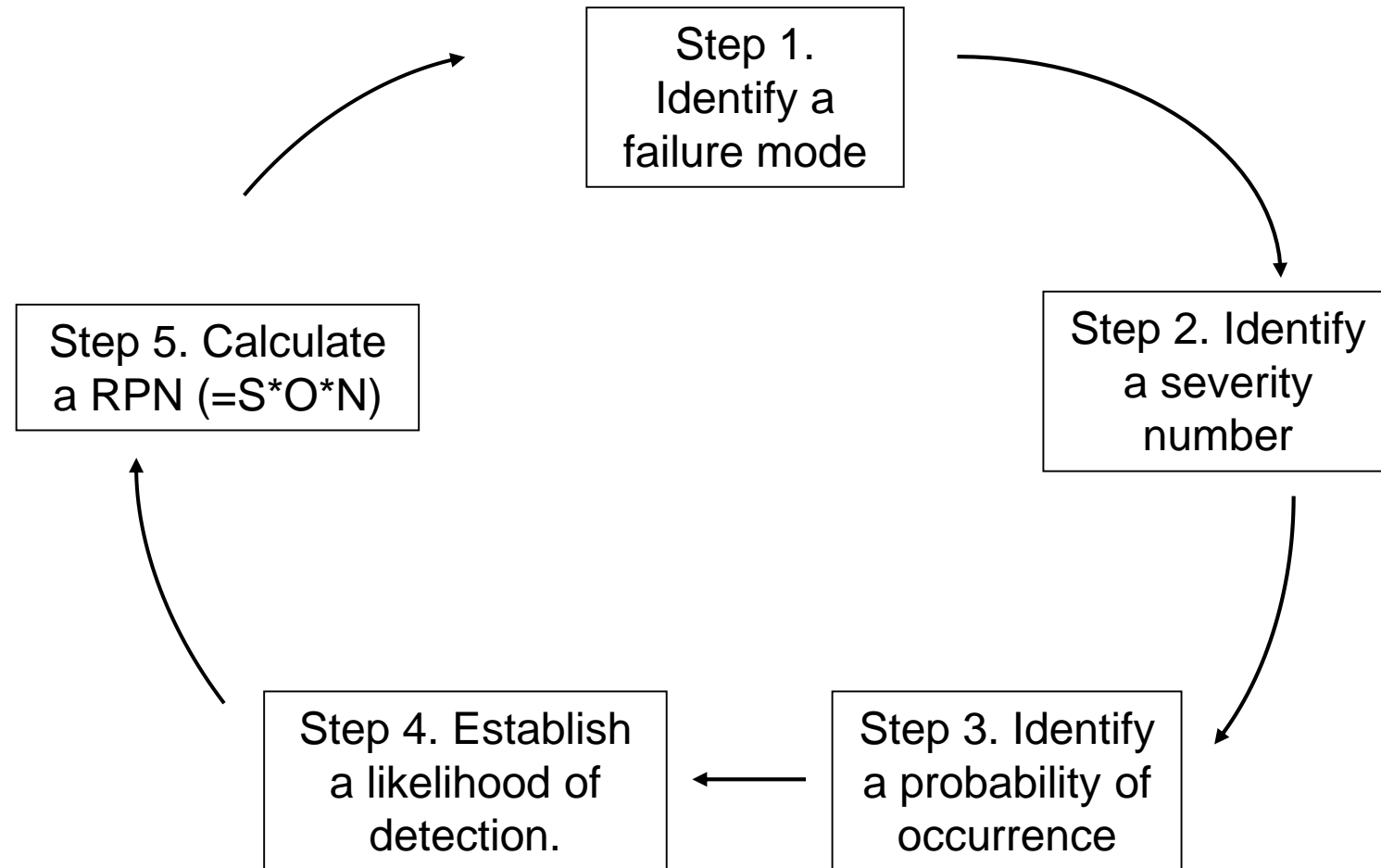

# Fault Tree Analysis

- In contrast with the “bottom up” assessment of FMEA, fault-tree is a “top down” analysis that starts qualitatively to **determine what failure modes can contribute to an undesirable top level event.**
- It aims at developing the structure from which simple logical relationships can be used to express the probabilistic relationships among the various events that lead to the failure of the system.

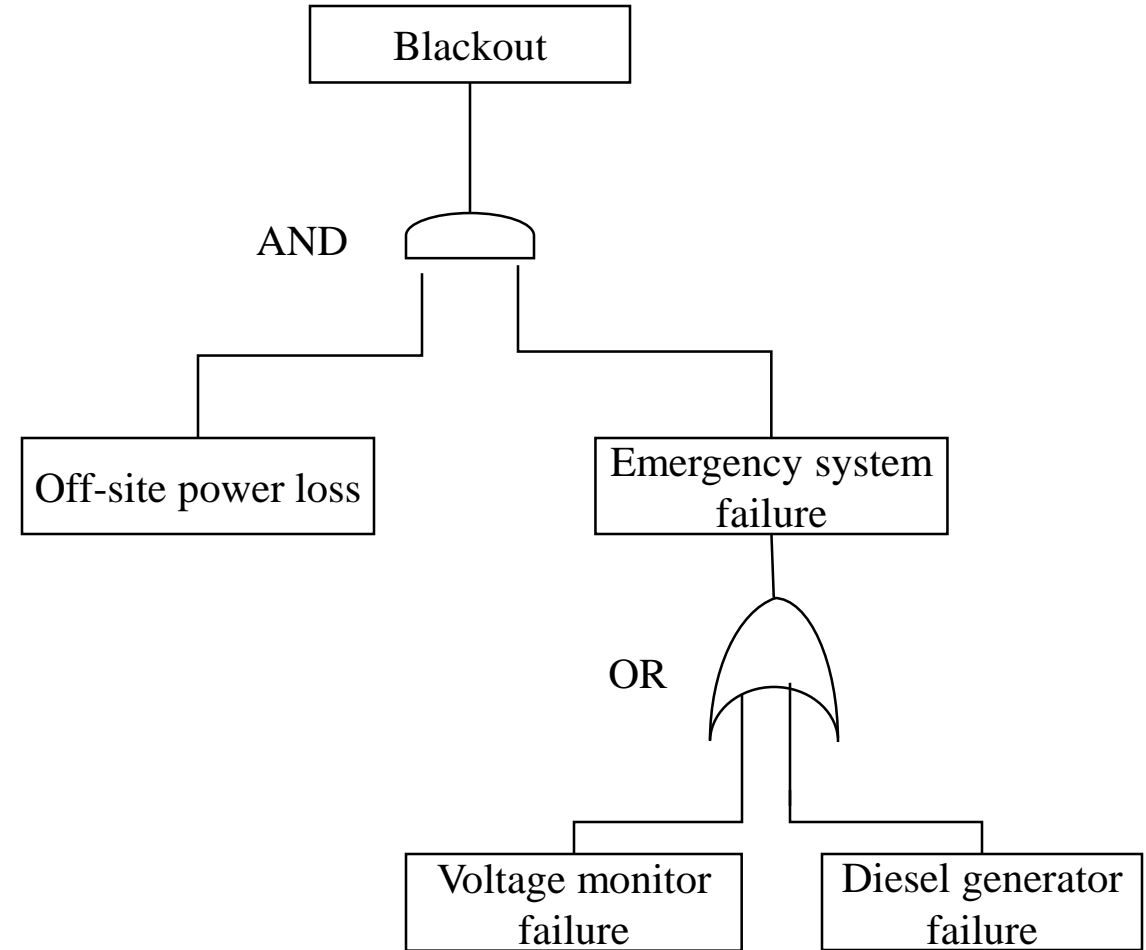

# Cause and Effect Diagram (Electrical Opens in PCBs)

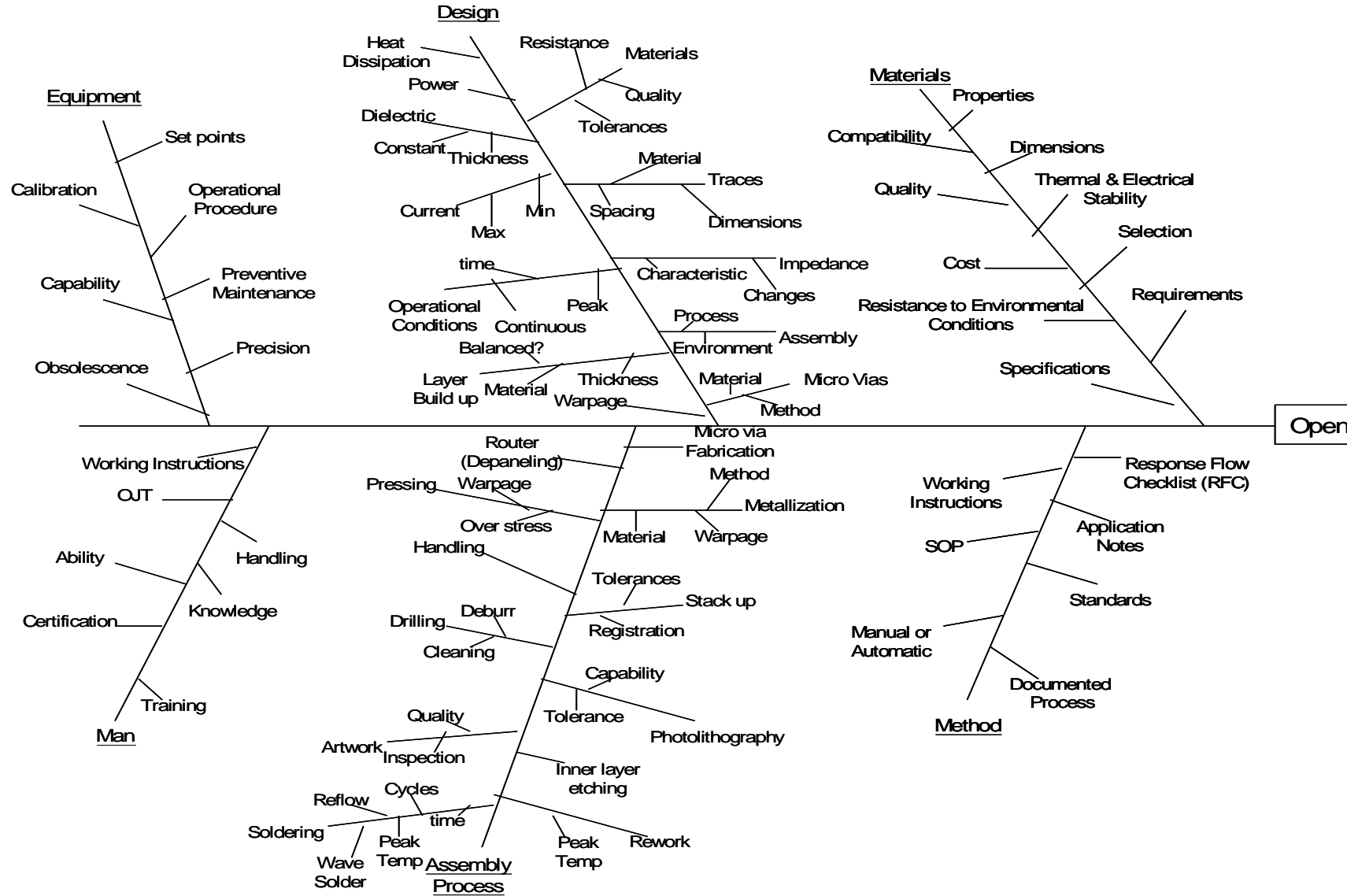

Ref: Coombs C. F. "Printed circuits handbook." Printed Circuits Handbook. McGraw-Hill Professional Publishing (2007).

# Cause and Effect Diagram (Electrical Shorts in PCBs)

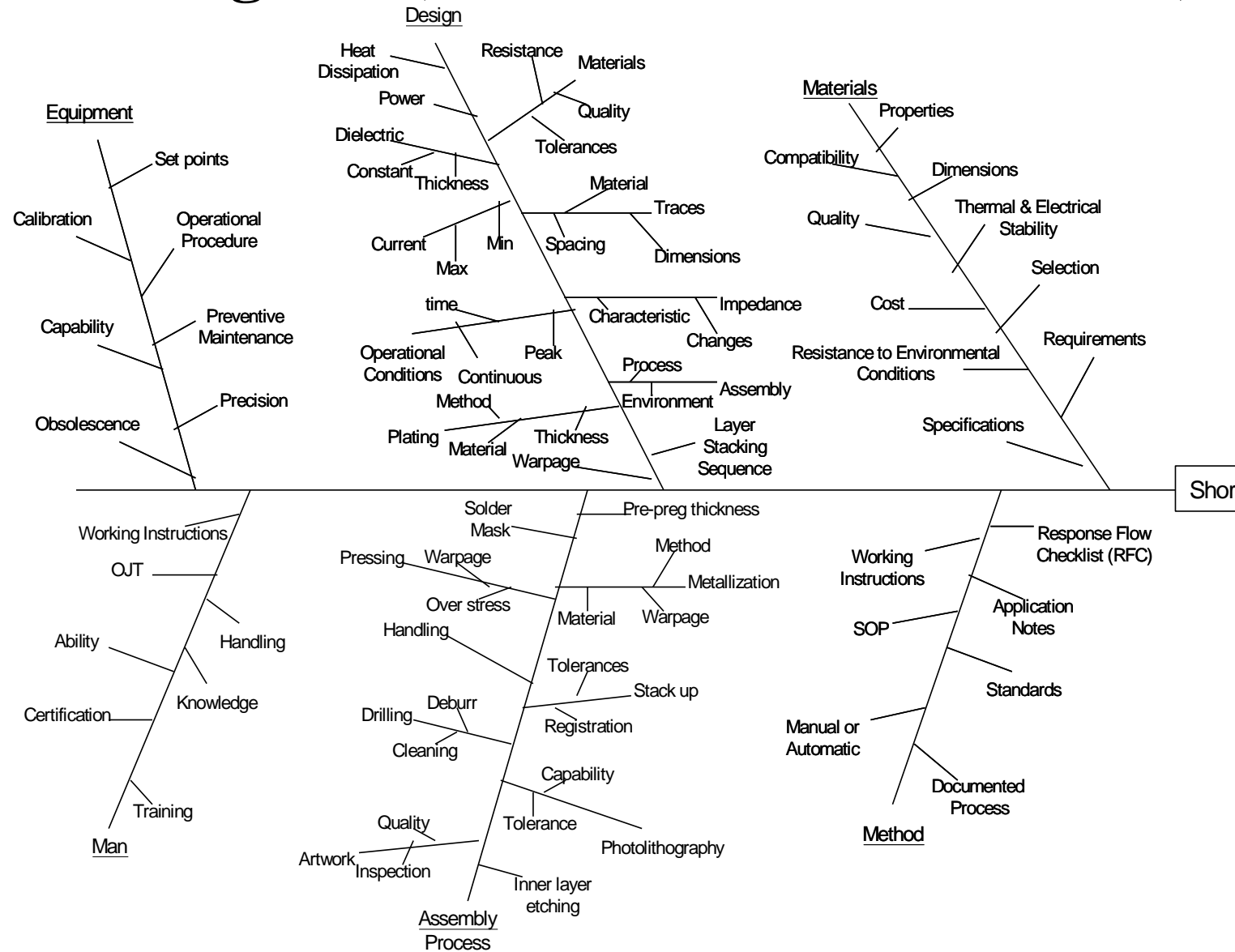

Ref: Sood B., and Pecht M., 2011. Printed Circuit Board Laminates. Wiley Encyclopedia of Composites. 1-11.



# Cause and Effect Diagram (Delamination in PCBs)

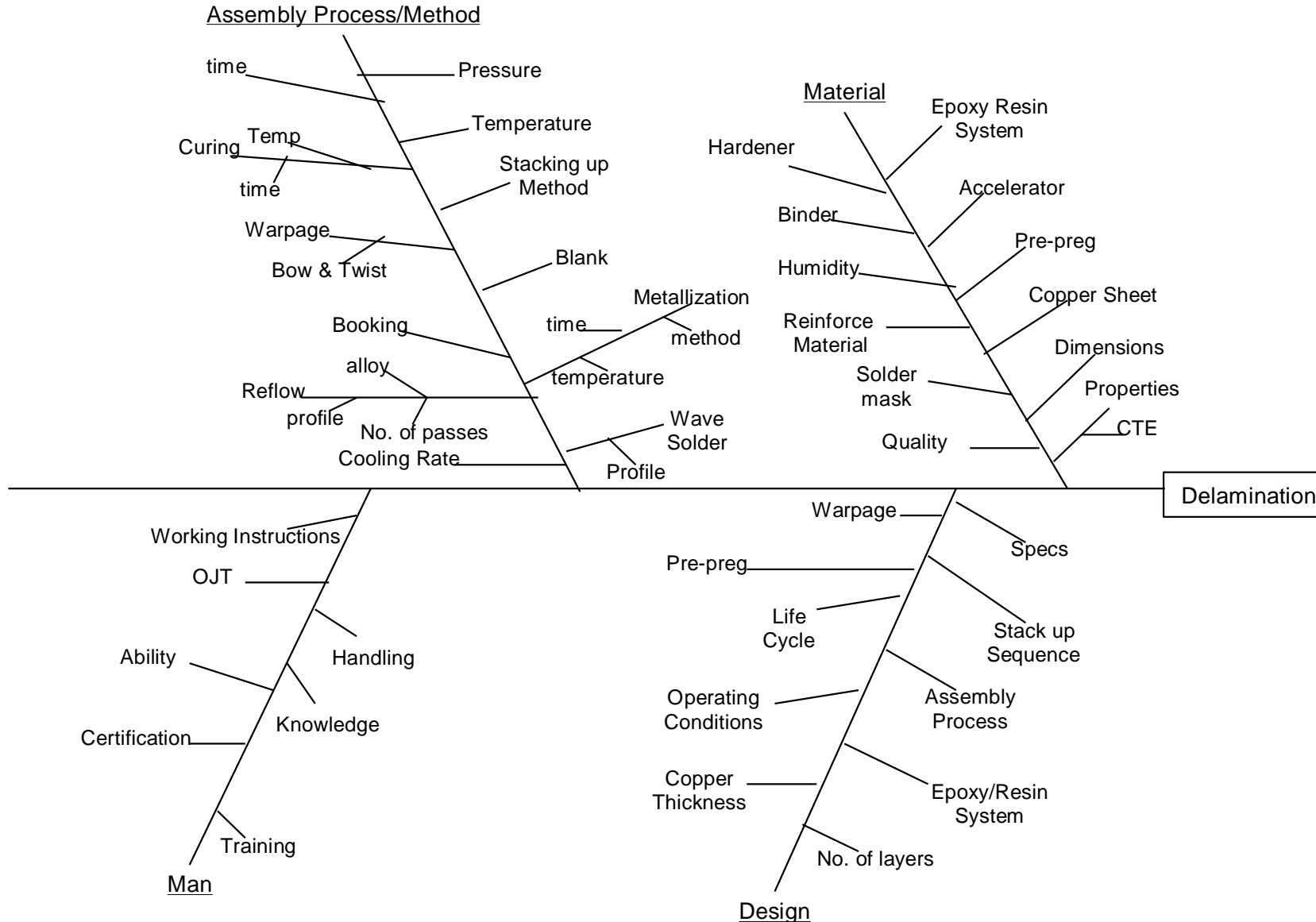

Ref: Sood B., and Pecht M., 2011. Printed Circuit Board Laminates. Wiley Encyclopedia of Composites. 1-11.

# Pareto Chart Example

## - Failure Causes in Electronic Devices -

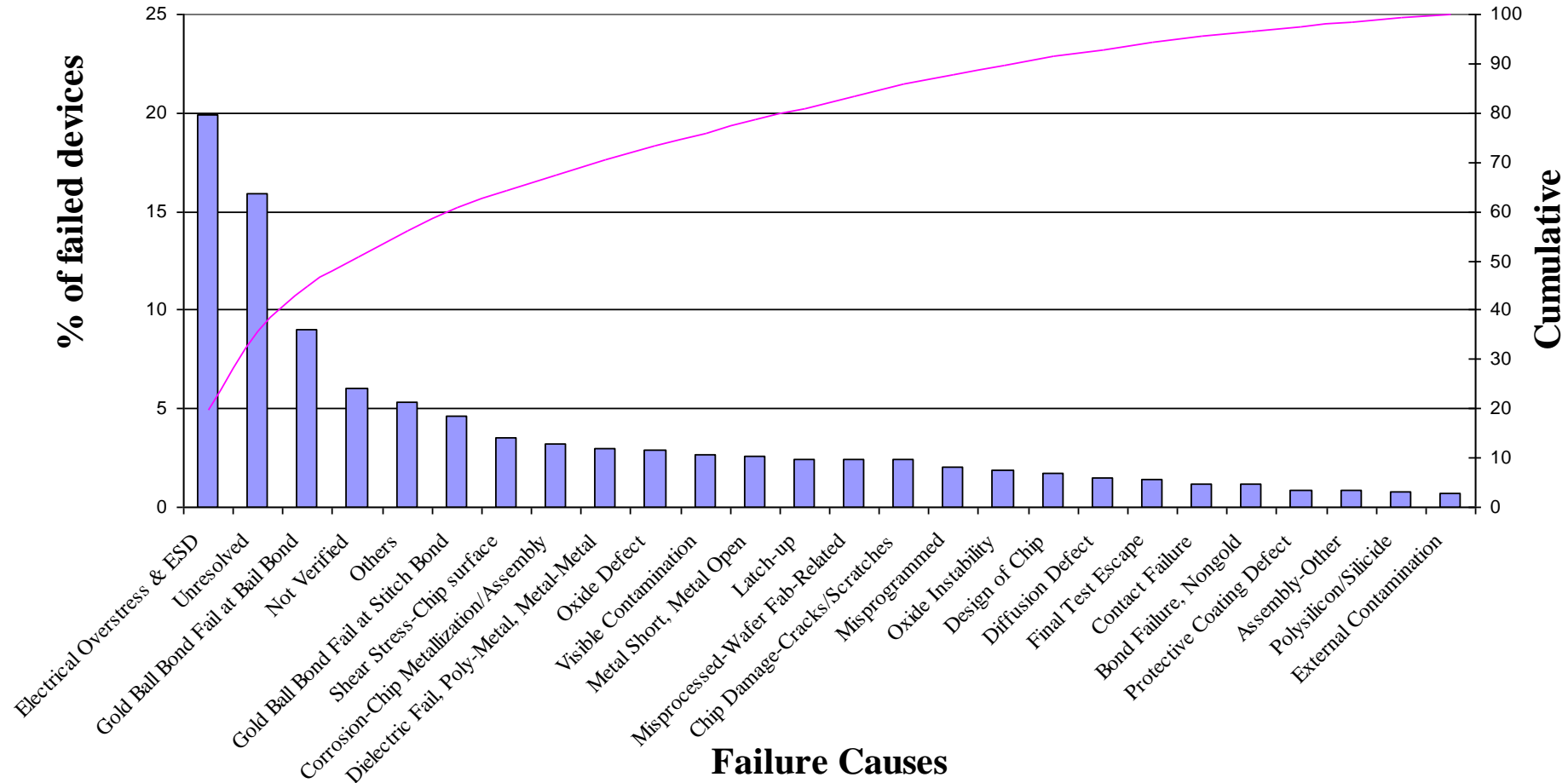

Ref: Pecht M. and V. Ramappan: "Review of Electronic System and Device Field Failure Returns," *IEEE Transactions on CHMT*, Vol. 15, No. 6, pp. 1160-1164, 1992.

# Collecting Supporting Evidence

- Even if a root cause has been hypothesized, additional evidence is often required to assess (i.e., prove or invalidate) the hypotheses formulated.
- Evidence can be gathered by
  - undertaking sample physical evaluation.
  - reviewing documents and procedures against standards, and
  - interviews

# Analysis and Interpretation of Evidence

- Reviewing in-house procedures
  - (e.g., design, manufacturing process, procurement, storage, handling, quality control, maintenance, environmental policy, safety, communication or training procedures)
- ...against corresponding standards, regulations, or part- and equipment vendor documentation
  - (e.g., part data sheet and application notes, equipment operating and maintenance manuals)
- ....can help identify causes such as misapplication of equipment, and weakness in a design, process or procedure.
  - Example 1: misapplication of a component could arise from *its use outside the vendor specified operating conditions* (e.g., current, voltage, or temperature).
  - Example 2: equipment (e.g., assembly, rework or inspection equipment) misapplication can result from *uncontrolled modifications or changes* in the operating requirements of the machine.
  - Example 3: a defect may have been introduced due to *misinterpretation* of poorly written assembly instructions.

# General Approach Used for Failure Analysis

- The overriding principle of failure analysis is to *start with the least destructive methods and progress to increasingly more destructive techniques.*
- The potential for a nominally non-destructive technique to cause irreversible changes should not be underestimated.
  - For example, the simple act of handling a sample, or measuring a resistance, can cause permanent changes that could complicate analysis further down the line.
- Each sample and failure incidence may require a unique sequence of steps for failure analysis. The process demands an *open mind, attention to detail, and a methodical approach.*

# Example of Failure Analysis Process Flow

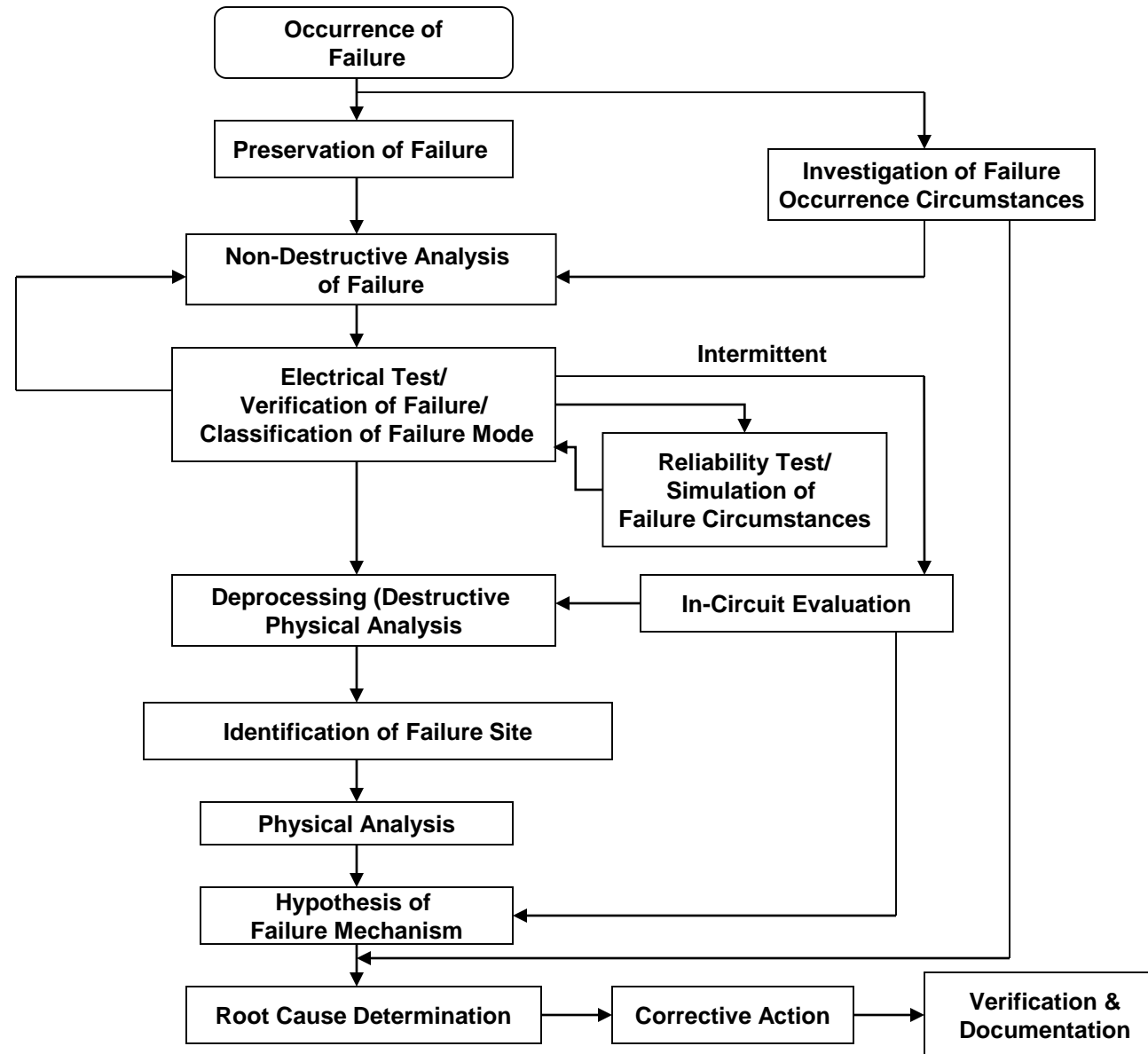

# Non-Destructive Testing (NDT)

- Visual Inspection
  - Optical Microscopy
  - X-ray imaging
  - X-ray Fluorescence Spectroscopy
- 
- Acoustic microscopy
  - Residual gas analysis
  - Hermeticity Testing

# External Inspection

- Visual inspection of external condition
  - Differences from good samples
  - May require exemplars
- Detailed inspection: appearance, composition, damage, contamination, migration, abnormalities
  - Low power microscope
  - High power microscope
  - Scanning electron microscope (SEM)



# Electrical Testing

- Electrical characteristics/performance
- DC test
- Parametrics (current-voltage characteristic)
- Simulated usage conditions
- Electrical probing

# Deprocessing: Destructive Physical Analysis (DPA)

- Modification of specimen in order to reveal internal structures and analyze failure site. May involve:
  - Cross-sectioning and metallography
  - Decapsulation or delidding
  - Residual Gas Analysis for internal gases



1x Magnification:  
Before Decapsulation

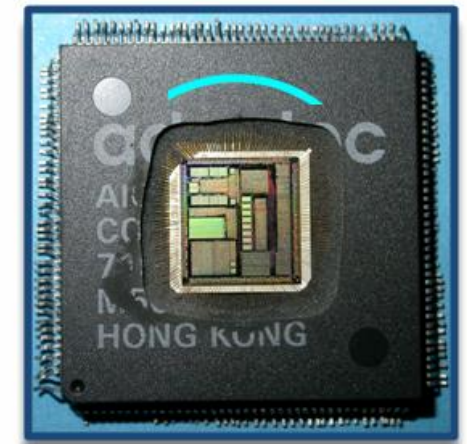

1x Magnification:  
After Decapsulation\*

# Fault Isolation

- Electrical Probing
- Time Domain Reflectometry (TDR)
- Electron Beam Testing
  - electron beam induced current (EBIC),
  - voltage contrast (VC),
  - cathodoluminescence (CL)
- Emission Microscopy
- Scanning Probe Microscopy
- Thermal Analysis

# Physical Analysis of Failure Site

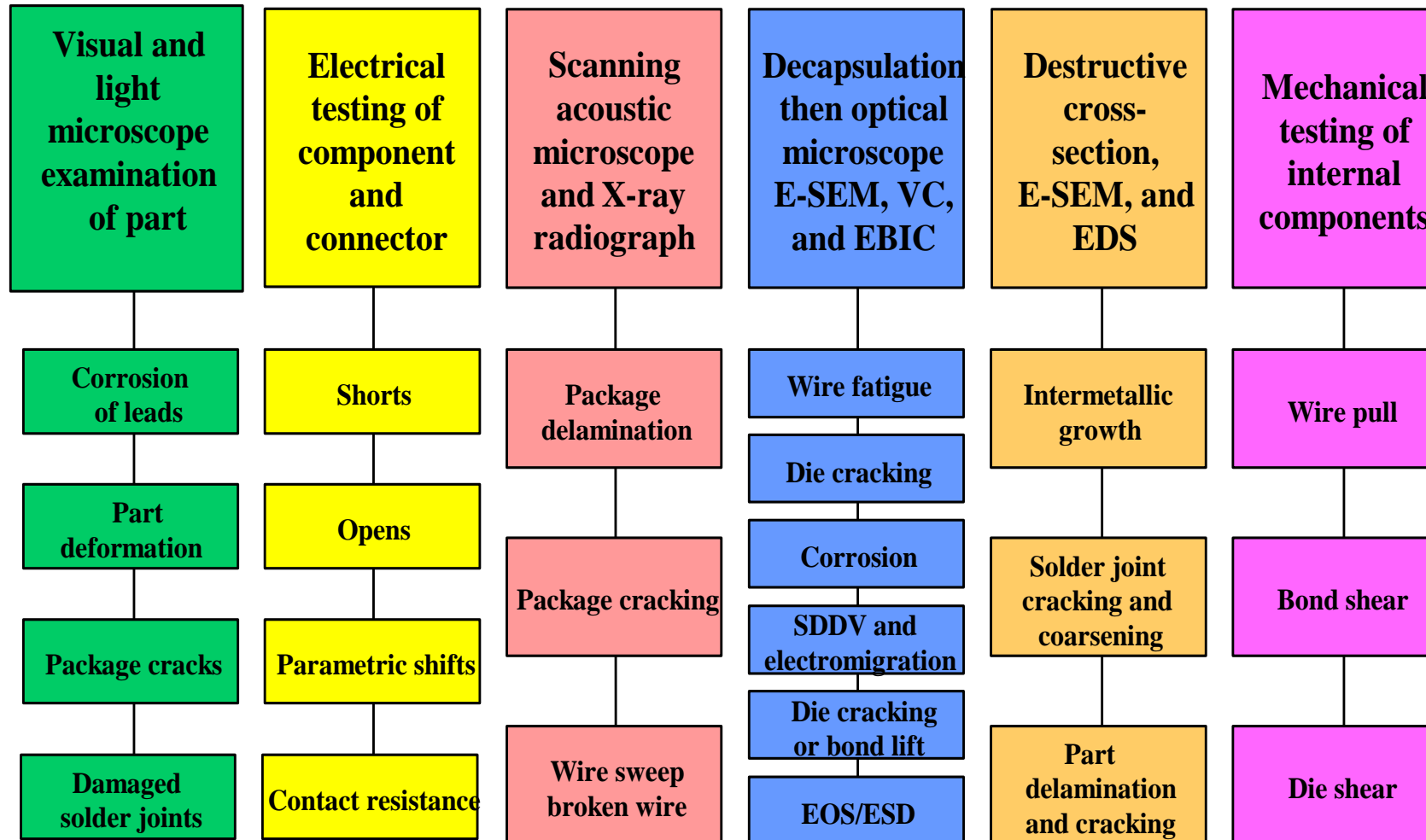

# Root Cause Identification

- Testing may be needed to determine the effect of hypothesized factors on the failure.
- A design of experiment (DoE) approach is recommended to incorporate critical parameters and to minimize the number of tests.
- This experimentation can validate a hypothesized root cause.

# Discussion 1 – $\mu$ QFN\* (micro-leadframe QFN)

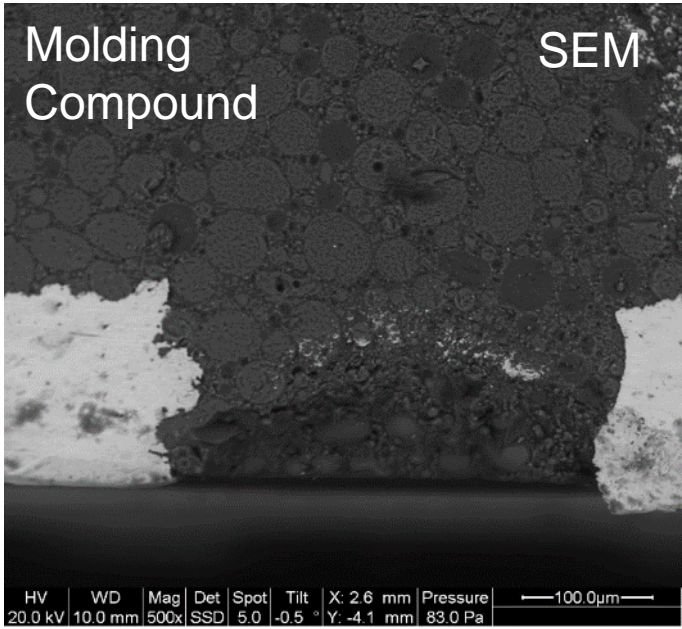
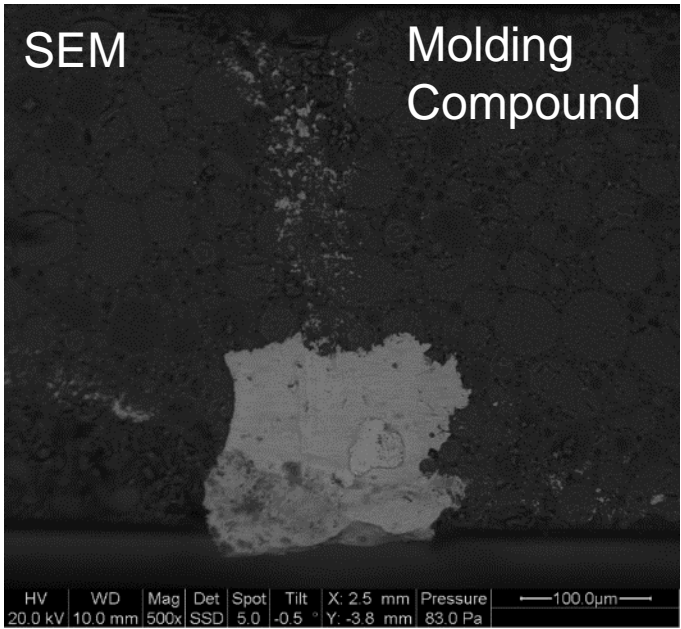
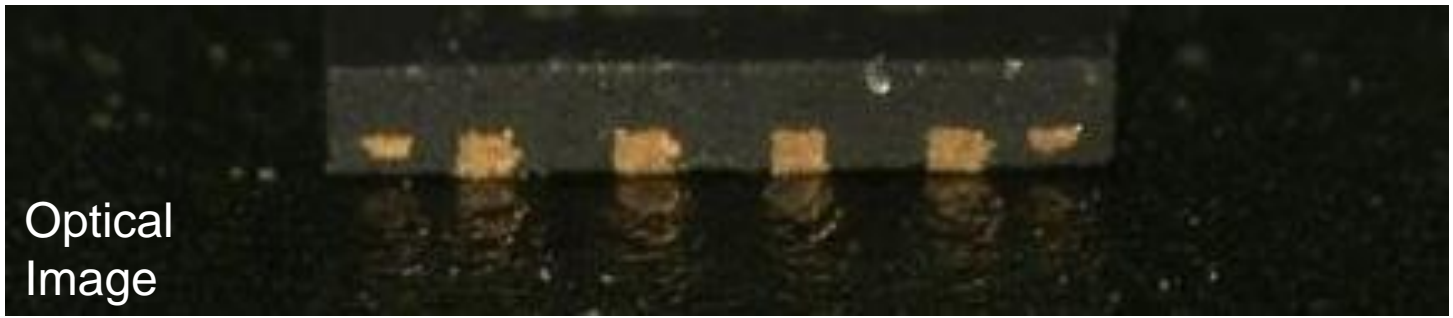

What is the failure mode, failure mechanism, root cause and corrective action?

\* - Michael Osterman, CALCE, University of Maryland

# Failure Mechanisms

# Review: Failure Definitions

|                          |  |
|--------------------------|--|
| Failure                  | A product no longer performs the function for which it was intended                    |
| Failure Mode             | The effect by which a failure is observed.   |
| Failure Site             | The location of the failure.   |
| <b>Failure Mechanism</b> | <b>The physical, chemical, thermodynamic or other process that results in failure.</b> |

In principle, it should be possible to develop a **failure model** for a specific failure mechanism, expressing the likelihood of failure (time-to-failure, probability of failure, strength, etc.) as a function of the stresses and characteristics of the material.



# Review: Classification of Failures

## Key classes of failure:

- ***overstress***: use conditions exceed strength of materials; often sudden and catastrophic
- ***wearout***: accumulation of damage with extended usage or repeated stress
- ***infant mortality***: failures early in expected life; typically related to quality issues.

# Examples of Failure Models

| Failure Mechanism                    | Failure Sites  | Relevant Stresses   | Sample Model                        |
|--------------------------------------|--|---|-------------------------------------|
| Fatigue                              | Die attach, Wirebond/TAB, Solder leads, Bond pads, Traces, Vias/PTHs, Interfaces | Cyclic Deformations<br>( $\Delta T$ , $\Delta H$ , $\Delta V$ ) | Nonlinear Power Law (Coffin-Manson) |
| Corrosion                            | Metallizations   | M, $\Delta V$ , T, chemical                                     | Eyring (Howard)                     |
| Electromigration                     | Metallizations   | T, J  | Eyring (Black)                      |
| Conductive Anodic Filament Formation | Between Metallizations   | M, $\Delta V$   | Power Law (Rudra)                   |
| Stress Driven Diffusion Voiding      | Metal Traces   | $\sigma$ , T  | Eyring (Okabayashi)                 |
| Time Dependent Dielectric Breakdown  | Dielectric layers  | V, T  | Arrhenius (Fowler-Nordheim)         |

$\Delta$ : Cyclic range  
 $\Lambda$ : gradient  
 T: Temperature  
 H: Humidity

V: Voltage  
 M: Moisture  
 J: Current density  
 $\sigma$ : Stress

# ESD/EOS Induced IC Failure Modes and Sites

Electrostatic discharge (ESD)/Electrical overstress (EOS) damage to an electrical circuit occurs due to electrical or thermal overstress during a transient electrical pulse.

Electrically, ESD and EOS can manifest as

- Opens
- Shorts
- Increased leakage
- Parametric shift

Physically, ESD and EOS can cause

- Melted bonding wires
- Molding compound burning
- Junction failure
- Gate oxide breakdown
- Discoloration
- Contact spike

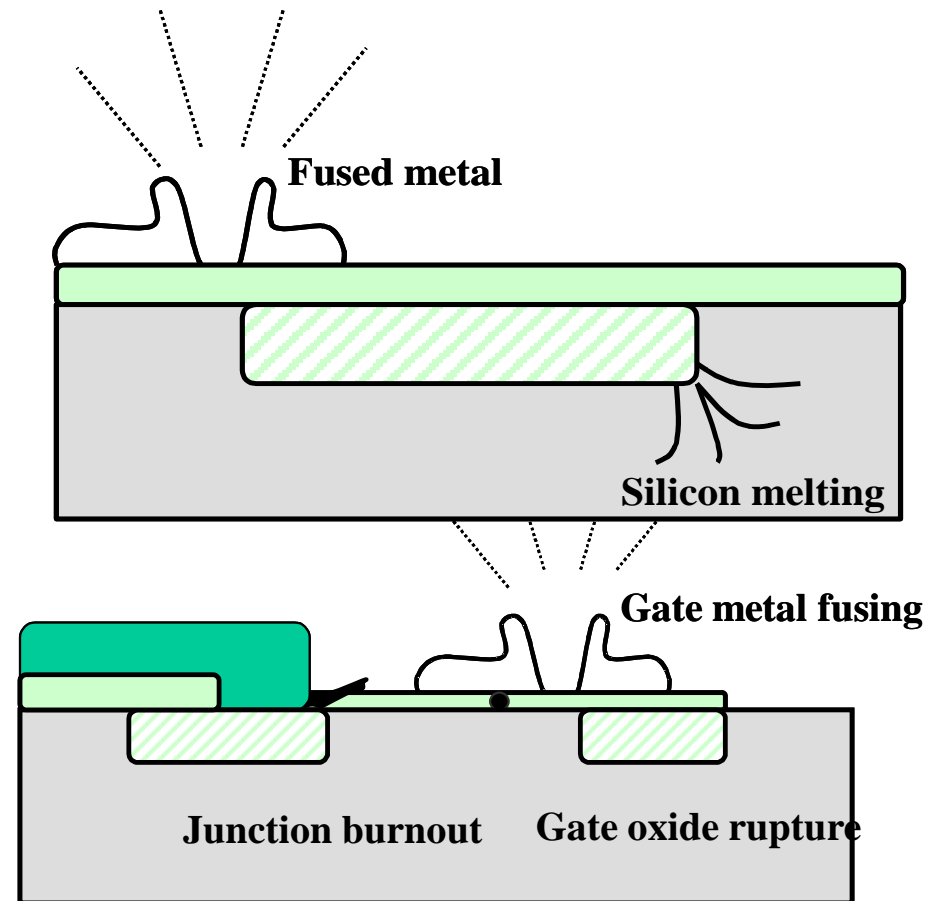

# Board Level Failures (examples)

## Plated Through Hole (PTH)/Via

1. Fatigue cracks in PTH/Via wall
2. Overstress cracks in PTH/Via wall
3. Land corner cracks
4. Openings in PTH/Via wall
5. PTH/Via wall-pad separation

## Electrical

6. Electrical overstress (EOS)
7. Signal interruption (EMI)

## Board

8. CAF (hollow fiber)
9. CAF (fiber/resin interface)
10. Electrochemical migration
11. Buckling (warp and twist)

## Copper Metallization

12. Cracks in internal trace
13. Cracks in surface trace
14. Corrosion of surface trace

# Assembly Level Failures (examples)

## Solder Interconnect

- Poor Solderability/Wettability
  - Tombstoning; Can accelerate other solder failure mechanisms
- Overstress Interconnect Failures
  - Solder Fracture (accelerated by intermetallic formation)
- Wearout Interconnect Failures
  - Solder Fatigue, Solder Creep
- Solder Bridging
- Component Failure due to Handling

# ECM: Surface and Sub-surface Mechanisms

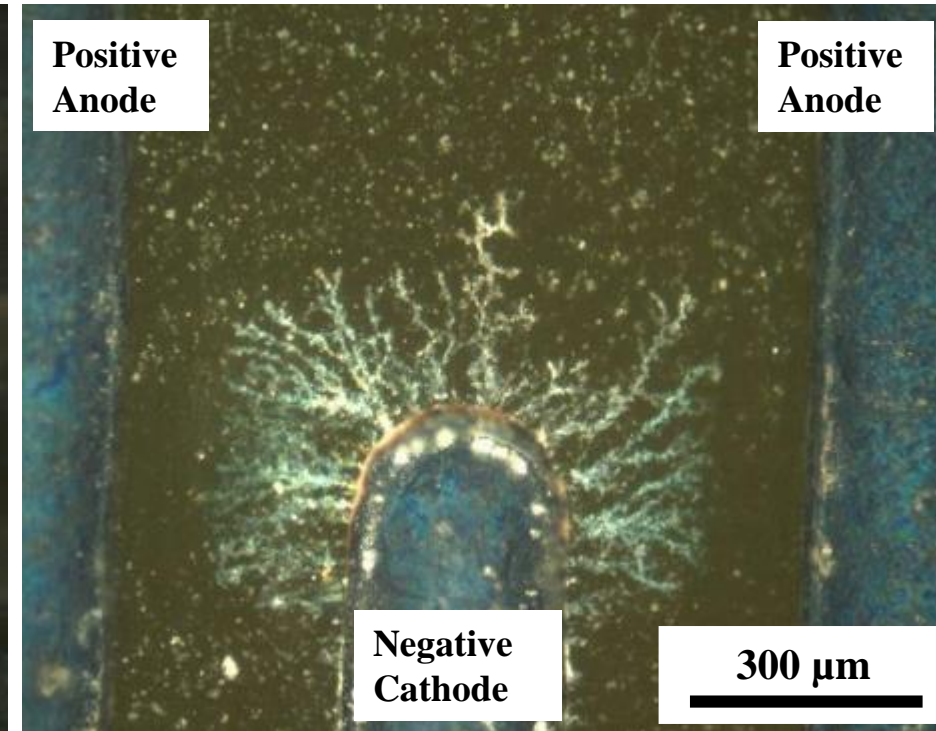
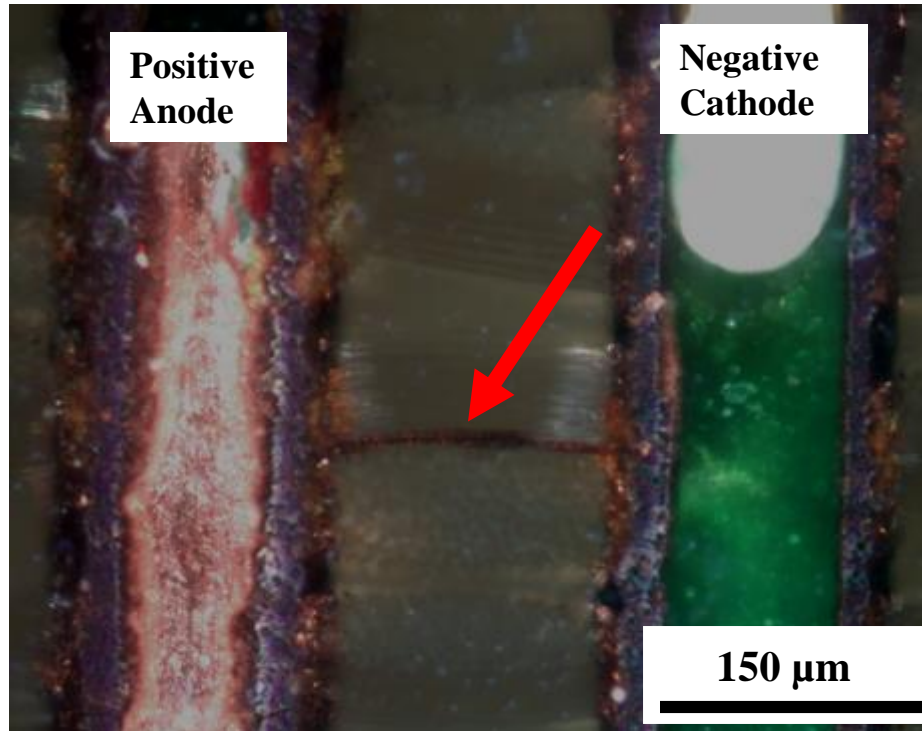

| ECM                         | Conductive Anodic Filament (CAF) | Dendritic Growth |
|-----------------------------|----------------------------------|------------------|
| <b>Growth Direction</b>     | Anode to cathode                 | Cathode to anode |
| <b>Filament Composition</b> | Metallic salt                    | Pure metal       |
| <b>Growth Position</b>      | Internal                         | Surface          |

Ref: Sood, Bhanu, Michael Osterman, and Michael Pecht. "An Examination of Glass-fiber and Epoxy Interface Degradation in Printed Circuit Boards." and Zhan, Sheng, Michael H. Azarian, and Michael Pecht. "Reliability of printed circuit boards processed using no-clean flux technology in temperature-humidity-bias conditions." *Device and Materials Reliability, IEEE Transactions on 8.2 (2008): 426-434.*

# Formation of Conductive Filaments [1] [2]

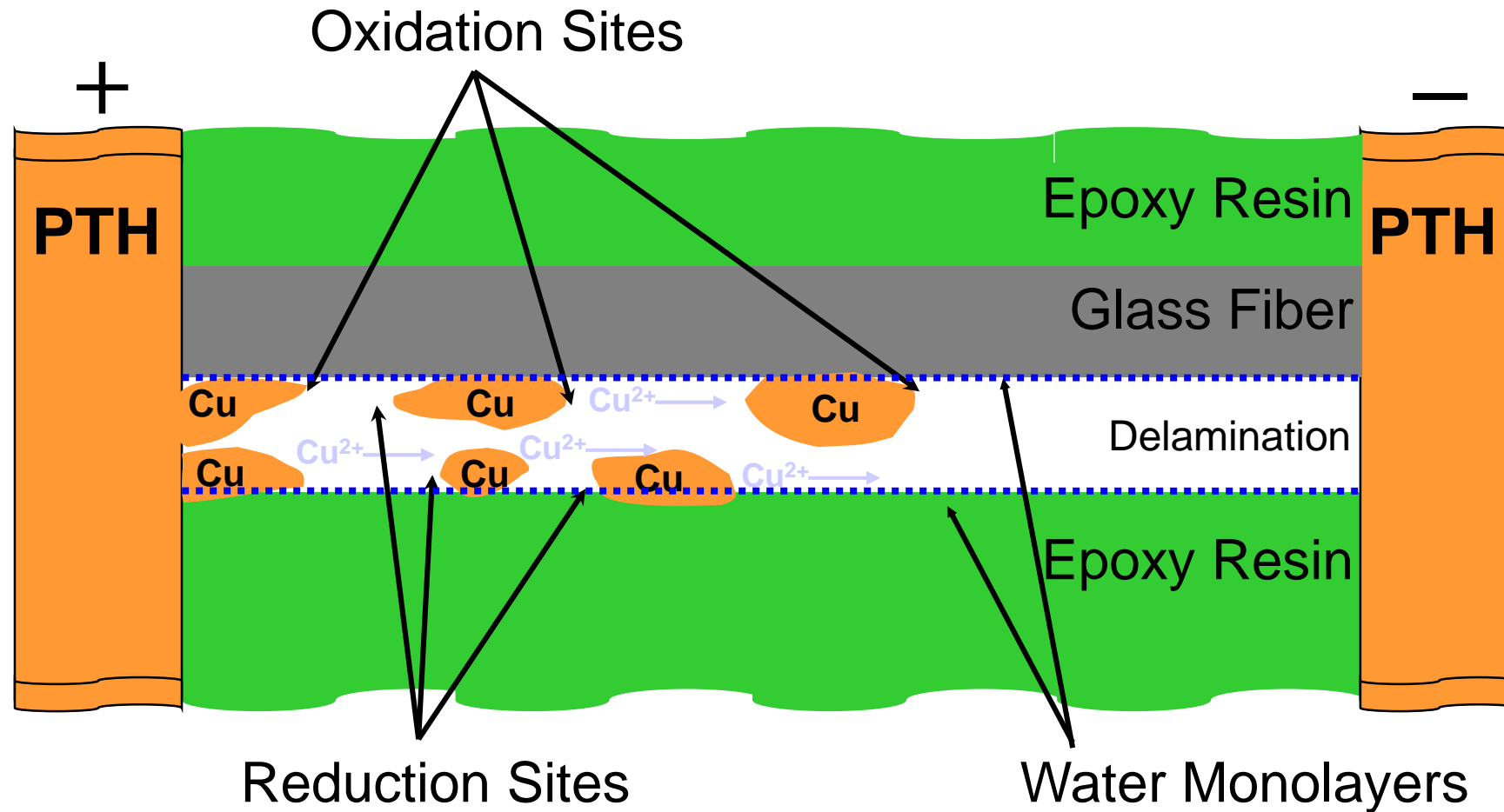

**A two step process:  $t_{\text{failure}} = t_1 + t_2$   $t_1 \gg t_2$**

1. Rogers, K. L. (2005). *An analytical and experimental investigation of filament formation in glass/epoxy composites* (Doctoral dissertation).
2. Sood, B., & Pecht, M. (2011). *Conductive filament formation in printed circuit boards: effects of reflow conditions and flame retardants*. *Journal of Materials Science: Materials in Electronics*, 22(10), 1602-1615.

# PTH-PTH (6 mil) 10V, 85° C/85% RH [1]

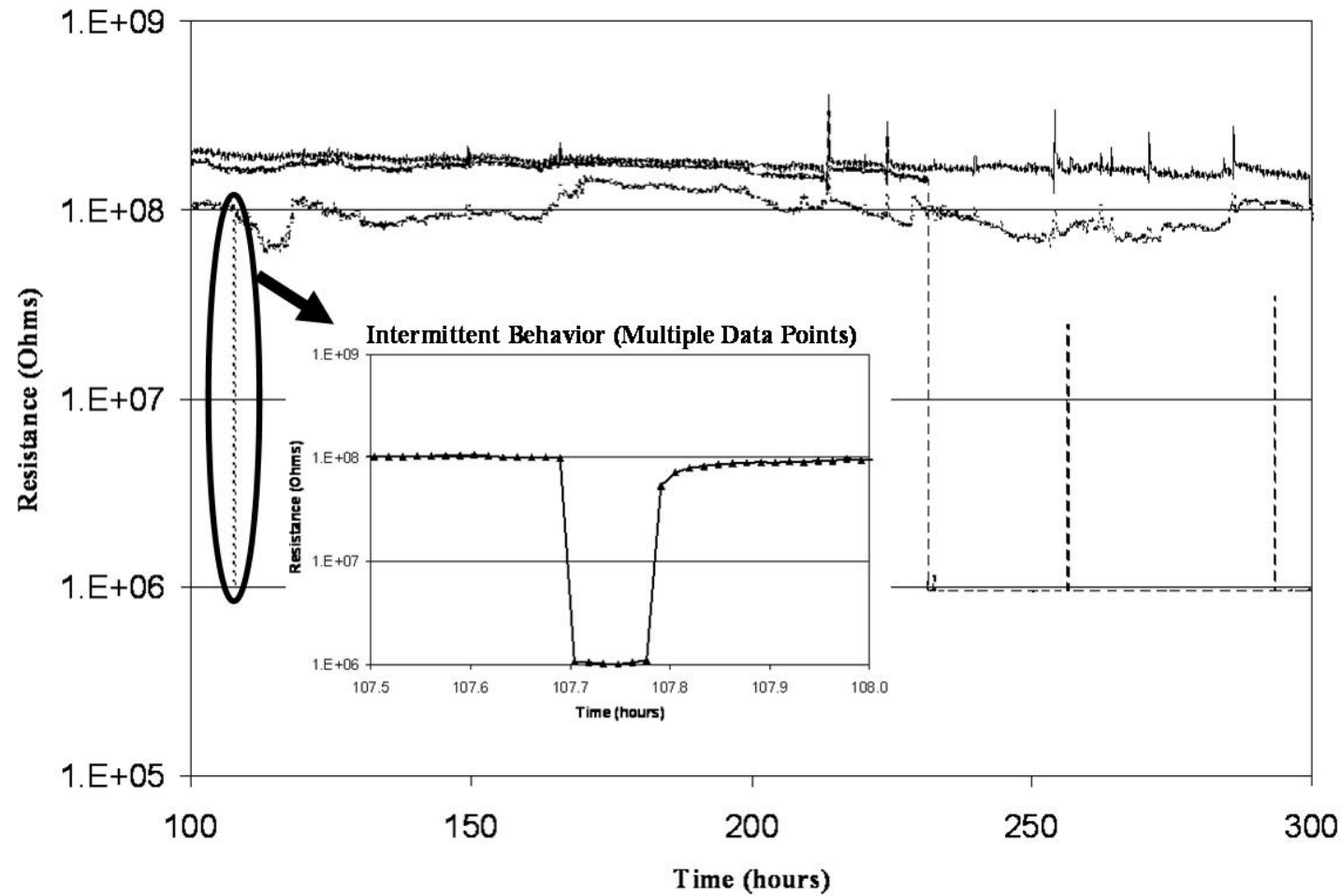

## Factors

- Voltage gradient
- Humidity
- Conductor spacing
- Ion concentration in epoxy resin

## Contributors

- Fiber/resin separation
- Thermal excursions
- Hollow fibers
- Wicking
- Drilling damage

[1] Sood, B., & Pecht, M. (2011). Conductive filament formation in printed circuit boards: effects of reflow conditions and flame retardants. *Journal of Materials Science: Materials in Electronics*, 22(10), 1602-1615.



# Importance of the Epoxy/Glass Interface [1] [2]

Path formation for CAF is often along the glass fiber to epoxy matrix interphase.

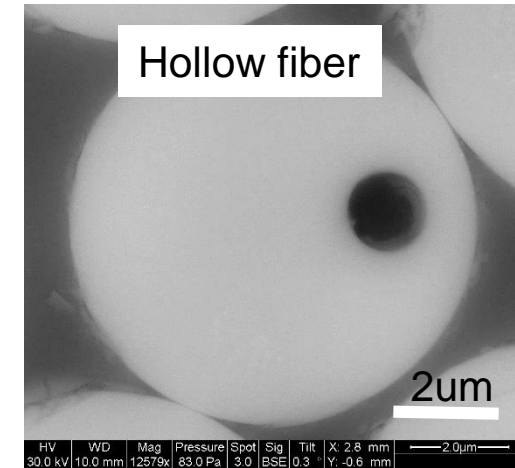
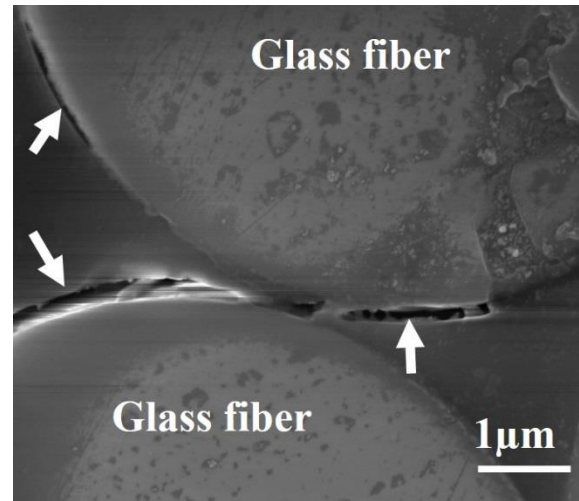
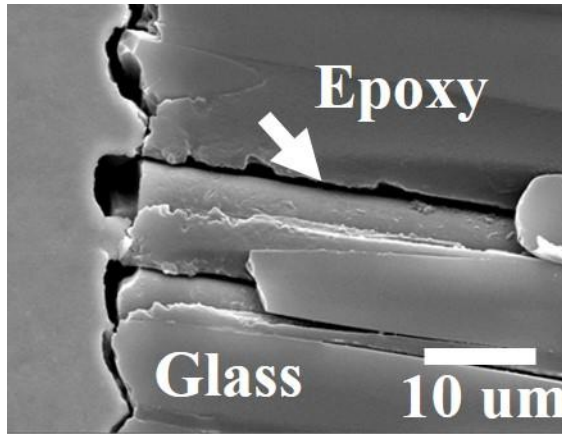

Path formation step ( $t_1$ ) for CAF is eliminated when hollow glass fibers are present.

Fiber/resin interphase delamination occurs due to CTE mismatch (shear) induced weakening or bond degradation.

[1] IPC-9691, User guide for the IPC-TM-650, method 2.6.25, conductive anodic filament (CAF) resistance and other internal electrochemical migration testing.

[2] Shukla, A. (1997). Hollow fibers in woven laminates. Print Circ Fab, 20(1), 30-32.

# CAF Paths

A. Between two plated-through holes (PTHs)

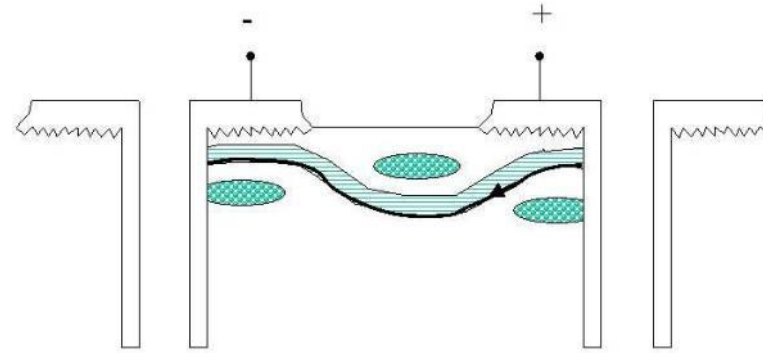

B. Between two traces

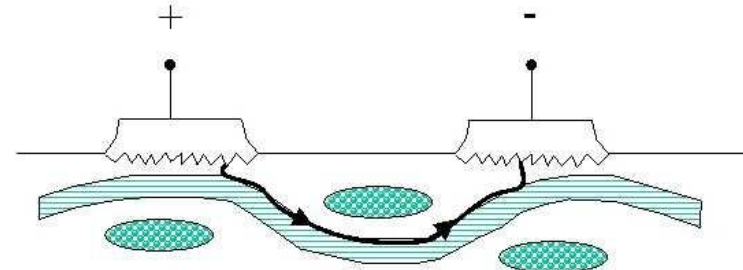

C. Between a trace and a plated-through hole (PTH)

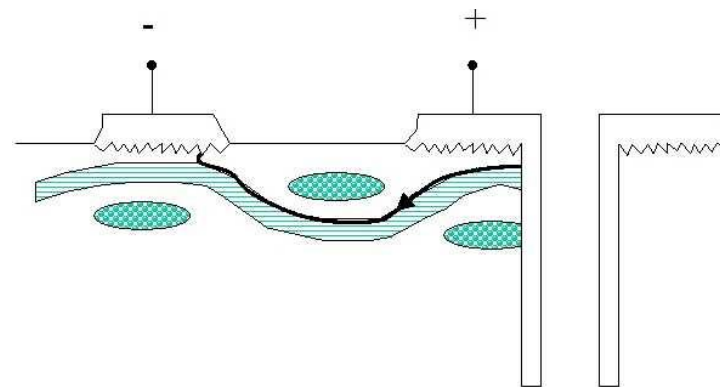

Ref: Rogers, Keith, et al. "Conductive filament formation failure in a printed circuit board." *Circuit World* 25.3 (1999): 6-8.

# Factors Affecting CAF: PCB Internal Conductor Spacings

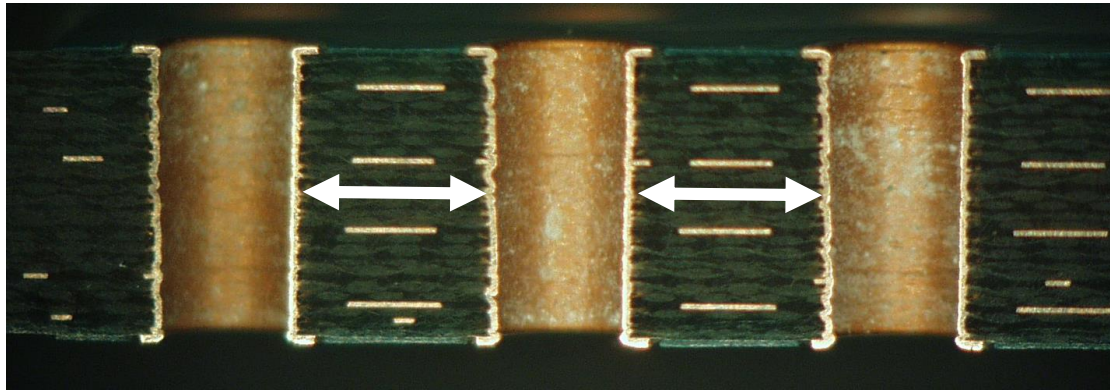

**PTH-to-PTH spacings**

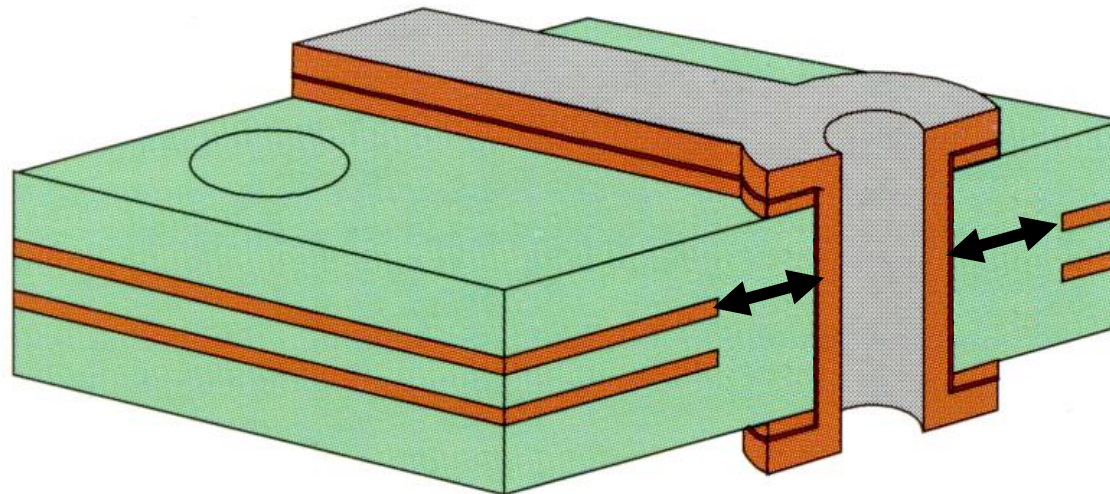

**PTH to plane spacings**

Ref: Rogers, Keith, et al. "Conductive filament formation failure in a printed circuit board." *Circuit World* 25.3 (1999): 6-8.

# Factors Affecting CAF: Board Orientation Respective to Fabric Weave

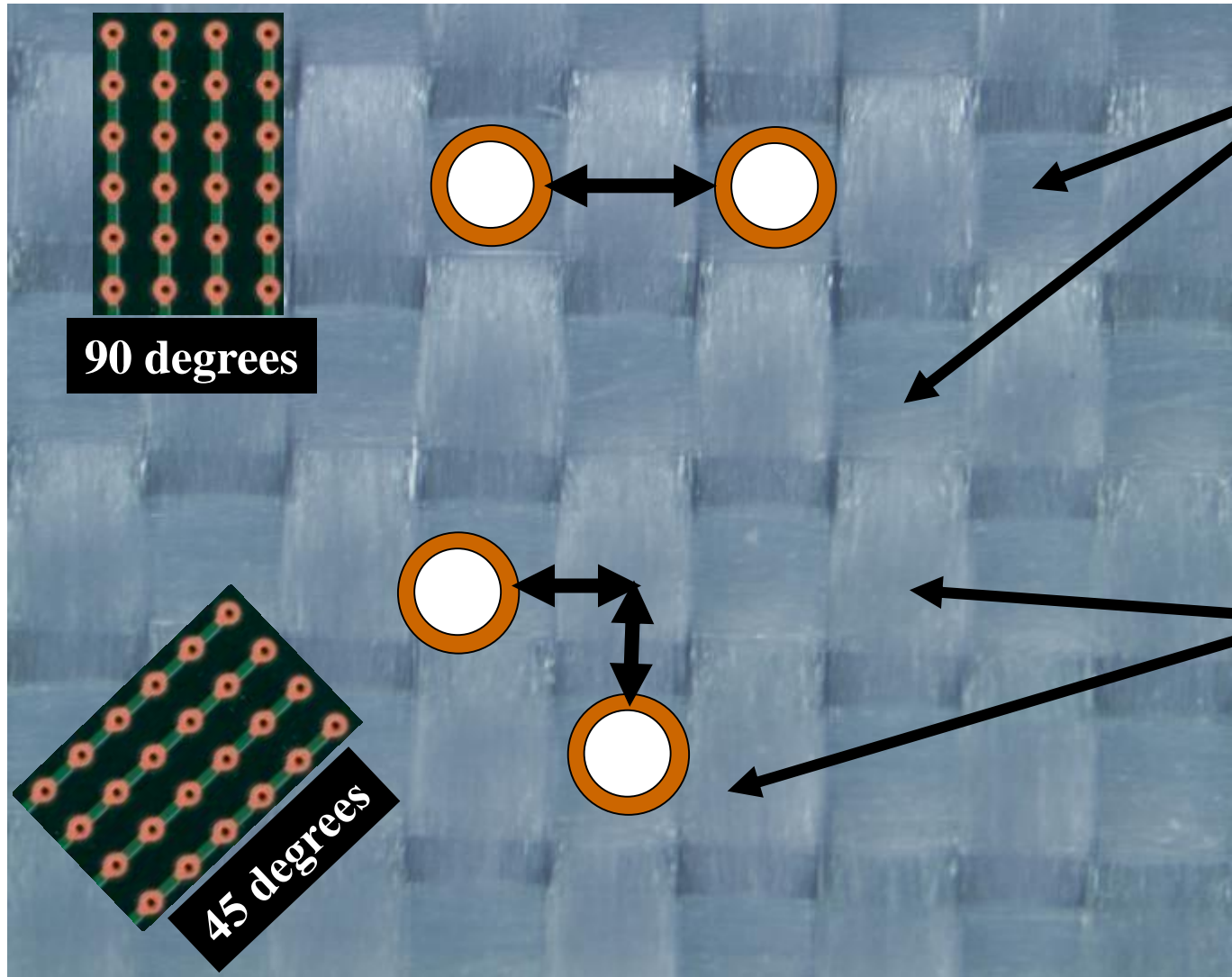

The initial set of parallel fiber bundles, known as the warp, lie in the machine direction

A second set of parallel fiber bundles, known as the fill or weft, is woven through the first set

*Ref: Rogers, Keith Leslie. "An analytical and experimental investigation of filament formation in glass/epoxy composites." (2005).*

# Effect of Voltage and Humidity on Time to Failure

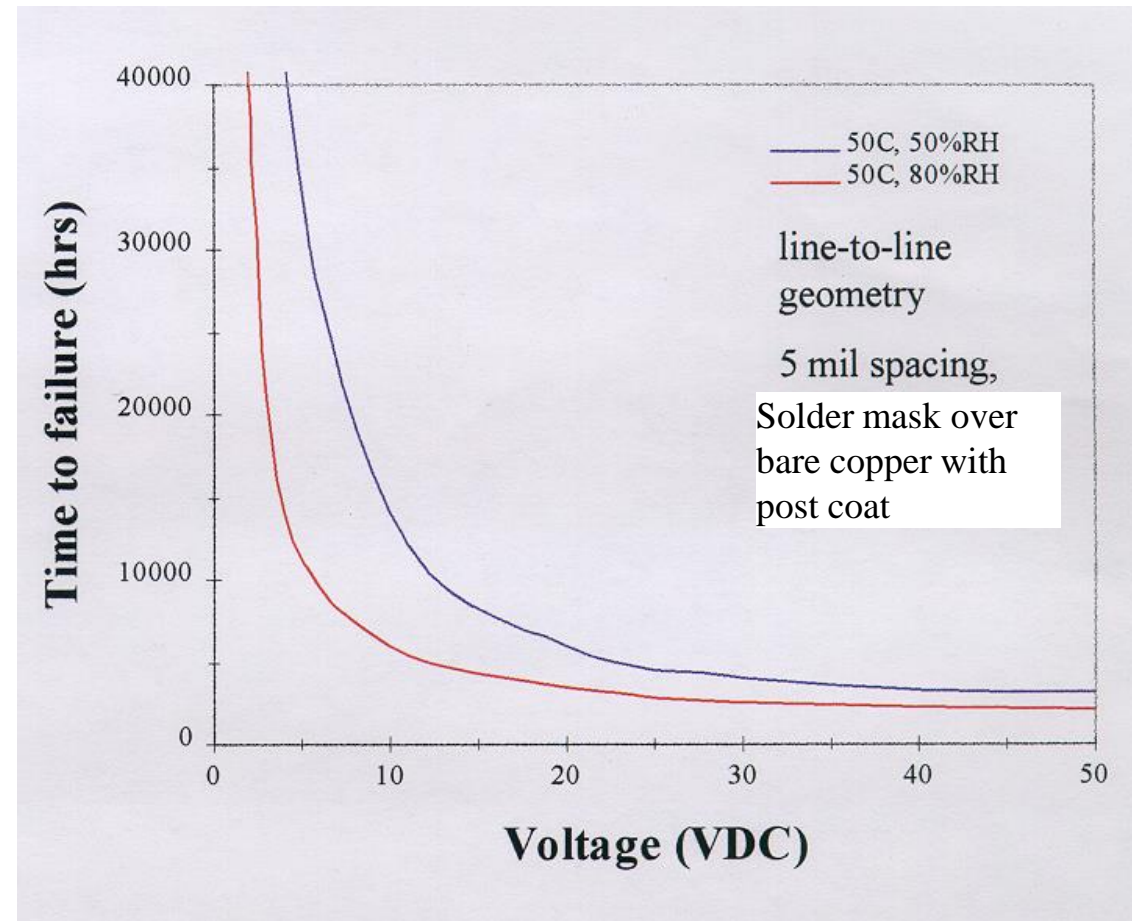

Ref: Rogers, Keith Leslie. "An analytical and experimental investigation of filament formation in glass/epoxy composites." (2005).

# Fiber/Resin Interface Delamination

*Fiber/resin interface delamination occurs as a result of stresses generated under thermal cycling due to a large CTE mismatch between the glass fiber and the epoxy resin (ratio of 1 to 12).*

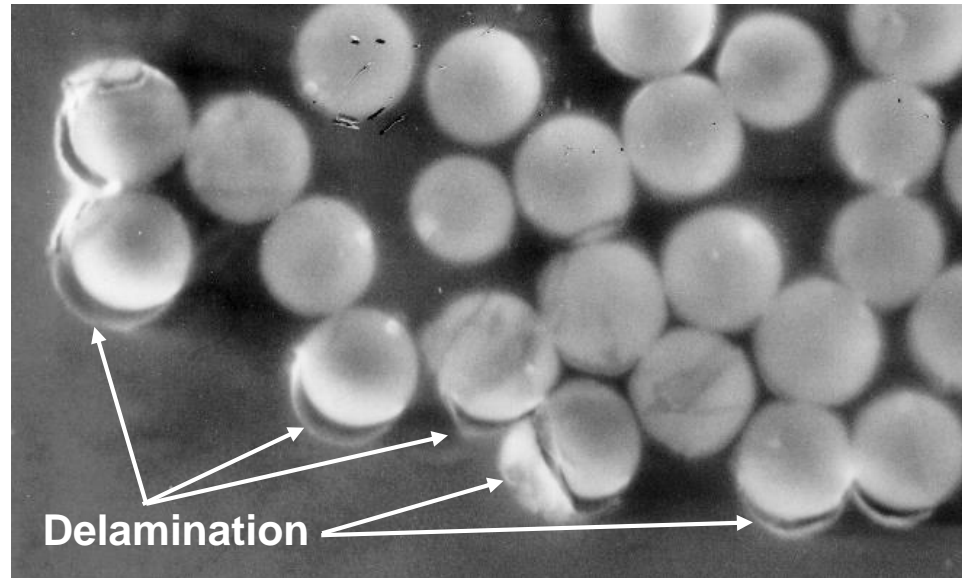

Delamination can be prevented/resisted by selecting resin with lower CTE's and optimizing the glass surface finish. Studies have shown that the bond between fiber and resin is strongly dependent upon the fiber finish.

*Ref: Rogers, Keith Leslie. "An analytical and experimental investigation of filament formation in glass/epoxy composites." (2005).*

# Hollow Fibers

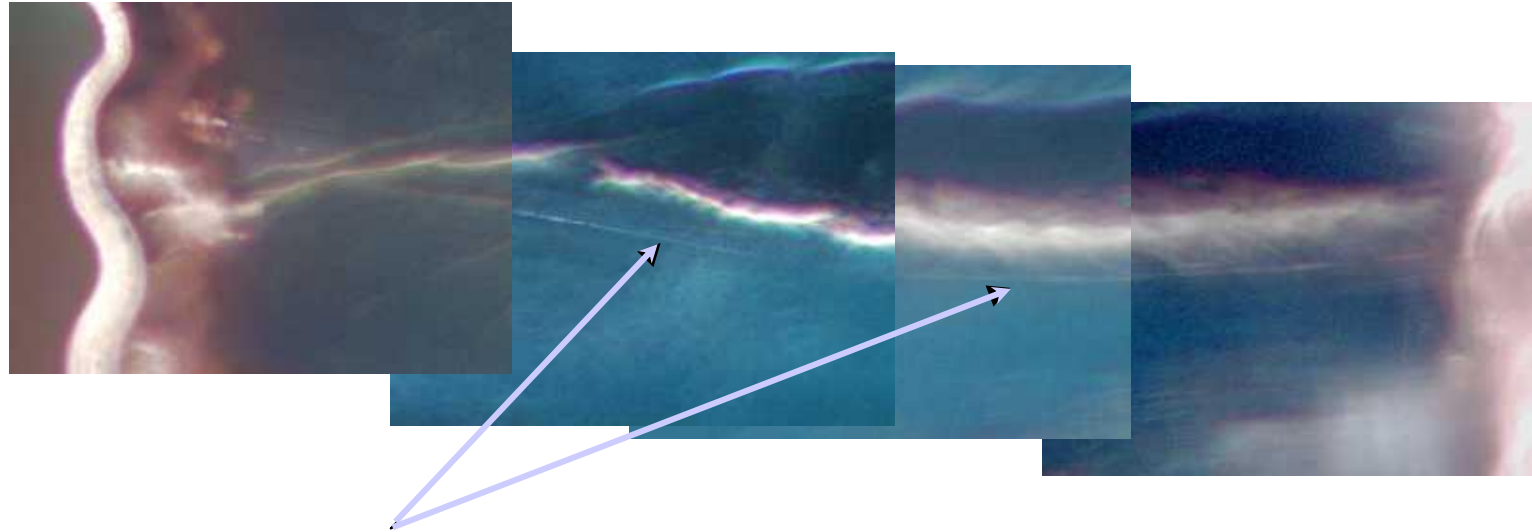

Hollow fibers are vacuous glass filaments in E-glass laminates that can provide paths for CAF.

With the appearance of hollow fibers inside the laminates, CAF can happen as a one step process. In this case, the number of hollow fibers inside the laminates is most critical to reliability.

*Ref: Rogers, Keith Leslie. "An analytical and experimental investigation of filament formation in glass/epoxy composites." (2005).*

# Images of Hollow Fibers

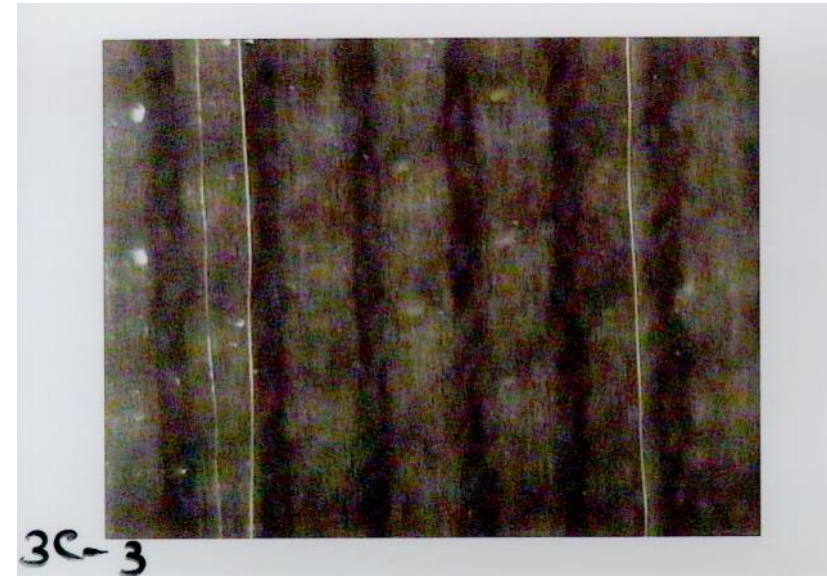
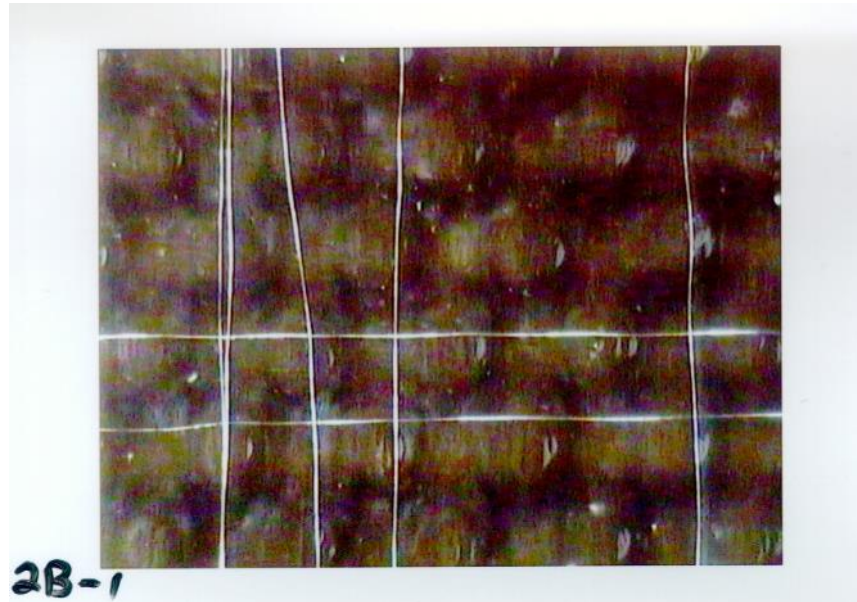

Ref: Rogers, Keith Leslie. "An analytical and experimental investigation of filament formation in glass/epoxy composites." (2005).



# Drilling

Drilling damage can accelerate CAF through

- Fiber/resin delamination,
- Creation of paths for moisture to accumulate
- Wicking due to cracking of the board material

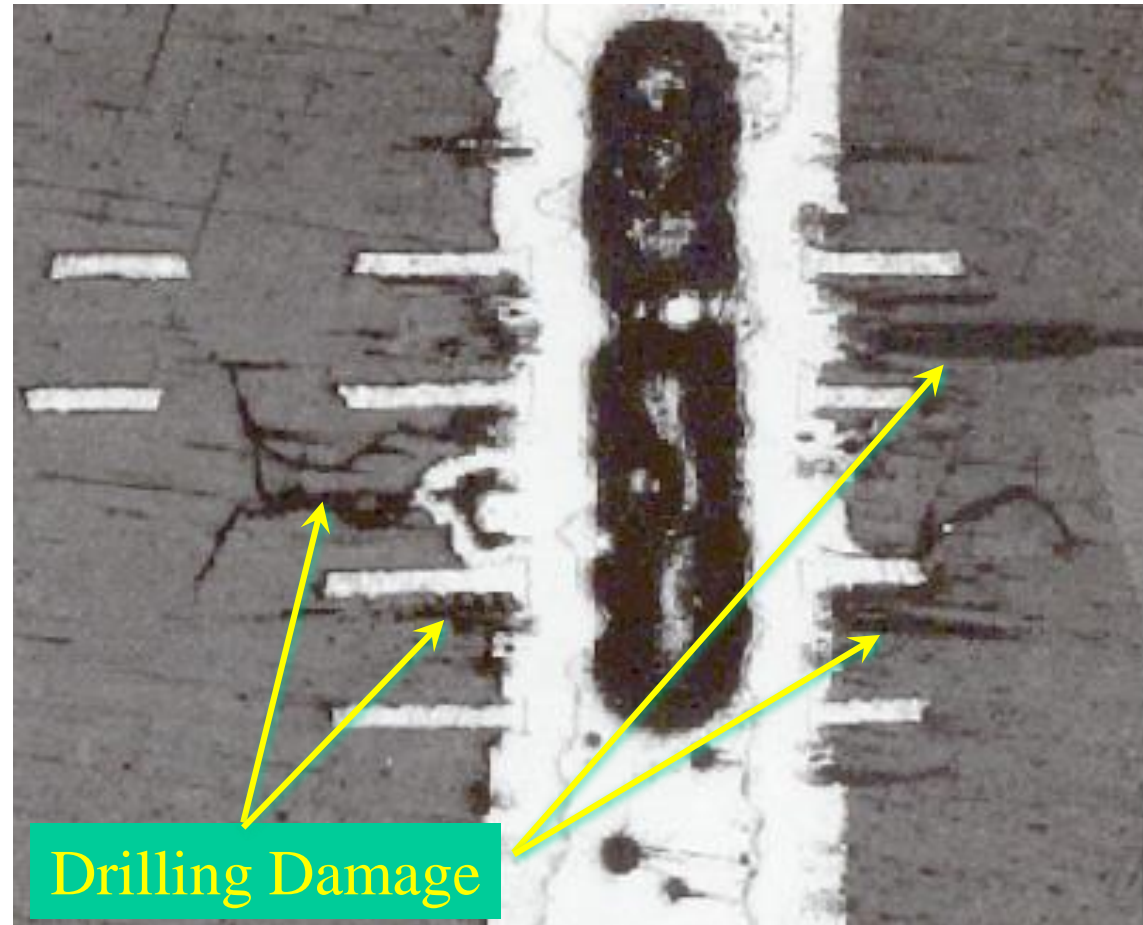

*Ref: Rogers, Keith Leslie. "An analytical and experimental investigation of filament formation in glass/epoxy composites." (2005).*

# PTH-Resin Separation

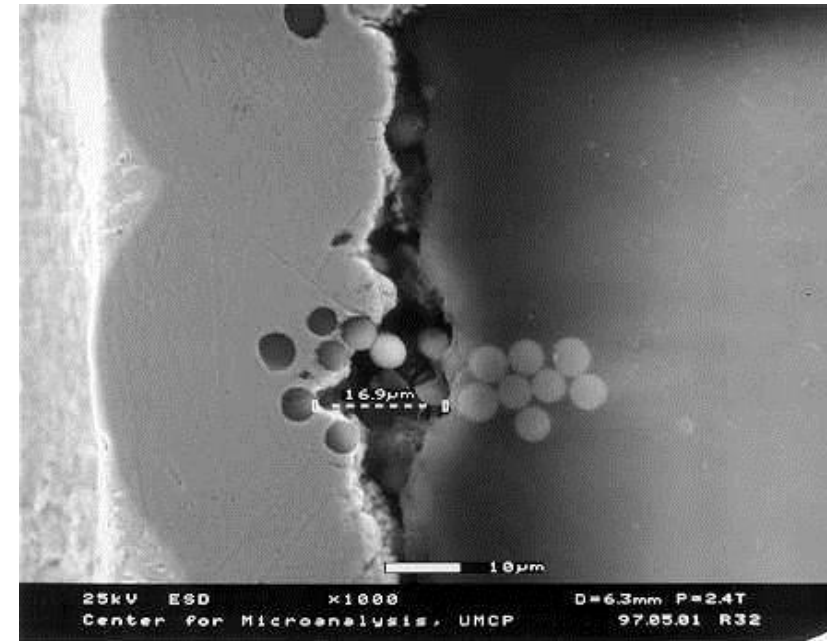
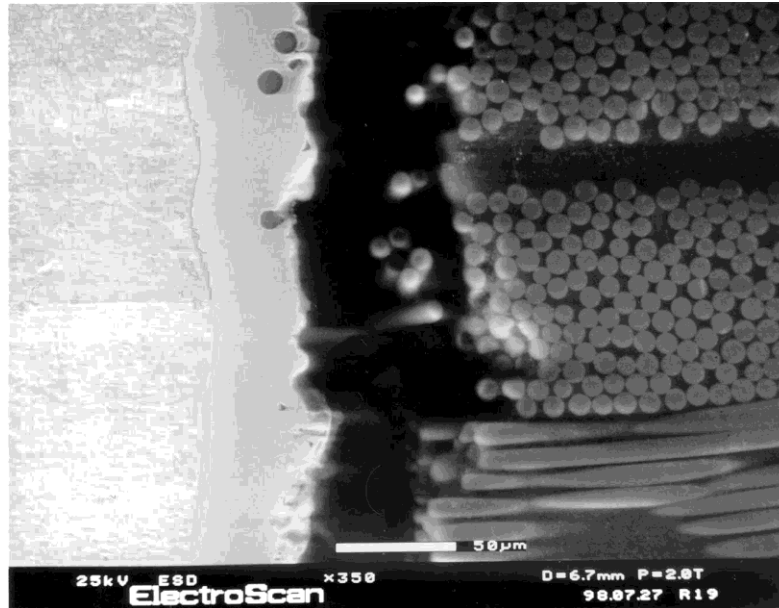

In both of these SEM pictures, a separation can be seen at the copper plating to fiber epoxy resin board interface. These gaps provide an accessible path for moisture to accumulate and CAF to initiate. These voids can be adjacent to inner-layer copper foil or to the PTH barrel and normally result from contraction of the epoxy (resin recession) due to the heat of thermal stress.

*Ref: Rogers, Keith Leslie. "An analytical and experimental investigation of filament formation in glass/epoxy composites." (2005).*

# Background on Dendritic Growth

**Dendritic Growth** is a form of electrochemical migration (ECM) involving the growth of conductive filaments on or in a printed circuit board (PCB) under the influence of a DC voltage bias. [IPC-TR-476A]

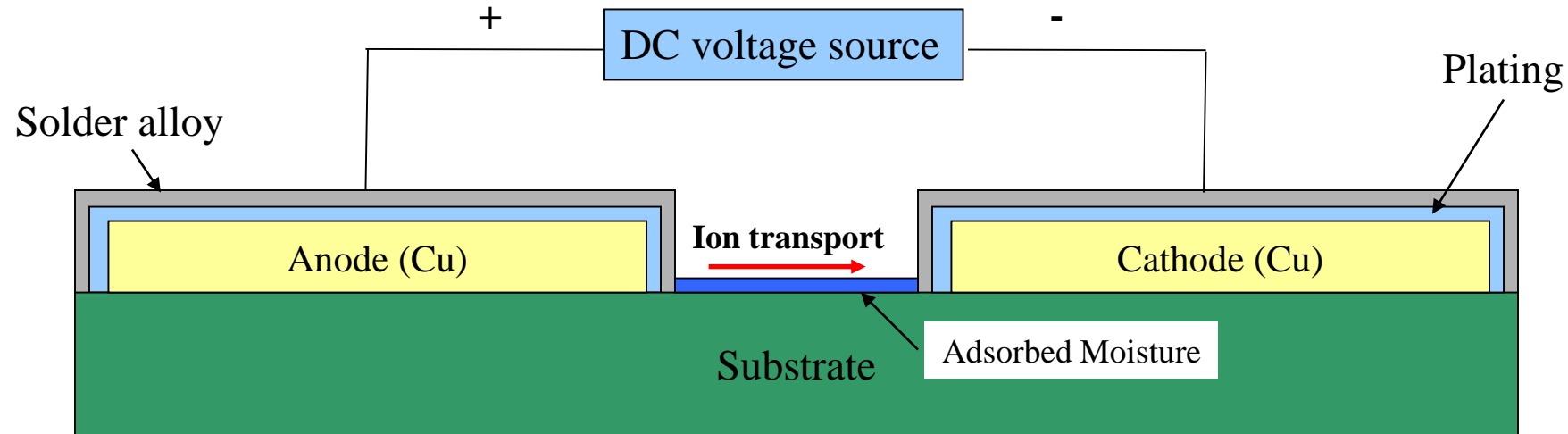

## Necessary Conditions for ECM

- Electrical carriers (ions).
- A medium, usually water, to dissolve the ionic materials and sustain them in their mobile ionic state.
- Electrical potential between the electrodes to establish an ionic current in the liquid medium.

## Stages of ECM

- Path formation
- Electrodesolution
- Ion transport
- Electrodeposition
- Filament growth

He, Xiaofei, M. Azarian, and M. Pecht. "Effects of solder mask on electrochemical migration of tin-lead and lead-free boards." *IPC printed circuit Expo, APEX & Designer summit proceedings.*

# Electrochemical Migration

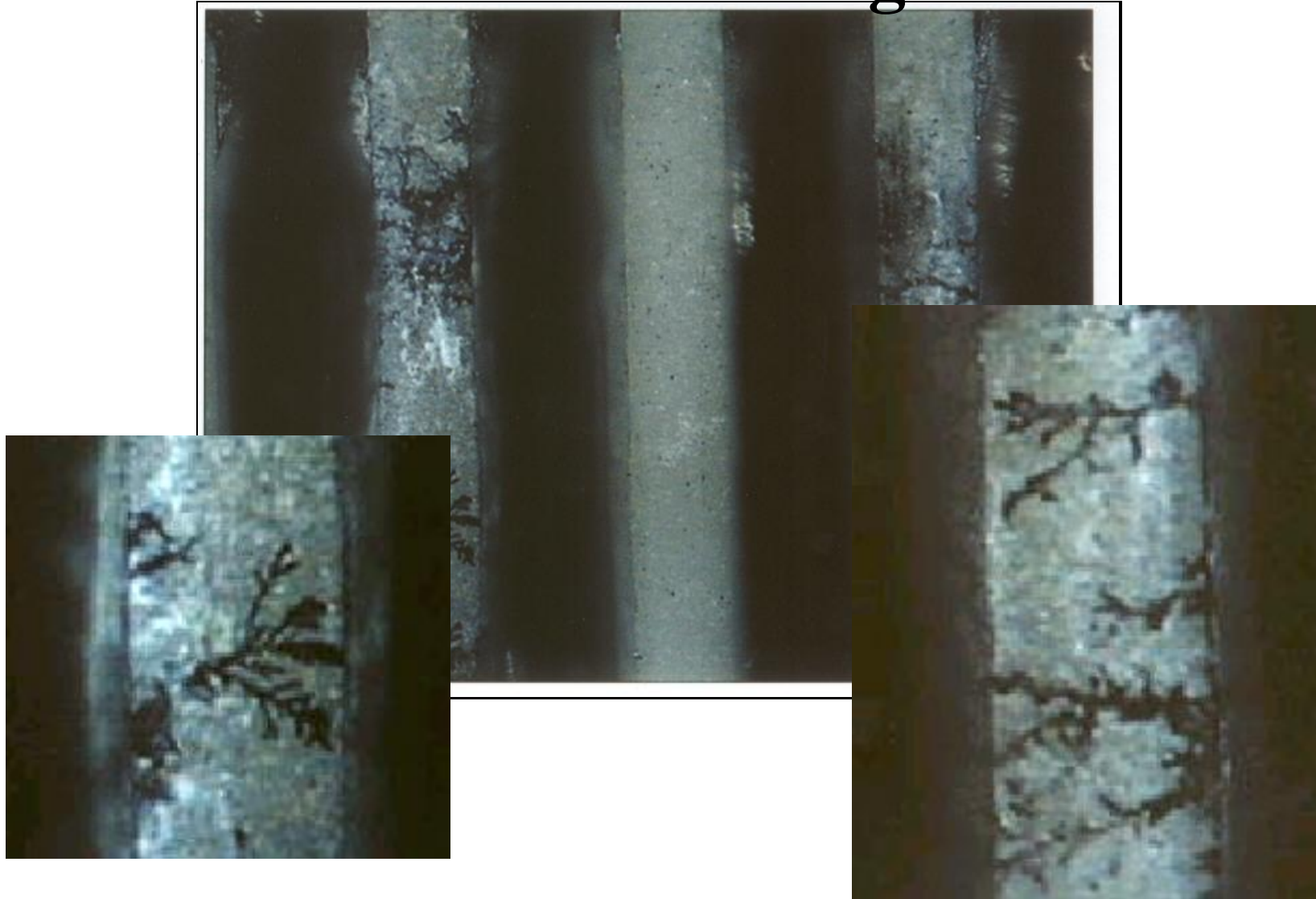

Ref: He, Xiaofei, M. Azarian, and M. Pecht. "Effects of solder mask on electrochemical migration of tin-lead and lead-free boards." IPC printed circuit Expo, APEX & Designer summit proceedings and Ambat, Rajan, et al. "Solder flux residues and electrochemical migration failures of electronic devices." Eurocorr proceedings, Nice 10.1.3321953 (2009).

# Contaminants

- Halide residues, such as chlorides and bromides, are the most common accelerators of dendritic growth.
- Chlorides are more detrimental, but easier to clean
- Bromides can resist cleaning; often require DI water with saponifier
- In general, an increased risk of ECM will tend to occur once the levels of chloride exceed  $10\mu\text{g}/\text{in}^2$  or bromide exceeds  $15\mu\text{g}/\text{in}^2$
- Rapid failure can occur when contaminant levels exceed  $50\mu\text{g}/\text{in}^2$

*Ref: He, Xiaofei, M. Azarian, and M. Pecht. "Effects of solder mask on electrochemical migration of tin-lead and lead-free boards." IPC printed circuit Expo, APEX & Designer summit proceedings and Ambat, Rajan, et al. "Solder flux residues and electrochemical migration failures of electronic devices." Eurocorr proceedings, Nice 10.1.3321953 (2009).*

# What Are the Sources of Contaminants?

- Board Manufacturing
  - Flame-proofing agents
  - Copper plating deposits
  - Etchants
  - Cleaners
  - Fluxes (for HASL coatings)
  - Poorly polymerized solder masks
  - “Fingerprints”
- Assembly
  - Fluxes
  - Solder paste residues
  - “Fingerprints”
- Environmental
  - Liquid (i.e., salt spray)
  - Gaseous (i.e., Cl<sub>2</sub>)

*Ref: He, Xiaofei, M. Azarian, and M. Pecht. "Effects of solder mask on electrochemical migration of tin-lead and lead-free boards." IPC printed circuit Expo, APEX & Designer summit proceedings and Ambat, Rajan, et al. "Solder flux residues and electrochemical migration failures of electronic devices." Eurocorr proceedings, Nice 10.1.3321953 (2009).*

# Plated Through Hole (PTH) Failures

1. Circumferential cracking
  - Single event overstress
  - Cyclic fatigue
2. Openings (voids, etch pits)
  - Accelerate circumferential cracking
3. Wall-Pad Separation
  - Also known as “breakout of internal lands” or “plated-barrel separation”

# PTH Failures (cont.)

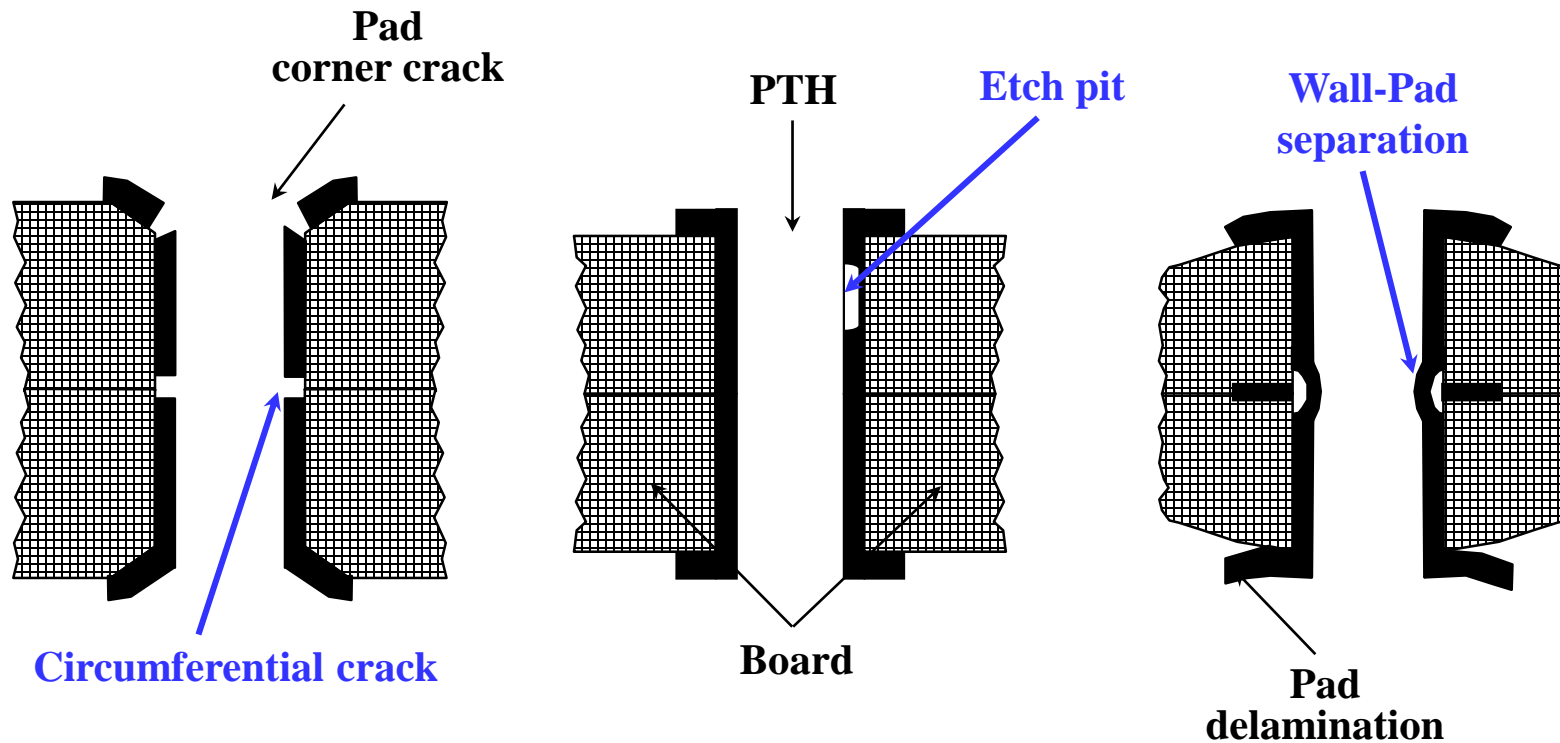

Ref: Bhandarkar, S. M., et al. "Influence of selected design variables on thermo-mechanical stress distributions in plated-through-hole structures." *Journal of Electronic Packaging* 114.1 (1992): 8-13.



# 1. Circumferential Cracking – Single Event Overstress

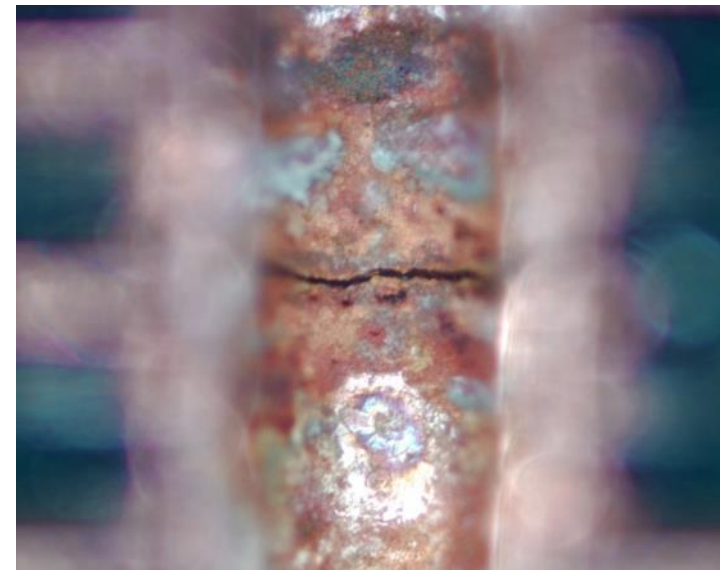
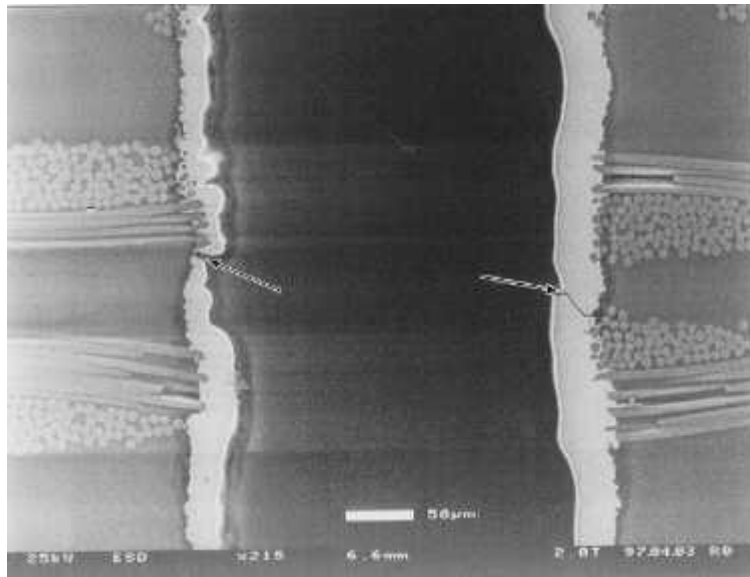

Since the difference in the coefficient of thermal expansion (CTE) of the copper plating and the resin system in the PWBs is at least a factor of 13, stress exerted on the plated copper in the plated-through holes in the z-axis can cause cracking.

*Ref: Bhandarkar, S. M., et al. "Influence of selected design variables on thermo-mechanical stress distributions in plated-through-hole structures." Journal of Electronic Packaging 114.1 (1992): 8-13.*

# Single Event Overstress (cont.)

- Failure Mode
  - Complete electrical open
- Failure History
  - Primarily occurs during assembly; may not be detected until after operation
- Root-Causes
  - Excessive temperatures during assembly
  - Resin Tg below specification
  - Insufficient curing of resin
  - Outgassing of absorbed moisture
  - Plating folds
  - PTH wall recession
  - Resin-rich pockets adjacent to PTH
  - Insufficient mechanical properties of deposited copper
  - Plating voids
  - Etch pits
  - Insufficient PTH wall thickness

# Design Considerations to Avoid Fatigue Damage in PTHs

- PTH Spacing
  - Decreasing spacing improves mechanical reliability
- Aspect Ratio
  - Decreasing board thickness more effective than increasing hole diameter
- Plating Thickness
  - Increasing leads to increasing in fatigue strength
- Nonfunctional Internal Pads
  - Minimal effect. Results in localized stress relief; most effective when results in elimination of resin-rich areas

*Ref: Kapur, Kailash C., and Michael Pecht. Reliability engineering. John Wiley & Sons, 2014.*

# Root-Cause Analysis of Circumferential Fatigue Cracking

- Failure Mode
  - Intermittent to complete electrical open
- Failure History
  - Requires an environment with temperature cycling; often occurs after extended use in the field (“child” or “teenage” mortality)
- Root-Causes
  - Resin CTE below specification
  - Plating folds
  - PTH wall recession
  - Resin-rich pockets adjacent to PTH
  - Customer use exceeds expected environment
  - Insufficient mechanical properties of deposited copper
  - Presence of overstress crack
  - Plating voids
  - Etch pits (“mouse bites”)
  - Insufficient PTH wall thickness

## 2. Openings in PTH Walls

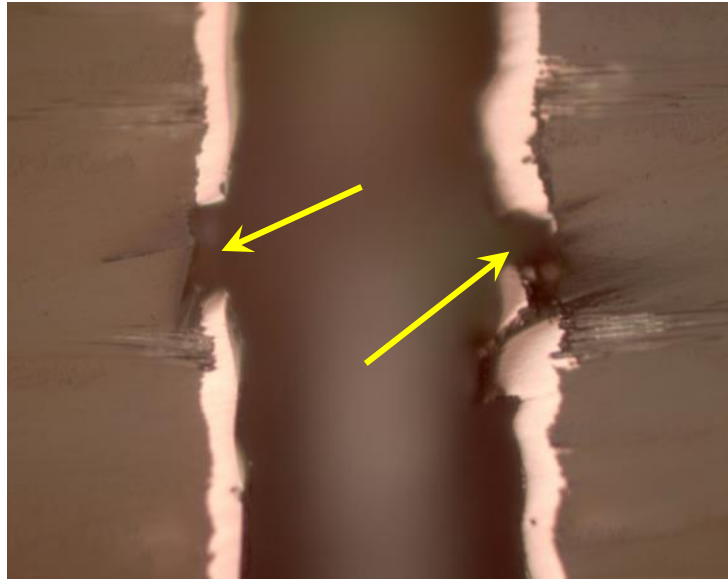

Optical micrograph of cross section of PTH with etch damage

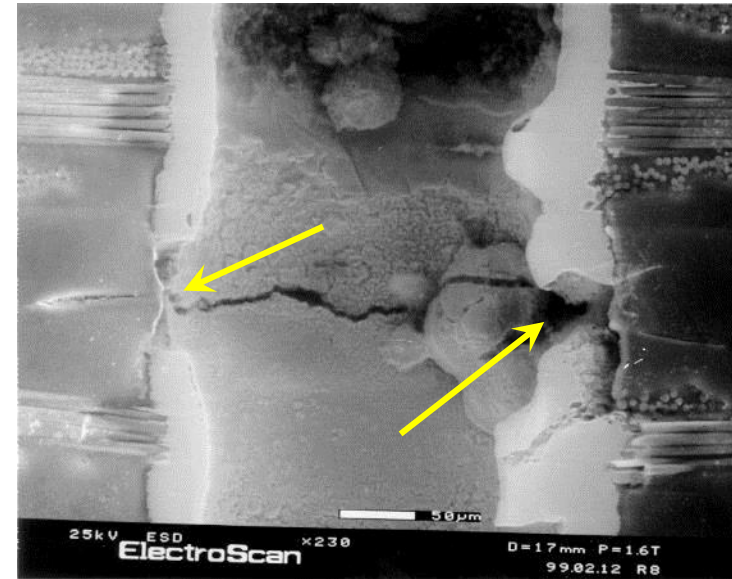

Electron micrograph of same PTH shown on left

*Overetching can cause electrical opens or induce overstress circumferential cracking*

Ref: Bhandarkar, S. M., et al. "Influence of selected design variables on thermo-mechanical stress distributions in plated-through-hole structures." *Journal of Electronic Packaging* 114.1 (1992): 8-13.

# Evidence of Overetching

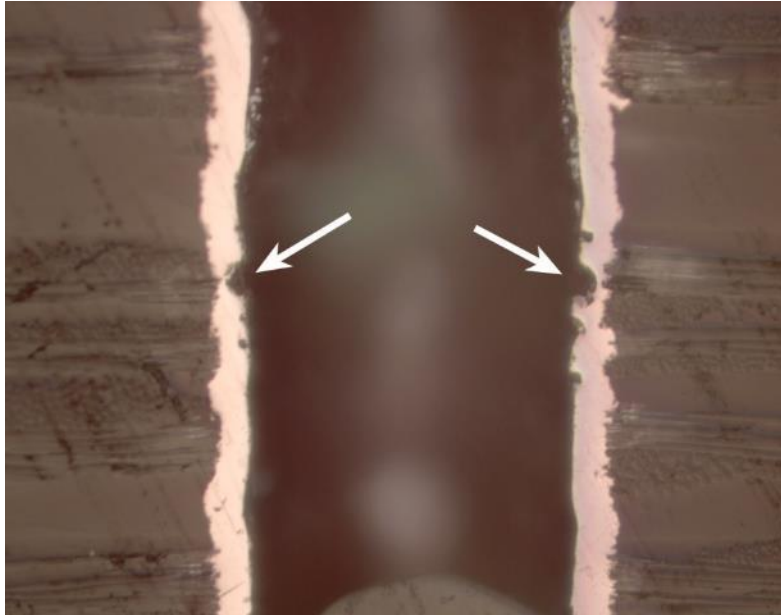

Optical micrograph of cross section of PTH with etch damage (bright field)



Optical micrograph of cross section of PTH with etch damage (dark field)

*Evidence of overetching can include reduced plating thickness and discoloration of PTH barrel walls*

**Ref: Bhandarkar, S. M., et al. "Influence of selected design variables on thermo-mechanical stress distributions in plated-through-hole structures." *Journal of Electronic Packaging* 114.1 (1992): 8-13.**

# Opening in PTH/Via

- Failure Mode
  - Complete electrical open
- Failure History
  - Often occurs during assembly; may not be detected until after operation
- Root-Causes
  - Openings in PTH's/Vias are etch pits or plating voids and often occur because the following manufacturing processes are not optimized:
    - Drilling
    - Desmear/Etchback
    - Electroless copper plating or direct metallization
    - Electrolytic copper plating
    - Tin resist deposition
    - Etching
  - Openings can also occur due to poor design (i.e., single-sided tenting of vias, resulting in entrapment of etchant chemicals)

*Ref: Bhandarkar, S. M., et al. "Influence of selected design variables on thermo-mechanical stress distributions in plated-through-hole structures." Journal of Electronic Packaging 114.1 (1992): 8-13.*

### 3. PTH/Via Wall-Pad Separation

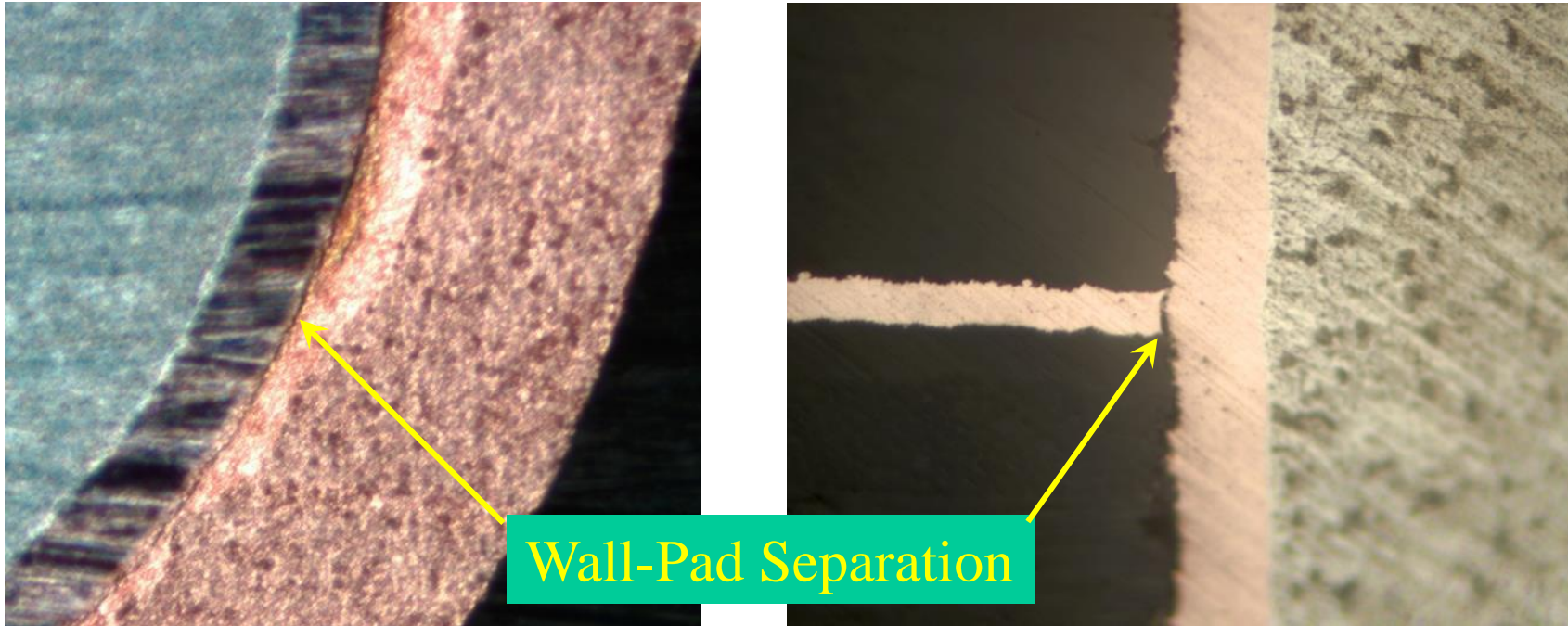

Optical micrograph of cross section perpendicular to the PTH axis

Optical micrograph of cross section parallel to the PTH axis

Ref: Bhandarkar, S. M., et al. "Influence of selected design variables on thermo-mechanical stress distributions in plated-through-hole structures." *Journal of Electronic Packaging* 114.1 (1992): 8-13.



# PTH/Via Wall-Pad Separation

- Failure Mode
  - Intermittent or complete electrical open
- Failure History
  - Will primarily only occur during assembly
- Root-Causes
  - Insufficient Curing of Resin.
  - Outgassing of absorbed moisture
  - Excessive temperatures during assembly
  - Resin CTE or Resin Tg below specification
  - Number of nonfunctional lands (only useful for failures during assembly)
  - Drilling process resulting in poor hole quality
  - Insufficient desmearing process.
  - Substandard processes or materials in electroless copper plating

*Ref: Bhandarkar, S. M., et al. "Influence of selected design variables on thermo-mechanical stress distributions in plated-through-hole structures." Journal of Electronic Packaging 114.1 (1992): 8-13.*

# Failure Mechanisms due to Handling

- Affects leadless components
  - Ball grid arrays (BGAs), Flip Chip on Board
- Affects brittle components
- Insidious
  - Failures due to handling tend to be difficult to screen and intermittent in nature
  - Often occur after testing

# When Do Handling Failures Occur?

- Assembly
  - Transfer of product between lines; during rework
- Heatsink Attachment
  - Use of screws
- Connector Insertion
  - Large press-fit connectors; daughter boards into mother boards
- Electrical Testing
  - Bed-of-Nails testing can bend local areas
- Packaging
- Transportation
- Customer Site
  - Slot insertion

# Evidence of Damage Due to Handling -- BGAs

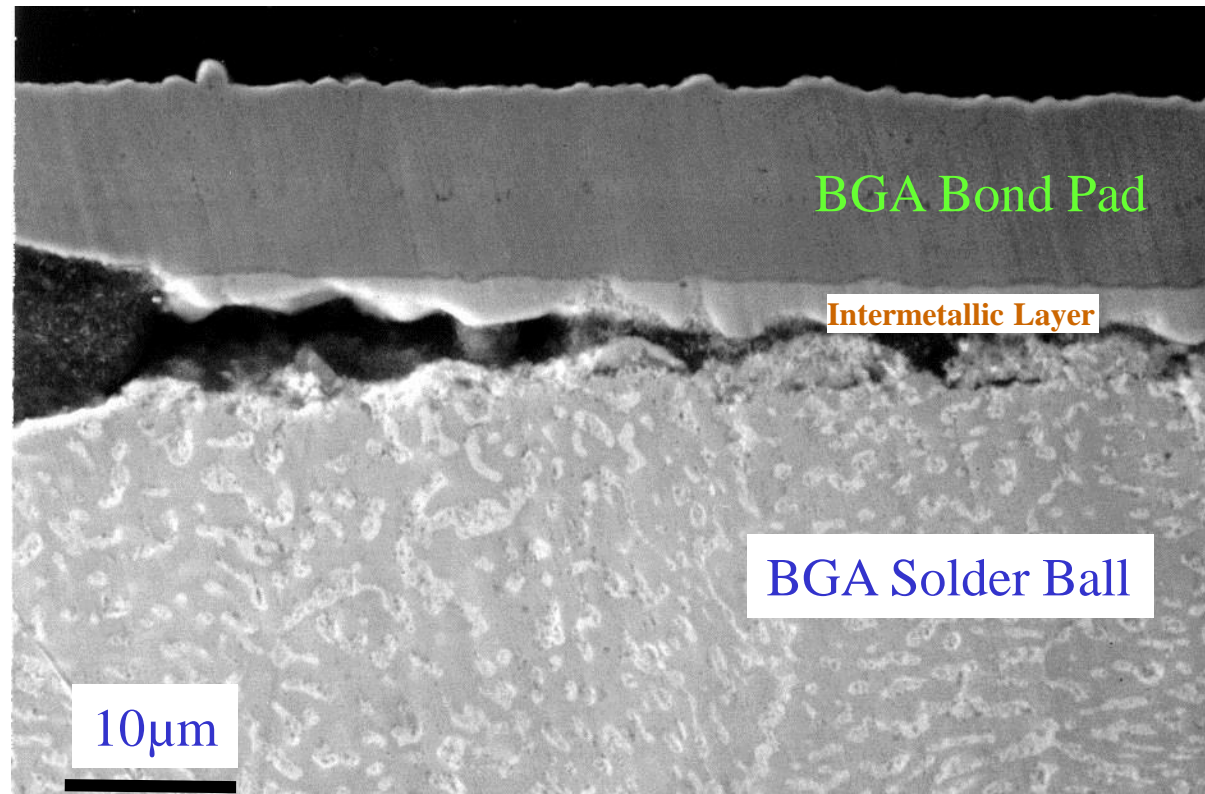

Ref: SEM Lab.

# Evidence of Damage – Ceramic Capacitors

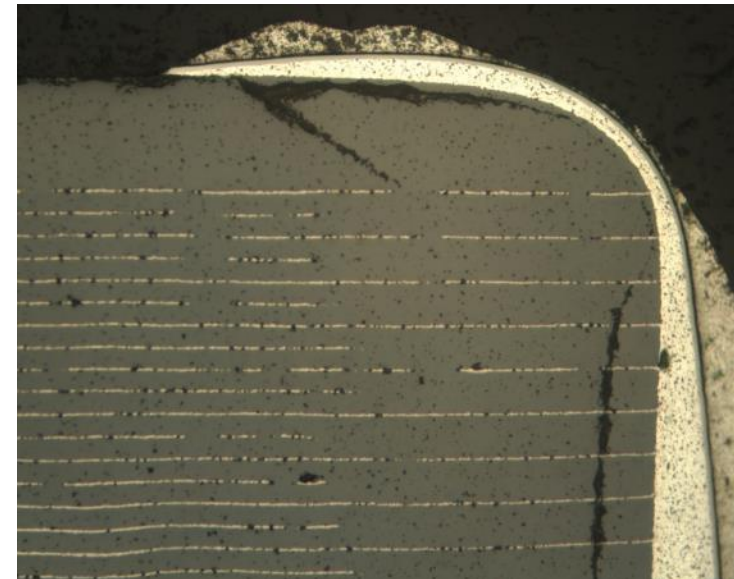
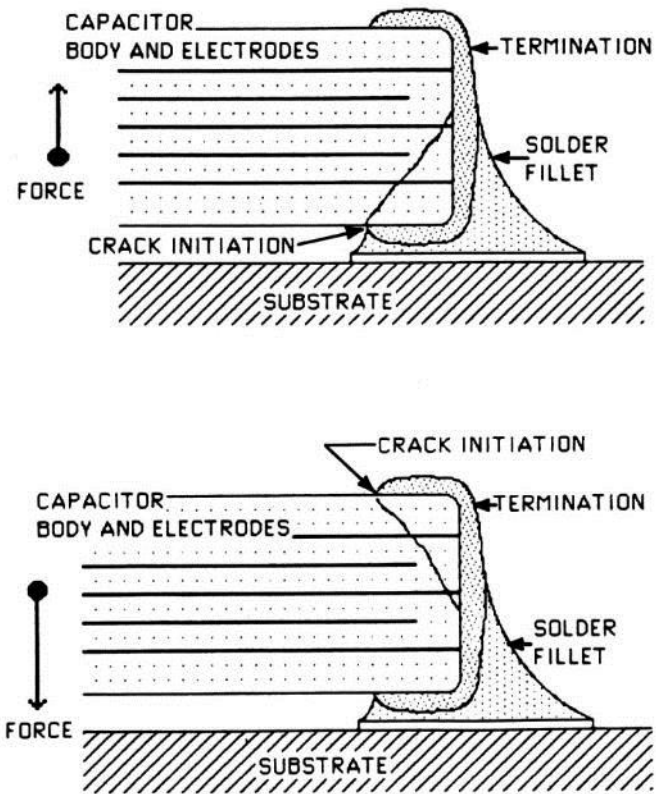

Keimasi, Mohammadreza, Michael H. Azarian, and Michael G. Pecht. "Flex Cracking of Multilayer Ceramic Capacitors Assembled With Pb-Free and Tin-Lead Solders." *Device and Materials Reliability, IEEE Transactions on* 8.1 (2008): 182-192.

# Intermittent Failures

- An intermittent failure is the loss of some function in a product for a limited period of time and subsequent recovery of the function.
- If the failure is intermittent, the product's performance before, during, or after an intermittent failure event may not be easily predicted, nor is it necessarily repeatable.
- However, an intermittent failure is often recurrent.

*Ref: Qi, Haiyu, Sanka Ganesan, and Michael Pecht. "No-fault-found and intermittent failures in electronic products." Microelectronics Reliability 48.5 (2008): 663-674.*

# No Fault Found

- No-Fault-Found (NFF): Failure (fault) occurred or was reported to have occurred during product's use. The product was tested to confirm the failure, but the testing showed "no faults" in the product.
- Trouble-Not-Identified (TNI): A failure occurred or was reported to have occurred in service or in manufacturing of a product. But testing could not identify the failure mode.
- Can-Not-Duplicate (CND): Failures that occurred during manufacture or field operation of a product could not be verified or assigned.
- No-Problem-Found (NPF): A problem occurred or was reported to have occurred in the field or during manufacture, but the problem was not found during testing.
- Retest-OK: A failure occurred or was reported to have occurred in a product. On retesting the product at the factory, test results indicated that there was no problem.

Qi, Haiyu, Sanka Ganesan, and Michael Pecht. "No-fault-found and intermittent failures in electronic products." *Microelectronics Reliability* 48.5 (2008): 663-674.

# The Impact of Intermittents

- Can not determine root cause and thus the reason for the failure (NFF)
- Reliability modeling analysis can be faulty
- Potential safety hazards
- Decreased equipment availability
- Long diagnostic time and lost labor time
- Complicated maintenance decisions
- Customer apprehension, inconvenience and loss of customer confidence
- Loss of company reputation
- Increased warranty costs
- Extra shipping costs



# NFF Test Sensitivities

Testing has five possible outcomes:

- Test can say it is good when it is good.
- Test can say it is bad when it is bad.
- Test can say it is good when it is bad.
- Test can say it is bad when it is good.
- Test can be inconsistent.

# Intermittent Failures in Electronic Assemblies

## Cause-and-Effect Diagram

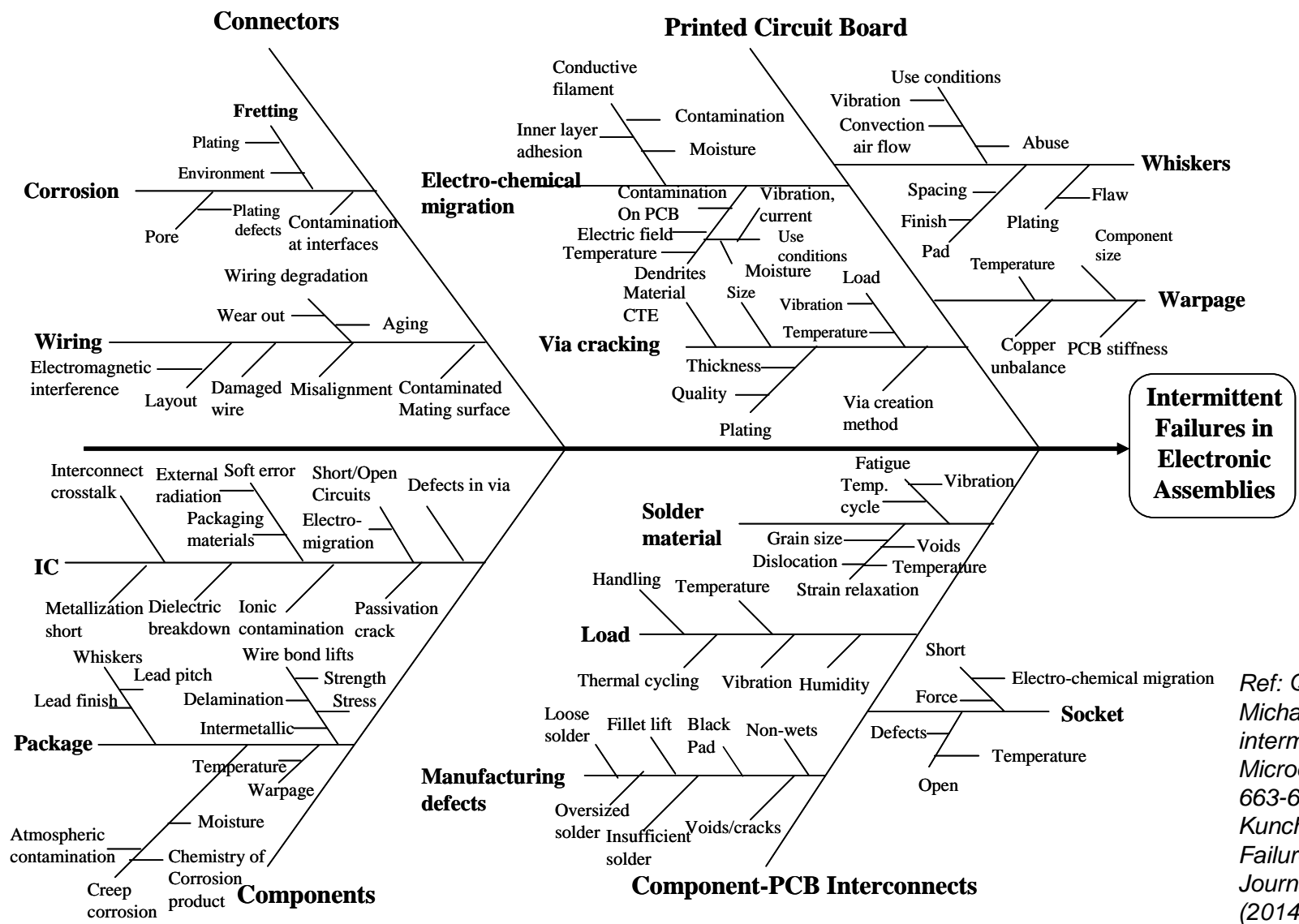

Ref: Qi, Haiyu, Sanka Ganesan, and Michael Pecht. "No-fault-found and intermittent failures in electronic products." *Microelectronics Reliability* 48.5 (2008): 663-674 and Bakhshi, Roozbeh, Surya Kunche, and Michael Pecht. "Intermittent Failures in Hardware and Software." *Journal of Electronic Packaging* 136.1 (2014): 011014.

# Characteristics of Intermittent Failures

- May indicate that a failure has occurred. Intermittent failure may be due to some extreme variation in field or use conditions.
- May indicate the imminent occurrence of failure.
- May not leave a failure signature making it difficult to isolate the site.

# Example: Intermittent Failures Due to Fretting Corrosion

- Tin alloys are soft metals on which a thin but hard oxide layer is rapidly formed.
- Being supported by a soft substrate, this layer is easily broken and its fragments can be pressed into the underlying matrix of soft, ductile tin-lead alloy.
- The sliding movements between contact surfaces break the oxide film on the surface and expose the fresh metal to oxidation and corrosion.
- The accumulation of oxides at the contacting interface due to repetitive sliding movements causes contact resistance to increase, leading to contact open.
- Tin based lead-free solders are expected to show similar fretting corrosion susceptibility as tin-lead solder coatings.

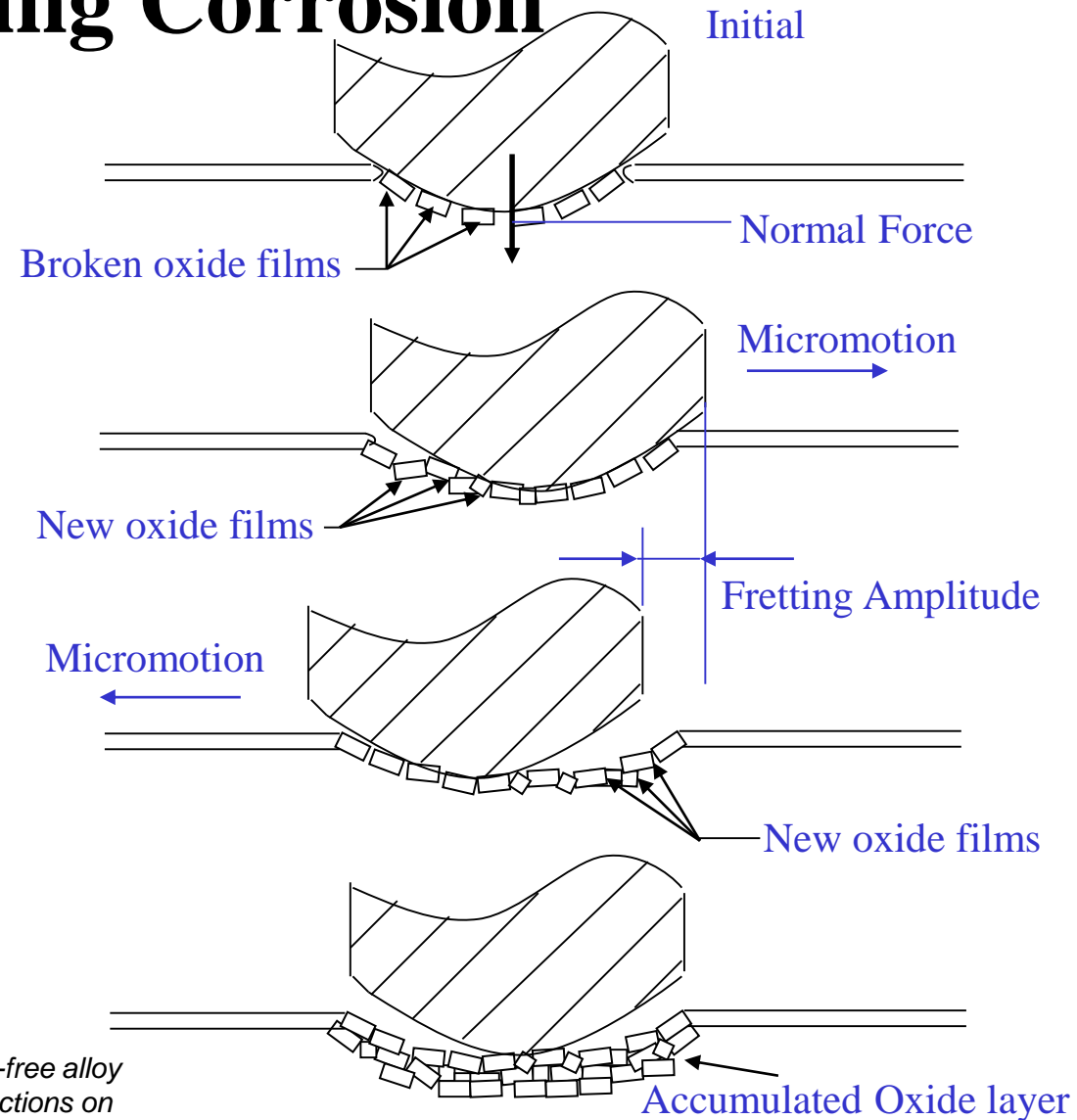

Ref: Wu, Ji, and Michael G. Pecht. "Contact resistance and fretting corrosion of lead-free alloy coated electrical contacts." *Components and Packaging Technologies, IEEE Transactions on* 29.2 (2006): 402-410.

# Electrical Contact Resistance vs. Fretting Cycles

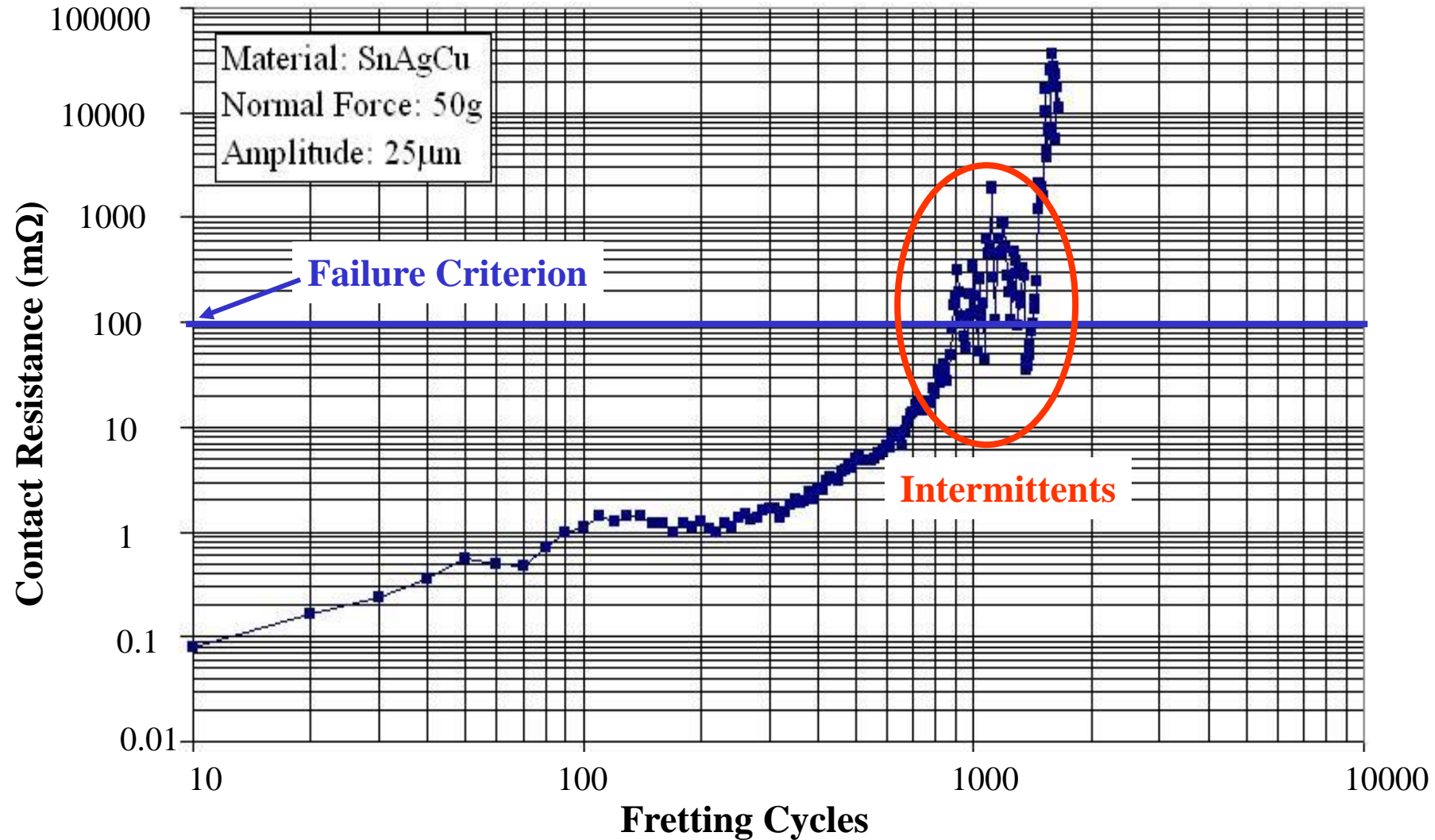

Ref: Wu, Ji, and Michael G. Pecht. "Contact resistance and fretting corrosion of lead-free alloy coated electrical contacts." *Components and Packaging Technologies, IEEE Transactions on* 29.2 (2006): 402-410 and Antler, Morton, and M. H. Drozdowicz. "Fretting corrosion of gold-plated connector contacts." *Wear* 74.1 (1981): 27-50.

# Example: Intermittent Failure Due to Improper Micro-via Plating in PCB

- A computer graphics OEM was experiencing intermittent failures on printed circuit boards with chip scale packages (CSPs) and ceramic ball grid array packages (CBGAs).
- High magnification metallurgical microscope imaging of micro-etched cross sections of micro-vias in the printed circuit board showed a separation of the via plating from the capture pad [Nektek Inc. Service Report, 2004].
- The plating separation was found to be the cause of intermittent failure.

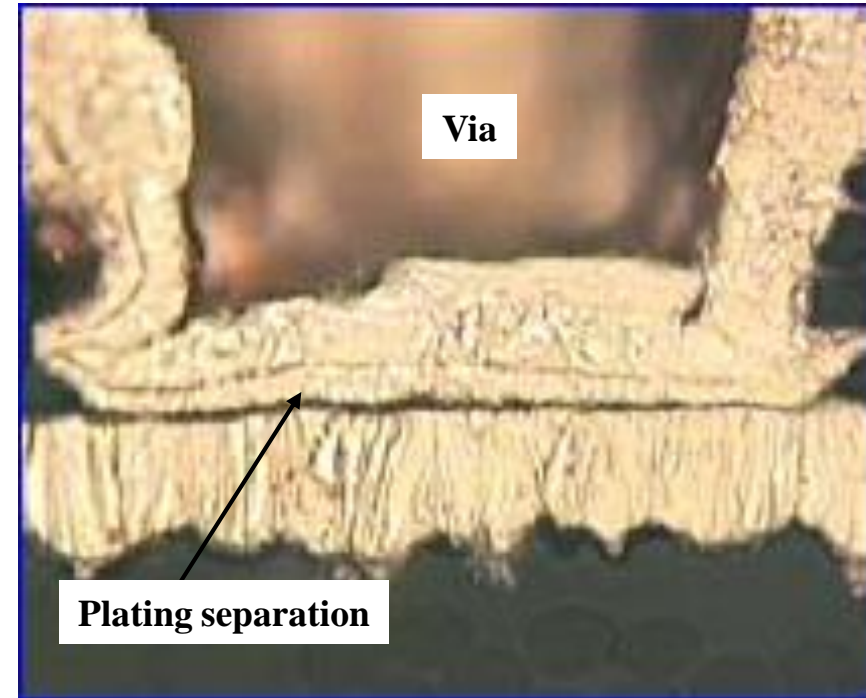

Plating separation at base of micro via  
[Nektek Inc. Service Report, 2004]

# Example: Intermittent Failure Due to Open Trace in PCB

- Open trace can also cause intermittent failures in PCB under environmental loading conditions.
- Under thermal cycling or vibration loading, the open trace may reconnect with intermittent electrical continuity observations.

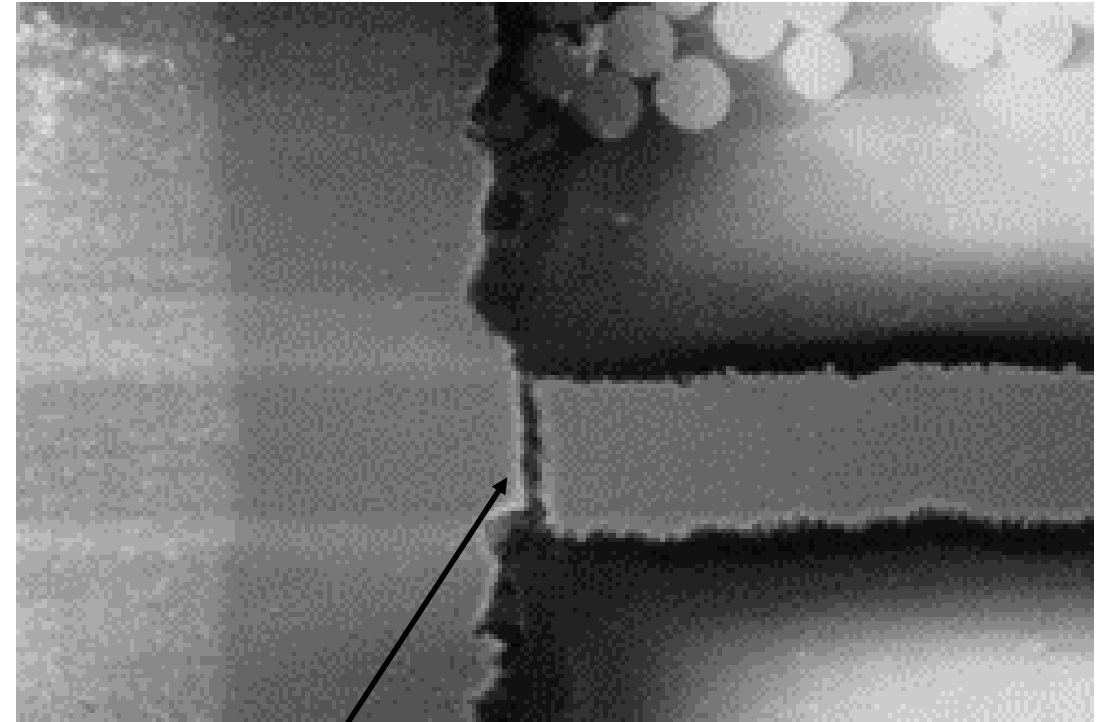

Open Trace

*Ref: A Study in Printed Circuit Board (PCB) Failure Analysis, Part 2, Insight Analytical Labs, Inc*

# Example: Intermittent Failures Due to Electro-chemical Migration (Surface Dendrites)

- Electrochemical migration (ECM) can cause shorts due to the growth of conductive metal filaments in a printed wiring board (PWB).
- Surface dendrites can form between the adjacent traces in the PWB under an applied voltage when surface contaminants and moisture are present.
- It is often difficult to identify the failure site because the fragile dendrite structure will burn upon shorting, often leaving no trace of its presence.

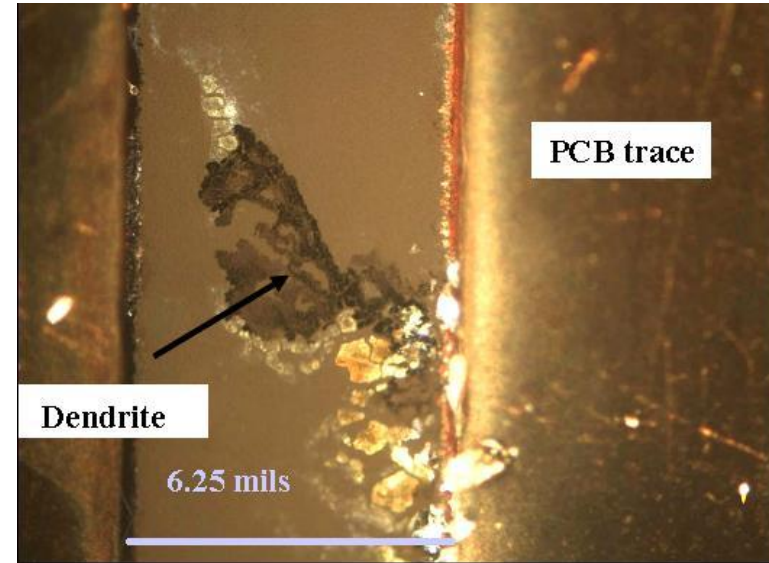

Dendritic growth during an ECM test

*Ref: Zhan, Sheng, Michael H. Azarian, and Michael Pecht. "Reliability of printed circuit boards processed using no-clean flux technology in temperature-humidity-bias conditions." Device and Materials Reliability, IEEE Transactions on 8.2 (2008): 426-434.*



# Example: Intermittent Failures Due to Electro-chemical Migration (Conductive Anodic Filament Formation)

- Conductive filament is formed internal to the board structure.
- In CAF, the filament is composed of a metallic salt, not neutral metal atoms as in dendritic growth.
- One of distinct signatures of CAF failures is intermittent short circuiting. The conductive filament bridging the two shorted conductors can blow out due to the high current in the filament, but can form again if the underlying causes remain in place.

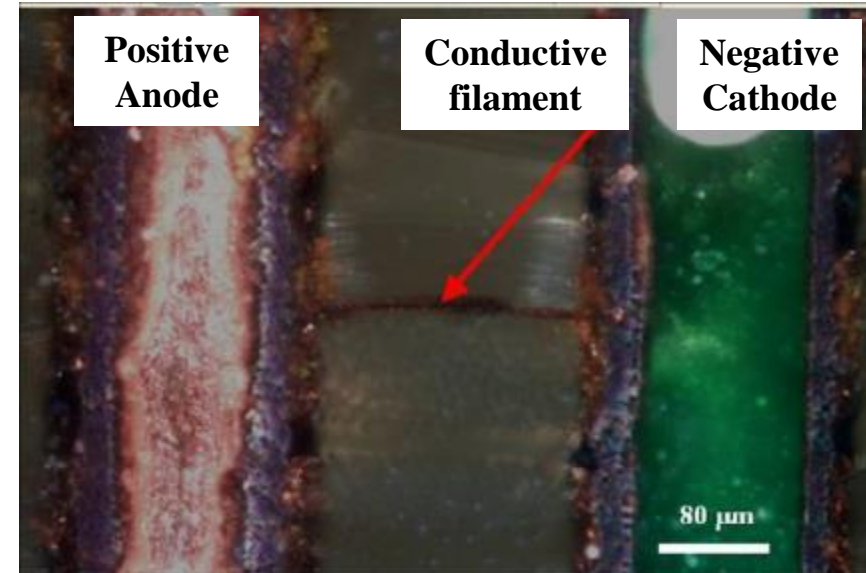

**A conductive filament bridging two plated through holes in a PWB**

*Ref: Sood, Bhanu, Michael Osterman, and Michael Pecht. "An Examination of Glass-fiber and Epoxy Interface Degradation in Printed Circuit Boards."*

# Electrical Resistance vs. Time Due to CAF

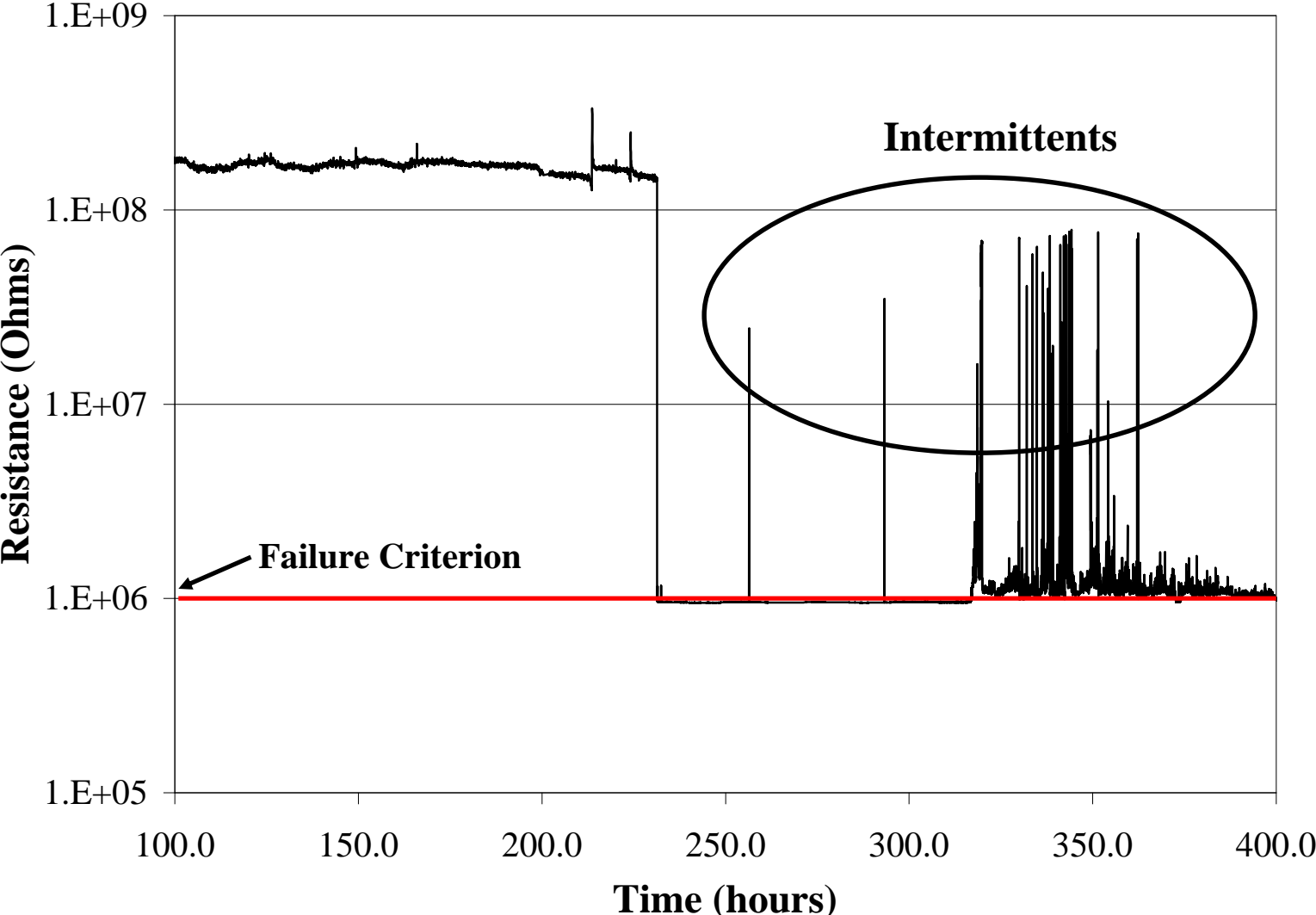

Ref: Sood, Bhanu, Michael Osterman, and Michael Pecht. "An Examination of Glass-fiber and Epoxy Interface Degradation in Printed Circuit Boards."

# Example: Intermittent Failures Due to Creep Corrosion

- Definition
  - Creep corrosion is a mass transport process in which solid corrosion products migrate over a surface.
- Failure mode
  - On IC packages, creep corrosion can eventually result in electrical short or signal deterioration due to the bridging of corrosion products between isolated leads.
  - Depending on the nature of the environment, the insulation resistance can vary and cause intermittents.

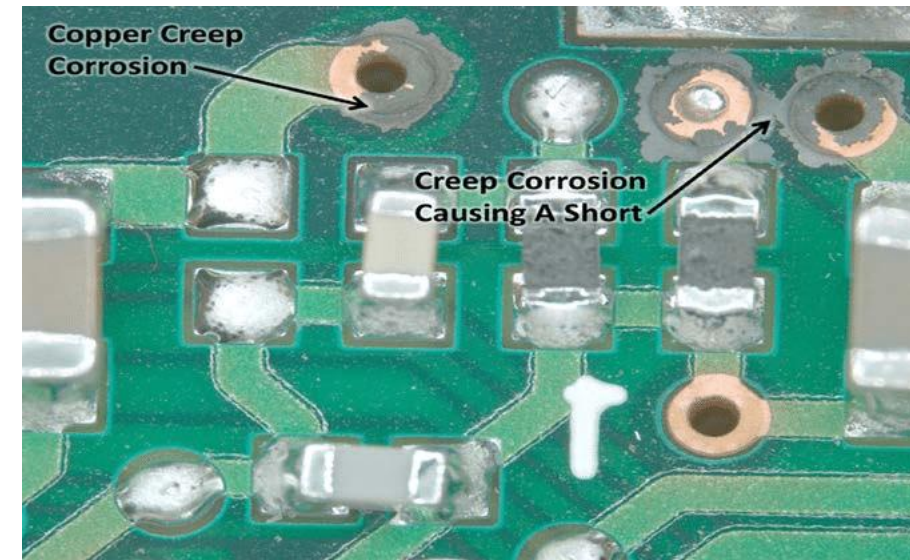

*Ref: Thesis "Reliability challenges in airside economization and oil immersion cooling", Jimil Shah, 2016.*

# Example: Intermittent Failures Due to Tin Whiskers



**Failed relay due to tin vapor arcing**

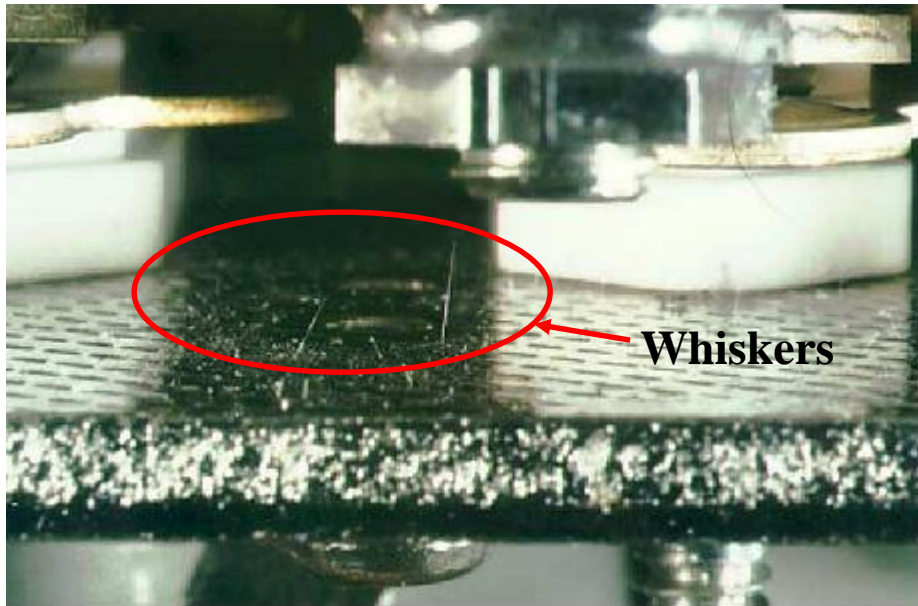

**Whiskers on the armature of a relay**

- Whiskers are elongated single crystals of Sn which grow spontaneously out of the surface. Internal stresses within the plated deposit drives growth.
- Tin (and other conductive) whiskers or parts of whiskers may break loose and bridge isolated conductors, resulting in an intermittent short circuit. These field failures are difficult to duplicate or are intermittent because at high enough current the conductive whisker can melt, thus removing the failure condition. Alternatively, disassembly or handling may dislodge a failure-producing whisker.
- Failure analysis concluded that tin whiskers initiated the current surge to the ground. Once a whisker bridged a terminal stud to the armature, plasma arcing could occur with enough voltage and current to damage the relay.

**Photos : Northrop Grumman and Ref: Davy, Gordon. "Relay Failure Caused by Tin Whiskers." (2002).**

# Example: Intermittent Failures Due to Black Pad

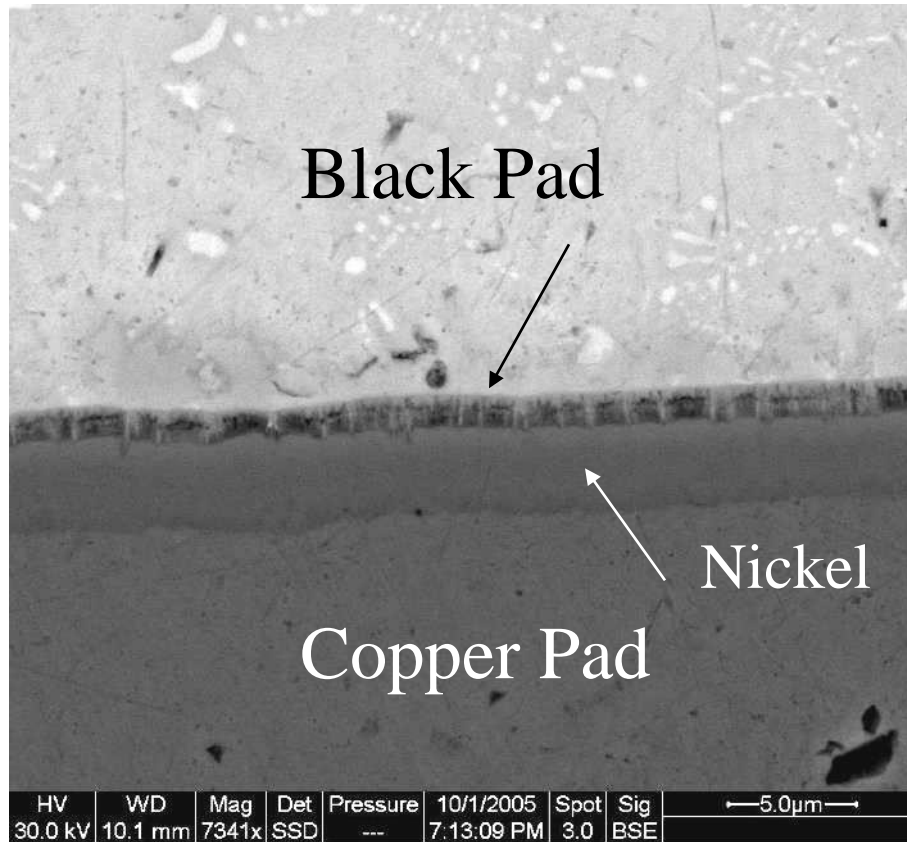

- The ‘Black Pad’ phenomenon in Electroless Nickel over Immersion Gold (ENIG) board finish manifests itself as gray to black appearance of the solder pad coupled with either poor solderability or solder connection, which may cause intermittent electrical ‘opens.’
- Bulwith et al. [2002] identified numerous Ball Grid Array (BGA) package intermittent electrical open failures to be black pad related.

Zeng, Kejun, et al. "Root cause of black pad failure of solder joints with electroless nickel/immersion gold plating." *Thermal and Thermomechanical Phenomena in Electronics Systems, 2006. IThERM'06. The Tenth Intersociety Conference on. IEEE, 2006.*

# CASE STUDY\*

## Failure Analysis of Multilayer Ceramic Capacitor (MLCC) with Low Insulation Resistance

\* Adapted from:

1. Shrivastava, A., Sood, B., Azarian, M., Osterman, M., & Pecht, M. (2010, June). *An investigation into a low insulation resistance failure of multilayer ceramic capacitors. In Electronic Components and Technology Conference (ECTC), 2010 Proceedings 60th (pp. 1811-1815). IEEE.*
2. Brock, Garry Robert. *"The Effects of Environmental Stresses on the Reliability of Flexible and Standard Termination Multilayer Ceramic Capacitors." PhD diss., 2009.*

# MLCC Construction

- Ceramic Dielectric
  - Typically comprised of compounds made with titanium oxides
    - BaTiO<sub>3</sub> (“X7R”) for this study
- Electrodes
  - Base metal consisting of nickel (BME)
    - Precious metal consisting of silver/ palladium (PME)
- End Termination
  - Standard termination consists of silver or copper coated with nickel and tin
    - Flexible termination consists of a silver filled polymer coated with nickel and tin

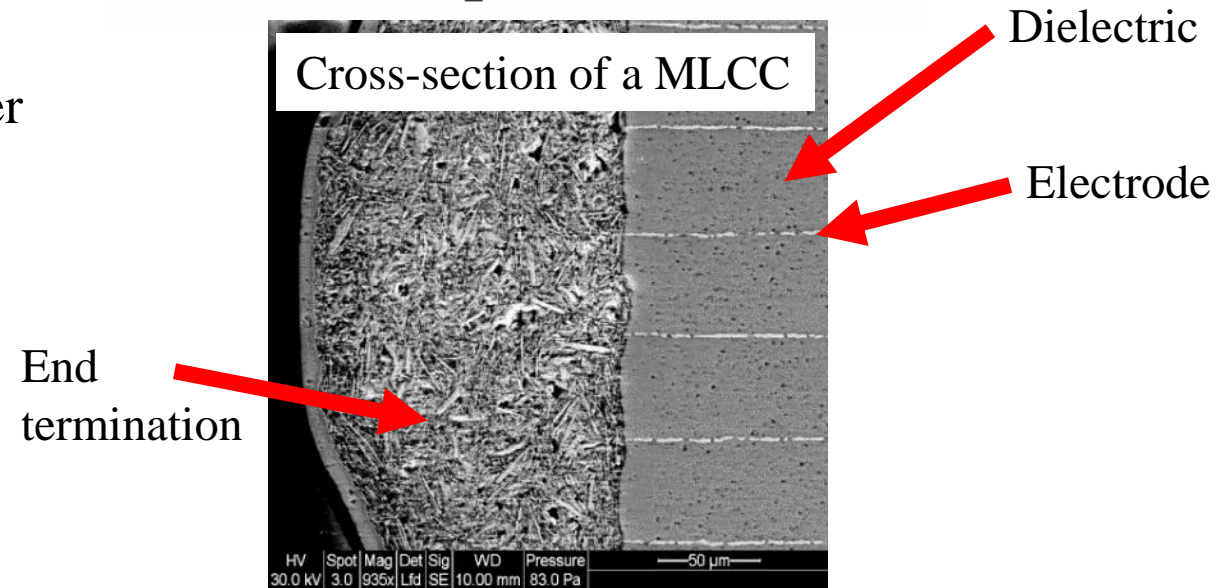
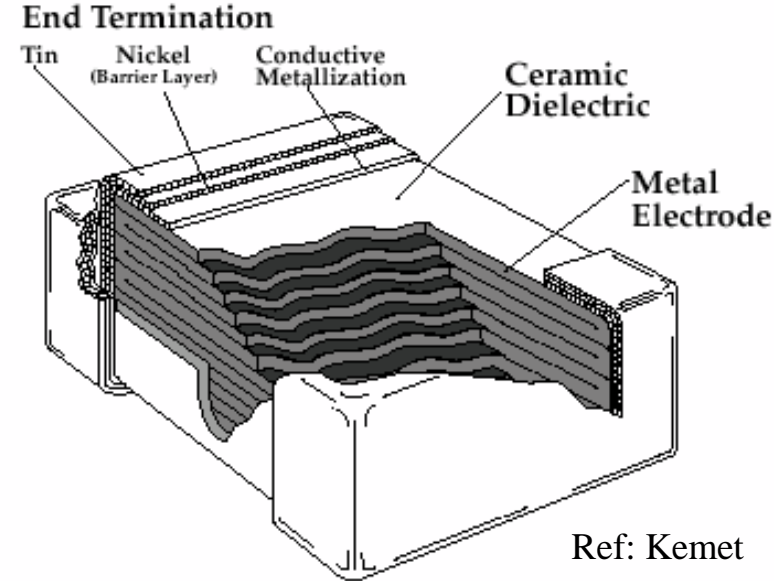

# Loading Conditions: Temperature-Humidity-Bias

- A Temperature-Humidity-Bias (THB) test was performed for 1766 hours at 85° C and 85% RH, at the rated voltage of 50V.
- Capacitance, Dissipation Factor (DF) and Insulation Resistance (IR) were monitored during the test.
- A 1 MΩ resistor was placed in series with each of the MLCCs.
- The MLCCs were size 1812 and soldered to an FR-4 printed circuit board using eutectic tin-lead solder.

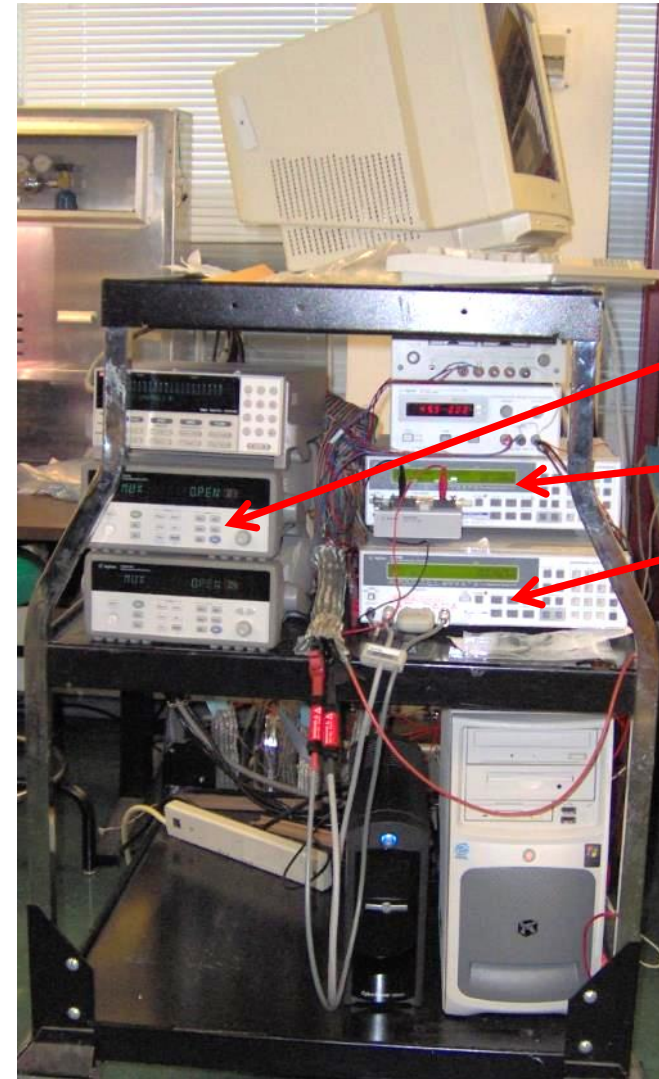

Data Acquisition, Temp.

LCR Meter: C, DF

High Resistance Meter: IR



# IR Test Data for Failed Flexible Termination MLCCs

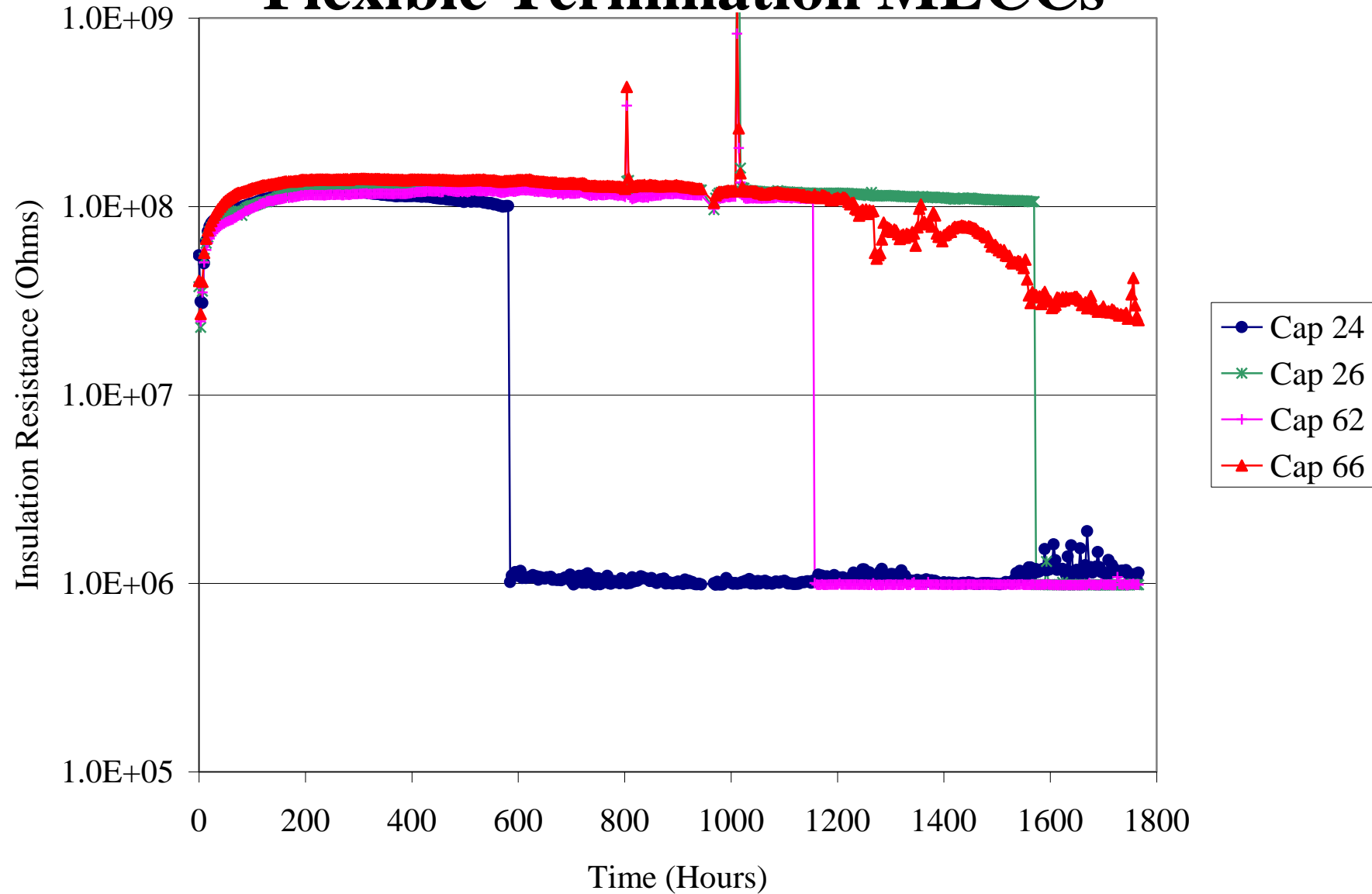

# THB Failure Analysis Methodology for Biased MLCCs

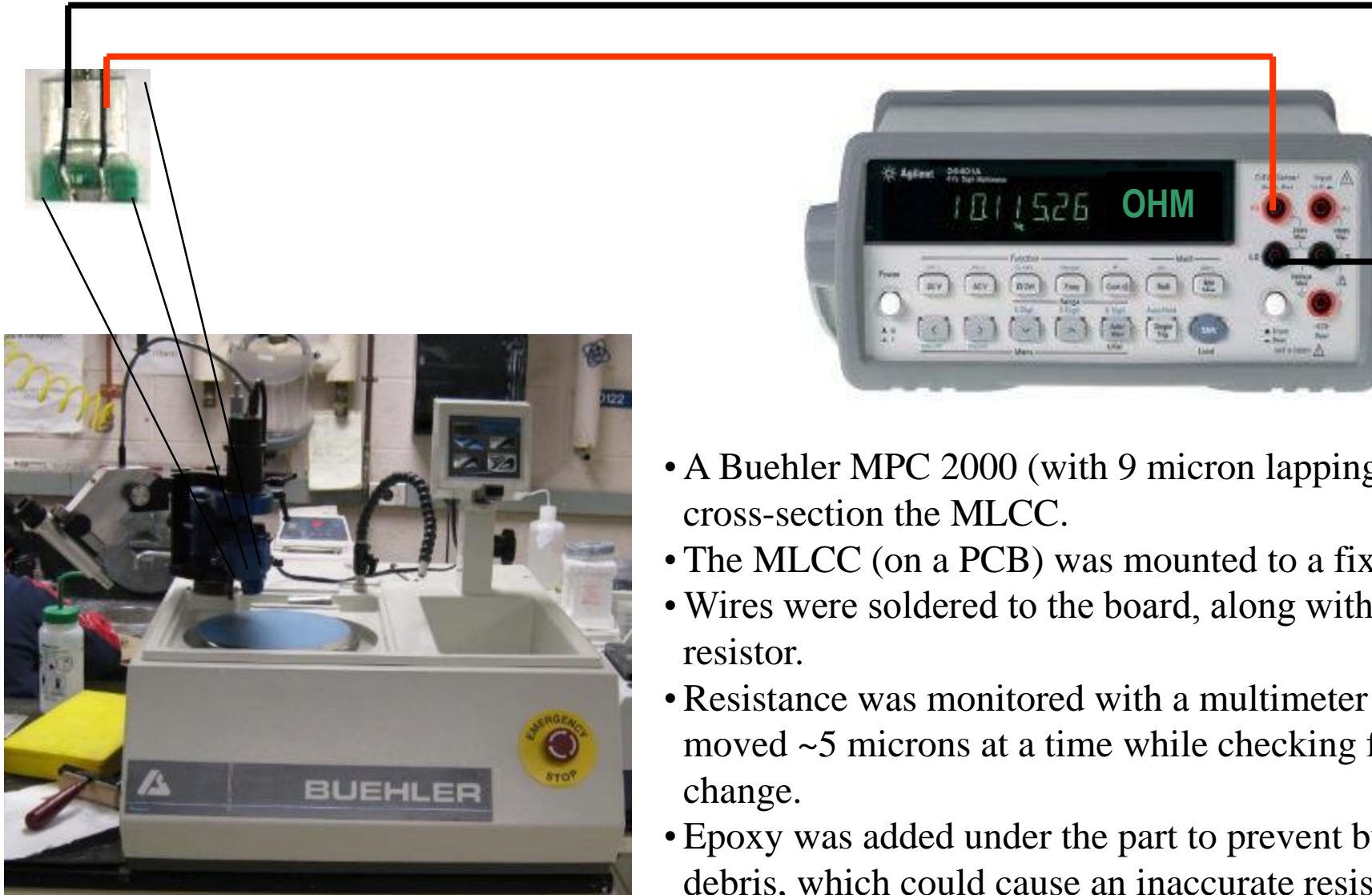

- A Buehler MPC 2000 (with 9 micron lapping film) was used to cross-section the MLCC.
- The MLCC (on a PCB) was mounted to a fixture using wax.
- Wires were soldered to the board, along with a 1 kΩ series resistor.
- Resistance was monitored with a multimeter as the sample was moved ~5 microns at a time while checking for a resistance change.
- Epoxy was added under the part to prevent buildup of metal debris, which could cause an inaccurate resistance value.

# Metal Migration Between Electrodes

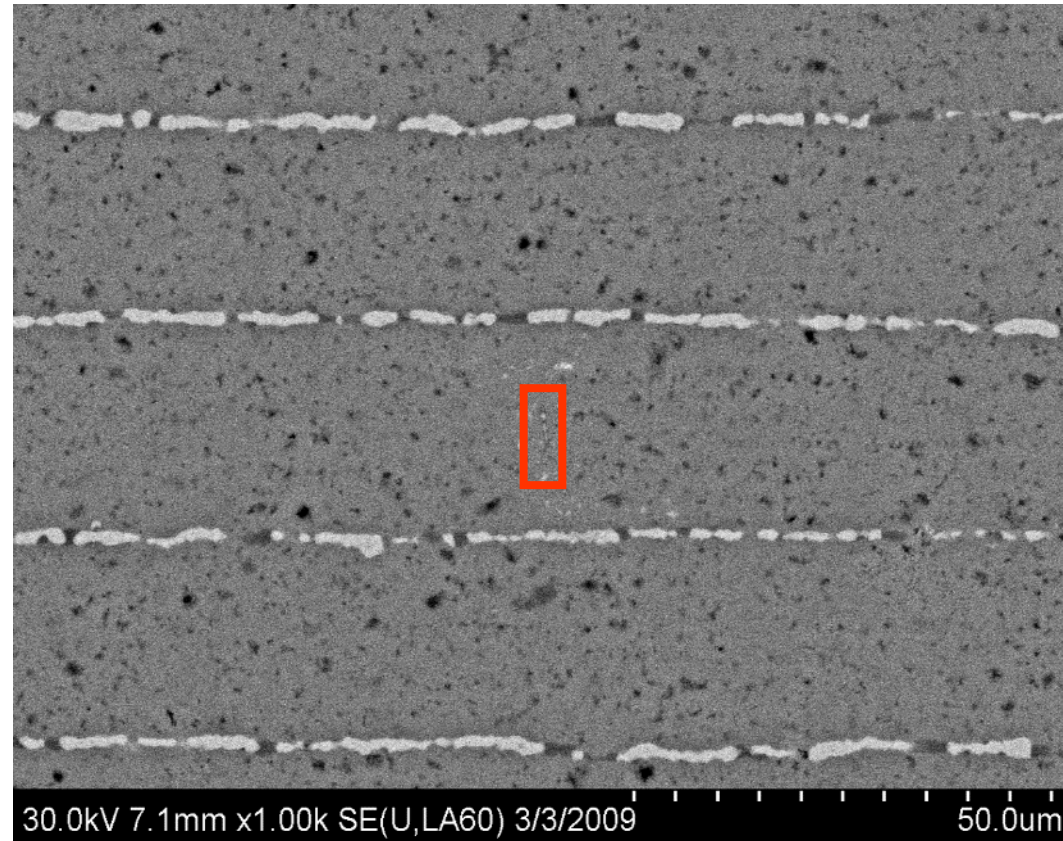
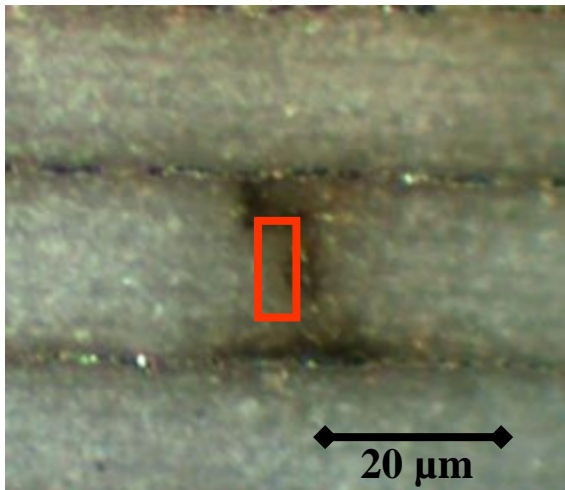
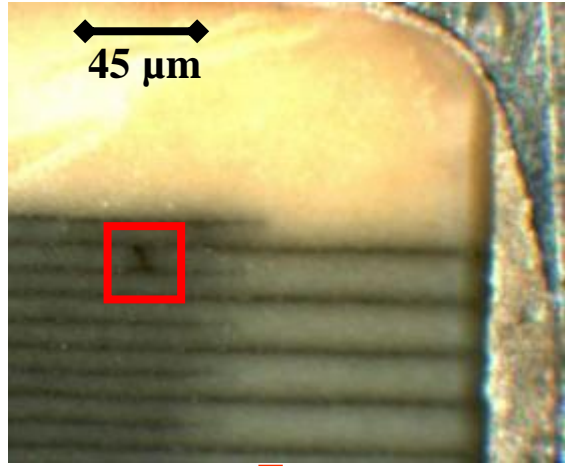

Optical Micrographs of Cross-section

SEM Image of Cross-section

# EDS Line Scan Showing Silver and Palladium in Area of the Metallic Bridge

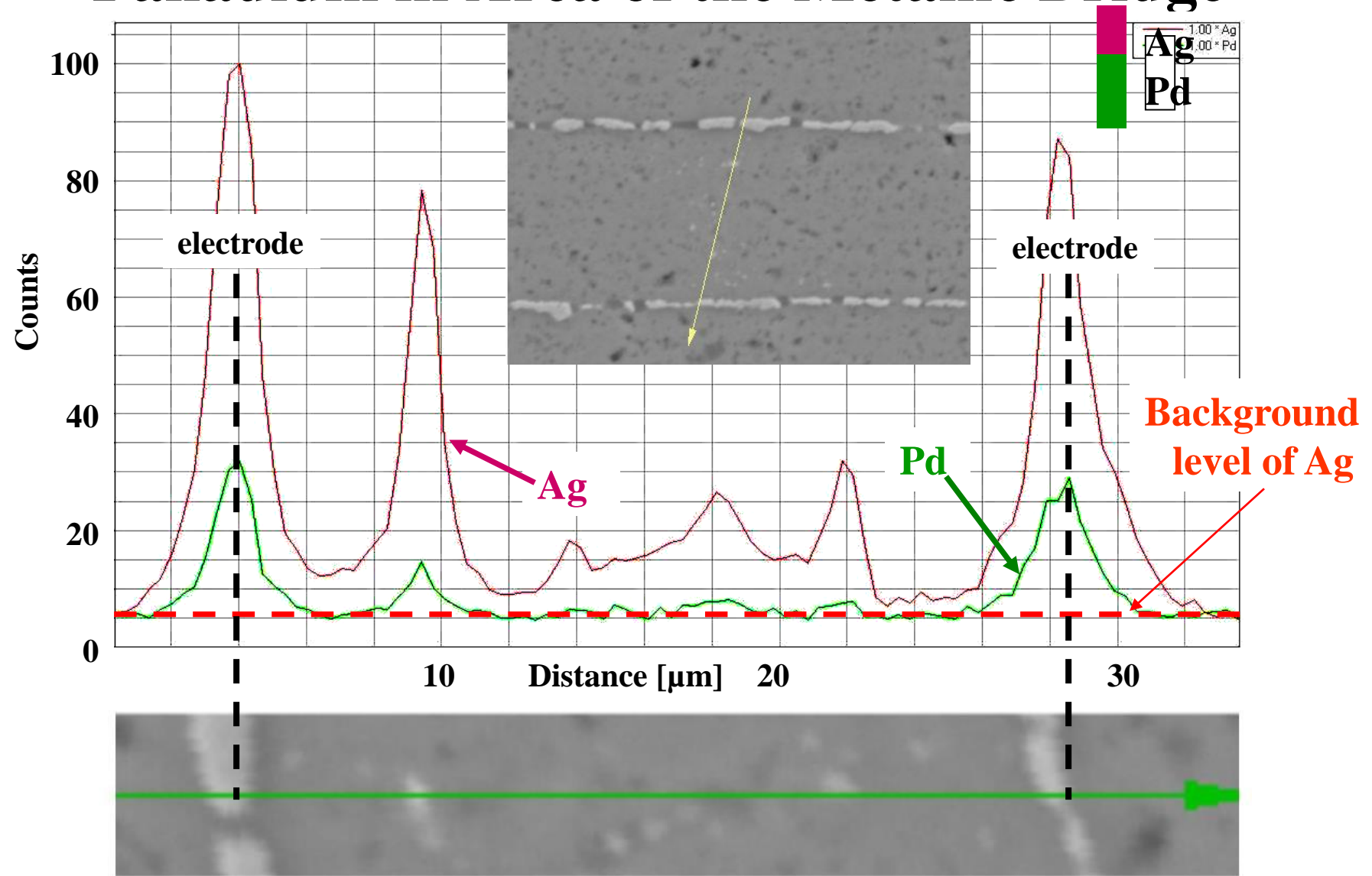

# EDS Map Showing Silver Migration and Voiding in Ceramic

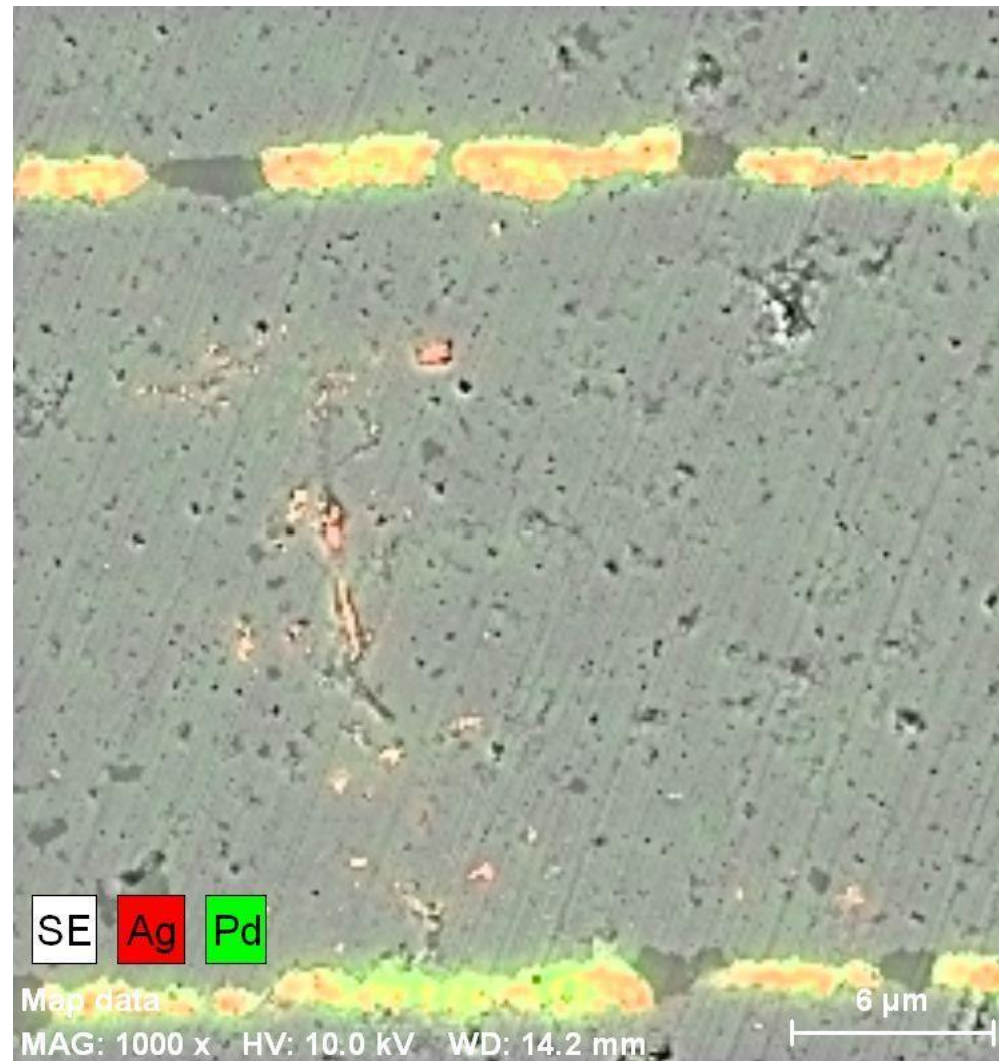

# Failure Mechanism

- Metal migration was found in several of the failed MLCCs.
- Voids in the ceramic, without silver or palladium, were also found close to the conduction path.
- The failure mechanism was electrochemical co-migration of silver and palladium, aided by porosity in the dielectric.

# Non-Destructive Techniques

- Electrical Testing
- Scanning Acoustic Microscopy (SAM)
- X-ray Inspection
- X-ray Fluorescence (XRF)
- Optical Inspection

# Electrical Testing of Components and Printed Circuit Boards



# Electronic Testing Equipment

- Digital meters
  - Multimeters
  - Specialized parametric meters, such as LCRs, high resistance meters, etc.
- Oscilloscopes, Spectrum Analyzers
- Curve tracer/Parameter Analyzers
- Time Domain Reflectometers
- Automated Test Equipment (ATE)

# Digital Multimeters

- Typically provide:
  - Voltage (DC, AC rms)
  - Resistance (2 wire)
  - Current
- Other common options:
  - Resistance (4 wire)
  - Frequency or count
  - Diode voltage
  - Capacitance
  - Temperature
  - Datalogging



Agilent 34401A

# LCR Meters and Impedance Analyzers

- Variable AC voltage and frequency.
- Used to characterize
  - Capacitors
  - Inductors
  - Transformers
  - Filters
  - Dielectric materials (e.g., PCB substrates)



Agilent 4263B

# High Resistance Meters

- Typically measure:
  - Leakage current
  - Insulation resistance
- Common applications:
  - Insulation resistance of dielectrics (capacitors, substrates)
  - Surface insulation resistance of PCBs



Agilent 4339B

# Oscilloscopes and Spectrum Analyzers

- Digital scopes allow:
  - Waveform storage
  - Capture of transients
  - Waveform measurements
  - Math (e.g., FFT)
  - Complex triggering
- Spectrum analyzers are used for frequency domain measurements.

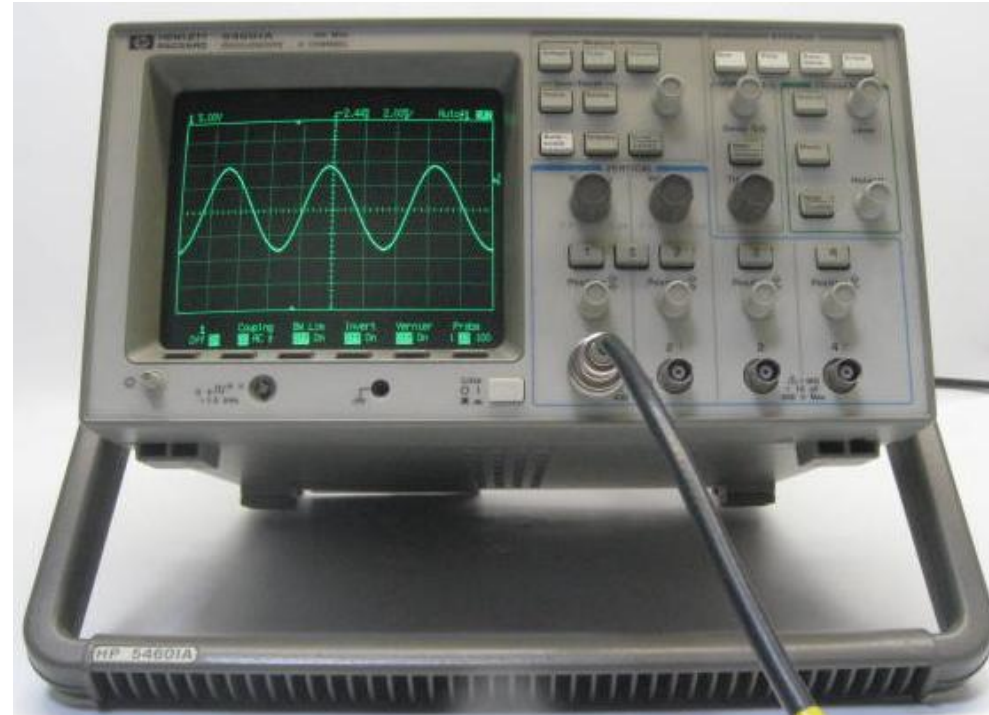

Agilent 54601

# Curve Tracer or Parameter Analyzer

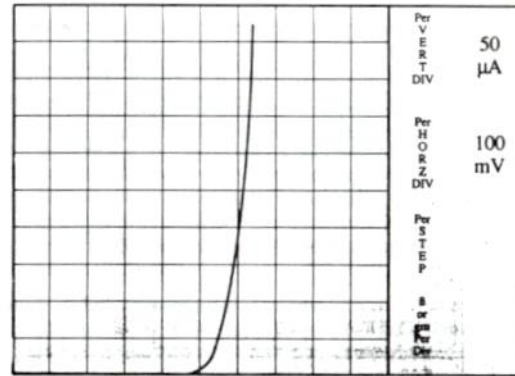
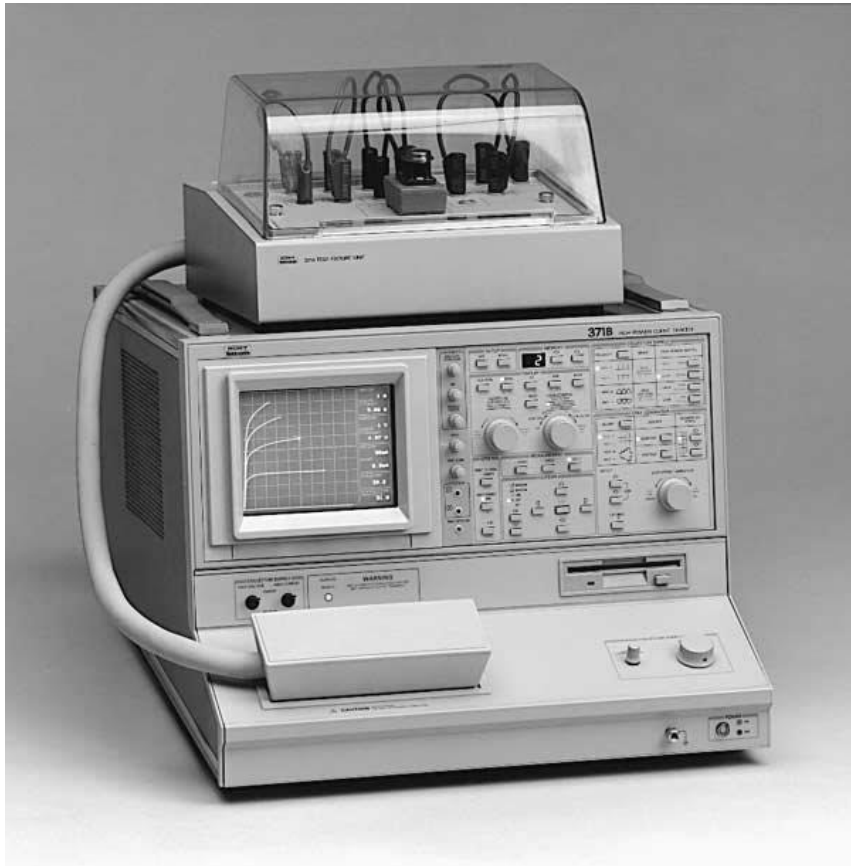

Normal I-V curve

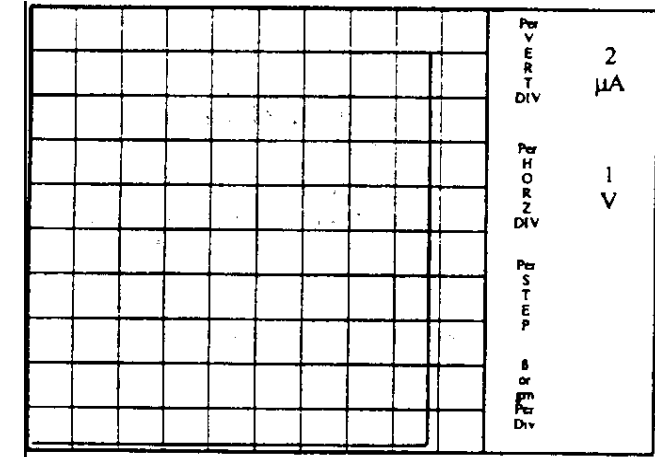

Normal I-V curve

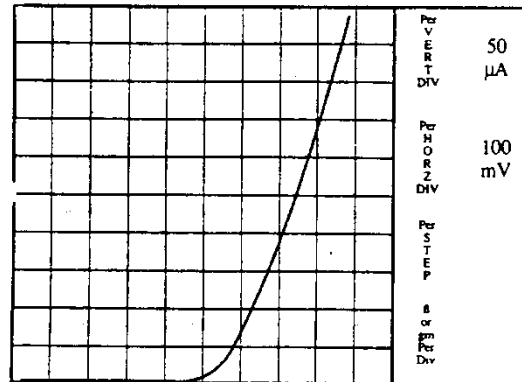

Abnormal I-V curve (due to the presence of a series resistance)

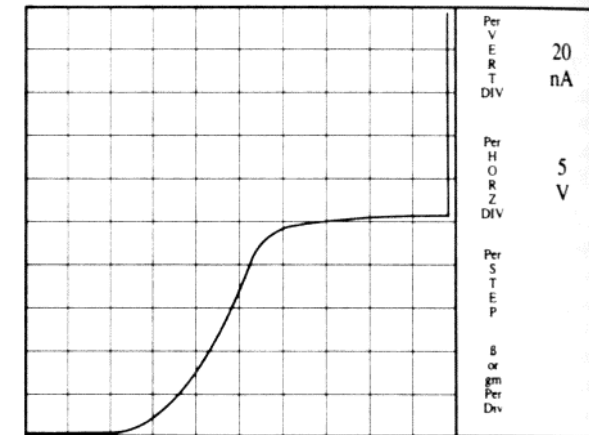

Abnormal I-V curve – Ionic Contamination (Reverse Bias)

- Low frequency display of voltage versus current

# Automated PCB Test Equipment

- Dedicated Wired Grid – test probes wired to the grid. High cost.
- Universal Grid (“Bed of Nails”) –Low cost, reusable. Spring loaded or rigid test probes in mechanical contact to the grid.
- Flying Probe or Fixtureless System with moveable single or double probes. Expensive. Empirical techniques applied on capacitance /impedance data to determine a good board. Good for micro products. Issues with pad damage.

# Scanning Acoustic Microscopy



# Common Applications

## Defects specific to IC packages include:

- Delamination at wirebonds, substrate metallization, dielectric layers, element attaches, and lid seals.
- Die-attach field-failure mechanisms induced by improper die mounting and de-adhesion.
- Delamination of the molding compound from the leadframe, die, or paddle
- Molding compound cracks
- Die tilt
- Voids and pinholes in the molding compound and die attach

## Other applications:

- Flip Chips
- Bonded Wafers
- Printed Circuit Boards
- Capacitors
- Ceramics
- Metallic
- Power Devices/Hybrids
- Medical Devices
- Material Characterization

# Common Applications

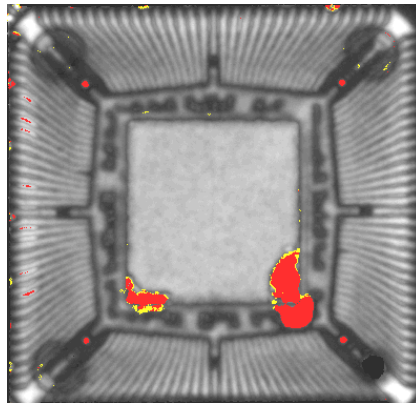

**Die Top  
Delamination**

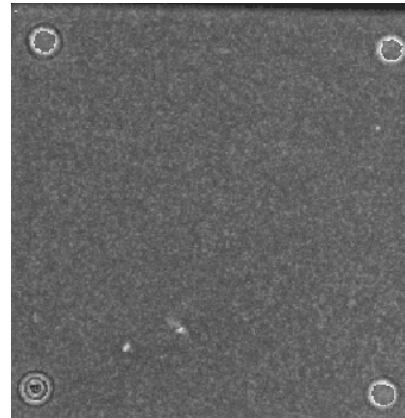

**Mold compound voids**

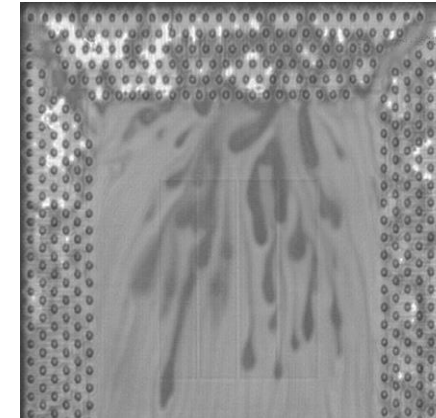

**Flip Chip Underfill  
Voids**

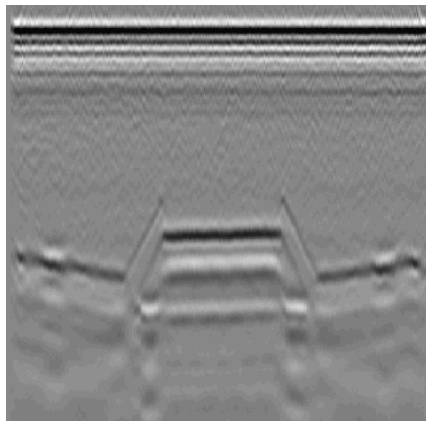

**Die Tilt, B-Scan**

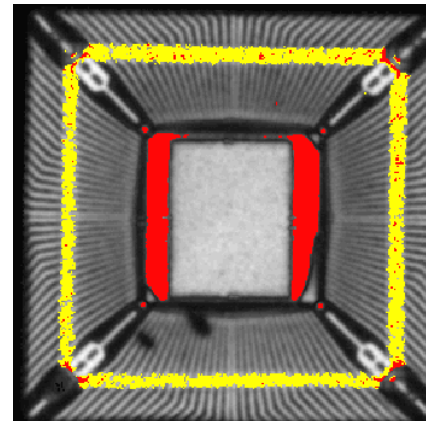

**Die Pad delamination**

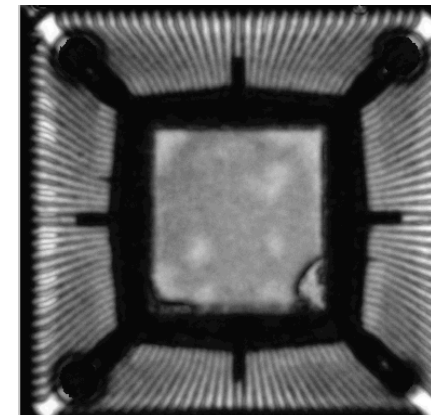

**Die Attach Voids**

Ref: Moore, T. M. "Identification of package defects in plastic-packaged surface-mount ICs by scanning acoustic microscopy." ISTFA 89 (1989): 61-67 and Briggs, Andrew, ed. *Advances in acoustic microscopy*. Vol. 1. Springer Science & Business Media, 2013.

# Scanning Acoustic Modes

A-Scan: Raw ultrasonic data. It is the received RF signal from a single point (in x,y).

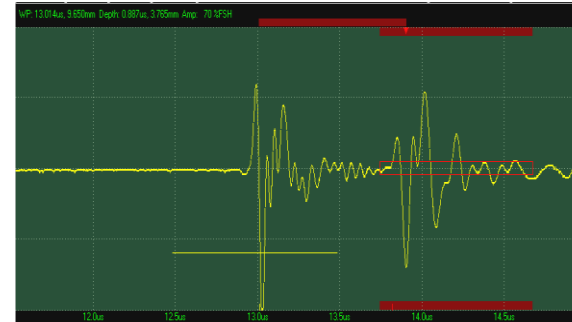

B-Scan: Line of A-scans. (Vertical cross-section)

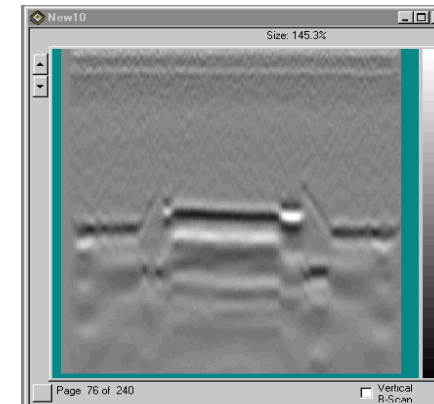

C-Scan: Data from a specified depth over the entire scan area. (Horizontal cross-section).

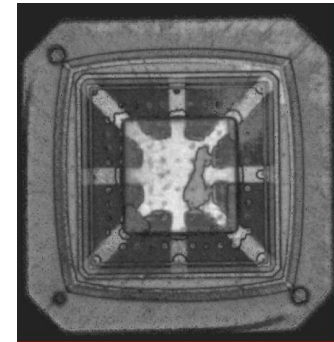

# Limitations of the Techniques

- Materials and interfaces of interest have to be flat (i.e., not useful on solder balls or joints unless at a flat interconnection sites).
- Materials have to be relatively homogeneous (not practical for PWB internal examination, hence not applicable for BGAs on PWB substrates, but allowable for BGAs on ceramic).
- Metals tend to interfere with the acoustic signal (i.e., unable to examine underneath of metal layers such as a copper die paddle or an aluminum heat sink. The copper metallization on PWBs is another hindrance for their internal examination).
- Operator needs to be highly skilled to correctly acquire and interpret data.
- Since resolution and penetration depth are inversely related, a trade off must be made.

# X-ray Radiography

# Applications and Examples

Typical applications include:

- Internal structures of electronic devices
- Connection techniques (Flip Chip,  $\mu$ BGA, BGA, MCM, COB)
- Inner layers of PCBs

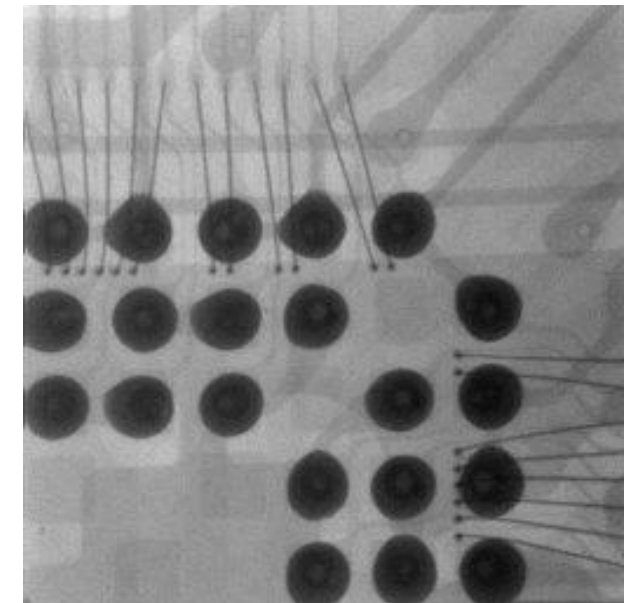
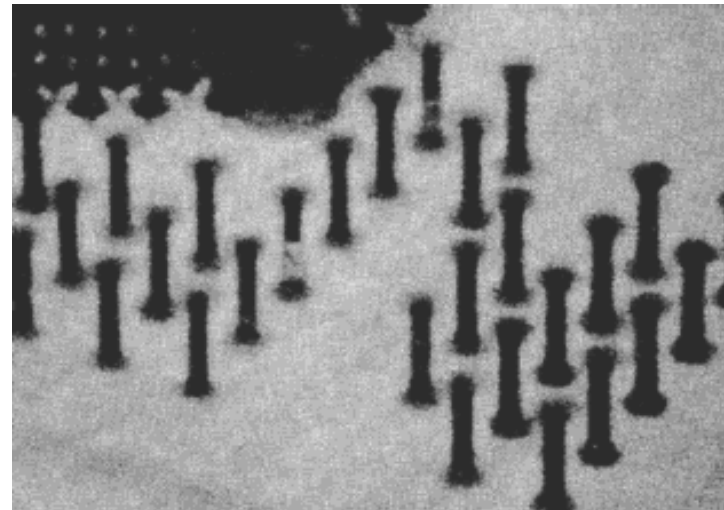
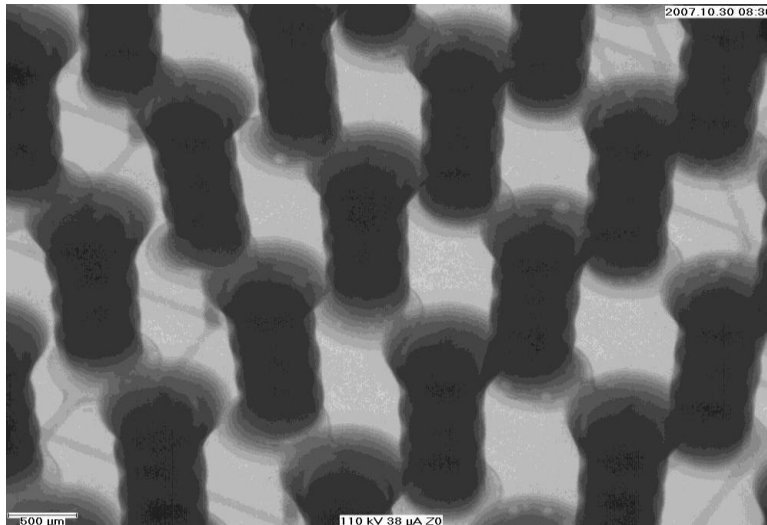
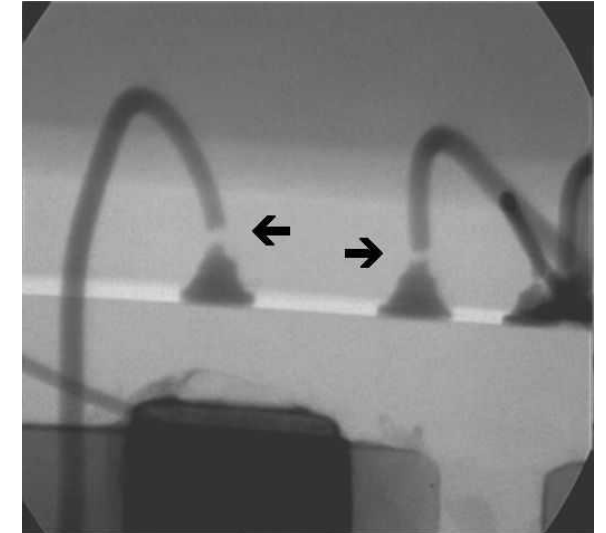
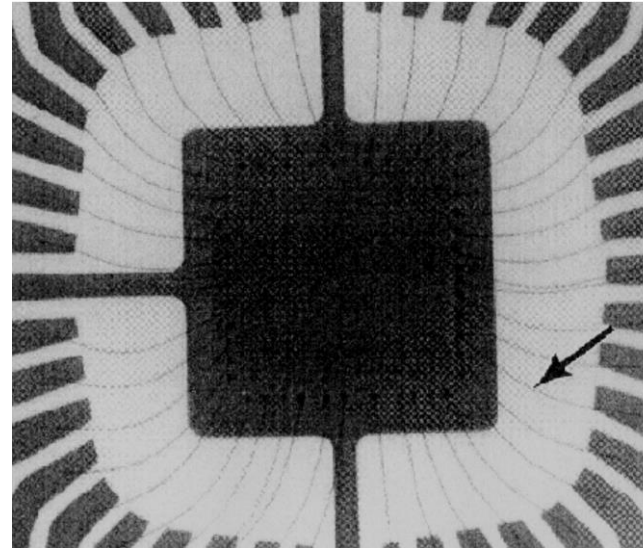

# Applications: CT Visualization and Software

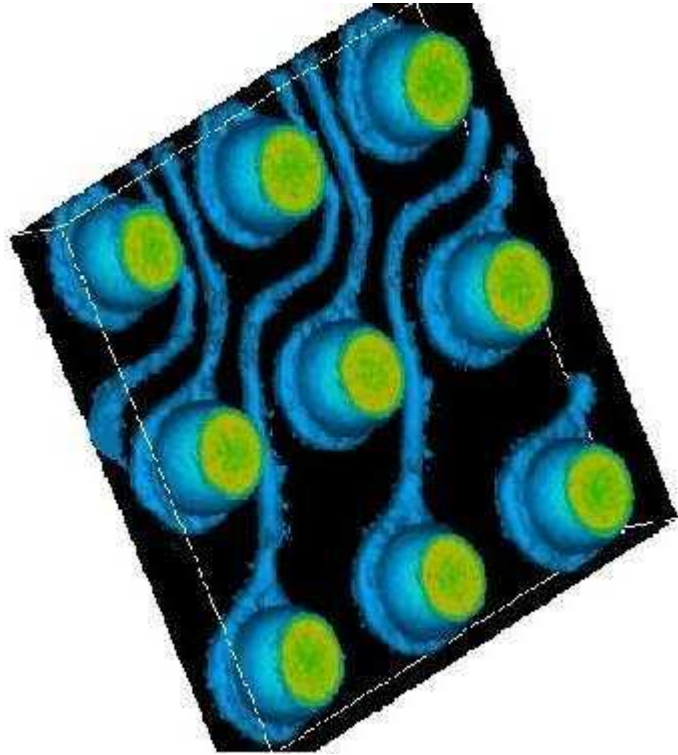

The computed tomography (CT) technique enables 3-dimensional inspection of planar components as seen in this BGA assembly.

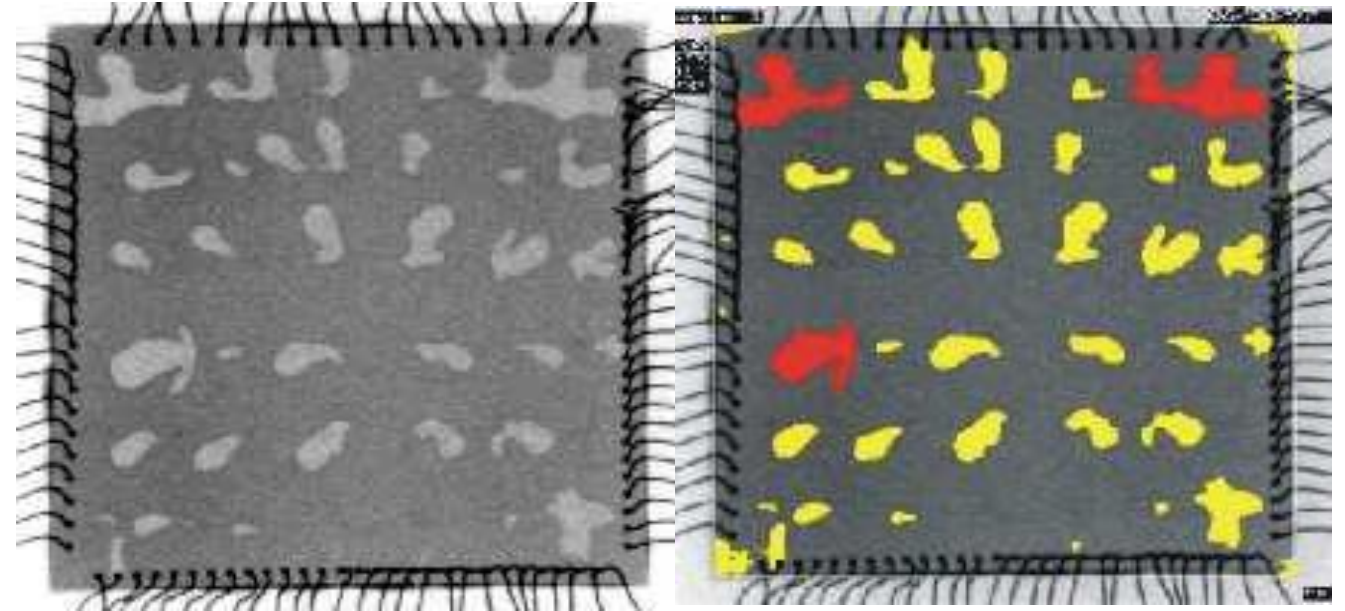

Use of voiding calculation software enables the estimation of voided area observed in die attach. Given a nominal size area, voids can be color coded for easier visualization of areas larger than or smaller than these dimensions. The yellow represent normally sized voids, whereas, the red ones are larger.

# Limitations of X-ray Techniques

- Although considered a non-destructive test, X-ray radiation may change the electrical properties of sensitive microelectronic packages such as EPROMS, and hence should not be used until after electrical characterization has been performed on these devices.
- For samples on or below thick metal layers such as large heat sinks as seen in power devices, X-ray imaging is more difficult and requires high voltages and currents.
- Magnification using contact X-ray equipment can only be done externally by a magnified view of the 1:1 photo, or from an enlarged image of the negative. Hence, resolution will decrease as the image is enlarged.
- The operator may have to experiment with voltage settings and exposure times, depending on the type of sample and film used, to obtain proper contrast and brightness in the photos.



# X-Ray Fluorescence (XRF)

# Types of Analysis

- Spectrum analysis to determine the elements and the composition of an unknown sample.
- Material analysis for bulk samples (one layer sample)
- Thickness analysis to determine the thickness and the composition of different layers.
- Pure element and alloy standards (such as Ni, Cu, Ag, Sn, Au, Pb and SnAgCu or SnPb alloys) can be used to calibrate the spectrometer.

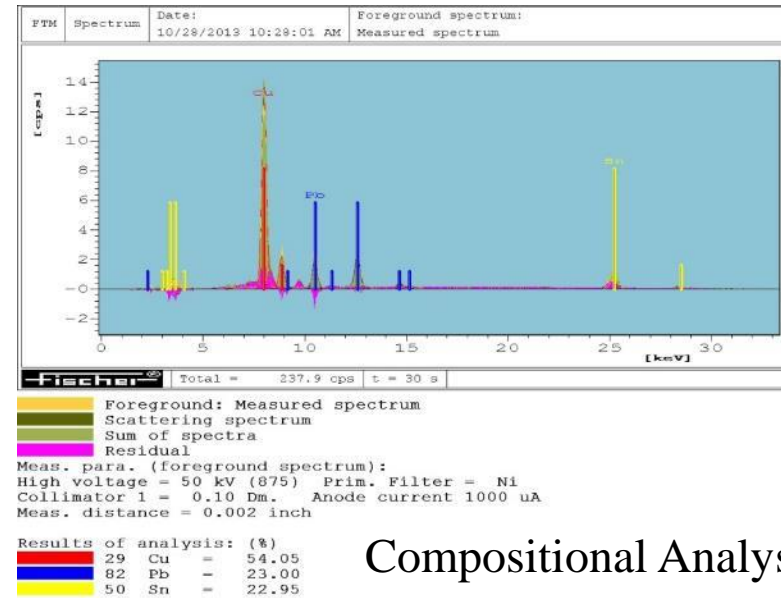

Compositional Analysis

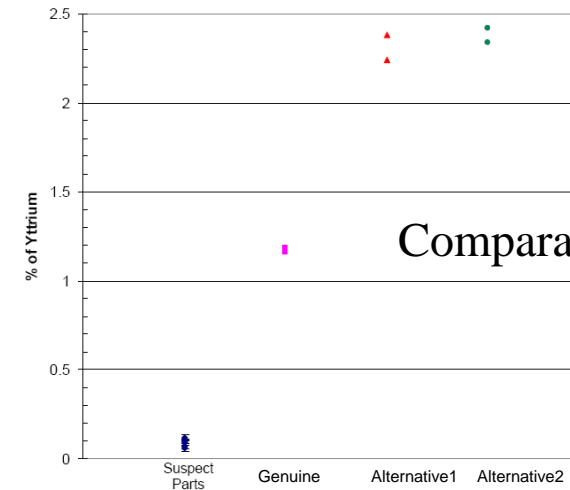

Comparative Analysis

# Background on X-Ray Fluorescence

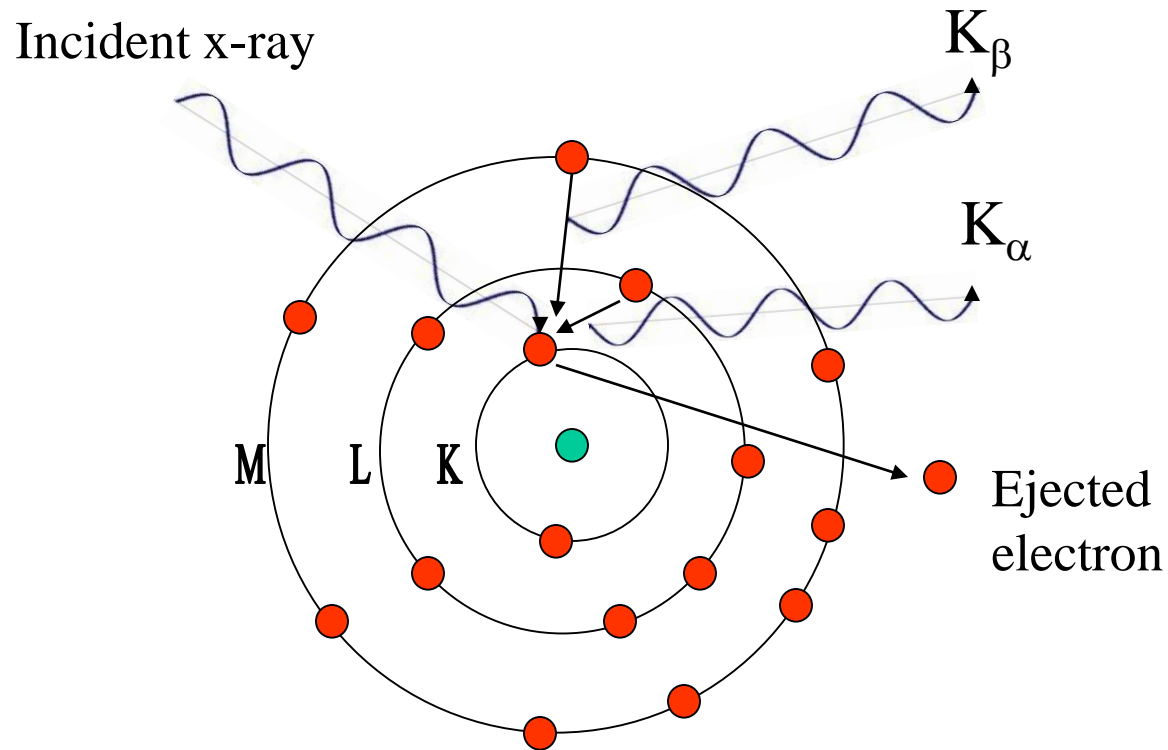

- Incident x-ray is incident on sample
- Core electron is ejected
- Electron from outer shell falls down to fill up the vacancy
- X-ray photon is emitted (energy equal to the difference between the two levels involved in the transition), which is characteristic of the element and the electronic transition

# Conclusion

- XRF is a powerful tool to analyze composition and coating thickness on a variety of electronic products
- A non-destructive tool, does not require sample preparation, provides quick analysis results
- Users should be aware of the issues related to the automated analysis software

# Visual Inspection

# External Visual Inspection

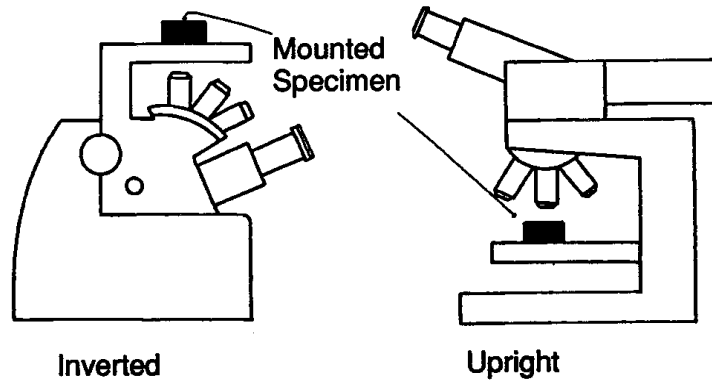

Low power stereo  
macroscope (up to 65x)

- Overview
- Package level
- PCB level

Higher power light optical  
microscopes

- Inverted
- Upright



Typical stereo microscope

# Analytical Techniques

- Environmental Scanning Electron Microscopy (ESEM)
- Energy Dispersive Spectroscopy (EDS)
- Thermo-mechanical Analysis
- Microtesting (Wire Pull, Ball Bond and Solder Ball Shear, Cold Bump Pull)
- Decapsulation / Delidding
- Dye Penetrant Inspection (Dye and Pry)

# Discussion 2 – PTH

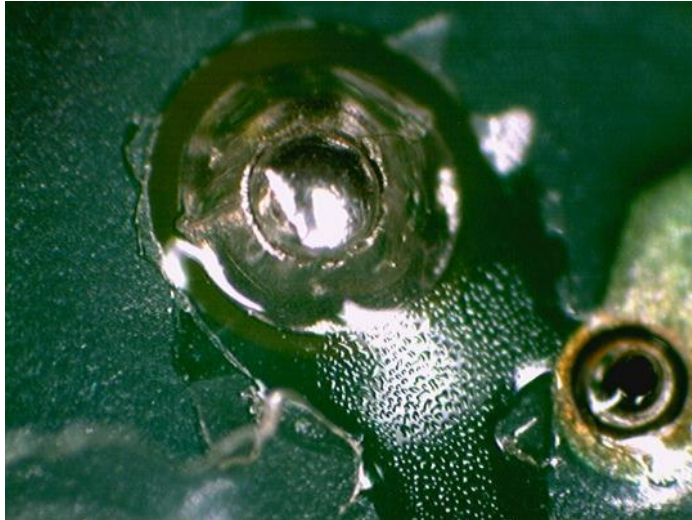

Through Hole Varistor

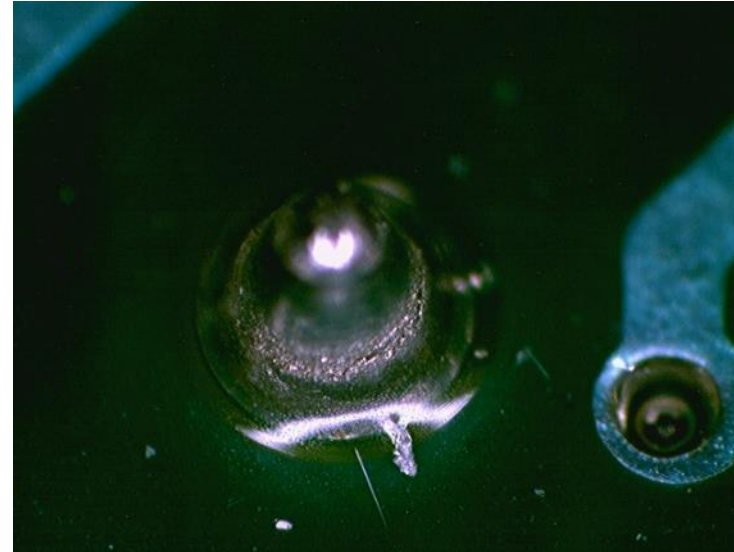

Through hole Cracking

What is the mode, mechanism and root cause (s) ?



# Scanning Electron Microscopy

# Applications and Examples

- Excessive wicking of copper in PTHs of a PWB
- Separation at the interface between the copper plating and the fiber epoxy resin board interface
- Fiber/resin interface delamination
- Corrosion and intermetallic growth at the bondpad under the gold ball bond
- Stress-driven diffusive voiding and hillock formation of Al metallization lines
- Metallization corrosion
- Wirebond fracture
- Passivation cracking
- Delamination at the die/die paddle interface
- Dendritic growth
- Electrostatic discharge/electrical overstress
- Wire fatigue
- Solder fatigue

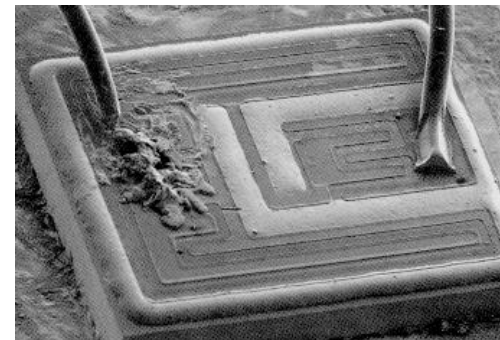
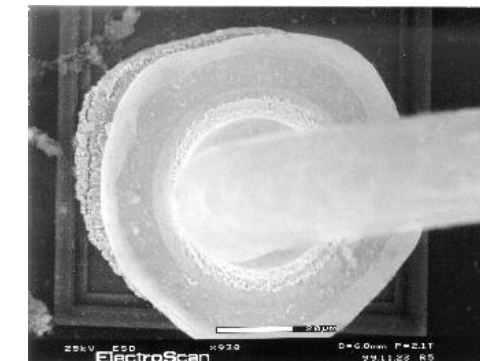
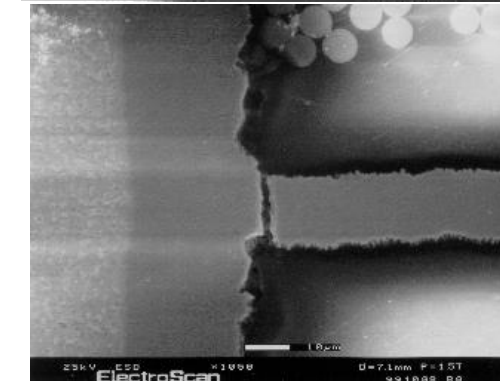
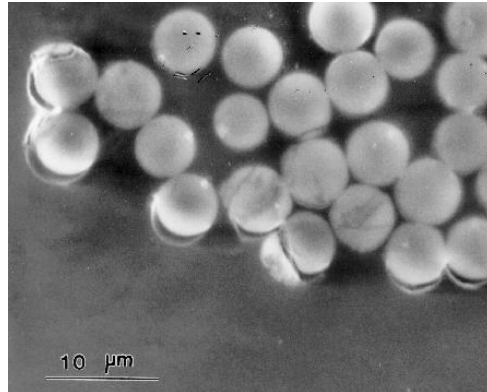
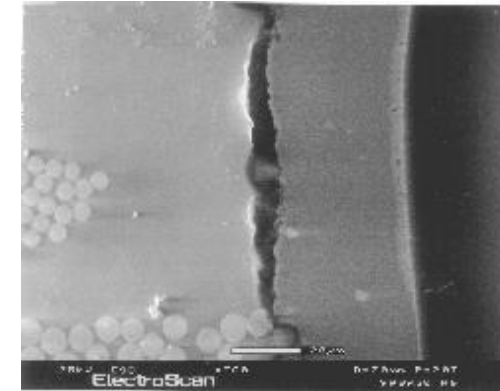
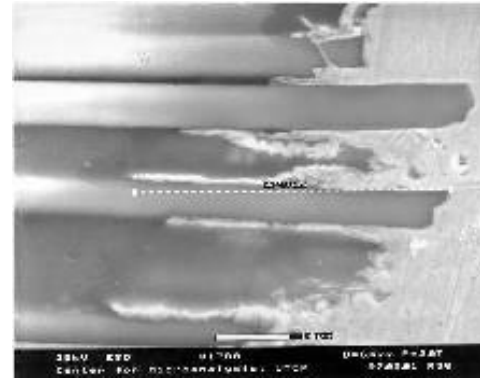

# Applications

- By eliminating the need for a conductive coating, SEM allows imaging of delicate structures and permits subsequent energy-dispersive X-ray spectroscopy (EDS) compositional analysis.
- An ESEM (a variant of SEM) can image wet, dirty, and oily samples. The contaminants do not damage the system or degrade the image quality.
- The ESEM can acquire electron images from samples as hot as 1500°C because the detector is insensitive to heat.
- ESEM can provide materials and microstructural information such as grain size distribution, surface roughness and porosity, particle size, materials homogeneity, and intermetallic distribution.
- ESEM can be used in failure analyses to examine the location of contamination and mechanical damage, provide evidence of electrostatic discharge, and detect microcracks.

# Limitations

- Large samples have to be sectioned to enable viewing in a SEM or an E-SEM, due to the limited size of the sample chamber.
- Only black and white images are obtained. Images can be enhanced with artificial color. Thus, different elements in the same area, having close atomic numbers may not be readily distinguished as in optical viewing.
- Samples viewed at high magnifications for extended periods of time can be damaged by the electron beam (e.g., fiber/resin delamination can be initiated this way).
- Areas having elements with large atomic number differences are not easily viewed simultaneously; increasing the contrast to view the low atomic number element effectively makes the high atomic number element appear white, while decreasing the contrast allows a clear view of the high atomic number element, the image of the low atomic number element is drastically compromised.
- Variations in the controllable pressure and gun voltage can allow samples to appear differently. Lower pressure and voltage give for more surface detail; the same surface can look smoother by just increasing the pressure. Therefore, sample comparisons before and after experiments, especially cleaning treatments should always be examined under the same conditions.
- Image quality is determined by scan rate; the slower the scan rate, the higher the quality. However, at lower scan rates, the image takes a longer time to be fully acquired and displayed. Therefore, sample movement appears visually as jerky motions. A trade off must be made between image quality and visual mobility.

# X-ray Spectroscopy

# Applications

## **X-ray analysis can be used to detect:**

- Surface contamination (chlorine, sulfur)
- Presence of native oxides
- Corrosion
- Concentrations of phosphorus, boron, and arsenic
- Compositional analysis (i.e., Sn to Pb ratio)
- Conductive filament formation
- Intermetallic growth
- Elemental distribution using mapping techniques

# X-ray Mapping

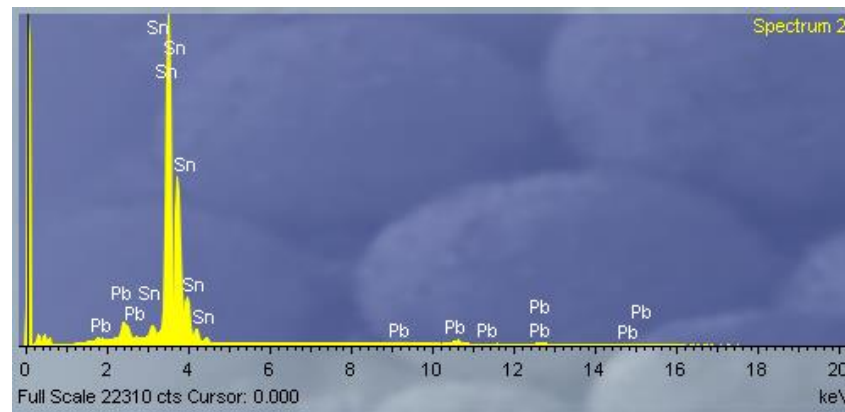
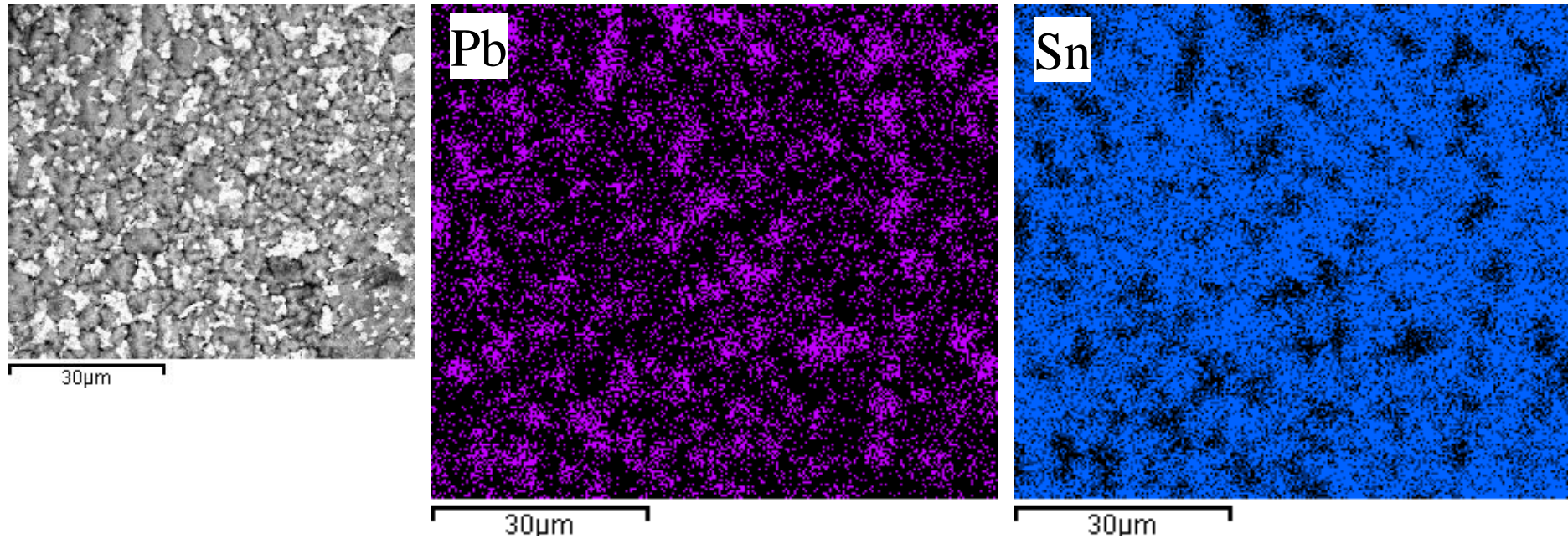

An X-ray mapping of Tin (Sn) distribution (right) and Lead (center) in a eutectic solder. The associated spectrum is shown on left bottom.

# Acquired Spectrum Using EDS

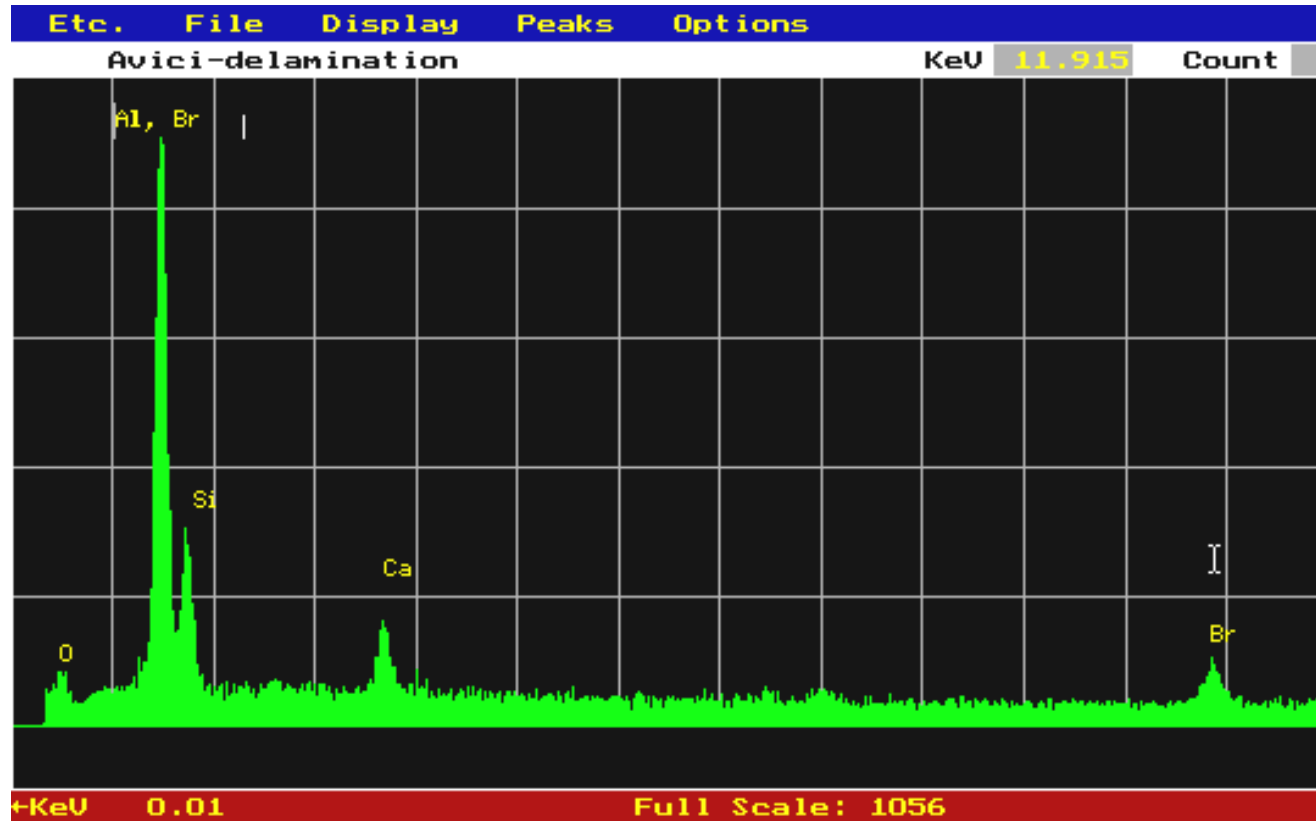

The bromine and aluminum peaks overlap, at 1.481 and 1.487 KeV respectively. It is not clear, using EDS, whether or not aluminum is in this sample. Bromine is present, as evidenced by its second identified peak at 11.91 KeV. The elemental KeV values can be found on most periodic tables.



# Limitations of EDS

- Resolution is limited, therefore it is possible to have uncertainties for overlapping peaks (i.e., tungsten overlap with silicon and lead overlap with sulfur)
- Cannot detect trace elements
- Limited quantitative analysis
- No detection of elements with atomic number  $< 6$
- If a Beryllium window is used, cannot detect light elements such as carbon, nitrogen and oxygen with atomic number  $< 9$
- Specimen must be positioned in such a manner that an unobstructed path exists from the analysis site to the detector.

# Thermal Analysis Techniques

- DSC – Differential Scanning Calorimetry
  - Measures changes in heat capacity
  - Detects transitions
  - Measures Tg, Tm, % crystallinity
- TGA – Thermogravimetric Analysis
  - Measures changes in weight
  - Reports % weight as a function of time and temperature
  - Helps determine composition
- TMA – Thermomechanical Analysis
  - Measures changes in position
  - Detects linear size changes
  - Calculates deflection, CTE, and transition temperature
- DMA – Dynamic Mechanical Analysis
  - Measures changes in stiffness
  - Measure deformation under oscillatory load
  - Determines moduli, damping, and transition temperature

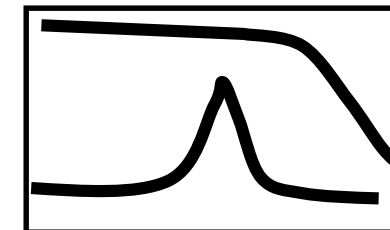
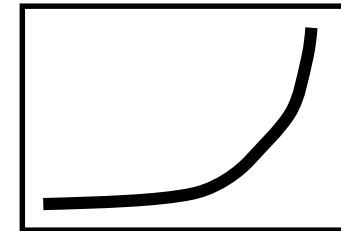
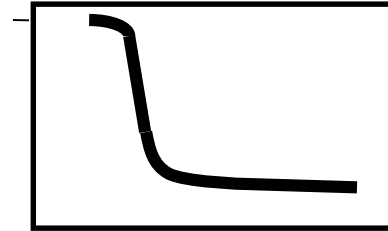
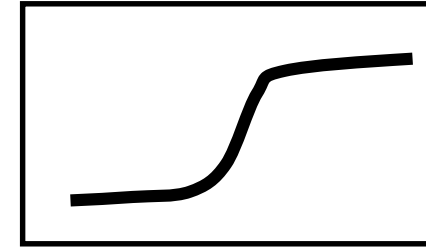

# Thermal Techniques - Use

- All techniques are destructive to the sample
  - Sample will be heated above transitions
  - Will have to be cut to fit in instrument
- All techniques use small samples
  - 10 mg or so for DSC and TGA
  - Samples from 5 to 40 mm long for TMA and DMA



# TMA (Samples A and B)\*

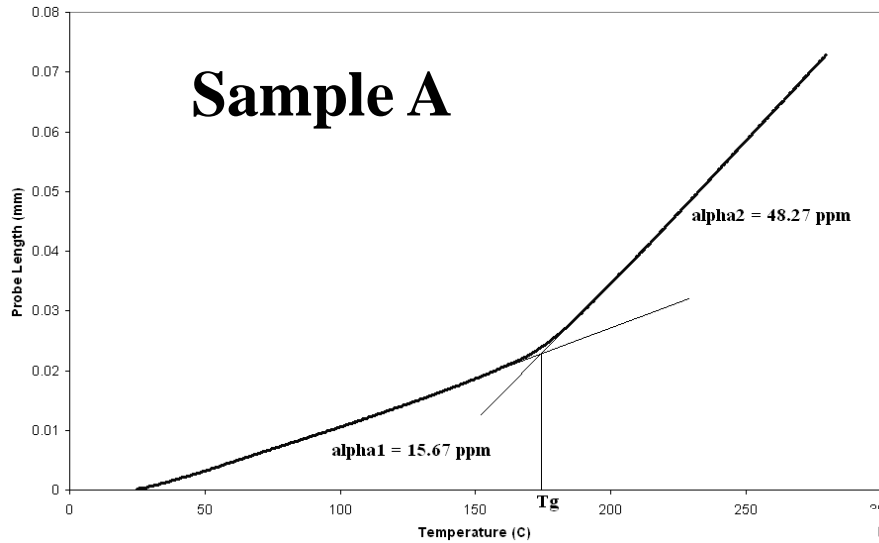

- Coefficient of thermal expansion before glass transition temperature (alpha 1) and after glass transition temperature (alpha 2) is determined.
- Glass transition temperature (Tg) is also determined.

- Constant stylus force applied on the sample: 2 mN.
- Typical scan setup:
- Hold 1 minute at 25 C.
- Heating from 25° C to 280° C at 20° C/minute.

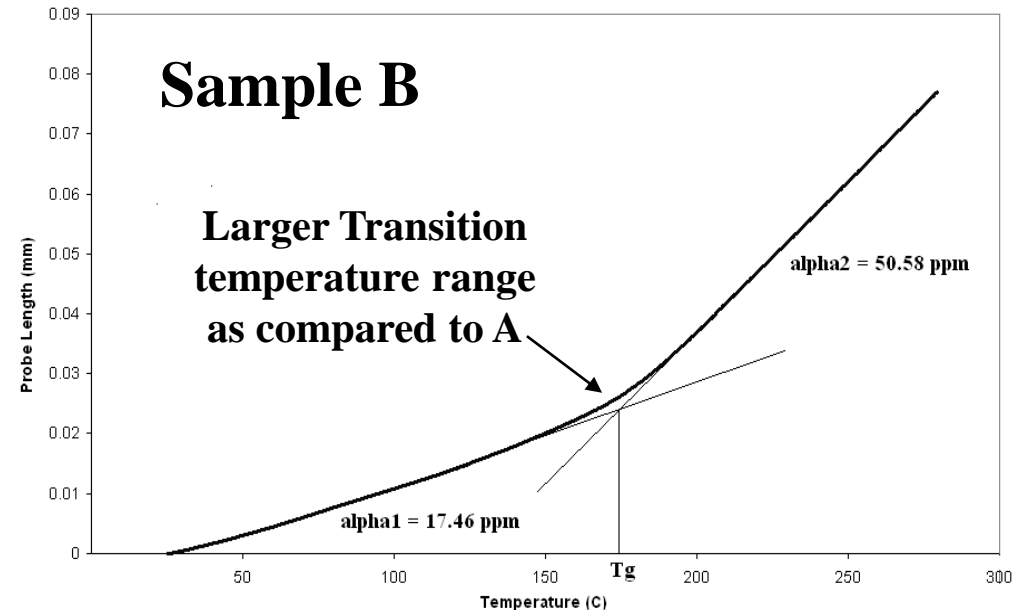

\* - Sample preparation and test refer to IPC TM-650 2.4.24

# Wire Pull, Ball Bond and Solder Ball Shear Testing

# Microtesting Applications

The wirebond pull test is the most widely used method for assessing the quality and degradation of wirebonds and providing assurance that semiconductor devices will not fail in the field due to weak bonds.

The ball bond and solder ball shear tests provide methods for determining interfacial adhesion strength and effects of environmental conditioning or parameter changes, on the shear strength of the ball attachments. Variations in strength from ball to ball on a sample and from batch to batch are also monitored using these methods.

Although a die shear test is not commonly used, deterioration of or flaws in the die attach material can be assessed by this type of shear test.

Devices include:

- Plastic and hermetic packages,
- Multi-chip modules,
- Ball grid arrays, and PWB's used for BGA assembly

# Equipment Overview

Applications include:

- Ball shear, aluminum wedge shear, and low force die shear using up to 5Kg force.
- Die shear testing up to 50Kg force
- Wire-pull testing up to 10Kg force.

## Dage 4000

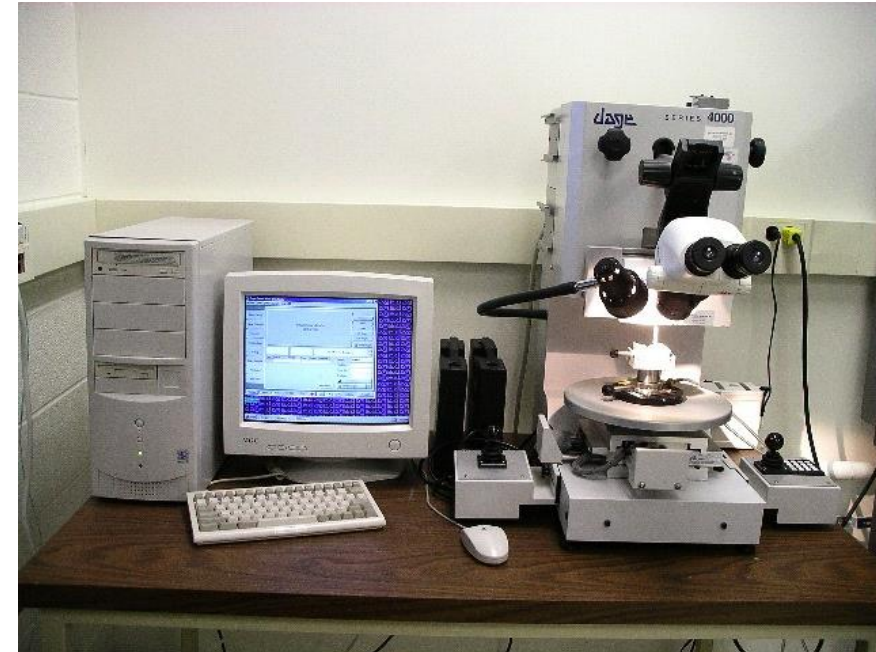

*Ref: nordson.com*

# Wire Pull, Ball Bond and Solder Ball Shear Testing

- Wirebonds interconnect chips, substrates, and output pins.
- Pull test and the ball bond shear test are simple mechanical tests to access the integrity of wirebonds, thereby ensuring reliable operation of electronic components.
- Wirebonds come in various forms, depending on the technique used to create them, and require different means of assessing their integrity.
- Electrical and mechanical attachment from component to substrate can be accomplished through pins, leads or solder ball ball attachments.
- Solder ball shear test allows one to access the effect of parameter changes such as pad plating type, pad geometry, cleaning methods, solder type, and ball size on the strength of the interfacial adhesion.



## Principles of Operation (Wire Pull)

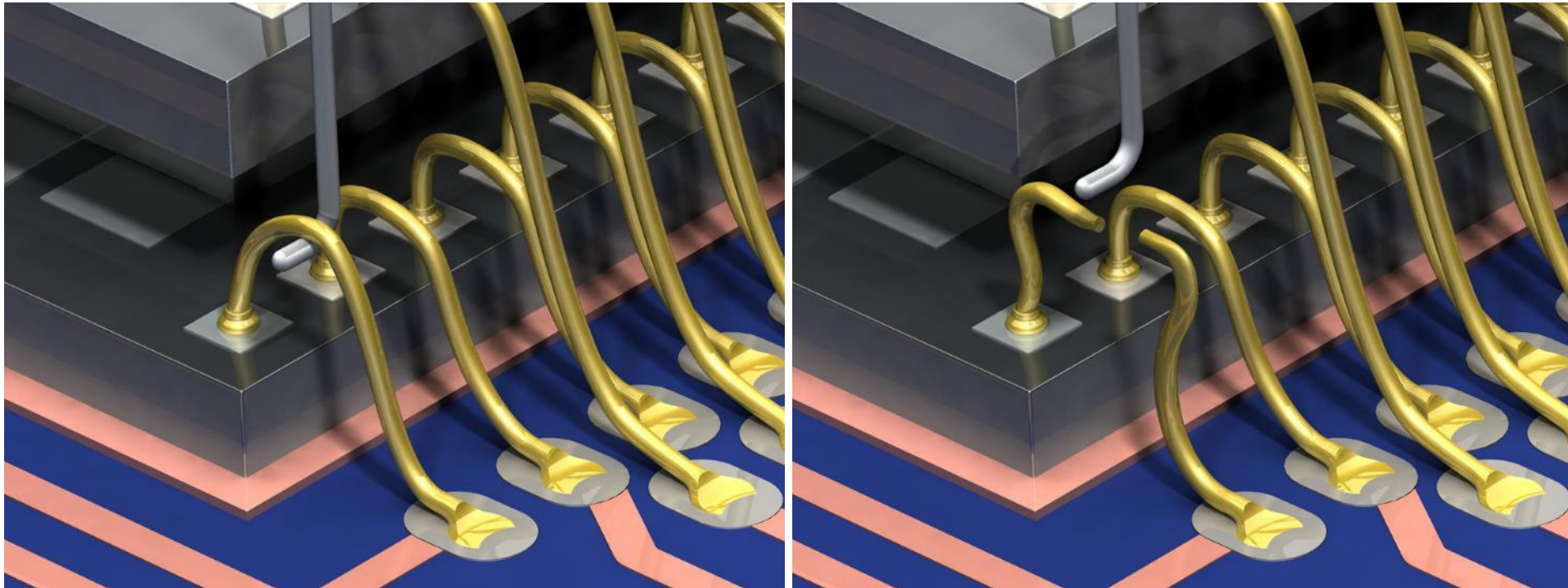

The procedure for obtaining optimal pull test results is as follows:

- Calibrate the equipment.
- Carefully place the hook in the center of the loop.
- Pull straight up, and record the value.

Ref: [https://bondlab-qa.web.cern.ch/bondlab-qa/pull\\_tester.html](https://bondlab-qa.web.cern.ch/bondlab-qa/pull_tester.html)

# Wire Pull limits According to Wire Type and Diameter

(MIL-STD-883E)

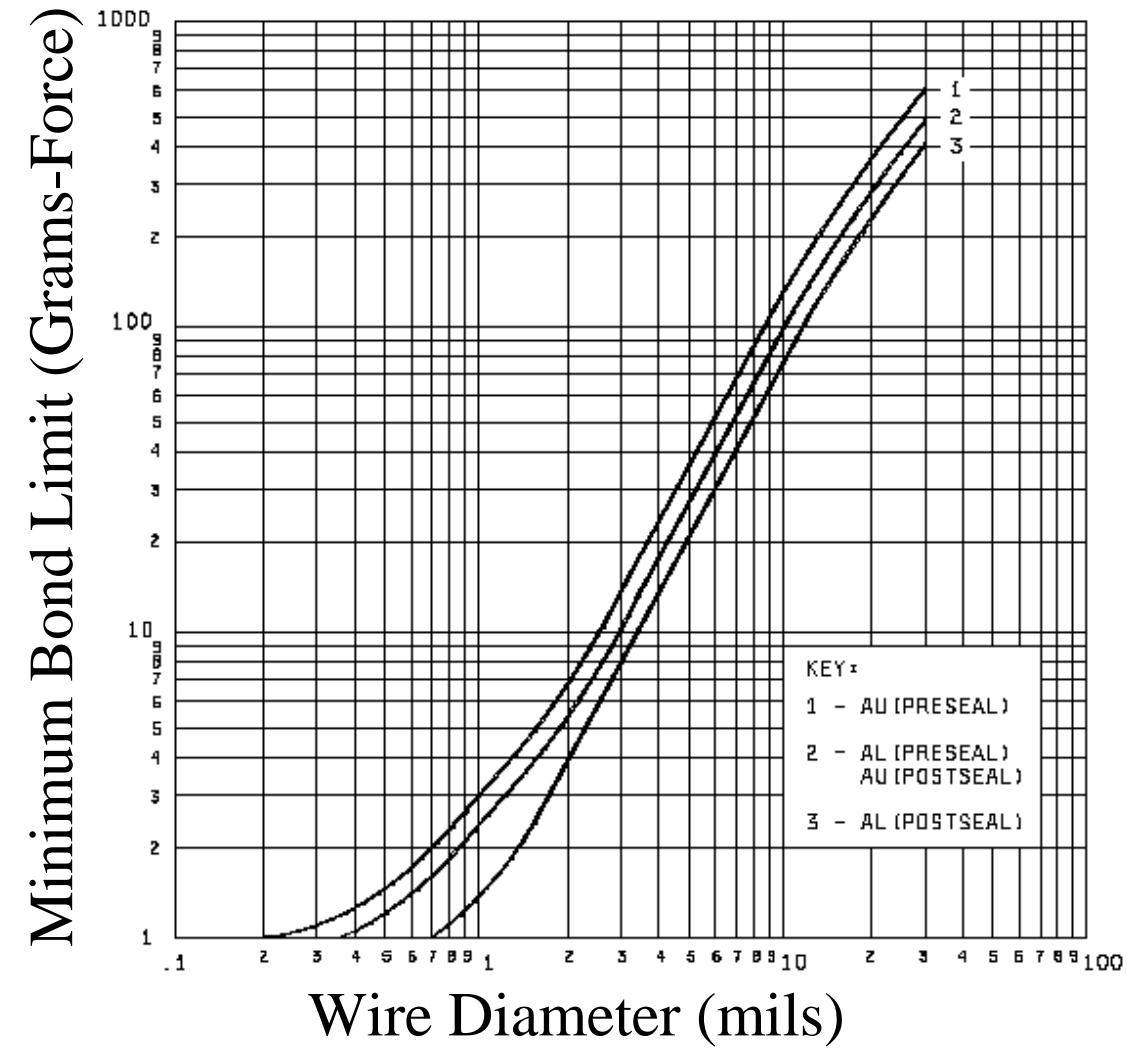

# Ball Bond Shear

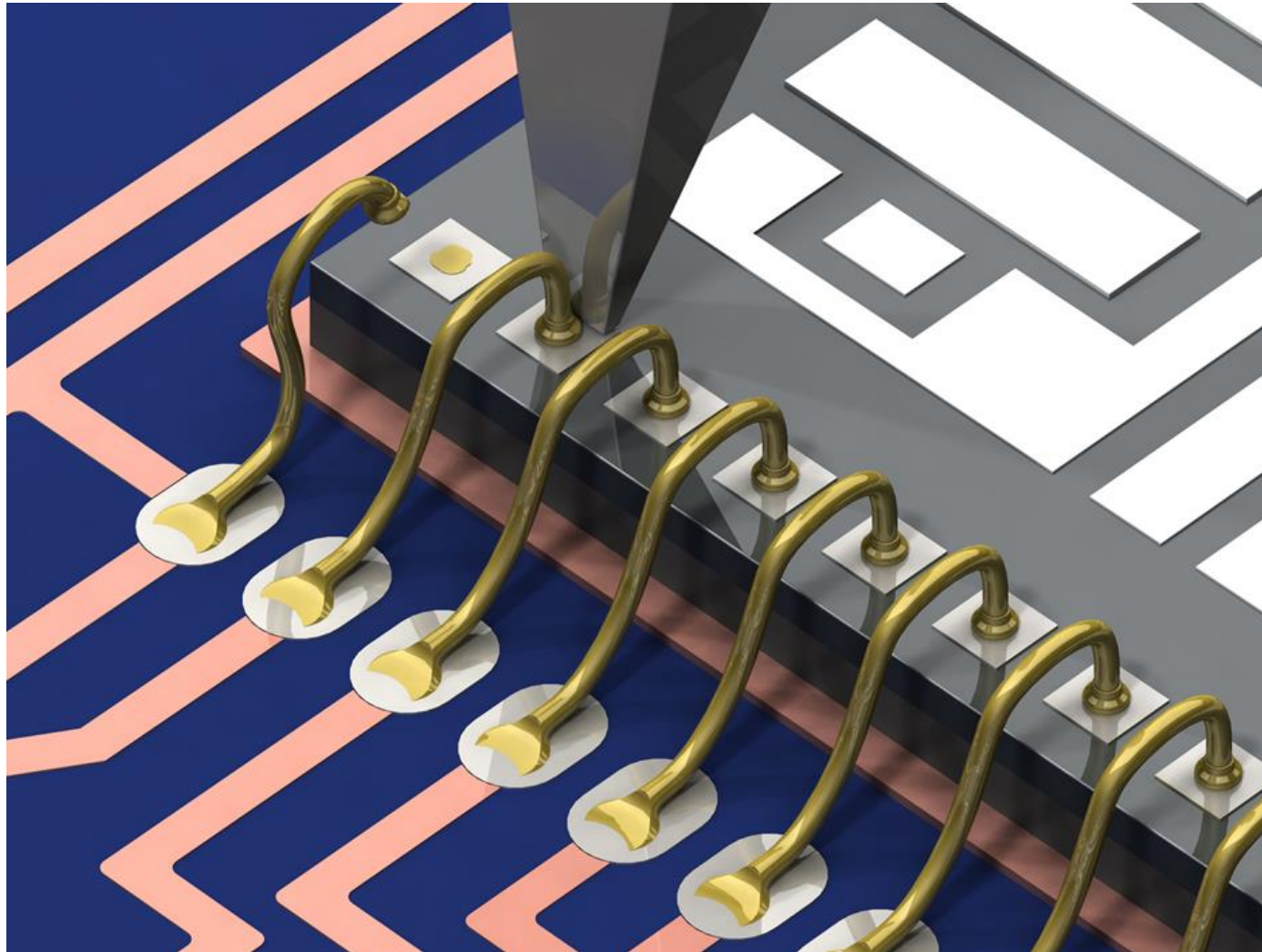

Ref: [https://bondlab-qa.web.cern.ch/bondlab-qa/pull\\_tester.html](https://bondlab-qa.web.cern.ch/bondlab-qa/pull_tester.html)

# Ball Bond Shear Modes

Type 1: Ball Lift

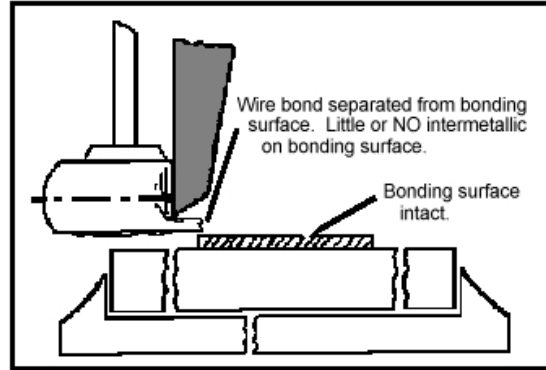

Type 2: Ball Shear  
 – Au/Al

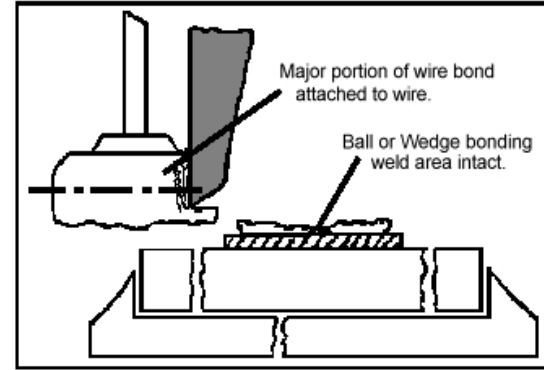

Type 3: Cratering

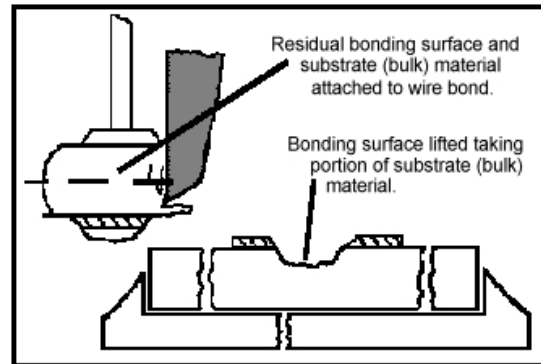

Type 4: Bond Pad Lift

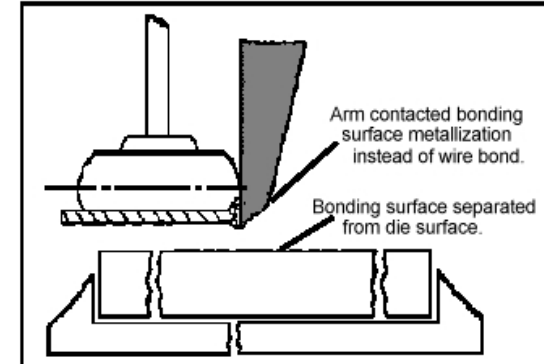

Type 5: Wire Shear

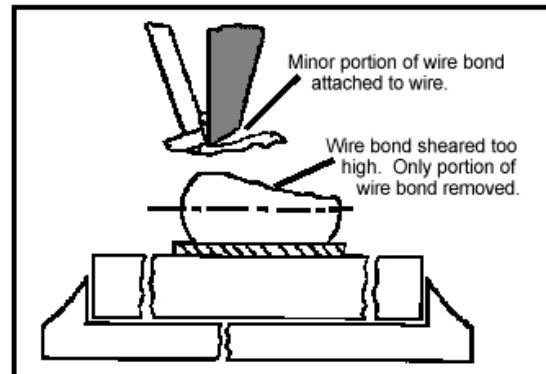

Type 6: Bond Surface Lift

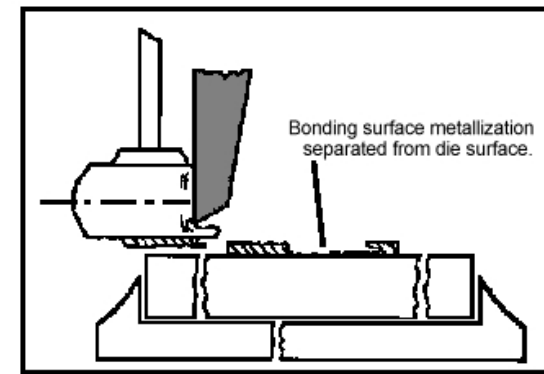

Ref: [jedec.org](http://jedec.org)

# Minimum Shear Values

(JEDEC Standard 22-B116)

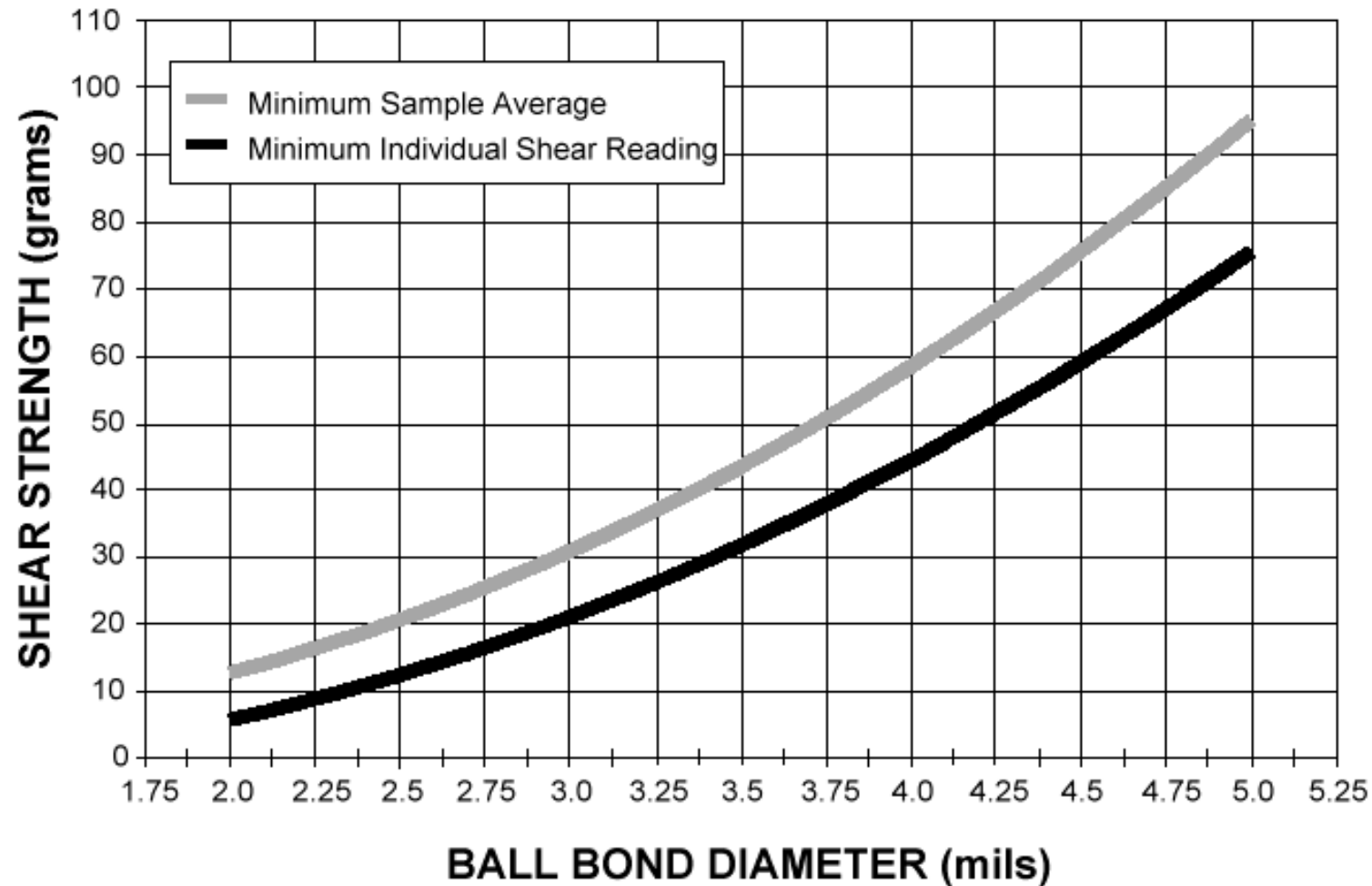

# Ball Shear and Cold Bump Pull Tests

- Ball shear test and cold bump pull test are destructive tests conducted to determine solder ball attachment strength of Ball Grid Array (BGA) packages.
- Both ball shear test and cold bump pull test are quality evaluation test of BGA components.
- A substantial amount of literature has focused on the ball shear test on BGA components. Not much literature addressed on cold bump pull tests.

# Ball Shear Test

- Ball shear test is a destructive test conducted to determine the ability of Ball Grid Array (BGA) solder balls to withstand mechanical shear forces. This test represents possible applied force during device manufacturing, handling, test, shipment and end-use condition.
- The industry standard used to conduct this test is: JEDEC JESD22-B117A (October, 2006)
- IPC-9701 also mentions the solder shear test.

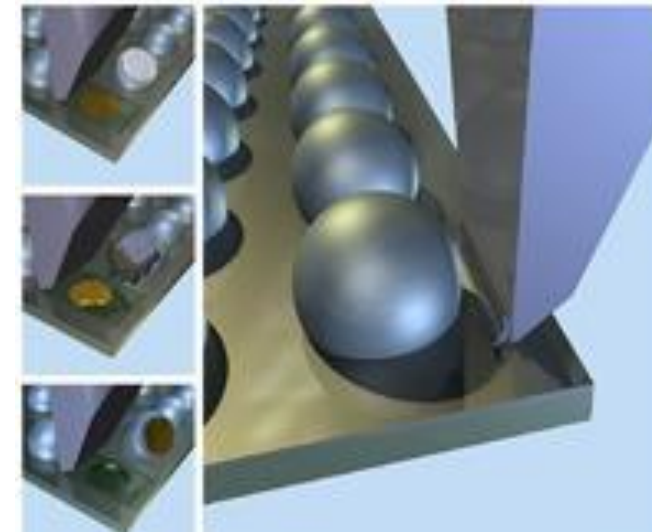

*Ref: solder Ball Shear, JESD22-B117A*

# Ball Shear Tool to Solder Ball Alignment

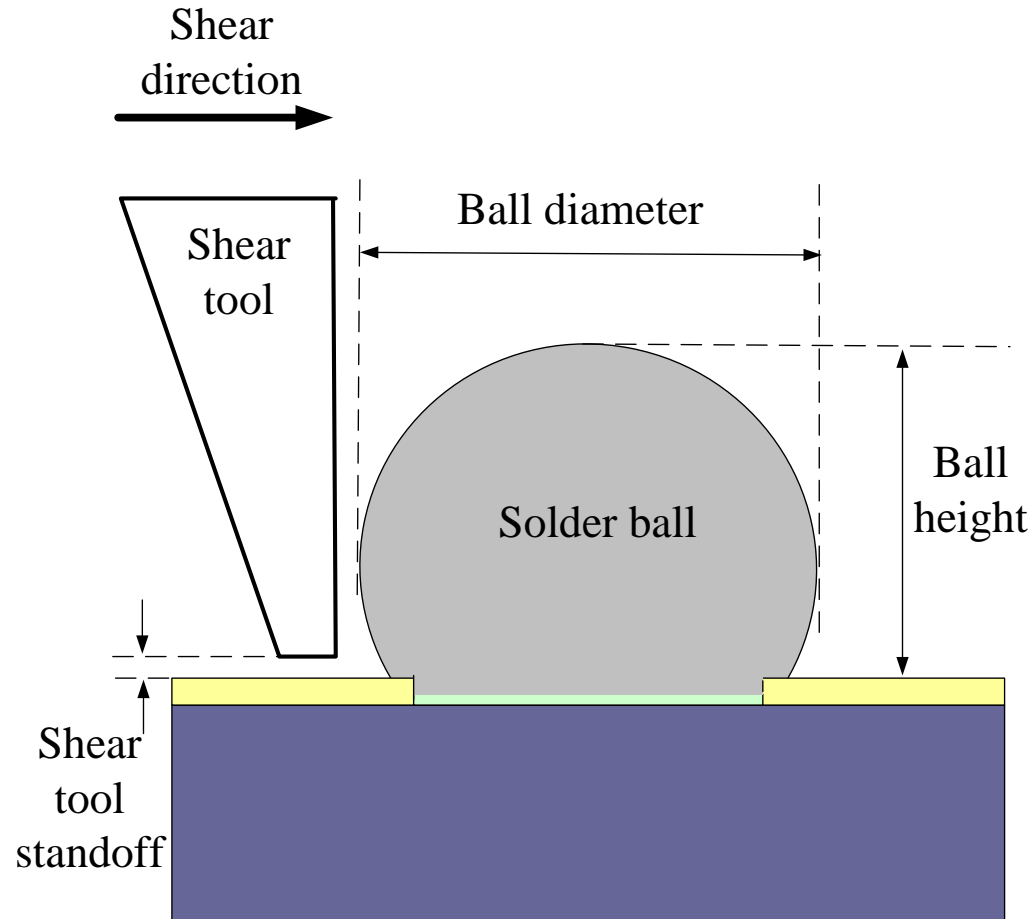

Shear tool standoff is the distance between the device planar surface and the shear tool tip. In JESD22-B117A, the shear tool standoff should be no greater than 25% (10% preferred) of the solder ball height. In IPC-9701, the shear tool standoff should be at least 50  $\mu\text{m}$ .

*Ref: solder Ball Shear, JESD22-B117A*



# Failure Modes of Ball Shear Test

- Ductile – Solder ball fracture at or above the surface of the solder mask within the bulk solder material.
- Pad Lift – Solder pad lifts with solder ball; lifted pad may include ruptured based material.

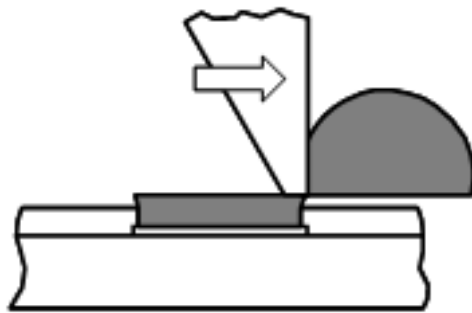

Ductile

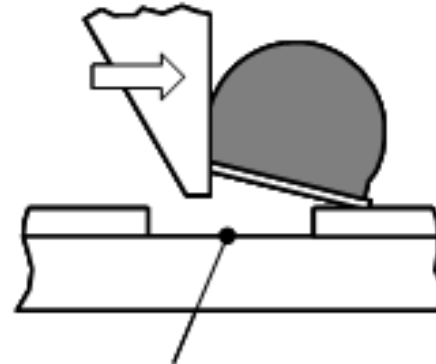

Pad separation at  
base material

or

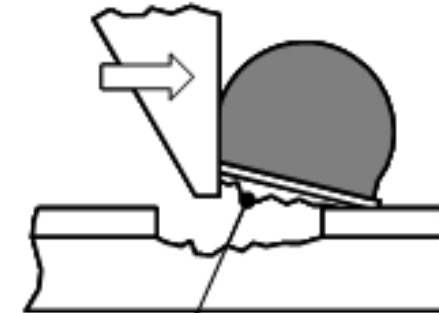

Lifted pad includes  
ruptured base material

Pad Lift

*Ref: solder Ball Shear, JESD22-B117A*

# Failure Modes of Ball Shear Test (Cont.)

- Ball Lift – Solder ball lifts from pad; pad is not completely covered by solder/intermetallic and the top surface of the pad plating is exposed.
- Interfacial Break – The break is at the solder/intermetallic interface or intermetallic/base metal interface. The interfacial fracture may extend across the entire pad or be the dominant failure mode at the tool contact region.

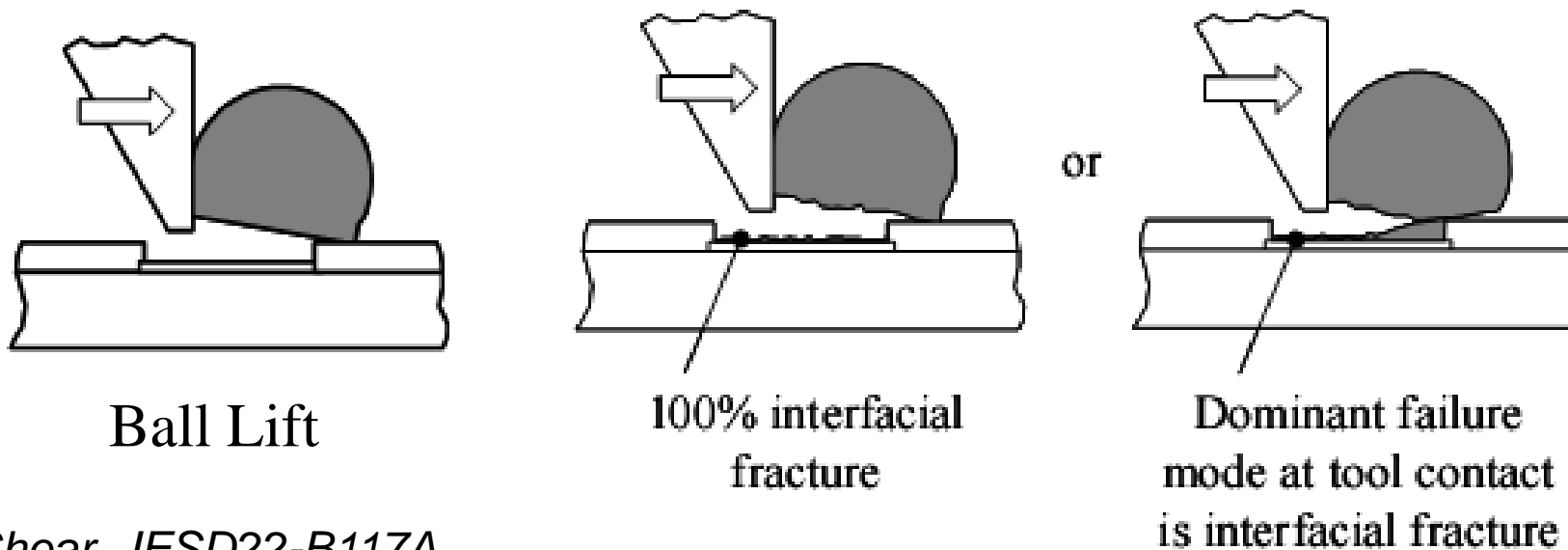

Ref: solder Ball Shear, JESD22-B117A

# Cold Bump Pull Test Setup

- Cold bump pull (CBP) test is an alternative to the traditional ball shear testing method for characterizing the attachment strength of solder interconnection.
- CBP testing helps in evaluation of interface of all types of bumps. JEITA EIAJ ET-7407 outlines the method for cold ball pull testing.

## Test setup

- Equipment: DAGE 4000, load cell: CBP/TP 5Kg
- Jaw close time: 1.8 sec
- Pull speeds: 500 $\mu$ m/sec and 5000 $\mu$ m/sec

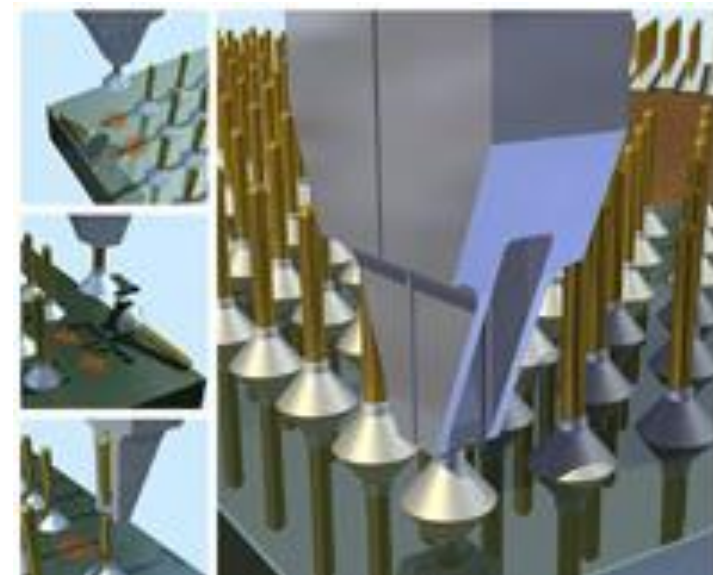
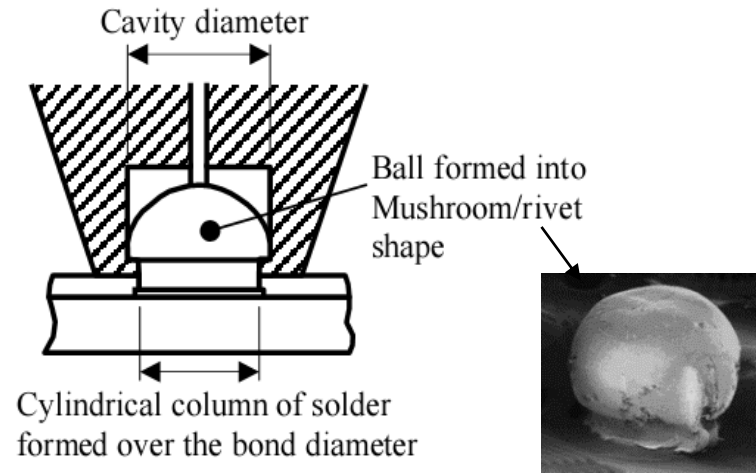

Ref: [nordson.com](http://nordson.com) and EIAJ ED-4702A

# Failure Modes

- Ball failure
  - Solder ball failure in the bulk solder materials.
- Pad failure
  - The pad peels off of the substrate or fractures in the substrate materials.
  - Possible pad design problem may lead to this failure.

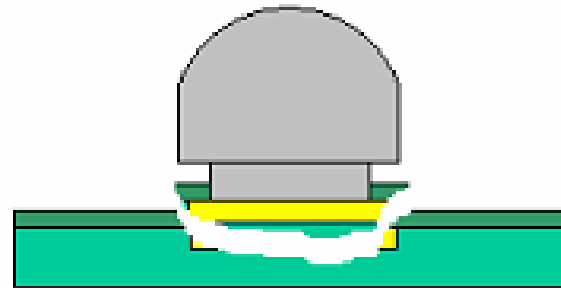
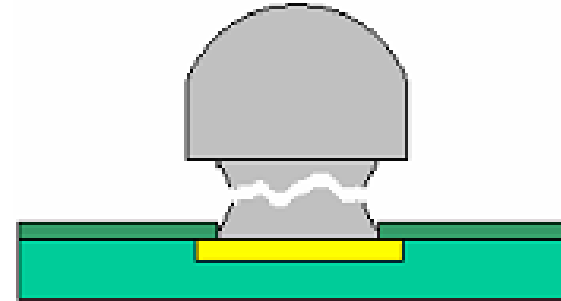

Ref: [nordson.com](http://nordson.com) and EIAJ ED-4702A

## Failure Modes (Cont.)

- Bond failure
  - Failure occurs when the separation is at the interface of the solder and the pad.
  - Possible process or material problems may lead to this failure.
- Ball extruded
  - Failure occurs when the ball deforms into a cylinder shape due to the jaws pulling away excess solder without producing a bulk solder failure.
  - Setup of the pull test has a problem or the solder material is very soft.

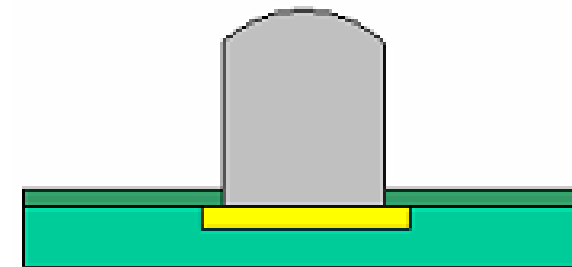
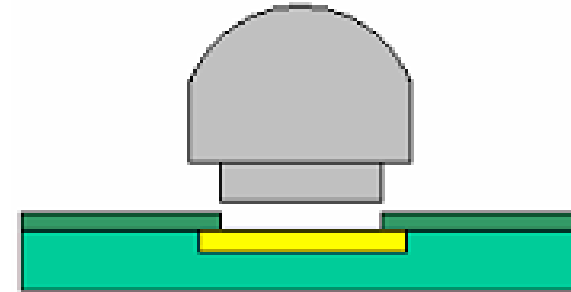

Ref: [nordson.com](http://nordson.com) and EIAJ ED-4702A

# Limitations of the Techniques

As applied to degradation analysis, both the wire-pull test and the ball bond shear test are destructive, since the package has to be decapsulated or delidded and the wire/ball bonds broken.

Only in cases of catastrophic failure, such as low-temperature impurity-driven intermetallic growth, will the destructive wirebond pull test yield information other than the relative breaking strength of the wire at the weakened neck area. Thus, it has to be supplanted by the ball bond shear test.

The presence of intermetallics provides a site for fatigue crack initiation. However, since the intermetallics are much stronger than both the gold and aluminum, the ball bond shear strength need not be lowered when they are present, and could be missed by a ball shear test. In such cases, where electrical resistances could increase along with ball bond shear strength in the early stages of intermetallic growth, other evaluation techniques are necessary.

*Ref: nordson.com and EIAJ ED-4702A*

# Limitations of the Techniques

Varying parameters such as shearing tool velocity, height, planarity of surface, wire pull test speed or angle could all affect resulting data; for relative comparisons, all parameters should be kept constant.

Only by using a microscope attachment and visually monitoring every test from start to end, will reliable results be obtained. When the shear test is initiated, the shear tool automatically moves up to a preset height and then shearing is initiated. If the tool scrapes on debris or an uneven surface while shearing the ball, the resulting shear strength may be too high.

# Metallographic Sample Preparation\*

\*- Adapted from Buehler Limited/ITW



# What Is Micro-sectioning of Printed Circuit Board?

Technique used to evaluate printed wiring board quality by exposing a cross-section at a selected plane such as

- **Plated through-holes**
- Plating thickness
- Via
- **Soldered connections**
- Delamination in PCB
- **Inner layer connections**

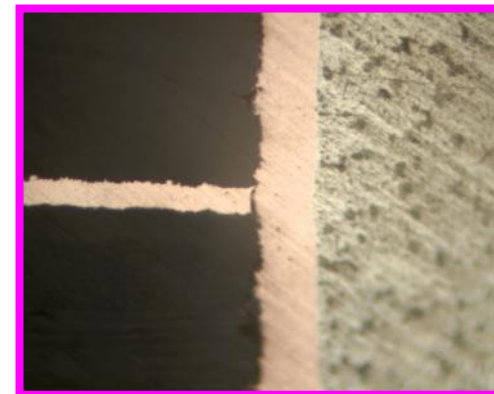
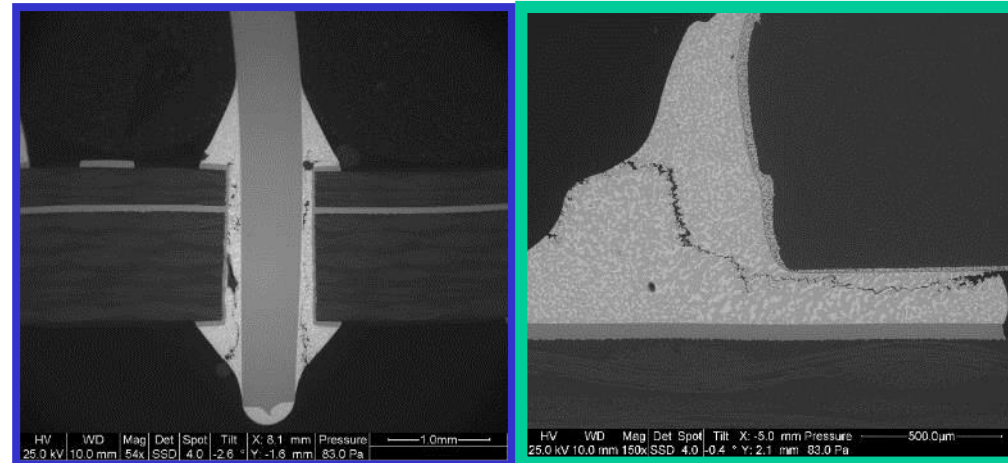

# Primary Purpose of Micro-sectioning

- To monitor the processes rather than to perform final inspection because it makes no sense to add value to a product that is already rejectable!
- Therefore, the objective is to detect any deviations from normal in the manufacturing processes as early as possible to avoid adding value to a defective product. Corrections to the process should then be made as soon as possible.

# Goal of Specimen Preparation

Reveal the true microstructure of all materials

- Induce no defects during specimen preparation
- Obtain reproducible results
- Use the least number of steps in the shortest time possible
- Achieve a cost effective operation

# Preparation Steps

*‘Each step is equally important’*

- Documentation
- Sectioning
- Mounting
- Grinding and Polishing
- Visual Examination
- Etching
- Analysis

# Documentation

- Process data: vendor, material, batch #, part #, sampling
- Description of specimen orientation, location, cut area, Macro image
- Type of analysis and defect, area of interest
- Record mounting, polishing, etching parameters
- Record microstructure data: inclusions, porosity, grain size, etc.

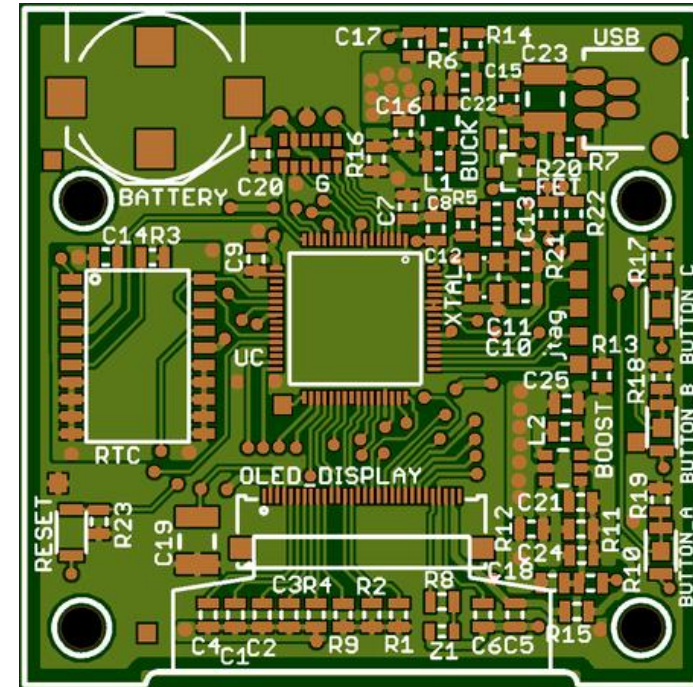

# Sectioning

- Equipment
- Blade, wheel (SiC, alumina, diamond)
- Load
- Blade RPM
- Feed rate
- Coolant
- Delicate materials may require encapsulation or chuck padding for holding

# Methods

| Method                       | Comments  |
|------------------------------|---|
| Shearing                     | Severe torsion damage to an undetermined distance adjacent to the cutting edges   |
| Hollow punch<br>(Saved hole) | Convenient, and rapid but limited to boards 0.08” thick or less   |
| Routing                      | Rapid and versatile with moderate damage but noisy and hard to control.   |
| Band saw                     | Rapid, convenient moderate damage and easy to control when a 24-32 pitch blade is used at 3500-4500 ft./min.  |
| Low speed saw                | Least damage of any method allowing cuts to be made even into the edge of the plated through-hole barrel. However, it is too slow for high volume micro-sectioning. |
| Precision table saw          | Least destructive method of removing specimens from component mounted boards for soldered connection analysis   |

# Sectioning damage

| <b>Method</b>  | <b>Type of damage</b>                             | <b>Possible depth</b> |
|--|---|-----------------------|
| <b>Shearing</b>                                      | <b>Deep mechanical damage</b>                     | <b>5 mm</b>           |
| <b>Band / hack saw<br/>lubricated not<br/>cooled</b> | <b>Moderate thermal and<br/>mechanical damage</b> | <b>2.5 mm</b>         |
| <b>Dry abrasive<br/>cutting</b>                      | <b>Moderate to severe thermal<br/>damage</b>      | <b>1.5 mm</b>         |
| <b>Wet abrasive cut-<br/>off saw</b>                 | <b>Minimal thermal and<br/>mechanical damage</b>  | <b>250 μm</b>         |
| <b>Diamond /<br/>precision saw</b>                   | <b>Minimal thermal and<br/>mechanical damage</b>  | <b>50 μm</b>          |



# Mounting Principles

- Sample encapsulated in epoxy, acrylic or other compound
- Sample edges protected during polishing process
- Delicate samples protected from breakage
- Smooth mount edges increase life of polishing surfaces
- Allows automation and ability to prepare multiple samples simultaneously
- Uniform pressure on mount maximizes surface flatness
- Safety

# Mounting Method Selection

## Castable (cold) mounting

- Resin/hardener selection
- Vacuum
- Additives for edges, conductivity

## Compression (hot) mounting

- Compound selection
- Pressure
- Heat

## Specimen characteristics to consider:

- Softening/melting temperature
- Sample thickness, ability to withstand pressure
- Brittleness, friability
- Porosity
- Hardness & abrasion resistance relative to mounting compound
- Importance of edge retention

# Potting Compounds

## Resin of Choice?...EPOXY!

- **Low shrinkage and moderate hardness are important for microelectronics.**
  - **Less surface relief**
  - **Better edge protection**
- **Uncured epoxy typically has low viscosity for filling small cavities.**
- **Epoxy can be cast while under vacuum. This enhances its cavity filling ability.**

# Damage

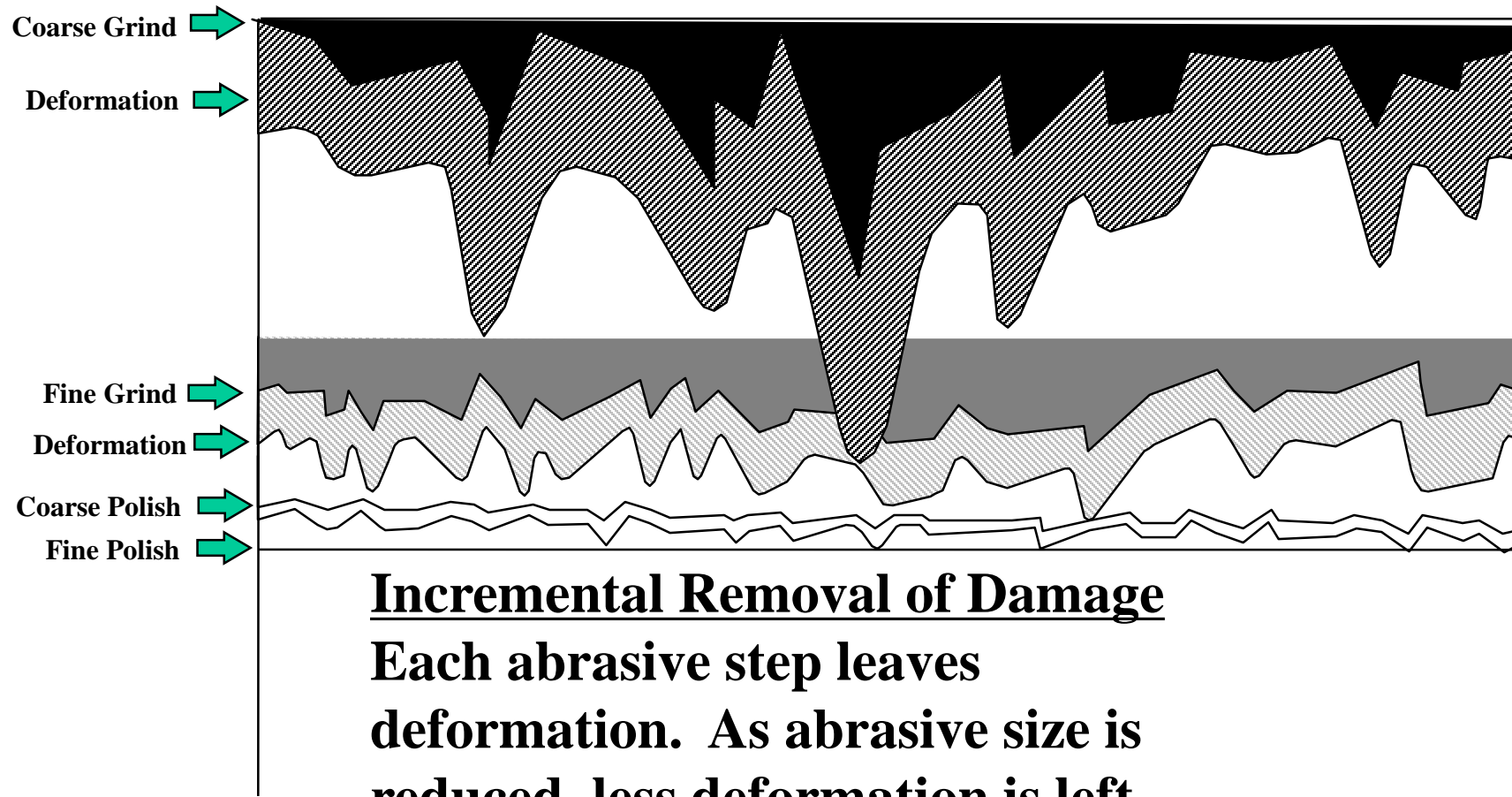

**Incremental Removal of Damage**  
Each abrasive step leaves deformation. As abrasive size is reduced, less deformation is left behind.

# Grinding Steps

- The initial grinding surface depends on the condition of the cut surface – more damaged surfaces require coarser first-step grinding
- For excessive damage, re-sectioning with an abrasive or precision saw is recommended
- A single grinding step is adequate for most materials sectioned with an abrasive or precision saw
- Softer materials require multiple grinding steps and smaller abrasive size increments
- Remove damage with progressively smaller abrasive particle sizes
- With decreasing particle size:
  1. Depth of damage decreases
  2. Removal rate decreases
  3. Finer scratch patterns emerge

# Polishing Principles

- Further refinement of ground surface using resilient cloth surfaces charged with abrasive particles
- Depending on material characteristics, cloth selected may be woven, pressed or napped
- Commonly used abrasives are diamond and alumina
- The polishing process consists of one to three steps that:
  1. Remove damage from the last grinding step
  2. Produce progressively finer scratches & lesser depth of damage
  3. Maintain edges and flatness
  4. Keep artifacts to an absolute minimum

# Time

- Each step must remove the surface scratches and sub-surface deformation from the previous step
- Increase time to increase material removal
- Smaller increments in abrasive size require shorter times at each step
- Increases in surface area may require longer times
- Too long times on certain cloths can produce edge rounding and relief

# Additional Considerations

- Bevel mount edges to increase cloth life
- Clean specimens and holder between steps to prevent cross contamination of abrasives
- Ultrasonic cleaning may be required for cracked or porous specimens
- Dry thoroughly with an alcohol spray and a warm air flow to eliminate staining artifacts
- Remove polishing debris by rinsing cloth surface after use to increase cloth life



# Final Polishing Principles

- Removes remaining scratches, artifacts and smear
- Produces a lustrous, damage-free surface
- Maintains edge retention
- Prevents relief in multiphase materials

# Etching Principles

- Etching is a process of controlled corrosion
- Selective dissolution of components at different rates reveals the microstructure
- Completion of etching is determined better by close observation than timing
- Etching is best performed on a freshly polished surface before a passive layer can form
- A dry surface produces a clearer etched structure than a wet one
- An under-etched surface may be re-etched but an over-etched surface requires re-polishing

# Etching Techniques

- Immersion – sample immersed directly into etchant solution
  - Most commonly used method
  - Requires gentle agitation to remove reaction products
- Swab – polished surface swabbed with cotton ball soaked with etchant
  - Preferred method for materials in which staining is a problem
- Electrolytic – chemical action supplemented with electric current
  - Attack controlled by chemical selection, time, amps

# PWB Etchants (For Copper)

- Equal parts 3% H<sub>2</sub>O<sub>2</sub> and ammonium hydroxide, swab for 3 to 10 seconds, use fresh etchant to reveal grain boundaries of plating and cladding copper material.
- 5 g Fe(NO<sub>3</sub>)<sub>3</sub>, 25 mL HCl, 70 mL water, immerse 10 – 30 seconds, reveals grain boundaries very well.

# Decapsulation of Plastic Packages\*

Decapsulation is the removal of the encapsulant from a plastic encapsulated microcircuit (PEM) to expose the die and the interconnects for failure examination with the aid of other techniques, such as optical microscopy, electron microscopy, energy dispersive X-ray spectroscopy, and ball-bond and die shear and wire pull testing.

Decapsulation can be accomplished by any of three methods:

1. Mechanical Decapsulation
2. Chemical Decapsulation
  - Manually
  - Automated
3. Plasma Etching

\* - images courtesy of Nisene

# Important – Laboratory Safety

- **Chemical**
  - Clean up Spills
  - Label
  - MSDS
  - Safe Disposal
- **Personal protection equipment**
  - Safety glasses / goggles
  - Gloves
  - Apron
- **Facility**
  - Hood
  - Eyewash
  - Shower

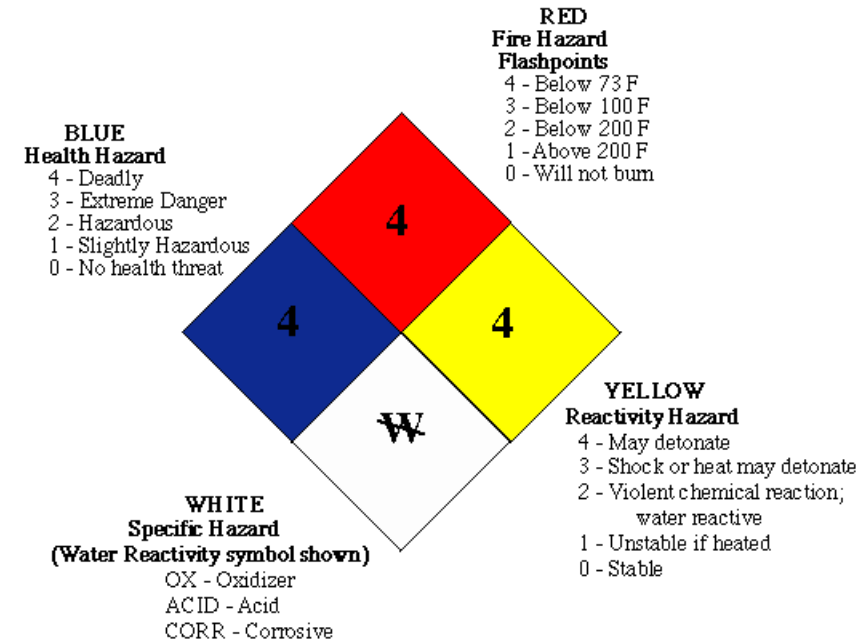

# Chemical Decapsulation (Manual)

## Manual Decapsulation Procedure

1. Using a drill press and the milling tool bit (about half of the width of the plastic package), drill a cylindrical hole from the top center of the plastic package. The depth of the hole should be about one-third of the package thickness. (It is not advisable to use a regular drill bit in place of a milling tool because the resulting conical hole is undesirable.)
2. Place the drilled package on a scrap metal plate and heat it on a hot plate to about 80°C.
3. While the package is being heated, prepare a squeeze bottle of acetone and a small amount (~5 ml) of red fuming nitric acid in a small glass beaker.
4. Using a Pasteur pipette, drop 1 to 2 drops of red fuming nitric acid in the hole of the heated package. Rinse away the dissolved plastic with acetone in a waste glass beaker after the fumes die away. Repeat until the microcircuit is exposed.

# Automatic Chemical Decapsulation\*

- Does every part use the same "recipe"?
  - No. While groups of parts may have similar recipes, you will have to adjust recipe to meet the requirements of your sample.
- Decapsulation times can vary depending on the thickness of encapsulant, package size (length and width), and ease of encapsulant removal.
  - General rule: the thicker the part (i.e. the more plastic), the longer the etch time.
  - Some samples, such as BGAs manufactured in the late 1990s/early 2000s, will require a high temperature sulfuric acid as the etchant.
- Other etch parameters may also be affected by the characteristics of the device to be etched. Example include:
  - Whether the sample has been "burned in"
  - Samples with heatsinks
- Nitric acid is the recommended acid to start with on all parts; however, use sulfuric acid as well.

Ref: [nisene.com](http://nisene.com)



# Example of a “stack-up”

## A Typical Monolithic Gasket Stack-up

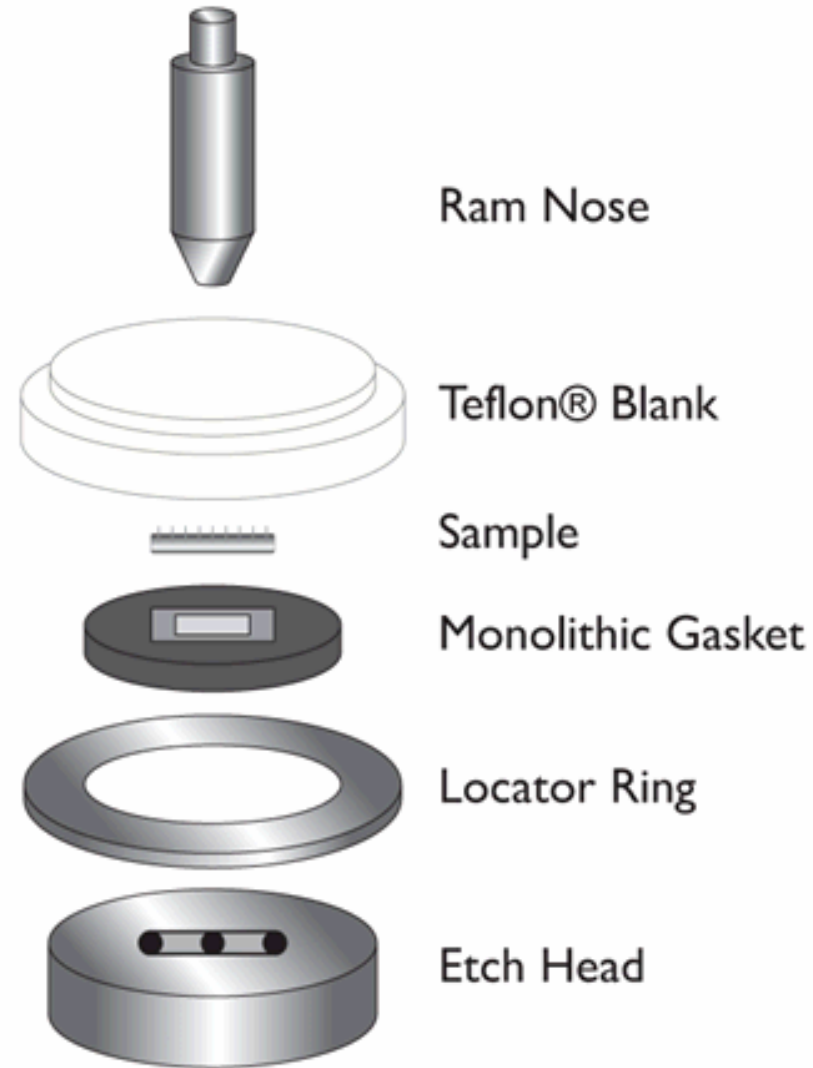

# Chemical Decapsulation – Die Size

- Die size can be determined two ways:

## **X-ray part to determine die size**

- Set the sample on the X-ray stage and capture the image using image-capturing software.
- Print the captured image at a 1:1 ratio and make measurement of the die within the package.
- Select the appropriate gasket based on the dimensions.

## **Start with small decapsulation hole in your gasket and work out if too small**

- Select a gasket with a small aperture that is obviously smaller than the die.
- Etch the sample until you start to see the surface of the die.
- Continue to etch outward toward the edge of the die until all sides are exposed (if desired for your application).
- Select new gasket based on the size of the die. This can be done by visual approximation (“eyeballing”), but exact measurements may be taken at this step if desired.

- X-ray provides a quicker method of determining die size, since this information is available immediately; however, not all facilities have x-ray on site.

# Limitations

- Chemical decap only works for plastic-encapsulated parts (and other similar epoxies).
- Mechanical decap is used for ceramic parts.
- Some parts contain passivation layers over the die. In some cases, the decapsulation process ceases here and further chemical removal techniques may need to be employed.
- Heatsinks must be removed prior to decap. Decapsulation does not etch (most) metals.
- Samples with copper wiring require more trial and error before finding a proper set of etch parameters, but tend to be very uncommon in the counterfeit distribution world.

# Post-Decap Inspection Criteria

- Overview optical image of the decapsulated device.
- Higher magnification image (min 500X) showing only the die. Attributes to document:
  - Manufacturer markings
  - Name
  - Logo
  - Unique image
  - Die part numbers
  - Die mask ID numbers
  - Year of design
  - Number of metal layers
  - Pin 1 bond pad outline
  - Bond wire material
  - Bond wire diameter
  - Bond types
    - Thermal sonic
    - Crescent with or without safety bonds
    - Ultrasonic bonds
    - Compound bonds

# Decapsulated Part Inspection



1x Magnification:  
Before Decapsulation

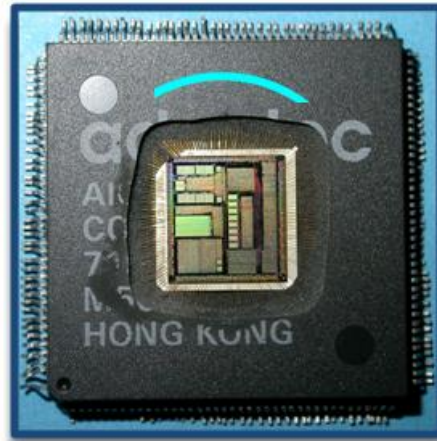

1x Magnification:  
After Decapsulation\*

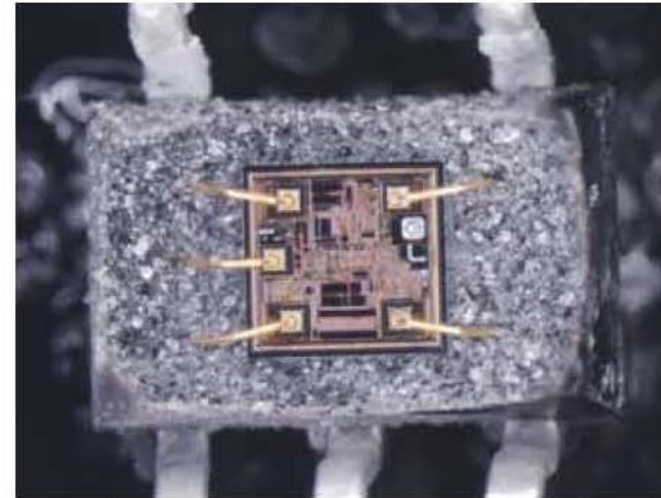

Optical images of a decapsulated part

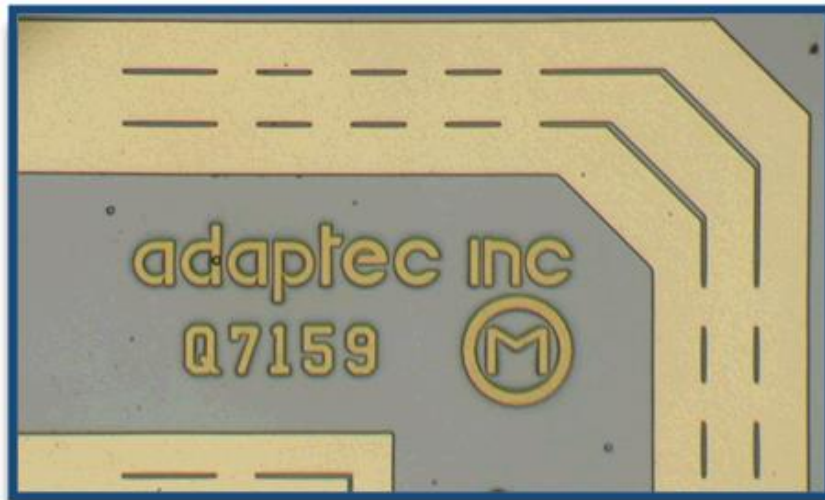

Showing logo identification\*

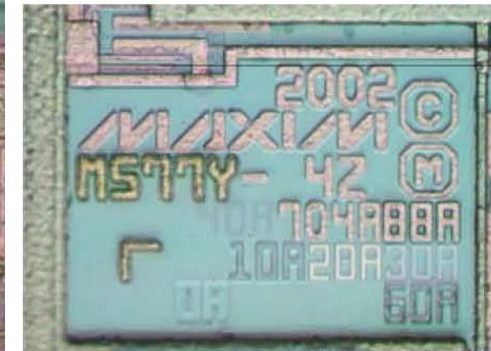

# Fairchild 20L PLCC Dual Ultra-fast Voltage Comparator



External Optical Image

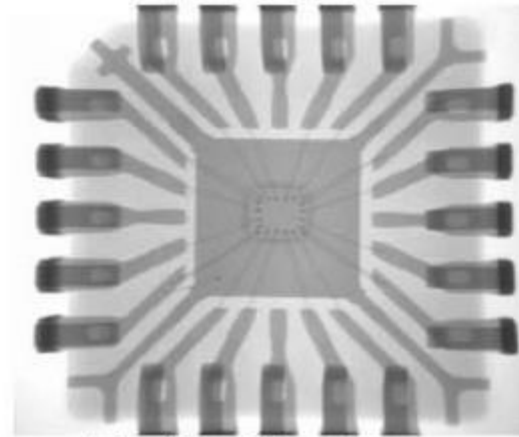

Top View X-ray Image

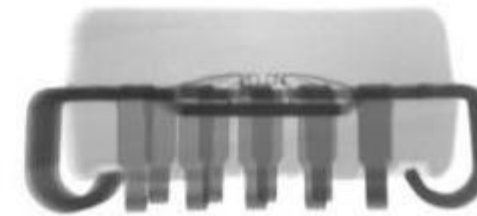

Side View X-ray Image

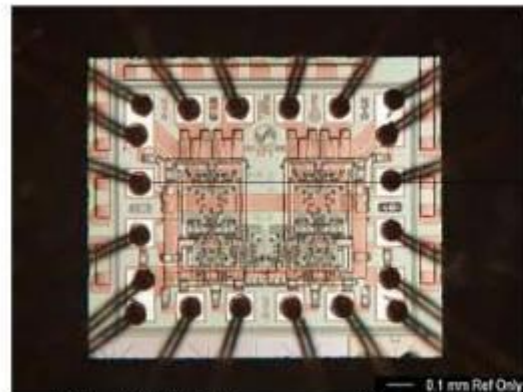

Brightfield Image of the Die

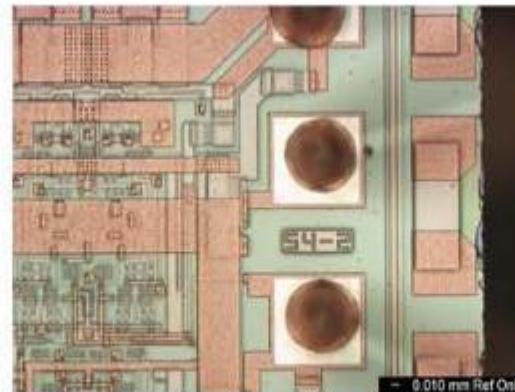

Photo Showing a Part Marking

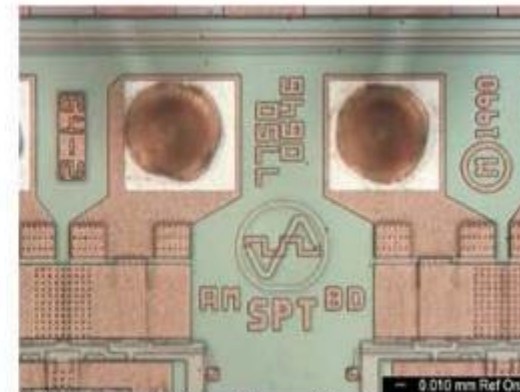

Photo of the Manufacturer Logo

Ref: nisene.com

# Plasma Etching and Laser Decap for Copper Wirebonds

- Radio frequency (RF) energy source is used to ionize gas in a reaction chamber.
- Ionized gas attacks the plastic and the integrated circuit's layer materials.
- Plasma treatment has proven valuable because of its selectivity, gentleness, cleanliness, and safety.
- However, the time involved in opening an entire package with plasma time is too long for routine use and limits its application to the more critical failure analysis studies.
- Plasma etching is typically used as an alternative method only for final removal of residual encapsulant material in devices where residue still persists after chemical decapsulation.
- Laser decap is gaining popularity for packages with copper wirebonds.

# Delidding of Ceramic/Metal Lid Packages

Delidding a cavity-type hermetic package is more straightforward than removing plastic encapsulants; there are no parameters or acid types to select.

To delid a ceramic package with a ceramic lid, the following procedure can be used:

1. Grip the base of the package in a vise or clamp.
2. Carefully score around the glass seal between lid and base with a scalpel or similar sharp instrument.
3. Insert a small flathead screw driver in a corner of the scored area between the lid and base, and gently twist until the cover pops off. For samples not completely scored all around the perimeter, breakage - as opposed to popping off the complete lid - may occur.



# Ceramic Package Scoring Prior to Delidding

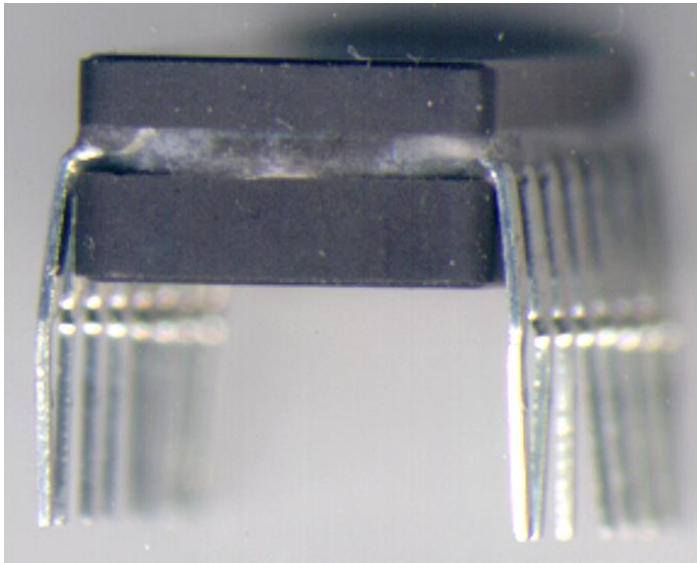

**A**

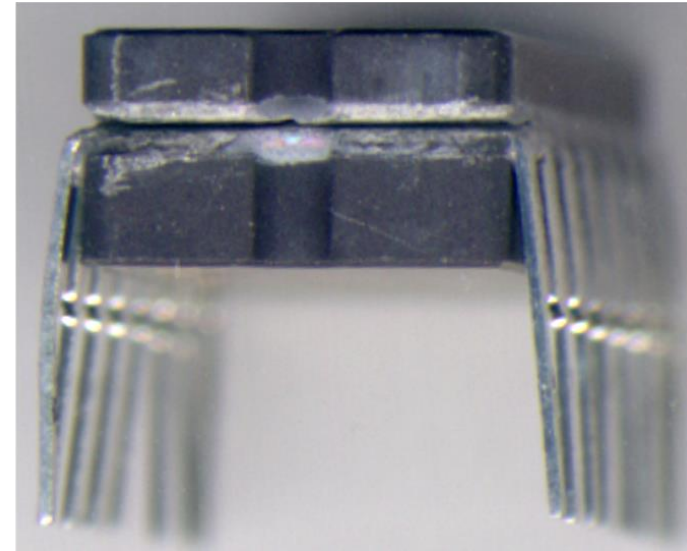

**B**

A ceramic package can be seen before (A) and after scoring the glass seal around the perimeter between the lid and the base (B) in preparation for delidding.

*Ref: engr.uconn.edu*

# Ceramic Package Delidded

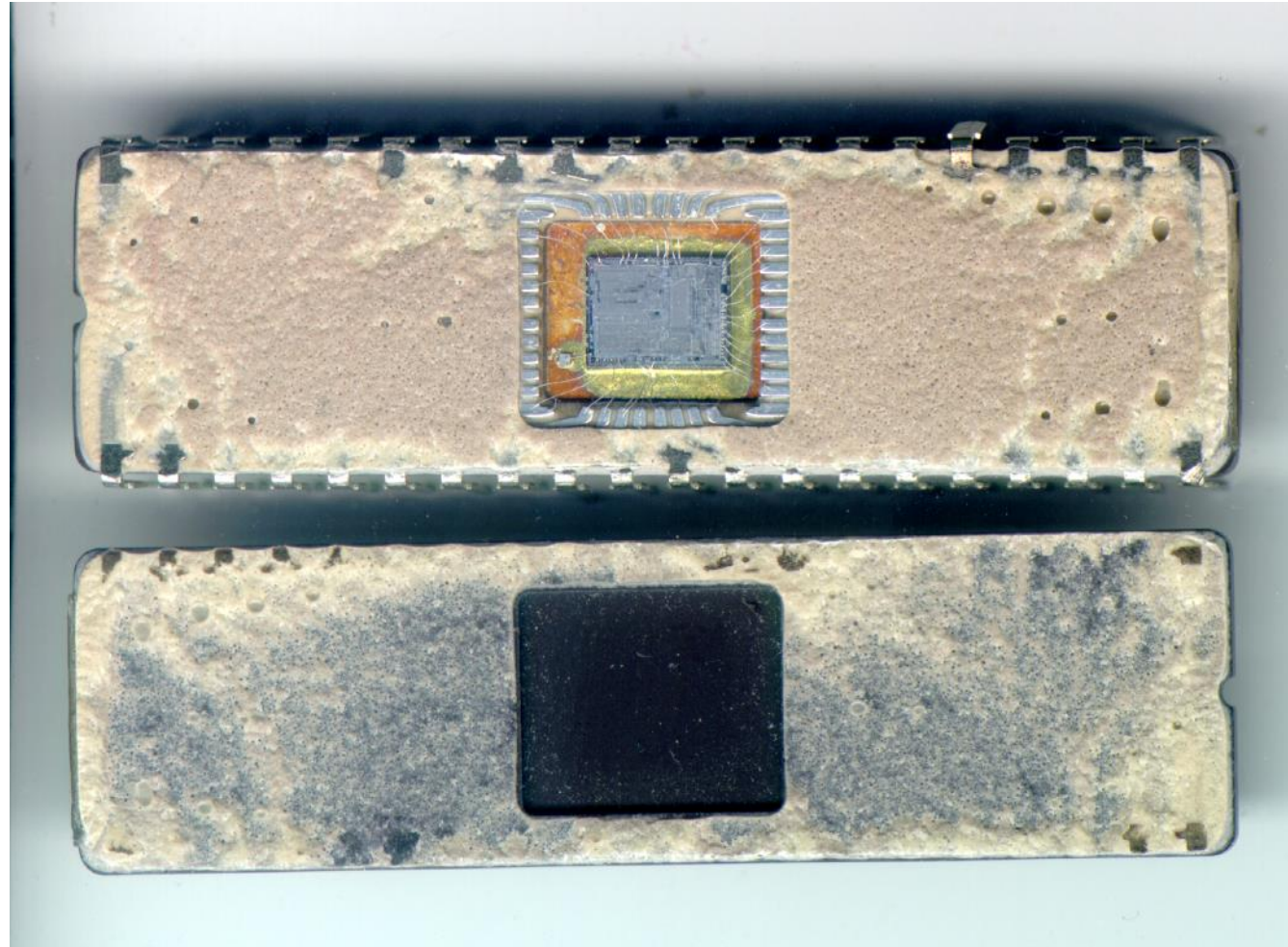

Picture of a delidded hermetic ceramic package. Notice that there are some voids in the top right side of the ceramic base.

*Ref: [enr.uconn.edu](http://enr.uconn.edu)*

# Applications (Chemical Decapsulation)

1. Exposes the die circuitry, and interconnections for inspection using optical and electron microscopy
2. Allows for mechanical wire pull, ball shear and die shear testing
3. Since the decapsulation procedure, if correctly done, is not destructive to the operation of the device, it can permit thermal profiling of the die surface in operation (i.e., identification of hot spots - usually the first areas of failure), assuming that the devices are stored in an inert environment

## Limitations (Chemical Decapsulation)

1. Can only expose die circuitry and interconnections in plastic packages and where the die circuitry is facing the exterior of the package (i.e., not applicable to ceramic, metal cased or flip chip packages)
2. Is difficult to expose the complete die in chip scale packages since the etched cavity is cone shaped, and not much surface distance from die package exterior
3. Over etching can cause the die attach material to be removed and deposited on the die surface, or around bond pads, appearing as dendritic growth
4. Areas in plastic packages that are burnt, charred, or ESD damaged, are highly resistive to the chemical etching
5. Damage to die circuitry can occur in non-passivated devices
6. May remove evidence of bond pad corrosion

# Laser Ablation

- Laser ablation is used to remove the majority of the plastic mold compound.
- Current laser technology is limited to removal of plastic only so as to not damage the die surface.
- Samples are laser ablated to just above the die surface, without making contact at any point with the die surface.
  - Once finished the sample is completed using an automated or manual chemical decap processes.

# Laser Decap - Old vs. Newer Technology

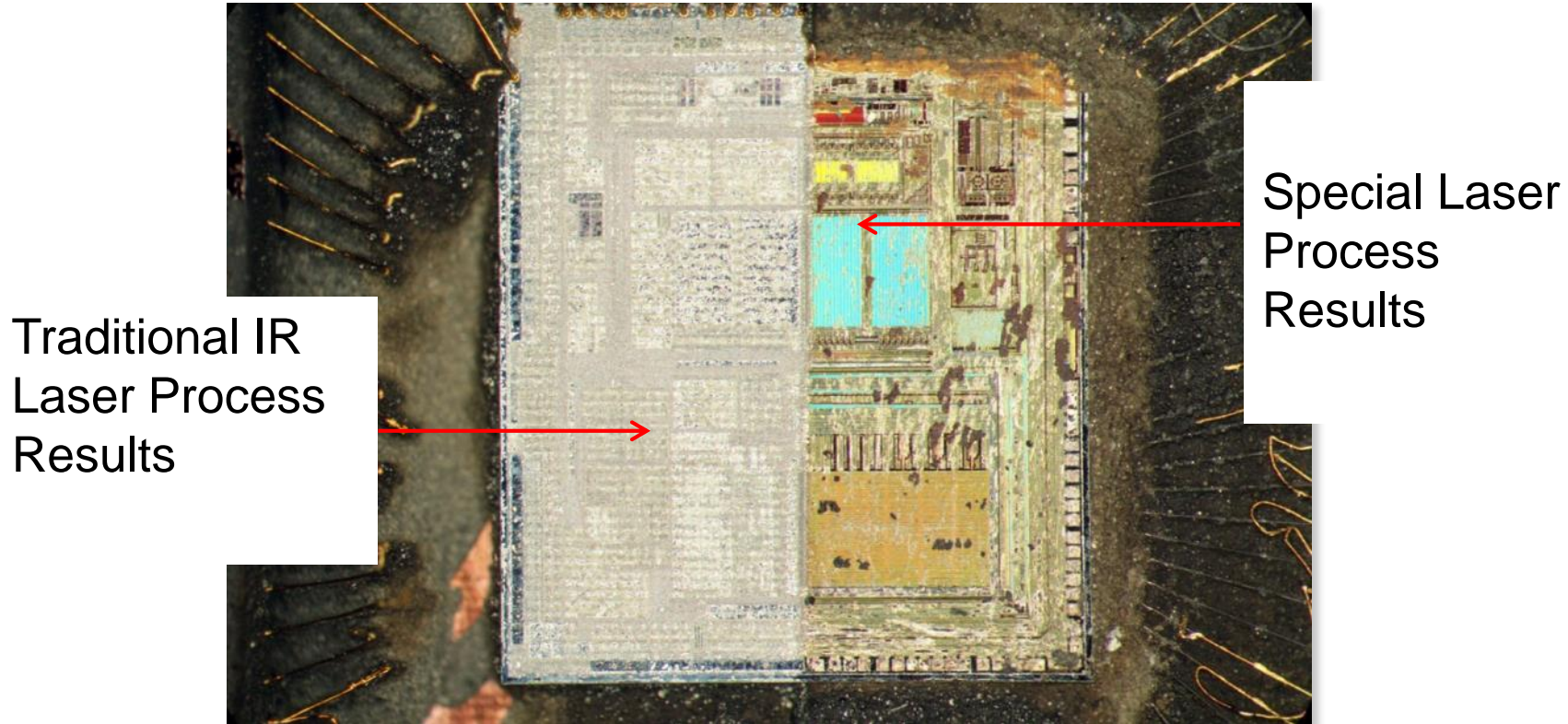

# Dye Penetrant (Dye and Pry)

- Identify failed components (electrical measurement)
- Boards are immersed in stripping agent (Miller-Stephenson MS-111) for 25 min at room temperature to remove the solder mask. IPA can be used for a final rinse. Dry in air.
- Dye is applied to the board (DYKEM steel red layout fluid) with a pipette. Important: Flip the board, so that the dye flows into the cracks
- Place boards in vacuum for 5 minutes so that the dye penetrates into fine cracks that otherwise would be blocked by trapped air pockets. A strong vacuum pressure is not important for this process (Typical 220 mm Hg)
- Place the board on a hot plate for 30min 80° C to dry the dye (as prescribed by DYKEM).

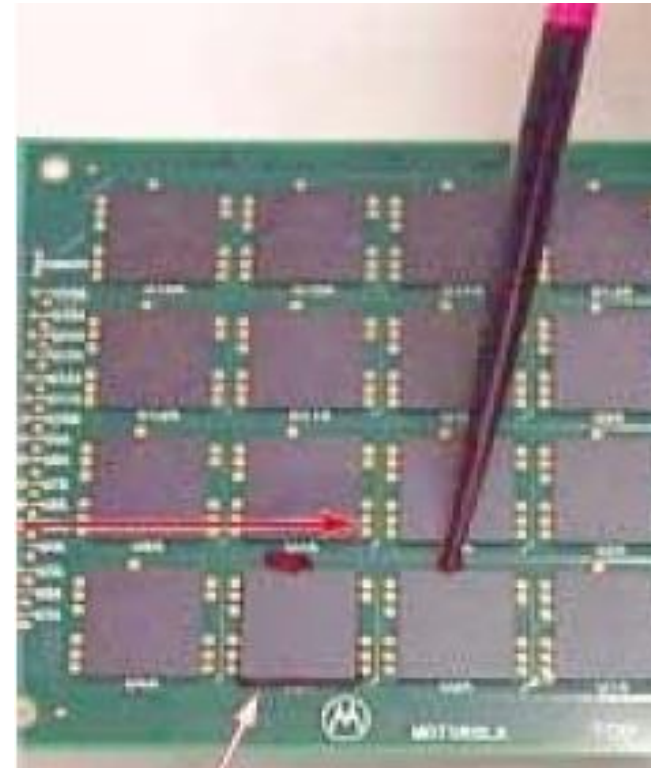

Picture: “Solder joint failure analysis” Dye penetrate technique  
BY TERRY BURNETTE and THOMAS KOSCHMIEDER

# Dye and Pry Steps

- Flex the board with a pair of pliers until the components peel away.
- Remove the components with tweezers and fix with double sided tape on the board, because it is important to see the component side and the substrate side to identify the failure site.

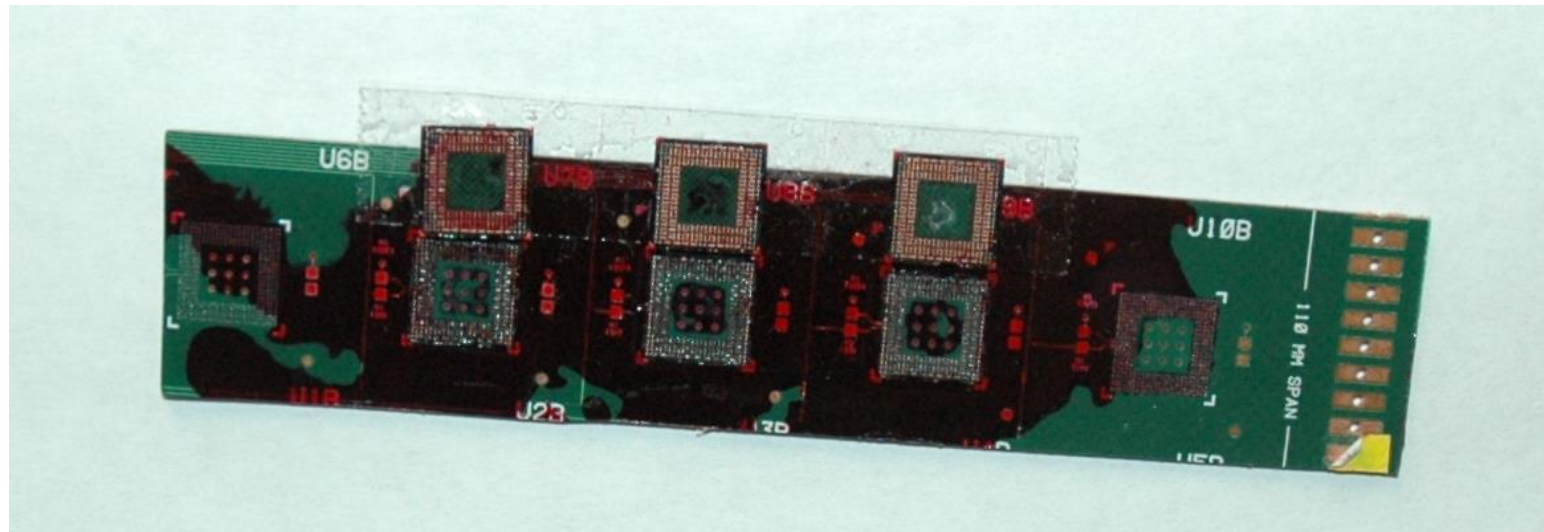

Picture: “Solder joint failure analysis” Dye penetrate technique  
BY TERRY BURNETTE and THOMAS KOSCHMIEDER

# Potential Nonconformities

(For BGAs)

1. Solder Fail  
(component side)
2. Solder Fail  
(substrate side)
3. Pad Lift
4. Trace Fail

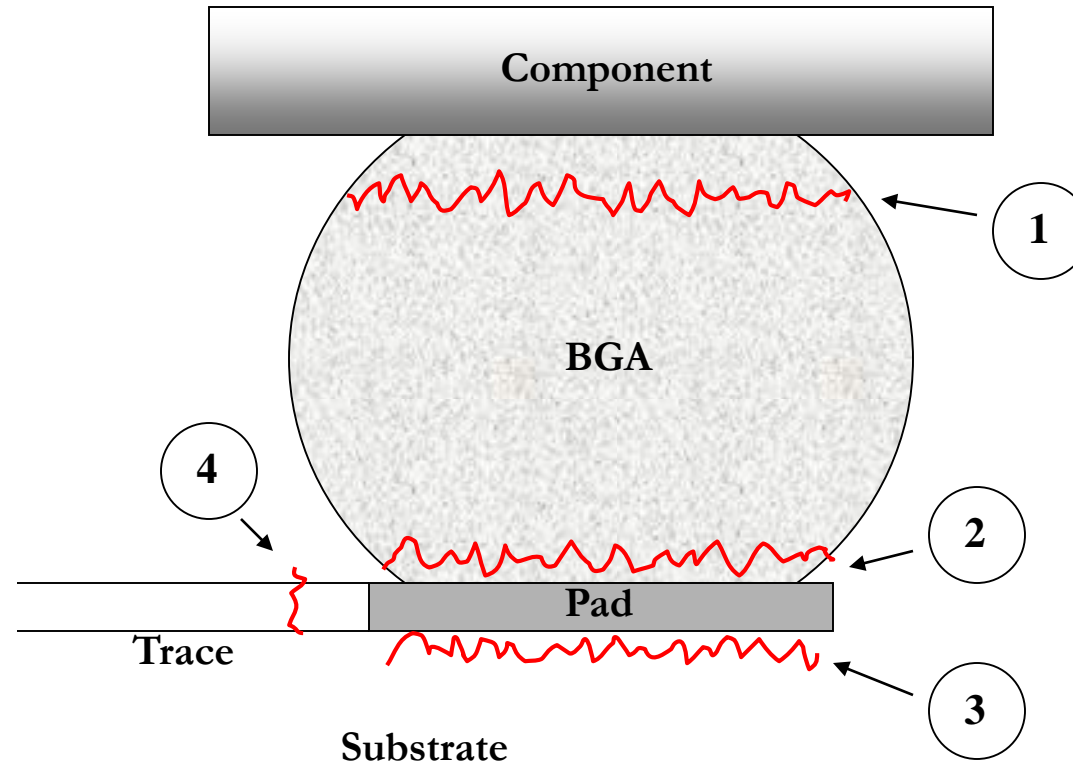



# Dye and Pry: Failure Sites Observed



(a) Failure on board side

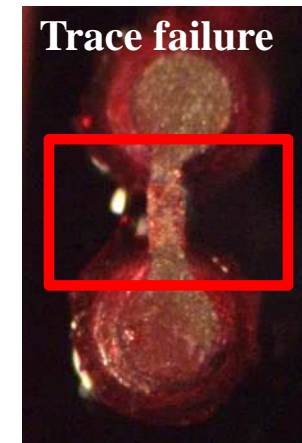

(b) Trace failure



(b) Failure on component side



(d) Pad crater

# Focused Ion Beam Etching

# FIB Introduction

- Focused ion beam (FIB) processing involves directing a focused beam of gallium ions onto a sample.
- FIB etching serves as a supplement to lapping and cleaving methods for failure. The beam of ions bombarding the sample's surface dislodges atoms to produce knife-like cuts.

# FIB Cross-section of Bumps

**SEM image of a die-bump interface after FIB etching. Overview of the interface in**

**(a) shows the bump, die and silver antenna,**

**(b) and (c) show close up of the bump at two sides.**

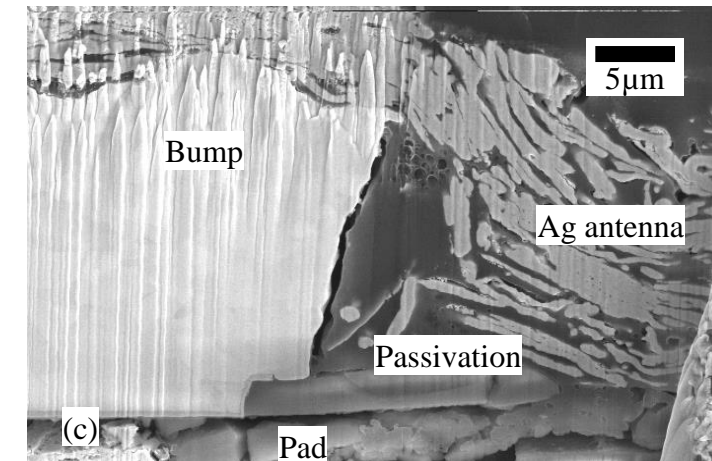
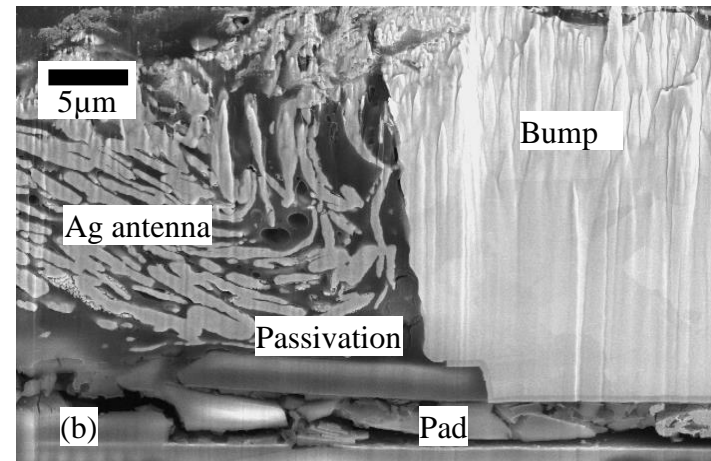
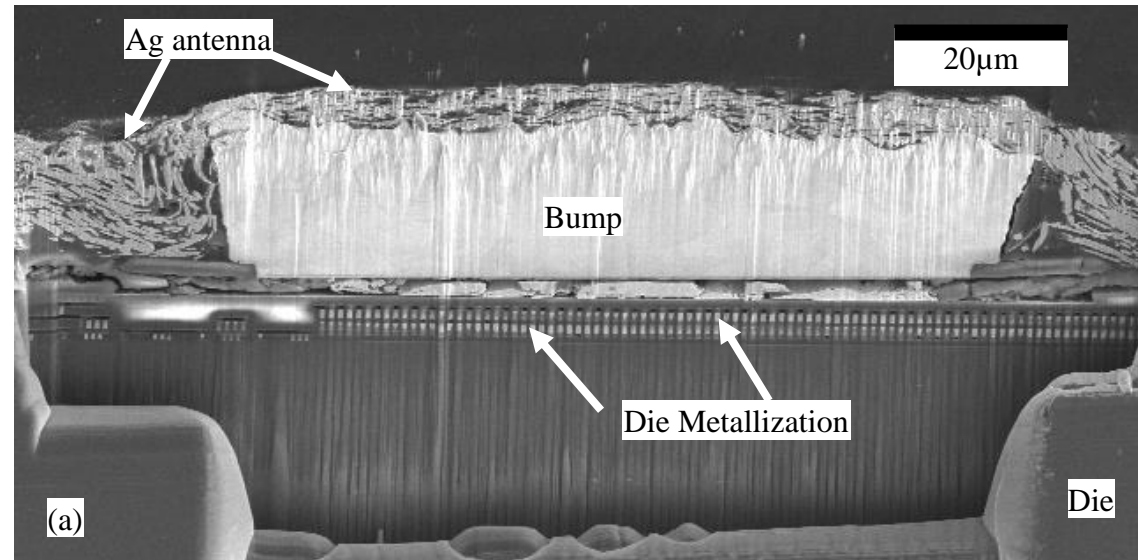

*Ref: Sood, Bhanu, et al. "Failure site isolation on passive RFID tags." Physical and Failure Analysis of Integrated Circuits, 2008. IPFA 2008. 15th International Symposium on the. IEEE, 2008.*

# Focused Ion Beam Limitations

- Equipment is relatively expensive
- Large scale cross-sectional analysis is impractical since the milling process takes such a long time
- Operator needs to be highly trained
- Samples could be damaged or contaminated with gallium
- Different materials are etched at different rates, therefore uniform cross-sectioning using ion milling is not always possible

# Superconducting Quantum Interference Device (SQUID) Microscopy

# Magnetic Imaging Used to Locate Failures

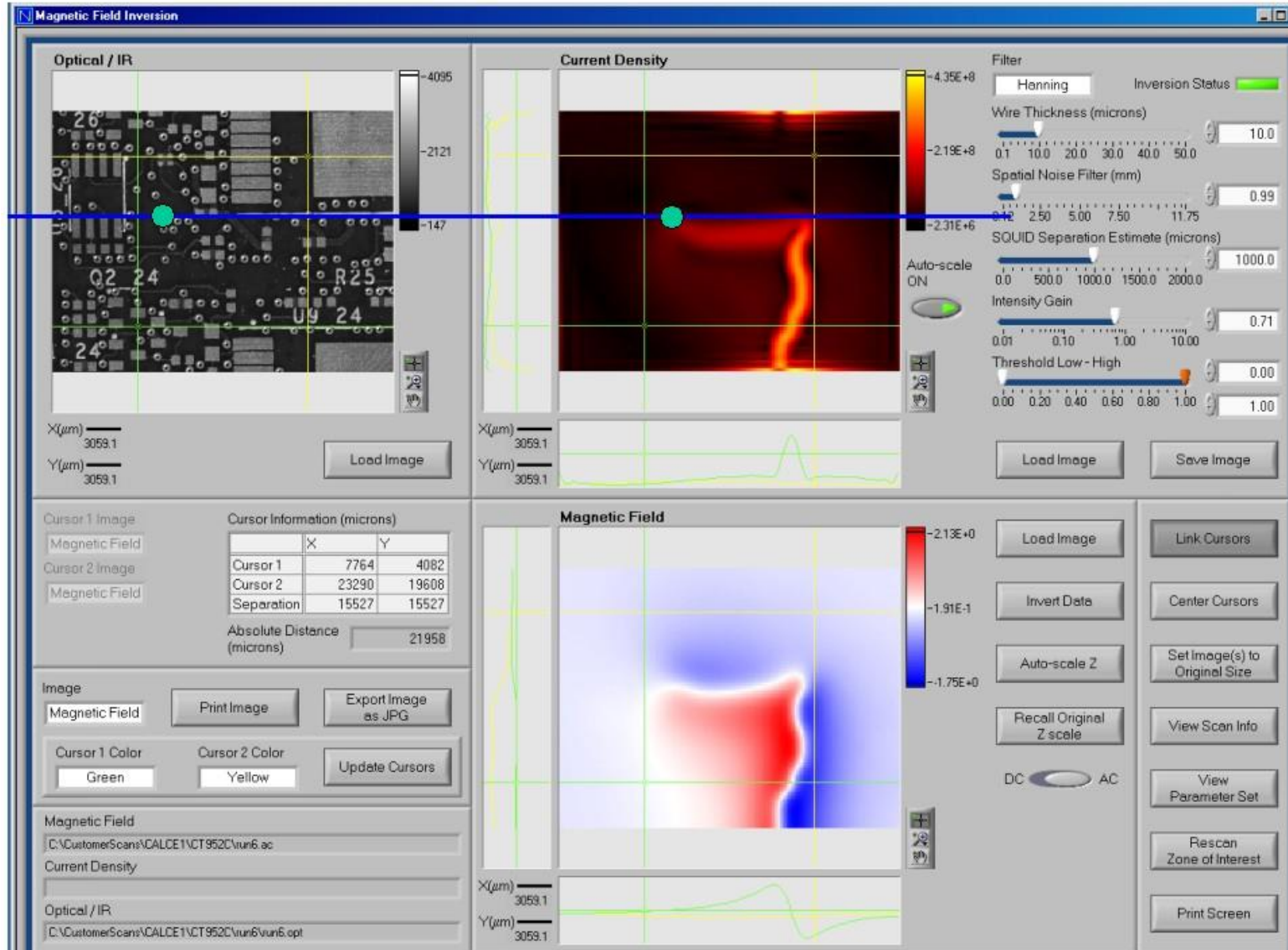

Ref: Sood, Bhanu, and Michael Pecht. "Conductive filament formation in printed circuit boards: effects of reflow conditions and flame retardants." *Journal of Materials Science: Materials in Electronics* 22.10 (2011): 1602-1615.

# **Spectroscopy, including Fourier Transform Infrared Spectroscopy (FTIR)**



# Fourier Transform Infrared Spectroscopy – Spectrum Production

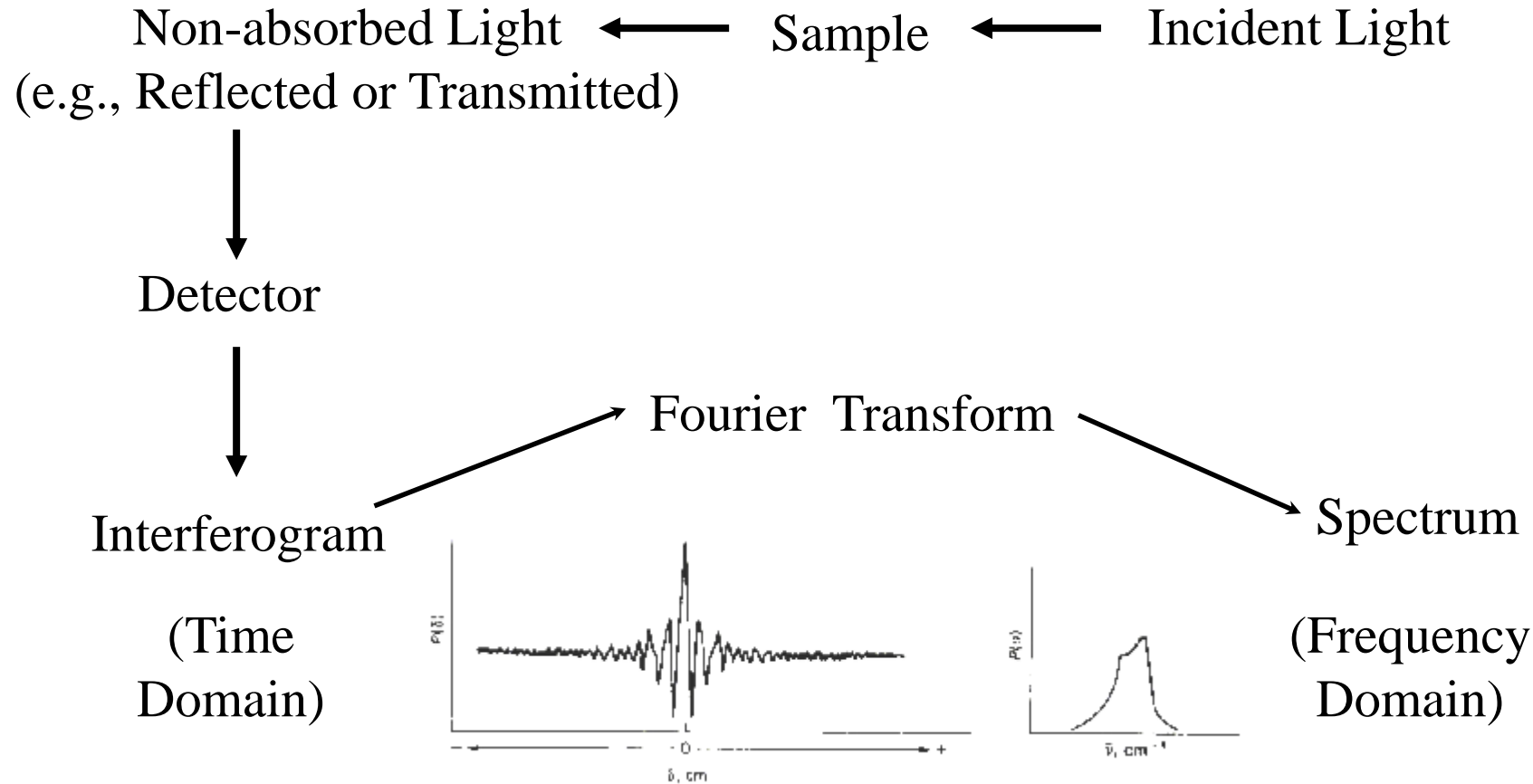

# Properties of an Infrared Spectrum

- An infrared spectrum contains absorption peaks corresponding to the frequencies of vibration of the atoms of the molecules making up the sample.

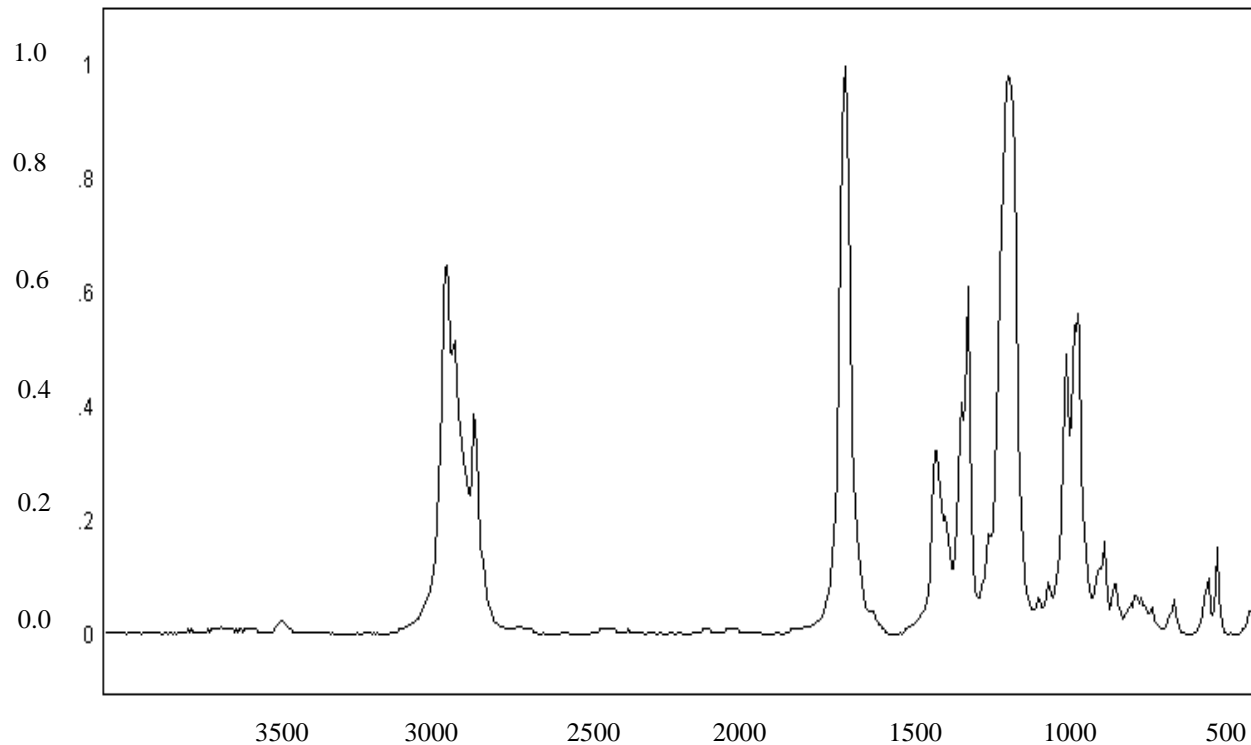

Infrared Spectrum  
of Acetic Acid  
Butyl Ester

# Fourier Transform Infrared Spectroscopy – Spectrum Interpretation

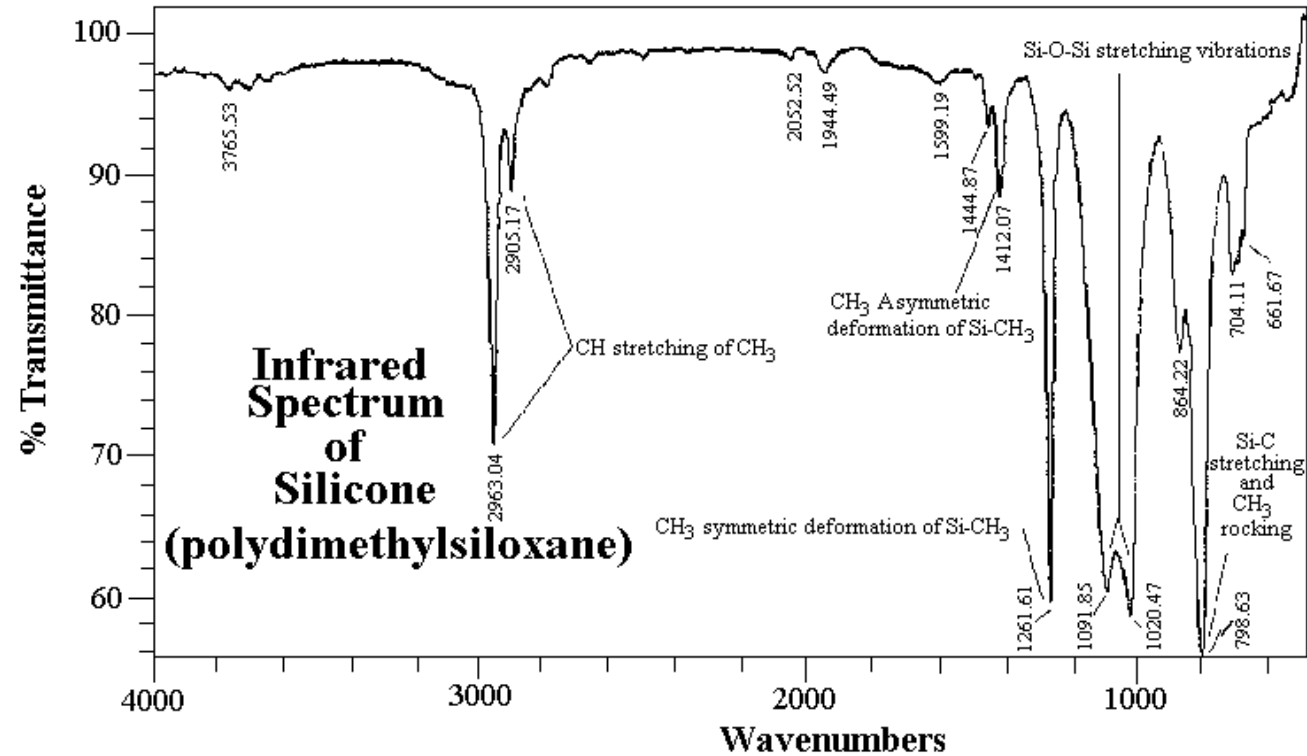

Correlation with charts of characteristic absorption frequencies



Identification of material

Ref: ChemAnalytical LLC: FT-IR Spectra

# Engineering Applications of FTIR

- Materials identification and evaluation
  - Identification of unknown inorganic and organic materials by comparison to standards and by molecular structure determination
  - Determination of the locations of known and unknown materials
  - Determination of material homogeneity
- Failure analysis
  - Identification of contaminants
  - Identification of corrosion products
  - Identification of adhesive composition change
- Quality control screening
  - Comparison of samples to known good and known bad samples
  - Comparison of materials from different lots or vendors
  - Evaluation of cleaning procedure effectiveness
  - Identification of contaminants

# Chromatography

# Ion-exchange Chromatography

- Ion exchange chromatography exploits ionic interactions and competition to realize analyte separation.
- It can be further classified into
  - cation exchange chromatography (CEC): separates positively charged ions; and
  - anion exchange chromatography (AEC): separates negatively charged ions.
- The output of an IC test is a graph of conductivity versus time.
- Calibration is with standards of known composition (elution time) and concentration (peak area).

# Example of IC Results on a Mixture of Anions

- The eluent was 0.01 mol/L NaOH.
- The column used was an Dionex AS11.

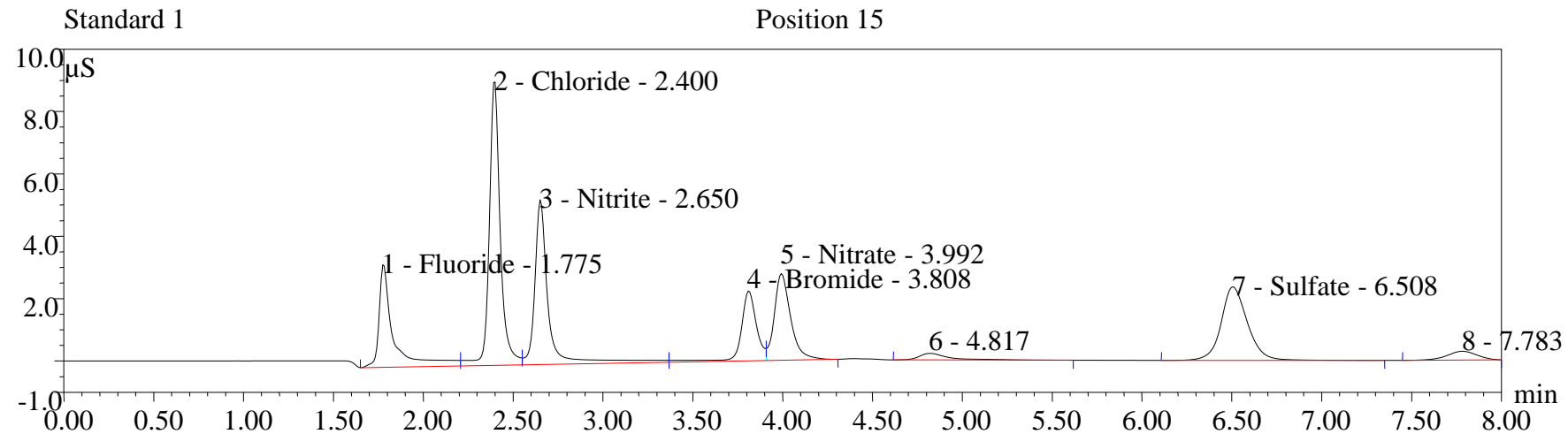

- Based on the retention time, the type of ions can be determined with comparison to standard ions.
- Based on the area under the peaks, the concentration of the ions can be determined.

Ref: Dionex AS11 Carbon Eluent Anion-Exchange Column

# Applications of Ion Chromatography in Electronics Reliability

1. Tests on assembled or bare printed wiring boards (PWBs) to relate cleanliness to electrochemical migration.
2. Determination of amount and type of extractable ions present in encapsulation materials to relate amount and type of ionic content to corrosion failure.
3. Electroplating chemistry analysis to relate breakdown products to plating adhesion failure.

*Ref: IPC-TM-650 Test Method No. 2.3.28*



# Summary

# Restart Criteria

- Failures with severe consequences (e.g., safety) may require processes (e.g., manufacturing, distribution) to be interrupted after discovery of the failure.
- Depending upon the identified root cause, processes interrupted may be re-started if **corrective action** (s) can be implemented that will prevent the recurrence of the failure, or sufficiently minimize its impact.

# Corrective Actions

- Many of the failures having a direct impact on production require **immediate corrective actions** that will minimize downtime.
- Although many immediate actions may correct symptoms,
  - temporary solutions may not be financially justifiable over the “long haul”; and
  - there is a large risk that a temporary solution may not solve the problem.

# Verification

Verification of the corrective action includes:

- verifying the approval and implementation of the corrective action;
- verifying a reduction in the incidence of failures;
- verifying the absence of new failures associated with the failure sites, modes, and mechanisms identified during the failure analysis.

# Root Cause Analysis Report

The report should include the following information:

1. Incident summary
2. History and conditions at the time of failure
3. Incident description
4. Cause evaluated and rationale
5. Immediate corrective actions
6. Causes and long-term corrective actions
7. Lesson learned
8. References and attachments
9. Investigating team description
10. Review and approval team description
11. Distribution list

# Failures of a Failure Analysis Program

- Shutting down the malfunctioning equipment
- Refusing to recognize that a failure can or does exist
- Assuming an apparent cause to be the root cause
- Determining the failure cause by assumption
- Collecting insufficient information and ending an analysis before it is complete
- Discarding failed parts
- No documentation

# Further Suggested Reading

- Journal of Failure Analysis and Prevention, ASM International.
- Electronic Device Failure Analysis (EDFA) Journal, ASM International.
- Engineering Failure Analysis, Elsevier.
- Electronic Failure Analysis Handbook, Perry L. Martin, McGraw-Hill Professional.
- Microelectronics Failure Analysis Desk Reference (Book + CD set) [Hardcover], EDFAS Desk Reference Committee.

# Questions?





# Acknowledgements

- \*NASA GSFC SMA Mission Assurance Directorate
- \*NASA GSFC Risk and Reliability Branch (Code 371)
- \*NASA Workmanship Program

**Thank you!**

**Bhanu Sood**

**Safety and Mission Assurance (SMA) Directorate**

**NASA Goddard Space Flight Center**

**Phone: (301) 286-5584**

**bhanu.sood@nasa.gov**