

Capture Latch Assembly for the NASA Docking System

Brandon N. Dick^{*}, Nathan Mauch^{*} and Timothy Rupp^{**}

Abstract

This paper will present a summary of the Design, Development, and Qualification of the Capture Latch Assembly (CLA) for the NASA Docking System (NDS) Block 1 (NDSB1). The CLA is an integral part of the Soft Capture System (SCS) of the NDSB1, serving the purpose of connecting the mating SCS Rings of two docking vehicles. The paper will present an overview of the function of the CLA and its basic concept of operations, including a summary of the major components of the CLA. The development, qualification, and production of the CLA will then be described. Particular focus will be provided on two major issues that occurred during production and qualification of the CLA. The first issue was failures of the CLA Motor (CLM) during acceptance testing (AT). The failures of the CLM were ultimately determined to be due to design defects and manufacturing errors in the motor commutation sensor assembly. The second issue was failure of the secondary release mechanism, or Contingency Capture Latch Release (CCLR) mechanism during development and qualification testing. The CCLR failures were found to be a result of excess free play in the release mechanism, resulting in wear leading to galling inside the release mechanism. An overview of each failure will be provided, along with a summary of the failure investigation and recovery process. Finally, Lessons Learned from each of the major issues and the overall development of the Capture Latch will be presented.

Introduction

The Capture Latch is an indeterminate mechanism in the NDSB1 tasked with providing the initial connection (soft capture) between space vehicles during a docking procedure. The Capture Latch maintains the connection between space vehicles during initial contact, vehicle alignment, and vehicle hard capture. Once hard capture is completed the capture latches are released and the NDS SCS is stowed. Each NDS has three latches, one on each petal of the NDS as shown in Figure 1.

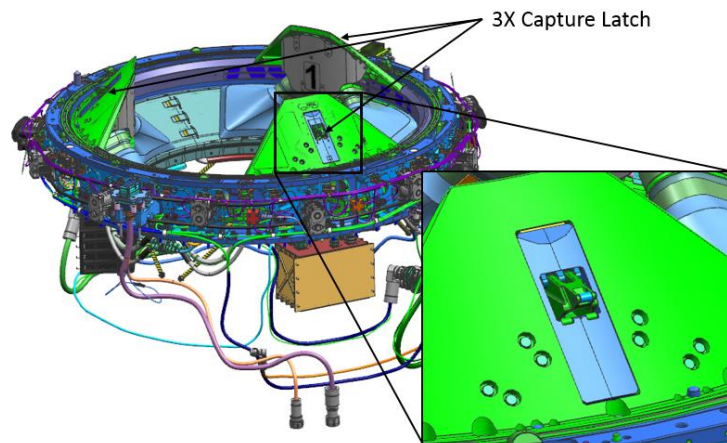

Figure 1. NDS with 3 Capture Latches

^{*} The Boeing Company, Huntsville, Alabama

^{**} NASA Johnson Space Center, Houston, Texas

The CLA is a derivative design of the latch on the docking system used in the Apollo–Soyuz Test Project (ASTP) [1]. The ASTP latch design was further refined for follow-on docking systems including the APAS-95 docking system used in the space shuttle [2]. There were several critical upgrades in this design revision that were previously absent. They include the ability to release under significantly larger loads, meeting requirements set forth in NASA-STD-5017 (design for minimum risk), and an automated secondary release.

Design Requirements

The primary CLA requirements were derived from system performance characteristics and needs. The primary requirement was to be able to release under a specified tensile load quickly enough to ensure two vehicles could detach during a failed docking attempt without collision between spacecraft or damage to the NDS.

The secondary release requirements were derived for conditions under which the capture latch experienced a failure in the primary drive train and had to be released very quickly. The pre-capture force of the mechanism had to be limited to reduce the amount of forward vehicle velocity needed to push the latches out of the way and complete a capture. The latch is designed for a relatively short mission life of 214 days on-orbit with up to 4 dockings per mission.

Design Overview

Figure 2 shows the main components for the capture latch mechanism. They are:

1. **Motor:** Provides the nominal actuation for the mechanism. The motor is a dual wound brushless motor with redundant Hall-Effect Device (HED) position sensors. Each string of the motor is driven by a separate controller.
2. **Latch Pawl:** Latching feature that reacts load from Passive Striker to attain capture between mating docking systems. Can be positioned to latch (Ready to Capture) or release (Ready to Release) using the motor.
3. **Transmission/Linkage System (internal, not shown):** Transmits torque from the motor to the Latch Pawl and retains the pawl in desired position.
4. **Secondary Release Mechanism:** Provides for secondary release in the event of a nominal drive system failure. The mechanism contains a Non-Explosive Actuator (NEA) that is activated with a simple on/off power supply. The mechanism also contains a compressed spring which provides the force necessary to extend the Secondary Release Mechanism and drive the latch into the released mode.
5. **Passive latch striker plate:** This is a simplified representation of the stationary latch interface hardware on the passive docking system.

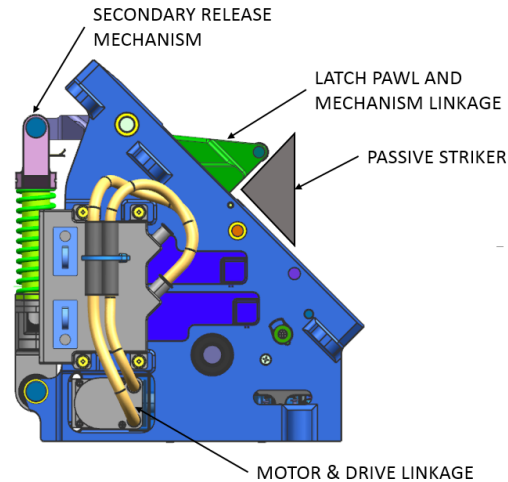

Figure 2. Latch Nomenclature

The capture latch mechanism has three main configurations or modes, as shown in Figure 3 and Figure 4: Ready to Capture (RTC), Ready to Release (RTR), and secondary release. The RTC position (Figure 3.1) is the nominal mode that allows for the latch to capture and hold the passive striker on the opposing docking system. The ready for release (Figure 3.4) and secondary release (Figure 4) modes allow for the release of the striker plate. The RTR mode is the nominal release position achieved via the motor drive system. This is the primary release mode utilized while the latch is operating nominally. The secondary release mechanism allows for the release of the passive striker plate in the event the latch drive system is rendered inoperable (whether due to motor failure, jamming, binding, seizing, etc.) The secondary release mechanism is operated via a Non-Explosive Actuator (NEA) that releases a spring operated push rod. Once the secondary release mechanism is fired the system is in an unrecoverable released state and the latch can no longer perform docking.

A full nominal capture and release operation is shown in Figure 3. The operational steps are as follows:

- Step 1: Latch is set to the ready to capture mode.
- Step 2: During docking the incoming passive latch depresses the latch pawl.
- Step 3: The latch pawl passively snaps over the striker plate.
- Step 4: To release the motor and drivetrain reposition internal latch linkages to a Ready To Release configuration.
- Step 5: The latch pawl is then pushed and rotated out of the way by the passive latch striker plate.
- Step 6: The motor and drivetrain reconfigure the internal latch linkages into the Ready To Capture mode. The latch is ready for another nominal docking operation.

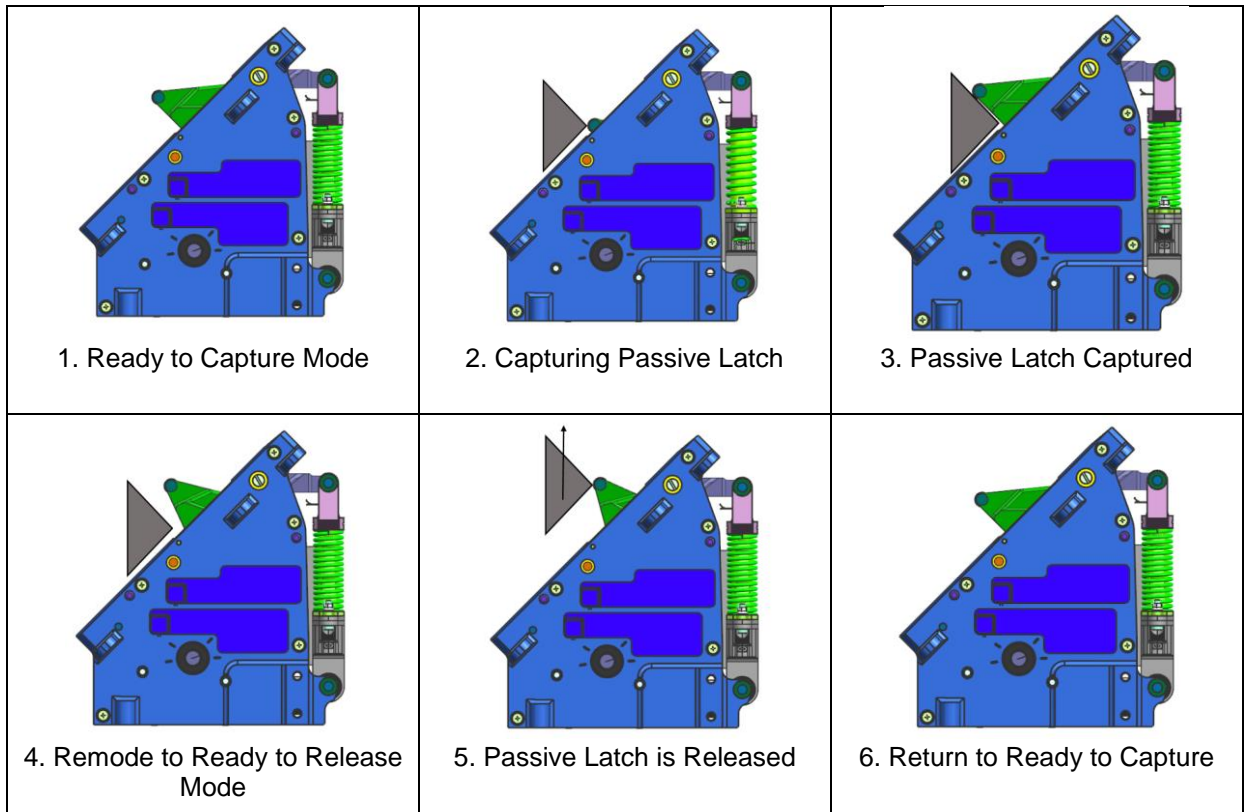

Figure 3. Nominal Capture and Release Sequence

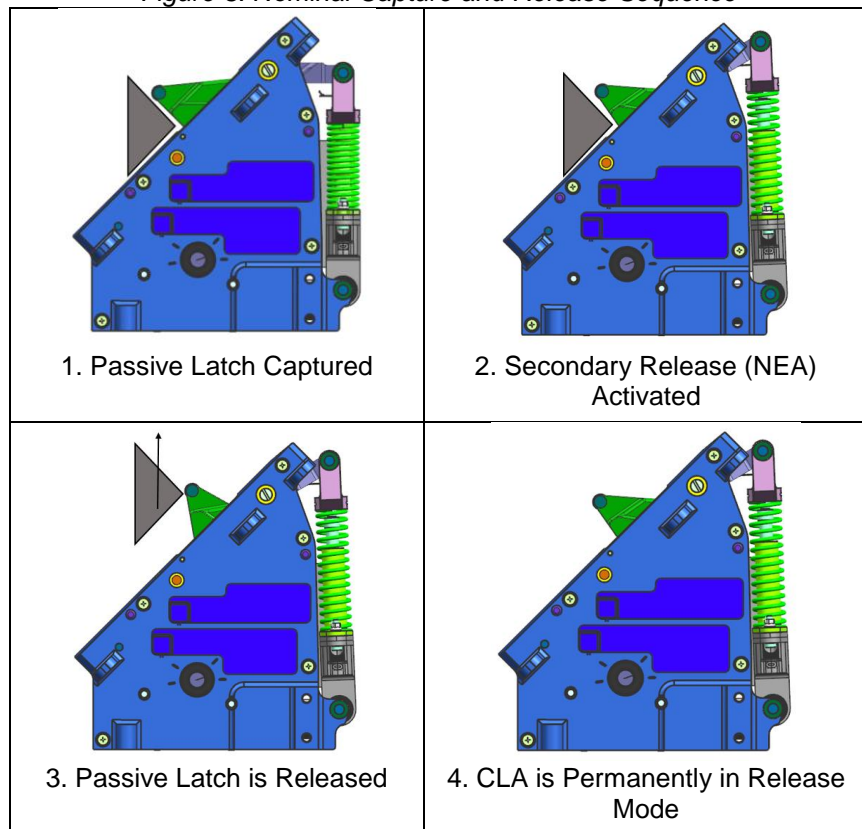

Figure 4. Secondary Release Sequence

A secondary release operation is shown in Figure 4. The operational steps are as follows:

Step 1: Latch is in the ready to capture mode and has captured the passive latch.

Step 2: After a failure of the primary drive system the secondary release mechanism is activated and the NEA releases energy stored in the compression spring, causing the secondary release mechanism to extend.

Step 3: The latch pawl is then pushed and rotated out of the way by the passive latch striker plate.

Step 4: The capture latch is now permanently in the secondary release mode.

Summary of Development/Qualification/Acceptance Testing

Development Testing

The purpose of the Capture Latch Development Test was to reduce technical risk associated with the assembly and test of the flight design configuration by conducting testing early in the project. The development unit was built to the same design configuration as the flight Capture Latch. Some variations from the flight design were permitted to facilitate a quick test. First, the NEA in the Secondary Release Mechanism was a development article and the spherical bearing at the base of the NEA was not swaged in place. Second, the Capture Latch Motor and Controller were also development articles. Lastly, the cover for the controller was a 3D-printed metal casing, instead of the flight machined part.

The development test consists of the following tests: 1. Run-In, 2. Functional, 3. Random Vibration (qualification levels/durations), 4. Thermal Vacuum (TVAC), 5. Primary Release, 6. Secondary (NEA) Release, and 7. Static (Ultimate) Load. Run-In testing consists of five functional cycles, where the Capture Latch is cycled between RTC and RTR modes. Functional testing starts with the Capture Latch in RTC mode. A test fixture is used to simulate docking and verify that the latch engages a passive latch striker. The latch is then commanded to RTR mode and the test fixture is used to simulate undocking. Functional testing was completed using both the A and B string motor/controller. During vibration testing, the capture latch was mounted on a fixture on a vibration table and subjected to the Qualification vibration spectrum in each of the three axes (X, Y, and Z). Between each axis and after the final axis, the Latch was functionally tested. During TVAC testing, the unit is placed in a thermal vacuum chamber and functionally tested at both the hot and cold vacuum conditions. The Primary Release test demonstrates that the capture latch can release while loaded up to the maximum expected load for undocking at both ambient and vacuum conditions.

The Secondary (NEA) release test demonstrates that the secondary release mechanism can release the latch when subjected to the maximum expected load during a contingency release. This test was conducted only at ambient conditions. Finally, the Static (Ultimate) load test demonstrates that the Capture Latch remains contained after being subjected to the ultimate design load.

All development tests were completed successfully except the Secondary Release test, which failed. This test will be discussed later.

Qualification Testing

Qualification testing was the same as development testing, with the following exceptions. Thermal Cycle testing was included, with 24 cycles to the same temperature extremes as the development test. Three thermal vacuum cycles were conducted. Finally, a Life Cycle test was performed.

All tests were completed successfully, with two exceptions. (1) During the Thermal Vacuum test, one channel of the motor failed as described in the next section of this paper. However, since one string of the motor was still operational, the test was allowed to continue with the remaining string. (2) The Secondary Release Mechanism failed to release the latch during the Secondary Release Test. This test failure is also discussed in subsequent sections of this paper.

Acceptance Testing

The Acceptance Test (AT) consists of the following tests 1. Run-In, 2. Functional, 3. Random Vibration (qualification levels/durations), 4. Thermal Vacuum (TVAC), and 5. Primary Release. In general, the levels and durations of exposure are lower during AT, as compared to qualification testing. NEA functionality cannot be checked since the NEA is a single use item.

The AT was successful in screening a number of minor defects in some of the capture latches. Minor defects detected included limit switch rigging issues, worm gear alignment problems, and motor-to-controller splicing deficiencies. The test also uncovered a major defect in the motor assemblies, which will be discussed later.

Motor Failures During Acceptance Testing

Description of Failures

Failures occurred in four separate motors during Capture Latch Assembly AT at Boeing and at the supplier of the motor/controller. A timeline of events is shown in Table 1. The initial failure (Failure 1) occurred during AT of the Capture Latch motor at the supplier. During the ninth hot cycle of the Thermal Cycle test, the motor ceased operating on the A string. The second failure (Failure 2) occurred during Thermal Cycle testing of the Capture Latch Assembly at Boeing. During the eight hot cycle of the thermal cycle test, the motor failed to operate on the B string. The third and fourth failures (Failure 3 and Failure 4) occurred during Hot Thermal Vacuum testing of the Capture Latch Assembly at Boeing. During this test, high current spikes were observed and the units operated intermittently on both the A and B strings.

Table 1. Motor Failure Timeline of Events

August 2015	Failure 1 – Motor AT Thermal Cycling
November 2015	Initial investigation of Failure 1 completed
December 2015	Start of Capture Latch AT
February 2016	Failure 2 – Capture Latch AT Thermal Cycling
March 2016	Failure 3 & 4 – Capture Latch AT Thermal Vacuum
July 2016	Failure Investigation and Redesign complete
October 2016	Restart Capture Latch AT

Failure Investigation Summary

After the occurrence of Failure 1, the supplier performed a failure analysis. The supplier confirmed the B string of the motor functioned properly even though the A string had failed, indicating the failure was not related to mechanical binding inside the motor assembly. Further, they were able to validate the failure was isolated to the motor, not the test equipment or the motor controller. Fault isolation testing showed that on the A string of the motor, one of three HEDs on each string was non-operational. Pre-teardown imaging of the motor was determined to be possible but impractical due to the difficulty of imaging through the metal casing of the motor. Additionally, the motor could not be disassembled without damage due to the permanent manner in which the casing was assembled. Therefore, it was determined that the only practical troubleshooting step remaining was a destructive teardown of the motor, to be followed by X-Ray imaging and physical inspection of the affected HED subassembly. These steps were performed, but no clear cause of the failure was identified.

Out-of-place solder was observed adjacent to the failed HED, however, it could not be determined whether this solder was the cause of the failure or if it had flowed there during the teardown, which involved heating up the motor to loosen epoxy on the casing. A review of the soldering processes for the HED was performed and a defect in the process was identified. A full fault tree was developed for the issue, but no additional likely causes were identified at the time. The soldering process issue was determined to be the most likely cause of the failure.

Failure 2 occurred approximately four months after Failure 1. After the failure occurred, an investigation along with troubleshooting testing began. The test setup was exonerated as the cause of the failure following a thorough inspection and checkout of the equipment. A full timeline outlining the history of the failed unit was developed, starting with assembly and test of the motor/controller at the supplier and continuing up through the failure. The timeline showed that unit had performed nominally through all assembly and test activities, until TVAC testing. Erratic behavior in the CLA began to emerge during the TVAC test. During operation of the Capture Latch Motor, there are three parameters monitored, current and voltage applied to the active string and voltage on the inactive string. Voltage on the active string is controlled by the test equipment and remains relatively constant. Current provides an indication of motor performance, although the current measurement is taken between the test equipment and motor controller and not between the motor and motor controller.

Because the controller affects the current demand through its own usage and current limiting, it does not provide direct insight into the motor performance. But large variations in current are indicative of motor behavior. The third parameter measured during Capture Latch Motor operation is voltage on the inactive string, which provides an indication of the speed of the motor. Since the motor has dual windings, the inactive string generates current during operation. Like the current reading, this is also filtered through the controller, so the reading at the test equipment is not a direct measurement. However, large variations are indicative of changes in motor speed. In Failure 2, the motor current exhibited significant current dropouts on the B string during the hot test.

These dropouts did not cause the motor to slow down significantly as evidenced by the fact that the inactive (A-String) voltage remained relatively constant, and the transition time was nominal. Because the unit transitioned normally, the spikes in current were not flagged by the Test team for evaluation.

After this initial indication of an issue, the latch proceeded through the remainder of the TVAC test as well as the first 5 cycles of the Thermal Cycle test without issue. During the sixth hot thermal cycle, the latch again exhibited current spikes. This occurrence was much more severe, with more spikes resulting in a slower transition time for both the A and B strings. Although this was abnormal performance, it was within the threshold established for compliance and was not flagged by the Test team.

During the subsequent cold operation, the unit failed to meet the transition time requirement. Review of the data showed no current spikes, but the inactive string voltage was abnormally low, indicating a slow motor speed. At this point troubleshooting of the failure began, which included inspections for debris (none identified) and operation of the motor at temperature with data recorded at a higher sampling rate. The motor operated inconsistently, where some operations were nominal whereas other operations had current spikes. The motor/controller supplier reviewed this data and concluded that this current signature was consistent with either a failed HED, a failed HED circuit in the controller, or a break in the wiring for the HEDs between the two.

At this time it was determined that the motor and controller should be returned to the supplier for further investigation. Prior to shipment, the wires between the motor and controller were inspected to confirm no wires were damaged or cut.

Upon receipt of the motor/controller, the supplier replicated the failure observed during the acceptance test. The motor and controller were separated and tested individually to isolate the failure. This individual testing showed the motor as the source of the failure and that a teardown and inspection of the motor would be required to determine the cause of the failure. However, based on the experience of Failure 1, where the teardown process was too destructive, additional NDI (Non Destructive Inspections) were performed prior to teardown. Using Time Domain Reflectometry (TDR) inspection techniques, a break in the wiring in the vicinity of the HED was identified, either in the HED itself, the solder joint at the circuit board, or immediately adjacent to the solder joint. Initial X-Ray imaging through the casing of the motor failed to provide meaningful images. Therefore a careful disassembly of the motor was performed, with additional care taken

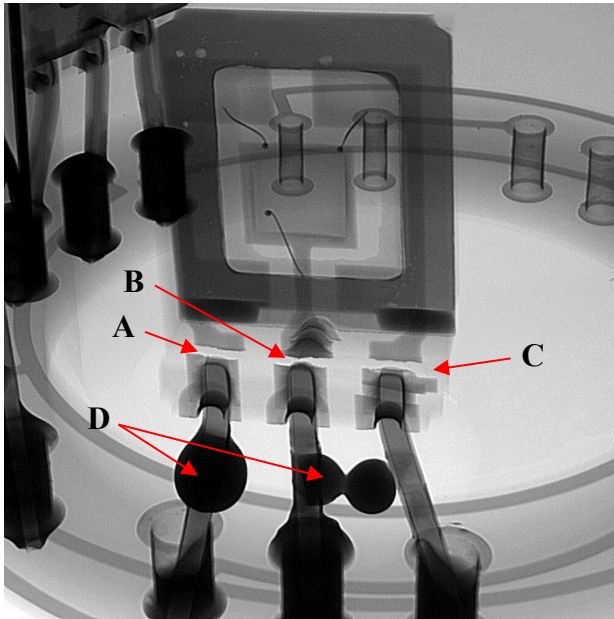

Figure 5. HED X-Ray Showing Cracked Lead

to avoid heat related damage that occurred during the disassembly of the motor in Failure 1. High resolution imaging and X-Ray imaging was performed on the HEDs, which ultimately revealed the cause of the failure, cracks in the HED and HED lead wires, as shown in Figure 5 (items A, B, and C) and Figure 6 (item A). The imaging also revealed the presence of large voids in the potting compound used to fix the HEDs in place, as shown in Figure 5 (item D) and Figure 6 (item B).

Root Cause

Once the fault had been isolated to the HED leads, a root cause analysis was performed to determine why the cracks in the leads had occurred with two contributing factors identified. First, it was noted that the HED leads were splayed apart during assembly to align with holes in the printed circuit board, as shown in Figure 5. The reason the leads were splayed apart during assembly was that an existing circuit board, designed for HED's with different lead spacing, was used for the Capture Latch motor to

minimize development costs. While NASA processes do allow for forming of leads in situations like this, a minimum distance must be maintained between bends in the leads and any joints. In this application, the minimum distance was not maintained for the solder joint at the body of the HED, resulting in stress concentrations at the solder joint and ultimately crack formation over time.

The second contributing factor and root cause was thermal induced stresses in the HED and its lead wires caused by voids in the potting material. These voids allowed for large thermal gradients between the exposed and unexposed portions of the HED, leading to large component stresses and crack formation. The voids were a byproduct of the process for applying and curing the potting material which did not sufficiently eliminate entrained air bubbles prior to curing. The voids were caused by weaknesses in the degas process, and by difficulties containing the potting material prior to curing in the small surrounding volume. Additionally, it was found that differences in the Coefficient of Thermal Expansion (CTE) of the potting material and adjacent materials contributed to the high stresses in the HED.

Corrective Action

There were a number of corrective actions performed to resolve this issue. First, the primary root cause was addressed by changing the potting material to a new type that was easier to remove entrained air bubbles and with a CTE that was more compatible with the encapsulated materials. The degas process was improved to ensure bubbles were removed from the potting material and the HED was also encased in RTV silicone to cushion it during thermal expansion. Additional measures were also taken to ensure that if a motor with large voids was produced in spite of the improved processes, it would be flagged and removed from use. To that end, inspections of the potting material were implemented so motors with large voids are rejected. Additionally, the motor testing process was revised (both at the supplier and at Boeing) to include oscilloscope based current monitoring to confirm all HED operate nominally. Furthermore, a

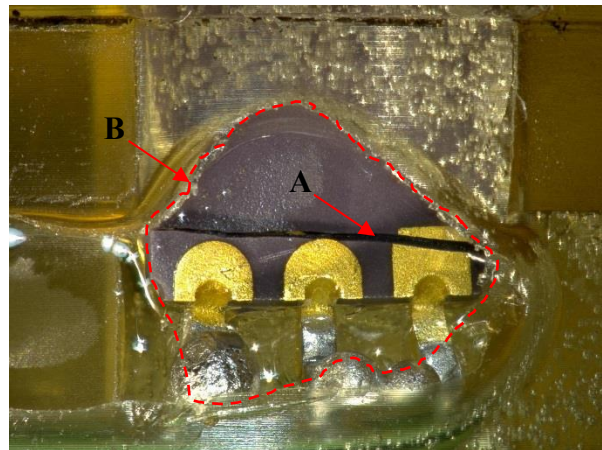

Figure 6. HED Image Showing Body Crack

secondary corrective action changed the circuit board design to allow for installation of the HEDs without lead forming.

Results

The redesigned motor was subjected to qualification testing and no issues with the HEDs were identified. Additionally, all twelve flight motors successfully completed all Acceptance Testing (AT), at the component, subsystem, and system levels, without any issues.

Secondary Release Mechanism Failures During Qualification Testing

Description of Development Test Failure

The initial failure of the CCLR occurred during testing of the development Capture Latch. Prior to the failure the CLA had been subject to a suite of tests for the Capture Latch, including functional tests, random vibration, thermal cycling, and thermal vacuum. The secondary release test was the next to last test, to be followed only by an ultimate load test.

The CCLR failure was the first significant issue that occurred during the CLA development test although one off nominal condition was noted earlier in test which later proved to be a missed indication of the eventual failure. During the random vibration test the spherical bearing located on the NEA pushed its way out of the NEA housing. After investigating, it was determined that the issue was caused by the development configuration of the NEA. The spherical bearing in the development NEA was only press fit and not swaged in place. Swaging was skipped to allow quicker delivery of the NEAs, but skipping this critical process allowed the bearing slide out of the housing during the test. Even without the swage, the press fit bearing should not have moved without being subjected to extremely high side loads, which was overlooked in the test article assessment. As a result, the bearing was pressed back into place and development testing resumed.

The secondary release qualification test is conducted at the worst case cold temperature in a vacuum and performed with a large load applied to the Latch pawl, which simulate the worst case condition for operation of the mechanism on-orbit. For the development test, however, it was determined that the test would be conducted at ambient conditions. During the test, the mechanism is not directly observable and instead it is monitored using sensors. A position sensor mounted on the load attached to the Capture Latch pawl provides confirmation that the Latch has released and current monitoring on the NEA activation circuit confirms the proper application of current/voltage to the NEA.

After the NEA was activated, the mechanism failed to release which would have been evident by the sound of the dropping counterweight and data from the position sensor.

Development Test Failure Investigation Summary

The test setup was inspected to be sure the correct electrical signal was passed to the NEA and shown to be correct. A continuity measurement on the NEA electrical leads indicated an open circuit, consistent with an activated NEA. The hardware was inspected but no signs of debris or other jamming was evident indicating a potential jam inside the secondary release mechanism. The hardware would need to be unloaded and removed from the fixture prior to further investigation, but prior to removal, after approximately 24 hours, the mechanism inadvertently released. The release occurred while the wires leading to the NEA were being inspected for damage or breaks.

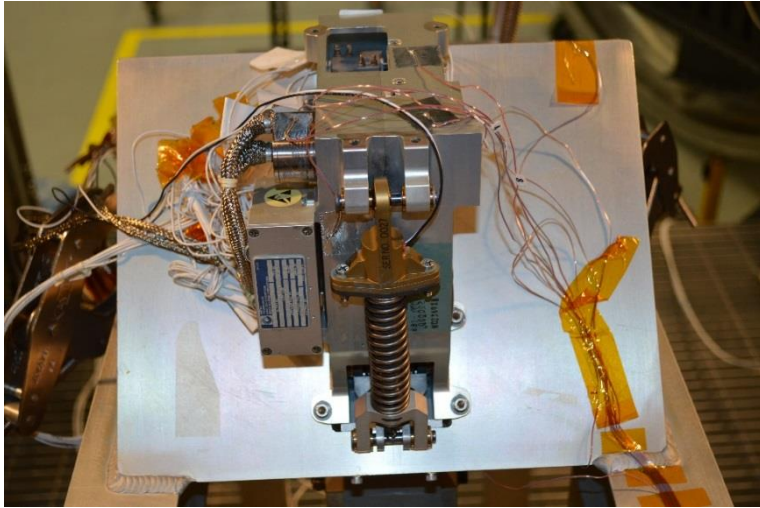

Figure 7. Qualification Capture Latch in CCLR Test Setup

After the NEA released, the unit was again inspected for any debris or other explanation for the delayed release. The capture latch was then removed from the fixture for additional investigation. The secondary release mechanism of the capture latch and the NEA were disassembled and inspected for debris or evidence of jamming. All inspections were performed using visual inspections only aided with simple magnification. No explanation for the jamming was discerned. The portions of the secondary release mechanism that reside in the capture latch housing were also inspected (without disassembly). That portion of the mechanism was free moving and showed no evidence of jamming.

Troubleshooting was performed using shop aids to simulate the secondary release mechanism to validate that the latch functioned properly. Ultimately, a new NEA was installed in the Capture Latch and activated in a test resulting in the mechanism functioning nominally. No satisfactory explanation for the failure was identified during the investigation. After review with the NDS Program, the failure was deemed an unexplained anomaly. Three potential causes for the failure were identified: 1. NEA damaged during environmental testing resulting in failure to release, 2. NEA failed to release due to manufacturing error caused by use of development processes for assembly, and 3. NEA failed to release due to binding/jamming/seizing within the NEA release mechanism. Because the NEA is a simple, reliable mechanism that has been used successfully in many other applications – including numerous space applications, an internal design flaw leading to this failure was considered unlikely. The most probable cause was considered a defect in manufacturing due to the test article being a development unit.

Description of Qualification Test Failure

The second CCLR failure occurred during qualification testing of the capture latch assembly. Similar to the development test, the qualification secondary release test occurred toward the end of the qualification program, to be followed only by the ultimate load test. However, for the qualification testing, the mechanism was tested under the thermal vacuum (cold) conditions. Like the development test, the unit had already been subjected to all other environmental tests, including random vibration. Additionally, the test load was lowered based on updated structural analysis of the worst case undocking conditions. The test setup for the qualification test was identical to flight except that a camera was added inside the thermal vacuum chamber to allow direct viewing of the NEA, and an oscilloscope was used to obtain high speed current data for the performance of the NEA. The test setup is shown in Figure 7.

During the secondary release test when current was applied there was no evidence the release mechanism moved. Additionally the position sensor and the camera showed no discernable movement.

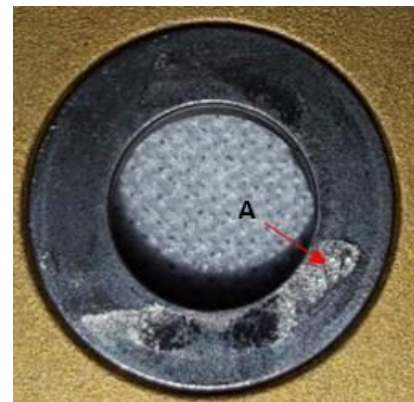

Figure 8. NEA Load Washer

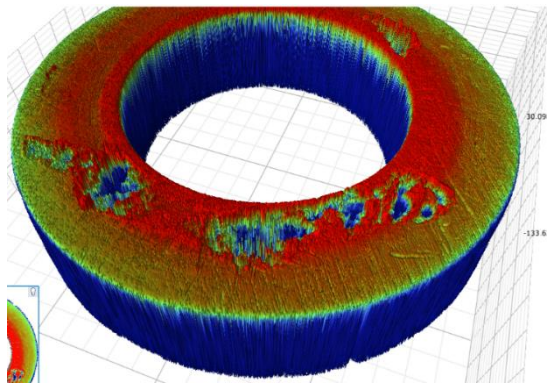

Figure 9. Load Washer Profile

It was then decided that an inspection, including both visual and x-ray of the test hardware must be performed, so the chamber was returned to ambient conditions, which took approximately 24 hours. During the visual inspection, no signs of debris or jamming were observed. However, during the setup for the x-ray imaging, the load released prior to any direct imaging being performed.

Qualification Test Failure Investigation Summary

After the test failure and then inadvertent release, a Failure Investigation Team was convened to investigate and resolve the test failure. The initial goals of the team were to review the development test failure, collect all data relating to the qualification failure, development of a fault tree, and establishing a troubleshooting plan. After

reviewing all data and developing the fault tree, the team determined that the first investigation step should be the teardown and inspection of the secondary release mechanism. The most significant finding of the teardown was the identification of wear marks potentially consistent with galling found on the load washer inside the NEA. The load washer is part of the NEA Cover and has the surface that reacts the load from tension applied to the NEA shaft. Figure 8 shows the load washer and Figure 11 item B shows the approximate position of the load washer in the mechanism. The apparent galling is evident in the silver area on the otherwise black surface of the load washer, as noted as item A in Figure 8.

Corresponding wear marks were also observed on the spool half that was located against this surface. Both parts were examined using a laser profilometer, light microscopy, and a scanning electron microscope to determine whether galling of the wear surfaces had occurred. As shown in Figure 9, the profilometry analysis showed that material on the load washer was displaced and removed. The light microscopy measurement confirmed the presence of fretting and galling, as shown in Figure 10. From these results, the investigation team concluded that the most likely cause of the failure to release was galling of the load washer to the spool inside the NEA. The team’s next task was to determine the cause of the galling.

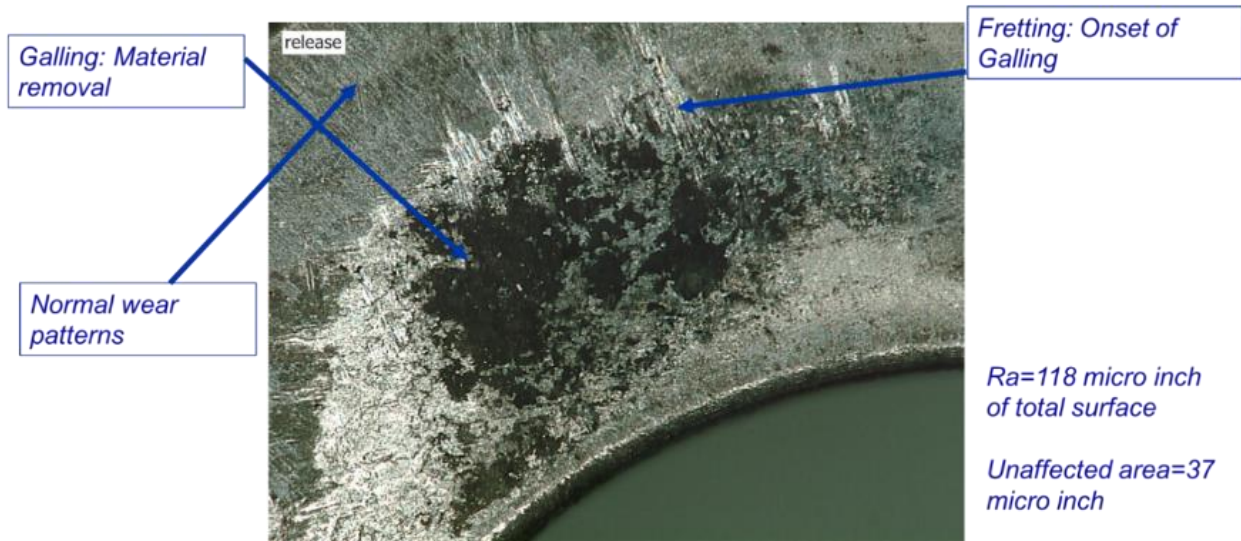

Figure 10. Load Washer Light Microscopy

The investigation into the galling covered many aspects of the design and test for the NEA and Capture Latch, but immediately focused on random vibration testing as the most likely source. It was proposed that free play in the secondary release mechanism along the pin axis could have permitted the secondary release mechanism to move excessively during vibration testing, causing the spool to move relative to the load washer. With enough motion, this could remove all the dry film lubrication coating, and allow galling between the two surfaces. The design of the mechanism included free play along the pin axis to facilitate assembly under worst case tolerance conditions. Additionally, the NEA was not preloaded. To test this theory the Development Capture Latch was reassembled to be subjected to a repeat of the random vibration test and secondary release test. During the testing, high speed video was used to capture the dynamics of the secondary release mechanism movement.

This test was informative, showing that the motion of the mechanism was extremely violent, subjecting it to nearly continuous shock loads as the mechanism shifted between the hard stops on either side of the free play. This motion was especially evident during testing in the axis parallel to the pins. Following the completion of the vibration testing, the unit was subjected to a Secondary Release Test, which it passed. The NEA was disassembled and similar wear was observed. Although the failure could not be duplicated, the excessive wear was duplicated and the test was considered successful.

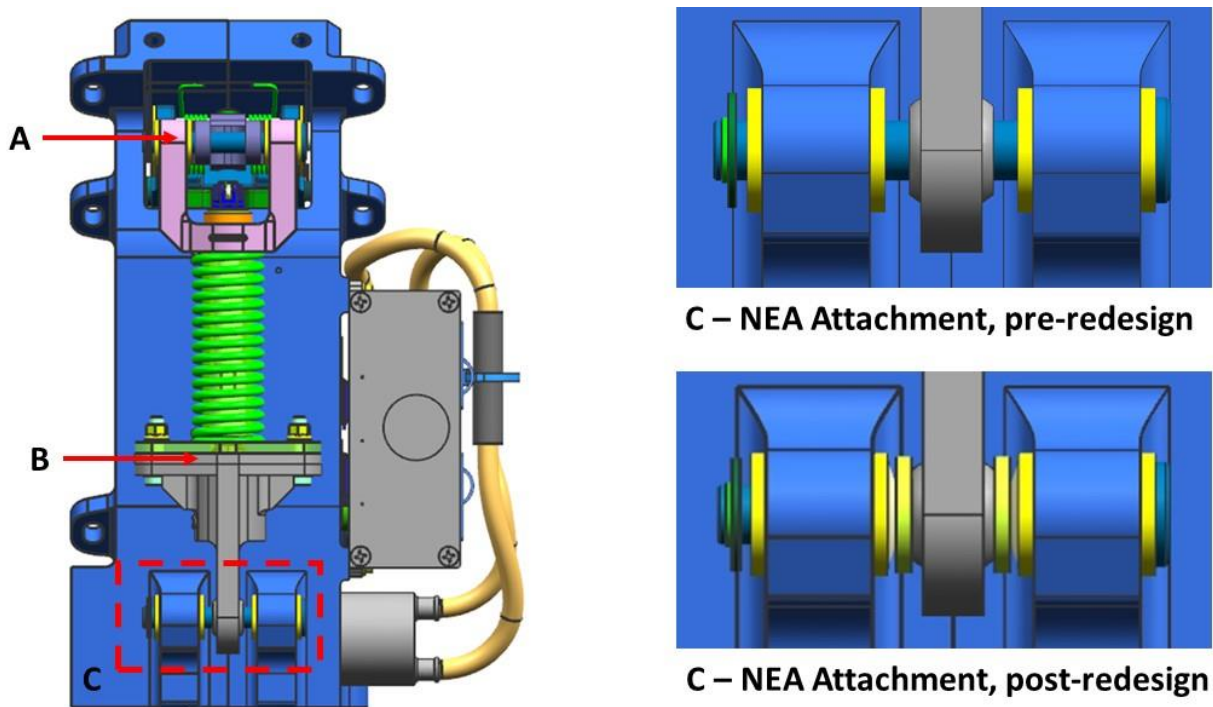

Figure 11. CCLR Detail

Based on these results it was determined that the mechanism should be redesigned to remove free play. The design improvement was implemented by installing flat washers and Belleville washers on the pins to remove all gaps, with a slight preload, as shown in Figure 11. Additionally, the NEA was given a small preload. The development capture latch was rebuilt with the redesigned configuration and subject to the same set of tests. The redesigned configuration showed no signs of the galling/excess wear. The Qualification Capture Latch was then rebuilt per the new configuration and subjected to random vibration testing and a secondary release test. The unit passed and was shown to have no excessive wear during a post-test inspection.

Lessons Learned

Avoid Loosely Constrained Parts

Loosely constrained parts can be damaged when subjected to vibration or dynamic loading events. Avoid loosely constrained parts whenever possible.

Thermal Stresses In Potted Parts

Thermally induced stress in potted parts due to differences in CTE between the potting material and the supported parts can be significant.

Fully Address Failures During Development Testing

Not fully addressing or investigating failures during development testing can allow design defects to propagate into the flight design and production..

Watch the Test Whenever Possible

The Test Engineers/Technicians may not see the same things that a designer would. When the design engineers observed the vibration test for the first time, it was very clear that the motion induced by the test was unacceptable. If they had observed the development random vibration test, the issue may have been addressed much sooner in the design.

Use Caution with Commercial Off The Shelf (COTS) Parts

Using COTS parts in a design results in a less rigorous verification of the part performance and suitability for use in the desired application. When using COTS parts, or tailored COTS parts, the designer is responsible for ensuring that all critical interfaces between the COTS part and the assembly are compatible.

Conclusions

After overcoming the difficulties discussed in this paper, the Capture Latch Assemblies for the NDSB1 were successfully designed, qualified, and manufactured/tested. A total of twelve flight assemblies – representing four NDSB1 units – have been completed. A number of lessons were learned during this process which will be applied to future CLA production and development as part of the next version of the NDS – the NDS Block 2, which will be used with the Orion and Deep Space Gateway programs.

References

1. Swan, W, "The Apollo –Soyuz Test Project Docking System," *10th Aerospace Mechanism Symposium*, NASA TM 33-777, Pasadena, CA., 1976, pp. 29, 36.
2. Cook, J., Aksamentov, V., Hoffman, T, & Bruner, W. "ISS Interface Mechanisms and their Heritage", *AIAA Space 2011*, pp. 24.
3. Dick, B., Oesch, C., and Rupp, T., "Linear Actuator System for the NASA Docking System," *17th European Space Mechanisms and Tribology Symposium*.