

Recent NASA Wake Surfing Flight Research

EXPERIMENTAL MEASUREMENTS OF FUEL SAVINGS DURING AIRCRAFT WAKE SURFING

CURT HANSON, JOE PAHLE, JAMES REYNOLDS, STEPHANIE ANDRADE, NELSON BROWN
NASA ARMSTRONG FLIGHT RESEARCH CENTER

EXPERIMENTAL MEASUREMENTS OF PASSENGER RIDE QUALITY DURING AIRCRAFT WAKE SURFING

CURT HANSON, STEPHANIE ANDRADE, JOE PAHLE
NASA ARMSTRONG FLIGHT RESEARCH CENTER

introduction



Wake Surfing Background



WAKE SURFING EXTRACTS ENERGY FROM THE UPWASH OF ANOTHER AIRCRAFT'S WAKE VORTEX.

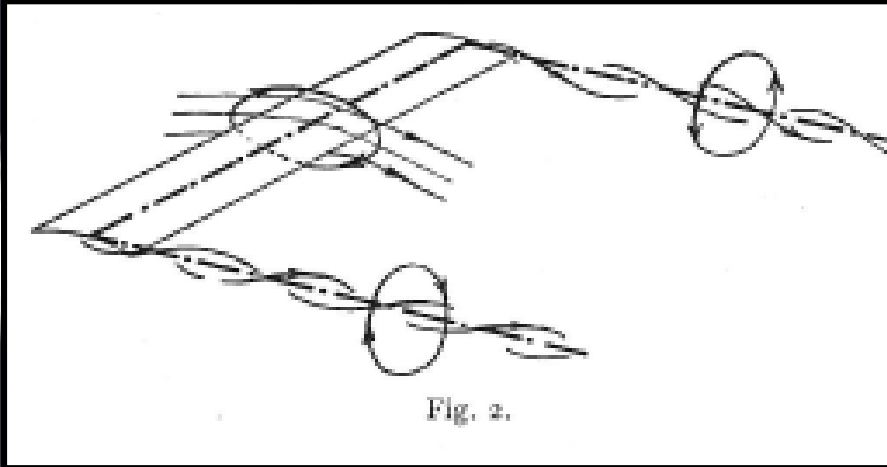

Fig. 2.

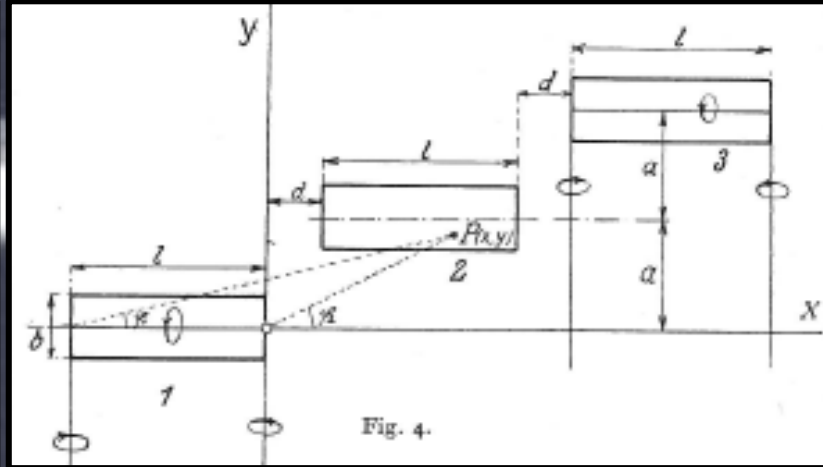

Fig. 4.

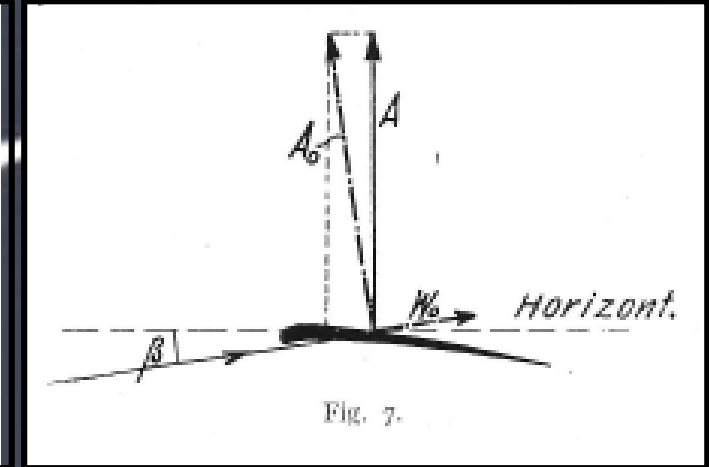
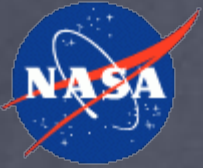

Fig. 7.

Wieselsberger, C., "Contribution to the Explanation of Angled Flight Patterns of Some Migratory Birds," 1914.

REDUCE DRAG, FUEL USE, AND EMISSIONS

- AIR CARGO OPERATORS
- CIVILIAN PASSENGER AIRCRAFT PAIRS
- DISSIMILAR AIRCRAFT PAIRINGS
ex: fighter-tanker missions
- 3-SHIP STAGGERED V FORMATIONS
- 4+ AIRCRAFT FORMATIONS
 - string stability
 - downstream wake effects
- HALE
- SMALL UAVS
Q: what is the lower size limit?



Prior Wake Surfing Flight Research

1986

German Institute for Fluid Mechanics



2001

NASA Dryden Flight Research Center



2001

US Air Force Test Pilot School



2003

NASA Dryden Flight Research Center



2010

NASA DFRC / USAF FTC



2012 - 2013

DARPA / AFRL / Boeing



- Proof of concept
- No data link
- 10% power reduction
- Rudimentary peak-seeking control

- Research data link and autopilot
- 14% fuel savings (manual)
- Validated system requirements
- Detailed wake effect mapping

- Manually flown
- No data link or autopilot
- 9% fuel savings (2-ship)
- Inconclusive 3-ship evaluation

- Manually flown
- No data link or autopilot
- 29% fuel savings
- Promising dissimilar aircraft test

- Proof of extended formation concept
- Production military data link and autopilot
- 7-8% fuel savings (manual)

- Modified C-17 autopilot
- Production military data link
- 10% fuel savings (autopilot)
- Wake avoidance algorithms

Close Formation Flight Research

Extended Formation Flight Research

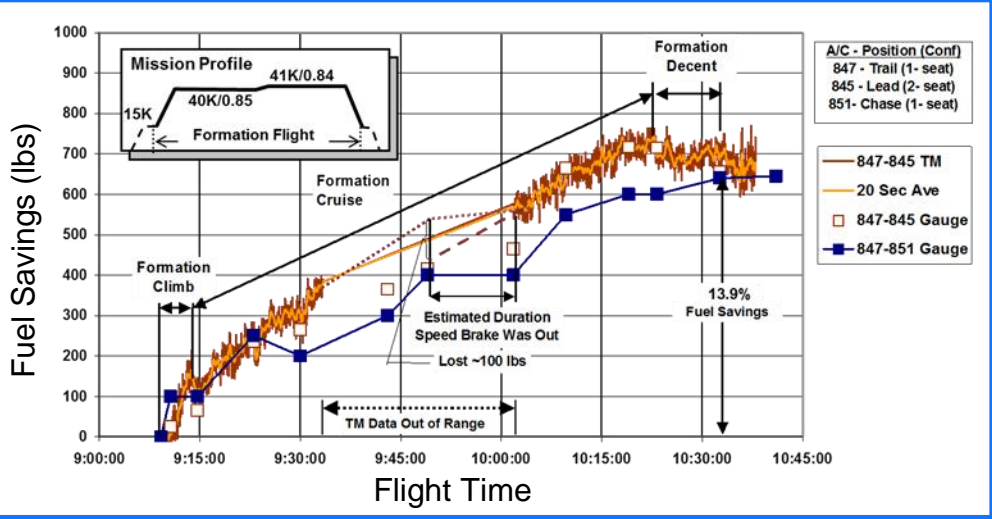

Ray, Ronald J., et al, "Flight Test Techniques Used to Evaluate Performance Benefits During Formation Flight," 2002

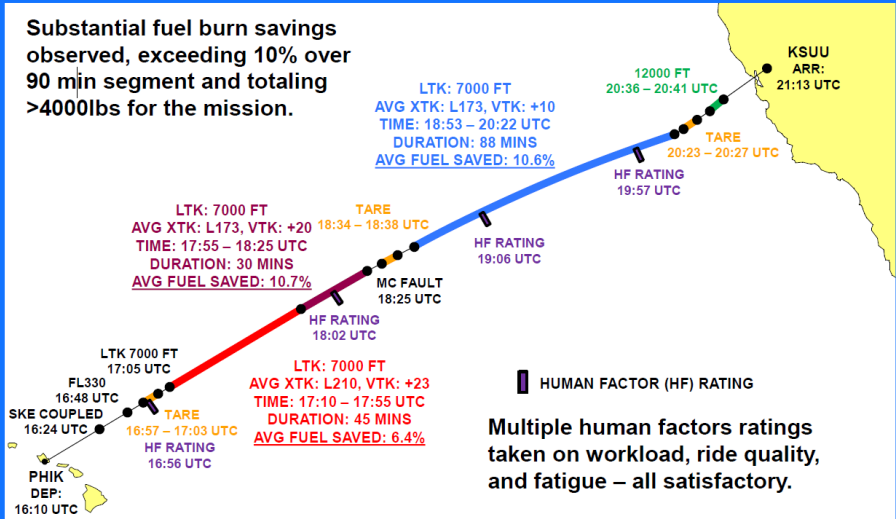

Bieniawski, Stefan R., et al, "Summary of Flight Testing and Results for the Formation Flight for Aerodynamic Benefit Program," 2014



Wake Surfing Challenges

DR. ERBSCHLOE, USAF AMC CHIEF SCIENTIST (2008):

"WE WILL ONLY BE INTERESTED IN FORMATION FLYING FOR AERODYNAMIC BENEFIT IF IT IS:

- SAFE.
- AIRCREW FRIENDLY.
- AIRCRAFT FRIENDLY.
- MAKES BUSINESS SENSE.
- MAKES OPERATIONAL SENSE."

OTHER CHALLENGES IDENTIFIED BY THE USAF:

- PILOT TRAINING
- PILOT TACTICAL DUTY DAY RESTRICTIONS
- EQUIPAGE FOR AIRCRAFT OTHER THAN THE C-17
- DOMESTIC AND FOREIGN AIR TRAFFIC CONTROL



INDUSTRY PERSPECTIVES, WAKENET USA 2013:

- AIR CARGO COMPANIES
- MAJOR CARRIERS AND REGIONAL AIRLINES
- AIRLINE PILOT ASSOCIATION

CHALLENGES IDENTIFIED BY INDUSTRY:

- LACK OF CIVILIAN AIRFRAME DATA
- PASSENGER DISCOMFORT
- WAKE CROSSING PREVENTION
- COST OF EQUIPAGE
- AIR TRAFFIC CONTROL PROCEDURES
- FAA APPROVAL



NASA G-III Wake Surfing Flight Experiment

TRAIL AIRPLANE:

- NASA C-20A (G-III MILITARY VARIANT)
- PRODUCTION AVIONICS AUGMENTED WITH:
 - EXPERIMENTAL PROGRAMMABLE AUTOPILOT
 - PILOT TABLET DISPLAYS
 - COMMERCIAL ADS-B IN
- VIDEO RECORDING OF FUEL FLOW
- CABIN VIBRATION AND NOISE SENSORS



LEAD AIRPLANE:

- NASA G-III
- PRODUCTION AVIONICS WITH ADS-B OUT
- CABIN VIBRATION SENSORS



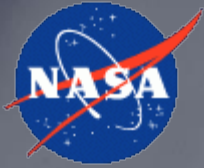

ADS-B Enabled Experimental Autopilot

1090 MHz ADS-B Data Link

- Non-secure data link
- Broadcast twice-per-second at random variations
- Horizontal resolution ~16.7 feet / 1 knot
- Vertical resolution ~25 feet / 64 ft per min
- Accuracy dependent on transmitting avionics
- No wind or weather information

Research Autopilot

- Wake drift and descent predictions
- Wake-relative navigation
- Trajectory control
- Analog ILS localizer and glideslope commands
- Throttle cues to pilot display

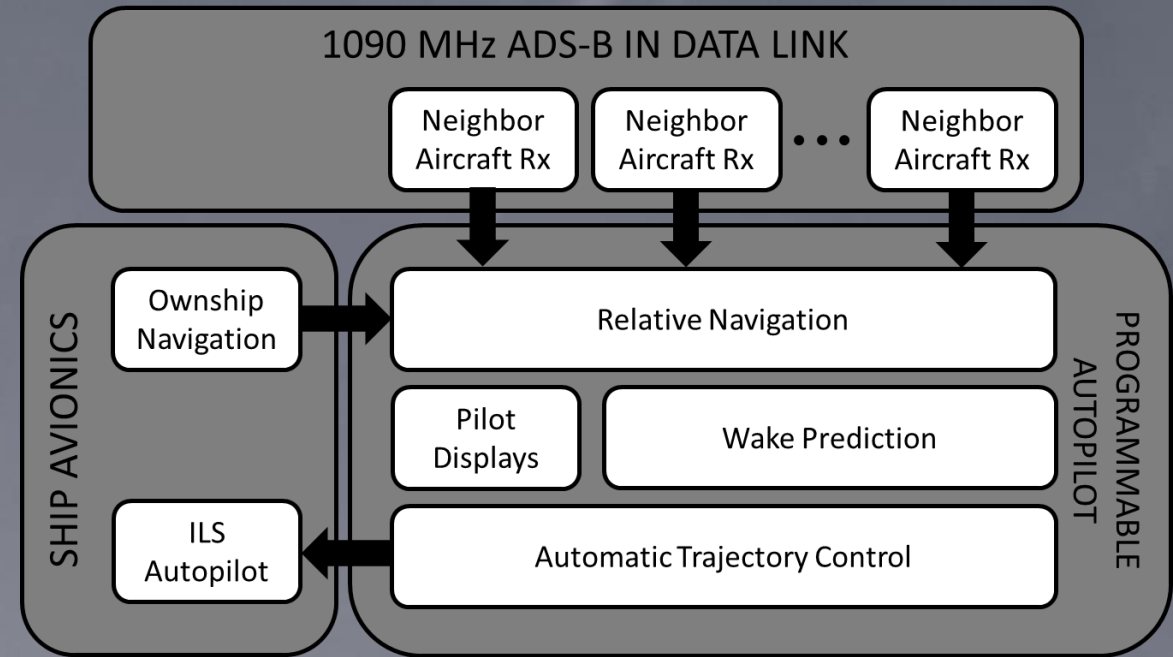

Operator Interfaces

- Lead aircraft selection
- Controller gains and parameters
- 3-axis wake-relative position commands
- Arm / engage / disengage



Experiment Conditions

TEST OPERATIONS:

- MACH 0.7, 35,000 FEET
- 4000 FEET IN TRAIL
- 30-40 MINUTE TEST LEGS
- W-291 RESTRICTED AIRSPACE OVER THE PACIFIC OCEAN

TEST CONDITIONS

- DAY VMC
- CALM TO LIGHT TURBULENCE
- CONTRAILS PREFERRED BUT NOT REQUIRED





Experiment Methodology

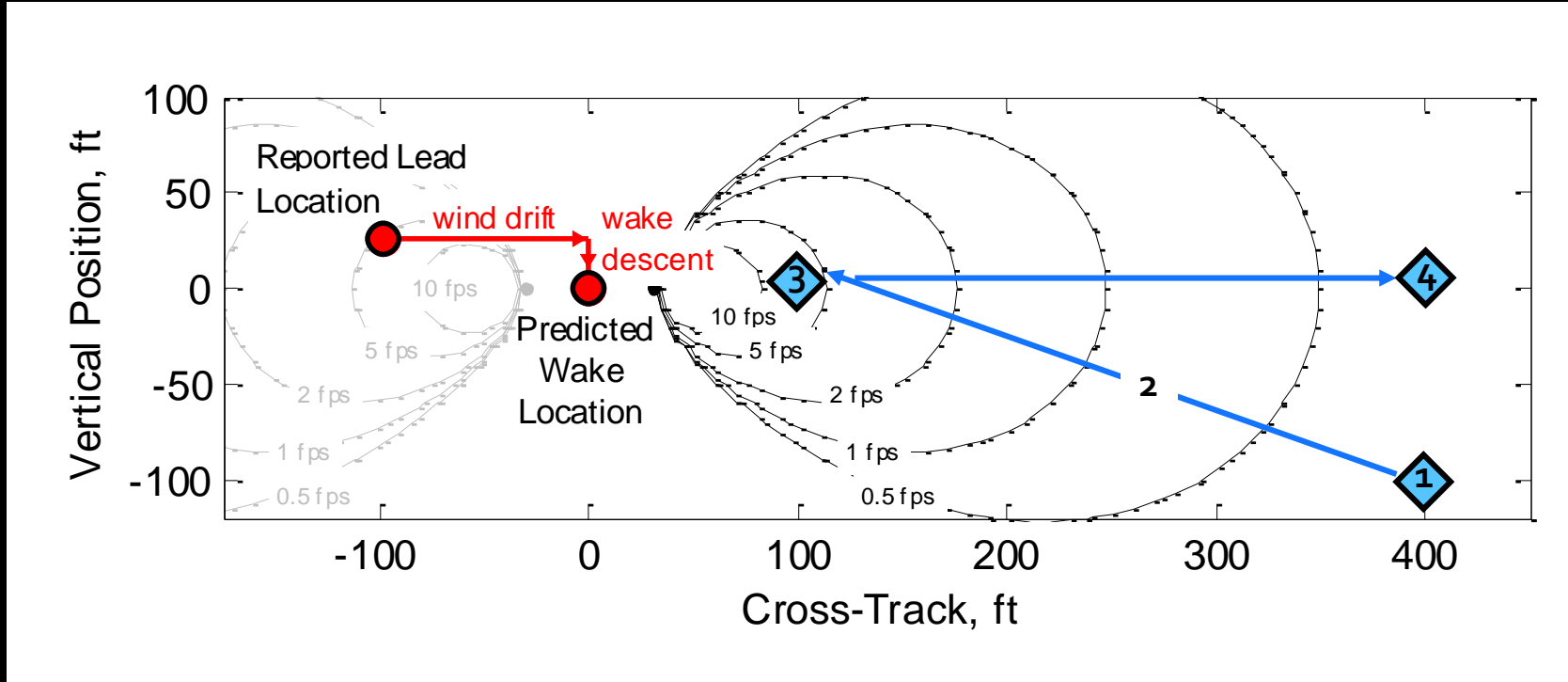

The autopilot computes a **wind-** and **descent-corrected** trajectory for the trail airplane. This trajectory is relative to the lead airplane's wake.

One knot of error in cross-track wind speed adds 10 ft of error to the predicted wake location.

TEST METHOD:

1. WAKE-FREE TARE
(MINIMUM OF 3 MINUTES)
2. WAKE INGRESS / MAPPING
3. STABILIZED WAKE SURFING:
PERFORMANCE DWELL AND
RIDE QUALITY EVALUATION
(MINIMUM OF 5 MINUTES)
4. WAKE-FREE TARE
(MINIMUM OF 3 MINUTES)

performance benefits



Fuel Flow Estimation

$$\hat{m}_0(m) = \underbrace{\dot{m}_R(m)}_{\text{Reference}} - \underbrace{\left(\frac{\partial \dot{m}}{\partial V}\right) \Delta V}_{\text{Airspeed Change}} - \underbrace{\left(\frac{\partial \dot{m}}{\partial \dot{V}}\right) \dot{V}}_{\text{Rate of Change}}$$



cockpit fuel flow meters

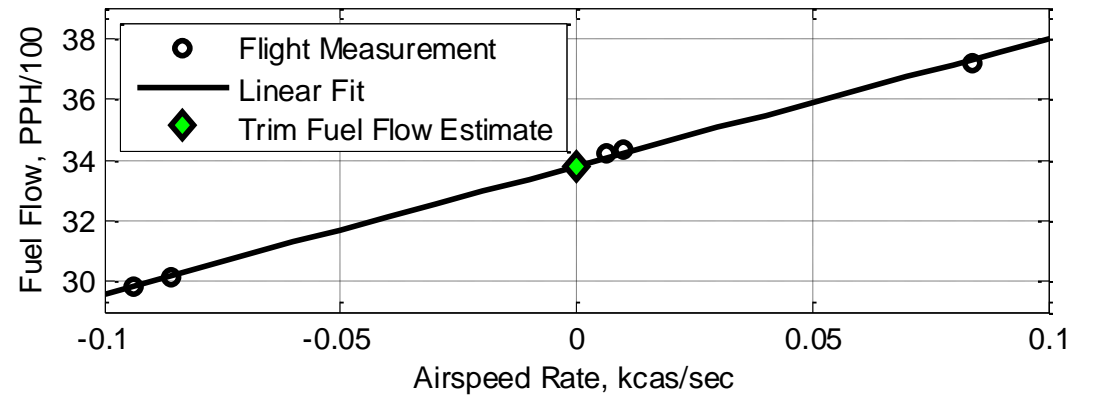
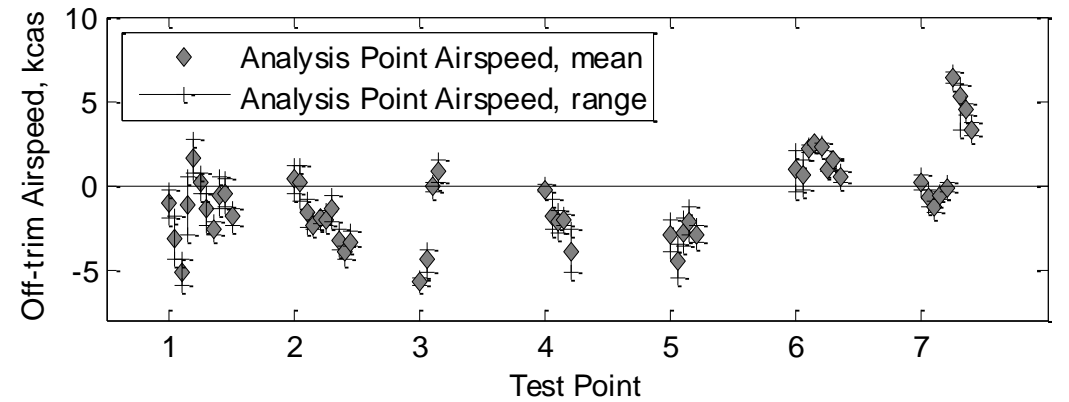



Fuel Flow Estimation

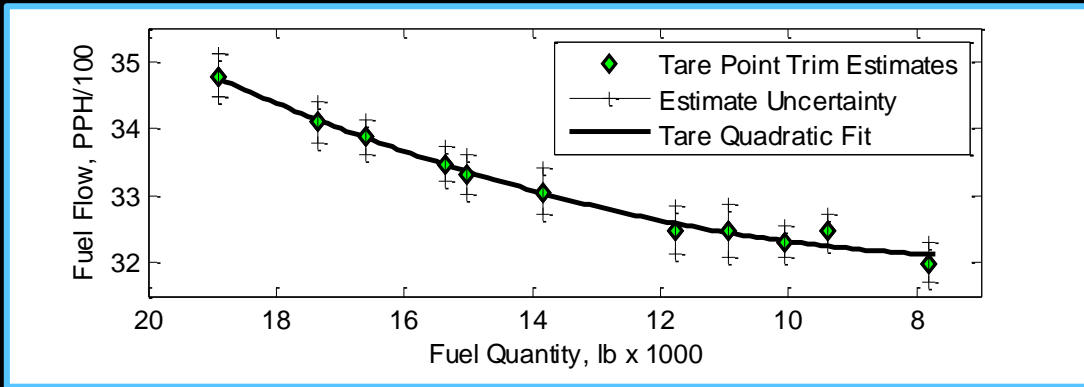

tare fuel flow vs. fuel quantity

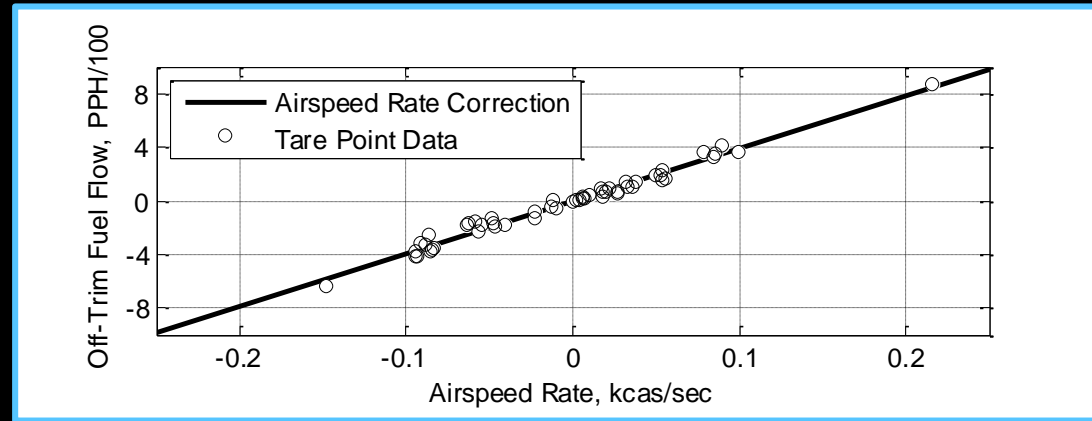

value of $\left(\frac{\partial \dot{m}}{\partial \dot{V}}\right)$ for all tare points

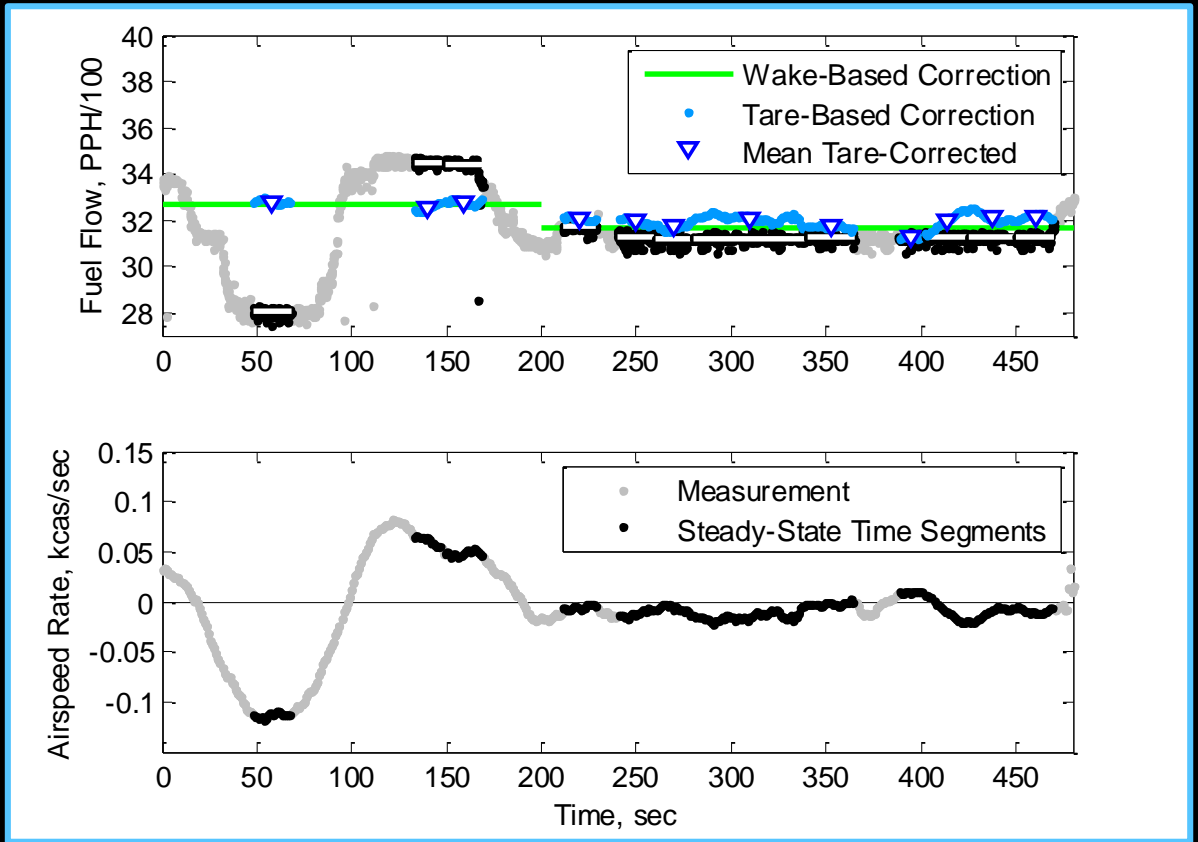

Example fuel flow corrections for in-wake performance point. (local linear fit vs. tare-based correction)



Fuel Flow Reduction Results

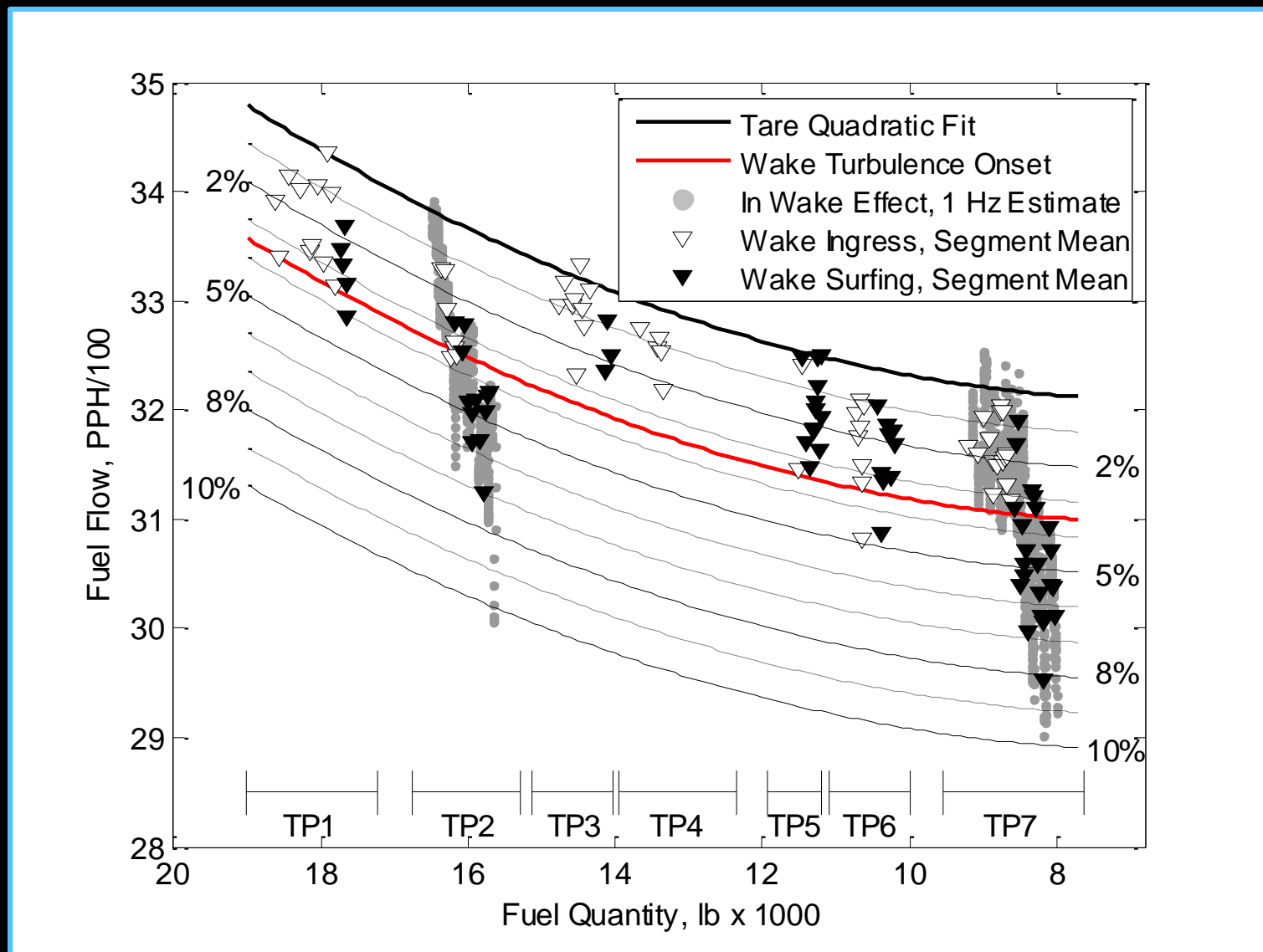

Seven test points were completed on the final flight.

▼: Points of constant throttle setting (20-plus seconds).

Wake ingress was stopped when wake effects (**rumbling**) were felt in the cabin. Post-flight analysis showed this occurred around 3.5% fuel flow reduction.

This potentially limited the maximum measured benefit.



Fuel Flow Reduction Results

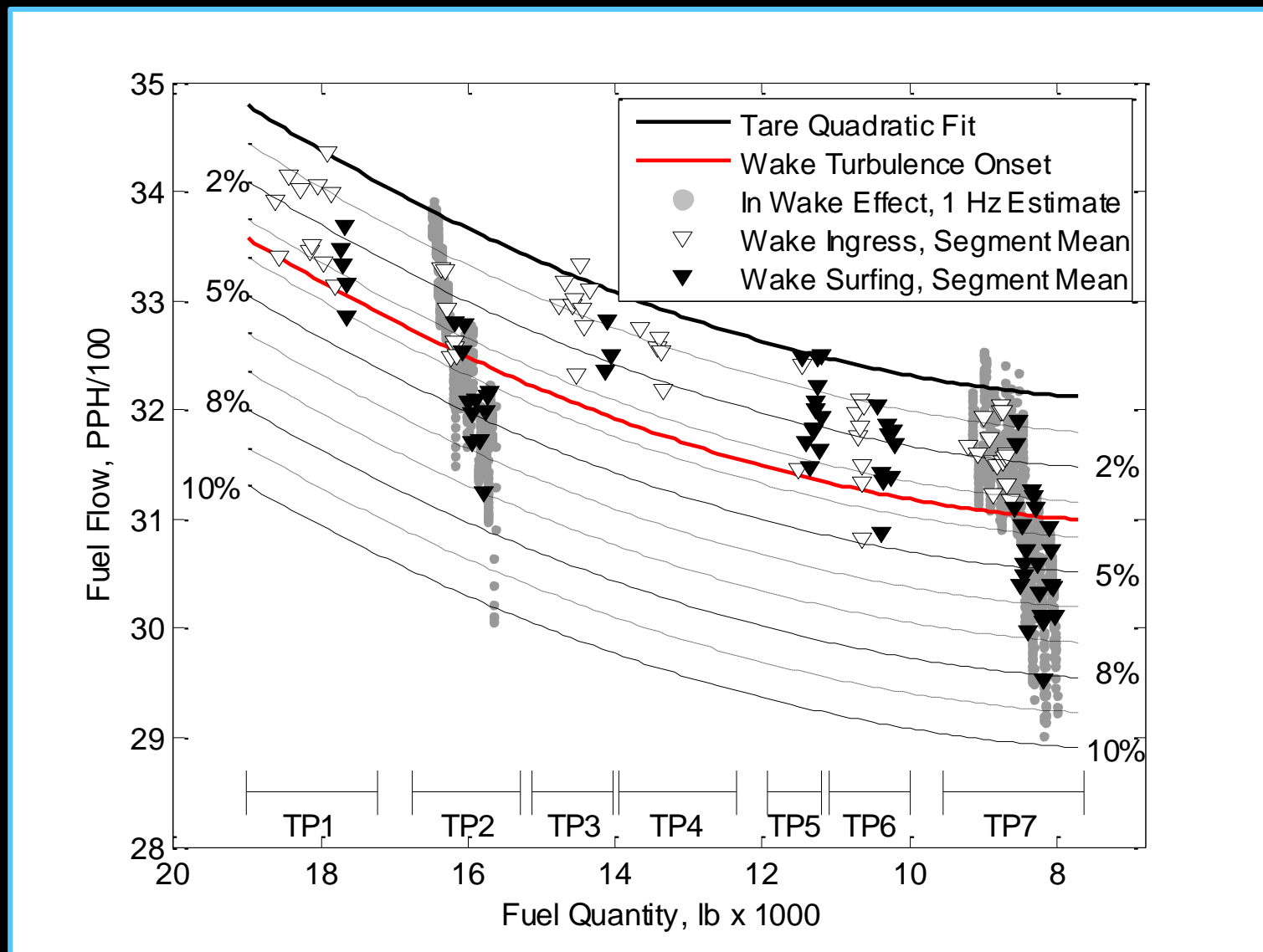

The steep gradient of wake effects vs. position prevented the controller from stabilizing at a single location within the wake for extended periods.

Two of the test points (2 and 7) significantly exceeded the 3.5% ride quality threshold.

A maximum performance benefit of >8% was achieved briefly, consistent with previous wake surfing results.



Wake Effect Map

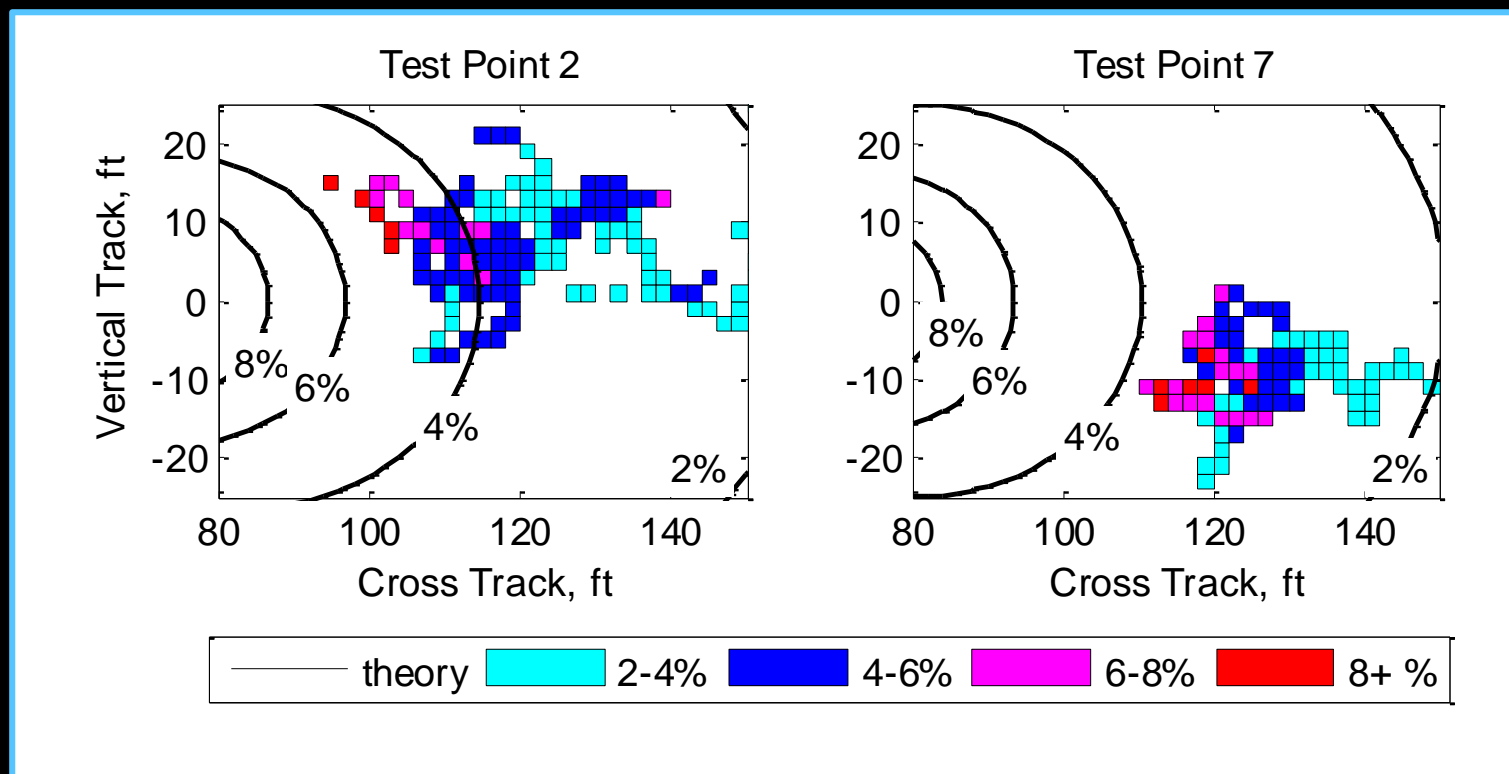

An independent measure of the wake location was unavailable for verification of the wake prediction algorithm.

In general, the largest benefits were measured closest to the predicted core location.

The gradients of the flight measurements appear to be more steep than predicted.



Secondary Effects

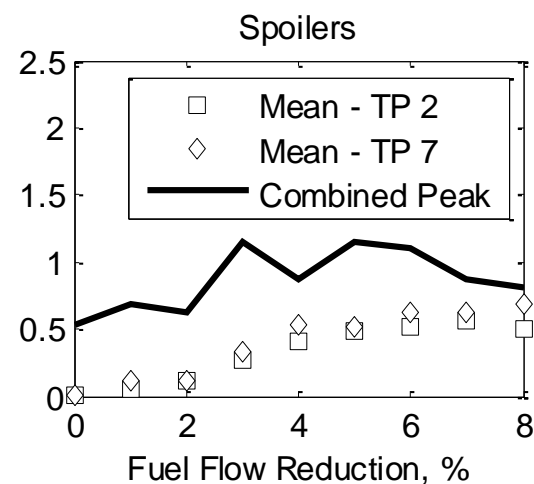
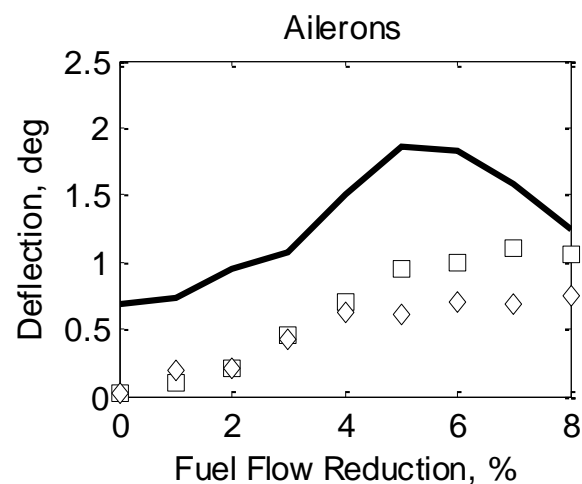
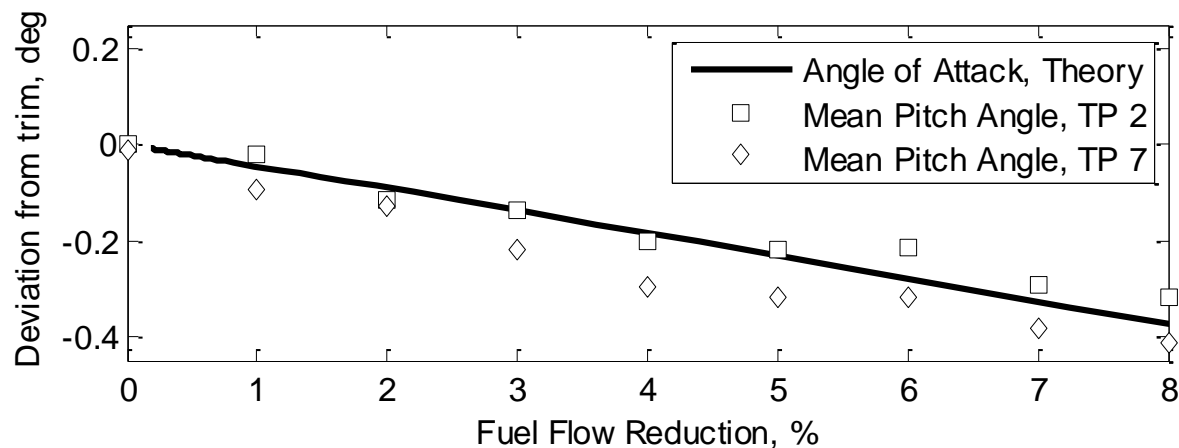

Pitch Trim

Wake-induced drag savings are accompanied by a reduction in trim angle of attack. The flight-measured change in pitch trim vs. fuel flow reduction matches theoretical predictions.

Roll Trim

The wake field produces an asymmetric lift distribution across the wing, resulting in increased roll trim with higher fuel savings. The measured aileron and spoiler deflections show a correlation with measured fuel flow reduction.

passenger ride quality



Passenger Ride Quality: Cabin Vibration

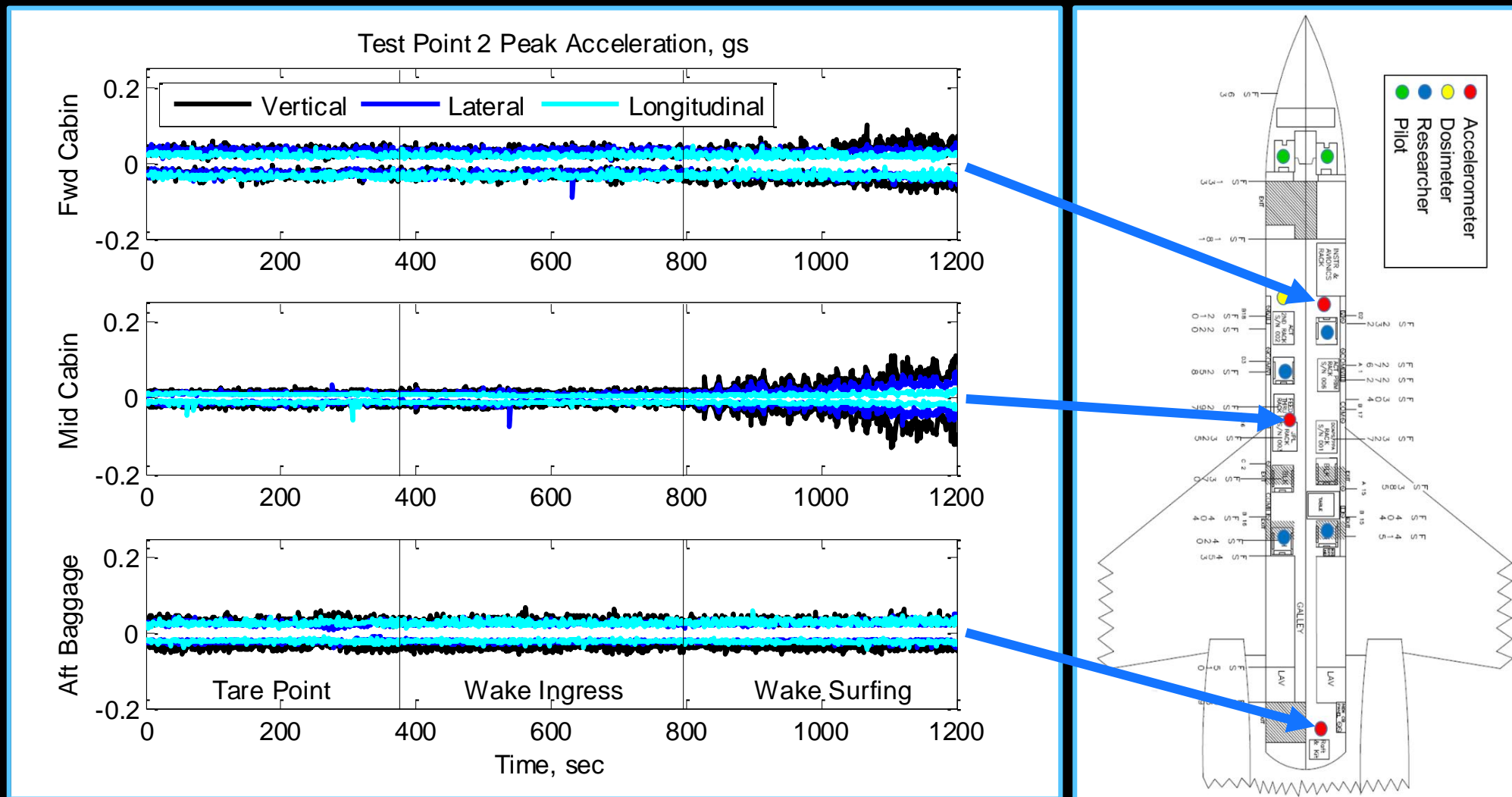

- Occurred in the strongest part of the wake
- Strong variation with fore-aft cabin location
- Described as “rumbling”, compared to light turbulence or a driving on a washboarded road



Passenger Ride Quality: Cabin Vibration

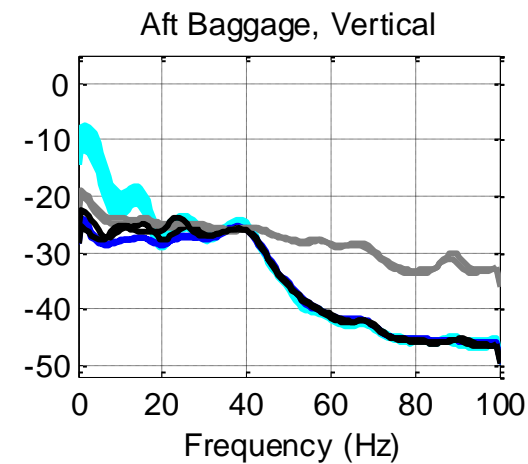
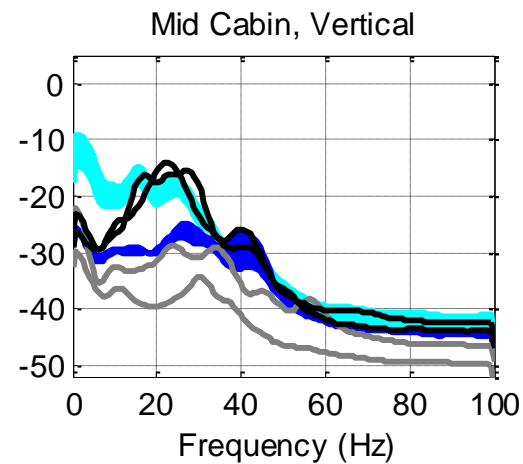
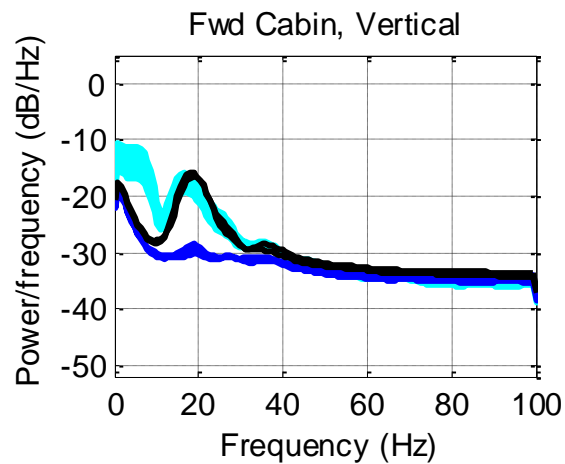
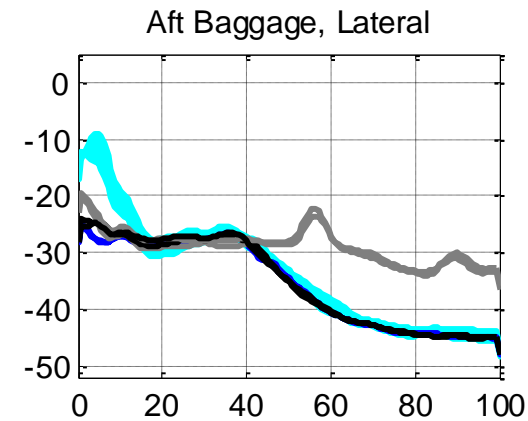
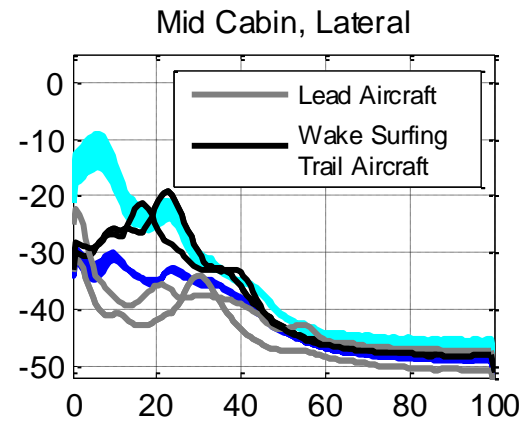
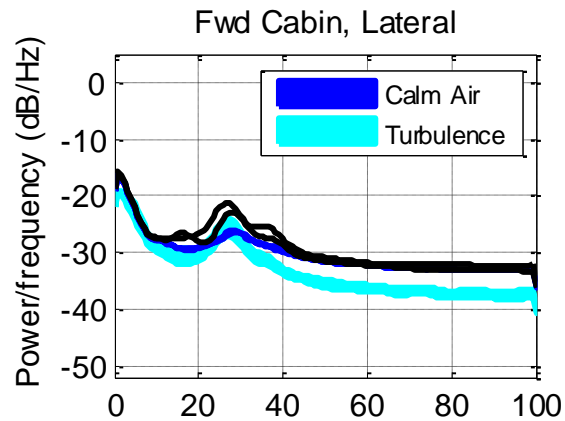

- Wake-induced vibrations are similar to those of light turbulence at higher frequencies
- Light turbulence contains low frequency content not found in the wake
- Cabin vibrations on the lead airplane during wake surfing were similar to non-turbulent conditions, suggesting measured effects on the trail airplane were due to flight within the wake



Passenger Ride Quality: Cabin Noise

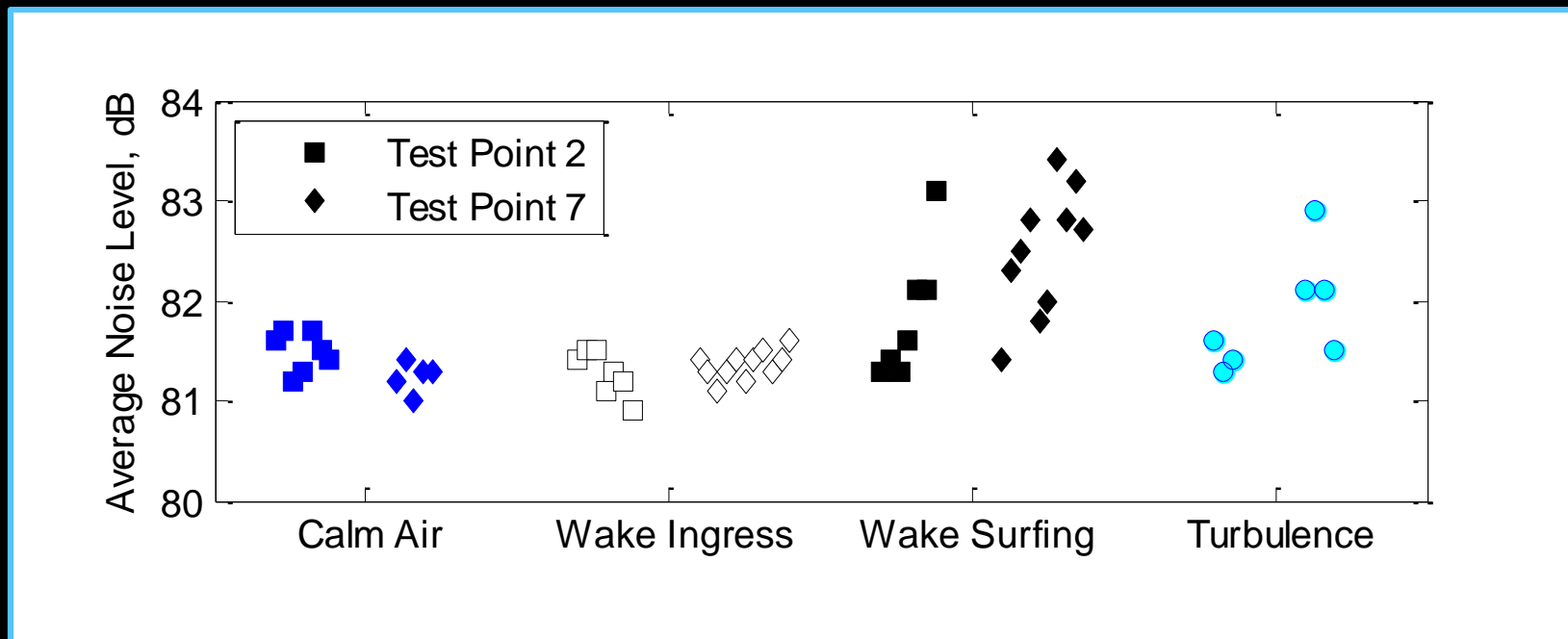

- Slightly increased cabin noise levels were recorded during wake surfing, as compared to flight in calm air and in the weaker portions of the wake.
- A similar increase in noise was also recorded during the more severe of the two “light turbulence” turbulent tare points.



Dosimeter noise recorder, trail aircraft cabin installation



NASA Passenger Ride Quality Metric

In the 1970s, Jack Leatherwood and others at NASA LaRC conducted a series of studies to develop a criteria to predict passenger discomfort due to vibration and noise.

- Vibration Tests
 - 2200 test subjects
 - motion simulator fitted with six tourist-class aircraft seats
 - 10 - 15 second excitations
 - lateral, vertical, longitudinal, roll, and pitch vibrations
 - rated as "comfortable" or "uncomfortable"
- Noise and Vibration Tests
 - 60 test subjects
 - combinations of noise and vibration
 - 4 sound levels, 6 octave bands

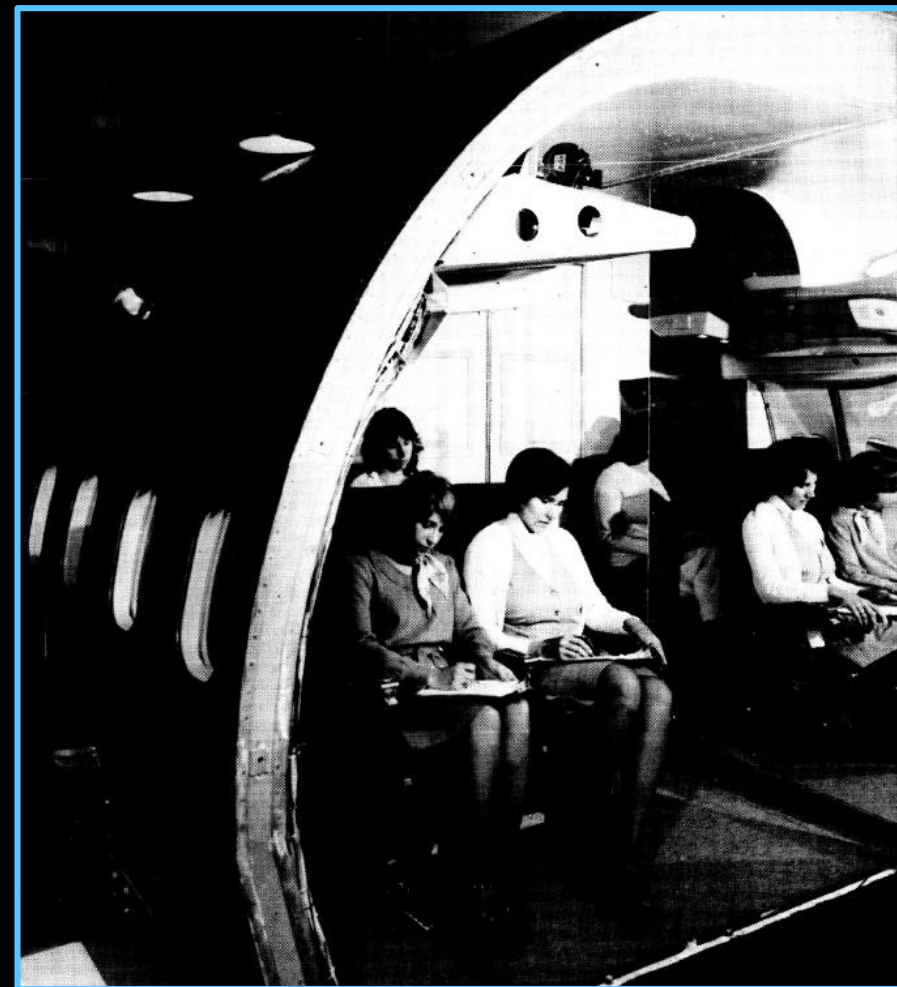

from "Human Discomfort Response to Noise Combined With Vertical Vibration," Leatherwood, April 1979



NASA Passenger Ride Quality Metric

- Frequency-weighted acceleration measurements are combined to form a Discomfort Metric: DISC.
- For sinusoidal vibrations, the DISC metric was developed with the following excitations:

Vertical: 1 - 30 Hz | 0.04 - 0.34 g

Lateral: 1 - 10 Hz | 0.04 - 0.34 g ← the lateral 10-Hz weighting was applied to all data above 10 Hz

Roll: 1 - 4 Hz | 0.23 - 2.62 rad/s²

- A DISC of 1 predicts that 50% of passengers will find the ride uncomfortable.
- Note: Leatherwood's **Noise** and **Duration** corrections were not applied for the following results.

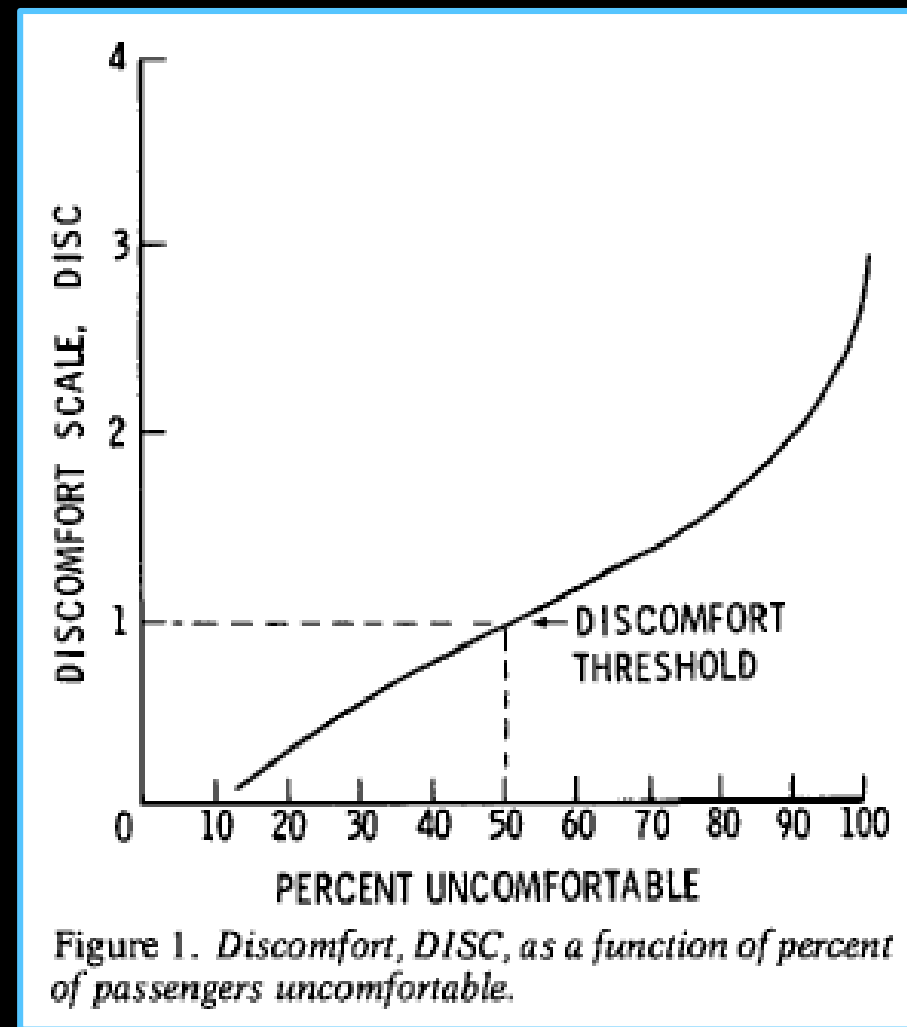

from "A Design Tool for Estimating Passenger Ride Discomfort Within Complex Ride Environments," Leatherwood, Dempsey, and Clevenson, Human Factors, June 1980



NASA Passenger Ride Quality Metric

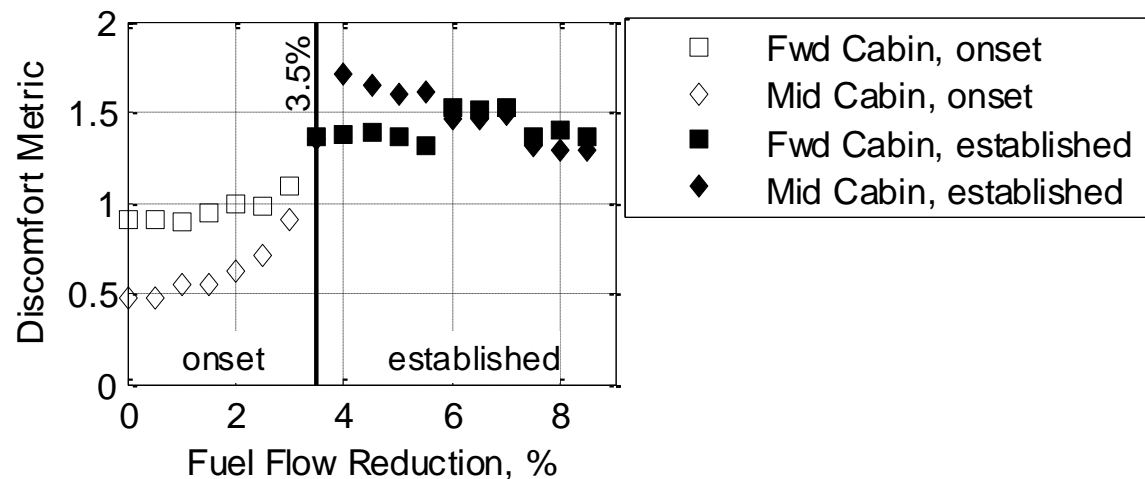

- DISC metric values were calculated for lateral and vertical vibrations recorded at the forward and mid-cabin locations.
- DISC plotted vs. fuel flow reduction shows the gradual onset of wake discomfort below 3.5%.
- Above 3.5% the DISC is consistently high.
- Using the Leatherwood criteria, the peak DISC values calculated at the two cabin locations during wake surfing fall within the region of values measured for light turbulence.
- Even in calm air, the DISC values are quite high, suggesting this metric may over-predict passenger discomfort.

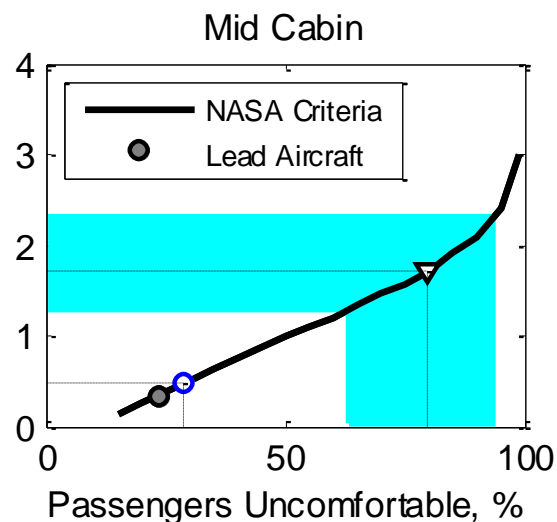
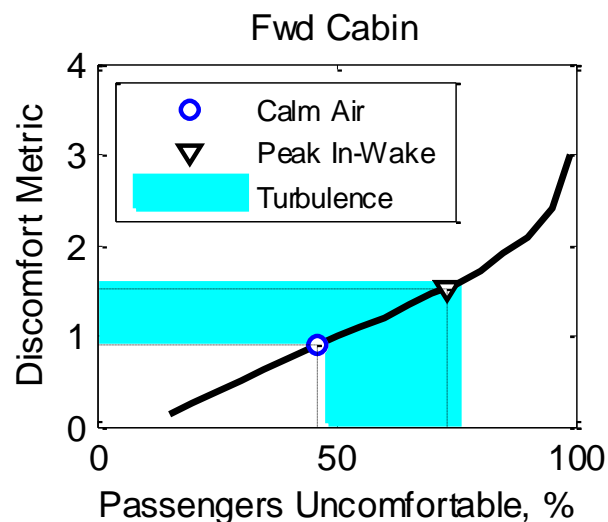



ISO-2631 Passenger Ride Quality Metric

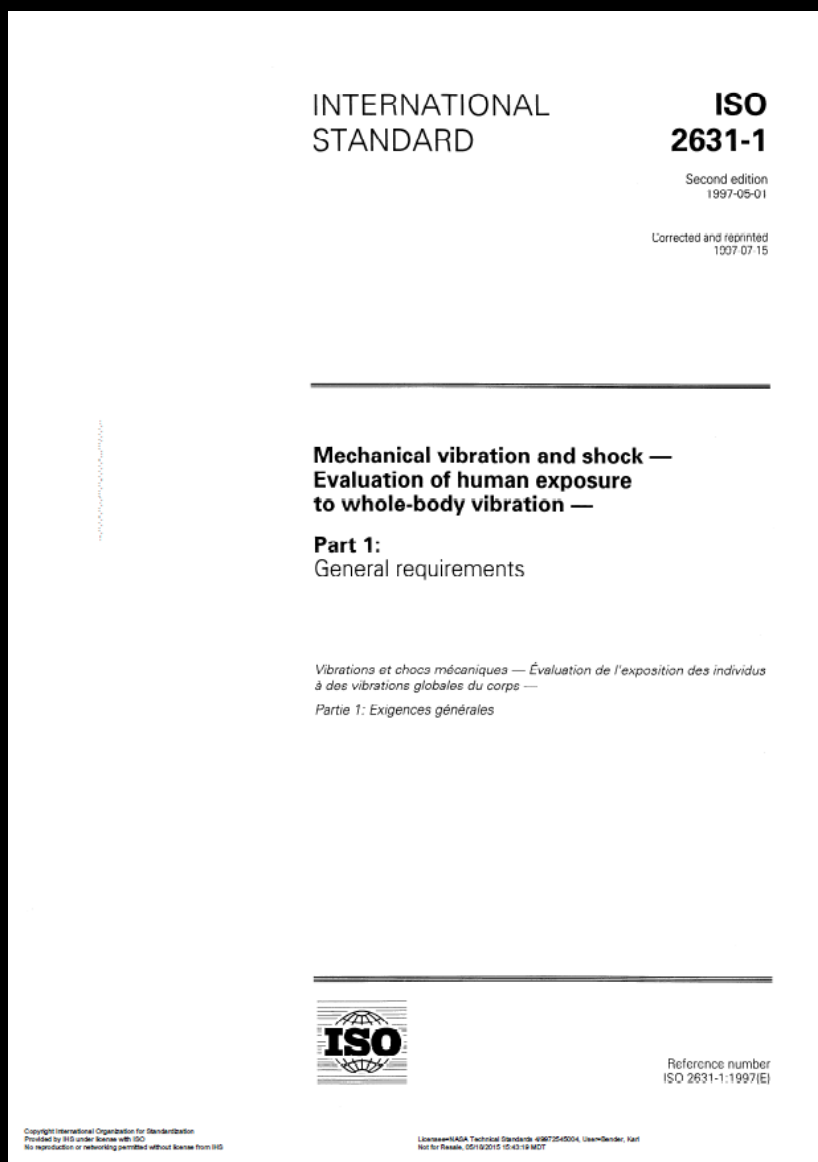

- Frequency-weighted acceleration measurements are combined to form a Vibration Dose Value: VDV.
- The ISO metric addresses the following frequency ranges:
 - 0.5 - 80 Hz: **health, comfort, and perception**
 - 0.1 - 0.5 Hz: **motion sickness**
- VDV-based human comfort rating predictions increase with exposure time raised to the $\frac{1}{4}$ power.
- Motion sickness increases with the square root of the exposure time.
- The ISO standard gives a relationship between VDV and descriptive “likely reactions” in terms of comfort value.



ISO-2631 Passenger Ride Quality Metric

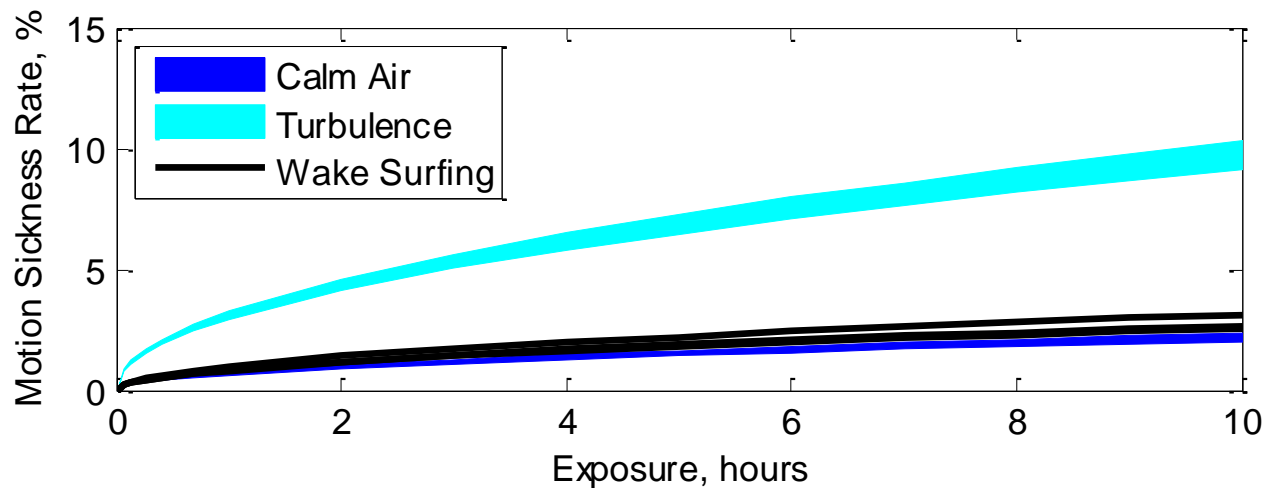
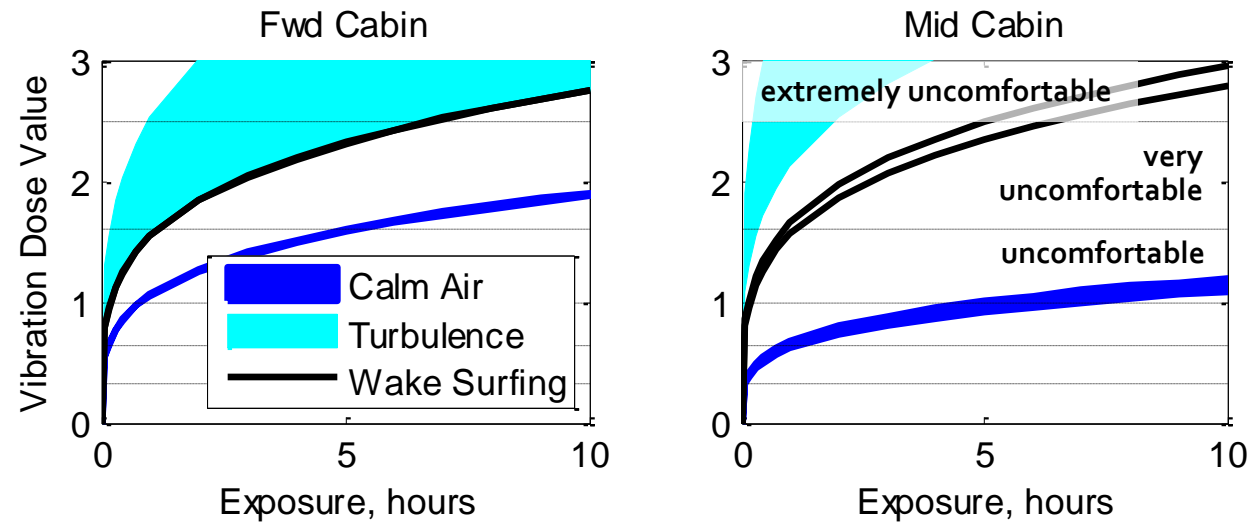

- The ISO metric predicts increased passenger discomfort due to wake surfing vs. calm air, although not as severe as light turbulence.
- Even the calm air predictions are solidly 'uncomfortable' for flights longer than 5 hours, which may indicate over-prediction of passenger discomfort by this metric.
- The ISO metric predicts no appreciable increase in passenger motion sickness due to wake surfing vs. flight in calm air, and significantly less motion sickness than flight through light turbulence.



Passenger Ride Quality Survey

Summary of the post-flight questionnaires:

- 9 participants (2 pilots, 6 engineers, 1 videographer); majority are frequent flyers
- Wake Surfing Comfort Response:
 - "Comfortable": 45% (4 of 9)
 - "Neutral": 45% (4 of 9)
 - "Uncomfortable": 10% (1 of 9)
- 10% reported "Writing" would be difficult
- 33% reported "Sleeping" would be difficult

Comments:

- "Similar to light turbulence"
- "Rhythmic, pulsing sound - not unpleasant but noticeable"
- "Like driving over a slightly-washboarded road"



- "I found the view of contrails outside my window unsettling"
- "The appearance of the wake was larger than I had originally imagined"

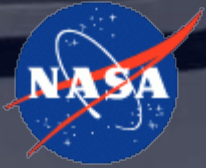

Summary

Conclusions:

1. ADS-B is adequate for moderate wake surfing benefits.
2. Accurate wind estimates are critical for wake prediction.
3. Sustained fuel savings are possible above 5% for wake surfing at extended trail distances.
4. There is significant ride quality degradation at higher fuel flow savings.
5. Automatic control is a necessity, including throttles.

Recommendations:

1. Develop and test robust wake estimation, performance optimization, and wake-crossing prevention algorithms.
2. Through modeling and flight research, improve understanding of the causes of ride quality degradation.
3. Characterize wake strength, descent, and decay downstream of the trail airplane.
4. Develop routing and scheduling algorithms for civil operators, and meta-aircraft operations for air traffic control.



Questions?

Examples of Wake Dynamics

B-767
A. Brown, AIAA 2007-289

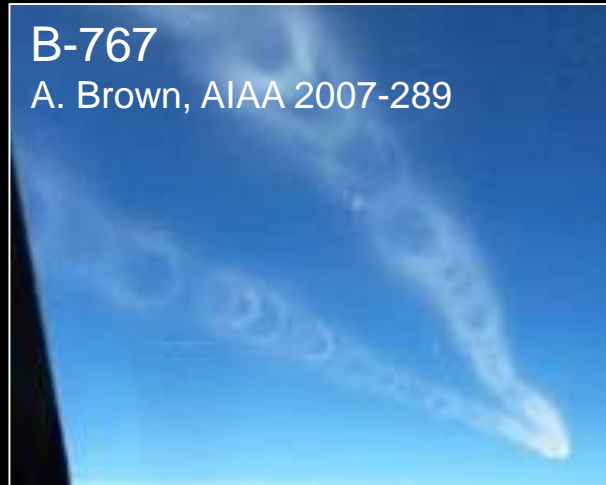

B-737 Contrail Vortex
© B. Whittaker

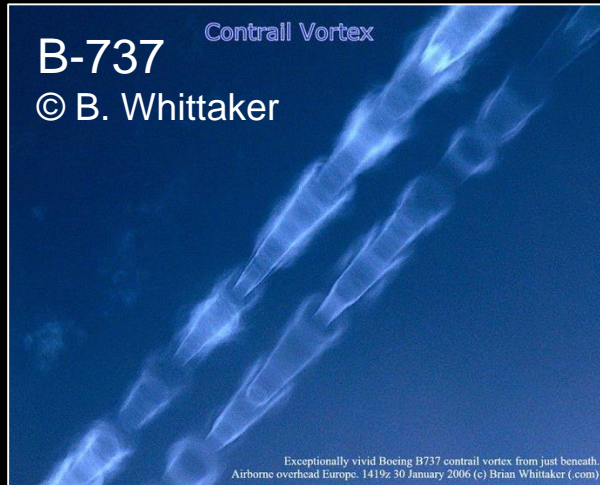

DC-8
NASA ACCESS Mission Video



B-757
NASA SUCCESS Mission Video





Relative Navigation and Wake Prediction

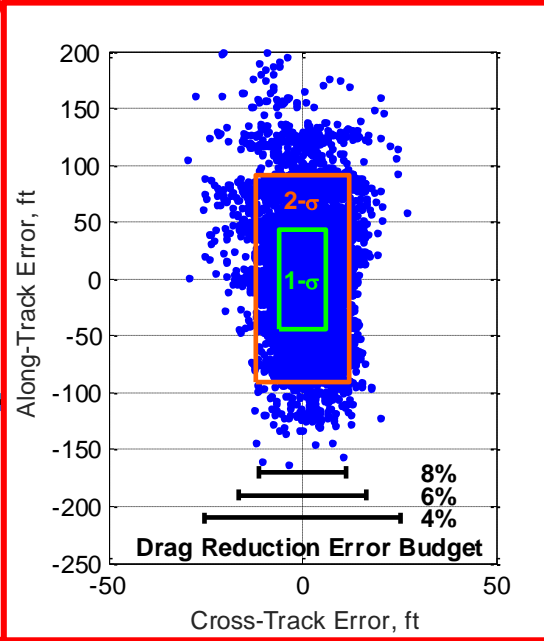
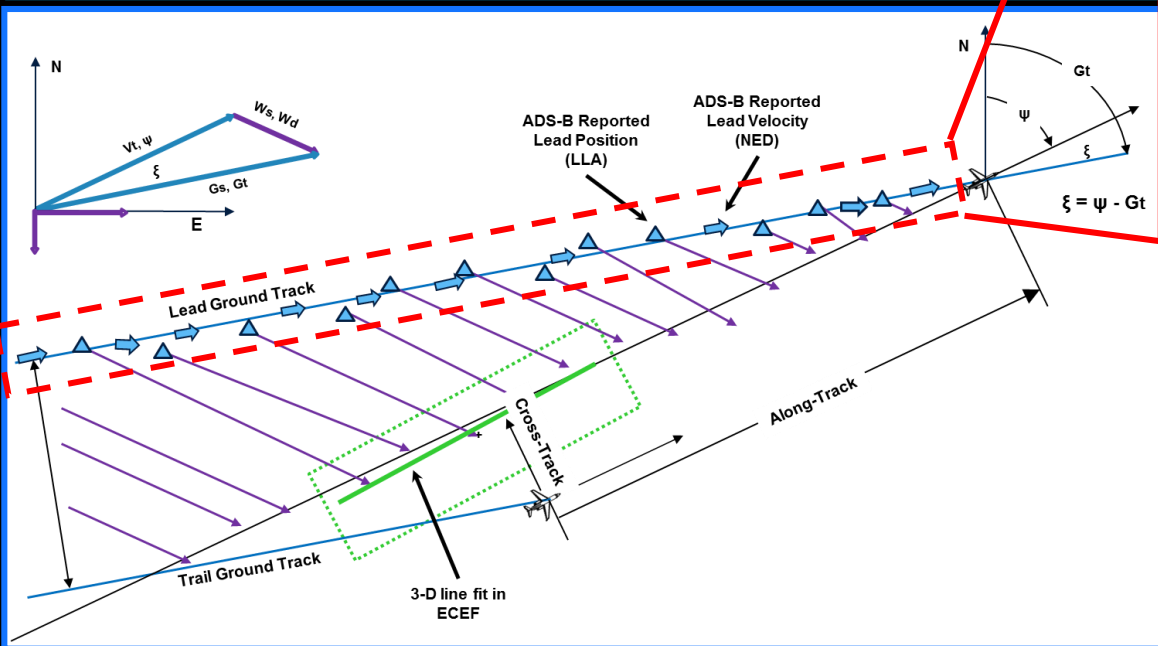
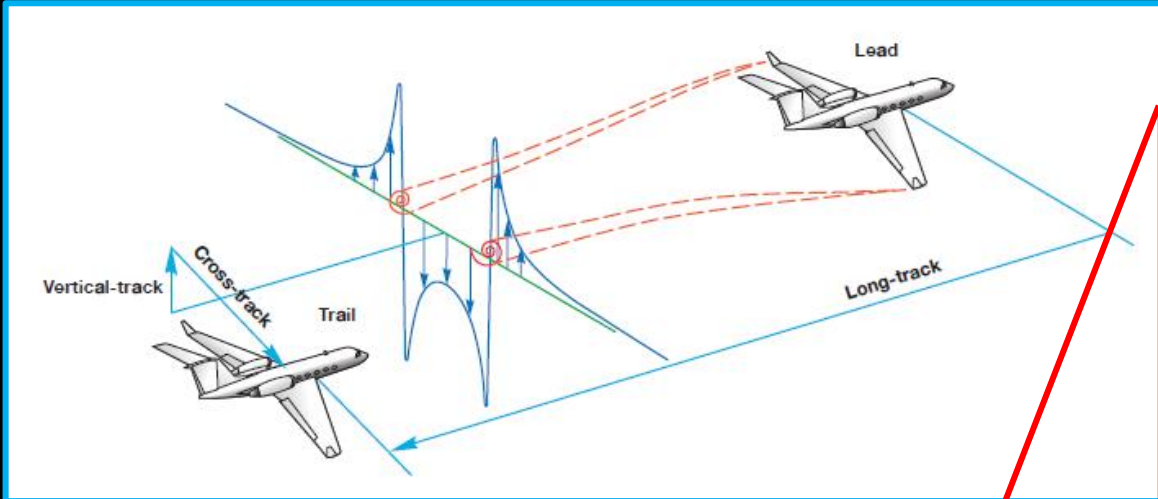

The trail airplane flies a wake-relative trajectory.

Wake prediction functions in the autopilot compute a wind-corrected trajectory for the trail airplane. This trajectory is relative to the lead airplane's wake.

Timing uncertainty in ADS-B messages results in larger errors in along-track vs. cross-track.

One knot of error in cross-track wind speed adds 10 ft of error to the predicted wake location.

Simplified Wake Location Prediction

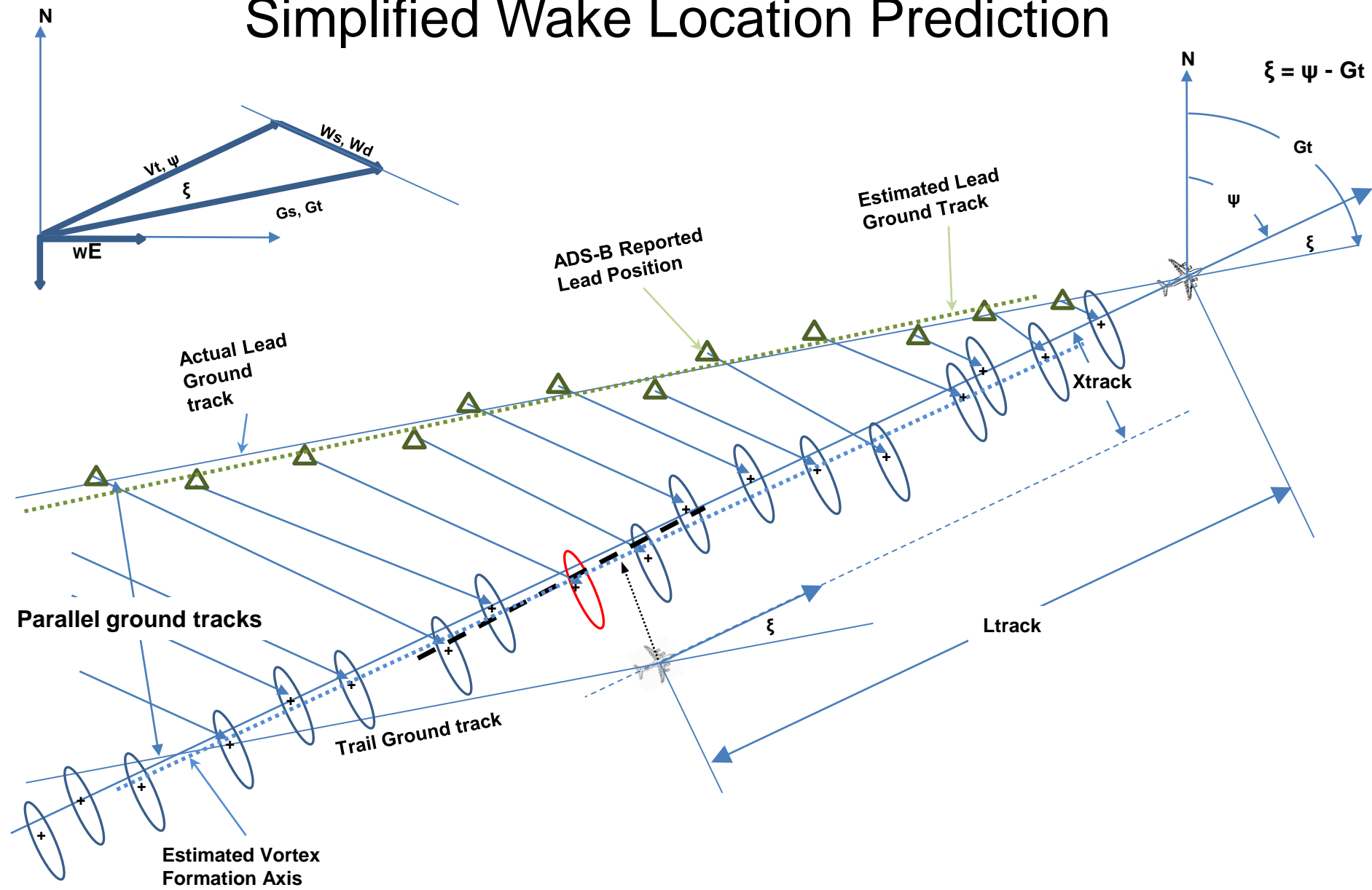



Pilot Throttle Cue and Wake Display



Despite good results in the piloted sim, the pilots initially found the throttle cues “Unsatisfactory” in flight.

For the final flight, the pilot along-track error cue was re-designed with an increased range of view, and a relaxed acceptable error criteria.

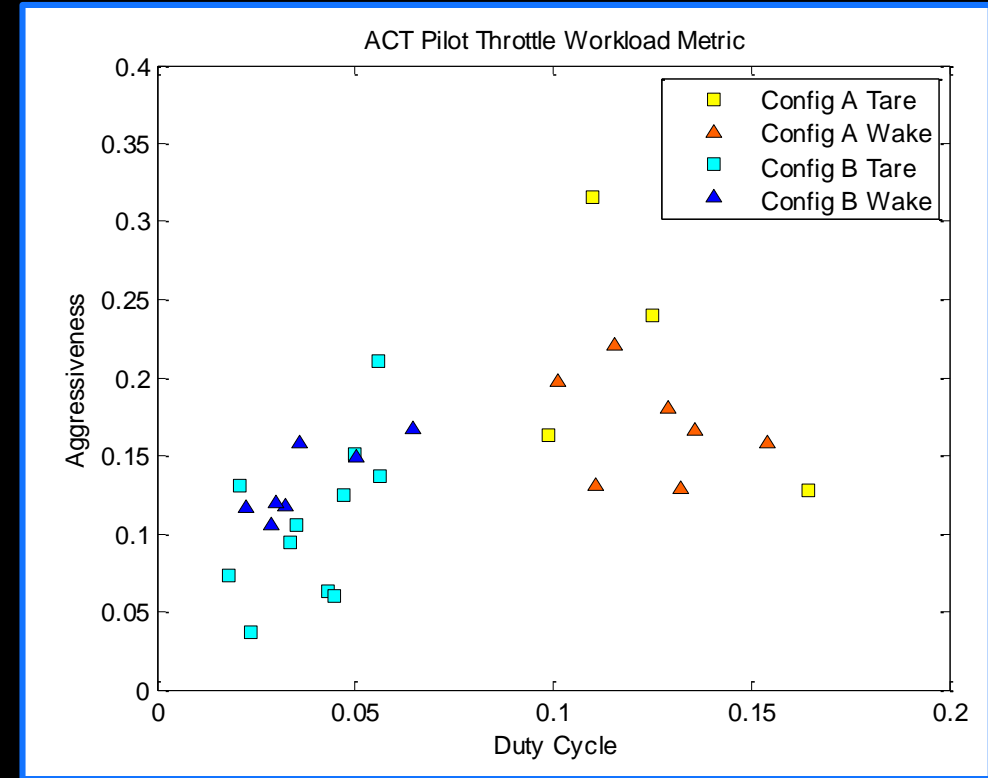

The modified display reduced the pilot workload to “Satisfactory” and improved post-flight calculation of fuel flow savings.