



INFLUENCE OF FIBER CONTENT, THERMAL CYCLES AND CREEP ON ELECTRICAL RESISTIVITY MEASUREMENTS OF SiCf/SiC MINICOMPOSITES

Amjad S. Almansour
Ceramic & Polymer Composites Branch
NASA Glenn Research Center
Cleveland, Ohio

Gregory N. Morscher
Mechanical Engineering Department
The University of Akron
Akron, Ohio



42nd International Conference and Expo on Advanced Ceramics and Composites
Daytona Beach, Florida, USA
January 21-26, 2018

Funded by:
Office of Naval Research (ONR) and NASA Transformational Tools and Technologies Project (TTT)

Outline

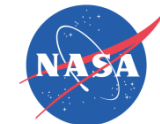

- Introduction.
- Materials and properties.
- Experimental methodology and set up.
- Electrical resistance (ER) sensitivity to damage at RT.
- ER during thermal cycles and high-temperature creep.
- ER temperature dependence in Hi-Nicalon STM minicomposites.
- Conclusions.

Introduction

SiC_f/SiC Ceramic Matrix Composites (CMCs) are currently being implemented in high-temperature applications such as the new generations of aircraft engines due to the *Improved* engine efficiency obtained by using high-temperature capable CMC components & *Reduced* component weight, cooling requirements, fuel consumption & emissions (NO_x and CO₂).

Electrical Resistivity has been shown to be very sensitive to damage in CMCs, and although, it is highly dependent on CMCs' damage state and temperature, this dependence is still not well understood. It is investigated here with the use of ceramic matrix minicomposites.

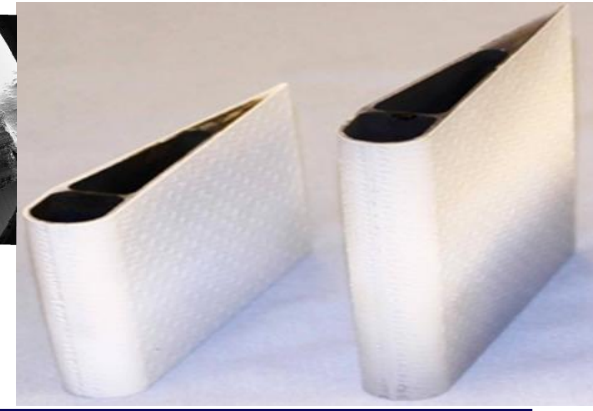
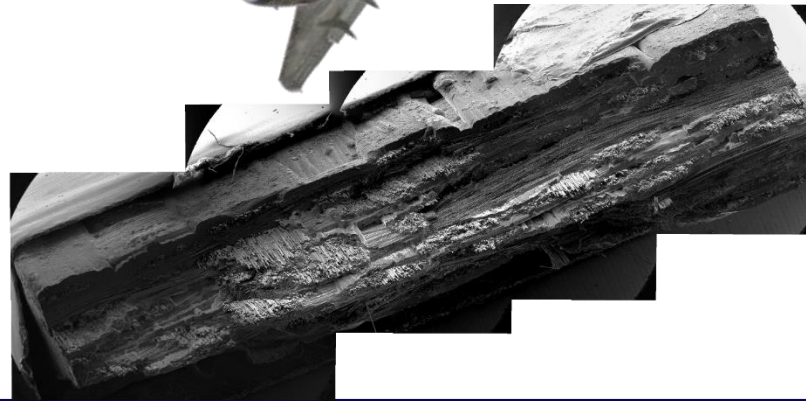
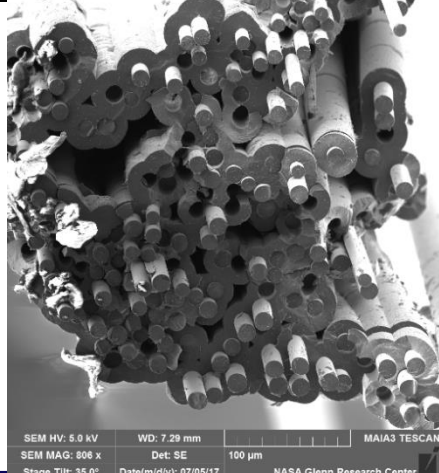
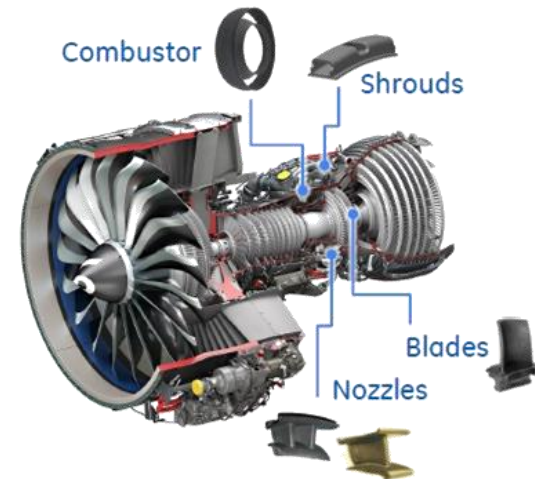
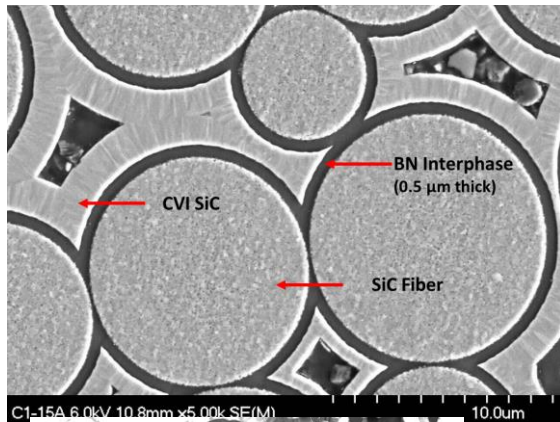

Materials and Properties

Single Fiber Tow Minicomposite Cross-sections

Hi NicalonTM
Fibers

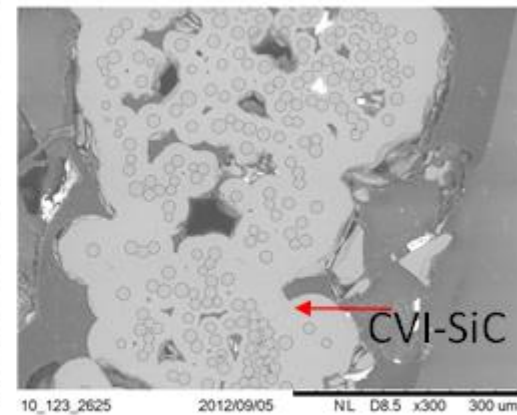
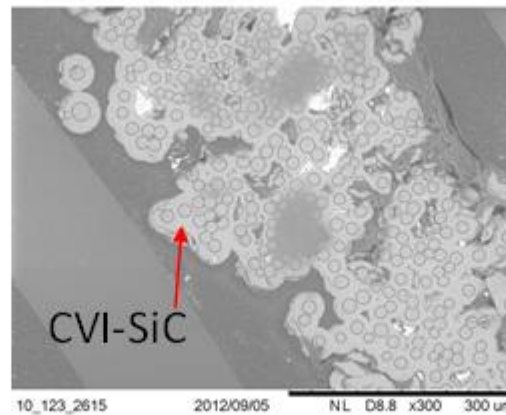
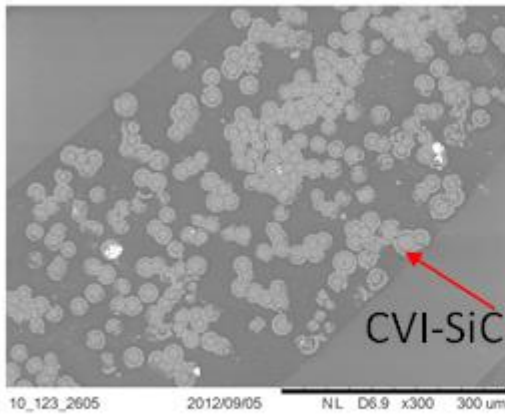

Fiber
Content:
16 to
43%

Decreasing fiber volume fraction

Hi Nicalon Type STM
Fibers

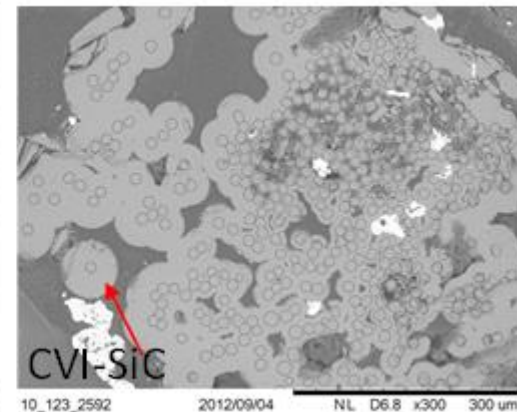
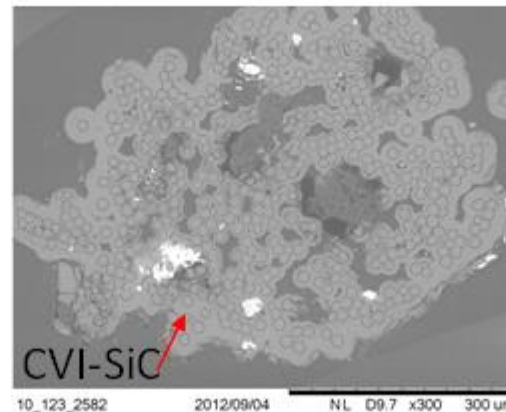
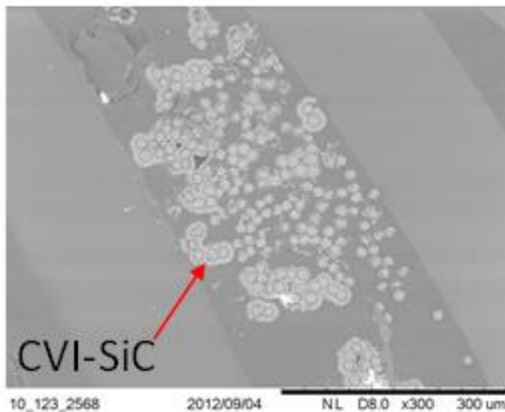

15 to
47%

- The volume and mass of the fiber tow were estimated based on the average fiber diameter, number of fibers per tow, specimen length and density.
- The volume and mass of the interphase were estimated considering BN thickness of 1 μm on each fiber using SEM.
- Then backed out the volume and mass of the matrix from ROM.

Experimental Setup

RT

HT

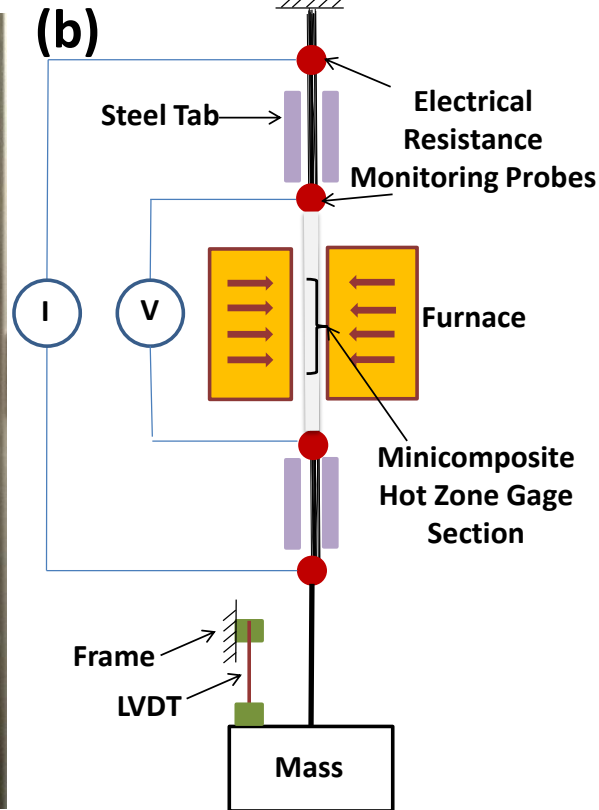
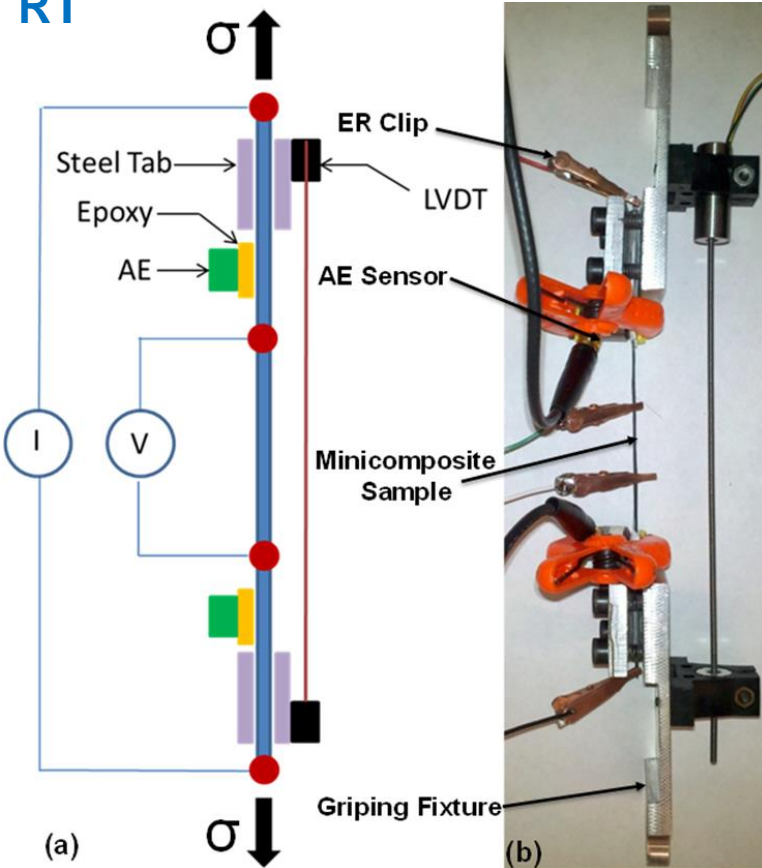

- Room temperature monotonic and cyclic tensile loading
 - Displacement control: 0.08-0.5 mm/min
 - Load cell: 500 N or 5000 N
- Modal Acoustic Emission monitoring
 - Digital Wave Fracture Wave Detector
 - AE sensors placed on epoxy tabs
 - Only AE events originating from gage section used for analysis

- Electrical Resistance monitoring
 - Four-probe method with Agilent multimeter
 - Inner probe spacing: RT 25.4 mm, HT 88 mm
- Elongation measurement
 - LVDT attached to specimen tabs

Electrical Resistivity Model For As-fabricated Minicomposites

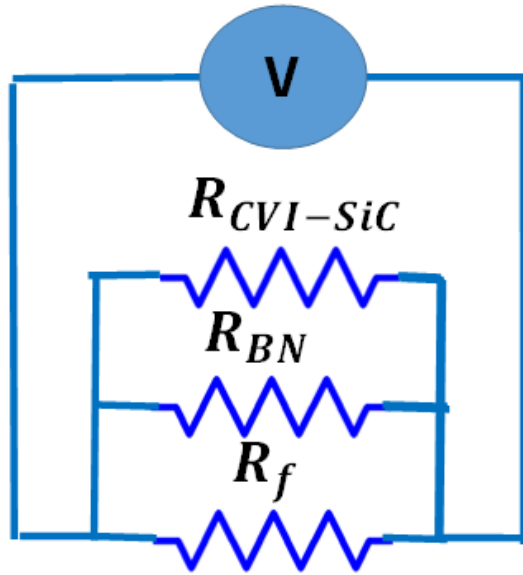

$$\rho = \frac{RA}{L} \sim \frac{1}{R^o} = \frac{1}{R_f^o} + \frac{1}{R_{BN}^o} + \frac{1}{R_{CVI SiC}^o}$$

$$\rho = \frac{V_f A_c}{\rho_f L} + \frac{V_{BN} A_c}{\rho_{BN} L} + \frac{V_{CVI SiC} A_c}{\rho_{CVI SiC} L}$$

$$\rho^o = \frac{\rho_f \rho_{BN} \rho_{CVI SiC}}{[(V_f \rho_{BN} \rho_{CVI SiC}) + (V_{CVI SiC} \rho_f \rho_{BN}) + (V_{BN} \rho_f \rho_{CVI SiC})]}$$

Determine the electrical resistivity of the gage length

Longitudinal view of as-fabricated (Uncracked) minicomposite

$$I_i = \frac{R_o}{L * A_c * \rho_i * V_i}$$

Determine % of current running in each constituent

Effect of Fiber Type and Content on Electrical Resistivity in As-fabricated Minicomposites at RT

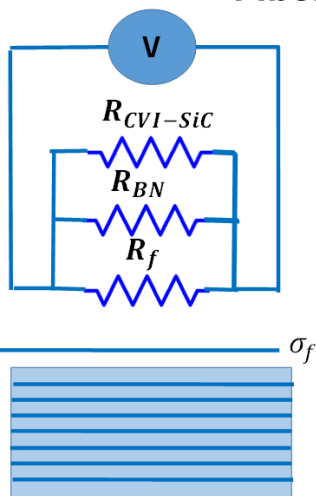
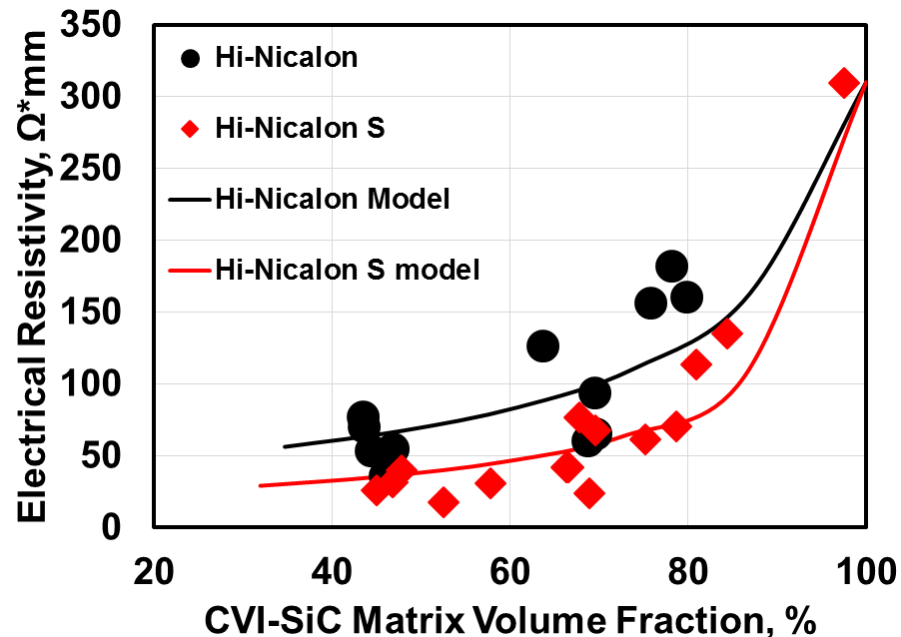
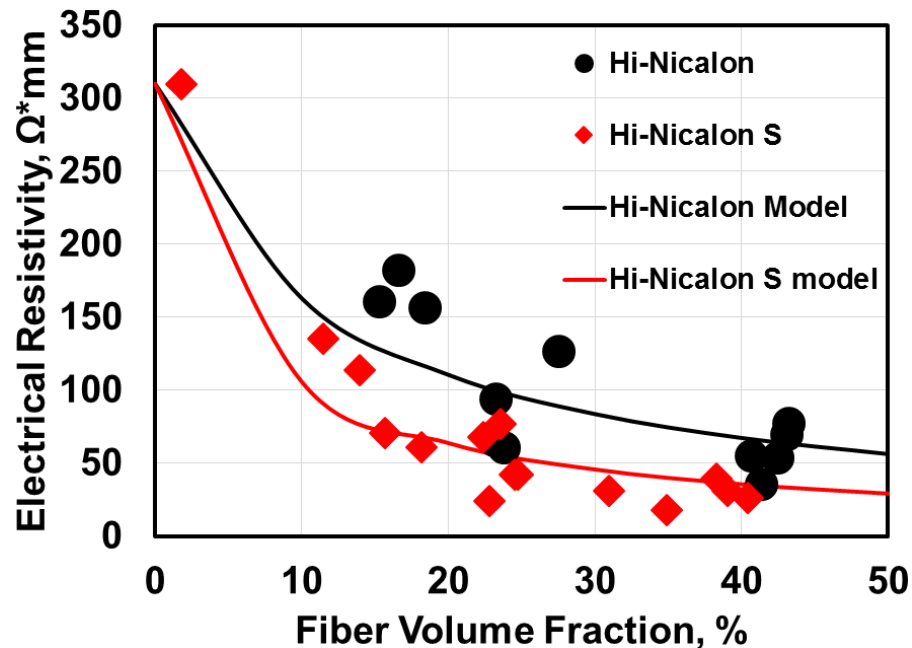

- RT Resistivity of the CVI-SiC matrix was assumed to be $310 \Omega^*mm$ which is the resistivity value for minicomposites with 97% CVI-SiC content
- RT Resistivities of the Hi-NicalonTM fibers, Hi-Nicalon STM fibers, C interphase and BN interphase were assumed to be 30, 15, 0.078 , $1 \cdot 10^{10} \Omega^*mm$ respectively.

Electrical Resistivity Model For Damaged Minicomposites

When CMCs are loaded above the matrix cracking stress:

- Fibers carry all of the applied load in the vicinity of through-thickness matrix crack.
- In the fiber/matrix debond region, load transfer and sharing is dictated by the interfacial shear stress.

Then two electrical current path extremes are modeled:

- 1) Electrical current is only carried by the fibers in crack opening displacement (u).
- 2) Electrical current is only carried by the fibers in crack opening displacement (u) and in debond region 2δ

➤ Matrix crack opening**,
$$u = \frac{\sigma^2 R_f}{4\tau f^2 E_f \left(1 + \frac{E_f f}{E_m(1-f)}\right)}$$

where R_f is the fiber radius, t is the interfacial shear stress, and E is the elastic modulus.

➤ Sliding or stress-transfer length**,
$$\delta = \frac{\alpha R_f (\sigma + \sigma_{res})}{2\tau}$$

where δ represents associated with the interfacial shear stress where α is $(1-f)E_m / fE_c$ and σ_{res} is the residual stress

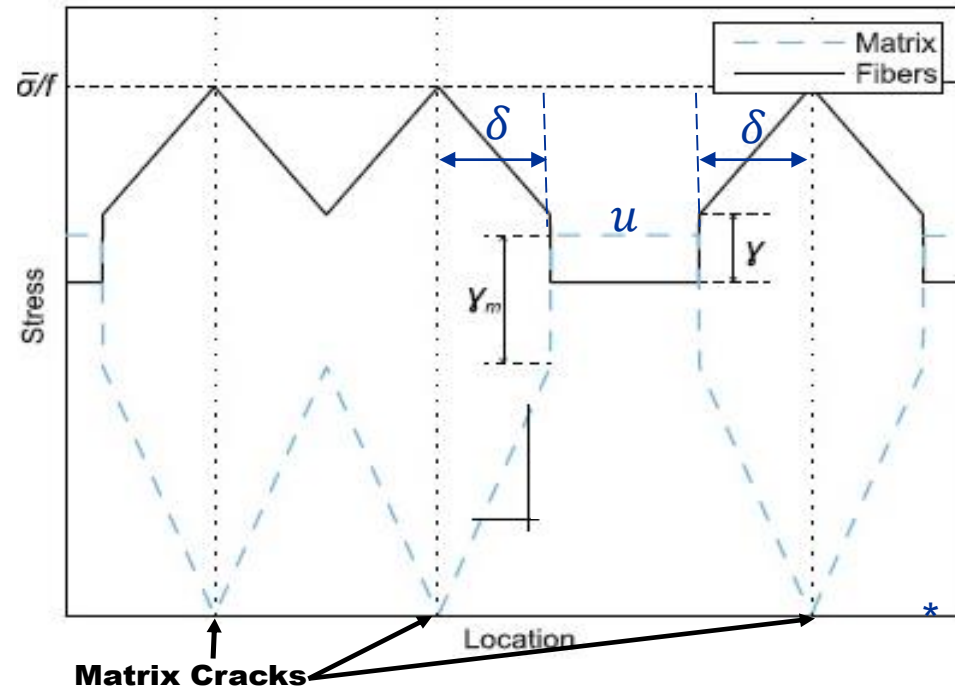

*Hutchinson, J. W., Jensen, H. M., Sep. 1990. Models of fiber debonding and pullout in brittle composites with friction. Mech. Mater. 9 (2), 139–163. 10.

**W.A. Curtin, B.K. Ahn, N. Takeda, Modeling brittle and tough stress–strain behavior in unidirectional ceramic matrix composites, Acta Mater. 46 (10) (1998) 3409–3420.



Modelling Matrix Cracking Formation Effect on ER

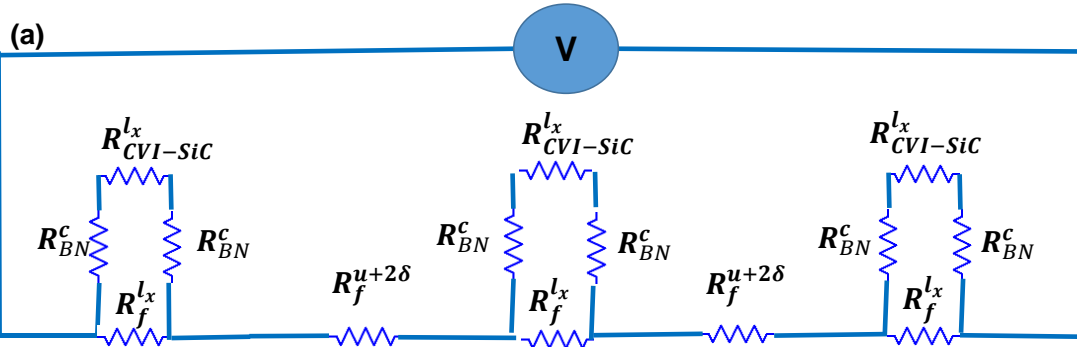

$$R = Nc \left(R_f^c + \left[\frac{V_f A_c}{\rho_f l_x} + \frac{1}{\frac{\rho_{CVI-SiC} l_x}{V_{CVI-SiC} A_c} + 2R_{BN}^c} \right]^{-1} \right)$$

$$R_f^c = \frac{\rho_f l_f^c}{V_f A_c}$$

R_{BN}^c was assumed to be approaching zero

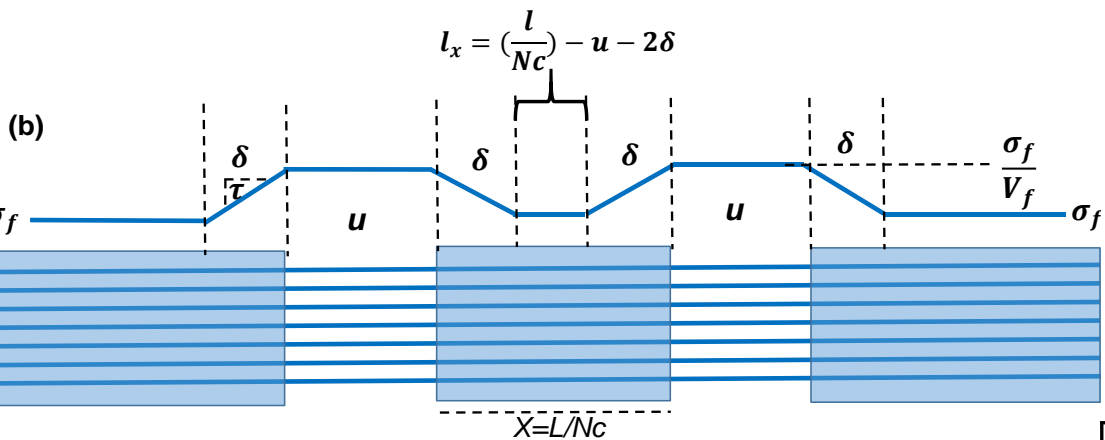

$$l_x = \frac{L}{Nc} - u, l_f^c = u$$

$$l_x = \frac{L}{Nc} - 2\delta - u, l_f^c = u + 2\delta$$

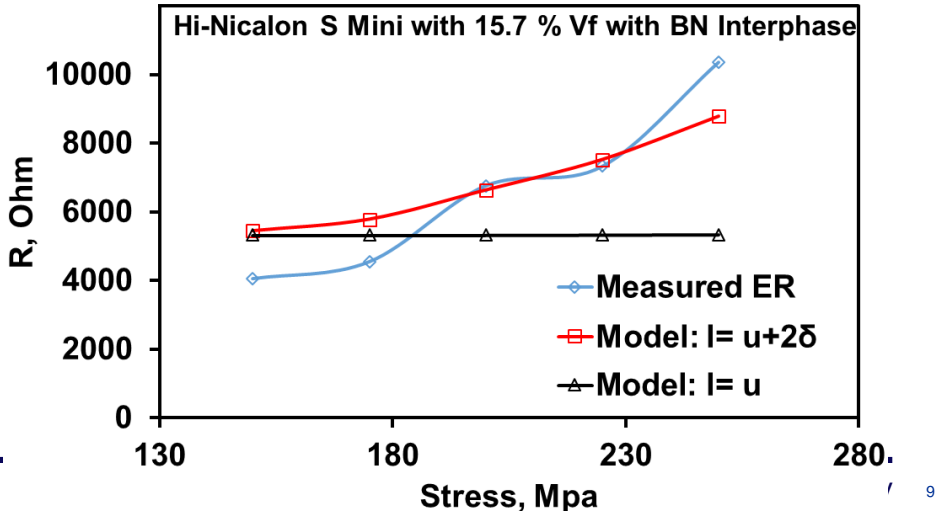
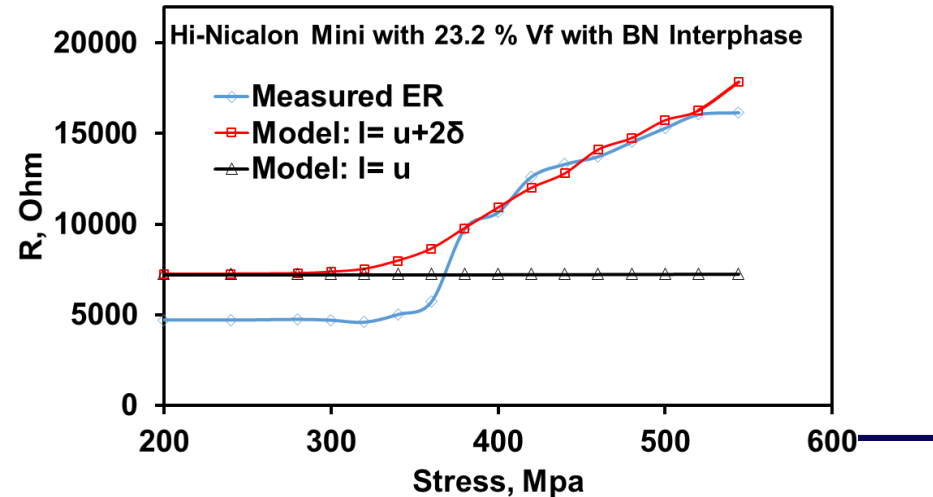



Modelling Matrix Cracking Formation Effect on ER

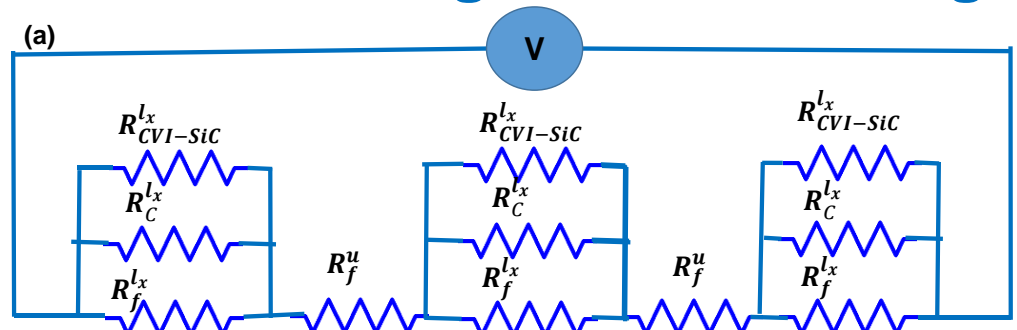

$$R = Nc \left(R_f^c + \left[\frac{V_f A_c}{\rho_f l_x} + \frac{V_C A_c}{\rho_C l_x} + \frac{V_{CVI\ SiC} A_c}{\rho_{CVI\ SiC} l_x} \right]^{-1} \right)$$

$$R_f^c = \frac{\rho_f l_f^c}{V_f A_c}$$

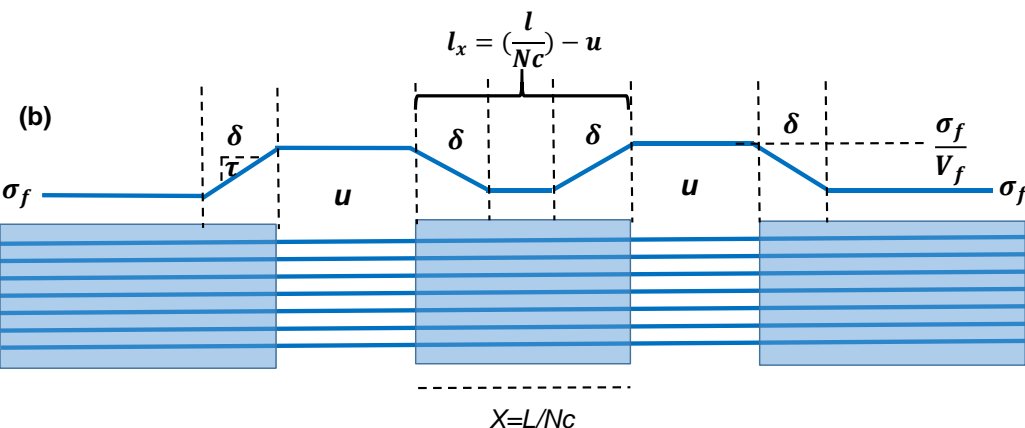

$$l_x = \frac{L}{Nc} - u, \quad l_f^c = u$$

$$l_x = \frac{L}{Nc} - 2\delta - u, \quad l_f^c = u + 2\delta$$

$$I_i = \frac{R_o}{L * A_c * \rho_i * V_i}$$

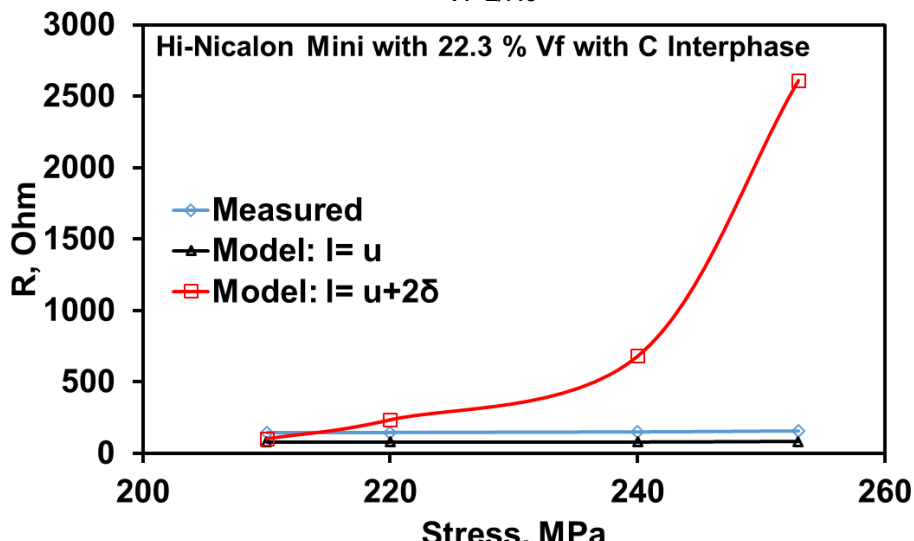

- Hi-Nicalon™ /BN minicomposite ~ 77.49% of current is carried by the fibers and 22.5 % by the matrix
- Hi-Nicalon S™ /BN minicomposite ~ 80.49% of current is carried by the fibers and 19.4 % by the matrix
- Hi-Nicalon™ /C minicomposite ~ 0.83% of current is carried by the fibers and 0.25 % by the matrix and 98.9 % by the C interphase.



Influence of Hysteresis Loading on ER of SiC/SiC Macrocomposite and Minicomposite

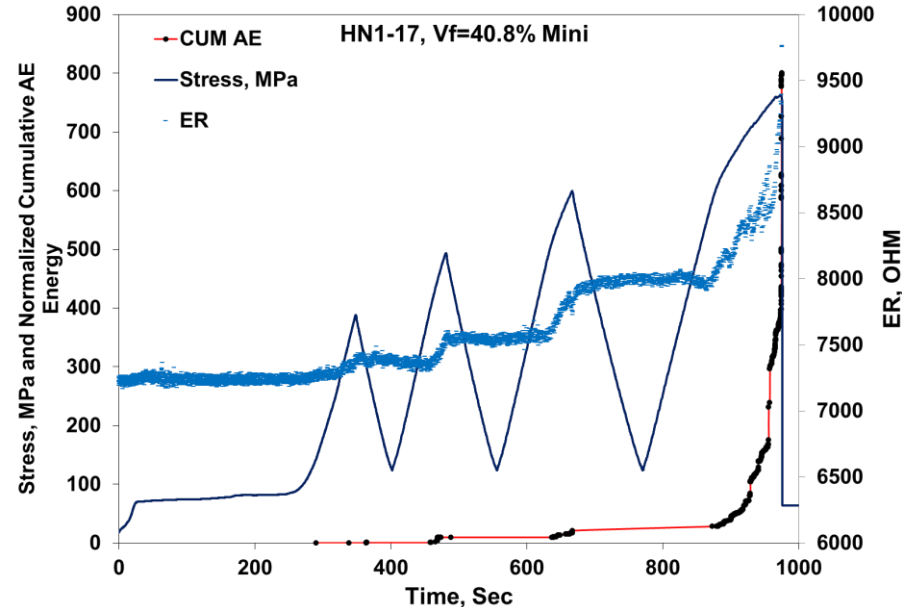
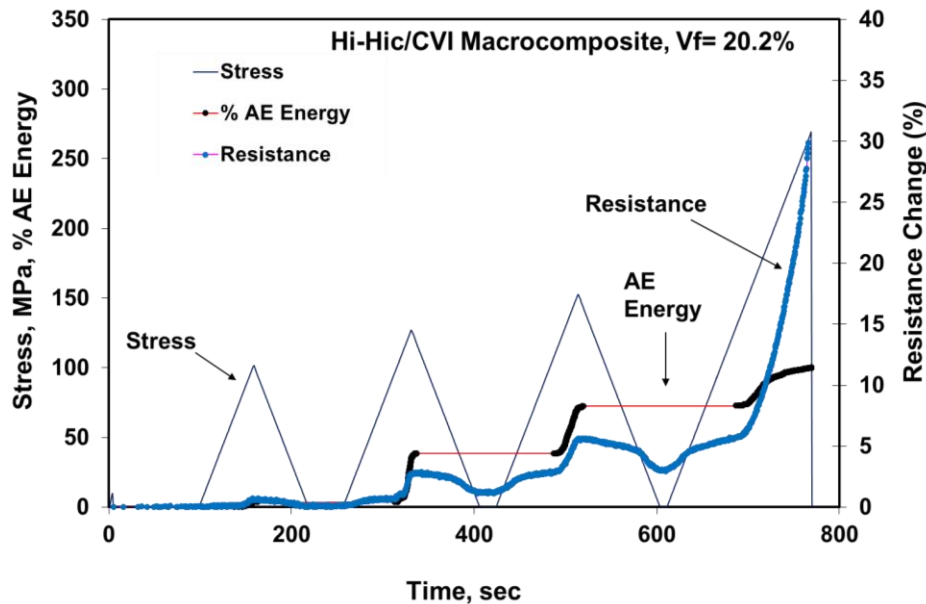

- Electrical resistance in Hi-Nicalon™ macrocomposites* changed during cyclic tensile loading, where it started increasing with the increase in stress above the onset of matrix cracking stress. Next, it continued to increase with the increase in maximum stress applied. Upon unloading, the resistance decreased and reached its lowest value in the loop.
- Unloading and reloading in minicomposites has a different effect on the electrical resistance compared with the hysteresis loops' effect on ER in a macrocomposite which is due to the complex fiber architecture in macrocomposites where outer tows apply pressure on the inner tows which increases the wear during unload reload cycles.

*Smith, C., Morscher, G., & Xia, Z. (2008). Monitoring damage accumulation in ceramic matrix composites using electrical resistivity. *Scripta Materialia*, 59(4), 463–466. doi:10.1016/j.scriptamat.2008.04.033



Effect of High Temperature Cycles on CVI-SiC Matrix

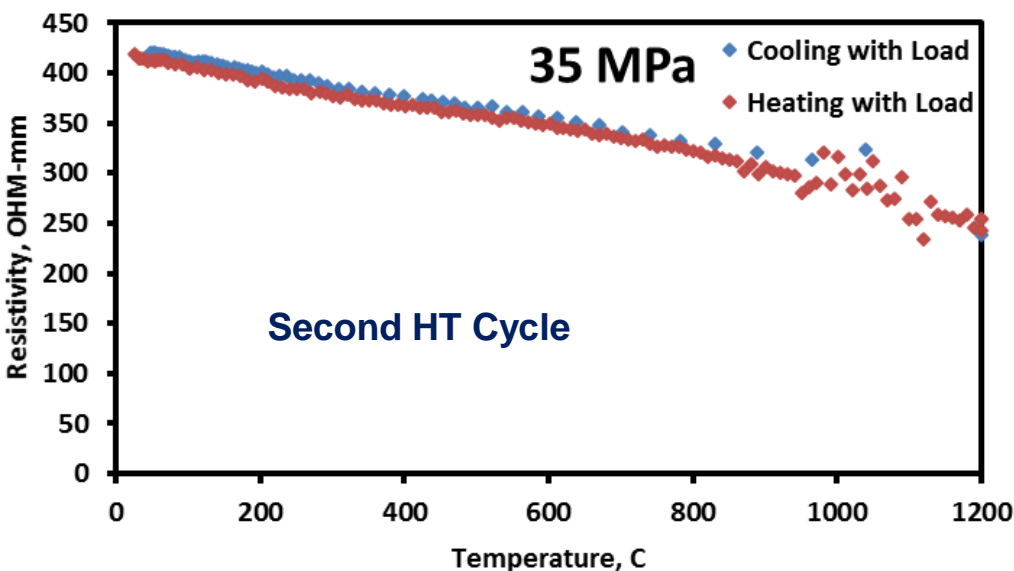
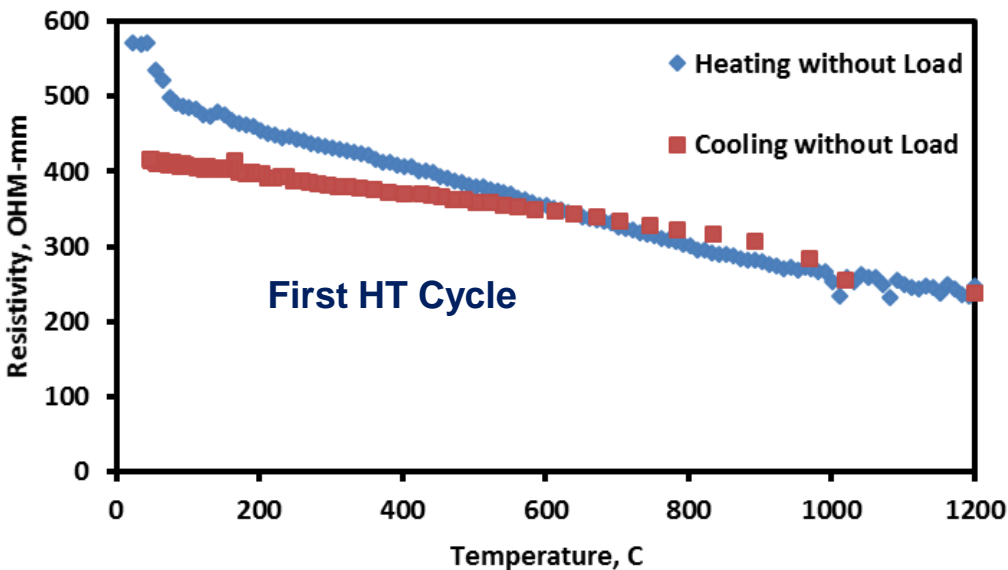

- In order for an electron to jump from a valence band to a conduction band, it requires a specific minimum amount of energy for the transition.
- Band gap refers to the energy difference between the top of the valence band and the bottom of the conduction band.
- As the temperature increased the available thermal energy increased. That decreased the band gap which increased the minicomposite conductivity and decreased the minicomposite electrical resistivity.
- It should be noted that electrical resistivity wasn't fully recovered after the first thermal cycle because CVI-SiC matrix was heat-treated during the thermal cycle and this sample may be processed at a temperature lower than 1200 °C.
- This behavior indicates that electrical resistance health monitoring technique is sensitive to changes that occur in CMC due to thermal cycles and heat treatments with or without mechanical loading.



Effect of Fiber Content and Matrix Cracks on ER Temperature Dependence

- Plateau in ER of precracked minis above 570 °C may be caused by the oxidation of the BN interphases and Hi-Nicalon S™ fibers in the vicinity of CVI-SiC matrix cracks in the precracked minicomposites contributed to an increase in precracked minicomposites' electrical resistivity.
- The increase in Hi-Nicalon S™ fibers volume fractions (decrease in CVI-SiC volume fractions) in the precracked minicomposites effectively decreased the resistivity of the material since Hi-Nicalon S™ fibers are more conductive than CVI-SiC matrix.

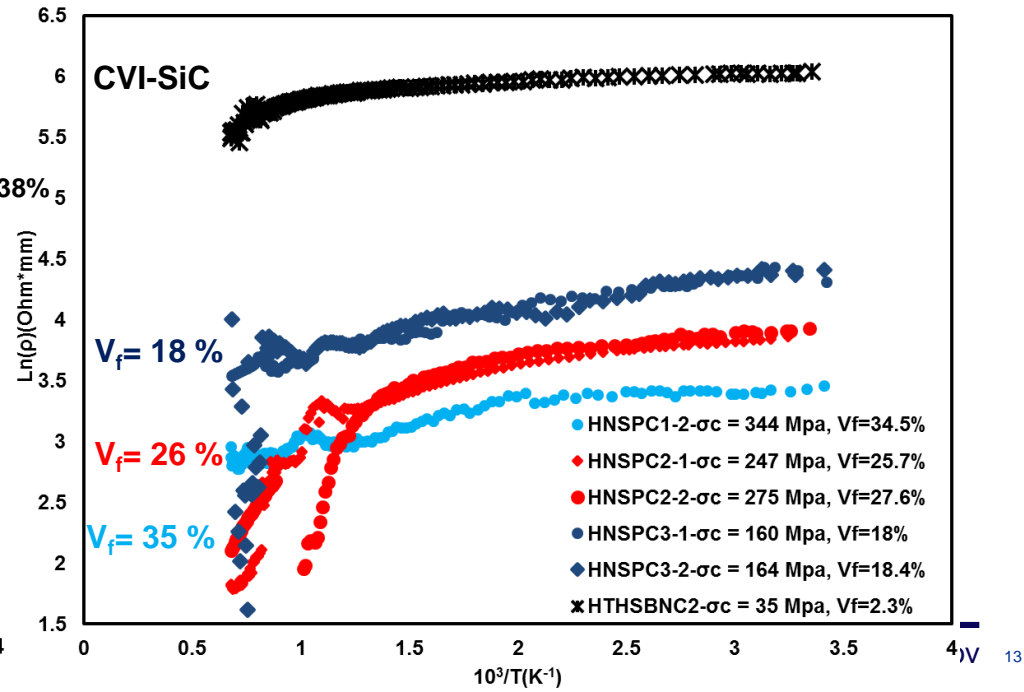
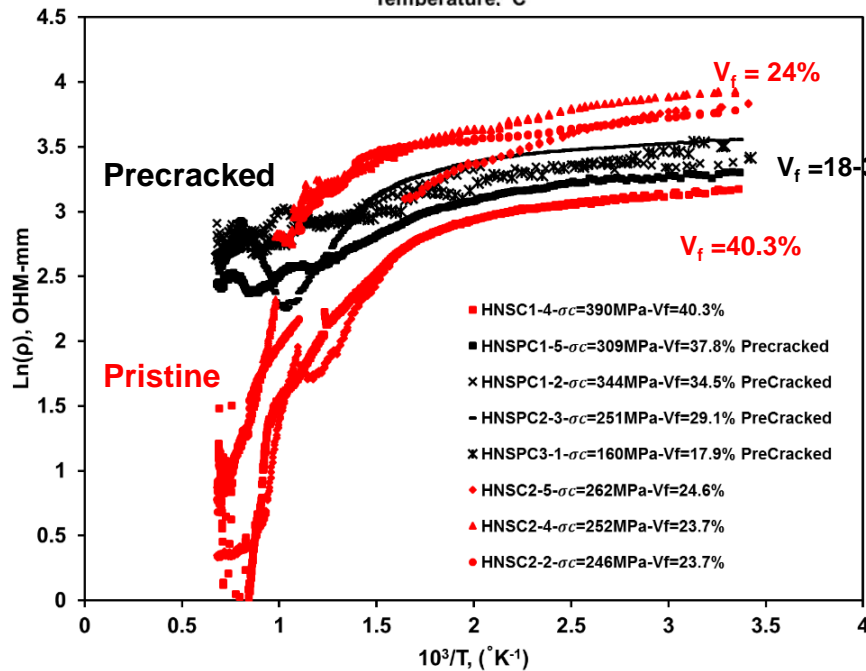
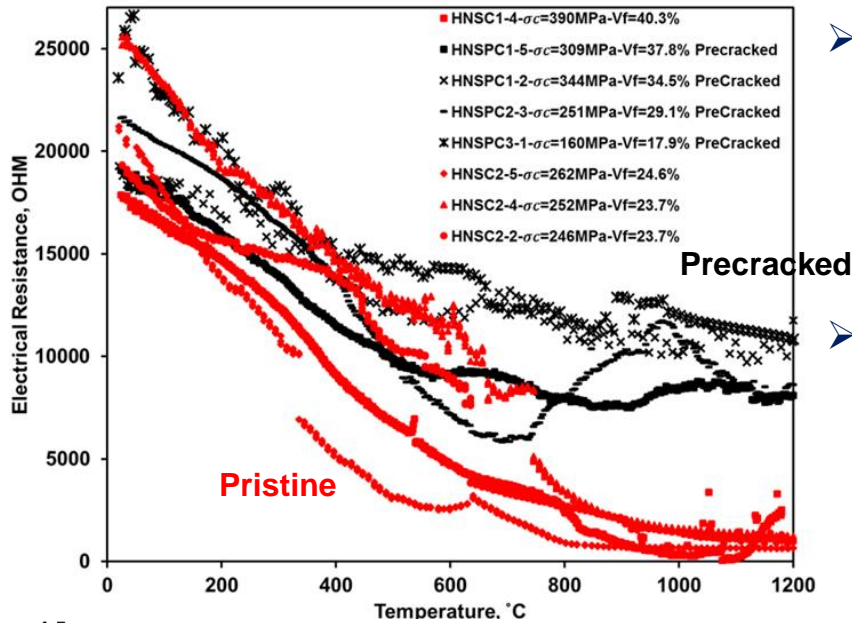



Effect of Matrix Cracks on ER in Creep

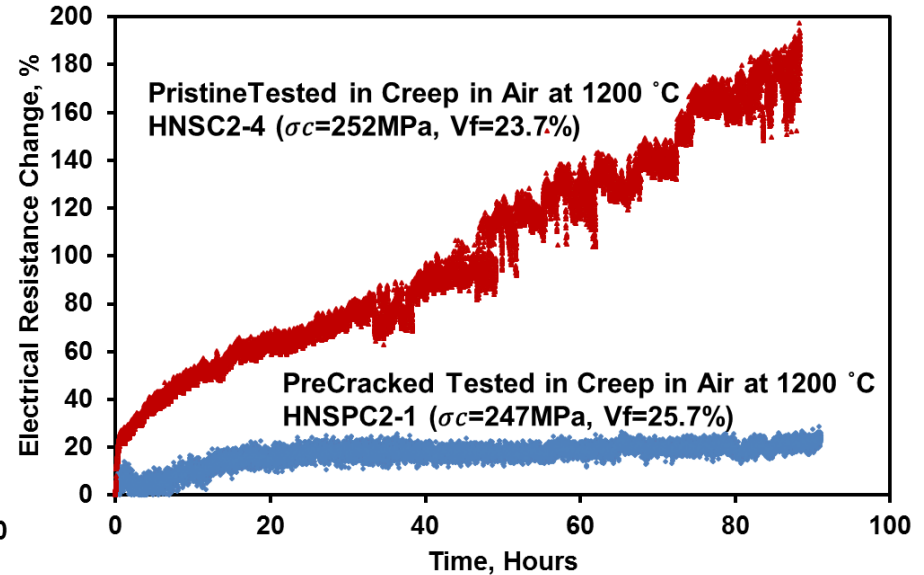
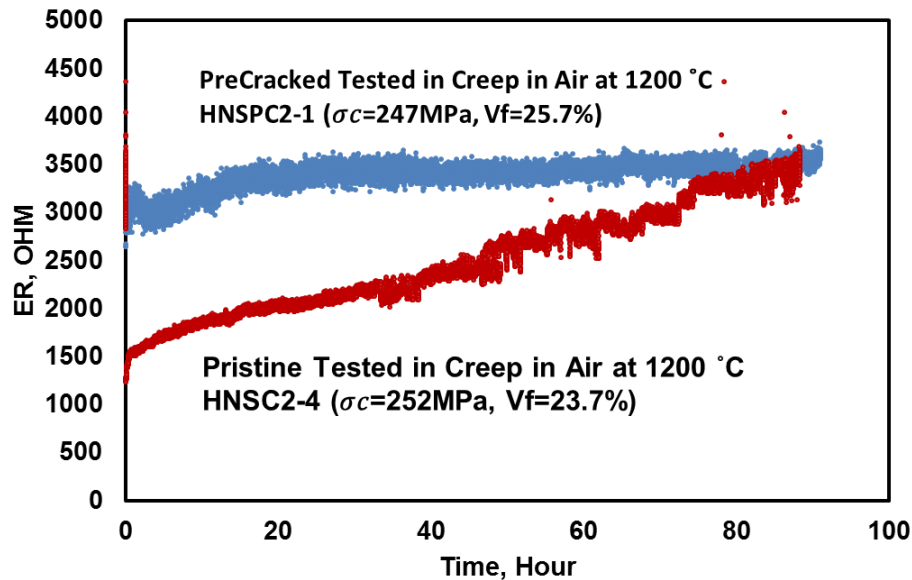

ER percent change in precracked minicomposite in creep is smaller than that of as-fabricated minicomposite. In pristine minicomposites, a parallel circuit with no cracks is assumed for electrical current. The current will prefer more conductive constituent so these seem to be the possible scenarios:

- Matrix crack formation.
- Increase in fiber and/or matrix resistivity due to elongation. Not too much.
- Decoupling of fiber and matrix – It's possible for fibers to contract due to poisson's effect due to stress increase and matrix to pull away from fibers which would push current to fibers.
- Fiber breakage during the test which would push current to matrix.
- The high matrix relaxation in pristine samples and rapid load shedding from CVI-SiC matrix to Hi-Nicalon S fibers during primary creep stage. This scenario is possible depending on the piezoresistivity* of the fibers where some materials have increase in resistivity with stress.

*Akira Kishimoto, Ginjiro Toyoguchi and Hiroshi Ichikawa "Piezoresistivity of Hi-Nicalon Type-S Silicon Carbide-Based Fiber"



Effect of Matrix Cracks on ER in Creep

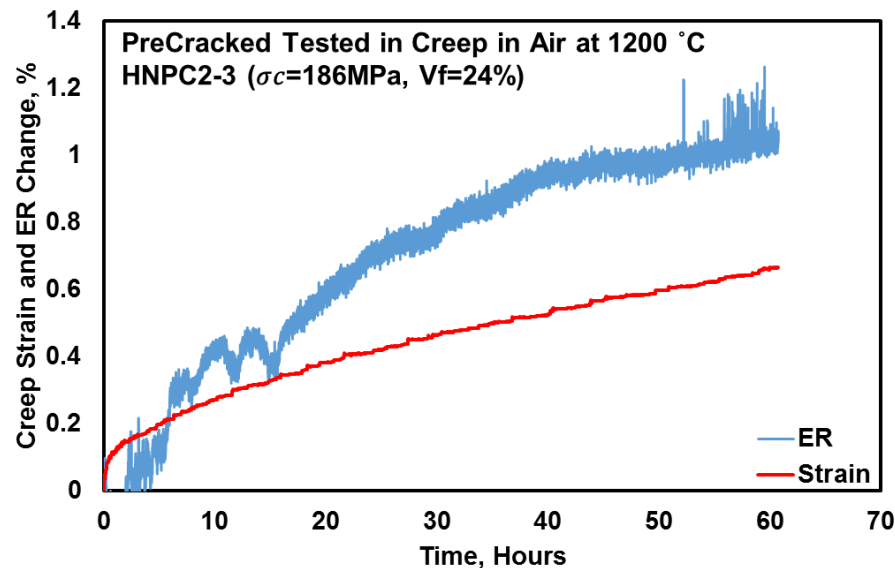
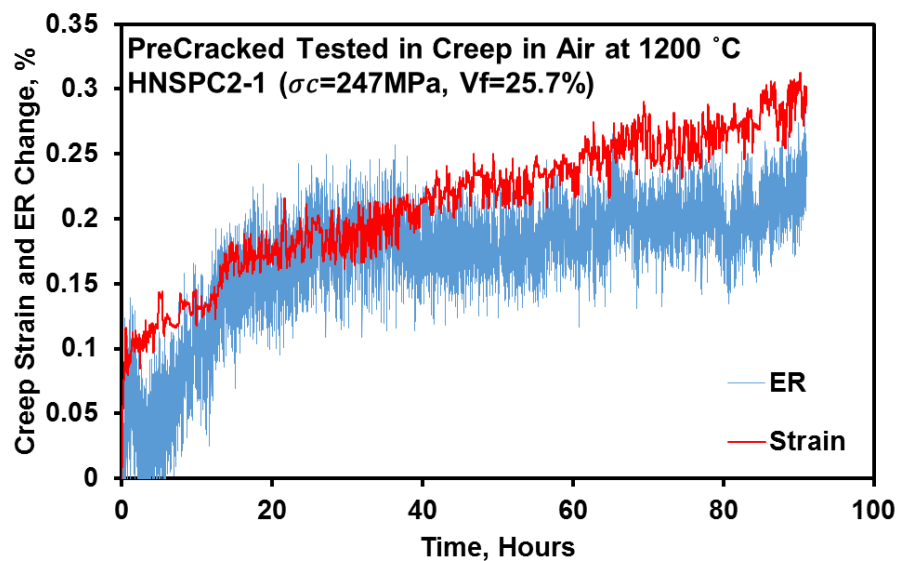

- Both curves show a rapidly increasing primary region over the same time interval, followed by a quasi-steady-state increase to rupture.
- The increase in ER maybe due to the increased length and “decreased” cross-sectional area due to creep.



Conclusions

- The influence of fiber content, type, interphase, heat treatment cycles and creep on electrical resistivity measurements of SiC_f/SiC minicomposites was studied.
- Derived ER model for minicomposites with different fiber type, fiber content and interphase type in monotonic tensile tension at RT.
- ER response during unload/reload loops in minicomposites is different than that in macrocomposites due to the more wear and sliding that occurs in macrocomposites and other aspects such as non-through-thickness transverse cracking, interlaminar cracking and maybe larger scale fiber breakage, which are not pertinent to single tow minicomposites.
- ER is temperature dependent and has shown sensitivity to oxidation at intermediate temperatures in precracked samples.

